

## **Traffic Study Appendices**

An electronic version of these documents that are compliant with Section 508 of the Rehabilitation Act of 1973 can be provided upon request to Chad Broussard, Environmental Protection Specialist, Bureau of Indian Affairs, Pacific Region, at (916) 978-6165 or by email at [chad.broussard@bia.gov](mailto:chad.broussard@bia.gov).

Appendix A – Existing Turning Movement Counts

---

---

## Old Redwood Hwy Shiloh Rd



Date: 07/28/2022  
Count Period: 7:00 AM to 9:00 AM  
Peak Hour: 7:30 AM to 8:30 AM

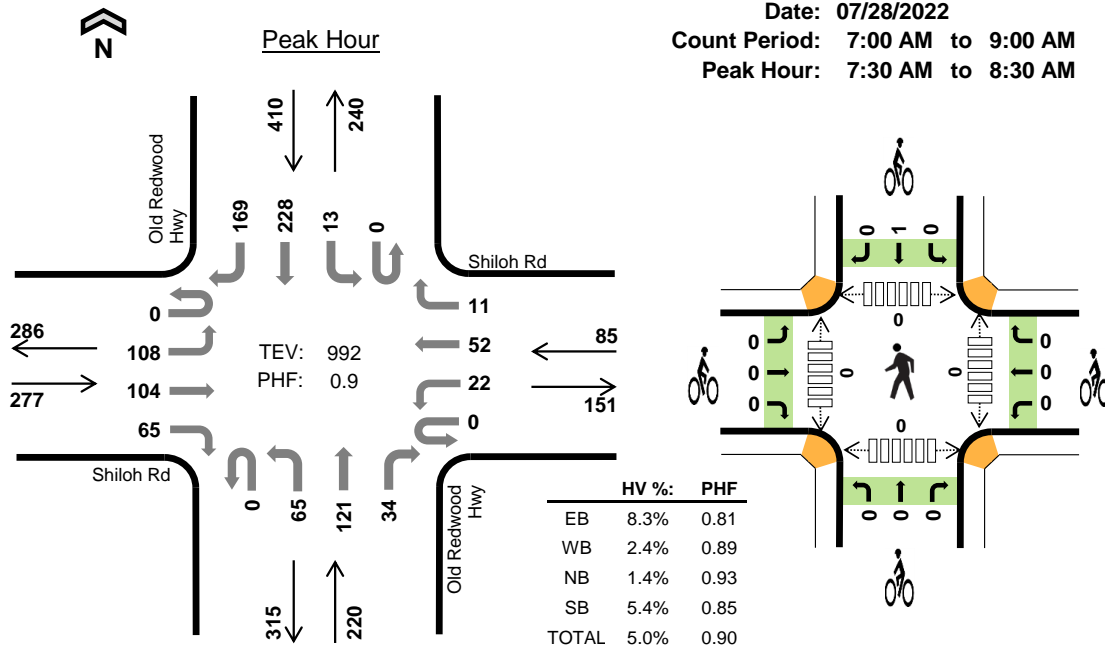

### Two-Hour Count Summaries

Interval Start	Shiloh Rd Eastbound				Shiloh Rd Westbound				Old Redwood Hwy Northbound				Old Redwood Hwy Southbound				15-min Total	Rolling One Hour	
	UT	LT	TH	RT	UT	LT	TH	RT	UT	LT	TH	RT	UT	LT	TH	RT			
7:00 AM	0	12	21	14	0	4	7	1	0	20	16	5	0	1	38	33	172	0	
7:15 AM	0	22	26	12	0	3	12	3	0	20	13	2	0	7	51	37	208	0	
7:30 AM	0	30	23	12	0	6	9	2	0	17	27	12	0	1	53	38	230	0	
7:45 AM	0	25	32	15	0	9	10	5	0	16	35	8	0	4	67	50	276	886	
8:00 AM	0	32	31	23	0	3	16	2	0	19	28	4	0	5	62	40	265	979	
8:15 AM	0	21	18	15	0	4	17	2	0	13	31	10	0	3	46	41	221	992	
8:30 AM	0	18	26	22	0	4	8	2	0	28	24	6	0	3	44	37	222	984	
8:45 AM	0	24	23	17	0	10	17	3	0	28	34	6	0	6	47	38	253	961	
Count Total	0	184	200	130	0	43	96	20	0	161	208	53	0	30	408	314	1,847	0	
Peak Hour	All	0	108	104	65	0	22	52	11	0	65	121	34	0	13	228	169	992	0
	HV	0	18	4	1	0	1	1	0	0	2	1	0	0	0	2	20	50	0
	HV%	-	17%	4%	2%	-	5%	2%	0%	-	3%	1%	0%	-	0%	1%	12%	5%	0

Note: Two-hour count summary volumes include heavy vehicles but exclude bicycles in overall count.

Interval Start	Heavy Vehicle Totals					Bicycles					Pedestrians (Crossing Leg)				
	EB	WB	NB	SB	Total	EB	WB	NB	SB	Total	East	West	North	South	Total
7:00 AM	4	0	1	5	10	0	0	1	0	1	0	0	0	0	0
7:15 AM	9	0	1	4	14	0	0	1	0	1	0	0	0	0	0
7:30 AM	7	0	2	6	15	0	0	0	0	0	0	0	0	0	0
7:45 AM	8	1	0	6	15	0	0	0	1	1	0	0	0	0	0
8:00 AM	3	1	1	4	9	0	0	0	0	0	0	0	0	0	0
8:15 AM	5	0	0	6	11	0	0	0	0	0	0	0	0	0	0
8:30 AM	6	1	2	6	15	0	1	1	1	3	0	0	0	0	0
8:45 AM	5	0	2	4	11	0	1	0	0	1	0	0	0	0	0
Count Total	47	3	9	41	100	0	2	3	2	7	0	0	0	0	0
Peak Hour	23	2	3	22	50	0	0	0	1	1	0	0	0	0	0

<b>Two-Hour Count Summaries - Heavy Vehicles</b>																		
Interval Start	Shiloh Rd				Shiloh Rd				Old Redwood Hwy				Old Redwood Hwy				15-min Total	Rolling One Hour
	Eastbound				Westbound				Northbound				Southbound					
	UT	LT	TH	RT	UT	LT	TH	RT	UT	LT	TH	RT	UT	LT	TH	RT		
7:00 AM	0	3	0	1	0	0	0	0	0	0	0	1	0	0	0	5	10	0
7:15 AM	0	9	0	0	0	0	0	0	0	0	1	0	0	0	0	4	14	0
7:30 AM	0	5	2	0	0	0	0	0	0	2	0	0	0	0	0	6	15	0
7:45 AM	0	6	1	1	0	0	1	0	0	0	0	0	0	0	0	6	15	54
8:00 AM	0	3	0	0	0	1	0	0	0	0	1	0	0	0	0	4	9	53
8:15 AM	0	4	1	0	0	0	0	0	0	0	0	0	0	0	2	4	11	50
8:30 AM	0	4	1	1	0	0	0	1	0	0	1	1	0	1	1	4	15	50
8:45 AM	0	3	2	0	0	0	0	0	0	0	1	1	0	0	2	2	11	46
Count Total	0	37	7	3	0	1	1	1	0	3	3	3	0	1	5	35	100	0
Peak Hour	0	18	4	1	0	1	1	0	0	2	1	0	0	0	2	20	50	0

<b>Two-Hour Count Summaries - Bikes</b>																	
Interval Start	Shiloh Rd			Shiloh Rd			Old Redwood Hwy			Old Redwood Hwy			15-min Total	Rolling One Hour			
	Eastbound			Westbound			Northbound			Southbound							
	LT	TH	RT	LT	TH	RT	LT	TH	RT	LT	TH	RT					
7:00 AM	0	0	0	0	0	0	0	0	1	0	0	0	0	0	0	1	0
7:15 AM	0	0	0	0	0	0	0	0	0	0	1	0	0	0	0	1	0
7:30 AM	0	0	0	0	0	0	0	0	0	0	0	0	0	0	0	0	0
7:45 AM	0	0	0	0	0	0	0	0	0	0	0	0	0	1	0	1	3
8:00 AM	0	0	0	0	0	0	0	0	0	0	0	0	0	0	0	0	2
8:15 AM	0	0	0	0	0	0	0	0	0	0	0	0	0	0	0	0	1
8:30 AM	0	0	0	0	0	0	1	0	1	0	0	1	0	0	0	3	4
8:45 AM	0	0	0	0	0	0	1	0	0	0	0	0	0	0	0	1	4
Count Total	0	0	0	0	0	0	2	0	2	1	0	2	0	0	0	7	0
Peak Hour	0	0	0	0	0	0	0	0	0	0	0	1	0	0	0	1	0

Note: U-Turn volumes for bikes are included in Left-Turn, if any.

### Hembree Ln Shiloh Rd

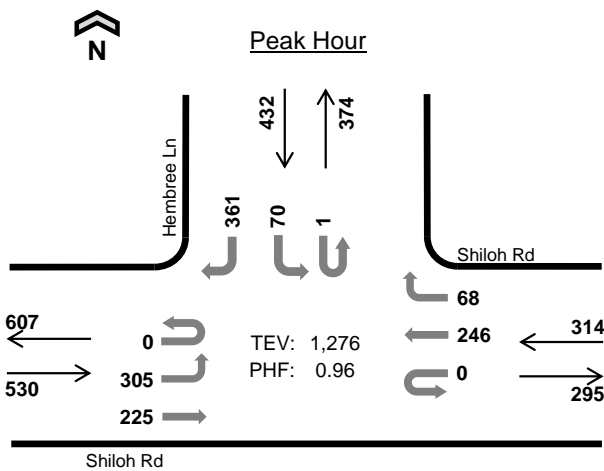

Date: 07/28/2022  
Count Period: 7:00 AM to 9:00 AM  
Peak Hour: 7:45 AM to 8:45 AM

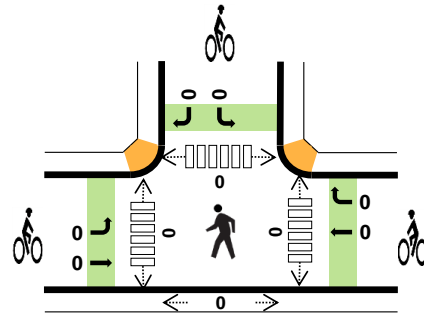

	HV %:	PHF
EB	7.2%	0.88
WB	6.7%	0.97
NB	-	-
SB	4.9%	0.94
TOTAL	6.3%	0.96

#### Two-Hour Count Summaries

Interval Start	Shiloh Rd Eastbound				Shiloh Rd Westbound				n/a Northbound				Hembree Ln Southbound				15-min Total	Rolling One Hour	
	UT	LT	TH	RT	UT	LT	TH	RT	UT	LT	TH	RT	UT	LT	TH	RT			
7:00 AM	0	43	40	0	0	0	52	14	0	0	0	0	0	9	0	55	213	0	
7:15 AM	0	46	67	0	0	0	55	14	0	0	0	0	1	6	0	69	258	0	
7:30 AM	0	79	57	0	0	0	47	17	0	0	0	0	0	10	0	77	287	0	
<b>7:45 AM</b>	<b>0</b>	<b>87</b>	<b>63</b>	<b>0</b>	<b>0</b>	<b>0</b>	<b>65</b>	<b>16</b>	<b>0</b>	<b>0</b>	<b>0</b>	<b>0</b>	<b>0</b>	<b>14</b>	<b>0</b>	<b>86</b>	<b>331</b>	1,089	
8:00 AM	0	68	66	0	0	0	65	16	0	0	0	0	1	22	0	92	330	1,206	
8:15 AM	0	79	47	0	0	0	59	14	0	0	0	0	0	15	0	89	303	1,251	
8:30 AM	0	71	49	0	0	0	57	22	0	0	0	0	0	19	0	94	312	1,276	
8:45 AM	0	77	45	0	0	0	55	27	0	0	0	0	0	20	0	85	309	1,254	
Count Total	0	550	434	0	0	0	455	140	0	0	0	0	2	115	0	647	2,343	0	
Peak Hour	All	0	305	225	0	0	0	246	68	0	0	0	0	1	70	0	361	1,276	0
	HV	0	17	21	0	0	0	18	3	0	0	0	0	0	5	0	16	80	0
	HV%	-	6%	9%	-	-	-	7%	4%	-	-	-	-	0%	7%	-	4%	6%	0

Note: Two-hour count summary volumes include heavy vehicles but exclude bicycles in overall count.

Interval Start	Heavy Vehicle Totals					Bicycles					Pedestrians (Crossing Leg)				
	EB	WB	NB	SB	Total	EB	WB	NB	SB	Total	East	West	North	South	Total
7:00 AM	5	6	0	4	15	0	0	0	0	0	0	0	0	0	0
7:15 AM	13	5	0	5	23	0	0	0	0	0	0	0	0	0	0
7:30 AM	17	7	0	5	29	0	0	0	0	0	0	0	0	0	0
<b>7:45 AM</b>	<b>10</b>	<b>9</b>	<b>0</b>	<b>4</b>	<b>23</b>	<b>0</b>	<b>0</b>	<b>0</b>	<b>0</b>	<b>0</b>	<b>0</b>	<b>0</b>	<b>0</b>	<b>0</b>	<b>0</b>
8:00 AM	10	4	0	9	23	0	0	0	0	0	0	0	0	0	0
8:15 AM	12	4	0	3	19	0	0	0	0	0	0	0	0	0	0
8:30 AM	6	4	0	5	15	0	0	0	0	0	0	0	0	0	0
8:45 AM	13	1	0	3	17	0	0	0	0	0	0	0	0	0	0
Count Total	86	40	0	38	164	0	0	0	0	0	0	0	0	0	0
Peak Hr	38	21	0	21	80	0	0	0	0	0	0	0	0	0	0

<b>Two-Hour Count Summaries - Heavy Vehicles</b>																		
Interval Start	Shiloh Rd				Shiloh Rd				n/a				Hembree Ln				15-min Total	Rolling One Hour
	Eastbound				Westbound				Northbound				Southbound					
	UT	LT	TH	RT	UT	LT	TH	RT	UT	LT	TH	RT	UT	LT	TH	RT		
7:00 AM	0	2	3	0	0	0	6	0	0	0	0	0	0	0	0	4	15	0
7:15 AM	0	3	10	0	0	0	5	0	0	0	0	0	0	0	0	5	23	0
7:30 AM	0	10	7	0	0	0	5	2	0	0	0	0	0	0	0	5	29	0
<b>7:45 AM</b>	<b>0</b>	<b>4</b>	<b>6</b>	<b>0</b>	<b>0</b>	<b>0</b>	<b>7</b>	<b>2</b>	<b>0</b>	<b>0</b>	<b>0</b>	<b>0</b>	<b>0</b>	<b>2</b>	<b>0</b>	<b>2</b>	<b>23</b>	<b>90</b>
8:00 AM	0	7	3	0	0	0	4	0	0	0	0	0	0	2	0	7	23	98
8:15 AM	0	4	8	0	0	0	3	1	0	0	0	0	0	0	0	3	19	94
8:30 AM	0	2	4	0	0	0	4	0	0	0	0	0	0	1	0	4	15	80
8:45 AM	0	7	6	0	0	0	1	0	0	0	0	0	0	0	0	3	17	74
Count Total	0	39	47	0	0	0	35	5	0	0	0	0	0	5	0	33	164	0
Peak Hour	0	17	21	0	0	0	18	3	0	0	0	0	0	5	0	16	80	0
<b>Two-Hour Count Summaries - Bikes</b>																		
Interval Start	Shiloh Rd			Shiloh Rd			n/a			Hembree Ln			15-min Total	Rolling One Hour				
	Eastbound			Westbound			Northbound			Southbound								
	LT	TH	RT	LT	TH	RT	LT	TH	RT	LT	TH	RT						
7:00 AM	0	0	0	0	0	0	0	0	0	0	0	0	0	0	0	0	0	0
7:15 AM	0	0	0	0	0	0	0	0	0	0	0	0	0	0	0	0	0	0
7:30 AM	0	0	0	0	0	0	0	0	0	0	0	0	0	0	0	0	0	0
<b>7:45 AM</b>	<b>0</b>	<b>0</b>	<b>0</b>	<b>0</b>	<b>0</b>	<b>0</b>	<b>0</b>	<b>0</b>	<b>0</b>	<b>0</b>	<b>0</b>	<b>0</b>	<b>0</b>	<b>0</b>	<b>0</b>	<b>0</b>	<b>0</b>	<b>0</b>
8:00 AM	0	0	0	0	0	0	0	0	0	0	0	0	0	0	0	0	0	0
8:15 AM	0	0	0	0	0	0	0	0	0	0	0	0	0	0	0	0	0	0
8:30 AM	0	0	0	0	0	0	0	0	0	0	0	0	0	0	0	0	0	0
8:45 AM	0	0	0	0	0	0	0	0	0	0	0	0	0	0	0	0	0	0
Count Total	0	0	0	0	0	0	0	0	0	0	0	0	0	0	0	0	0	0
Peak Hour	0	0	0	0	0	0	0	0	0	0	0	0	0	0	0	0	0	0
<i>Note: U-Turn volumes for bikes are included in Left-Turn, if any.</i>																		

### US-101 NB Ramps Shiloh Rd



Date: 07/28/2022  
 Count Period: 7:00 AM to 9:00 AM  
 Peak Hour: 7:30 AM to 8:30 AM

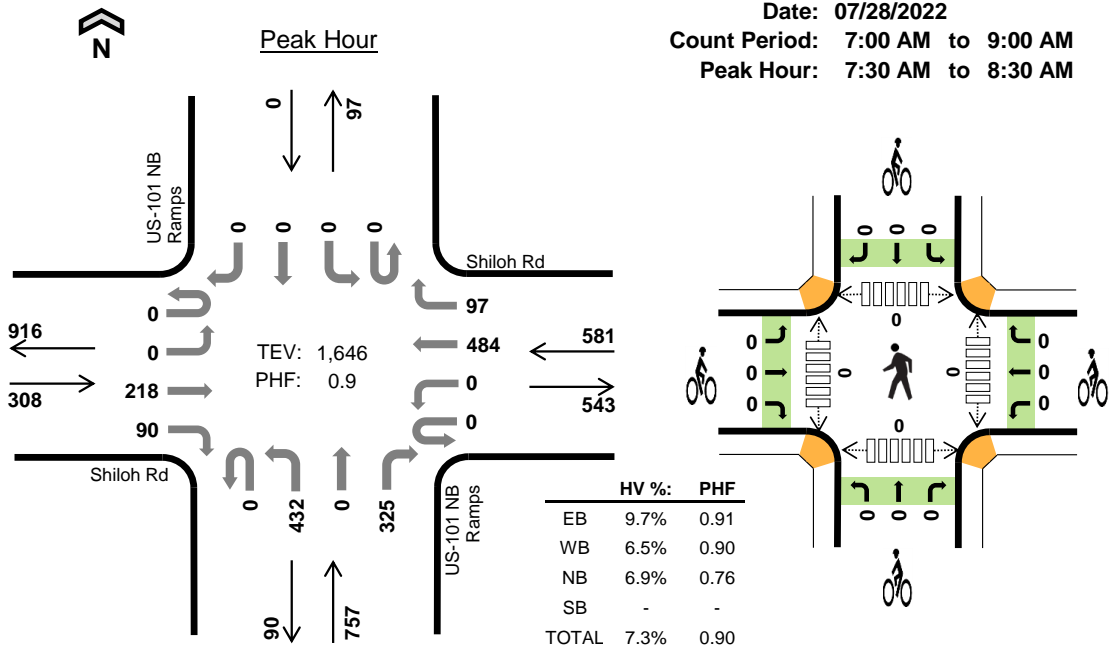

#### Two-Hour Count Summaries

Interval Start	Shiloh Rd Eastbound				Shiloh Rd Westbound				US-101 NB Ramps Northbound				US-101 NB Ramps Southbound				15-min Total	Rolling One Hour	
	UT	LT	TH	RT	UT	LT	TH	RT	UT	LT	TH	RT	UT	LT	TH	RT			
7:00 AM	0	0	32	20	0	0	94	17	0	107	0	51	0	0	0	0	321	0	
7:15 AM	0	0	38	15	0	0	104	21	0	97	0	74	0	0	0	0	349	0	
7:30 AM	0	0	47	33	0	0	101	24	0	102	0	85	0	0	0	0	392	0	
7:45 AM	0	0	48	14	0	0	119	27	0	144	0	104	0	0	0	0	456	1,518	
8:00 AM	0	0	60	25	0	0	134	27	0	104	0	81	0	0	0	0	431	1,628	
8:15 AM	0	0	63	18	0	0	130	19	0	82	0	55	0	0	0	0	367	1,646	
8:30 AM	0	0	47	13	0	0	117	36	0	88	0	71	0	0	0	0	372	1,626	
8:45 AM	0	0	53	27	0	0	110	29	0	115	0	73	0	0	0	0	407	1,577	
Count Total	0	0	388	165	0	0	909	200	0	839	0	594	0	0	0	0	3,095	0	
Peak Hour	All	0	0	218	90	0	0	484	97	0	432	0	325	0	0	0	0	1,646	0
	HV	0	0	20	10	0	0	33	5	0	37	0	15	0	0	0	0	120	0
	HV%	-	-	9%	11%	-	-	7%	5%	-	9%	-	5%	-	-	-	-	7%	0

Note: Two-hour count summary volumes include heavy vehicles but exclude bicycles in overall count.

Interval Start	Heavy Vehicle Totals					Bicycles					Pedestrians (Crossing Leg)				
	EB	WB	NB	SB	Total	EB	WB	NB	SB	Total	East	West	North	South	Total
7:00 AM	3	8	12	0	23	0	0	0	0	0	0	0	0	0	0
7:15 AM	8	10	15	0	33	0	0	0	0	0	0	0	0	0	0
7:30 AM	7	9	14	0	30	0	0	0	0	0	0	0	0	0	0
7:45 AM	9	11	13	0	33	0	0	0	0	0	0	0	0	0	0
8:00 AM	6	12	12	0	30	0	0	0	0	0	0	0	0	0	0
8:15 AM	8	6	13	0	27	0	0	0	0	0	0	0	0	0	0
8:30 AM	5	7	17	0	29	0	0	0	0	0	0	0	0	0	0
8:45 AM	9	2	9	0	20	0	0	0	0	0	0	0	0	0	0
Count Total	55	65	105	0	225	0	0	0	0	0	0	0	0	0	0
Peak Hour	30	38	52	0	120	0	0	0	0	0	0	0	0	0	0

<b>Two-Hour Count Summaries - Heavy Vehicles</b>																		
Interval Start	Shiloh Rd				Shiloh Rd				US-101 NB Ramps				US-101 NB Ramps				15-min Total	Rolling One Hour
	Eastbound				Westbound				Northbound				Southbound					
	UT	LT	TH	RT	UT	LT	TH	RT	UT	LT	TH	RT	UT	LT	TH	RT		
7:00 AM	0	0	2	1	0	0	6	2	0	8	0	4	0	0	0	0	23	0
7:15 AM	0	0	6	2	0	0	8	2	0	8	0	7	0	0	0	0	33	0
7:30 AM	0	0	4	3	0	0	8	1	0	9	0	5	0	0	0	0	30	0
7:45 AM	0	0	6	3	0	0	10	1	0	11	0	2	0	0	0	0	33	119
8:00 AM	0	0	4	2	0	0	9	3	0	9	0	3	0	0	0	0	30	126
8:15 AM	0	0	6	2	0	0	6	0	0	8	0	5	0	0	0	0	27	120
8:30 AM	0	0	2	3	0	0	6	1	0	13	0	4	0	0	0	0	29	119
8:45 AM	0	0	6	3	0	0	2	0	0	5	0	4	0	0	0	0	20	106
Count Total	0	0	36	19	0	0	55	10	0	71	0	34	0	0	0	0	225	0
Peak Hour	0	0	20	10	0	0	33	5	0	37	0	15	0	0	0	0	120	0

<b>Two-Hour Count Summaries - Bikes</b>																	
Interval Start	Shiloh Rd			Shiloh Rd			US-101 NB Ramps			US-101 NB Ramps			15-min Total	Rolling One Hour			
	Eastbound			Westbound			Northbound			Southbound							
	LT	TH	RT	LT	TH	RT	LT	TH	RT	LT	TH	RT					
7:00 AM	0	0	0	0	0	0	0	0	0	0	0	0	0	0	0	0	0
7:15 AM	0	0	0	0	0	0	0	0	0	0	0	0	0	0	0	0	0
7:30 AM	0	0	0	0	0	0	0	0	0	0	0	0	0	0	0	0	0
7:45 AM	0	0	0	0	0	0	0	0	0	0	0	0	0	0	0	0	0
8:00 AM	0	0	0	0	0	0	0	0	0	0	0	0	0	0	0	0	0
8:15 AM	0	0	0	0	0	0	0	0	0	0	0	0	0	0	0	0	0
8:30 AM	0	0	0	0	0	0	0	0	0	0	0	0	0	0	0	0	0
8:45 AM	0	0	0	0	0	0	0	0	0	0	0	0	0	0	0	0	0
Count Total	0	0	0	0	0	0	0	0	0	0	0	0	0	0	0	0	0
Peak Hour	0	0	0	0	0	0	0	0	0	0	0	0	0	0	0	0	0

Note: U-Turn volumes for bikes are included in Left-Turn, if any.



## US-101 SB Ramps Shiloh Rd



Date: 07/28/2022  
 Count Period: 7:00 AM to 9:00 AM  
 Peak Hour: 7:30 AM to 8:30 AM

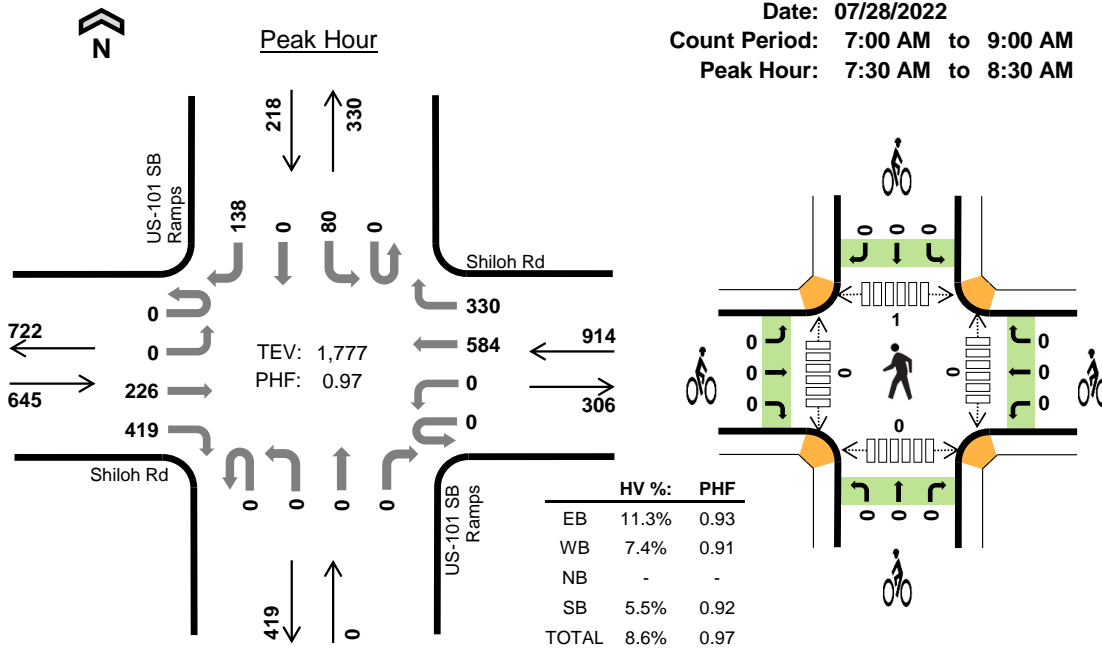

### Two-Hour Count Summaries

Interval Start	Shiloh Rd Eastbound				Shiloh Rd Westbound				US-101 SB Ramps Northbound				US-101 SB Ramps Southbound				15-min Total	Rolling One Hour	
	UT	LT	TH	RT	UT	LT	TH	RT	UT	LT	TH	RT	UT	LT	TH	RT			
7:00 AM	0	0	42	67	0	0	137	67	0	0	0	0	0	10	0	29	352	0	
7:15 AM	0	0	40	86	0	0	123	70	0	0	0	0	0	14	0	36	369	0	
7:30 AM	0	0	65	108	0	0	132	76	0	0	0	0	0	13	0	32	426	0	
7:45 AM	0	0	48	97	0	0	165	86	0	0	0	0	0	20	0	39	455	1,602	
8:00 AM	0	0	63	94	0	0	161	83	0	0	0	0	0	22	0	35	458	1,708	
8:15 AM	0	0	50	120	0	0	126	85	0	0	0	0	0	25	0	32	438	1,777	
8:30 AM	0	0	48	118	0	0	128	80	0	0	0	0	0	14	0	34	422	1,773	
8:45 AM	0	0	57	113	0	0	143	75	0	0	0	0	0	25	0	40	453	1,771	
Count Total	0	0	413	803	0	0	1,115	622	0	0	0	0	0	143	0	277	3,373	0	
Peak Hour	All	0	0	226	419	0	0	584	330	0	0	0	0	0	80	0	138	1,777	0
	HV	0	0	34	39	0	0	54	14	0	0	0	0	0	4	0	8	153	0
	HV%	-	-	15%	9%	-	-	9%	4%	-	-	-	-	-	5%	-	6%	9%	0

Note: Two-hour count summary volumes include heavy vehicles but exclude bicycles in overall count.

Interval Start	Heavy Vehicle Totals					Bicycles					Pedestrians (Crossing Leg)				
	EB	WB	NB	SB	Total	EB	WB	NB	SB	Total	East	West	North	South	Total
7:00 AM	14	15	0	2	31	0	0	0	0	0	0	0	0	0	0
7:15 AM	24	15	0	3	42	0	0	0	0	0	0	0	0	0	0
7:30 AM	25	16	0	1	42	0	0	0	0	0	0	0	0	0	0
7:45 AM	25	24	0	3	52	0	0	0	0	0	0	0	0	0	0
8:00 AM	10	13	0	3	26	0	0	0	0	0	0	0	0	0	0
8:15 AM	13	15	0	5	33	0	0	0	0	0	0	0	1	0	1
8:30 AM	20	19	0	3	42	0	0	0	0	0	0	0	0	0	0
8:45 AM	37	8	0	4	49	1	0	0	0	1	0	0	0	0	0
Count Total	168	125	0	24	317	1	0	0	0	1	0	0	1	0	1
Peak Hour	73	68	0	12	153	0	0	0	0	0	0	0	1	0	1

<b>Two-Hour Count Summaries - Heavy Vehicles</b>																		
Interval Start	Shiloh Rd				Shiloh Rd				US-101 SB Ramps				US-101 SB Ramps				15-min Total	Rolling One Hour
	Eastbound				Westbound				Northbound				Southbound					
	UT	LT	TH	RT	UT	LT	TH	RT	UT	LT	TH	RT	UT	LT	TH	RT		
7:00 AM	0	0	3	11	0	0	14	1	0	0	0	0	0	0	0	2	31	0
7:15 AM	0	0	10	14	0	0	12	3	0	0	0	0	0	0	0	3	42	0
7:30 AM	0	0	10	15	0	0	13	3	0	0	0	0	0	1	0	0	42	0
7:45 AM	0	0	13	12	0	0	17	7	0	0	0	0	0	0	0	3	52	167
8:00 AM	0	0	8	2	0	0	12	1	0	0	0	0	0	1	0	2	26	162
8:15 AM	0	0	3	10	0	0	12	3	0	0	0	0	0	2	0	3	33	153
8:30 AM	0	0	4	16	0	0	17	2	0	0	0	0	0	1	0	2	42	153
8:45 AM	0	0	8	29	0	0	8	0	0	0	0	0	0	1	0	3	49	150
Count Total	0	0	59	109	0	0	105	20	0	0	0	0	0	6	0	18	317	0
Peak Hour	0	0	34	39	0	0	54	14	0	0	0	0	0	4	0	8	153	0

<b>Two-Hour Count Summaries - Bikes</b>																	
Interval Start	Shiloh Rd			Shiloh Rd			US-101 SB Ramps			US-101 SB Ramps			15-min Total	Rolling One Hour			
	Eastbound			Westbound			Northbound			Southbound							
	LT	TH	RT	LT	TH	RT	LT	TH	RT	LT	TH	RT					
7:00 AM	0	0	0	0	0	0	0	0	0	0	0	0	0	0	0	0	0
7:15 AM	0	0	0	0	0	0	0	0	0	0	0	0	0	0	0	0	0
7:30 AM	0	0	0	0	0	0	0	0	0	0	0	0	0	0	0	0	0
7:45 AM	0	0	0	0	0	0	0	0	0	0	0	0	0	0	0	0	0
8:00 AM	0	0	0	0	0	0	0	0	0	0	0	0	0	0	0	0	0
8:15 AM	0	0	0	0	0	0	0	0	0	0	0	0	0	0	0	0	0
8:30 AM	0	0	0	0	0	0	0	0	0	0	0	0	0	0	0	0	0
8:45 AM	0	1	0	0	0	0	0	0	0	0	0	0	0	0	0	1	1
Count Total	0	1	0	0	0	0	0	0	0	0	0	0	0	0	0	1	0
Peak Hour	0	0	0	0	0	0	0	0	0	0	0	0	0	0	0	0	0

Note: U-Turn volumes for bikes are included in Left-Turn, if any.

# Caletti Ave Shiloh Rd



Peak Hour

Date: 07/28/2022  
Count Period: 7:00 AM to 9:00 AM  
Peak Hour: 7:30 AM to 8:30 AM

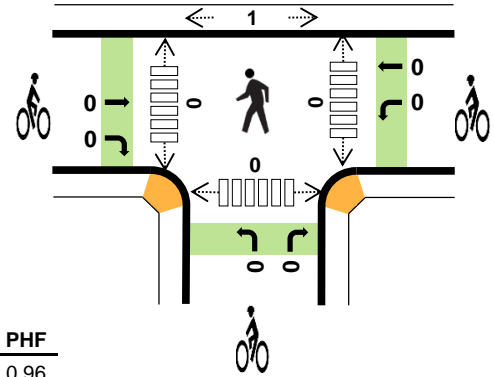
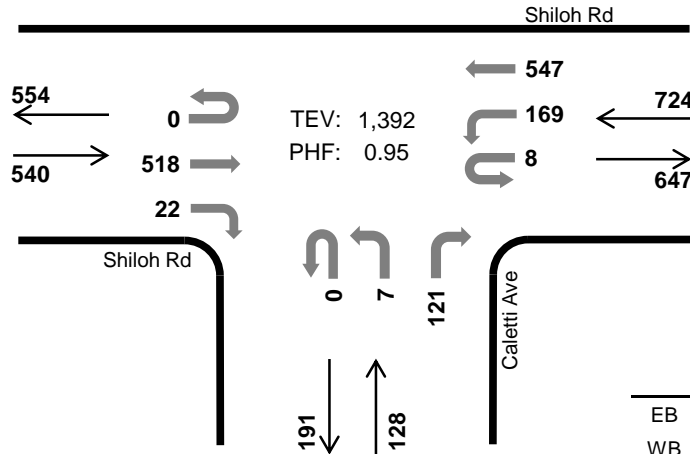

	HV %:	PHF
EB	5.2%	0.96
WB	7.6%	0.87
NB	31.3%	0.84
SB	-	-
TOTAL	8.8%	0.95

## Two-Hour Count Summaries

Interval Start	Shiloh Rd Eastbound				Shiloh Rd Westbound				Caletti Ave Northbound				n/a Southbound				15-min Total	Rolling One Hour	
	UT	LT	TH	RT	UT	LT	TH	RT	UT	LT	TH	RT	UT	LT	TH	RT			
7:00 AM	0	0	91	5	0	55	109	0	0	1	0	20	0	0	0	0	281	0	
7:15 AM	0	0	97	4	2	42	116	0	0	2	0	28	0	0	0	0	291	0	
7:30 AM	0	0	134	4	2	38	125	0	0	1	0	37	0	0	0	0	341	0	
7:45 AM	0	0	115	7	2	50	157	0	0	4	0	30	0	0	0	0	365	1,278	
8:00 AM	0	0	131	9	0	49	143	0	0	0	0	26	0	0	0	0	358	1,355	
8:15 AM	0	0	138	2	4	32	122	0	0	2	0	28	0	0	0	0	328	1,392	
8:30 AM	0	0	141	6	1	27	134	0	0	1	0	27	0	0	0	0	337	1,388	
8:45 AM	0	0	114	1	0	22	164	0	0	3	0	55	0	0	0	0	359	1,382	
Count Total	0	0	961	38	11	315	1,070	0	0	14	0	251	0	0	0	0	2,660	0	
Peak Hour	All	0	0	518	22	8	169	547	0	0	7	0	121	0	0	0	0	1,392	0
	HV	0	0	23	5	0	30	25	0	0	0	0	40	0	0	0	0	123	0
	HV%	-	-	4%	23%	0%	18%	5%	-	-	0%	-	33%	-	-	-	-	9%	0

Note: Two-hour count summary volumes include heavy vehicles but exclude bicycles in overall count.

Interval Start	Heavy Vehicle Totals					Bicycles					Pedestrians (Crossing Leg)				
	EB	WB	NB	SB	Total	EB	WB	NB	SB	Total	East	West	North	South	Total
7:00 AM	4	16	9	0	29	0	0	0	0	0	0	0	0	0	0
7:15 AM	14	12	12	0	38	0	0	0	0	0	0	0	0	0	0
7:30 AM	10	13	12	0	35	0	0	0	0	0	0	0	0	0	0
7:45 AM	7	15	13	0	35	0	0	0	0	0	0	0	0	0	0
8:00 AM	5	14	7	0	26	0	0	0	0	0	0	0	1	0	1
8:15 AM	6	13	8	0	27	0	0	0	0	0	0	0	0	0	0
8:30 AM	6	17	16	0	39	0	0	0	0	0	0	0	0	0	0
8:45 AM	15	9	27	0	51	1	0	0	0	1	0	0	1	0	1
Count Total	67	109	104	0	280	1	0	0	0	1	0	0	2	0	2
Peak Hr	28	55	40	0	123	0	0	0	0	0	0	0	1	0	1

**Two-Hour Count Summaries - Heavy Vehicles**

Interval Start	Shiloh Rd				Shiloh Rd				Caletti Ave				n/a				15-min Total	Rolling One Hour
	Eastbound				Westbound				Northbound				Southbound					
	UT	LT	TH	RT	UT	LT	TH	RT	UT	LT	TH	RT	UT	LT	TH	RT		
7:00 AM	0	0	4	0	0	9	7	0	0	0	0	9	0	0	0	0	29	0
7:15 AM	0	0	13	1	0	8	4	0	0	0	0	12	0	0	0	0	38	0
7:30 AM	0	0	10	0	0	7	6	0	0	0	0	12	0	0	0	0	35	0
7:45 AM	0	0	5	2	0	8	7	0	0	0	0	13	0	0	0	0	35	137
8:00 AM	0	0	3	2	0	7	7	0	0	0	0	7	0	0	0	0	26	134
8:15 AM	0	0	5	1	0	8	5	0	0	0	0	8	0	0	0	0	27	123
8:30 AM	0	0	5	1	1	7	9	0	0	0	0	16	0	0	0	0	39	127
8:45 AM	0	0	14	1	0	5	4	0	0	1	0	26	0	0	0	0	51	143
Count Total	0	0	59	8	1	59	49	0	0	1	0	103	0	0	0	0	280	0
Peak Hour	0	0	23	5	0	30	25	0	0	0	0	40	0	0	0	0	123	0

**Two-Hour Count Summaries - Bikes**

Interval Start	Shiloh Rd			Shiloh Rd			Caletti Ave			n/a			15-min Total	Rolling One Hour
	Eastbound			Westbound			Northbound			Southbound				
	LT	TH	RT	LT	TH	RT	LT	TH	RT	LT	TH	RT		
7:00 AM	0	0	0	0	0	0	0	0	0	0	0	0	0	0
7:15 AM	0	0	0	0	0	0	0	0	0	0	0	0	0	0
7:30 AM	0	0	0	0	0	0	0	0	0	0	0	0	0	0
7:45 AM	0	0	0	0	0	0	0	0	0	0	0	0	0	0
8:00 AM	0	0	0	0	0	0	0	0	0	0	0	0	0	0
8:15 AM	0	0	0	0	0	0	0	0	0	0	0	0	0	0
8:30 AM	0	0	0	0	0	0	0	0	0	0	0	0	0	0
8:45 AM	0	0	1	0	0	0	0	0	0	0	0	0	1	1
Count Total	0	0	1	0	0	0	0	0	0	0	0	0	1	0
Peak Hour	0	0	0	0	0	0	0	0	0	0	0	0	0	0

Note: U-Turn volumes for bikes are included in Left-Turn, if any.

### Conde Ln Shiloh Rd



Peak Hour

Date: 07/28/2022  
Count Period: 7:00 AM to 9:00 AM  
Peak Hour: 7:45 AM to 8:45 AM

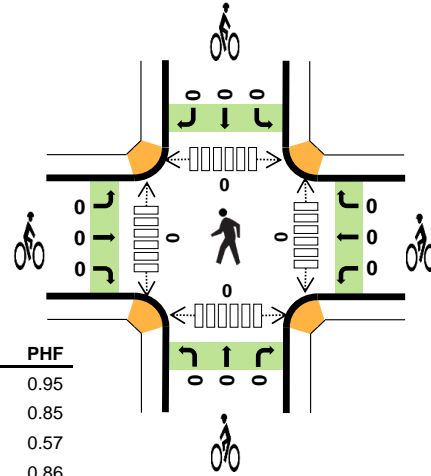
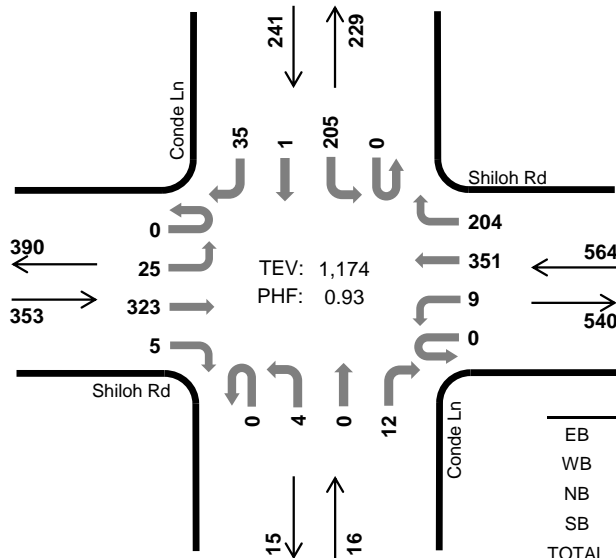

	HV %:	PHF
EB	4.8%	0.95
WB	5.0%	0.85
NB	18.8%	0.57
SB	5.4%	0.86
TOTAL	5.2%	0.93

#### Two-Hour Count Summaries

Interval Start	Shiloh Rd Eastbound				Shiloh Rd Westbound				Conde Ln Northbound				Conde Ln Southbound				15-min Total	Rolling One Hour	
	UT	LT	TH	RT	UT	LT	TH	RT	UT	LT	TH	RT	UT	LT	TH	RT			
7:00 AM	0	1	63	0	0	3	67	43	1	1	0	5	0	30	1	4	219	0	
7:15 AM	0	8	58	1	0	1	60	54	0	0	0	7	0	35	1	8	233	0	
7:30 AM	0	15	83	0	0	4	75	39	0	0	0	7	0	47	0	3	273	0	
<b>7:45 AM</b>	<b>0</b>	<b>5</b>	<b>86</b>	<b>2</b>	<b>0</b>	<b>3</b>	<b>107</b>	<b>55</b>	<b>0</b>	<b>2</b>	<b>0</b>	<b>5</b>	<b>0</b>	<b>36</b>	<b>0</b>	<b>14</b>	<b>315</b>	1,040	
8:00 AM	0	9	74	0	0	3	80	57	0	2	0	1	0	57	1	12	296	1,117	
8:15 AM	0	4	84	1	0	1	76	49	0	0	0	5	0	50	0	5	275	1,159	
8:30 AM	0	7	79	2	0	2	88	43	0	0	0	1	0	62	0	4	288	1,174	
8:45 AM	0	8	72	0	0	3	102	60	0	2	0	6	0	38	0	7	298	1,157	
Count Total	0	57	599	6	0	20	655	400	1	7	0	37	0	355	3	57	2,197	0	
Peak Hour	All	0	25	323	5	0	9	351	204	0	4	0	12	0	205	1	35	1,174	0
	HV	0	3	12	2	0	1	16	11	0	2	0	1	0	9	1	3	61	0
	HV%	-	12%	4%	40%	-	11%	5%	5%	-	50%	-	8%	-	4%	100%	9%	5%	0

Note: Two-hour count summary volumes include heavy vehicles but exclude bicycles in overall count.

Interval Start	Heavy Vehicle Totals					Bicycles					Pedestrians (Crossing Leg)				
	EB	WB	NB	SB	Total	EB	WB	NB	SB	Total	East	West	North	South	Total
7:00 AM	2	7	1	2	12	0	0	0	0	0	0	0	0	0	0
7:15 AM	3	5	1	10	19	0	0	0	0	0	0	0	1	2	3
7:30 AM	6	5	1	5	17	0	0	0	0	0	0	0	0	0	0
<b>7:45 AM</b>	<b>5</b>	<b>8</b>	<b>3</b>	<b>4</b>	<b>20</b>	<b>0</b>	<b>0</b>	<b>0</b>	<b>0</b>	<b>0</b>	<b>0</b>	<b>0</b>	<b>0</b>	<b>0</b>	<b>0</b>
8:00 AM	5	5	0	2	12	0	0	0	0	0	0	0	0	0	0
8:15 AM	2	6	0	4	12	0	0	0	0	0	0	0	0	0	0
8:30 AM	5	9	0	3	17	0	0	0	0	0	0	0	0	0	0
8:45 AM	5	5	1	12	23	0	0	0	1	1	0	0	0	0	0
Count Total	33	50	7	42	132	0	0	0	1	1	0	0	1	2	3
Peak Hour	17	28	3	13	61	0	0	0	0	0	0	0	0	0	0

<b>Two-Hour Count Summaries - Heavy Vehicles</b>																		
Interval Start	Shiloh Rd				Shiloh Rd				Conde Ln				Conde Ln				15-min Total	Rolling One Hour
	Eastbound				Westbound				Northbound				Southbound					
	UT	LT	TH	RT	UT	LT	TH	RT	UT	LT	TH	RT	UT	LT	TH	RT		
7:00 AM	0	0	2	0	0	0	4	3	0	1	0	0	0	2	0	0	12	0
7:15 AM	0	1	2	0	0	0	2	3	0	0	0	1	0	9	1	0	19	0
7:30 AM	0	3	3	0	0	0	3	2	0	0	0	1	0	5	0	0	17	0
<b>7:45 AM</b>	<b>0</b>	<b>1</b>	<b>4</b>	<b>0</b>	<b>0</b>	<b>1</b>	<b>6</b>	<b>1</b>	<b>0</b>	<b>2</b>	<b>0</b>	<b>1</b>	<b>0</b>	<b>2</b>	<b>0</b>	<b>2</b>	<b>20</b>	68
8:00 AM	0	1	4	0	0	0	1	4	0	0	0	0	0	0	1	1	12	68
8:15 AM	0	0	1	1	0	0	3	3	0	0	0	0	0	4	0	0	12	61
8:30 AM	0	1	3	1	0	0	6	3	0	0	0	0	0	3	0	0	17	61
8:45 AM	0	0	5	0	0	0	3	2	0	1	0	0	0	10	0	2	23	64
Count Total	0	7	24	2	0	1	28	21	0	4	0	3	0	35	2	5	132	0
Peak Hour	0	3	12	2	0	1	16	11	0	2	0	1	0	9	1	3	61	0

<b>Two-Hour Count Summaries - Bikes</b>																		
Interval Start	Shiloh Rd			Shiloh Rd			Conde Ln			Conde Ln			15-min Total	Rolling One Hour				
	Eastbound			Westbound			Northbound			Southbound								
	LT	TH	RT	LT	TH	RT	LT	TH	RT	LT	TH	RT						
7:00 AM	0	0	0	0	0	0	0	0	0	0	0	0	0	0	0	0	0	0
7:15 AM	0	0	0	0	0	0	0	0	0	0	0	0	0	0	0	0	0	0
7:30 AM	0	0	0	0	0	0	0	0	0	0	0	0	0	0	0	0	0	0
<b>7:45 AM</b>	<b>0</b>	<b>0</b>	<b>0</b>	<b>0</b>	<b>0</b>	<b>0</b>	<b>0</b>	<b>0</b>	<b>0</b>	<b>0</b>	<b>0</b>	<b>0</b>	<b>0</b>	<b>0</b>	<b>0</b>	<b>0</b>	<b>0</b>	0
8:00 AM	0	0	0	0	0	0	0	0	0	0	0	0	0	0	0	0	0	0
8:15 AM	0	0	0	0	0	0	0	0	0	0	0	0	0	0	0	0	0	0
8:30 AM	0	0	0	0	0	0	0	0	0	0	0	0	0	0	0	0	0	0
8:45 AM	0	0	0	0	0	0	0	0	0	0	0	0	1	0	0	1	1	1
Count Total	0	0	0	0	0	0	0	0	0	0	0	0	1	0	0	1	1	0
Peak Hour	0	0	0	0	0	0	0	0	0	0	0	0	0	0	0	0	0	0

Note: U-Turn volumes for bikes are included in Left-Turn, if any.

### Gridley Dr Shiloh Rd

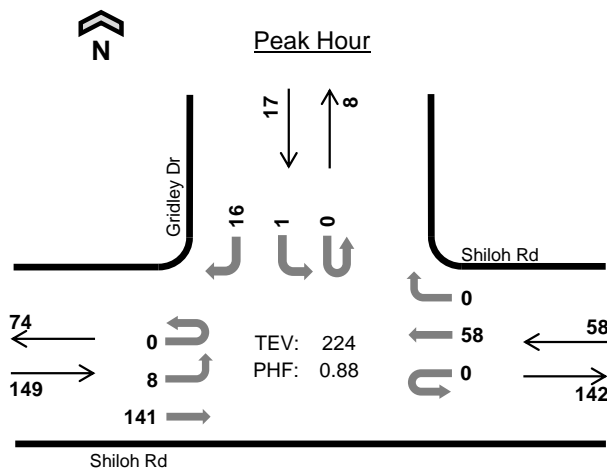

Date: 07/28/2022  
 Count Period: 7:00 AM to 9:00 AM  
 Peak Hour: 7:15 AM to 8:15 AM

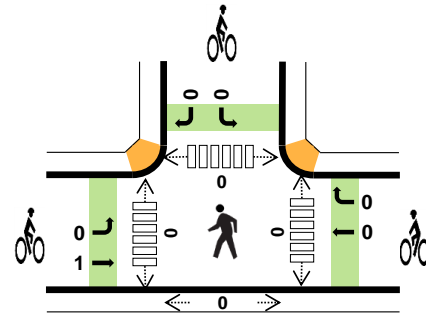

	HV %:	PHF
EB	2.0%	0.91
WB	3.4%	0.85
NB	-	-
SB	0.0%	0.71
TOTAL	2.2%	0.88

#### Two-Hour Count Summaries

Interval Start	Shiloh Rd Eastbound				Shiloh Rd Westbound				N/A Northbound				Gridley Dr Southbound				15-min Total	Rolling One Hour	
	UT	LT	TH	RT	UT	LT	TH	RT	UT	LT	TH	RT	UT	LT	TH	RT			
7:00 AM	0	1	25	0	0	0	11	0	0	0	0	0	0	0	0	2	39	0	
7:15 AM	0	2	30	0	0	0	12	0	0	0	0	0	0	1	0	5	50	0	
7:30 AM	0	1	37	0	0	0	12	0	0	0	0	0	0	0	0	3	53	0	
7:45 AM	0	3	38	0	0	0	17	0	0	0	0	0	0	0	0	6	64	206	
8:00 AM	0	2	36	0	0	0	17	0	0	0	0	0	0	0	0	2	57	224	
8:15 AM	0	0	29	0	0	0	17	1	0	0	0	0	0	0	0	3	50	224	
8:30 AM	0	3	33	0	0	0	10	0	0	0	0	0	0	0	0	4	50	221	
8:45 AM	0	0	32	0	0	0	24	0	0	0	0	0	0	0	0	5	61	218	
Count Total	0	12	260	0	0	0	120	1	0	0	0	0	0	1	0	30	424	0	
Peak Hour	All	0	8	141	0	0	0	58	0	0	0	0	0	0	1	0	16	224	0
	HV	0	0	3	0	0	0	2	0	0	0	0	0	0	0	0	0	5	0
	HV%	-	0%	2%	-	-	-	3%	-	-	-	-	-	-	0%	-	0%	2%	0

Note: Two-hour count summary volumes include heavy vehicles but exclude bicycles in overall count.

Interval Start	Heavy Vehicle Totals					Bicycles					Pedestrians (Crossing Leg)				
	EB	WB	NB	SB	Total	EB	WB	NB	SB	Total	East	West	North	South	Total
7:00 AM	2	0	0	0	2	0	0	0	0	0	0	0	0	0	0
7:15 AM	0	0	0	0	0	1	0	0	0	1	0	0	0	0	0
7:30 AM	2	0	0	0	2	0	0	0	0	0	0	0	0	0	0
7:45 AM	1	1	0	0	2	0	0	0	0	0	0	0	0	0	0
8:00 AM	0	1	0	0	1	0	0	0	0	0	0	0	0	0	0
8:15 AM	0	1	0	0	1	0	0	0	0	0	0	0	1	0	1
8:30 AM	4	1	0	0	5	0	2	0	0	2	0	0	2	0	2
8:45 AM	3	0	0	0	3	0	1	0	0	1	0	0	0	0	0
Count Total	12	4	0	0	16	1	3	0	0	4	0	0	3	0	3
Peak Hr	3	2	0	0	5	1	0	0	0	1	0	0	0	0	0

<b>Two-Hour Count Summaries - Heavy Vehicles</b>																		
Interval Start	Shiloh Rd				Shiloh Rd				N/A				Gridley Dr				15-min Total	Rolling One Hour
	Eastbound				Westbound				Northbound				Southbound					
	UT	LT	TH	RT	UT	LT	TH	RT	UT	LT	TH	RT	UT	LT	TH	RT		
7:00 AM	0	0	2	0	0	0	0	0	0	0	0	0	0	0	0	0	2	0
7:15 AM	0	0	0	0	0	0	0	0	0	0	0	0	0	0	0	0	0	0
7:30 AM	0	0	2	0	0	0	0	0	0	0	0	0	0	0	0	0	2	0
7:45 AM	0	0	1	0	0	0	1	0	0	0	0	0	0	0	0	0	2	6
8:00 AM	0	0	0	0	0	0	1	0	0	0	0	0	0	0	0	0	1	5
8:15 AM	0	0	0	0	0	0	1	0	0	0	0	0	0	0	0	0	1	6
8:30 AM	0	1	3	0	0	0	1	0	0	0	0	0	0	0	0	0	5	9
8:45 AM	0	0	3	0	0	0	0	0	0	0	0	0	0	0	0	0	3	10
Count Total	0	1	11	0	0	0	4	0	0	0	0	0	0	0	0	0	16	0
Peak Hour	0	0	3	0	0	0	2	0	0	0	0	0	0	0	0	0	5	0

  

<b>Two-Hour Count Summaries - Bikes</b>																	
Interval Start	Shiloh Rd			Shiloh Rd			N/A			Gridley Dr			15-min Total	Rolling One Hour			
	Eastbound			Westbound			Northbound			Southbound							
	LT	TH	RT	LT	TH	RT	LT	TH	RT	LT	TH	RT					
7:00 AM	0	0	0	0	0	0	0	0	0	0	0	0	0	0	0	0	0
7:15 AM	0	1	0	0	0	0	0	0	0	0	0	0	0	0	0	1	0
7:30 AM	0	0	0	0	0	0	0	0	0	0	0	0	0	0	0	0	0
7:45 AM	0	0	0	0	0	0	0	0	0	0	0	0	0	0	0	0	1
8:00 AM	0	0	0	0	0	0	0	0	0	0	0	0	0	0	0	0	1
8:15 AM	0	0	0	0	0	0	0	0	0	0	0	0	0	0	0	0	0
8:30 AM	0	0	0	0	0	2	0	0	0	0	0	0	0	0	0	2	2
8:45 AM	0	0	0	0	0	1	0	0	0	0	0	0	0	0	0	1	3
Count Total	0	1	0	0	0	3	0	0	0	0	0	0	0	0	0	4	0
Peak Hour	0	1	0	0	0	0	0	0	0	0	0	0	0	0	0	1	0

Note: U-Turn volumes for bikes are included in Left-Turn, if any.



# Old Redwood Hwy Shiloh Neighborhood Church South

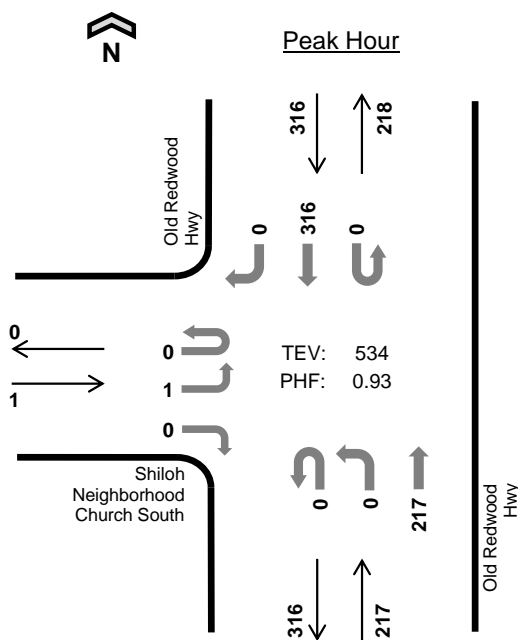

Date: 07/28/2022  
Count Period: 7:00 AM to 9:00 AM  
Peak Hour: 7:45 AM to 8:45 AM

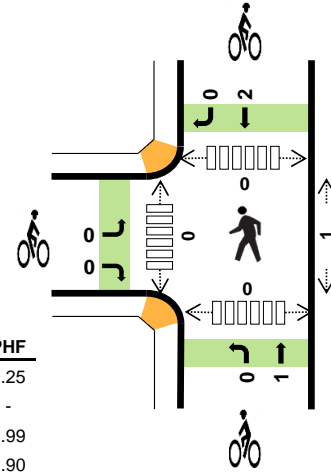

	HV %:	PHF
EB	0.0%	0.25
WB	-	-
NB	1.4%	0.99
SB	3.5%	0.90
TOTAL	2.6%	0.93

### Two-Hour Count Summaries

Interval Start	Shiloh Neighborhood Church South				n/a				Old Redwood Hwy				Old Redwood Hwy				15-min Total	Rolling One Hour	
	Eastbound				Westbound				Northbound				Southbound						
	UT	LT	TH	RT	UT	LT	TH	RT	UT	LT	TH	RT	UT	LT	TH	RT			
7:00 AM	0	0	0	0	0	0	0	0	0	0	41	0	0	0	52	0	93	0	
7:15 AM	0	0	0	0	0	0	0	0	0	0	38	0	0	0	69	0	107	0	
7:30 AM	0	1	0	0	0	0	0	0	0	0	54	0	0	0	68	0	123	0	
<b>7:45 AM</b>	<b>0</b>	<b>1</b>	<b>0</b>	<b>0</b>	<b>0</b>	<b>0</b>	<b>0</b>	<b>0</b>	<b>0</b>	<b>0</b>	<b>55</b>	<b>0</b>	<b>0</b>	<b>0</b>	<b>88</b>	<b>0</b>	<b>144</b>	<b>467</b>	
8:00 AM	0	0	0	0	0	0	0	0	0	0	52	0	0	0	84	0	136	510	
8:15 AM	0	0	0	0	0	0	0	0	0	0	55	0	0	0	68	0	123	526	
8:30 AM	0	0	0	0	0	0	0	0	0	0	55	0	0	0	76	0	131	534	
8:45 AM	0	0	0	0	0	0	0	0	0	0	69	0	0	0	66	0	135	525	
Count Total	0	2	0	0	0	0	0	0	0	0	419	0	0	0	571	0	992	0	
Peak Hour	All	0	1	0	0	0	0	0	0	0	0	217	0	0	0	316	0	534	0
	HV	0	0	0	0	0	0	0	0	0	0	3	0	0	0	11	0	14	0
	HV%	-	0%	-	-	-	-	-	-	-	-	1%	-	-	-	3%	-	3%	0

Note: Two-hour count summary volumes include heavy vehicles but exclude bicycles in overall count.

Interval Start	Heavy Vehicle Totals					Bicycles					Pedestrians (Crossing Leg)				
	EB	WB	NB	SB	Total	EB	WB	NB	SB	Total	East	West	North	South	Total
7:00 AM	0	0	2	1	3	0	0	1	0	1	1	0	0	0	1
7:15 AM	0	0	2	1	3	0	0	1	0	1	1	0	0	0	1
7:30 AM	0	0	2	0	2	0	0	0	0	0	0	0	0	0	0
<b>7:45 AM</b>	<b>0</b>	<b>0</b>	<b>0</b>	<b>2</b>	<b>2</b>	<b>0</b>	<b>0</b>	<b>0</b>	<b>0</b>	<b>0</b>	<b>0</b>	<b>0</b>	<b>0</b>	<b>0</b>	<b>0</b>
8:00 AM	0	0	1	3	4	0	0	0	1	1	0	0	0	0	0
8:15 AM	0	0	0	4	4	0	0	0	0	0	0	0	0	0	0
8:30 AM	0	0	2	2	4	0	0	1	1	2	1	0	0	0	1
8:45 AM	0	0	2	2	4	0	0	0	0	0	0	0	0	0	0
Count Total	0	0	11	15	26	0	0	3	2	5	3	0	0	0	3
Peak Hr	0	0	3	11	14	0	0	1	2	3	1	0	0	0	1

<b>Two-Hour Count Summaries - Heavy Vehicles</b>																		
Interval Start	Shiloh Neighborhood Church South				n/a				Old Redwood Hwy				Old Redwood Hwy				15-min Total	Rolling One Hour
	Eastbound				Westbound				Northbound				Southbound					
	UT	LT	TH	RT	UT	LT	TH	RT	UT	LT	TH	RT	UT	LT	TH	RT		
7:00 AM	0	0	0	0	0	0	0	0	0	0	2	0	0	0	1	0	3	0
7:15 AM	0	0	0	0	0	0	0	0	0	0	2	0	0	0	1	0	3	0
7:30 AM	0	0	0	0	0	0	0	0	0	0	2	0	0	0	0	0	2	0
<b>7:45 AM</b>	<b>0</b>	<b>0</b>	<b>0</b>	<b>0</b>	<b>0</b>	<b>0</b>	<b>0</b>	<b>0</b>	<b>0</b>	<b>0</b>	<b>0</b>	<b>0</b>	<b>0</b>	<b>0</b>	<b>2</b>	<b>0</b>	<b>2</b>	<b>10</b>
8:00 AM	0	0	0	0	0	0	0	0	0	0	1	0	0	0	3	0	4	11
8:15 AM	0	0	0	0	0	0	0	0	0	0	0	0	0	0	4	0	4	12
8:30 AM	0	0	0	0	0	0	0	0	0	0	2	0	0	0	2	0	4	14
8:45 AM	0	0	0	0	0	0	0	0	0	0	2	0	0	0	2	0	4	16
Count Total	0	0	0	0	0	0	0	0	0	0	11	0	0	0	15	0	26	0
Peak Hour	0	0	0	0	0	0	0	0	0	0	3	0	0	0	11	0	14	0
<b>Two-Hour Count Summaries - Bikes</b>																		
Interval Start	Shiloh Neighborhood Church South				n/a				Old Redwood Hwy				Old Redwood Hwy				15-min Total	Rolling One Hour
	Eastbound				Westbound				Northbound				Southbound					
	LT	TH	RT		LT	TH	RT		LT	TH	RT		LT	TH	RT			
7:00 AM	0	0	0		0	0	0		0	1	0		0	0	0		1	0
7:15 AM	0	0	0		0	0	0		0	1	0		0	0	0		1	0
7:30 AM	0	0	0		0	0	0		0	0	0		0	0	0		0	0
<b>7:45 AM</b>	<b>0</b>	<b>0</b>	<b>0</b>		<b>0</b>	<b>0</b>	<b>0</b>		<b>0</b>	<b>0</b>	<b>0</b>		<b>0</b>	<b>0</b>	<b>0</b>		<b>0</b>	<b>2</b>
8:00 AM	0	0	0		0	0	0		0	0	0		0	1	0		1	2
8:15 AM	0	0	0		0	0	0		0	0	0		0	0	0		0	1
8:30 AM	0	0	0		0	0	0		0	1	0		0	1	0		2	3
8:45 AM	0	0	0		0	0	0		0	0	0		0	0	0		0	3
Count Total	0	0	0		0	0	0		0	3	0		0	2	0		5	0
Peak Hour	0	0	0		0	0	0		0	1	0		0	2	0		3	0
<i>Note: U-Turn volumes for bikes are included in Left-Turn, if any.</i>																		

# Driveway (East of Caporale Ct) Shiloh Rd



Peak Hour

Date: 07/28/2022  
Count Period: 7:00 AM to 9:00 AM  
Peak Hour: 7:30 AM to 8:30 AM

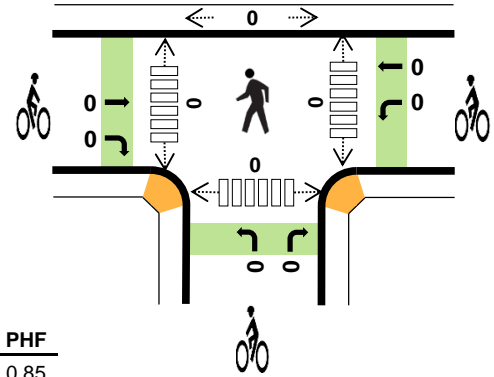
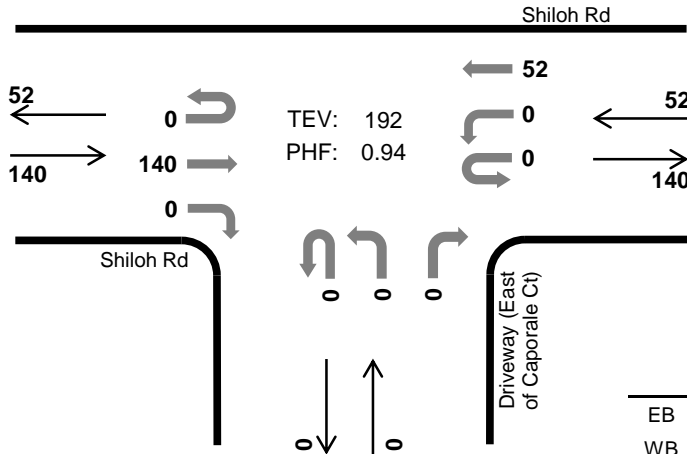

	HV %:	PHF
EB	2.1%	0.85
WB	3.8%	0.81
NB	-	-
SB	-	-
TOTAL	2.6%	0.94

## Two-Hour Count Summaries

Interval Start	Shiloh Rd Eastbound				Shiloh Rd Westbound				Driveway (East of Caporale Ct) Northbound				n/a Southbound				15-min Total	Rolling One Hour
	UT	LT	TH	RT	UT	LT	TH	RT	UT	LT	TH	RT	UT	LT	TH	RT		
7:00 AM	0	0	25	0	0	0	8	0	0	0	0	0	0	0	0	0	33	0
7:15 AM	0	0	29	0	0	0	10	0	0	0	0	0	0	0	0	0	39	0
7:30 AM	0	0	41	0	0	0	9	0	0	0	0	0	0	0	0	0	50	0
7:45 AM	0	0	37	0	0	0	14	0	0	0	0	0	0	0	0	0	51	173
8:00 AM	0	0	35	0	0	0	16	0	0	0	0	0	0	0	0	0	51	191
8:15 AM	0	0	27	0	0	0	13	0	0	0	0	0	0	0	0	0	40	192
8:30 AM	0	0	29	0	0	0	11	0	0	0	0	0	0	0	0	0	40	182
8:45 AM	0	0	32	2	0	0	16	0	0	0	0	0	0	0	0	0	50	181
Count Total	0	0	255	2	0	0	97	0	0	0	0	0	0	0	0	0	354	0
Peak Hour	All	0	0	140	0	0	0	52	0	0	0	0	0	0	0	0	192	0
	HV	0	0	3	0	0	0	2	0	0	0	0	0	0	0	0	5	0
	HV%	-	-	2%	-	-	-	4%	-	-	-	-	-	-	-	-	3%	0

Note: Two-hour count summary volumes include heavy vehicles but exclude bicycles in overall count.

Interval Start	Heavy Vehicle Totals					Bicycles					Pedestrians (Crossing Leg)				
	EB	WB	NB	SB	Total	EB	WB	NB	SB	Total	East	West	North	South	Total
7:00 AM	2	0	0	0	2	0	0	0	0	0	0	0	0	0	0
7:15 AM	0	0	0	0	0	1	0	0	0	1	0	0	0	1	1
7:30 AM	2	0	0	0	2	0	0	0	0	0	0	0	0	0	0
7:45 AM	1	1	0	0	2	0	0	0	0	0	0	0	0	0	0
8:00 AM	0	1	0	0	1	0	0	0	0	0	0	0	0	0	0
8:15 AM	0	0	0	0	0	0	0	0	0	0	0	0	0	0	0
8:30 AM	2	0	0	0	2	0	2	0	0	2	0	0	0	0	0
8:45 AM	3	0	0	0	3	0	1	0	0	1	0	0	2	0	2
Count Total	10	2	0	0	12	1	3	0	0	4	0	0	2	1	3
Peak Hr	3	2	0	0	5	0	0	0	0	0	0	0	0	0	0

**Two-Hour Count Summaries - Heavy Vehicles**

Interval Start	Shiloh Rd				Shiloh Rd				Driveway (East of Caporale Ct)				n/a				15-min Total	Rolling One Hour
	Eastbound				Westbound				Northbound				Southbound					
	UT	LT	TH	RT	UT	LT	TH	RT	UT	LT	TH	RT	UT	LT	TH	RT		
7:00 AM	0	0	2	0	0	0	0	0	0	0	0	0	0	0	0	0	2	0
7:15 AM	0	0	0	0	0	0	0	0	0	0	0	0	0	0	0	0	0	0
7:30 AM	0	0	2	0	0	0	0	0	0	0	0	0	0	0	0	0	2	0
7:45 AM	0	0	1	0	0	0	1	0	0	0	0	0	0	0	0	0	2	6
8:00 AM	0	0	0	0	0	0	1	0	0	0	0	0	0	0	0	0	1	5
8:15 AM	0	0	0	0	0	0	0	0	0	0	0	0	0	0	0	0	0	5
8:30 AM	0	0	2	0	0	0	0	0	0	0	0	0	0	0	0	0	2	5
8:45 AM	0	0	3	0	0	0	0	0	0	0	0	0	0	0	0	0	3	6
Count Total	0	0	10	0	0	0	2	0	0	0	0	0	0	0	0	0	12	0
Peak Hour	0	0	3	0	0	0	2	0	0	0	0	0	0	0	0	0	5	0

**Two-Hour Count Summaries - Bikes**

Interval Start	Shiloh Rd			Shiloh Rd			Driveway (East of Caporale Ct)			n/a			15-min Total	Rolling One Hour
	Eastbound			Westbound			Northbound			Southbound				
	LT	TH	RT	LT	TH	RT	LT	TH	RT	LT	TH	RT		
7:00 AM	0	0	0	0	0	0	0	0	0	0	0	0	0	0
7:15 AM	0	1	0	0	0	0	0	0	0	0	0	0	1	0
7:30 AM	0	0	0	0	0	0	0	0	0	0	0	0	0	0
7:45 AM	0	0	0	0	0	0	0	0	0	0	0	0	0	1
8:00 AM	0	0	0	0	0	0	0	0	0	0	0	0	0	1
8:15 AM	0	0	0	0	0	0	0	0	0	0	0	0	0	0
8:30 AM	0	0	0	0	2	0	0	0	0	0	0	0	2	2
8:45 AM	0	0	0	0	1	0	0	0	0	0	0	0	1	3
Count Total	0	1	0	0	3	0	0	0	0	0	0	0	4	0
Peak Hour	0	0	0	0	0	0	0	0	0	0	0	0	0	0

Note: U-Turn volumes for bikes are included in Left-Turn, if any.

# Lakewood Dr Old Redwood Hwy



Peak Hour

Date: 07/28/2022  
Count Period: 7:00 AM to 9:00 AM  
Peak Hour: 8:00 AM to 9:00 AM

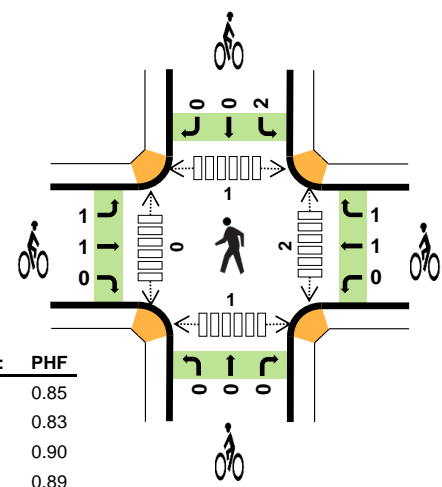
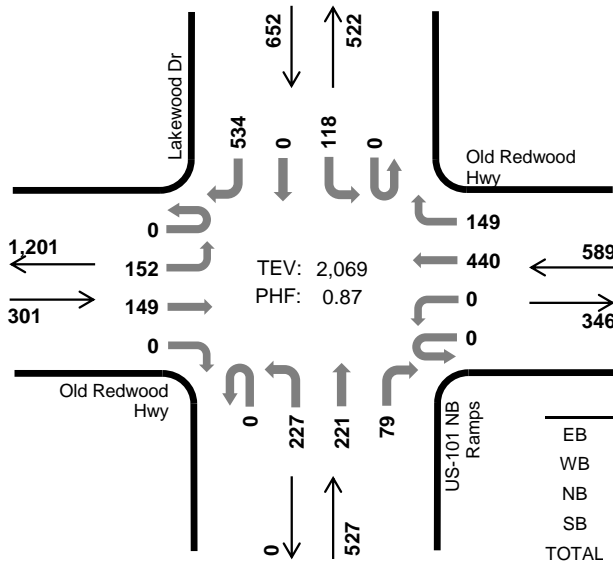

	HV %:	PHF
EB	4.3%	0.85
WB	1.9%	0.83
NB	2.5%	0.90
SB	1.1%	0.89
TOTAL	2.1%	0.87

### Two-Hour Count Summaries

Interval Start	Old Redwood Hwy Eastbound				Old Redwood Hwy Westbound				US-101 NB Ramps Northbound				Lakewood Dr Southbound				15-min Total	Rolling One Hour	
	UT	LT	TH	RT	UT	LT	TH	RT	UT	LT	TH	RT	UT	LT	TH	RT			
	7:00 AM	0	25	13	0	0	0	67	24	0	60	20	16	0	12	0			100
7:15 AM	0	16	23	0	0	0	75	18	0	39	36	20	0	17	0	91	335	0	
7:30 AM	0	18	29	0	0	0	110	28	0	43	50	15	0	16	0	116	425	0	
7:45 AM	0	28	36	0	0	0	108	36	0	51	61	27	0	21	0	119	487	1,584	
8:00 AM	0	28	27	0	0	0	98	37	0	49	57	22	0	19	0	141	478	1,725	
8:15 AM	0	42	37	0	0	0	97	32	0	53	59	17	0	30	0	113	480	1,870	
8:30 AM	0	37	41	0	0	0	121	26	0	57	50	17	0	32	0	134	515	1,960	
8:45 AM	0	45	44	0	0	0	124	54	0	68	55	23	0	37	0	146	596	2,069	
Count Total	0	239	250	0	0	0	800	255	0	420	388	157	0	184	0	960	3,653	0	
Peak Hour	All	0	152	149	0	0	0	440	149	0	227	221	79	0	118	0	534	2,069	0
	HV	0	1	12	0	0	0	8	3	0	6	4	3	0	1	0	6	44	0
	HV%	-	1%	8%	-	-	-	2%	2%	-	3%	2%	4%	-	1%	-	1%	2%	0

Note: Two-hour count summary volumes include heavy vehicles but exclude bicycles in overall count.

Interval Start	Heavy Vehicle Totals					Bicycles					Pedestrians (Crossing Leg)				
	EB	WB	NB	SB	Total	EB	WB	NB	SB	Total	East	West	North	South	Total
7:00 AM	0	2	5	3	10	0	1	0	0	1	2	0	1	2	5
7:15 AM	3	1	5	0	9	1	0	0	0	1	0	0	1	0	1
7:30 AM	2	0	1	2	5	0	0	0	0	0	2	0	2	1	5
7:45 AM	1	3	5	1	10	1	2	0	0	3	0	0	1	0	1
8:00 AM	2	2	6	3	13	1	1	0	0	2	0	0	0	0	0
8:15 AM	5	3	3	2	13	1	0	0	1	2	0	0	0	1	1
8:30 AM	4	2	1	1	8	0	0	0	0	0	2	0	1	0	3
8:45 AM	2	4	3	1	10	0	1	0	1	2	0	0	0	0	0
Count Total	19	17	29	13	78	4	5	0	2	11	6	0	6	4	16
Peak Hour	13	11	13	7	44	2	2	0	2	6	2	0	1	1	4

<b>Two-Hour Count Summaries - Heavy Vehicles</b>																		
Interval Start	Old Redwood Hwy				Old Redwood Hwy				US-101 NB Ramps				Lakewood Dr				15-min Total	Rolling One Hour
	Eastbound				Westbound				Northbound				Southbound					
	UT	LT	TH	RT	UT	LT	TH	RT	UT	LT	TH	RT	UT	LT	TH	RT		
7:00 AM	0	0	0	0	0	0	1	1	0	4	1	0	0	0	0	3	10	0
7:15 AM	0	0	3	0	0	0	1	0	0	3	1	1	0	0	0	0	9	0
7:30 AM	0	1	1	0	0	0	0	0	0	1	0	0	0	0	0	2	5	0
7:45 AM	0	0	1	0	0	0	3	0	0	1	2	2	0	0	0	1	10	34
8:00 AM	0	0	2	0	0	0	1	1	0	2	1	3	0	1	0	2	13	37
8:15 AM	0	0	5	0	0	0	3	0	0	1	2	0	0	0	0	2	13	41
8:30 AM	0	1	3	0	0	0	1	1	0	1	0	0	0	0	0	1	8	44
8:45 AM	0	0	2	0	0	0	3	1	0	2	1	0	0	0	0	1	10	44
Count Total	0	2	17	0	0	0	13	4	0	15	8	6	0	1	0	12	78	0
Peak Hour	0	1	12	0	0	0	8	3	0	6	4	3	0	1	0	6	44	0
<b>Two-Hour Count Summaries - Bikes</b>																		
Interval Start	Old Redwood Hwy			Old Redwood Hwy			US-101 NB Ramps			Lakewood Dr			15-min Total	Rolling One Hour				
	Eastbound			Westbound			Northbound			Southbound								
	LT	TH	RT	LT	TH	RT	LT	TH	RT	LT	TH	RT						
7:00 AM	0	0	0	0	1	0	0	0	0	0	0	0	0	0	0	1	0	
7:15 AM	0	1	0	0	0	0	0	0	0	0	0	0	0	0	0	1	0	
7:30 AM	0	0	0	0	0	0	0	0	0	0	0	0	0	0	0	0	0	
7:45 AM	0	1	0	0	2	0	0	0	0	0	0	0	0	0	0	3	5	
8:00 AM	0	1	0	0	0	1	0	0	0	0	0	0	0	0	0	2	6	
8:15 AM	1	0	0	0	0	0	0	0	0	0	0	0	1	0	0	2	7	
8:30 AM	0	0	0	0	0	0	0	0	0	0	0	0	0	0	0	0	7	
8:45 AM	0	0	0	0	1	0	0	0	0	0	0	0	1	0	0	2	6	
Count Total	1	3	0	0	4	1	0	0	0	0	0	0	2	0	0	11	0	
Peak Hour	1	1	0	0	1	1	0	0	0	0	0	0	2	0	0	6	0	
<i>Note: U-Turn volumes for bikes are included in Left-Turn, if any.</i>																		

# US-101 NB On-Ramp Old Redwood Hwy



Date: 07/28/2022

Count Period: 7:00 AM to 9:00 AM

Peak Hour: 8:00 AM to 9:00 AM

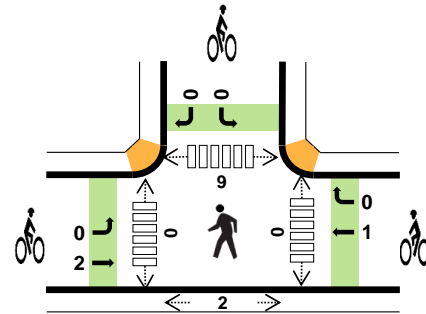
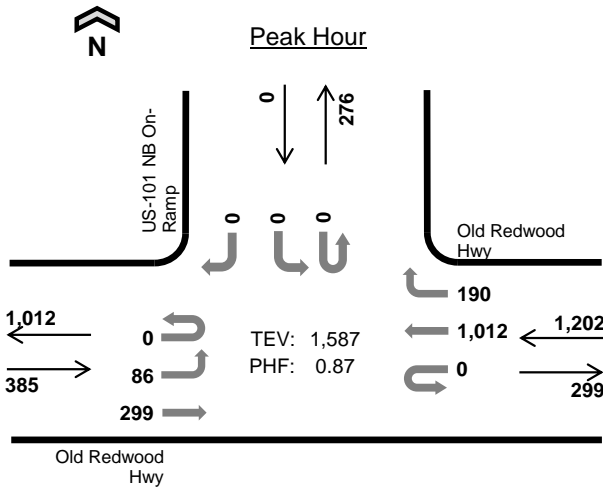

	HV %:	PHF
EB	4.4%	0.81
WB	2.1%	0.89
NB	-	-
SB	-	-
TOTAL	2.6%	0.87

## Two-Hour Count Summaries

Interval Start	Old Redwood Hwy Eastbound				Old Redwood Hwy Westbound				N/A Northbound				US-101 NB On-Ramp Southbound				15-min Total	Rolling One Hour	
	UT	LT	TH	RT	UT	LT	TH	RT	UT	LT	TH	RT	UT	LT	TH	RT			
7:00 AM	0	16	37	0	0	0	190	35	0	0	0	0	0	0	0	0	278	0	
7:15 AM	0	26	41	0	0	0	182	20	0	0	0	0	0	0	0	0	269	0	
7:30 AM	0	15	47	0	0	0	230	39	0	0	0	0	0	0	0	0	331	0	
7:45 AM	0	21	68	0	0	0	247	34	0	0	0	0	0	0	0	0	370	1,248	
8:00 AM	0	21	62	0	0	0	240	46	0	0	0	0	0	0	0	0	369	1,339	
8:15 AM	0	19	66	0	0	0	231	33	0	0	0	0	0	0	0	0	349	1,419	
8:30 AM	0	20	78	0	0	0	265	49	0	0	0	0	0	0	0	0	412	1,500	
8:45 AM	0	26	93	0	0	0	276	62	0	0	0	0	0	0	0	0	457	1,587	
Count Total	0	164	492	0	0	0	1,861	318	0	0	0	0	0	0	0	0	2,835	0	
Peak Hour	All	0	86	299	0	0	0	1,012	190	0	0	0	0	0	0	0	0	1,587	0
	HV	0	5	12	0	0	0	19	6	0	0	0	0	0	0	0	0	42	0
	HV%	-	6%	4%	-	-	-	2%	3%	-	-	-	-	-	-	-	-	3%	0

Note: Two-hour count summary volumes include heavy vehicles but exclude bicycles in overall count.

Interval Start	Heavy Vehicle Totals					Bicycles					Pedestrians (Crossing Leg)				
	EB	WB	NB	SB	Total	EB	WB	NB	SB	Total	East	West	North	South	Total
7:00 AM	1	10	0	0	11	0	1	0	0	1	0	0	0	1	1
7:15 AM	4	4	0	0	8	0	1	0	0	1	0	0	1	0	1
7:30 AM	2	5	0	0	7	0	0	0	0	0	0	0	2	1	3
7:45 AM	2	6	0	0	8	1	3	0	0	4	0	0	2	0	2
8:00 AM	4	6	0	0	10	0	0	0	0	0	0	0	1	0	1
8:15 AM	5	6	0	0	11	2	0	0	0	2	0	0	2	1	3
8:30 AM	5	5	0	0	10	0	0	0	0	0	0	0	3	1	4
8:45 AM	3	8	0	0	11	0	1	0	0	1	0	0	3	0	3
Count Total	26	50	0	0	76	3	6	0	0	9	0	0	14	4	18
Peak Hr	17	25	0	0	42	2	1	0	0	3	0	0	9	2	11

<b>Two-Hour Count Summaries - Heavy Vehicles</b>																		
Interval Start	Old Redwood Hwy				Old Redwood Hwy				N/A				US-101 NB On-Ramp				15-min Total	Rolling One Hour
	Eastbound				Westbound				Northbound				Southbound					
	UT	LT	TH	RT	UT	LT	TH	RT	UT	LT	TH	RT	UT	LT	TH	RT		
7:00 AM	0	1	0	0	0	0	6	4	0	0	0	0	0	0	0	0	11	0
7:15 AM	0	1	3	0	0	0	3	1	0	0	0	0	0	0	0	0	8	0
7:30 AM	0	0	2	0	0	0	4	1	0	0	0	0	0	0	0	0	7	0
7:45 AM	0	1	1	0	0	0	6	0	0	0	0	0	0	0	0	0	8	34
8:00 AM	0	3	1	0	0	0	4	2	0	0	0	0	0	0	0	0	10	33
8:15 AM	0	0	5	0	0	0	6	0	0	0	0	0	0	0	0	0	11	36
8:30 AM	0	1	4	0	0	0	4	1	0	0	0	0	0	0	0	0	10	39
8:45 AM	0	1	2	0	0	0	5	3	0	0	0	0	0	0	0	0	11	42
Count Total	0	8	18	0	0	0	38	12	0	0	0	0	0	0	0	0	76	0
Peak Hour	0	5	12	0	0	0	19	6	0	0	0	0	0	0	0	0	42	0
<b>Two-Hour Count Summaries - Bikes</b>																		
Interval Start	Old Redwood Hwy			Old Redwood Hwy			N/A			US-101 NB On-Ramp			15-min Total	Rolling One Hour				
	Eastbound			Westbound			Northbound			Southbound								
	LT	TH	RT	LT	TH	RT	LT	TH	RT	LT	TH	RT						
7:00 AM	0	0	0	0	1	0	0	0	0	0	0	0	0	0	0	1	0	
7:15 AM	0	0	0	0	1	0	0	0	0	0	0	0	0	0	0	1	0	
7:30 AM	0	0	0	0	0	0	0	0	0	0	0	0	0	0	0	0	0	
7:45 AM	0	1	0	0	3	0	0	0	0	0	0	0	0	0	0	4	6	
8:00 AM	0	0	0	0	0	0	0	0	0	0	0	0	0	0	0	0	5	
8:15 AM	0	2	0	0	0	0	0	0	0	0	0	0	0	0	0	2	6	
8:30 AM	0	0	0	0	0	0	0	0	0	0	0	0	0	0	0	0	6	
8:45 AM	0	0	0	0	1	0	0	0	0	0	0	0	0	0	0	1	3	
Count Total	0	3	0	0	6	0	0	0	0	0	0	0	0	0	0	9	0	
Peak Hour	0	2	0	0	1	0	0	0	0	0	0	0	0	0	0	3	0	
<i>Note: U-Turn volumes for bikes are included in Left-Turn, if any.</i>																		



# US-101 SB Ramps Old Redwood Hwy



Peak Hour

Date: 07/28/2022

Count Period: 7:00 AM to 9:00 AM

Peak Hour: 8:00 AM to 9:00 AM

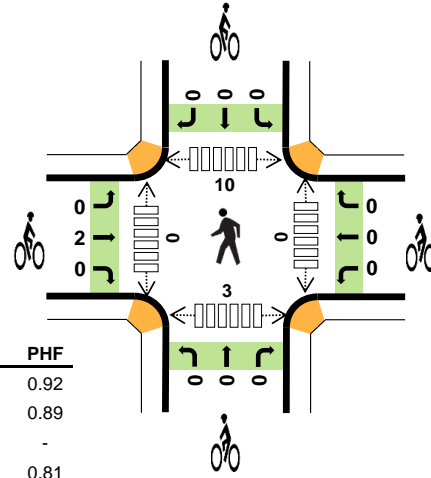
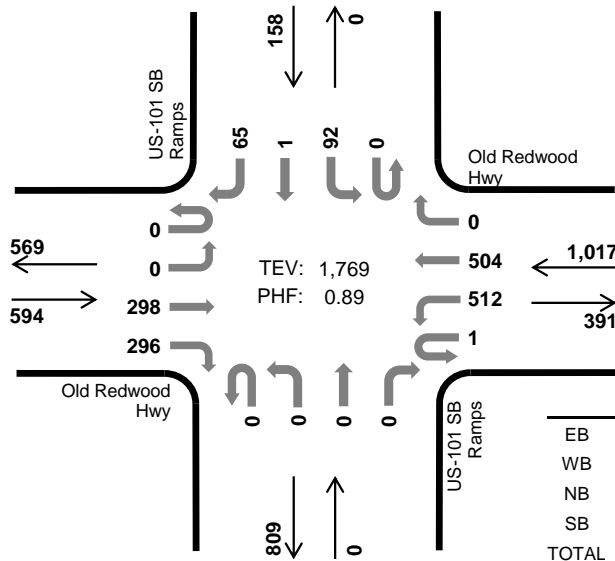

	HV %:	PHF
EB	3.4%	0.92
WB	1.8%	0.89
NB	-	-
SB	3.8%	0.81
TOTAL	2.5%	0.89

### Two-Hour Count Summaries

Interval Start	Old Redwood Hwy Eastbound				Old Redwood Hwy Westbound				US-101 SB Ramps Northbound				US-101 SB Ramps Southbound				15-min Total	Rolling One Hour	
	UT	LT	TH	RT	UT	LT	TH	RT	UT	LT	TH	RT	UT	LT	TH	RT			
	7:00 AM	0	0	47	51	0	96	98	0	0	0	0	0	0	4	0			9
7:15 AM	0	0	53	54	0	99	85	0	0	0	0	0	0	9	0	12	312	0	
7:30 AM	0	0	47	112	0	145	82	0	0	0	0	0	0	18	0	6	410	0	
7:45 AM	0	0	63	67	0	133	107	0	0	0	0	0	0	24	0	18	412	1,439	
<b>8:00 AM</b>	<b>0</b>	<b>0</b>	<b>75</b>	<b>71</b>	<b>0</b>	<b>135</b>	<b>106</b>	<b>0</b>	<b>0</b>	<b>0</b>	<b>0</b>	<b>0</b>	<b>0</b>	<b>12</b>	<b>0</b>	<b>18</b>	<b>417</b>	<b>1,551</b>	
8:15 AM	0	0	62	72	1	124	108	0	0	0	0	0	0	20	1	12	400	1,639	
8:30 AM	0	0	71	81	0	124	132	0	0	0	0	0	0	31	0	15	454	1,683	
<b>8:45 AM</b>	<b>0</b>	<b>0</b>	<b>90</b>	<b>72</b>	<b>0</b>	<b>129</b>	<b>158</b>	<b>0</b>	<b>0</b>	<b>0</b>	<b>0</b>	<b>0</b>	<b>0</b>	<b>29</b>	<b>0</b>	<b>20</b>	<b>498</b>	<b>1,769</b>	
Count Total	0	0	508	580	1	985	876	0	0	0	0	0	0	147	1	110	3,208	0	
Peak Hour	All	0	0	298	296	1	512	504	0	0	0	0	0	0	92	1	65	1,769	0
	HV	0	0	13	7	0	4	14	0	0	0	0	0	0	3	1	2	44	0
	HV%	-	-	4%	2%	0%	1%	3%	-	-	-	-	-	-	3%	100%	3%	2%	0

Note: Two-hour count summary volumes include heavy vehicles but exclude bicycles in overall count.

Interval Start	Heavy Vehicle Totals					Bicycles					Pedestrians (Crossing Leg)				
	EB	WB	NB	SB	Total	EB	WB	NB	SB	Total	East	West	North	South	Total
7:00 AM	2	6	0	0	8	0	0	0	0	0	0	0	1	2	3
7:15 AM	4	4	0	1	9	1	1	0	0	2	0	0	2	0	2
7:30 AM	5	4	0	0	9	0	0	0	0	0	0	0	2	1	3
7:45 AM	3	5	0	0	8	1	3	0	0	4	0	0	1	0	1
<b>8:00 AM</b>	<b>5</b>	<b>4</b>	<b>0</b>	<b>1</b>	<b>10</b>	<b>0</b>	<b>0</b>	<b>0</b>	<b>0</b>	<b>0</b>	<b>0</b>	<b>0</b>	<b>3</b>	<b>0</b>	<b>3</b>
8:15 AM	10	6	0	3	19	2	0	0	0	2	0	0	2	1	3
8:30 AM	2	4	0	1	7	0	0	0	0	0	0	0	3	2	5
<b>8:45 AM</b>	<b>3</b>	<b>4</b>	<b>0</b>	<b>1</b>	<b>8</b>	<b>0</b>	<b>0</b>	<b>0</b>	<b>0</b>	<b>0</b>	<b>0</b>	<b>0</b>	<b>2</b>	<b>0</b>	<b>2</b>
Count Total	34	37	0	7	78	4	4	0	0	8	0	0	16	6	22
Peak Hour	20	18	0	6	44	2	0	0	0	2	0	0	10	3	13

<b>Two-Hour Count Summaries - Heavy Vehicles</b>																		
Interval Start	Old Redwood Hwy				Old Redwood Hwy				US-101 SB Ramps				US-101 SB Ramps				15-min Total	Rolling One Hour
	Eastbound				Westbound				Northbound				Southbound					
	UT	LT	TH	RT	UT	LT	TH	RT	UT	LT	TH	RT	UT	LT	TH	RT		
7:00 AM	0	0	1	1	0	1	5	0	0	0	0	0	0	0	0	8	0	
7:15 AM	0	0	2	2	0	1	3	0	0	0	0	0	0	1	0	9	0	
7:30 AM	0	0	1	4	0	1	3	0	0	0	0	0	0	0	0	9	0	
7:45 AM	0	0	1	2	0	3	2	0	0	0	0	0	0	0	0	8	34	
8:00 AM	0	0	3	2	0	1	3	0	0	0	0	0	0	0	1	10	36	
8:15 AM	0	0	6	4	0	2	4	0	0	0	0	0	0	1	1	19	46	
8:30 AM	0	0	2	0	0	1	3	0	0	0	0	0	0	1	0	7	44	
8:45 AM	0	0	2	1	0	0	4	0	0	0	0	0	0	1	0	8	44	
Count Total	0	0	18	16	0	10	27	0	0	0	0	0	4	1	2	78	0	
Peak Hour	0	0	13	7	0	4	14	0	0	0	0	0	3	1	2	44	0	
<b>Two-Hour Count Summaries - Bikes</b>																		
Interval Start	Old Redwood Hwy			Old Redwood Hwy			US-101 SB Ramps			US-101 SB Ramps			15-min Total	Rolling One Hour				
	Eastbound			Westbound			Northbound			Southbound								
	LT	TH	RT	LT	TH	RT	LT	TH	RT	LT	TH	RT						
7:00 AM	0	0	0	0	0	0	0	0	0	0	0	0	0	0	0	0		
7:15 AM	0	1	0	0	1	0	0	0	0	0	0	0	0	0	2	0		
7:30 AM	0	0	0	0	0	0	0	0	0	0	0	0	0	0	0	0		
7:45 AM	0	1	0	0	3	0	0	0	0	0	0	0	0	0	4	6		
8:00 AM	0	0	0	0	0	0	0	0	0	0	0	0	0	0	0	6		
8:15 AM	0	2	0	0	0	0	0	0	0	0	0	0	0	0	2	6		
8:30 AM	0	0	0	0	0	0	0	0	0	0	0	0	0	0	0	6		
8:45 AM	0	0	0	0	0	0	0	0	0	0	0	0	0	0	0	2		
Count Total	0	4	0	0	4	0	0	0	0	0	0	0	0	0	8	0		
Peak Hour	0	2	0	0	0	0	0	0	0	0	0	0	0	0	2	0		
<i>Note: U-Turn volumes for bikes are included in Left-Turn, if any.</i>																		

## Old Redwood Hwy Shiloh Rd



Peak Hour

Date: 07/28/2022  
Count Period: 4:00 PM to 6:00 PM  
Peak Hour: 4:30 PM to 5:30 PM

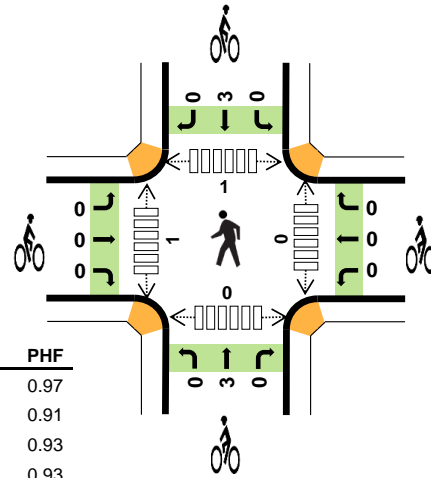
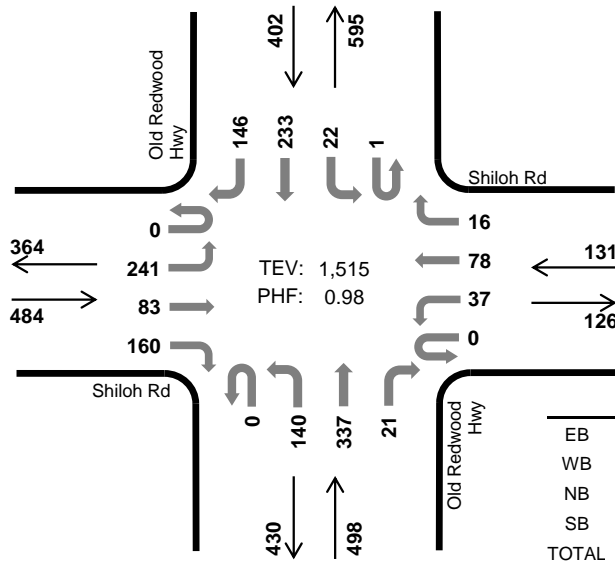

	HV %:	PHF
EB	1.2%	0.97
WB	0.8%	0.91
NB	0.4%	0.93
SB	1.0%	0.93
TOTAL	0.9%	0.98

### Two-Hour Count Summaries

Interval Start	Shiloh Rd Eastbound				Shiloh Rd Westbound				Old Redwood Hwy Northbound				Old Redwood Hwy Southbound				15-min Total	Rolling One Hour	
	UT	LT	TH	RT	UT	LT	TH	RT	UT	LT	TH	RT	UT	LT	TH	RT			
4:00 PM	0	59	17	47	0	10	40	4	0	24	68	5	0	9	53	38	374	0	
4:15 PM	0	59	18	46	0	6	21	3	0	27	76	8	0	4	65	35	368	0	
4:30 PM	0	61	22	33	0	13	20	3	0	47	84	3	0	6	55	41	388	0	
4:45 PM	0	52	21	52	0	9	20	4	0	31	86	7	0	6	48	32	368	1,498	
5:00 PM	0	70	16	38	0	6	20	4	0	33	81	3	0	7	64	35	377	1,501	
5:15 PM	0	58	24	37	0	9	18	5	0	29	86	8	1	3	66	38	382	1,515	
5:30 PM	0	39	20	32	0	4	19	5	0	46	72	6	0	6	57	32	338	1,465	
5:45 PM	0	37	15	25	0	2	19	4	0	40	76	4	0	2	57	36	317	1,414	
Count Total	0	435	153	310	0	59	177	32	0	277	629	44	1	43	465	287	2,912	0	
Peak Hour	All	0	241	83	160	0	37	78	16	0	140	337	21	1	22	233	146	1,515	0
	HV	0	3	2	1	0	0	1	0	0	1	1	0	0	0	0	4	13	0
	HV%	-	1%	2%	1%	-	0%	1%	0%	-	1%	0%	0%	0%	0%	0%	3%	1%	0

Note: Two-hour count summary volumes include heavy vehicles but exclude bicycles in overall count.

Interval Start	Heavy Vehicle Totals					Bicycles					Pedestrians (Crossing Leg)				
	EB	WB	NB	SB	Total	EB	WB	NB	SB	Total	East	West	North	South	Total
4:00 PM	1	5	1	2	9	1	0	0	0	1	0	0	1	0	1
4:15 PM	1	0	1	1	3	0	0	0	0	0	0	0	0	0	0
4:30 PM	1	1	0	0	2	0	0	0	1	1	0	1	0	0	1
4:45 PM	2	0	1	2	5	0	0	0	0	0	0	0	1	0	1
5:00 PM	2	0	1	1	4	0	0	1	2	3	0	0	0	0	0
5:15 PM	1	0	0	1	2	0	0	2	0	2	0	0	0	0	0
5:30 PM	1	0	0	1	2	0	0	0	0	0	0	0	0	0	0
5:45 PM	0	0	1	1	2	0	0	2	0	2	0	0	0	0	0
Count Total	9	6	5	9	29	1	0	5	3	9	0	1	2	0	3
Peak Hour	6	1	2	4	13	0	0	3	3	6	0	1	1	0	2

<b>Two-Hour Count Summaries - Heavy Vehicles</b>																				
Interval Start	Shiloh Rd				Shiloh Rd				Old Redwood Hwy				Old Redwood Hwy				15-min Total	Rolling One Hour		
	Eastbound				Westbound				Northbound				Southbound							
	UT	LT	TH	RT	UT	LT	TH	RT	UT	LT	TH	RT	UT	LT	TH	RT				
4:00 PM	0	1	0	0	0	1	4	0	0	1	0	0	0	0	0	0	2	9	0	
4:15 PM	0	0	0	1	0	0	0	0	0	0	0	1	0	0	0	0	1	0	3	0
<b>4:30 PM</b>	<b>0</b>	<b>1</b>	<b>0</b>	<b>0</b>	<b>0</b>	<b>0</b>	<b>1</b>	<b>0</b>	<b>0</b>	<b>0</b>	<b>0</b>	<b>0</b>	<b>0</b>	<b>0</b>	<b>0</b>	<b>0</b>	<b>0</b>	<b>2</b>	<b>0</b>	
4:45 PM	0	0	1	1	0	0	0	0	0	0	1	0	0	0	0	0	0	2	5	19
5:00 PM	0	1	1	0	0	0	0	0	0	0	0	1	0	0	0	0	0	1	4	14
5:15 PM	0	1	0	0	0	0	0	0	0	0	0	0	0	0	0	0	0	1	2	13
5:30 PM	0	0	0	1	0	0	0	0	0	0	0	0	0	0	0	0	0	1	2	13
5:45 PM	0	0	0	0	0	0	0	0	0	0	1	0	0	0	0	0	0	1	2	10
Count Total	0	4	2	3	0	1	5	0	0	3	2	0	0	0	0	1	8	29	0	
Peak Hour	0	3	2	1	0	0	1	0	0	1	1	0	0	0	0	0	4	13	0	

<b>Two-Hour Count Summaries - Bikes</b>																				
Interval Start	Shiloh Rd			Shiloh Rd			Old Redwood Hwy			Old Redwood Hwy			15-min Total	Rolling One Hour						
	Eastbound			Westbound			Northbound			Southbound										
	LT	TH	RT	LT	TH	RT	LT	TH	RT	LT	TH	RT								
4:00 PM	0	0	1	0	0	0	0	0	0	0	0	0	0	0	0	0	0	1	0	
4:15 PM	0	0	0	0	0	0	0	0	0	0	0	0	0	0	0	0	0	0	0	0
<b>4:30 PM</b>	<b>0</b>	<b>0</b>	<b>0</b>	<b>0</b>	<b>0</b>	<b>0</b>	<b>0</b>	<b>0</b>	<b>0</b>	<b>0</b>	<b>0</b>	<b>0</b>	<b>0</b>	<b>1</b>	<b>0</b>	<b>0</b>	<b>1</b>	<b>0</b>	<b>0</b>	
4:45 PM	0	0	0	0	0	0	0	0	0	0	0	0	0	0	0	0	0	0	0	2
5:00 PM	0	0	0	0	0	0	0	0	0	1	0	0	0	2	0	0	0	3	4	4
5:15 PM	0	0	0	0	0	0	0	0	0	2	0	0	0	0	0	0	0	2	6	6
5:30 PM	0	0	0	0	0	0	0	0	0	0	0	0	0	0	0	0	0	0	5	5
5:45 PM	0	0	0	0	0	0	0	0	1	1	0	0	0	0	0	0	0	2	7	7
Count Total	0	0	1	0	0	0	0	1	4	0	0	3	0	0	3	0	9	0	0	0
Peak Hour	0	0	0	0	0	0	0	0	3	0	0	3	0	0	3	0	6	0	0	0

Note: U-Turn volumes for bikes are included in Left-Turn, if any.

### Hembree Ln Shiloh Rd

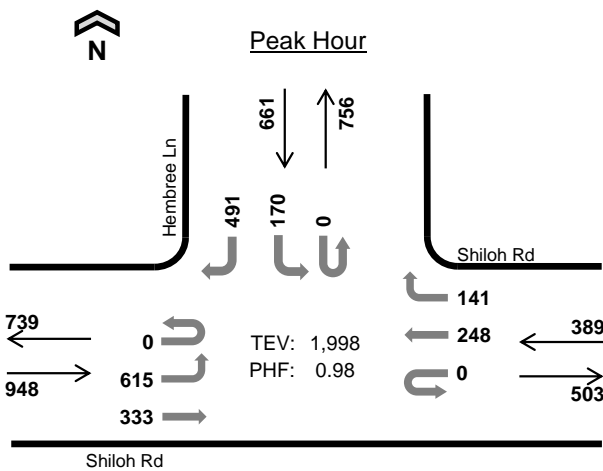

Date: 07/28/2022  
 Count Period: 4:00 PM to 6:00 PM  
 Peak Hour: 4:30 PM to 5:30 PM

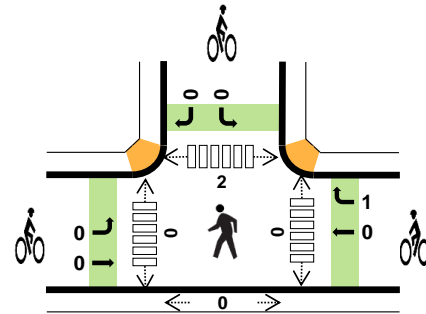

	HV %:	PHF
EB	1.6%	0.94
WB	2.3%	0.87
NB	-	-
SB	2.0%	0.95
TOTAL	1.9%	0.98

#### Two-Hour Count Summaries

Interval Start	Shiloh Rd Eastbound				Shiloh Rd Westbound				n/a Northbound				Hembree Ln Southbound				15-min Total	Rolling One Hour	
	UT	LT	TH	RT	UT	LT	TH	RT	UT	LT	TH	RT	UT	LT	TH	RT			
4:00 PM	0	139	91	0	0	0	74	25	0	0	0	0	0	38	0	115	482	0	
4:15 PM	0	130	82	0	0	0	59	35	0	0	0	0	0	42	0	120	468	0	
<b>4:30 PM</b>	<b>0</b>	<b>153</b>	<b>81</b>	<b>0</b>	<b>0</b>	<b>0</b>	<b>63</b>	<b>49</b>	<b>0</b>	<b>0</b>	<b>0</b>	<b>0</b>	<b>0</b>	<b>42</b>	<b>0</b>	<b>124</b>	<b>512</b>	<b>0</b>	
4:45 PM	0	139	86	0	0	0	51	36	0	0	0	0	0	45	0	129	486	1,948	
5:00 PM	0	165	86	0	0	0	67	28	0	0	0	0	0	36	0	112	494	1,960	
5:15 PM	0	158	80	0	0	0	67	28	0	0	0	0	0	47	0	126	506	1,998	
5:30 PM	0	119	66	0	0	0	60	31	0	0	0	0	0	30	0	112	418	1,904	
5:45 PM	0	117	56	0	0	0	70	40	0	0	0	0	0	24	0	94	401	1,819	
Count Total	0	1,120	628	0	0	0	511	272	0	0	0	0	0	304	0	932	3,767	0	
Peak Hour	All	0	615	333	0	0	0	248	141	0	0	0	0	0	170	0	491	1,998	0
	HV	0	7	8	0	0	0	6	3	0	0	0	0	0	4	0	9	37	0
	HV%	-	1%	2%	-	-	-	2%	2%	-	-	-	-	-	2%	-	2%	2%	0

Note: Two-hour count summary volumes include heavy vehicles but exclude bicycles in overall count.

Interval Start	Heavy Vehicle Totals					Bicycles					Pedestrians (Crossing Leg)				
	EB	WB	NB	SB	Total	EB	WB	NB	SB	Total	East	West	North	South	Total
4:00 PM	5	6	0	2	13	0	0	0	0	0	0	0	1	0	1
4:15 PM	2	2	0	6	10	0	0	0	0	0	0	0	1	0	1
<b>4:30 PM</b>	<b>7</b>	<b>2</b>	<b>0</b>	<b>4</b>	<b>13</b>	<b>0</b>	<b>0</b>	<b>0</b>	<b>0</b>	<b>0</b>	<b>0</b>	<b>0</b>	<b>0</b>	<b>0</b>	<b>0</b>
4:45 PM	3	4	0	3	10	0	1	0	0	1	0	0	0	0	0
5:00 PM	2	2	0	3	7	0	0	0	0	0	0	0	2	0	2
5:15 PM	3	1	0	3	7	0	0	0	0	0	0	0	0	0	0
5:30 PM	3	1	0	2	6	0	0	0	0	0	0	0	0	0	0
5:45 PM	0	3	0	4	7	0	1	0	0	1	0	0	0	0	0
Count Total	25	21	0	27	73	0	2	0	0	2	0	0	4	0	4
Peak Hr	15	9	0	13	37	0	1	0	0	1	0	0	2	0	2

Two-Hour Count Summaries - Heavy Vehicles														15-min Total	Rolling One Hour			
Interval Start	Shiloh Rd				Shiloh Rd				n/a				Hembree Ln					
	Eastbound				Westbound				Northbound				Southbound					
	UT	LT	TH	RT	UT	LT	TH	RT	UT	LT	TH	RT	UT	LT	TH	RT		
4:00 PM	0	1	4	0	0	0	5	1	0	0	0	0	0	1	0	1	13	0
4:15 PM	0	0	2	0	0	0	0	2	0	0	0	0	0	1	0	5	10	0
<b>4:30 PM</b>	<b>0</b>	<b>5</b>	<b>2</b>	<b>0</b>	<b>0</b>	<b>0</b>	<b>2</b>	<b>0</b>	<b>0</b>	<b>0</b>	<b>0</b>	<b>0</b>	<b>0</b>	<b>1</b>	<b>0</b>	<b>3</b>	<b>13</b>	<b>0</b>
4:45 PM	0	0	3	0	0	0	3	1	0	0	0	0	0	1	0	2	10	46
5:00 PM	0	1	1	0	0	0	1	1	0	0	0	0	0	1	0	2	7	40
5:15 PM	0	1	2	0	0	0	0	1	0	0	0	0	0	1	0	2	7	37
5:30 PM	0	3	0	0	0	0	0	1	0	0	0	0	0	1	0	1	6	30
5:45 PM	0	0	0	0	0	0	2	1	0	0	0	0	0	2	0	2	7	27
Count Total	0	11	14	0	0	0	13	8	0	0	0	0	0	9	0	18	73	0
Peak Hour	0	7	8	0	0	0	6	3	0	0	0	0	0	4	0	9	37	0

Two-Hour Count Summaries - Bikes														15-min Total	Rolling One Hour			
Interval Start	Shiloh Rd			Shiloh Rd			n/a			Hembree Ln								
	Eastbound			Westbound			Northbound			Southbound								
	LT	TH	RT	LT	TH	RT	LT	TH	RT	LT	TH	RT	LT	TH	RT			
4:00 PM	0	0	0	0	0	0	0	0	0	0	0	0	0	0	0	0	0	0
4:15 PM	0	0	0	0	0	0	0	0	0	0	0	0	0	0	0	0	0	0
<b>4:30 PM</b>	<b>0</b>	<b>0</b>	<b>0</b>	<b>0</b>	<b>0</b>	<b>0</b>	<b>0</b>	<b>0</b>	<b>0</b>	<b>0</b>	<b>0</b>	<b>0</b>	<b>0</b>	<b>0</b>	<b>0</b>	<b>0</b>	<b>0</b>	<b>0</b>
4:45 PM	0	0	0	0	0	1	0	0	0	0	0	0	0	0	0	0	1	1
5:00 PM	0	0	0	0	0	0	0	0	0	0	0	0	0	0	0	0	0	1
5:15 PM	0	0	0	0	0	0	0	0	0	0	0	0	0	0	0	0	0	1
5:30 PM	0	0	0	0	0	0	0	0	0	0	0	0	0	0	0	0	0	1
5:45 PM	0	0	0	0	0	1	0	0	0	0	0	0	0	0	0	0	1	1
Count Total	0	0	0	0	0	2	0	0	0	0	0	0	0	0	0	0	2	0
Peak Hour	0	0	0	0	0	1	0	0	0	0	0	0	0	0	0	0	1	0

Note: U-Turn volumes for bikes are included in Left-Turn, if any.

### US-101 NB Ramps Shiloh Rd



Date: 07/28/2022  
 Count Period: 4:00 PM to 6:00 PM  
 Peak Hour: 4:30 PM to 5:30 PM

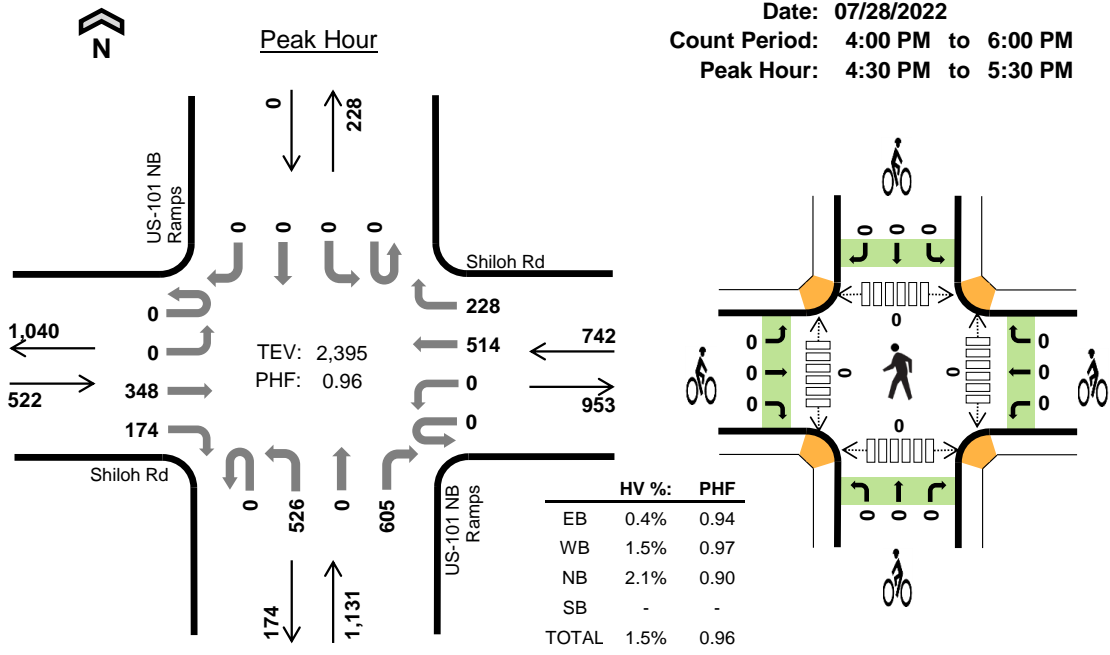

#### Two-Hour Count Summaries

Interval Start	Shiloh Rd Eastbound				Shiloh Rd Westbound				US-101 NB Ramps Northbound				US-101 NB Ramps Southbound				15-min Total	Rolling One Hour	
	UT	LT	TH	RT	UT	LT	TH	RT	UT	LT	TH	RT	UT	LT	TH	RT			
4:00 PM	1	1	93	41	0	0	136	51	0	114	0	119	0	0	0	0	556	0	
4:15 PM	0	0	96	31	0	0	137	51	0	99	0	126	0	0	0	0	540	0	
4:30 PM	0	0	97	42	0	0	130	55	0	121	0	140	0	0	0	0	585	0	
4:45 PM	0	0	84	47	0	0	129	54	0	112	0	151	0	0	0	0	577	2,258	
5:00 PM	0	0	89	47	0	0	121	61	0	135	0	157	0	0	0	0	610	2,312	
5:15 PM	0	0	78	38	0	0	134	58	0	158	0	157	0	0	0	0	623	2,395	
5:30 PM	0	0	75	28	0	0	136	40	0	117	0	103	0	0	0	0	499	2,309	
5:45 PM	0	0	59	35	0	0	125	35	0	103	0	113	0	0	0	0	470	2,202	
Count Total	1	1	671	309	0	0	1,048	405	0	959	0	1,066	0	0	0	0	4,460	0	
Peak Hour	All	0	0	348	174	0	0	514	228	0	526	0	605	0	0	0	0	2,395	0
	HV	0	0	0	2	0	0	7	4	0	15	0	9	0	0	0	0	37	0
	HV%	-	-	0%	1%	-	-	1%	2%	-	3%	-	1%	-	-	-	-	2%	0

Note: Two-hour count summary volumes include heavy vehicles but exclude bicycles in overall count.

Interval Start	Heavy Vehicle Totals					Bicycles					Pedestrians (Crossing Leg)				
	EB	WB	NB	SB	Total	EB	WB	NB	SB	Total	East	West	North	South	Total
4:00 PM	1	8	15	0	24	0	0	0	0	0	0	0	0	0	0
4:15 PM	1	6	11	0	18	0	0	0	0	0	0	0	0	0	0
4:30 PM	0	6	9	0	15	0	0	0	0	0	0	0	0	0	0
4:45 PM	2	4	5	0	11	0	0	0	0	0	0	0	0	0	0
5:00 PM	0	1	5	0	6	0	0	0	0	0	0	0	0	0	0
5:15 PM	0	0	5	0	5	0	0	0	0	0	0	0	0	0	0
5:30 PM	0	0	2	0	2	0	0	0	0	0	0	0	0	0	0
5:45 PM	0	4	1	0	5	0	0	0	0	0	0	0	0	0	0
Count Total	4	29	53	0	86	0	0	0	0	0	0	0	0	0	0
Peak Hour	2	11	24	0	37	0	0	0	0	0	0	0	0	0	0

<b>Two-Hour Count Summaries - Heavy Vehicles</b>																		
Interval Start	Shiloh Rd				Shiloh Rd				US-101 NB Ramps				US-101 NB Ramps				15-min Total	Rolling One Hour
	Eastbound				Westbound				Northbound				Southbound					
	UT	LT	TH	RT	UT	LT	TH	RT	UT	LT	TH	RT	UT	LT	TH	RT		
4:00 PM	0	0	0	1	0	0	6	2	0	14	0	1	0	0	0	0	24	0
4:15 PM	0	0	1	0	0	0	5	1	0	11	0	0	0	0	0	0	18	0
4:30 PM	0	0	0	0	0	0	3	3	0	6	0	3	0	0	0	0	15	0
4:45 PM	0	0	0	2	0	0	4	0	0	4	0	1	0	0	0	0	11	68
5:00 PM	0	0	0	0	0	0	0	1	0	3	0	2	0	0	0	0	6	50
5:15 PM	0	0	0	0	0	0	0	0	0	2	0	3	0	0	0	0	5	37
5:30 PM	0	0	0	0	0	0	0	0	0	1	0	1	0	0	0	0	2	24
5:45 PM	0	0	0	0	0	0	4	0	0	1	0	0	0	0	0	0	5	18
Count Total	0	0	1	3	0	0	22	7	0	42	0	11	0	0	0	0	86	0
Peak Hour	0	0	0	2	0	0	7	4	0	15	0	9	0	0	0	0	37	0
<b>Two-Hour Count Summaries - Bikes</b>																		
Interval Start	Shiloh Rd			Shiloh Rd			US-101 NB Ramps			US-101 NB Ramps			15-min Total	Rolling One Hour				
	Eastbound			Westbound			Northbound			Southbound								
	LT	TH	RT	LT	TH	RT	LT	TH	RT	LT	TH	RT						
4:00 PM	0	0	0	0	0	0	0	0	0	0	0	0	0	0	0	0	0	0
4:15 PM	0	0	0	0	0	0	0	0	0	0	0	0	0	0	0	0	0	0
4:30 PM	0	0	0	0	0	0	0	0	0	0	0	0	0	0	0	0	0	0
4:45 PM	0	0	0	0	0	0	0	0	0	0	0	0	0	0	0	0	0	0
5:00 PM	0	0	0	0	0	0	0	0	0	0	0	0	0	0	0	0	0	0
5:15 PM	0	0	0	0	0	0	0	0	0	0	0	0	0	0	0	0	0	0
5:30 PM	0	0	0	0	0	0	0	0	0	0	0	0	0	0	0	0	0	0
5:45 PM	0	0	0	0	0	0	0	0	0	0	0	0	0	0	0	0	0	0
Count Total	0	0	0	0	0	0	0	0	0	0	0	0	0	0	0	0	0	0
Peak Hour	0	0	0	0	0	0	0	0	0	0	0	0	0	0	0	0	0	0
<i>Note: U-Turn volumes for bikes are included in Left-Turn, if any.</i>																		



## US-101 SB Ramps Shiloh Rd

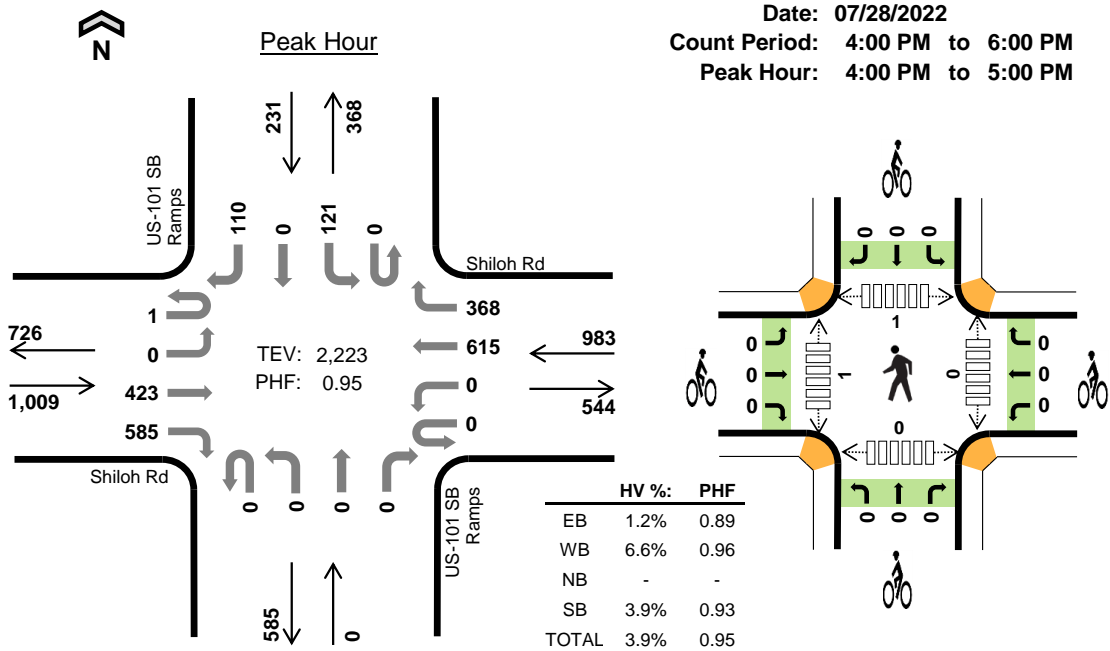

### Two-Hour Count Summaries

Interval Start	Shiloh Rd Eastbound				Shiloh Rd Westbound				US-101 SB Ramps Northbound				US-101 SB Ramps Southbound				15-min Total	Rolling One Hour	
	UT	LT	TH	RT	UT	LT	TH	RT	UT	LT	TH	RT	UT	LT	TH	RT			
4:00 PM	0	0	114	171	0	0	165	91	0	0	0	0	0	26	0	21	588	0	
4:15 PM	0	0	99	136	0	0	134	102	0	0	0	0	0	30	0	30	531	0	
4:30 PM	1	0	105	152	0	0	155	96	0	0	0	0	0	38	0	24	571	0	
4:45 PM	0	0	105	126	0	0	161	79	0	0	0	0	0	27	0	35	533	2,223	
5:00 PM	1	0	99	108	0	0	170	81	0	0	0	0	0	30	0	23	512	2,147	
5:15 PM	0	0	101	103	0	0	205	86	0	0	0	0	0	22	0	31	548	2,164	
5:30 PM	0	0	71	84	0	0	170	87	0	0	0	0	0	31	0	26	469	2,062	
5:45 PM	0	0	68	87	0	0	140	86	0	0	0	0	0	21	0	19	421	1,950	
Count Total	2	0	762	967	0	0	1,300	708	0	0	0	0	0	225	0	209	4,173	0	
Peak Hour	All	1	0	423	585	0	0	615	368	0	0	0	0	0	121	0	110	2,223	0
	HV	0	0	5	7	0	0	45	20	0	0	0	0	0	1	0	8	86	0
	HV%	0%	-	1%	1%	-	-	7%	5%	-	-	-	-	-	1%	-	7%	4%	0

Note: Two-hour count summary volumes include heavy vehicles but exclude bicycles in overall count.

Interval Start	Heavy Vehicle Totals					Bicycles					Pedestrians (Crossing Leg)				
	EB	WB	NB	SB	Total	EB	WB	NB	SB	Total	East	West	North	South	Total
4:00 PM	4	31	0	4	39	0	0	0	0	0	0	0	0	0	0
4:15 PM	3	16	0	1	20	0	0	0	0	0	0	0	0	0	0
4:30 PM	2	10	0	2	14	0	0	0	0	0	0	0	0	0	0
4:45 PM	3	8	0	2	13	0	0	0	0	0	0	1	1	0	2
5:00 PM	3	6	0	0	9	0	0	0	0	0	0	0	0	0	0
5:15 PM	2	3	0	0	5	0	0	0	0	0	0	0	0	0	0
5:30 PM	1	2	0	0	3	0	0	0	0	0	0	0	0	0	0
5:45 PM	1	4	0	0	5	0	0	0	0	0	0	0	0	0	0
Count Total	19	80	0	9	108	0	0	0	0	0	0	1	1	0	2
Peak Hour	12	65	0	9	86	0	0	0	0	0	0	1	1	0	2

<b>Two-Hour Count Summaries - Heavy Vehicles</b>														15-min Total	Rolling One Hour			
Interval Start	Shiloh Rd				Shiloh Rd				US-101 SB Ramps				US-101 SB Ramps					
	Eastbound				Westbound				Northbound				Southbound					
	UT	LT	TH	RT	UT	LT	TH	RT	UT	LT	TH	RT	UT	LT	TH	RT		
4:00 PM	0	0	1	3	0	0	21	10	0	0	0	0	0	1	0	3	39	0
4:15 PM	0	0	2	1	0	0	12	4	0	0	0	0	0	0	0	1	20	0
4:30 PM	0	0	0	2	0	0	7	3	0	0	0	0	0	0	0	2	14	0
4:45 PM	0	0	2	1	0	0	5	3	0	0	0	0	0	0	0	2	13	86
5:00 PM	0	0	1	2	0	0	4	2	0	0	0	0	0	0	0	0	9	56
5:15 PM	0	0	0	2	0	0	3	0	0	0	0	0	0	0	0	0	5	41
5:30 PM	0	0	0	1	0	0	2	0	0	0	0	0	0	0	0	0	3	30
5:45 PM	0	0	0	1	0	0	1	3	0	0	0	0	0	0	0	0	5	22
Count Total	0	0	6	13	0	0	55	25	0	0	0	0	0	1	0	8	108	0
Peak Hour	0	0	5	7	0	0	45	20	0	0	0	0	0	1	0	8	86	0

<b>Two-Hour Count Summaries - Bikes</b>														15-min Total	Rolling One Hour			
Interval Start	Shiloh Rd			Shiloh Rd			US-101 SB Ramps			US-101 SB Ramps								
	Eastbound			Westbound			Northbound			Southbound								
	LT	TH	RT	LT	TH	RT	LT	TH	RT	LT	TH	RT						
4:00 PM	0	0	0	0	0	0	0	0	0	0	0	0	0	0	0	0	0	0
4:15 PM	0	0	0	0	0	0	0	0	0	0	0	0	0	0	0	0	0	0
4:30 PM	0	0	0	0	0	0	0	0	0	0	0	0	0	0	0	0	0	0
4:45 PM	0	0	0	0	0	0	0	0	0	0	0	0	0	0	0	0	0	0
5:00 PM	0	0	0	0	0	0	0	0	0	0	0	0	0	0	0	0	0	0
5:15 PM	0	0	0	0	0	0	0	0	0	0	0	0	0	0	0	0	0	0
5:30 PM	0	0	0	0	0	0	0	0	0	0	0	0	0	0	0	0	0	0
5:45 PM	0	0	0	0	0	0	0	0	0	0	0	0	0	0	0	0	0	0
Count Total	0	0	0	0	0	0	0	0	0	0	0	0	0	0	0	0	0	0
Peak Hour	0	0	0	0	0	0	0	0	0	0	0	0	0	0	0	0	0	0

Note: U-Turn volumes for bikes are included in Left-Turn, if any.

# Caletti Ave Shiloh Rd



Peak Hour

Date: 07/28/2022

Count Period: 4:00 PM to 6:00 PM

Peak Hour: 4:00 PM to 5:00 PM

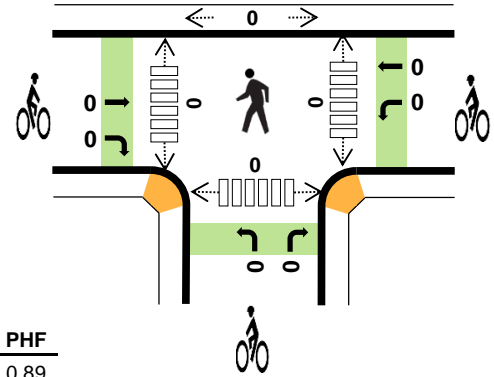
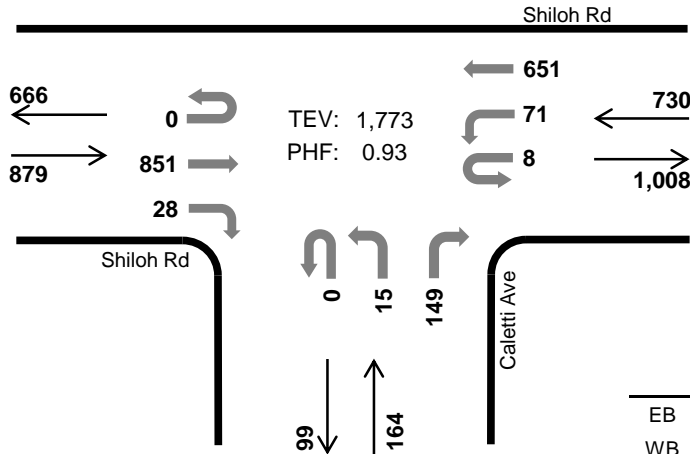

	HV %:	PHF
EB	1.8%	0.89
WB	6.7%	0.92
NB	2.4%	0.89
SB	-	-
TOTAL	3.9%	0.93

## Two-Hour Count Summaries

Interval Start	Shiloh Rd Eastbound				Shiloh Rd Westbound				Caletti Ave Northbound				n/a Southbound				15-min Total	Rolling One Hour	
	UT	LT	TH	RT	UT	LT	TH	RT	UT	LT	TH	RT	UT	LT	TH	RT			
4:00 PM	0	0	239	8	0	25	159	0	0	2	0	44	0	0	0	0	477	0	
4:15 PM	0	0	192	4	2	17	152	0	0	5	0	39	0	0	0	0	411	0	
4:30 PM	0	0	220	4	3	20	154	0	0	3	0	35	0	0	0	0	439	0	
4:45 PM	0	0	200	12	3	9	186	0	0	5	0	31	0	0	0	0	446	1,773	
5:00 PM	0	0	184	3	2	12	175	0	0	3	0	21	0	0	0	0	400	1,696	
5:15 PM	0	0	176	2	2	12	225	0	0	3	0	21	0	0	0	0	441	1,726	
5:30 PM	0	0	140	4	2	9	190	0	0	2	0	14	0	0	0	0	361	1,648	
5:45 PM	0	0	136	1	2	7	143	0	0	1	0	17	0	0	0	0	307	1,509	
Count Total	0	0	1,487	38	16	111	1,384	0	0	24	0	222	0	0	0	0	3,282	0	
Peak Hour	All	0	0	851	28	8	71	651	0	0	15	0	149	0	0	0	0	1,773	0
	HV	0	0	8	8	0	27	22	0	0	1	0	3	0	0	0	0	69	0
	HV%	-	-	1%	29%	0%	38%	3%	-	-	7%	-	2%	-	-	-	-	4%	0

Note: Two-hour count summary volumes include heavy vehicles but exclude bicycles in overall count.

Interval Start	Heavy Vehicle Totals					Bicycles					Pedestrians (Crossing Leg)				
	EB	WB	NB	SB	Total	EB	WB	NB	SB	Total	East	West	North	South	Total
4:00 PM	6	21	1	0	28	0	0	0	0	0	0	0	0	0	0
4:15 PM	2	12	2	0	16	0	0	0	0	0	0	0	0	0	0
4:30 PM	3	9	1	0	13	0	0	0	0	0	0	0	0	0	0
4:45 PM	5	7	0	0	12	0	0	0	0	0	0	0	0	0	0
5:00 PM	3	3	0	0	6	0	0	0	0	0	0	0	0	0	0
5:15 PM	2	3	0	0	5	0	0	0	0	0	0	0	0	0	0
5:30 PM	2	2	0	0	4	0	0	0	0	0	0	0	0	0	0
5:45 PM	1	2	0	0	3	0	0	0	0	0	0	0	0	0	0
Count Total	24	59	4	0	87	0	0	0	0	0	0	0	0	0	0
Peak Hr	16	49	4	0	69	0	0	0	0	0	0	0	0	0	0

**Two-Hour Count Summaries - Heavy Vehicles**

Interval Start	Shiloh Rd				Shiloh Rd				Caletti Ave				n/a				15-min Total	Rolling One Hour
	Eastbound				Westbound				Northbound				Southbound					
	UT	LT	TH	RT	UT	LT	TH	RT	UT	LT	TH	RT	UT	LT	TH	RT		
4:00 PM	0	0	3	3	0	15	6	0	0	0	0	1	0	0	0	0	28	0
4:15 PM	0	0	2	0	0	6	6	0	0	1	0	1	0	0	0	0	16	0
4:30 PM	0	0	1	2	0	3	6	0	0	0	0	1	0	0	0	0	13	0
4:45 PM	0	0	2	3	0	3	4	0	0	0	0	0	0	0	0	0	12	69
5:00 PM	0	0	2	1	0	2	1	0	0	0	0	0	0	0	0	0	6	47
5:15 PM	0	0	2	0	0	1	2	0	0	0	0	0	0	0	0	0	5	36
5:30 PM	0	0	1	1	0	1	1	0	0	0	0	0	0	0	0	0	4	27
5:45 PM	0	0	1	0	0	2	0	0	0	0	0	0	0	0	0	0	3	18
Count Total	0	0	14	10	0	33	26	0	0	1	0	3	0	0	0	0	87	0
Peak Hour	0	0	8	8	0	27	22	0	0	1	0	3	0	0	0	0	69	0

**Two-Hour Count Summaries - Bikes**

Interval Start	Shiloh Rd			Shiloh Rd			Caletti Ave			n/a			15-min Total	Rolling One Hour
	Eastbound			Westbound			Northbound			Southbound				
	LT	TH	RT	LT	TH	RT	LT	TH	RT	LT	TH	RT		
4:00 PM	0	0	0	0	0	0	0	0	0	0	0	0	0	0
4:15 PM	0	0	0	0	0	0	0	0	0	0	0	0	0	0
4:30 PM	0	0	0	0	0	0	0	0	0	0	0	0	0	0
4:45 PM	0	0	0	0	0	0	0	0	0	0	0	0	0	0
5:00 PM	0	0	0	0	0	0	0	0	0	0	0	0	0	0
5:15 PM	0	0	0	0	0	0	0	0	0	0	0	0	0	0
5:30 PM	0	0	0	0	0	0	0	0	0	0	0	0	0	0
5:45 PM	0	0	0	0	0	0	0	0	0	0	0	0	0	0
Count Total	0	0	0	0	0	0	0	0	0	0	0	0	0	0
Peak Hour	0	0	0	0	0	0	0	0	0	0	0	0	0	0

Note: U-Turn volumes for bikes are included in Left-Turn, if any.

### Conde Ln Shiloh Rd



Peak Hour

Date: 07/28/2022  
Count Period: 4:00 PM to 6:00 PM  
Peak Hour: 4:30 PM to 5:30 PM

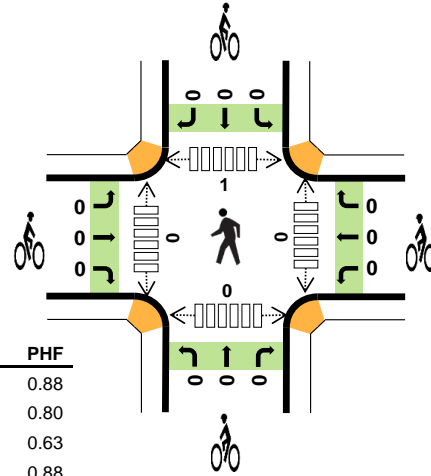
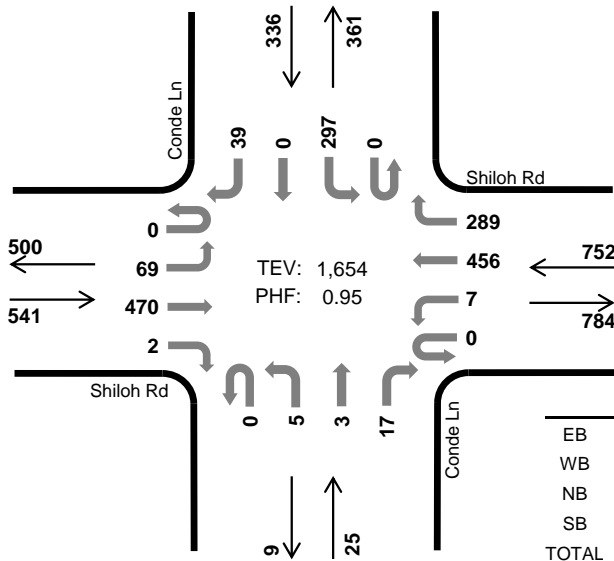

	HV %:	PHF
EB	1.7%	0.88
WB	2.1%	0.80
NB	0.0%	0.63
SB	2.7%	0.88
TOTAL	2.1%	0.95

#### Two-Hour Count Summaries

Interval Start	Shiloh Rd Eastbound				Shiloh Rd Westbound				Conde Ln Northbound				Conde Ln Southbound				15-min Total	Rolling One Hour	
	UT	LT	TH	RT	UT	LT	TH	RT	UT	LT	TH	RT	UT	LT	TH	RT			
4:00 PM	0	15	150	1	0	4	93	60	0	7	0	6	0	82	0	6	424	0	
4:15 PM	0	15	129	1	0	1	100	55	0	0	2	5	0	60	0	9	377	0	
4:30 PM	0	14	138	2	0	1	92	63	0	1	0	6	0	77	0	7	401	0	
4:45 PM	0	9	118	0	0	1	112	71	0	1	3	6	0	86	0	9	416	1,618	
5:00 PM	0	23	110	0	0	5	111	62	0	1	0	4	0	71	0	13	400	1,594	
5:15 PM	0	23	104	0	0	0	141	93	0	2	0	1	0	63	0	10	437	1,654	
5:30 PM	0	17	93	0	0	2	130	63	0	1	0	2	0	50	0	10	368	1,621	
5:45 PM	0	7	91	0	0	1	85	59	0	2	0	1	0	43	0	4	293	1,498	
Count Total	0	123	933	4	0	15	864	526	0	15	5	31	0	532	0	68	3,116	0	
Peak Hour	All	0	69	470	2	0	7	456	289	0	5	3	17	0	297	0	39	1,654	0
	HV	0	2	7	0	0	2	9	5	0	0	0	0	0	8	0	1	34	0
	HV%	-	3%	1%	0%	-	29%	2%	2%	-	0%	0%	0%	-	3%	-	3%	2%	0

Note: Two-hour count summary volumes include heavy vehicles but exclude bicycles in overall count.

Interval Start	Heavy Vehicle Totals					Bicycles					Pedestrians (Crossing Leg)				
	EB	WB	NB	SB	Total	EB	WB	NB	SB	Total	East	West	North	South	Total
4:00 PM	7	9	0	3	19	0	0	0	0	0	0	0	0	0	0
4:15 PM	3	7	0	0	10	0	0	0	0	0	0	0	0	0	0
4:30 PM	2	6	0	3	11	0	0	0	0	0	0	0	0	0	0
4:45 PM	3	5	0	3	11	0	0	0	0	0	0	0	1	0	1
5:00 PM	3	3	0	3	9	0	0	0	0	0	0	0	0	0	0
5:15 PM	1	2	0	0	3	0	0	0	0	0	0	0	0	0	0
5:30 PM	2	1	0	0	3	0	0	0	0	0	0	0	0	0	0
5:45 PM	1	0	0	0	1	0	0	0	0	0	0	0	0	0	0
Count Total	22	33	0	12	67	0	0	0	0	0	0	0	1	0	1
Peak Hour	9	16	0	9	34	0	0	0	0	0	0	0	1	0	1

<b>Two-Hour Count Summaries - Heavy Vehicles</b>																		
Interval Start	Shiloh Rd				Shiloh Rd				Conde Ln				Conde Ln				15-min Total	Rolling One Hour
	Eastbound				Westbound				Northbound				Southbound					
	UT	LT	TH	RT	UT	LT	TH	RT	UT	LT	TH	RT	UT	LT	TH	RT		
4:00 PM	0	2	5	0	0	2	3	4	0	0	0	0	0	3	0	0	19	0
4:15 PM	0	2	1	0	0	0	4	3	0	0	0	0	0	0	0	0	10	0
4:30 PM	0	1	1	0	0	1	4	1	0	0	0	0	0	2	0	1	11	0
4:45 PM	0	0	3	0	0	0	3	2	0	0	0	0	0	3	0	0	11	51
5:00 PM	0	1	2	0	0	1	0	2	0	0	0	0	0	3	0	0	9	41
5:15 PM	0	0	1	0	0	0	2	0	0	0	0	0	0	0	0	0	3	34
5:30 PM	0	0	2	0	0	0	1	0	0	0	0	0	0	0	0	0	3	26
5:45 PM	0	0	1	0	0	0	0	0	0	0	0	0	0	0	0	0	1	16
Count Total	0	6	16	0	0	4	17	12	0	0	0	0	0	11	0	1	67	0
Peak Hour	0	2	7	0	0	2	9	5	0	0	0	0	0	8	0	1	34	0

<b>Two-Hour Count Summaries - Bikes</b>																		
Interval Start	Shiloh Rd			Shiloh Rd			Conde Ln			Conde Ln			15-min Total	Rolling One Hour				
	Eastbound			Westbound			Northbound			Southbound								
	LT	TH	RT	LT	TH	RT	LT	TH	RT	LT	TH	RT						
4:00 PM	0	0	0	0	0	0	0	0	0	0	0	0	0	0	0	0	0	0
4:15 PM	0	0	0	0	0	0	0	0	0	0	0	0	0	0	0	0	0	0
4:30 PM	0	0	0	0	0	0	0	0	0	0	0	0	0	0	0	0	0	0
4:45 PM	0	0	0	0	0	0	0	0	0	0	0	0	0	0	0	0	0	0
5:00 PM	0	0	0	0	0	0	0	0	0	0	0	0	0	0	0	0	0	0
5:15 PM	0	0	0	0	0	0	0	0	0	0	0	0	0	0	0	0	0	0
5:30 PM	0	0	0	0	0	0	0	0	0	0	0	0	0	0	0	0	0	0
5:45 PM	0	0	0	0	0	0	0	0	0	0	0	0	0	0	0	0	0	0
Count Total	0	0	0	0	0	0	0	0	0	0	0	0	0	0	0	0	0	0
Peak Hour	0	0	0	0	0	0	0	0	0	0	0	0	0	0	0	0	0	0

Note: U-Turn volumes for bikes are included in Left-Turn, if any.

### Gridley Dr Shiloh Rd



Date: 07/28/2022  
 Count Period: 4:00 PM to 6:00 PM  
 Peak Hour: 4:00 PM to 5:00 PM

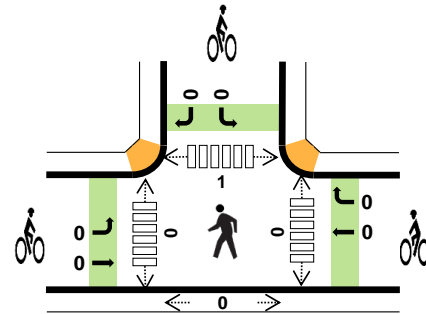
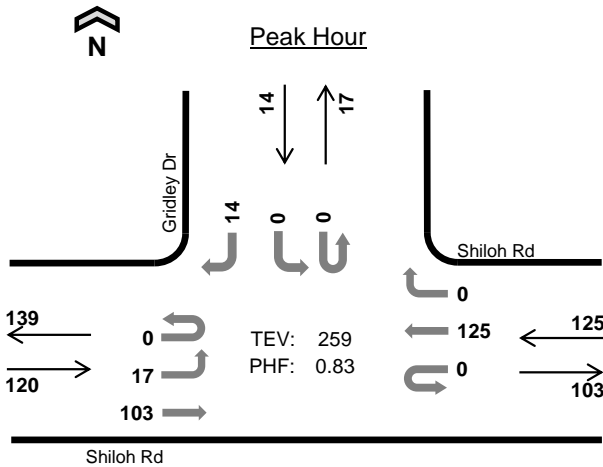

	HV %:	PHF
EB	0.8%	0.94
WB	6.4%	0.69
NB	-	-
SB	0.0%	0.58
TOTAL	3.5%	0.83

#### Two-Hour Count Summaries

Interval Start	Shiloh Rd Eastbound				Shiloh Rd Westbound				N/A Northbound				Gridley Dr Southbound				15-min Total	Rolling One Hour
	UT	LT	TH	RT	UT	LT	TH	RT	UT	LT	TH	RT	UT	LT	TH	RT		
4:00 PM	0	5	24	0	0	0	45	0	0	0	0	0	0	0	0	4	78	0
4:15 PM	0	5	25	0	0	0	27	0	0	0	0	0	0	0	0	0	57	0
4:30 PM	0	5	24	0	0	0	31	0	0	0	0	0	0	0	0	4	64	0
4:45 PM	0	2	30	0	0	0	22	0	0	0	0	0	0	0	0	6	60	259
5:00 PM	0	5	15	0	0	0	31	0	0	0	0	0	0	0	0	4	55	236
5:15 PM	0	9	26	0	1	0	20	1	0	0	0	0	0	0	0	2	59	238
5:30 PM	0	2	26	0	0	0	26	0	0	0	0	0	0	0	0	2	56	230
5:45 PM	0	0	22	0	0	0	22	1	0	0	0	0	0	0	0	3	48	218
Count Total	0	33	192	0	1	0	224	2	0	0	0	0	0	0	0	25	477	0
Peak Hour	All	0	17	103	0	0	0	125	0	0	0	0	0	0	0	14	259	0
	HV	0	0	1	0	0	0	8	0	0	0	0	0	0	0	0	9	0
	HV%	-	0%	1%	-	-	-	6%	-	-	-	-	-	-	-	0%	3%	0

Note: Two-hour count summary volumes include heavy vehicles but exclude bicycles in overall count.

Interval Start	Heavy Vehicle Totals					Bicycles					Pedestrians (Crossing Leg)				
	EB	WB	NB	SB	Total	EB	WB	NB	SB	Total	East	West	North	South	Total
4:00 PM	0	6	0	0	6	0	0	0	0	0	0	0	1	0	1
4:15 PM	0	0	0	0	0	0	0	0	0	0	0	0	0	0	0
4:30 PM	0	2	0	0	2	0	0	0	0	0	0	0	0	0	0
4:45 PM	1	0	0	0	1	0	0	0	0	0	0	0	0	0	0
5:00 PM	1	0	0	0	1	0	0	0	0	0	0	0	1	0	1
5:15 PM	0	0	0	0	0	0	0	0	0	0	0	0	0	0	0
5:30 PM	1	0	0	0	1	0	0	0	0	0	0	0	0	0	0
5:45 PM	0	0	0	0	0	0	0	0	0	0	0	0	0	1	1
Count Total	3	8	0	0	11	0	0	0	0	0	0	0	2	1	3
Peak Hr	1	8	0	0	9	0	0	0	0	0	0	0	1	0	1

Two-Hour Count Summaries - Heavy Vehicles																		
Interval Start	Shiloh Rd				Shiloh Rd				N/A				Gridley Dr				15-min Total	Rolling One Hour
	Eastbound				Westbound				Northbound				Southbound					
	UT	LT	TH	RT	UT	LT	TH	RT	UT	LT	TH	RT	UT	LT	TH	RT		
4:00 PM	0	0	0	0	0	0	6	0	0	0	0	0	0	0	0	0	6	0
4:15 PM	0	0	0	0	0	0	0	0	0	0	0	0	0	0	0	0	0	0
4:30 PM	0	0	0	0	0	0	2	0	0	0	0	0	0	0	0	0	2	0
4:45 PM	0	0	1	0	0	0	0	0	0	0	0	0	0	0	0	0	1	9
5:00 PM	0	0	1	0	0	0	0	0	0	0	0	0	0	0	0	0	1	4
5:15 PM	0	0	0	0	0	0	0	0	0	0	0	0	0	0	0	0	0	4
5:30 PM	0	0	1	0	0	0	0	0	0	0	0	0	0	0	0	0	1	3
5:45 PM	0	0	0	0	0	0	0	0	0	0	0	0	0	0	0	0	0	2
Count Total	0	0	3	0	0	0	8	0	0	0	0	0	0	0	0	0	11	0
Peak Hour	0	0	1	0	0	0	8	0	0	0	0	0	0	0	0	0	9	0

  

Two-Hour Count Summaries - Bikes														
Interval Start	Shiloh Rd			Shiloh Rd			N/A			Gridley Dr			15-min Total	Rolling One Hour
	Eastbound			Westbound			Northbound			Southbound				
	LT	TH	RT	LT	TH	RT	LT	TH	RT	LT	TH	RT		
4:00 PM	0	0	0	0	0	0	0	0	0	0	0	0	0	0
4:15 PM	0	0	0	0	0	0	0	0	0	0	0	0	0	0
4:30 PM	0	0	0	0	0	0	0	0	0	0	0	0	0	0
4:45 PM	0	0	0	0	0	0	0	0	0	0	0	0	0	0
5:00 PM	0	0	0	0	0	0	0	0	0	0	0	0	0	0
5:15 PM	0	0	0	0	0	0	0	0	0	0	0	0	0	0
5:30 PM	0	0	0	0	0	0	0	0	0	0	0	0	0	0
5:45 PM	0	0	0	0	0	0	0	0	0	0	0	0	0	0
Count Total	0	0	0	0	0	0	0	0	0	0	0	0	0	0
Peak Hour	0	0	0	0	0	0	0	0	0	0	0	0	0	0

Note: U-Turn volumes for bikes are included in Left-Turn, if any.



# Old Redwood Hwy Shiloh Neighborhood Church South

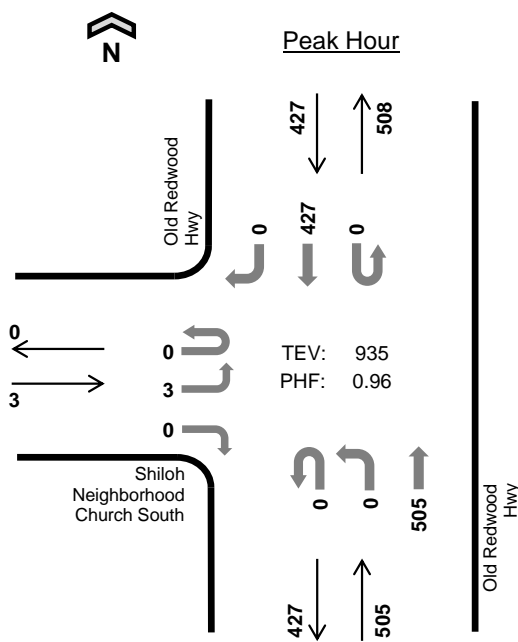

Date: 07/28/2022  
 Count Period: 4:00 PM to 6:00 PM  
 Peak Hour: 4:30 PM to 5:30 PM

	HV %:	PHF
EB	0.0%	0.38
WB	-	-
NB	0.6%	0.91
SB	1.2%	0.94
TOTAL	0.9%	0.96

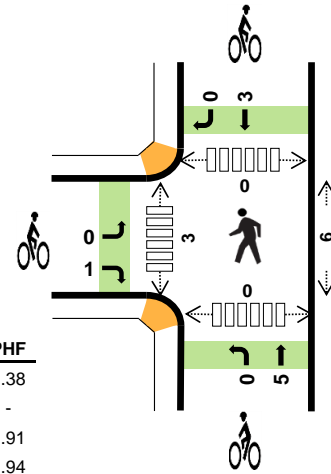

### Two-Hour Count Summaries

Interval Start	Shiloh Neighborhood Church South				n/a				Old Redwood Hwy				Old Redwood Hwy				15-min Total	Rolling One Hour	
	Eastbound		Westbound		Northbound		Southbound		UT		TH		RT						
4:00 PM	0	0	0	0	0	0	0	0	0	0	98	0	0	0	108	0	206	0	
4:15 PM	0	0	0	1	0	0	0	0	0	0	110	0	0	0	119	0	230	0	
<b>4:30 PM</b>	<b>0</b>	<b>1</b>	<b>0</b>	<b>0</b>	<b>0</b>	<b>0</b>	<b>0</b>	<b>0</b>	<b>0</b>	<b>0</b>	<b>139</b>	<b>0</b>	<b>0</b>	<b>0</b>	<b>100</b>	<b>0</b>	<b>240</b>	<b>0</b>	
4:45 PM	0	2	0	0	0	0	0	0	0	0	128	0	0	0	101	0	231	907	
5:00 PM	0	0	0	0	0	0	0	0	0	0	108	0	0	0	113	0	221	922	
<b>5:15 PM</b>	<b>0</b>	<b>0</b>	<b>0</b>	<b>0</b>	<b>0</b>	<b>0</b>	<b>0</b>	<b>0</b>	<b>0</b>	<b>0</b>	<b>130</b>	<b>0</b>	<b>0</b>	<b>0</b>	<b>113</b>	<b>0</b>	<b>243</b>	<b>935</b>	
5:30 PM	0	0	0	0	0	0	0	0	0	0	116	0	0	0	100	0	216	911	
5:45 PM	0	0	0	0	0	0	0	0	0	0	116	0	0	0	83	1	200	880	
Count Total	0	3	0	1	0	0	0	0	0	0	945	0	0	0	837	1	1,787	0	
Peak Hour	All	0	3	0	0	0	0	0	0	0	0	505	0	0	0	427	0	935	0
	HV	0	0	0	0	0	0	0	0	0	0	3	0	0	0	5	0	8	0
	HV%	-	0%	-	-	-	-	-	-	-	-	1%	-	-	-	1%	-	1%	0

Note: Two-hour count summary volumes include heavy vehicles but exclude bicycles in overall count.

Interval Start	Heavy Vehicle Totals					Bicycles					Pedestrians (Crossing Leg)				
	EB	WB	NB	SB	Total	EB	WB	NB	SB	Total	East	West	North	South	Total
4:00 PM	0	0	1	2	3	0	0	0	1	1	0	2	0	0	2
4:15 PM	0	0	2	3	5	0	0	2	0	2	3	0	0	0	3
<b>4:30 PM</b>	<b>0</b>	<b>0</b>	<b>0</b>	<b>1</b>	<b>1</b>	<b>1</b>	<b>0</b>	<b>0</b>	<b>0</b>	<b>1</b>	<b>0</b>	<b>0</b>	<b>0</b>	<b>0</b>	<b>0</b>
4:45 PM	0	0	1	3	4	0	0	1	0	1	0	0	0	0	0
5:00 PM	0	0	1	1	2	0	0	2	3	5	2	2	0	0	4
<b>5:15 PM</b>	<b>0</b>	<b>0</b>	<b>1</b>	<b>0</b>	<b>1</b>	<b>0</b>	<b>0</b>	<b>2</b>	<b>0</b>	<b>2</b>	<b>4</b>	<b>1</b>	<b>0</b>	<b>0</b>	<b>5</b>
5:30 PM	0	0	0	1	1	0	0	0	0	0	0	0	0	0	0
5:45 PM	0	0	1	1	2	0	0	3	0	3	4	0	0	0	4
Count Total	0	0	7	12	19	1	0	10	4	15	13	5	0	0	18
Peak Hr	0	0	3	5	8	1	0	5	3	9	6	3	0	0	9

<b>Two-Hour Count Summaries - Heavy Vehicles</b>														15-min Total	Rolling One Hour			
Interval Start	Shiloh Neighborhood Church South				n/a				Old Redwood Hwy				Old Redwood Hwy					
	Eastbound				Westbound				Northbound				Southbound					
	UT	LT	TH	RT	UT	LT	TH	RT	UT	LT	TH	RT	UT	LT	TH	RT		
4:00 PM	0	0	0	0	0	0	0	0	0	0	1	0	0	0	2	0	3	0
4:15 PM	0	0	0	0	0	0	0	0	0	0	2	0	0	0	3	0	5	0
4:30 PM	0	0	0	0	0	0	0	0	0	0	0	0	0	0	1	0	1	0
4:45 PM	0	0	0	0	0	0	0	0	0	0	1	0	0	0	3	0	4	13
5:00 PM	0	0	0	0	0	0	0	0	0	0	1	0	0	0	1	0	2	12
5:15 PM	0	0	0	0	0	0	0	0	0	0	1	0	0	0	0	0	1	8
5:30 PM	0	0	0	0	0	0	0	0	0	0	0	0	0	0	1	0	1	8
5:45 PM	0	0	0	0	0	0	0	0	0	0	1	0	0	0	1	0	2	6
Count Total	0	0	0	0	0	0	0	0	0	0	7	0	0	0	12	0	19	0
Peak Hour	0	0	0	0	0	0	0	0	0	0	3	0	0	0	5	0	8	0

<b>Two-Hour Count Summaries - Bikes</b>														15-min Total	Rolling One Hour			
Interval Start	Shiloh Neighborhood Church South				n/a				Old Redwood Hwy				Old Redwood Hwy					
	Eastbound				Westbound				Northbound				Southbound					
	LT	TH	RT	LT	TH	RT	LT	TH	RT	LT	TH	RT	LT	TH	RT			
4:00 PM	0	0	0	0	0	0	0	0	0	0	1	0	0	0	0	1	0	
4:15 PM	0	0	0	0	0	0	0	2	0	0	0	0	0	0	0	2	0	
4:30 PM	0	0	1	0	0	0	0	0	0	0	0	0	0	0	0	1	0	
4:45 PM	0	0	0	0	0	0	0	1	0	0	0	0	0	0	0	1	5	
5:00 PM	0	0	0	0	0	0	0	2	0	0	3	0	0	0	0	5	9	
5:15 PM	0	0	0	0	0	0	0	2	0	0	0	0	0	0	0	2	9	
5:30 PM	0	0	0	0	0	0	0	0	0	0	0	0	0	0	0	0	8	
5:45 PM	0	0	0	0	0	0	0	3	0	0	0	0	0	0	0	3	10	
Count Total	0	0	1	0	0	0	0	10	0	0	4	0	0	0	0	15	0	
Peak Hour	0	0	1	0	0	0	0	5	0	0	3	0	0	0	0	9	0	

Note: U-Turn volumes for bikes are included in Left-Turn, if any.

# Driveway (East of Caporale Ct) Shiloh Rd



Peak Hour

Date: 07/28/2022  
Count Period: 4:00 PM to 6:00 PM  
Peak Hour: 4:00 PM to 5:00 PM

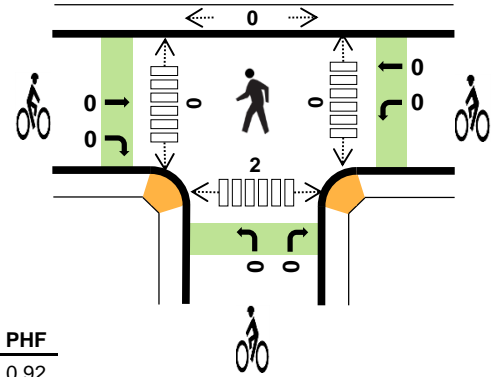
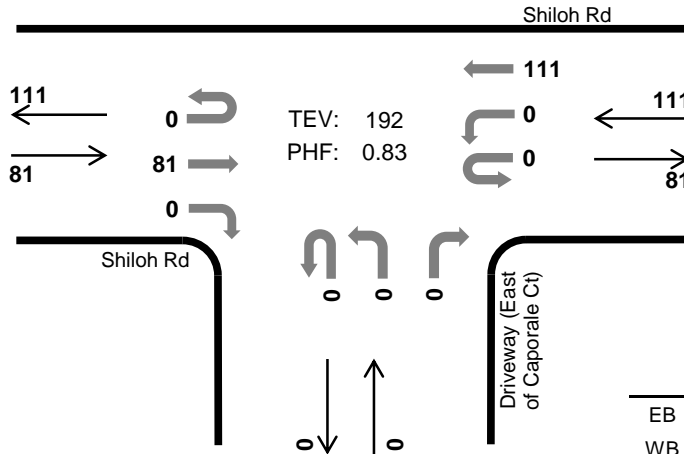

	HV %:	PHF
EB	1.2%	0.92
WB	8.1%	0.68
NB	-	-
SB	-	-
TOTAL	5.2%	0.83

## Two-Hour Count Summaries

Interval Start	Shiloh Rd Eastbound				Shiloh Rd Westbound				Driveway (East of Caporale Ct) Northbound				n/a Southbound				15-min Total	Rolling One Hour
	UT	LT	TH	RT	UT	LT	TH	RT	UT	LT	TH	RT	UT	LT	TH	RT		
4:00 PM	0	0	17	0	0	0	41	0	0	0	0	0	0	0	0	0	58	0
4:15 PM	0	0	22	0	0	0	24	0	0	0	0	0	0	0	0	0	46	0
4:30 PM	0	0	21	0	0	0	27	0	0	0	0	0	0	0	0	0	48	0
4:45 PM	0	0	21	0	0	0	19	0	0	0	0	0	0	0	0	0	40	192
5:00 PM	0	0	16	0	0	0	28	0	0	0	0	0	0	0	0	0	44	178
5:15 PM	0	0	21	0	0	0	17	0	0	0	0	0	0	0	0	0	38	170
5:30 PM	0	0	26	0	0	0	26	0	0	0	0	0	0	0	0	0	52	174
5:45 PM	0	0	19	0	0	0	19	0	0	0	0	0	0	0	0	0	38	172
Count Total	0	0	163	0	0	0	201	0	0	0	0	0	0	0	0	0	364	0
Peak Hour	All	0	0	81	0	0	0	111	0	0	0	0	0	0	0	0	192	0
	HV	0	0	1	0	0	0	9	0	0	0	0	0	0	0	0	10	0
	HV%	-	-	1%	-	-	-	8%	-	-	-	-	-	-	-	-	5%	0

Note: Two-hour count summary volumes include heavy vehicles but exclude bicycles in overall count.

Interval Start	Heavy Vehicle Totals					Bicycles					Pedestrians (Crossing Leg)				
	EB	WB	NB	SB	Total	EB	WB	NB	SB	Total	East	West	North	South	Total
4:00 PM	0	6	0	0	6	0	0	0	0	0	0	0	0	1	1
4:15 PM	1	1	0	0	2	0	0	0	0	0	0	0	0	1	1
4:30 PM	0	2	0	0	2	0	0	0	0	0	0	0	0	0	0
4:45 PM	0	0	0	0	0	0	0	0	0	0	0	0	0	0	0
5:00 PM	1	0	0	0	1	0	0	0	0	0	0	0	1	0	1
5:15 PM	0	0	0	0	0	0	0	0	0	0	0	0	0	0	0
5:30 PM	1	1	0	0	2	0	0	0	0	0	0	0	0	0	0
5:45 PM	0	0	0	0	0	0	0	0	0	0	0	0	0	1	1
Count Total	3	10	0	0	13	0	0	0	0	0	0	0	1	3	4
Peak Hr	1	9	0	0	10	0	0	0	0	0	0	0	0	2	2

**Two-Hour Count Summaries - Heavy Vehicles**

Interval Start	Shiloh Rd				Shiloh Rd				Driveway (East of Caporale Ct)				n/a				15-min Total	Rolling One Hour
	Eastbound				Westbound				Northbound				Southbound					
	UT	LT	TH	RT	UT	LT	TH	RT	UT	LT	TH	RT	UT	LT	TH	RT		
4:00 PM	0	0	0	0	0	0	6	0	0	0	0	0	0	0	0	0	6	0
4:15 PM	0	0	1	0	0	0	1	0	0	0	0	0	0	0	0	0	2	0
4:30 PM	0	0	0	0	0	0	2	0	0	0	0	0	0	0	0	0	2	0
4:45 PM	0	0	0	0	0	0	0	0	0	0	0	0	0	0	0	0	0	10
5:00 PM	0	0	1	0	0	0	0	0	0	0	0	0	0	0	0	0	1	5
5:15 PM	0	0	0	0	0	0	0	0	0	0	0	0	0	0	0	0	0	3
5:30 PM	0	0	1	0	0	0	1	0	0	0	0	0	0	0	0	0	2	3
5:45 PM	0	0	0	0	0	0	0	0	0	0	0	0	0	0	0	0	0	3
Count Total	0	0	3	0	0	0	10	0	0	0	0	0	0	0	0	0	13	0
Peak Hour	0	0	1	0	0	0	9	0	0	0	0	0	0	0	0	0	10	0

**Two-Hour Count Summaries - Bikes**

Interval Start	Shiloh Rd			Shiloh Rd			Driveway (East of Caporale Ct)			n/a			15-min Total	Rolling One Hour
	Eastbound			Westbound			Northbound			Southbound				
	LT	TH	RT	LT	TH	RT	LT	TH	RT	LT	TH	RT		
4:00 PM	0	0	0	0	0	0	0	0	0	0	0	0	0	0
4:15 PM	0	0	0	0	0	0	0	0	0	0	0	0	0	0
4:30 PM	0	0	0	0	0	0	0	0	0	0	0	0	0	0
4:45 PM	0	0	0	0	0	0	0	0	0	0	0	0	0	0
5:00 PM	0	0	0	0	0	0	0	0	0	0	0	0	0	0
5:15 PM	0	0	0	0	0	0	0	0	0	0	0	0	0	0
5:30 PM	0	0	0	0	0	0	0	0	0	0	0	0	0	0
5:45 PM	0	0	0	0	0	0	0	0	0	0	0	0	0	0
Count Total	0	0	0	0	0	0	0	0	0	0	0	0	0	0
Peak Hour	0	0	0	0	0	0	0	0	0	0	0	0	0	0

Note: U-Turn volumes for bikes are included in Left-Turn, if any.

# Lakewood Dr Old Redwood Hwy



Date: 07/28/2022  
 Count Period: 4:00 PM to 6:00 PM  
 Peak Hour: 4:30 PM to 5:30 PM

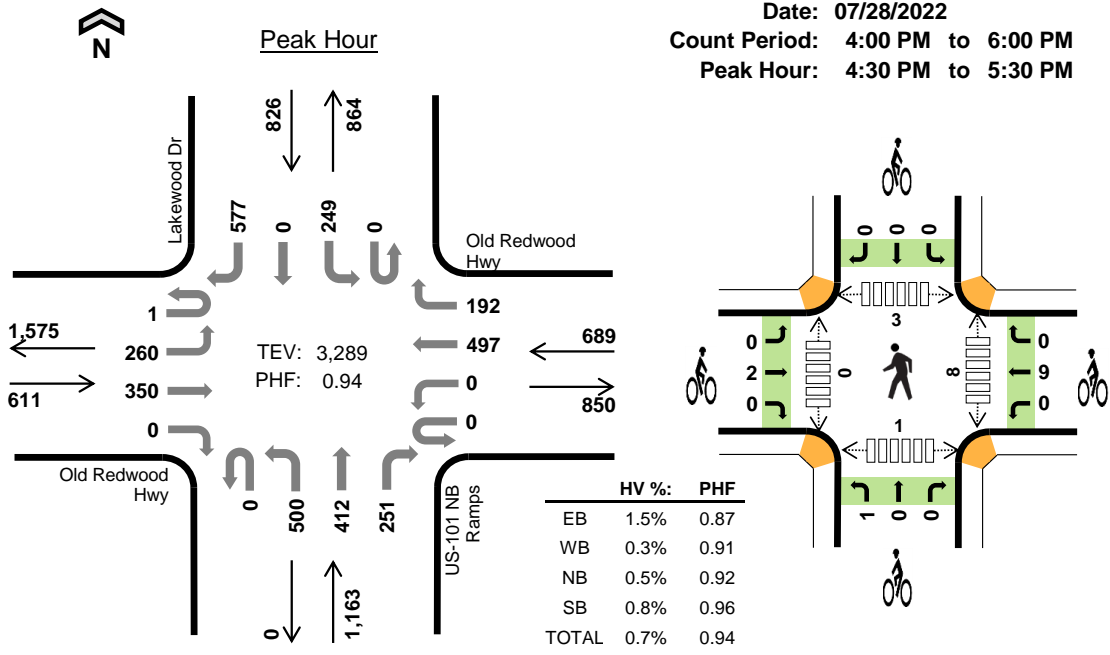

	HV %:	PHF
EB	1.5%	0.87
WB	0.3%	0.91
NB	0.5%	0.92
SB	0.8%	0.96
TOTAL	0.7%	0.94

### Two-Hour Count Summaries

Interval Start	Old Redwood Hwy Eastbound				Old Redwood Hwy Westbound				US-101 NB Ramps Northbound				Lakewood Dr Southbound				15-min Total	Rolling One Hour	
	UT	LT	TH	RT	UT	LT	TH	RT	UT	LT	TH	RT	UT	LT	TH	RT			
	4:00 PM	0	63	91	0	0	0	115	43	0	94	92	39	0	65	0			149
4:15 PM	0	52	82	0	0	0	97	41	0	95	89	34	0	58	0	149	697	0	
4:30 PM	0	78	80	0	0	0	118	51	0	110	92	73	0	57	0	146	805	0	
4:45 PM	1	63	90	0	0	0	104	48	0	106	113	65	0	62	0	152	804	3,057	
5:00 PM	0	46	77	0	0	0	122	56	0	139	91	58	0	71	0	145	805	3,111	
5:15 PM	0	73	103	0	0	0	153	37	0	145	116	55	0	59	0	134	875	3,289	
5:30 PM	0	50	80	0	0	0	133	53	0	125	95	52	0	53	0	129	770	3,254	
5:45 PM	0	50	86	0	0	0	109	42	0	135	88	64	0	42	0	104	720	3,170	
Count Total	1	475	689	0	0	0	951	371	0	949	776	440	0	467	0	1,108	6,227	0	
Peak Hour	All	1	260	350	0	0	0	497	192	0	500	412	251	0	249	0	577	3,289	0
	HV	0	3	6	0	0	0	2	0	0	0	4	2	0	2	0	5	24	0
	HV%	0%	1%	2%	-	-	-	0%	0%	-	0%	1%	1%	-	1%	-	1%	1%	0

Note: Two-hour count summary volumes include heavy vehicles but exclude bicycles in overall count.

Interval Start	Heavy Vehicle Totals					Bicycles					Pedestrians (Crossing Leg)				
	EB	WB	NB	SB	Total	EB	WB	NB	SB	Total	East	West	North	South	Total
4:00 PM	0	3	1	4	8	0	1	0	0	1	1	0	2	3	6
4:15 PM	0	1	1	0	2	1	2	0	0	3	2	0	1	1	4
4:30 PM	2	0	2	1	5	0	2	1	0	3	2	0	0	0	2
4:45 PM	2	0	1	2	5	1	2	0	0	3	2	0	1	0	3
5:00 PM	1	2	2	3	8	1	2	0	0	3	3	0	2	0	5
5:15 PM	4	0	1	1	6	0	3	0	0	3	1	0	0	1	2
5:30 PM	1	0	2	1	4	0	3	0	1	4	0	0	1	2	3
5:45 PM	5	0	1	1	7	0	8	0	0	8	1	0	1	0	2
Count Total	15	6	11	13	45	3	23	1	1	28	12	0	8	7	27
Peak Hour	9	2	6	7	24	2	9	1	0	12	8	0	3	1	12

<b>Two-Hour Count Summaries - Heavy Vehicles</b>																			
Interval Start	Old Redwood Hwy				Old Redwood Hwy				US-101 NB Ramps				Lakewood Dr				15-min Total	Rolling One Hour	
	Eastbound				Westbound				Northbound				Southbound						
	UT	LT	TH	RT	UT	LT	TH	RT	UT	LT	TH	RT	UT	LT	TH	RT			
4:00 PM	0	0	0	0	0	0	3	0	0	1	0	0	0	0	0	0	4	8	0
4:15 PM	0	0	0	0	0	0	1	0	0	0	1	0	0	0	0	0	0	2	0
4:30 PM	0	0	2	0	0	0	0	0	0	0	2	0	0	1	0	0	0	5	0
4:45 PM	0	1	1	0	0	0	0	0	0	0	1	0	0	1	0	1	0	5	20
5:00 PM	0	0	1	0	0	0	2	0	0	0	0	2	0	0	0	3	0	8	20
5:15 PM	0	2	2	0	0	0	0	0	0	0	1	0	0	0	0	1	0	6	24
5:30 PM	0	1	0	0	0	0	0	0	0	0	2	0	0	0	0	1	0	4	23
5:45 PM	0	1	4	0	0	0	0	0	0	0	0	1	0	0	0	1	0	7	25
Count Total	0	5	10	0	0	0	6	0	0	1	7	3	0	2	0	11	0	45	0
Peak Hour	0	3	6	0	0	0	2	0	0	0	4	2	0	2	0	5	0	24	0
<b>Two-Hour Count Summaries - Bikes</b>																			
Interval Start	Old Redwood Hwy			Old Redwood Hwy			US-101 NB Ramps			Lakewood Dr			15-min Total	Rolling One Hour					
	Eastbound			Westbound			Northbound			Southbound									
	LT	TH	RT	LT	TH	RT	LT	TH	RT	LT	TH	RT							
4:00 PM	0	0	0	0	1	0	0	0	0	0	0	0	0	0	0	0	1	0	
4:15 PM	0	1	0	0	2	0	0	0	0	0	0	0	0	0	0	0	3	0	
4:30 PM	0	0	0	0	2	0	0	1	0	0	0	0	0	0	0	0	3	0	
4:45 PM	0	1	0	0	2	0	0	0	0	0	0	0	0	0	0	0	3	10	
5:00 PM	0	1	0	0	2	0	0	0	0	0	0	0	0	0	0	0	3	12	
5:15 PM	0	0	0	0	3	0	0	0	0	0	0	0	0	0	0	0	3	12	
5:30 PM	0	0	0	0	3	0	0	0	0	0	0	0	0	0	1	0	4	13	
5:45 PM	0	0	0	0	8	0	0	0	0	0	0	0	0	0	0	0	8	18	
Count Total	0	3	0	0	23	0	0	1	0	0	0	0	0	0	1	0	28	0	
Peak Hour	0	2	0	0	9	0	0	1	0	0	0	0	0	0	0	0	12	0	
<i>Note: U-Turn volumes for bikes are included in Left-Turn, if any.</i>																			

# US-101 NB On-Ramp Old Redwood Hwy



Date: 07/28/2022

Count Period: 4:00 PM to 6:00 PM

Peak Hour: 4:30 PM to 5:30 PM

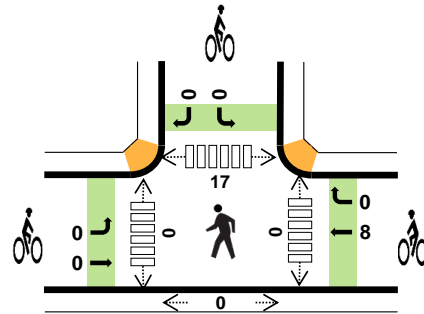
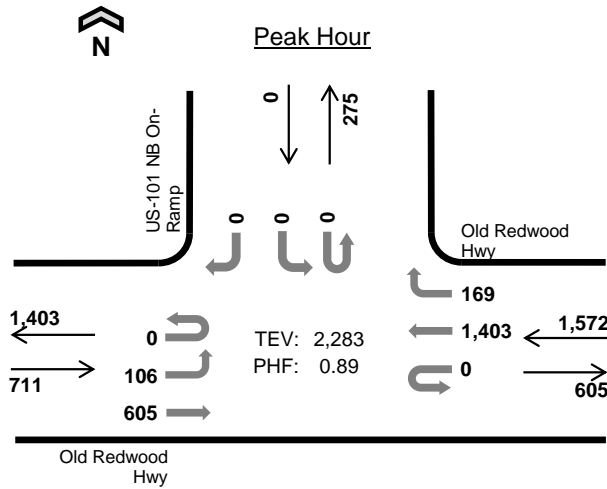

	HV %:	PHF
EB	0.8%	0.85
WB	0.6%	0.91
NB	-	-
SB	-	-
TOTAL	0.7%	0.89

### Two-Hour Count Summaries

Interval Start	Old Redwood Hwy Eastbound				Old Redwood Hwy Westbound				N/A Northbound				US-101 NB On-Ramp Southbound				15-min Total	Rolling One Hour
	UT	LT	TH	RT	UT	LT	TH	RT	UT	LT	TH	RT	UT	LT	TH	RT		
4:00 PM	0	20	160	0	0	0	328	30	0	0	0	0	0	0	0	0	538	0
4:15 PM	0	25	132	0	0	0	314	32	0	0	0	0	0	0	0	0	503	0
4:30 PM	0	29	157	0	0	0	317	54	0	0	0	0	0	0	0	0	557	0
4:45 PM	0	26	150	0	0	0	331	34	0	0	0	0	0	0	0	0	541	2,139
5:00 PM	0	20	121	0	0	0	367	39	0	0	0	0	0	0	0	0	547	2,148
5:15 PM	0	31	177	0	0	0	388	42	0	0	0	0	0	0	0	0	638	2,283
5:30 PM	0	19	129	0	0	0	331	47	0	0	0	0	0	0	0	0	526	2,252
5:45 PM	0	17	142	0	0	0	313	39	0	0	0	0	0	0	0	0	511	2,222
Count Total	0	187	1,168	0	0	0	2,689	317	0	0	0	0	0	0	0	0	4,361	0
Peak Hour	All	0	106	605	0	0	0	1,403	169	0	0	0	0	0	0	0	2,283	0
	HV	0	0	6	0	0	0	8	1	0	0	0	0	0	0	0	15	0
	HV%	-	0%	1%	-	-	-	1%	1%	-	-	-	-	-	-	-	1%	0

Note: Two-hour count summary volumes include heavy vehicles but exclude bicycles in overall count.

Interval Start	Heavy Vehicle Totals					Bicycles					Pedestrians (Crossing Leg)				
	EB	WB	NB	SB	Total	EB	WB	NB	SB	Total	East	West	North	South	Total
4:00 PM	1	8	0	0	9	0	1	0	0	1	0	0	3	1	4
4:15 PM	0	1	0	0	1	0	2	0	0	2	0	0	1	0	1
4:30 PM	2	0	0	0	2	0	2	0	0	2	0	0	0	0	0
4:45 PM	1	1	0	0	2	0	2	0	0	2	0	0	8	0	8
5:00 PM	0	7	0	0	7	0	2	0	0	2	0	0	6	0	6
5:15 PM	3	1	0	0	4	0	2	0	0	2	0	0	3	0	3
5:30 PM	1	2	0	0	3	0	5	0	0	5	0	0	4	0	4
5:45 PM	4	1	0	0	5	0	11	0	0	11	0	0	8	0	8
Count Total	12	21	0	0	33	0	27	0	0	27	0	0	33	1	34
Peak Hr	6	9	0	0	15	0	8	0	0	8	0	0	17	0	17

<b>Two-Hour Count Summaries - Heavy Vehicles</b>																		
Interval Start	Old Redwood Hwy				Old Redwood Hwy				N/A				US-101 NB On-Ramp				15-min Total	Rolling One Hour
	Eastbound				Westbound				Northbound				Southbound					
	UT	LT	TH	RT	UT	LT	TH	RT	UT	LT	TH	RT	UT	LT	TH	RT		
4:00 PM	0	1	0	0	0	0	8	0	0	0	0	0	0	0	0	9	0	
4:15 PM	0	0	0	0	0	0	0	1	0	0	0	0	0	0	0	1	0	
4:30 PM	0	0	2	0	0	0	0	0	0	0	0	0	0	0	0	2	0	
4:45 PM	0	0	1	0	0	0	1	0	0	0	0	0	0	0	0	2	14	
5:00 PM	0	0	0	0	0	0	6	1	0	0	0	0	0	0	0	7	12	
5:15 PM	0	0	3	0	0	0	1	0	0	0	0	0	0	0	0	4	15	
5:30 PM	0	0	1	0	0	0	2	0	0	0	0	0	0	0	0	3	16	
5:45 PM	0	0	4	0	0	0	1	0	0	0	0	0	0	0	0	5	19	
Count Total	0	1	11	0	0	0	19	2	0	0	0	0	0	0	0	33	0	
Peak Hour	0	0	6	0	0	0	8	1	0	0	0	0	0	0	0	15	0	
<b>Two-Hour Count Summaries - Bikes</b>																		
Interval Start	Old Redwood Hwy			Old Redwood Hwy			N/A			US-101 NB On-Ramp			15-min Total	Rolling One Hour				
	Eastbound			Westbound			Northbound			Southbound								
	LT	TH	RT	LT	TH	RT	LT	TH	RT	LT	TH	RT						
4:00 PM	0	0	0	0	1	0	0	0	0	0	0	0	1	0				
4:15 PM	0	0	0	0	2	0	0	0	0	0	0	0	2	0				
4:30 PM	0	0	0	0	2	0	0	0	0	0	0	0	2	0				
4:45 PM	0	0	0	0	2	0	0	0	0	0	0	0	2	7				
5:00 PM	0	0	0	0	2	0	0	0	0	0	0	0	2	8				
5:15 PM	0	0	0	0	2	0	0	0	0	0	0	0	2	8				
5:30 PM	0	0	0	0	4	1	0	0	0	0	0	0	5	11				
5:45 PM	0	0	0	0	11	0	0	0	0	0	0	0	11	20				
Count Total	0	0	0	0	26	1	0	0	0	0	0	0	27	0				
Peak Hour	0	0	0	0	8	0	0	0	0	0	0	0	8	0				
Note: U-Turn volumes for bikes are included in Left-Turn, if any.																		



# US-101 SB Ramps Old Redwood Hwy



Date: 07/28/2022  
 Count Period: 4:00 PM to 6:00 PM  
 Peak Hour: 4:30 PM to 5:30 PM

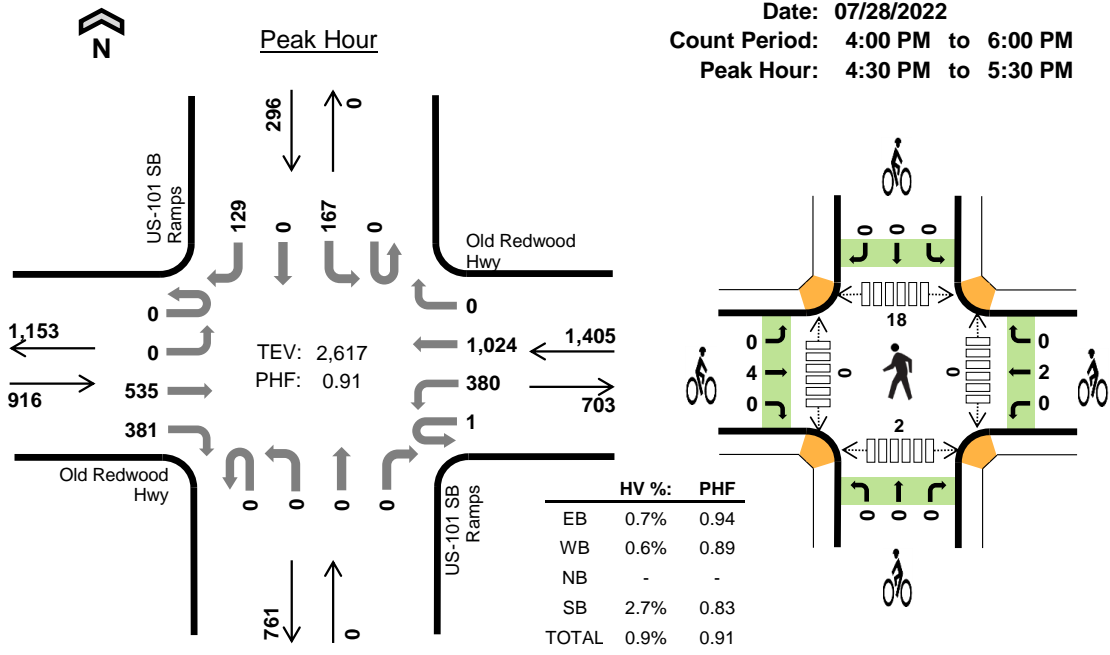

### Two-Hour Count Summaries

Interval Start	Old Redwood Hwy Eastbound				Old Redwood Hwy Westbound				US-101 SB Ramps Northbound				US-101 SB Ramps Southbound				15-min Total	Rolling One Hour	
	UT	LT	TH	RT	UT	LT	TH	RT	UT	LT	TH	RT	UT	LT	TH	RT			
	4:00 PM	0	0	127	76	0	103	222	0	0	0	0	0	0	54	0			33
4:15 PM	0	0	111	66	0	94	229	0	0	0	0	0	0	40	1	42	583	0	
4:30 PM	0	0	142	84	0	92	228	0	0	0	0	0	0	43	0	20	609	0	
4:45 PM	0	0	137	107	0	93	233	0	0	0	0	0	0	40	0	40	650	2,457	
5:00 PM	0	0	108	101	0	88	278	0	0	0	0	0	0	35	0	29	639	2,481	
5:15 PM	0	0	148	89	1	107	285	0	0	0	0	0	0	49	0	40	719	2,617	
5:30 PM	0	0	136	77	0	85	253	0	0	0	0	0	0	22	0	33	606	2,614	
5:45 PM	0	0	119	79	1	60	242	0	0	0	0	0	0	37	0	22	560	2,524	
Count Total	0	0	1,028	679	2	722	1,970	0	0	0	0	0	0	320	1	259	4,981	0	
Peak Hour	All	0	0	535	381	1	380	1,024	0	0	0	0	0	0	167	0	129	2,617	0
	HV	0	0	3	3	0	3	6	0	0	0	0	0	0	5	0	3	23	0
	HV%	-	-	1%	1%	0%	1%	1%	-	-	-	-	-	-	3%	-	2%	1%	0

Note: Two-hour count summary volumes include heavy vehicles but exclude bicycles in overall count.

Interval Start	Heavy Vehicle Totals					Bicycles					Pedestrians (Crossing Leg)					
	EB	WB	NB	SB	Total	EB	WB	NB	SB	Total	East	West	North	South	Total	
4:00 PM	3	7	0	2	12	0	0	0	0	0	0	0	0	1	3	4
4:15 PM	2	1	0	2	5	1	1	0	0	2	0	0	0	0	0	
4:30 PM	1	1	0	2	4	0	0	0	0	0	0	0	1	2	3	
4:45 PM	1	2	0	2	5	1	0	0	0	1	0	0	5	0	5	
5:00 PM	0	3	0	3	6	1	2	0	0	3	0	0	5	0	5	
5:15 PM	4	3	0	1	8	2	0	0	0	2	0	0	7	0	7	
5:30 PM	3	1	0	0	4	0	4	0	0	4	0	0	9	2	11	
5:45 PM	4	2	0	0	6	1	13	0	0	14	0	0	28	0	28	
Count Total	18	20	0	12	50	6	20	0	0	26	0	0	56	7	63	
Peak Hour	6	9	0	8	23	4	2	0	0	6	0	0	18	2	20	

<b>Two-Hour Count Summaries - Heavy Vehicles</b>																		
Interval Start	Old Redwood Hwy				Old Redwood Hwy				US-101 SB Ramps				US-101 SB Ramps				15-min Total	Rolling One Hour
	Eastbound				Westbound				Northbound				Southbound					
	UT	LT	TH	RT	UT	LT	TH	RT	UT	LT	TH	RT	UT	LT	TH	RT		
4:00 PM	0	0	1	2	0	3	4	0	0	0	0	0	0	0	0	2	12	0
4:15 PM	0	0	1	1	0	1	0	0	0	0	0	0	0	0	0	1	5	0
4:30 PM	0	0	0	1	0	0	1	0	0	0	0	0	0	0	2	0	4	0
4:45 PM	0	0	0	1	0	1	1	0	0	0	0	0	0	0	1	0	5	26
5:00 PM	0	0	0	0	0	1	2	0	0	0	0	0	0	0	1	0	6	20
5:15 PM	0	0	3	1	0	1	2	0	0	0	0	0	0	0	1	0	8	23
5:30 PM	0	0	3	0	0	0	1	0	0	0	0	0	0	0	0	0	4	23
5:45 PM	0	0	4	0	0	1	1	0	0	0	0	0	0	0	0	0	6	24
Count Total	0	0	12	6	0	8	12	0	0	0	0	0	0	5	1	6	50	0
Peak Hour	0	0	3	3	0	3	6	0	0	0	0	0	0	5	0	3	23	0
<b>Two-Hour Count Summaries - Bikes</b>																		
Interval Start	Old Redwood Hwy			Old Redwood Hwy			US-101 SB Ramps			US-101 SB Ramps			15-min Total	Rolling One Hour				
	Eastbound			Westbound			Northbound			Southbound								
	LT	TH	RT	LT	TH	RT	LT	TH	RT	LT	TH	RT						
4:00 PM	0	0	0	0	0	0	0	0	0	0	0	0	0	0	0	0	0	0
4:15 PM	0	1	0	0	1	0	0	0	0	0	0	0	0	0	0	0	2	0
4:30 PM	0	0	0	0	0	0	0	0	0	0	0	0	0	0	0	0	0	0
4:45 PM	0	1	0	0	0	0	0	0	0	0	0	0	0	0	0	0	1	3
5:00 PM	0	1	0	0	0	2	0	0	0	0	0	0	0	0	0	0	3	6
5:15 PM	0	2	0	0	0	0	0	0	0	0	0	0	0	0	0	0	2	6
5:30 PM	0	0	0	0	0	4	0	0	0	0	0	0	0	0	0	0	4	10
5:45 PM	0	1	0	0	0	13	0	0	0	0	0	0	0	0	0	0	14	23
Count Total	0	6	0	0	0	20	0	0	0	0	0	0	0	0	0	0	26	0
Peak Hour	0	4	0	0	0	2	0	0	0	0	0	0	0	0	0	0	6	0
<i>Note: U-Turn volumes for bikes are included in Left-Turn, if any.</i>																		

### Old Redwood Hwy Shiloh Rd



Date: 07/30/2022  
 Count Period: 10:00 AM to 4:00 PM  
 Peak Hour: 11:30 AM to 12:30 PM

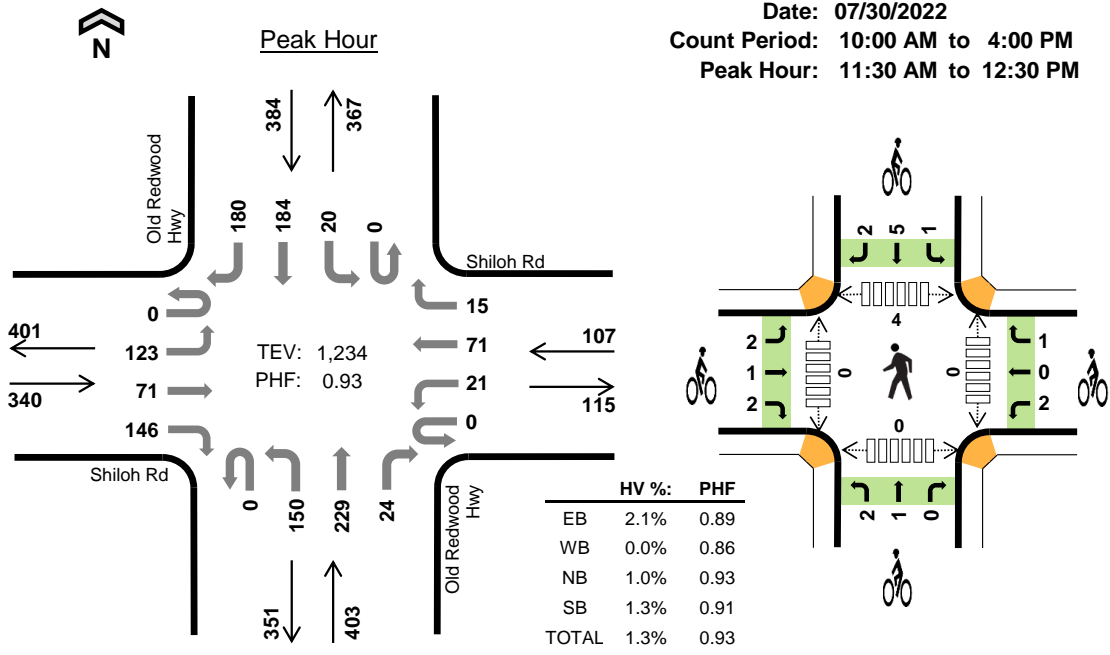

#### Six-Hour Count Summaries

Interval Start	Shiloh Rd				Shiloh Rd				Old Redwood Hwy				Old Redwood Hwy				15-min Total	Rolling One Hour	
	Eastbound		Westbound		Northbound		Southbound		Northbound		Southbound								
	UT	LT	TH	RT	UT	LT	TH	RT	UT	LT	TH	RT	UT	LT	TH	RT			
11:30 AM	0	24	16	43	0	4	19	2	0	34	55	5	0	5	46	47	300	0	
11:45 AM	0	28	18	35	0	11	15	2	0	40	60	8	0	5	37	36	295	0	
12:00 PM	0	45	22	29	0	2	23	6	0	37	55	8	0	7	49	50	333	0	
12:15 PM	0	26	15	39	0	4	14	5	0	39	59	3	0	3	52	47	306	1,234	
Peak Hour	All	0	123	71	146	0	21	71	15	0	150	229	24	0	20	184	180	1,234	0
	HV	0	2	0	5	0	0	0	0	0	1	3	0	0	0	2	3	16	0
	HV%	-	2%	0%	3%	-	0%	0%	0%	-	1%	1%	0%	-	0%	1%	2%	1%	0

Note: For all three-hour count summary, see next page.

Interval Start	Heavy Vehicle Totals					Bicycles					Pedestrians (Crossing Leg)				
	EB	WB	NB	SB	Total	EB	WB	NB	SB	Total	East	West	North	South	Total
11:30 AM	4	0	1	0	5	2	1	2	2	7	0	0	0	0	0
11:45 AM	2	0	1	2	5	0	2	1	5	8	0	0	4	0	4
12:00 PM	1	0	1	2	4	2	0	0	1	3	0	0	0	0	0
12:15 PM	0	0	1	1	2	1	0	0	0	1	0	0	0	0	0
Peak Hour	7	0	4	5	16	5	3	3	8	19	0	0	4	0	4

Six-Hour Count Summaries																			
Interval Start	Shiloh Rd				Shiloh Rd				Old Redwood Hwy				Old Redwood Hwy				15-min Total	Rolling One Hour	
	UT	Eastbound		RT	UT	Westbound		RT	UT	Northbound		RT	UT	Southbound		RT			
10:00 AM	0	31	16	31	0	6	14	3	0	24	32	1	0	4	50	32	244	0	
10:15 AM	0	19	17	42	0	5	25	6	0	28	48	5	0	3	47	28	273	0	
10:30 AM	0	19	22	48	0	3	15	6	0	26	39	4	0	2	60	31	275	0	
10:45 AM	0	22	22	27	0	4	17	3	0	36	45	3	0	5	47	44	275	1,067	
11:00 AM	0	20	24	28	0	7	16	5	0	38	44	4	0	6	50	33	275	1,098	
11:15 AM	0	28	10	45	0	4	16	4	0	33	42	3	0	4	47	34	270	1,095	
11:30 AM	0	24	16	43	0	4	19	2	0	34	55	5	0	5	46	47	300	1,120	
11:45 AM	0	28	18	35	0	11	15	2	0	40	60	8	0	5	37	36	295	1,140	
12:00 PM	0	45	22	29	0	2	23	6	0	37	55	8	0	7	49	50	333	1,198	
12:15 PM	0	26	15	39	0	4	14	5	0	39	59	3	0	3	52	47	306	1,234	
12:30 PM	0	32	24	30	0	2	21	6	0	36	47	4	0	2	39	42	285	1,219	
12:45 PM	0	33	11	36	0	1	21	9	0	35	42	4	0	2	51	33	278	1,202	
1:00 PM	0	41	28	39	0	4	19	5	0	35	49	4	0	2	46	33	305	1,174	
1:15 PM	0	45	22	36	0	2	18	9	0	32	41	8	0	3	63	29	308	1,176	
1:30 PM	0	27	21	41	0	5	17	5	0	33	38	4	0	4	44	38	277	1,168	
1:45 PM	0	30	21	33	0	5	24	3	0	42	47	11	0	4	57	24	301	1,191	
2:00 PM	0	29	23	39	0	5	21	6	0	28	57	4	0	11	38	33	294	1,180	
2:15 PM	1	36	16	24	0	7	18	3	0	33	47	2	1	5	53	35	281	1,153	
2:30 PM	0	34	25	43	0	3	19	4	0	35	47	1	0	1	35	33	280	1,156	
2:45 PM	0	33	15	29	0	4	21	4	0	33	40	0	0	6	46	35	266	1,121	
3:00 PM	0	40	16	40	0	6	20	2	0	28	41	4	0	2	46	37	282	1,109	
3:15 PM	0	39	13	40	0	3	22	3	0	27	45	5	0	6	47	22	272	1,100	
3:30 PM	0	33	11	30	0	2	20	4	0	32	46	1	0	4	46	28	257	1,077	
3:45 PM	0	28	17	21	0	4	33	2	0	25	52	5	0	2	32	32	253	1,064	
Count Total	1	742	445	848	0	103	468	107	0	789	1,118	101	1	98	1,128	836	6,785	0	
Peak Hour	All	0	123	71	146	0	21	71	15	0	150	229	24	0	20	184	180	1,234	0
	HV	0	2	0	5	0	0	0	0	0	1	3	0	0	0	2	3	16	0
	HV%	-	2%	0%	3%	-	0%	0%	0%	-	1%	1%	0%	-	0%	1%	2%	1%	0

Note: Six-hour count summary volumes include heavy vehicles but exclude bicycles in overall count.

Interval Start	Heavy Vehicle Totals					Bicycles					Pedestrians (Crossing Leg)				
	EB	WB	NB	SB	Total	EB	WB	NB	SB	Total	East	West	North	South	Total
10:00 AM	1	0	0	2	3	0	1	0	0	1	0	0	0	0	0
10:15 AM	0	0	3	3	6	0	0	5	2	7	0	0	1	0	1
10:30 AM	2	0	1	2	5	0	0	1	1	2	0	0	0	0	0
10:45 AM	1	0	0	1	2	1	0	1	0	2	2	0	0	0	2
11:00 AM	2	0	1	3	6	0	2	2	0	4	0	1	3	0	4
11:15 AM	0	0	1	1	2	0	0	0	3	3	0	0	2	0	2
11:30 AM	4	0	1	0	5	2	1	2	2	7	0	0	0	0	0
11:45 AM	2	0	1	2	5	0	2	1	5	8	0	0	4	0	4
12:00 PM	1	0	1	2	4	2	0	0	1	3	0	0	0	0	0
12:15 PM	0	0	1	1	2	1	0	0	0	1	0	0	0	0	0
12:30 PM	0	0	0	1	1	1	1	2	5	9	0	0	1	0	1
12:45 PM	1	0	0	2	3	1	0	1	1	3	0	0	0	0	0
1:00 PM	2	0	3	0	5	2	0	1	1	4	0	0	0	0	0
1:15 PM	1	1	4	1	7	0	0	0	2	2	0	0	0	0	0
1:30 PM	1	0	2	3	6	0	0	0	5	5	0	0	0	0	0
1:45 PM	3	0	1	2	6	0	0	1	0	1	0	0	0	0	0
2:00 PM	2	0	1	1	4	1	0	2	0	3	0	0	0	0	0
2:15 PM	0	0	1	1	2	0	0	2	0	2	0	0	0	0	0
2:30 PM	1	0	1	2	4	0	0	0	1	1	0	0	0	0	0
2:45 PM	0	0	1	2	3	0	1	1	0	2	0	0	0	0	0
3:00 PM	2	0	2	0	4	0	0	0	3	3	0	0	1	0	1
3:15 PM	1	0	1	1	3	0	0	1	2	3	0	0	0	0	0
3:30 PM	1	0	1	2	4	0	0	0	0	0	0	0	0	0	0
3:45 PM	0	0	0	0	0	0	0	0	0	0	0	0	0	0	0
Count Total	28	1	28	35	92	11	8	23	34	76	2	1	12	0	15
Peak Hour	7	0	4	5	16	5	3	3	8	19	0	0	4	0	4

Six-Hour Count Summaries - Heavy Vehicles																		
Interval Start	Shiloh Rd				Shiloh Rd				Old Redwood Hwy				Old Redwood Hwy				15-min Total	Rolling One Hour
	Eastbound				Westbound				Northbound				Southbound					
	UT	LT	TH	RT	UT	LT	TH	RT	UT	LT	TH	RT	UT	LT	TH	RT		
10:00 AM	0	0	0	1	0	0	0	0	0	0	0	0	0	0	0	2	3	0
10:15 AM	0	0	0	0	0	0	0	0	0	1	2	0	0	0	1	2	6	0
10:30 AM	0	1	0	1	0	0	0	0	0	0	1	0	0	0	1	1	5	0
10:45 AM	0	0	0	1	0	0	0	0	0	0	0	0	0	0	0	1	2	16
11:00 AM	0	0	0	2	0	0	0	0	0	1	0	0	0	0	1	2	6	19
11:15 AM	0	0	0	0	0	0	0	0	0	1	0	0	0	0	0	1	2	15
11:30 AM	0	1	0	3	0	0	0	0	0	0	1	0	0	0	0	0	5	15
11:45 AM	0	1	0	1	0	0	0	0	0	1	0	0	0	0	1	1	5	18
12:00 PM	0	0	0	1	0	0	0	0	0	0	1	0	0	0	0	2	4	16
12:15 PM	0	0	0	0	0	0	0	0	0	0	1	0	0	0	1	0	2	16
12:30 PM	0	0	0	0	0	0	0	0	0	0	0	0	0	0	0	1	1	12
12:45 PM	0	0	0	1	0	0	0	0	0	0	0	0	0	0	1	1	3	10
1:00 PM	0	1	0	1	0	0	0	0	0	1	2	0	0	0	0	0	5	11
1:15 PM	0	1	0	0	0	0	0	1	0	2	2	0	0	0	1	0	7	16
1:30 PM	0	1	0	0	0	0	0	0	0	1	1	0	0	0	2	1	6	21
1:45 PM	0	0	1	2	0	0	0	0	0	1	0	0	0	0	2	0	6	24
2:00 PM	0	1	0	1	0	0	0	0	0	0	1	0	0	0	0	1	4	23
2:15 PM	0	0	0	0	0	0	0	0	0	0	1	0	0	0	1	0	2	18
2:30 PM	0	0	0	1	0	0	0	0	0	0	1	0	0	0	0	2	4	16
2:45 PM	0	0	0	0	0	0	0	0	0	0	1	0	0	0	2	0	3	13
3:00 PM	0	1	0	1	0	0	0	0	0	2	0	0	0	0	0	0	4	13
3:15 PM	0	0	0	1	0	0	0	0	0	1	0	0	0	0	1	0	3	14
3:30 PM	0	0	0	1	0	0	0	0	0	1	0	0	0	0	1	1	4	14
3:45 PM	0	0	0	0	0	0	0	0	0	0	0	0	0	0	0	0	0	11
Count Total	0	8	1	19	0	0	0	1	0	13	15	0	0	0	16	19	92	0
Peak Hour	0	2	0	5	0	0	0	0	0	1	3	0	0	0	2	3	16	0

Six-Hour Count Summaries - Bikes

Interval Start	Shiloh Rd			Shiloh Rd			Old Redwood Hwy			Old Redwood Hwy			15-min Total	Rolling One Hour		
	Eastbound			Westbound			Northbound			Southbound						
	LT	TH	RT	LT	TH	RT	LT	TH	RT	LT	TH	RT				
10:00 AM	0	0	0	1	0	0	0	0	0	0	0	0	1	0		
10:15 AM	0	0	0	0	0	0	0	2	3	0	0	2	0	7	0	
10:30 AM	0	0	0	0	0	0	0	0	1	0	0	1	0	2	0	
10:45 AM	0	1	0	0	0	0	0	1	0	0	0	0	0	2	12	
11:00 AM	0	0	0	0	2	0	0	0	2	0	0	0	0	4	15	
11:15 AM	0	0	0	0	0	0	0	0	0	0	0	3	0	3	11	
11:30 AM	0	1	1	0	0	1	0	2	0	0	0	2	0	7	16	
11:45 AM	0	0	0	2	0	0	0	0	1	0	0	1	2	2	8	22
12:00 PM	2	0	0	0	0	0	0	0	0	0	0	1	0	3	21	
12:15 PM	0	0	1	0	0	0	0	0	0	0	0	0	0	1	19	
12:30 PM	0	1	0	0	1	0	0	0	1	1	0	5	0	9	21	
12:45 PM	0	0	1	0	0	0	0	1	0	0	1	0	0	3	16	
1:00 PM	0	1	1	0	0	0	0	0	1	0	0	1	0	4	17	
1:15 PM	0	0	0	0	0	0	0	0	0	0	0	2	0	2	18	
1:30 PM	0	0	0	0	0	0	0	0	0	0	0	5	0	5	14	
1:45 PM	0	0	0	0	0	0	0	1	0	0	0	0	0	1	12	
2:00 PM	0	1	0	0	0	0	0	1	1	0	0	0	0	3	11	
2:15 PM	0	0	0	0	0	0	0	0	0	2	0	0	0	2	11	
2:30 PM	0	0	0	0	0	0	0	0	0	0	0	0	1	1	7	
2:45 PM	0	0	0	0	1	0	0	1	0	0	0	0	0	2	8	
3:00 PM	0	0	0	0	0	0	0	0	0	0	3	0	0	3	8	
3:15 PM	0	0	0	0	0	0	0	0	1	0	0	2	0	3	9	
3:30 PM	0	0	0	0	0	0	0	0	0	0	0	0	0	0	8	
3:45 PM	0	0	0	0	0	0	0	0	0	0	0	0	0	0	6	
Count Total	2	5	4	3	4	1	0	9	11	3	5	26	3	76	0	
Peak Hour	2	1	2	2	0	1	0	2	1	0	1	5	2	19	0	

Note: U-Turn volumes for bikes are included in Left-Turn, if any.

### Hembree Ln Shiloh Rd



Date: 07/30/2022  
 Count Period: 10:00 AM to 4:00 PM  
 Peak Hour: 12:45 PM to 1:45 PM

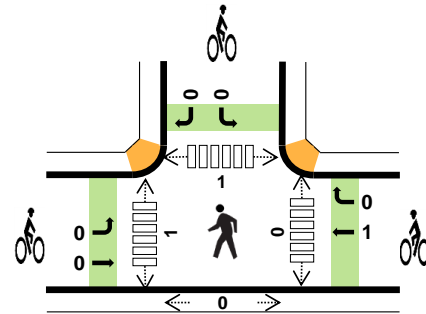
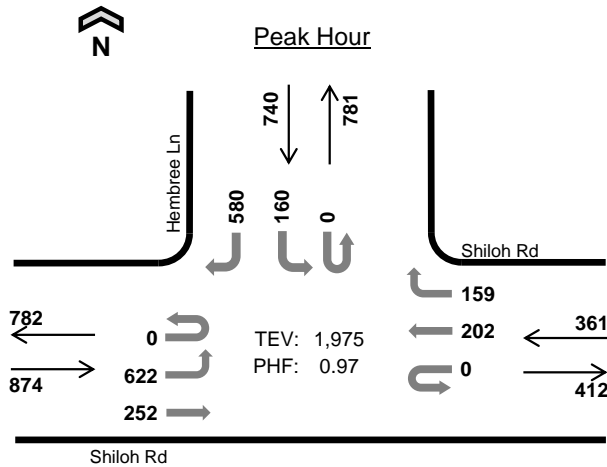

	HV %:	PHF
EB	1.4%	0.94
WB	2.2%	0.96
NB	-	-
SB	0.8%	0.91
TOTAL	1.3%	0.97

#### Six-Hour Count Summaries

Interval Start	Shiloh Rd Eastbound				Shiloh Rd Westbound				n/a Northbound				Hembree Ln Southbound				15-min Total	Rolling One Hour	
	UT	LT	TH	RT	UT	LT	TH	RT	UT	LT	TH	RT	UT	LT	TH	RT			
	12:45 PM	0	159	50	0	0	0	44	50	0	0	0	0	0	44	0			137
1:00 PM	0	138	75	0	0	0	50	41	0	0	0	0	0	39	0	146	489	0	
1:15 PM	0	161	72	0	0	0	54	33	0	0	0	0	0	37	0	134	491	0	
1:30 PM	0	164	55	0	0	0	54	35	0	0	0	0	0	40	0	163	511	1,975	
Peak Hour	All	0	622	252	0	0	0	202	159	0	0	0	0	0	160	0	580	1,975	0
	HV	0	9	3	0	0	0	4	4	0	0	0	0	0	3	0	3	26	0
	HV%	-	1%	1%	-	-	-	2%	3%	-	-	-	-	-	2%	-	1%	1%	0

Note: For all three-hour count summary, see next page.

Interval Start	Heavy Vehicle Totals					Bicycles					Pedestrians (Crossing Leg)				
	EB	WB	NB	SB	Total	EB	WB	NB	SB	Total	East	West	North	South	Total
12:45 PM	3	1	0	2	6	0	1	0	0	1	0	0	1	0	1
1:00 PM	3	1	0	3	7	0	0	0	0	0	0	1	0	0	1
1:15 PM	3	4	0	0	7	0	0	0	0	0	0	0	0	0	0
1:30 PM	3	2	0	1	6	0	0	0	0	0	0	0	0	0	0
Peak Hour	12	8	0	6	26	0	1	0	0	1	0	1	1	0	2

Six-Hour Count Summaries																			
Interval Start	Shiloh Rd				Shiloh Rd				n/a				Hembree Ln				15-min Total	Rolling One Hour	
	Eastbound				Westbound				Northbound				Southbound						
	UT	LT	TH	RT	UT	LT	TH	RT	UT	LT	TH	RT	UT	LT	TH	RT			
10:00 AM	0	124	45	0	0	0	50	33	0	0	0	0	0	32	0	97	381	0	
10:15 AM	0	119	52	0	1	0	45	36	0	0	0	0	0	37	0	87	377	0	
10:30 AM	0	125	60	0	0	0	54	25	0	0	0	0	0	28	0	110	402	0	
10:45 AM	0	121	46	0	0	0	61	32	0	0	0	0	0	25	0	95	380	1,540	
11:00 AM	0	113	50	0	0	0	50	36	0	0	0	0	0	29	0	126	404	1,563	
11:15 AM	0	125	52	0	0	0	59	28	0	0	0	0	0	32	0	130	426	1,612	
11:30 AM	0	155	52	0	0	0	56	48	0	0	0	0	0	40	0	112	463	1,673	
11:45 AM	0	139	59	0	0	0	50	41	0	0	0	0	0	26	0	132	447	1,740	
12:00 PM	0	142	58	0	0	0	66	46	0	0	0	0	0	35	0	125	472	1,808	
12:15 PM	0	133	42	0	0	0	57	47	0	0	0	0	0	52	0	145	476	1,858	
12:30 PM	0	160	49	0	0	0	61	45	0	0	0	0	0	35	0	149	499	1,894	
12:45 PM	0	159	50	0	0	0	44	50	0	0	0	0	0	44	0	137	484	1,931	
1:00 PM	0	138	75	0	0	0	50	41	0	0	0	0	0	39	0	146	489	1,948	
1:15 PM	0	161	72	0	0	0	54	33	0	0	0	0	0	37	0	134	491	1,963	
1:30 PM	0	164	55	0	0	0	54	35	0	0	0	0	0	40	0	163	511	1,975	
1:45 PM	0	164	44	0	0	0	56	43	0	0	0	0	1	38	0	131	477	1,968	
2:00 PM	0	146	59	0	0	0	49	32	0	0	0	0	0	36	0	146	468	1,947	
2:15 PM	0	156	58	0	0	0	58	37	0	0	0	0	0	29	0	131	469	1,925	
2:30 PM	0	143	63	0	0	0	49	36	0	0	0	0	0	44	0	135	470	1,884	
2:45 PM	0	149	52	0	0	0	50	35	0	0	0	0	0	30	0	126	442	1,849	
3:00 PM	0	159	56	0	0	0	47	37	0	0	0	0	0	47	0	132	478	1,859	
3:15 PM	0	135	57	0	0	0	47	35	0	0	0	0	0	36	0	140	450	1,840	
3:30 PM	0	125	48	0	0	0	43	35	0	0	0	0	0	29	0	146	426	1,796	
3:45 PM	0	115	44	0	0	0	62	29	0	0	0	0	0	33	0	125	408	1,762	
Count Total	0	3,370	1,298	0	1	0	1,272	895	0	0	0	0	1	853	0	3,100	10,790	0	
Peak Hour	All	0	622	252	0	0	0	202	159	0	0	0	0	0	160	0	580	1,975	0
	HV	0	9	3	0	0	0	4	4	0	0	0	0	0	3	0	3	26	0
	HV%	-	1%	1%	-	-	-	2%	3%	-	-	-	-	-	2%	-	1%	1%	0

Note: Six-hour count summary volumes include heavy vehicles but exclude bicycles in overall count.

Interval Start	Heavy Vehicle Totals					Bicycles					Pedestrians (Crossing Leg)				
	EB	WB	NB	SB	Total	EB	WB	NB	SB	Total	East	West	North	South	Total
10:00 AM	1	2	0	2	5	0	2	0	0	2	0	0	0	0	0
10:15 AM	3	3	0	3	9	0	1	0	0	1	0	0	2	0	2
10:30 AM	5	2	0	3	10	0	0	0	0	0	0	0	0	0	0
10:45 AM	1	1	0	2	4	0	1	0	0	1	0	0	0	0	0
11:00 AM	0	2	0	1	3	2	0	0	0	2	0	0	0	0	0
11:15 AM	1	3	0	1	5	0	2	0	0	2	0	0	2	0	2
11:30 AM	3	0	0	5	8	1	0	0	0	1	0	0	0	0	0
11:45 AM	5	2	0	0	7	0	4	0	0	4	0	0	3	0	3
12:00 PM	3	2	0	2	7	0	0	0	0	0	0	0	0	0	0
12:15 PM	2	1	0	1	4	0	1	0	1	2	0	0	0	0	0
12:30 PM	1	1	0	4	6	1	1	0	0	2	0	0	1	0	1
12:45 PM	3	1	0	2	6	0	1	0	0	1	0	0	1	0	1
1:00 PM	3	1	0	3	7	0	0	0	0	0	0	1	0	0	1
1:15 PM	3	4	0	0	7	0	0	0	0	0	0	0	0	0	0
1:30 PM	3	2	0	1	6	0	0	0	0	0	0	0	0	0	0
1:45 PM	3	1	0	2	6	0	0	0	0	0	0	0	0	0	0
2:00 PM	1	1	0	2	4	0	1	0	0	1	0	0	0	0	0
2:15 PM	4	0	0	0	4	0	0	0	0	0	0	0	0	0	0
2:30 PM	1	2	0	3	6	0	0	0	0	0	0	0	0	0	0
2:45 PM	0	0	0	3	3	1	1	0	0	2	0	0	1	0	1
3:00 PM	3	2	0	3	8	0	1	0	0	1	0	0	1	0	1
3:15 PM	0	1	0	3	4	0	0	0	0	0	0	0	0	0	0
3:30 PM	4	3	0	1	8	0	0	0	0	0	0	0	0	0	0
3:45 PM	1	0	0	0	1	0	0	0	0	0	0	0	0	0	0
Count Total	54	37	0	47	138	5	16	0	1	22	0	1	11	0	12
Peak Hr	12	8	0	6	26	0	1	0	0	1	0	1	1	0	2

Six-Hour Count Summaries - Heavy Vehicles																		
Interval Start	Shiloh Rd				Shiloh Rd				n/a				Hembree Ln				15-min Total	Rolling One Hour
	Eastbound				Westbound				Northbound				Southbound					
	UT	LT	TH	RT	UT	LT	TH	RT	UT	LT	TH	RT	UT	LT	TH	RT		
10:00 AM	0	1	0	0	0	0	1	1	0	0	0	0	0	2	0	0	5	0
10:15 AM	0	3	0	0	0	0	3	0	0	0	0	0	0	0	0	3	9	0
10:30 AM	0	3	2	0	0	0	2	0	0	0	0	0	0	0	0	3	10	0
10:45 AM	0	1	0	0	0	0	1	0	0	0	0	0	0	1	0	1	4	28
11:00 AM	0	0	0	0	0	0	2	0	0	0	0	0	0	1	0	0	3	26
11:15 AM	0	1	0	0	0	0	0	3	0	0	0	0	0	0	0	1	5	22
11:30 AM	0	2	1	0	0	0	0	0	0	0	0	0	0	3	0	2	8	20
11:45 AM	0	3	2	0	0	0	0	2	0	0	0	0	0	0	0	0	7	23
12:00 PM	0	3	0	0	0	0	2	0	0	0	0	0	0	1	0	1	7	27
12:15 PM	0	1	1	0	0	0	1	0	0	0	0	0	0	0	0	1	4	26
12:30 PM	0	0	1	0	0	0	0	1	0	0	0	0	0	0	0	4	6	24
12:45 PM	0	3	0	0	0	0	0	1	0	0	0	0	0	1	0	1	6	23
1:00 PM	0	2	1	0	0	0	0	1	0	0	0	0	0	1	0	2	7	23
1:15 PM	0	2	1	0	0	0	3	1	0	0	0	0	0	0	0	0	7	26
1:30 PM	0	2	1	0	0	0	1	1	0	0	0	0	0	1	0	0	6	26
1:45 PM	0	2	1	0	0	0	0	1	0	0	0	0	0	1	0	1	6	26
2:00 PM	0	1	0	0	0	0	0	1	0	0	0	0	0	2	0	0	4	23
2:15 PM	0	4	0	0	0	0	0	0	0	0	0	0	0	0	0	0	4	20
2:30 PM	0	1	0	0	0	0	2	0	0	0	0	0	0	1	0	2	6	20
2:45 PM	0	0	0	0	0	0	0	0	0	0	0	0	0	0	0	3	3	17
3:00 PM	0	1	2	0	0	0	1	1	0	0	0	0	0	2	0	1	8	21
3:15 PM	0	0	0	0	0	0	1	0	0	0	0	0	0	0	0	3	4	21
3:30 PM	0	4	0	0	0	0	1	2	0	0	0	0	0	1	0	0	8	23
3:45 PM	0	1	0	0	0	0	0	0	0	0	0	0	0	0	0	0	1	21
Count Total	0	41	13	0	0	0	21	16	0	0	0	0	0	18	0	29	138	0
Peak Hour	0	9	3	0	0	0	4	4	0	0	0	0	0	3	0	3	26	0

Six-Hour Count Summaries - Bikes																
Interval Start	Shiloh Rd			Shiloh Rd			n/a			Hembree Ln			15-min Total	Rolling One Hour		
	Eastbound			Westbound			Northbound			Southbound						
	LT	TH	RT	LT	TH	RT	LT	TH	RT	LT	TH	RT				
10:00 AM	0	0	0	0	2	0	0	0	0	0	0	0	2	0		
10:15 AM	0	0	0	0	1	0	0	0	0	0	0	0	1	0		
10:30 AM	0	0	0	0	0	0	0	0	0	0	0	0	0	0		
10:45 AM	0	0	0	0	1	0	0	0	0	0	0	0	1	4		
11:00 AM	1	1	0	0	0	0	0	0	0	0	0	0	2	4		
11:15 AM	0	0	0	0	2	0	0	0	0	0	0	0	2	5		
11:30 AM	0	1	0	0	0	0	0	0	0	0	0	0	1	6		
11:45 AM	0	0	0	0	3	1	0	0	0	0	0	0	4	9		
12:00 PM	0	0	0	0	0	0	0	0	0	0	0	0	0	7		
12:15 PM	0	0	0	0	0	1	0	0	0	0	1	0	2	7		
12:30 PM	0	1	0	0	1	0	0	0	0	0	0	0	2	8		
12:45 PM	0	0	0	0	1	0	0	0	0	0	0	0	1	5		
1:00 PM	0	0	0	0	0	0	0	0	0	0	0	0	0	5		
1:15 PM	0	0	0	0	0	0	0	0	0	0	0	0	0	3		
1:30 PM	0	0	0	0	0	0	0	0	0	0	0	0	0	1		
1:45 PM	0	0	0	0	0	0	0	0	0	0	0	0	0	0		
2:00 PM	0	0	0	0	1	0	0	0	0	0	0	0	1	1		
2:15 PM	0	0	0	0	0	0	0	0	0	0	0	0	0	1		
2:30 PM	0	0	0	0	0	0	0	0	0	0	0	0	0	1		
2:45 PM	0	1	0	0	1	0	0	0	0	0	0	0	2	3		
3:00 PM	0	0	0	0	0	1	0	0	0	0	0	0	1	3		
3:15 PM	0	0	0	0	0	0	0	0	0	0	0	0	0	3		
3:30 PM	0	0	0	0	0	0	0	0	0	0	0	0	0	3		
3:45 PM	0	0	0	0	0	0	0	0	0	0	0	0	0	1		
Count Total	1	4	0	0	13	3	0	0	0	1	0	0	22	0		
Peak Hour	0	0	0	0	1	0	0	0	0	0	0	0	1	0		

Note: U-Turn volumes for bikes are included in Left-Turn, if any.



## US-101 NB Ramps Shiloh Rd



Date: 07/30/2022  
 Count Period: 10:00 AM to 4:00 PM  
 Peak Hour: 1:00 PM to 2:00 PM

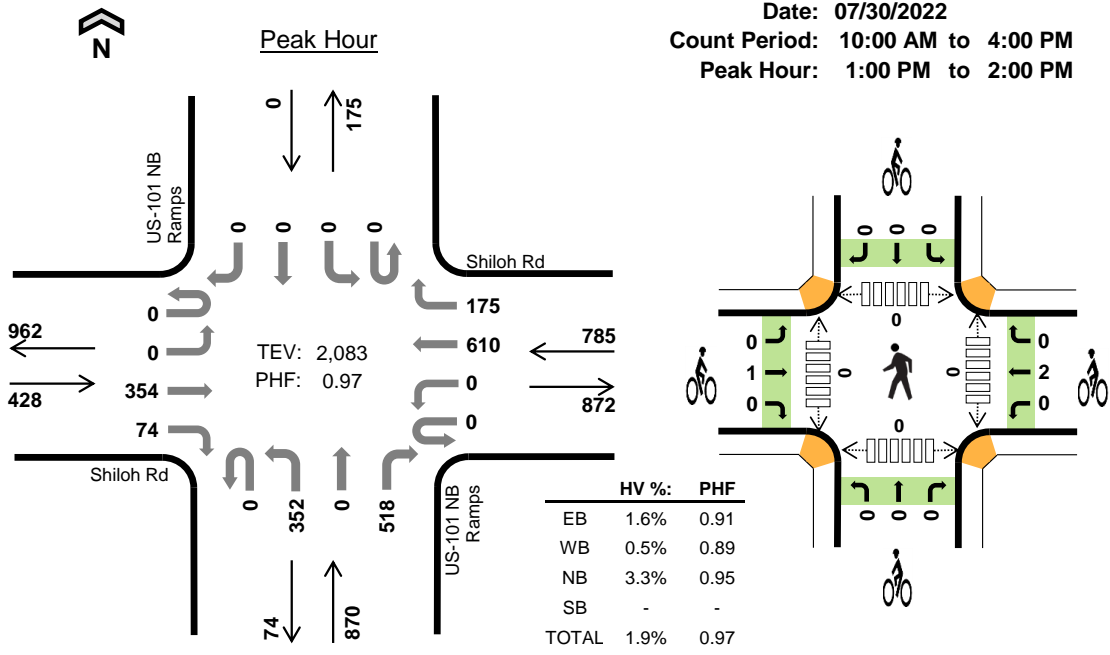

### Six-Hour Count Summaries

Interval Start	Shiloh Rd Eastbound				Shiloh Rd Westbound				US-101 NB Ramps Northbound				US-101 NB Ramps Southbound				15-min Total	Rolling One Hour	
	UT	LT	TH	RT	UT	LT	TH	RT	UT	LT	TH	RT	UT	LT	TH	RT			
1:00 PM	0	0	97	20	0	0	151	41	0	83	0	126	0	0	0	0	518	0	
1:15 PM	0	0	86	17	0	0	139	47	0	91	0	137	0	0	0	0	517	0	
1:30 PM	0	0	87	20	0	0	172	49	0	81	0	130	0	0	0	0	539	0	
1:45 PM	0	0	84	17	0	0	148	38	0	97	0	125	0	0	0	0	509	2,083	
Peak Hour	All	0	0	354	74	0	0	610	175	0	352	0	518	0	0	0	0	2,083	0
	HV	0	0	6	1	0	0	2	2	0	23	0	6	0	0	0	0	40	0
	HV%	-	-	2%	1%	-	-	0%	1%	-	7%	-	1%	-	-	-	-	2%	0

Note: For all three-hour count summary, see next page.

Interval Start	Heavy Vehicle Totals					Bicycles					Pedestrians (Crossing Leg)				
	EB	WB	NB	SB	Total	EB	WB	NB	SB	Total	East	West	North	South	Total
1:00 PM	2	1	10	0	13	1	0	0	0	1	0	0	0	0	0
1:15 PM	0	1	8	0	9	0	0	0	0	0	0	0	0	0	0
1:30 PM	2	1	4	0	7	0	1	0	0	1	0	0	0	0	0
1:45 PM	3	1	7	0	11	0	1	0	0	1	0	0	0	0	0
Peak Hour	7	4	29	0	40	1	2	0	0	3	0	0	0	0	0

Six-Hour Count Summaries																			
Interval Start	Shiloh Rd				Shiloh Rd				US-101 NB Ramps				US-101 NB Ramps				15-min Total	Rolling One Hour	
	Eastbound		Westbound		Northbound		Southbound		UT	LT	TH	RT	UT	LT	TH	RT			
10:00 AM	0	0	70	15	0	0	123	28	0	43	0	107	0	0	0	0	386	0	
10:15 AM	0	0	83	14	0	0	104	27	0	66	0	84	0	0	0	0	378	0	
10:30 AM	0	0	77	22	0	0	127	41	0	68	0	111	0	0	0	0	446	0	
10:45 AM	0	0	60	19	0	0	129	33	0	75	0	110	0	0	0	0	426	1,636	
11:00 AM	0	0	62	18	0	0	136	38	0	67	0	91	0	0	0	0	412	1,662	
11:15 AM	0	0	74	13	0	0	151	40	0	61	0	107	0	0	0	0	446	1,730	
11:30 AM	0	0	100	14	0	0	146	29	0	69	0	108	0	0	0	0	466	1,750	
11:45 AM	0	0	92	27	0	0	134	45	0	71	0	114	0	0	0	0	483	1,807	
12:00 PM	0	0	76	11	0	0	161	35	0	68	0	120	0	0	0	0	471	1,866	
12:15 PM	0	0	70	8	0	0	161	46	0	77	0	96	0	0	0	0	458	1,878	
12:30 PM	0	0	83	8	0	0	161	45	0	85	0	133	0	0	0	0	515	1,927	
12:45 PM	0	0	86	16	0	0	146	39	0	84	0	121	0	0	0	0	492	1,936	
1:00 PM	0	0	97	20	0	0	151	41	0	83	0	126	0	0	0	0	518	1,983	
1:15 PM	0	0	86	17	0	0	139	47	0	91	0	137	0	0	0	0	517	2,042	
1:30 PM	0	0	87	20	0	0	172	49	0	81	0	130	0	0	0	0	539	2,066	
1:45 PM	0	0	84	17	0	0	148	38	0	97	0	125	0	0	0	0	509	2,083	
2:00 PM	0	0	91	12	0	0	144	47	0	76	0	118	0	0	0	0	488	2,053	
2:15 PM	0	0	93	27	0	0	141	50	0	77	0	120	0	0	0	0	508	2,044	
2:30 PM	0	0	88	14	0	0	141	44	0	83	0	113	0	0	0	0	483	1,988	
2:45 PM	0	0	85	15	0	0	141	39	0	82	0	122	0	0	0	0	484	1,963	
3:00 PM	0	0	81	21	0	0	141	40	0	86	0	124	0	0	0	0	493	1,968	
3:15 PM	0	0	72	22	0	0	150	37	0	65	0	118	0	0	0	0	464	1,924	
3:30 PM	0	0	69	10	0	0	145	38	0	96	0	103	0	0	0	0	461	1,902	
3:45 PM	0	0	69	20	0	0	150	43	0	92	0	96	0	0	0	0	470	1,888	
Count Total	0	0	1,935	400	0	0	3,442	959	0	1,843	0	2,734	0	0	0	0	11,313	0	
Peak Hour	All	0	0	354	74	0	0	610	175	0	352	0	518	0	0	0	0	2,083	0
	HV	0	0	6	1	0	0	2	2	0	23	0	6	0	0	0	0	40	0
	HV%	-	-	2%	1%	-	-	0%	1%	-	7%	-	1%	-	-	-	-	2%	0

Note: Six-hour count summary volumes include heavy vehicles but exclude bicycles in overall count.

Interval Start	Heavy Vehicle Totals					Bicycles					Pedestrians (Crossing Leg)				
	EB	WB	NB	SB	Total	EB	WB	NB	SB	Total	East	West	North	South	Total
10:00 AM	1	1	4	0	6	0	1	0	0	1	0	0	1	0	1
10:15 AM	4	3	1	0	8	0	3	0	0	3	0	0	0	0	0
10:30 AM	4	1	2	0	7	0	0	0	0	0	0	0	0	0	0
10:45 AM	0	1	2	0	3	0	1	0	0	1	0	0	0	0	0
11:00 AM	0	1	6	0	7	1	0	0	0	1	0	0	0	1	1
11:15 AM	0	0	3	0	3	0	2	0	0	2	0	0	0	0	0
11:30 AM	2	1	2	0	5	0	2	0	0	2	0	0	0	0	0
11:45 AM	0	0	5	0	5	0	3	0	0	3	0	0	6	1	7
12:00 PM	1	2	4	0	7	0	0	0	0	0	0	0	0	0	0
12:15 PM	1	1	2	0	4	0	0	0	0	0	0	0	0	0	0
12:30 PM	0	3	8	0	11	1	0	0	0	1	0	0	0	0	0
12:45 PM	2	1	5	0	8	0	1	0	0	1	0	0	0	0	0
1:00 PM	2	1	10	0	13	1	0	0	0	1	0	0	0	0	0
1:15 PM	0	1	8	0	9	0	0	0	0	0	0	0	0	0	0
1:30 PM	2	1	4	0	7	0	1	0	0	1	0	0	0	0	0
1:45 PM	3	1	7	0	11	0	1	0	0	1	0	0	0	0	0
2:00 PM	1	0	0	0	1	0	1	0	0	1	0	0	0	0	0
2:15 PM	4	0	2	0	6	0	0	0	0	0	0	0	2	0	2
2:30 PM	0	3	3	0	6	0	2	0	0	2	0	0	0	0	0
2:45 PM	0	3	1	0	4	1	0	0	0	1	0	0	3	0	3
3:00 PM	2	3	7	0	12	0	0	0	0	0	0	0	1	0	1
3:15 PM	0	3	2	0	5	0	0	0	0	0	0	0	0	0	0
3:30 PM	1	1	3	0	5	0	0	0	0	0	0	0	0	0	0
3:45 PM	2	0	4	0	6	0	0	0	0	0	0	0	0	0	0
Count Total	32	32	95	0	159	4	18	0	0	22	0	0	13	2	15
Peak Hour	7	4	29	0	40	1	2	0	0	3	0	0	0	0	0

Six-Hour Count Summaries - Heavy Vehicles																		
Interval Start	Shiloh Rd				Shiloh Rd				US-101 NB Ramps				US-101 NB Ramps				15-min Total	Rolling One Hour
	Eastbound				Westbound				Northbound				Southbound					
	UT	LT	TH	RT	UT	LT	TH	RT	UT	LT	TH	RT	UT	LT	TH	RT		
10:00 AM	0	0	0	1	0	0	1	0	0	4	0	0	0	0	0	0	6	0
10:15 AM	0	0	3	1	0	0	2	1	0	1	0	0	0	0	0	0	8	0
10:30 AM	0	0	3	1	0	0	1	0	0	1	0	1	0	0	0	0	7	0
10:45 AM	0	0	0	0	0	0	1	0	0	1	0	1	0	0	0	0	3	24
11:00 AM	0	0	0	0	0	0	1	0	0	6	0	0	0	0	0	0	7	25
11:15 AM	0	0	0	0	0	0	0	0	0	2	0	1	0	0	0	0	3	20
11:30 AM	0	0	2	0	0	0	1	0	0	0	0	2	0	0	0	0	5	18
11:45 AM	0	0	0	0	0	0	0	0	0	3	0	2	0	0	0	0	5	20
12:00 PM	0	0	1	0	0	0	1	1	0	3	0	1	0	0	0	0	7	20
12:15 PM	0	0	1	0	0	0	0	1	0	2	0	0	0	0	0	0	4	21
12:30 PM	0	0	0	0	0	0	2	1	0	8	0	0	0	0	0	0	11	27
12:45 PM	0	0	2	0	0	0	1	0	0	5	0	0	0	0	0	0	8	30
1:00 PM	0	0	1	1	0	0	1	0	0	8	0	2	0	0	0	0	13	36
1:15 PM	0	0	0	0	0	0	0	1	0	5	0	3	0	0	0	0	9	41
1:30 PM	0	0	2	0	0	0	0	1	0	4	0	0	0	0	0	0	7	37
1:45 PM	0	0	3	0	0	0	1	0	0	6	0	1	0	0	0	0	11	40
2:00 PM	0	0	1	0	0	0	0	0	0	0	0	0	0	0	0	0	1	28
2:15 PM	0	0	4	0	0	0	0	0	0	2	0	0	0	0	0	0	6	25
2:30 PM	0	0	0	0	0	0	3	0	0	3	0	0	0	0	0	0	6	24
2:45 PM	0	0	0	0	0	0	2	1	0	1	0	0	0	0	0	0	4	17
3:00 PM	0	0	2	0	0	0	1	2	0	7	0	0	0	0	0	0	12	28
3:15 PM	0	0	0	0	0	0	3	0	0	2	0	0	0	0	0	0	5	27
3:30 PM	0	0	1	0	0	0	1	0	0	2	0	1	0	0	0	0	5	26
3:45 PM	0	0	1	1	0	0	0	0	0	4	0	0	0	0	0	0	6	28
Count Total	0	0	27	5	0	0	23	9	0	80	0	15	0	0	0	0	159	0
Peak Hour	0	0	6	1	0	0	2	2	0	23	0	6	0	0	0	0	40	0

Six-Hour Count Summaries - Bikes																	
Interval Start	Shiloh Rd			Shiloh Rd			US-101 NB Ramps			US-101 NB Ramps			15-min Total	Rolling One Hour			
	Eastbound			Westbound			Northbound			Southbound							
	LT	TH	RT	LT	TH	RT	LT	TH	RT	LT	TH	RT					
10:00 AM	0	0	0	0	1	0	0	0	0	0	0	0	0	0	0	1	0
10:15 AM	0	0	0	0	3	0	0	0	0	0	0	0	0	0	0	3	0
10:30 AM	0	0	0	0	0	0	0	0	0	0	0	0	0	0	0	0	0
10:45 AM	0	0	0	0	1	0	0	0	0	0	0	0	0	0	0	1	5
11:00 AM	0	1	0	0	0	0	0	0	0	0	0	0	0	0	0	1	5
11:15 AM	0	0	0	0	2	0	0	0	0	0	0	0	0	0	0	2	4
11:30 AM	0	0	0	0	2	0	0	0	0	0	0	0	0	0	0	2	6
11:45 AM	0	0	0	0	3	0	0	0	0	0	0	0	0	0	0	3	8
12:00 PM	0	0	0	0	0	0	0	0	0	0	0	0	0	0	0	0	7
12:15 PM	0	0	0	0	0	0	0	0	0	0	0	0	0	0	0	0	5
12:30 PM	0	1	0	0	0	0	0	0	0	0	0	0	0	0	0	1	4
12:45 PM	0	0	0	0	1	0	0	0	0	0	0	0	0	0	0	1	2
1:00 PM	0	1	0	0	0	0	0	0	0	0	0	0	0	0	0	1	3
1:15 PM	0	0	0	0	0	0	0	0	0	0	0	0	0	0	0	0	3
1:30 PM	0	0	0	0	1	0	0	0	0	0	0	0	0	0	0	1	3
1:45 PM	0	0	0	0	1	0	0	0	0	0	0	0	0	0	0	1	3
2:00 PM	0	0	0	0	1	0	0	0	0	0	0	0	0	0	0	1	3
2:15 PM	0	0	0	0	0	0	0	0	0	0	0	0	0	0	0	0	3
2:30 PM	0	0	0	0	0	2	0	0	0	0	0	0	0	0	0	2	4
2:45 PM	0	1	0	0	0	0	0	0	0	0	0	0	0	0	0	1	4
3:00 PM	0	0	0	0	0	0	0	0	0	0	0	0	0	0	0	0	3
3:15 PM	0	0	0	0	0	0	0	0	0	0	0	0	0	0	0	0	3
3:30 PM	0	0	0	0	0	0	0	0	0	0	0	0	0	0	0	0	1
3:45 PM	0	0	0	0	0	0	0	0	0	0	0	0	0	0	0	0	0
Count Total	0	4	0	0	16	2	0	0	0	0	0	0	0	0	0	22	0
Peak Hour	0	1	0	0	2	0	0	0	0	0	0	0	0	0	0	3	0

Note: U-Turn volumes for bikes are included in Left-Turn, if any.

### US-101 SB Ramps Shiloh Rd



Date: 07/30/2022  
 Count Period: 10:00 AM to 4:00 PM  
 Peak Hour: 1:00 PM to 2:00 PM

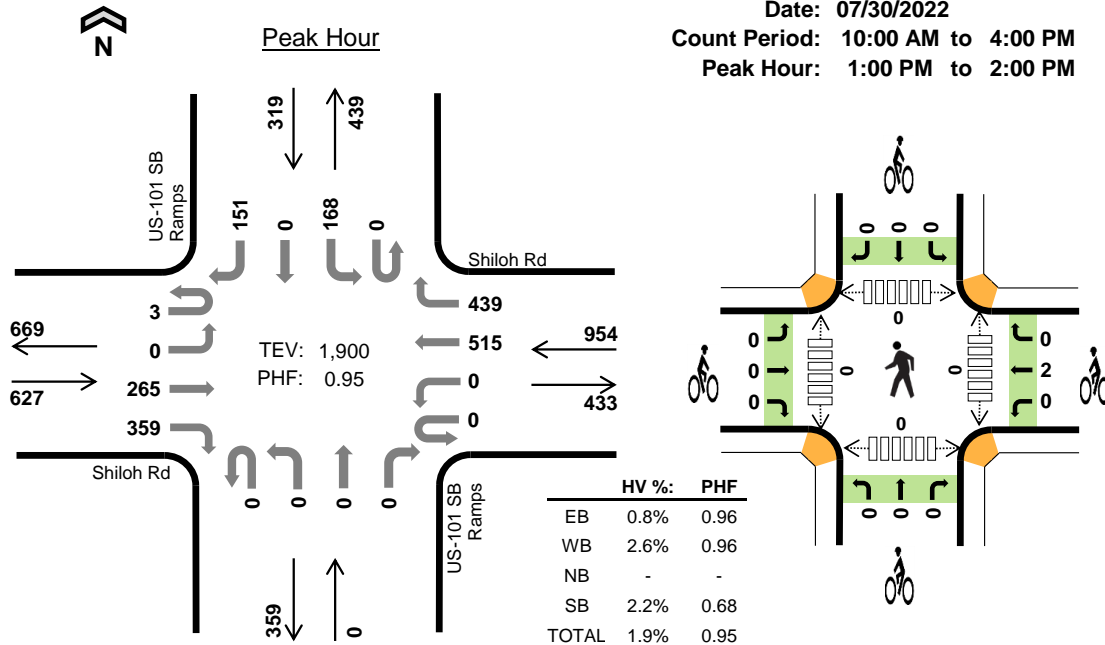

#### Six-Hour Count Summaries

Interval Start	Shiloh Rd				Shiloh Rd				US-101 SB Ramps				US-101 SB Ramps				15-min Total	Rolling One Hour	
	Eastbound		Westbound		Northbound		Southbound		UT	LT	TH	RT	UT	LT	TH	RT			
1:00 PM	0	0	69	88	0	0	118	108	0	0	0	0	0	46	0	71	500	0	
1:15 PM	0	0	63	101	0	0	131	102	0	0	0	0	0	42	0	34	473	0	
1:30 PM	2	0	74	83	0	0	131	118	0	0	0	0	0	37	0	24	469	0	
1:45 PM	1	0	59	87	0	0	135	111	0	0	0	0	0	43	0	22	458	1,900	
Peak Hour	All	3	0	265	359	0	0	515	439	0	0	0	0	0	168	0	151	1,900	0
	HV	0	0	3	2	0	0	15	10	0	0	0	0	0	3	0	4	37	0
	HV%	0%	-	1%	1%	-	-	3%	2%	-	-	-	-	-	2%	-	3%	2%	0

Note: For all three-hour count summary, see next page.

Interval Start	Heavy Vehicle Totals					Bicycles					Pedestrians (Crossing Leg)				
	EB	WB	NB	SB	Total	EB	WB	NB	SB	Total	East	West	North	South	Total
1:00 PM	2	9	0	0	11	0	0	0	0	0	0	0	0	0	0
1:15 PM	1	4	0	1	6	0	0	0	0	0	0	0	0	0	0
1:30 PM	2	4	0	2	8	0	1	0	0	1	0	0	0	0	0
1:45 PM	0	8	0	4	12	0	1	0	0	1	0	0	0	0	0
Peak Hour	5	25	0	7	37	0	2	0	0	2	0	0	0	0	0

<b>Six-Hour Count Summaries</b>																			
Interval Start	Shiloh Rd				Shiloh Rd				US-101 SB Ramps				US-101 SB Ramps				15-min Total	Rolling One Hour	
	Eastbound		Westbound		Northbound		Southbound		Eastbound		Westbound		Northbound		Southbound				
	UT	LT	TH	RT	UT	LT	TH	RT	UT	LT	TH	RT	UT	LT	TH	RT			
10:00 AM	0	0	55	75	0	0	78	81	0	0	0	0	0	25	0	16	330	0	
10:15 AM	0	0	64	82	0	0	99	74	0	0	0	0	0	38	0	12	369	0	
10:30 AM	0	0	62	74	0	0	110	88	0	0	0	0	0	39	0	17	390	0	
10:45 AM	1	0	50	60	0	0	114	83	0	0	0	0	0	31	0	19	358	1,447	
11:00 AM	2	0	56	76	0	0	108	97	0	0	0	0	0	29	0	25	393	1,510	
11:15 AM	0	0	60	92	0	0	102	108	0	0	0	0	0	28	0	25	415	1,556	
11:30 AM	0	0	71	75	0	0	110	103	0	0	0	0	0	43	0	30	432	1,598	
11:45 AM	0	0	87	75	0	0	114	94	0	0	0	0	0	34	0	20	424	1,664	
12:00 PM	0	0	50	93	0	0	123	102	0	0	0	0	0	38	0	19	425	1,696	
12:15 PM	0	0	44	77	0	0	131	106	0	0	0	0	0	33	0	24	415	1,696	
12:30 PM	1	0	46	69	0	0	122	121	0	0	0	0	0	46	0	23	428	1,692	
12:45 PM	0	0	60	92	0	0	136	106	0	0	0	0	0	42	0	21	457	1,725	
<b>1:00 PM</b>	<b>0</b>	<b>0</b>	<b>69</b>	<b>88</b>	<b>0</b>	<b>0</b>	<b>118</b>	<b>108</b>	<b>0</b>	<b>0</b>	<b>0</b>	<b>0</b>	<b>0</b>	<b>46</b>	<b>0</b>	<b>71</b>	<b>500</b>	<b>1,800</b>	
<b>1:15 PM</b>	<b>0</b>	<b>0</b>	<b>63</b>	<b>101</b>	<b>0</b>	<b>0</b>	<b>131</b>	<b>102</b>	<b>0</b>	<b>0</b>	<b>0</b>	<b>0</b>	<b>0</b>	<b>42</b>	<b>0</b>	<b>34</b>	<b>473</b>	<b>1,858</b>	
<b>1:30 PM</b>	<b>2</b>	<b>0</b>	<b>74</b>	<b>83</b>	<b>0</b>	<b>0</b>	<b>131</b>	<b>118</b>	<b>0</b>	<b>0</b>	<b>0</b>	<b>0</b>	<b>0</b>	<b>37</b>	<b>0</b>	<b>24</b>	<b>469</b>	<b>1,899</b>	
<b>1:45 PM</b>	<b>1</b>	<b>0</b>	<b>59</b>	<b>87</b>	<b>0</b>	<b>0</b>	<b>135</b>	<b>111</b>	<b>0</b>	<b>0</b>	<b>0</b>	<b>0</b>	<b>0</b>	<b>43</b>	<b>0</b>	<b>22</b>	<b>458</b>	<b>1,900</b>	
2:00 PM	0	0	58	99	0	0	127	102	0	0	0	0	0	45	0	16	447	1,847	
2:15 PM	1	0	72	96	0	0	114	107	0	0	0	0	0	47	0	16	453	1,827	
2:30 PM	0	0	46	79	0	0	128	101	0	0	0	0	0	53	0	23	430	1,788	
2:45 PM	0	0	72	101	0	0	119	104	0	0	0	0	0	35	0	17	448	1,778	
3:00 PM	0	0	56	81	0	0	125	103	0	0	0	0	0	39	0	15	419	1,750	
3:15 PM	0	0	61	82	0	0	103	114	0	0	0	0	0	37	0	19	416	1,713	
3:30 PM	1	0	52	74	0	0	132	105	0	0	0	0	0	25	0	18	407	1,690	
3:45 PM	0	0	63	101	0	0	145	97	0	0	0	0	0	29	0	16	451	1,693	
Count Total	9	0	1,450	2,012	0	0	2,855	2,435	0	0	0	0	0	904	0	542	10,207	0	
Peak Hour	All	3	0	265	359	0	0	515	439	0	0	0	0	0	168	0	151	1,900	0
	HV	0	0	3	2	0	0	15	10	0	0	0	0	0	3	0	4	37	0
	HV%	0%	-	1%	1%	-	-	3%	2%	-	-	-	-	-	2%	-	3%	2%	0

Note: Six-hour count summary volumes include heavy vehicles but exclude bicycles in overall count.

Interval Start	Heavy Vehicle Totals					Bicycles					Pedestrians (Crossing Leg)				
	EB	WB	NB	SB	Total	EB	WB	NB	SB	Total	East	West	North	South	Total
10:00 AM	3	3	0	0	6	0	2	0	0	2	0	0	1	0	1
10:15 AM	7	7	0	0	14	0	1	0	0	1	0	0	0	0	0
10:30 AM	7	5	0	1	13	0	0	0	0	0	0	0	0	0	0
10:45 AM	2	3	0	0	5	1	1	0	0	2	0	0	0	0	0
11:00 AM	0	8	0	2	10	1	0	0	0	1	0	0	0	0	0
11:15 AM	5	2	0	0	7	0	2	0	0	2	0	0	7	0	7
11:30 AM	3	1	0	2	6	1	0	0	0	1	0	0	0	0	0
11:45 AM	1	3	0	1	5	0	3	0	0	3	0	0	0	0	0
12:00 PM	1	5	0	0	6	0	0	0	0	0	0	0	0	0	0
12:15 PM	2	1	0	1	4	0	0	0	0	0	0	0	0	0	0
12:30 PM	3	10	0	2	15	1	1	0	0	2	0	0	0	0	0
12:45 PM	3	6	0	1	10	1	1	0	0	2	0	0	0	0	0
<b>1:00 PM</b>	<b>2</b>	<b>9</b>	<b>0</b>	<b>0</b>	<b>11</b>	<b>0</b>	<b>0</b>	<b>0</b>	<b>0</b>	<b>0</b>	<b>0</b>	<b>0</b>	<b>0</b>	<b>0</b>	<b>0</b>
<b>1:15 PM</b>	<b>1</b>	<b>4</b>	<b>0</b>	<b>1</b>	<b>6</b>	<b>0</b>	<b>0</b>	<b>0</b>	<b>0</b>	<b>0</b>	<b>0</b>	<b>0</b>	<b>0</b>	<b>0</b>	<b>0</b>
<b>1:30 PM</b>	<b>2</b>	<b>4</b>	<b>0</b>	<b>2</b>	<b>8</b>	<b>0</b>	<b>1</b>	<b>0</b>	<b>0</b>	<b>1</b>	<b>0</b>	<b>0</b>	<b>0</b>	<b>0</b>	<b>0</b>
<b>1:45 PM</b>	<b>0</b>	<b>8</b>	<b>0</b>	<b>4</b>	<b>12</b>	<b>0</b>	<b>1</b>	<b>0</b>	<b>0</b>	<b>1</b>	<b>0</b>	<b>0</b>	<b>0</b>	<b>0</b>	<b>0</b>
2:00 PM	0	4	0	1	5	0	1	0	0	1	0	0	0	0	0
2:15 PM	5	3	0	1	9	0	0	0	0	0	0	0	0	0	0
2:30 PM	2	6	0	0	8	0	2	0	0	2	0	0	0	0	0
2:45 PM	1	2	0	0	3	1	0	0	0	1	0	0	3	0	3
3:00 PM	2	8	0	2	12	0	1	0	0	1	0	0	1	0	1
3:15 PM	0	4	0	0	4	0	0	0	0	0	0	0	0	0	0
3:30 PM	2	4	0	0	6	0	0	0	0	0	0	0	1	0	1
3:45 PM	2	4	0	1	7	0	0	0	0	0	0	0	0	0	0
Count Total	56	114	0	22	192	6	17	0	0	23	0	0	13	0	13
Peak Hour	5	25	0	7	37	0	2	0	0	2	0	0	0	0	0

Six-Hour Count Summaries - Heavy Vehicles																		
Interval Start	Shiloh Rd				Shiloh Rd				US-101 SB Ramps				US-101 SB Ramps				15-min Total	Rolling One Hour
	Eastbound				Westbound				Northbound				Southbound					
	UT	LT	TH	RT	UT	LT	TH	RT	UT	LT	TH	RT	UT	LT	TH	RT		
10:00 AM	0	0	1	2	0	0	3	0	0	0	0	0	0	0	0	6	0	
10:15 AM	0	0	3	4	0	0	3	4	0	0	0	0	0	0	0	14	0	
10:30 AM	0	0	4	3	0	0	4	1	0	0	0	0	0	0	1	13	0	
10:45 AM	0	0	0	2	0	0	1	2	0	0	0	0	0	0	0	5	38	
11:00 AM	0	0	0	0	0	0	7	1	0	0	0	0	0	0	2	10	42	
11:15 AM	0	0	0	5	0	0	2	0	0	0	0	0	0	0	0	7	35	
11:30 AM	0	0	1	2	0	0	1	0	0	0	0	0	0	1	0	6	28	
11:45 AM	0	0	0	1	0	0	3	0	0	0	0	0	0	1	0	5	28	
12:00 PM	0	0	1	0	0	0	3	2	0	0	0	0	0	0	0	6	24	
12:15 PM	0	0	0	2	0	0	1	0	0	0	0	0	0	1	0	4	21	
12:30 PM	0	0	0	3	0	0	7	3	0	0	0	0	0	0	2	15	30	
12:45 PM	0	0	3	0	0	0	3	3	0	0	0	0	0	0	1	10	35	
<b>1:00 PM</b>	<b>0</b>	<b>0</b>	<b>2</b>	<b>0</b>	<b>0</b>	<b>0</b>	<b>5</b>	<b>4</b>	<b>0</b>	<b>0</b>	<b>0</b>	<b>0</b>	<b>0</b>	<b>0</b>	<b>0</b>	<b>11</b>	<b>40</b>	
1:15 PM	0	0	0	1	0	0	1	3	0	0	0	0	0	0	1	6	42	
1:30 PM	0	0	1	1	0	0	4	0	0	0	0	0	0	2	0	8	35	
1:45 PM	0	0	0	0	0	0	5	3	0	0	0	0	0	1	0	12	37	
2:00 PM	0	0	0	0	0	0	2	2	0	0	0	0	0	1	0	5	31	
2:15 PM	0	0	3	2	0	0	3	0	0	0	0	0	0	1	0	9	34	
2:30 PM	0	0	0	2	0	0	3	3	0	0	0	0	0	0	0	8	34	
2:45 PM	0	0	0	1	0	0	0	2	0	0	0	0	0	0	0	3	25	
3:00 PM	0	0	2	0	0	0	7	1	0	0	0	0	0	0	2	12	32	
3:15 PM	0	0	0	0	0	0	2	2	0	0	0	0	0	0	0	4	27	
3:30 PM	0	0	1	1	0	0	4	0	0	0	0	0	0	0	0	6	25	
3:45 PM	0	0	2	0	0	0	3	1	0	0	0	0	0	0	1	7	29	
Count Total	0	0	24	32	0	0	77	37	0	0	0	0	0	8	0	14	192	0
Peak Hour	0	0	3	2	0	0	15	10	0	0	0	0	0	3	0	4	37	0

Six-Hour Count Summaries - Bikes

Interval Start	Shiloh Rd			Shiloh Rd			US-101 SB Ramps			US-101 SB Ramps			15-min Total	Rolling One Hour
	Eastbound			Westbound			Northbound			Southbound				
	LT	TH	RT	LT	TH	RT	LT	TH	RT	LT	TH	RT		
10:00 AM	0	0	0	0	2	0	0	0	0	0	0	0	2	0
10:15 AM	0	0	0	0	1	0	0	0	0	0	0	0	1	0
10:30 AM	0	0	0	0	0	0	0	0	0	0	0	0	0	0
10:45 AM	0	1	0	0	1	0	0	0	0	0	0	0	2	5
11:00 AM	0	1	0	0	0	0	0	0	0	0	0	0	1	4
11:15 AM	0	0	0	0	2	0	0	0	0	0	0	0	2	5
11:30 AM	0	1	0	0	0	0	0	0	0	0	0	0	1	6
11:45 AM	0	0	0	0	3	0	0	0	0	0	0	0	3	7
12:00 PM	0	0	0	0	0	0	0	0	0	0	0	0	0	6
12:15 PM	0	0	0	0	0	0	0	0	0	0	0	0	0	4
12:30 PM	0	1	0	0	1	0	0	0	0	0	0	0	2	5
12:45 PM	0	1	0	0	1	0	0	0	0	0	0	0	2	4
<b>1:00 PM</b>	<b>0</b>	<b>0</b>	<b>0</b>	<b>0</b>	<b>0</b>	<b>0</b>	<b>0</b>	<b>0</b>	<b>0</b>	<b>0</b>	<b>0</b>	<b>0</b>	<b>0</b>	<b>4</b>
1:15 PM	0	0	0	0	0	0	0	0	0	0	0	0	0	4
1:30 PM	0	0	0	0	1	0	0	0	0	0	0	0	1	3
1:45 PM	0	0	0	0	1	0	0	0	0	0	0	0	1	2
2:00 PM	0	0	0	0	1	0	0	0	0	0	0	0	1	3
2:15 PM	0	0	0	0	0	0	0	0	0	0	0	0	0	3
2:30 PM	0	0	0	0	2	0	0	0	0	0	0	0	2	4
2:45 PM	0	1	0	0	0	0	0	0	0	0	0	0	1	4
3:00 PM	0	0	0	0	1	0	0	0	0	0	0	0	1	4
3:15 PM	0	0	0	0	0	0	0	0	0	0	0	0	0	4
3:30 PM	0	0	0	0	0	0	0	0	0	0	0	0	0	2
3:45 PM	0	0	0	0	0	0	0	0	0	0	0	0	0	1
Count Total	0	6	0	0	17	0	0	0	0	0	0	0	23	0
Peak Hour	0	0	0	0	2	0	0	0	0	0	0	0	2	0

Note: U-Turn volumes for bikes are included in Left-Turn, if any.

# Caletti Ave Shiloh Rd



Peak Hour

Date: 07/30/2022  
 Count Period: 10:00 AM to 4:00 PM  
 Peak Hour: 12:45 PM to 1:45 PM

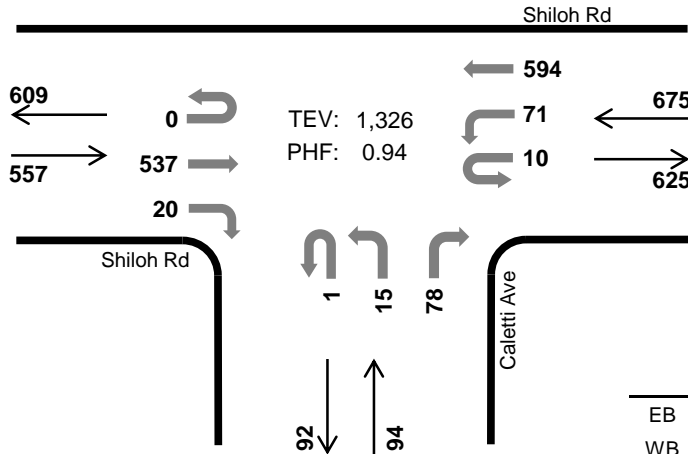

TEV: 1,326  
 PHF: 0.94

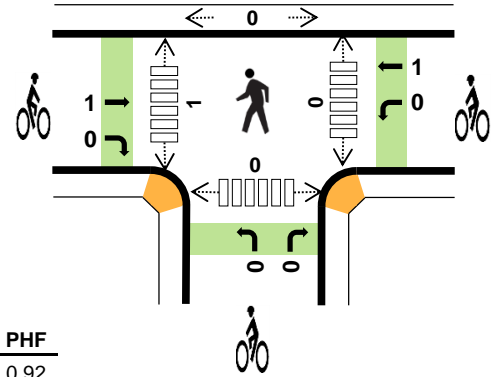

	HV %:	PHF
EB	0.9%	0.92
WB	2.2%	0.87
NB	3.2%	0.78
SB	-	-
TOTAL	1.7%	0.94

## Six-Hour Count Summaries

Interval Start	Shiloh Rd Eastbound				Shiloh Rd Westbound				Caletti Ave Northbound				n/a Southbound				15-min Total	Rolling One Hour	
	UT	LT	TH	RT	UT	LT	TH	RT	UT	LT	TH	RT	UT	LT	TH	RT			
12:45 PM	0	0	118	5	3	21	136	0	0	5	0	25	0	0	0	0	313	0	
1:00 PM	0	0	130	4	4	15	176	0	1	1	0	21	0	0	0	0	352	0	
1:15 PM	0	0	147	4	1	17	149	0	0	5	0	16	0	0	0	0	339	0	
1:30 PM	0	0	142	7	2	18	133	0	0	4	0	16	0	0	0	0	322	1,326	
Peak Hour	All	0	0	537	20	10	71	594	0	1	15	0	78	0	0	0	0	1,326	0
	HV	0	0	5	0	0	11	4	0	0	0	0	3	0	0	0	0	23	0
	HV%	-	-	1%	0%	0%	15%	1%	-	0%	0%	-	4%	-	-	-	-	2%	0

Note: For all three-hour count summary, see next page.

Interval Start	Heavy Vehicle Totals					Bicycles					Pedestrians (Crossing Leg)				
	EB	WB	NB	SB	Total	EB	WB	NB	SB	Total	East	West	North	South	Total
12:45 PM	2	4	1	0	7	1	0	0	0	1	0	0	0	0	0
1:00 PM	1	4	1	0	6	0	0	0	0	0	0	0	0	0	0
1:15 PM	1	3	1	0	5	0	0	0	0	0	0	0	0	0	0
1:30 PM	1	4	0	0	5	0	1	0	0	1	0	1	0	0	1
Peak Hour	5	15	3	0	23	1	1	0	0	2	0	1	0	0	1

### Six-Hour Count Summaries

Interval Start	Shiloh Rd				Shiloh Rd				Caletti Ave				n/a				15-min Total	Rolling One Hour	
	Eastbound				Westbound				Northbound				Southbound						
	UT	LT	TH	RT	UT	LT	TH	RT	UT	LT	TH	RT	UT	LT	TH	RT			
10:00 AM	0	0	110	4	2	13	79	0	0	4	0	19	0	0	0	0	231	0	
10:15 AM	0	0	121	5	3	11	95	0	0	1	0	21	0	0	0	0	257	0	
10:30 AM	0	0	123	5	5	17	112	0	0	2	0	8	0	0	0	0	272	0	
10:45 AM	0	0	87	6	4	15	115	0	0	4	0	19	0	0	0	0	250	1,010	
11:00 AM	0	0	113	5	7	23	105	0	0	5	0	18	0	0	0	0	276	1,055	
11:15 AM	0	0	132	4	3	19	107	0	0	3	0	19	0	0	0	0	287	1,085	
11:30 AM	0	0	114	6	5	17	120	0	0	1	0	22	0	0	0	0	285	1,098	
11:45 AM	0	0	141	3	3	9	125	0	0	2	0	20	0	0	0	0	303	1,151	
12:00 PM	0	0	115	3	2	15	116	0	0	2	0	25	0	0	0	0	278	1,153	
12:15 PM	0	0	106	7	2	16	141	0	0	4	0	15	0	0	0	0	291	1,157	
12:30 PM	0	0	106	5	3	20	117	0	0	4	0	14	0	0	0	0	269	1,141	
<b>12:45 PM</b>	<b>0</b>	<b>0</b>	<b>118</b>	<b>5</b>	<b>3</b>	<b>21</b>	<b>136</b>	<b>0</b>	<b>0</b>	<b>5</b>	<b>0</b>	<b>25</b>	<b>0</b>	<b>0</b>	<b>0</b>	<b>0</b>	<b>313</b>	<b>1,151</b>	
<b>1:00 PM</b>	<b>0</b>	<b>0</b>	<b>130</b>	<b>4</b>	<b>4</b>	<b>15</b>	<b>176</b>	<b>0</b>	<b>1</b>	<b>1</b>	<b>0</b>	<b>21</b>	<b>0</b>	<b>0</b>	<b>0</b>	<b>0</b>	<b>352</b>	<b>1,225</b>	
<b>1:15 PM</b>	<b>0</b>	<b>0</b>	<b>147</b>	<b>4</b>	<b>1</b>	<b>17</b>	<b>149</b>	<b>0</b>	<b>0</b>	<b>5</b>	<b>0</b>	<b>16</b>	<b>0</b>	<b>0</b>	<b>0</b>	<b>0</b>	<b>339</b>	<b>1,273</b>	
<b>1:30 PM</b>	<b>0</b>	<b>0</b>	<b>142</b>	<b>7</b>	<b>2</b>	<b>18</b>	<b>133</b>	<b>0</b>	<b>0</b>	<b>4</b>	<b>0</b>	<b>16</b>	<b>0</b>	<b>0</b>	<b>0</b>	<b>0</b>	<b>322</b>	<b>1,326</b>	
1:45 PM	0	0	114	6	5	23	134	0	0	1	0	25	0	0	0	0	308	1,321	
2:00 PM	0	0	133	0	2	14	128	0	0	2	0	20	0	0	0	0	299	1,268	
2:15 PM	0	0	143	2	5	16	105	0	0	2	0	30	0	0	0	0	303	1,232	
2:30 PM	0	0	104	1	1	19	126	0	0	2	0	19	0	0	0	0	272	1,182	
2:45 PM	0	0	145	1	6	7	126	0	0	4	0	19	0	0	0	0	308	1,182	
3:00 PM	0	0	122	1	1	14	117	0	0	1	0	15	0	0	0	0	271	1,154	
3:15 PM	0	0	119	2	2	9	109	0	0	0	0	18	0	0	0	0	259	1,110	
3:30 PM	0	0	117	2	0	11	137	0	0	0	0	10	0	0	0	0	277	1,115	
3:45 PM	0	0	150	2	3	12	145	0	0	3	0	13	0	0	0	0	328	1,135	
Count Total	0	0	2,952	90	74	371	2,953	0	1	62	0	447	0	0	0	0	6,950	0	
Peak Hour	All	0	0	537	20	10	71	594	0	1	15	0	78	0	0	0	0	1,326	0
	HV	0	0	5	0	0	11	4	0	0	0	0	3	0	0	0	0	23	0
	HV%	-	-	1%	0%	0%	15%	1%	-	0%	0%	-	4%	-	-	-	-	2%	0

Note: Six-hour count summary volumes include heavy vehicles but exclude bicycles in overall count.

Interval Start	Heavy Vehicle Totals					Bicycles					Pedestrians (Crossing Leg)				
	EB	WB	NB	SB	Total	EB	WB	NB	SB	Total	East	West	North	South	Total
10:00 AM	2	3	1	0	6	0	2	0	0	2	0	0	2	0	2
10:15 AM	4	3	5	0	12	0	4	0	0	4	0	0	0	0	0
10:30 AM	6	4	2	0	12	0	0	0	0	0	0	0	0	0	0
10:45 AM	0	1	4	0	5	1	1	0	0	2	0	0	0	0	0
11:00 AM	0	8	0	0	8	0	0	0	0	0	0	0	0	0	0
11:15 AM	0	5	4	0	9	0	0	0	0	0	0	0	0	0	0
11:30 AM	0	2	3	0	5	1	0	0	0	1	0	0	0	0	0
11:45 AM	0	5	1	0	6	0	3	0	0	3	0	0	0	0	0
12:00 PM	1	3	2	0	6	0	0	0	0	0	0	0	0	2	2
12:15 PM	1	2	2	0	5	0	0	0	0	0	0	0	0	0	0
12:30 PM	2	9	2	0	13	1	0	0	0	1	0	0	0	0	0
<b>12:45 PM</b>	<b>2</b>	<b>4</b>	<b>1</b>	<b>0</b>	<b>7</b>	<b>1</b>	<b>0</b>	<b>0</b>	<b>0</b>	<b>1</b>	<b>0</b>	<b>0</b>	<b>0</b>	<b>0</b>	<b>0</b>
<b>1:00 PM</b>	<b>1</b>	<b>4</b>	<b>1</b>	<b>0</b>	<b>6</b>	<b>0</b>	<b>0</b>	<b>0</b>	<b>0</b>	<b>0</b>	<b>0</b>	<b>0</b>	<b>0</b>	<b>0</b>	<b>0</b>
<b>1:15 PM</b>	<b>1</b>	<b>3</b>	<b>1</b>	<b>0</b>	<b>5</b>	<b>0</b>	<b>0</b>	<b>0</b>	<b>0</b>	<b>0</b>	<b>0</b>	<b>0</b>	<b>0</b>	<b>0</b>	<b>0</b>
<b>1:30 PM</b>	<b>1</b>	<b>4</b>	<b>0</b>	<b>0</b>	<b>5</b>	<b>0</b>	<b>1</b>	<b>0</b>	<b>0</b>	<b>1</b>	<b>0</b>	<b>1</b>	<b>0</b>	<b>0</b>	<b>1</b>
1:45 PM	1	9	0	0	10	0	0	0	0	0	0	0	0	0	0
2:00 PM	0	2	0	0	2	0	1	0	0	1	0	0	0	1	1
2:15 PM	4	3	10	0	17	0	0	0	0	0	0	0	0	0	0
2:30 PM	1	3	1	0	5	0	2	0	0	2	0	0	0	0	0
2:45 PM	0	1	2	0	3	0	0	1	0	1	0	0	0	0	0
3:00 PM	2	10	0	0	12	0	1	0	0	1	0	0	0	3	3
3:15 PM	0	2	0	0	2	0	0	0	0	0	0	0	0	0	0
3:30 PM	1	4	0	0	5	0	0	0	0	0	0	0	0	0	0



3:45 PM	2	5	0	0	7	0	0	0	0	0	0	0	0	0	
Count Total	32	99	42	0	173	4	15	1	0	20	0	1	2	6	9
Peak Hr	5	15	3	0	23	1	1	0	0	2	0	1	0	0	1

**Six-Hour Count Summaries - Heavy Vehicles**

Interval Start	Shiloh Rd				Shiloh Rd				Caletti Ave				n/a				15-min Total	Rolling One Hour
	Eastbound				Westbound				Northbound				Southbound					
	UT	LT	TH	RT	UT	LT	TH	RT	UT	LT	TH	RT	UT	LT	TH	RT		
10:00 AM	0	0	2	0	0	2	1	0	0	0	0	1	0	0	0	0	6	0
10:15 AM	0	0	4	0	0	2	1	0	0	0	0	5	0	0	0	0	12	0
10:30 AM	0	0	5	1	0	1	3	0	0	0	0	2	0	0	0	0	12	0
10:45 AM	0	0	0	0	0	1	0	0	0	2	0	2	0	0	0	0	5	35
11:00 AM	0	0	0	0	0	6	2	0	0	0	0	0	0	0	0	0	8	37
11:15 AM	0	0	0	0	1	4	0	0	0	0	0	4	0	0	0	0	9	34
11:30 AM	0	0	0	0	0	2	0	0	0	0	0	3	0	0	0	0	5	27
11:45 AM	0	0	0	0	0	4	1	0	0	0	0	1	0	0	0	0	6	28
12:00 PM	0	0	1	0	0	3	0	0	0	0	0	2	0	0	0	0	6	26
12:15 PM	0	0	0	1	0	1	1	0	0	0	0	2	0	0	0	0	5	22
12:30 PM	0	0	2	0	0	7	2	0	0	1	0	1	0	0	0	0	13	30
<b>12:45 PM</b>	<b>0</b>	<b>0</b>	<b>2</b>	<b>0</b>	<b>0</b>	<b>4</b>	<b>0</b>	<b>0</b>	<b>0</b>	<b>0</b>	<b>0</b>	<b>1</b>	<b>0</b>	<b>0</b>	<b>0</b>	<b>0</b>	<b>7</b>	<b>31</b>
<b>1:00 PM</b>	<b>0</b>	<b>0</b>	<b>1</b>	<b>0</b>	<b>0</b>	<b>4</b>	<b>0</b>	<b>0</b>	<b>0</b>	<b>0</b>	<b>0</b>	<b>1</b>	<b>0</b>	<b>0</b>	<b>0</b>	<b>0</b>	<b>6</b>	<b>31</b>
<b>1:15 PM</b>	<b>0</b>	<b>0</b>	<b>1</b>	<b>0</b>	<b>0</b>	<b>0</b>	<b>3</b>	<b>0</b>	<b>0</b>	<b>0</b>	<b>0</b>	<b>1</b>	<b>0</b>	<b>0</b>	<b>0</b>	<b>0</b>	<b>5</b>	<b>31</b>
<b>1:30 PM</b>	<b>0</b>	<b>0</b>	<b>1</b>	<b>0</b>	<b>0</b>	<b>3</b>	<b>1</b>	<b>0</b>	<b>0</b>	<b>0</b>	<b>0</b>	<b>0</b>	<b>0</b>	<b>0</b>	<b>0</b>	<b>0</b>	<b>5</b>	<b>23</b>
1:45 PM	0	0	0	1	0	6	3	0	0	0	0	0	0	0	0	0	10	26
2:00 PM	0	0	0	0	0	0	2	0	0	0	0	0	0	0	0	0	2	22
2:15 PM	0	0	4	0	0	3	0	0	0	0	0	10	0	0	0	0	17	34
2:30 PM	0	0	1	0	0	3	0	0	0	0	0	1	0	0	0	0	5	34
2:45 PM	0	0	0	0	0	1	0	0	0	0	0	2	0	0	0	0	3	27
3:00 PM	0	0	2	0	0	5	5	0	0	0	0	0	0	0	0	0	12	37
3:15 PM	0	0	0	0	0	1	1	0	0	0	0	0	0	0	0	0	2	22
3:30 PM	0	0	1	0	0	1	3	0	0	0	0	0	0	0	0	0	5	22
3:45 PM	0	0	2	0	0	2	3	0	0	0	0	0	0	0	0	0	7	26
Count Total	0	0	29	3	1	66	32	0	0	3	0	39	0	0	0	0	173	0
<b>Peak Hour</b>	<b>0</b>	<b>0</b>	<b>5</b>	<b>0</b>	<b>0</b>	<b>11</b>	<b>4</b>	<b>0</b>	<b>0</b>	<b>0</b>	<b>0</b>	<b>3</b>	<b>0</b>	<b>0</b>	<b>0</b>	<b>0</b>	<b>23</b>	<b>0</b>

**Six-Hour Count Summaries - Bikes**

Interval Start	Shiloh Rd			Shiloh Rd			Caletti Ave			n/a			15-min Total	Rolling One Hour
	Eastbound			Westbound			Northbound			Southbound				
	LT	TH	RT	LT	TH	RT	LT	TH	RT	LT	TH	RT		
10:00 AM	0	0	0	0	2	0	0	0	0	0	0	0	2	0
10:15 AM	0	0	0	0	4	0	0	0	0	0	0	0	4	0
10:30 AM	0	0	0	0	0	0	0	0	0	0	0	0	0	0
10:45 AM	0	1	0	0	1	0	0	0	0	0	0	0	2	8
11:00 AM	0	0	0	0	0	0	0	0	0	0	0	0	0	6
11:15 AM	0	0	0	0	0	0	0	0	0	0	0	0	0	2
11:30 AM	0	1	0	0	0	0	0	0	0	0	0	0	1	3
11:45 AM	0	0	0	0	3	0	0	0	0	0	0	0	3	4
12:00 PM	0	0	0	0	0	0	0	0	0	0	0	0	0	4
12:15 PM	0	0	0	0	0	0	0	0	0	0	0	0	0	4
12:30 PM	0	1	0	0	0	0	0	0	0	0	0	0	1	4
<b>12:45 PM</b>	<b>0</b>	<b>1</b>	<b>0</b>	<b>0</b>	<b>0</b>	<b>0</b>	<b>0</b>	<b>0</b>	<b>0</b>	<b>0</b>	<b>0</b>	<b>0</b>	<b>1</b>	<b>2</b>
<b>1:00 PM</b>	<b>0</b>	<b>0</b>	<b>0</b>	<b>0</b>	<b>0</b>	<b>0</b>	<b>0</b>	<b>0</b>	<b>0</b>	<b>0</b>	<b>0</b>	<b>0</b>	<b>0</b>	<b>2</b>
<b>1:15 PM</b>	<b>0</b>	<b>0</b>	<b>0</b>	<b>0</b>	<b>0</b>	<b>0</b>	<b>0</b>	<b>0</b>	<b>0</b>	<b>0</b>	<b>0</b>	<b>0</b>	<b>0</b>	<b>2</b>
<b>1:30 PM</b>	<b>0</b>	<b>0</b>	<b>0</b>	<b>0</b>	<b>1</b>	<b>0</b>	<b>0</b>	<b>0</b>	<b>0</b>	<b>0</b>	<b>0</b>	<b>0</b>	<b>1</b>	<b>2</b>
1:45 PM	0	0	0	0	0	0	0	0	0	0	0	0	0	1
2:00 PM	0	0	0	0	1	0	0	0	0	0	0	0	1	2
2:15 PM	0	0	0	0	0	0	0	0	0	0	0	0	0	2
2:30 PM	0	0	0	0	2	0	0	0	0	0	0	0	2	3
2:45 PM	0	0	0	0	0	0	0	1	0	0	0	0	1	4
3:00 PM	0	0	0	0	1	0	0	0	0	0	0	0	1	4

3:15 PM	0	0	0	0	0	0	0	0	0	0	0	0	4
3:30 PM	0	0	0	0	0	0	0	0	0	0	0	0	2
3:45 PM	0	0	0	0	0	0	0	0	0	0	0	0	1
Count Total	0	4	0	0	15	0	0	0	1	0	0	0	20
<b>Peak Hour</b>	<b>0</b>	<b>1</b>	<b>0</b>	<b>0</b>	<b>1</b>	<b>0</b>	<b>0</b>	<b>0</b>	<b>0</b>	<b>0</b>	<b>0</b>	<b>0</b>	<b>2</b>

Note: U-Turn volumes for bikes are included in Left-Turn, if any.

### Conde Ln Shiloh Rd



Date: 07/30/2022  
 Count Period: 10:00 AM to 4:00 PM  
 Peak Hour: 12:45 PM to 1:45 PM

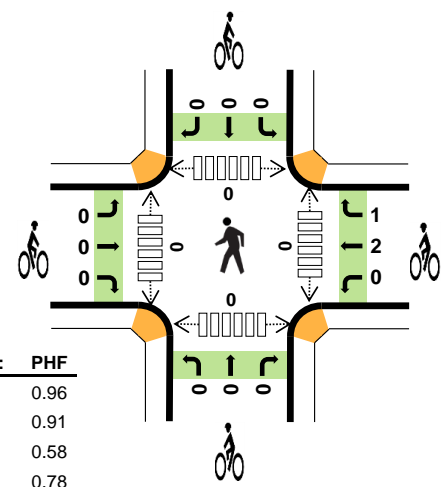
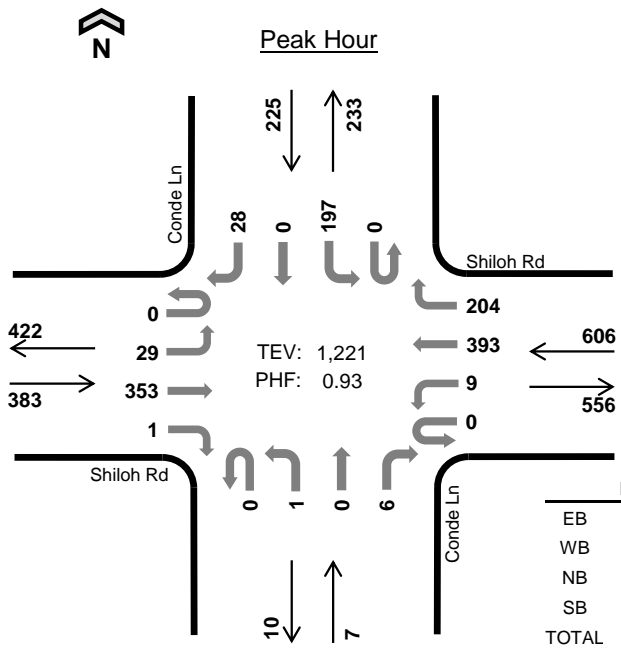

	HV %:	PHF
EB	0.3%	0.96
WB	0.8%	0.91
NB	0.0%	0.58
SB	2.2%	0.78
TOTAL	0.9%	0.93

#### Six-Hour Count Summaries

Interval Start	Shiloh Rd Eastbound				Shiloh Rd Westbound				Conde Ln Northbound				Conde Ln Southbound				15-min Total	Rolling One Hour	
	UT	LT	TH	RT	UT	LT	TH	RT	UT	LT	TH	RT	UT	LT	TH	RT			
12:45 PM	0	7	85	0	0	3	85	55	0	0	0	3	0	34	0	4	276	0	
1:00 PM	0	11	83	0	0	3	124	40	0	0	0	0	0	54	0	6	321	0	
1:15 PM	0	9	87	1	0	0	93	65	0	1	0	1	0	62	0	10	329	0	
1:30 PM	0	2	98	0	0	3	91	44	0	0	0	2	0	47	0	8	295	1,221	
Peak Hour	All	0	29	353	1	0	9	393	204	0	1	0	6	0	197	0	28	1,221	0
	HV	0	0	1	0	0	0	1	4	0	0	0	0	0	4	0	1	11	0
	HV%	-	0%	0%	0%	-	0%	0%	2%	-	0%	-	0%	-	2%	-	4%	1%	0

Note: For all three-hour count summary, see next page.

Interval Start	Heavy Vehicle Totals					Bicycles					Pedestrians (Crossing Leg)				
	EB	WB	NB	SB	Total	EB	WB	NB	SB	Total	East	West	North	South	Total
12:45 PM	0	1	0	2	3	0	1	0	0	1	0	0	0	0	0
1:00 PM	1	0	0	0	1	0	0	0	0	0	0	0	0	0	0
1:15 PM	0	3	0	1	4	0	0	0	0	0	0	0	0	0	0
1:30 PM	0	1	0	2	3	0	2	0	0	2	0	0	0	0	0
Peak Hour	1	5	0	5	11	0	3	0	0	3	0	0	0	0	0

Six-Hour Count Summaries																			
Interval Start	Shiloh Rd				Shiloh Rd				Conde Ln				Conde Ln				15-min Total	Rolling One Hour	
	Eastbound		Westbound		Northbound		Southbound		UT	LT	TH	RT	UT	LT	TH	RT			
10:00 AM	0	5	80	0	0	2	54	24	0	0	0	2	0	26	0	5	198	0	
10:15 AM	1	6	82	1	0	0	64	36	0	0	0	1	0	43	0	4	238	0	
10:30 AM	0	2	82	1	0	1	65	44	0	0	0	2	0	45	0	3	245	0	
10:45 AM	0	3	51	0	0	5	69	49	1	0	3	2	0	39	1	1	224	905	
11:00 AM	0	5	80	0	0	0	72	34	0	1	0	1	0	39	0	7	239	946	
11:15 AM	0	10	89	1	0	0	78	33	0	0	1	0	0	45	0	5	262	970	
11:30 AM	0	6	78	0	0	0	70	47	0	1	0	1	0	44	1	4	252	977	
11:45 AM	0	3	92	0	0	1	80	55	0	0	0	0	0	48	0	4	283	1,036	
12:00 PM	0	3	94	0	0	0	80	37	0	0	0	0	0	29	0	6	249	1,046	
12:15 PM	0	8	68	0	0	1	79	61	0	0	0	2	0	38	0	3	260	1,044	
12:30 PM	0	6	75	0	0	1	72	49	0	0	0	1	0	35	1	6	246	1,038	
12:45 PM	0	7	85	0	0	3	85	55	0	0	0	3	0	34	0	4	276	1,031	
1:00 PM	0	11	83	0	0	3	124	40	0	0	0	0	0	54	0	6	321	1,103	
1:15 PM	0	9	87	1	0	0	93	65	0	1	0	1	0	62	0	10	329	1,172	
1:30 PM	0	2	98	0	0	3	91	44	0	0	0	2	0	47	0	8	295	1,221	
1:45 PM	0	10	72	1	0	3	85	39	0	0	0	4	0	46	0	7	267	1,212	
2:00 PM	0	11	96	0	0	1	80	54	0	0	0	2	0	34	0	5	283	1,174	
2:15 PM	0	5	92	0	0	1	77	35	0	0	0	1	0	57	0	8	276	1,121	
2:30 PM	0	2	69	0	0	1	81	47	0	0	0	0	0	33	0	5	238	1,064	
2:45 PM	0	6	100	0	0	0	71	52	0	0	0	4	0	44	0	5	282	1,079	
3:00 PM	0	16	72	0	0	1	82	45	0	0	0	1	0	55	0	10	282	1,078	
3:15 PM	0	11	71	0	0	0	78	44	0	0	0	2	0	47	1	7	261	1,063	
3:30 PM	0	2	61	0	0	1	86	49	0	1	0	2	1	51	0	3	257	1,082	
3:45 PM	0	9	100	0	1	1	94	51	0	1	0	0	0	55	0	3	315	1,115	
Count Total	1	158	1,957	5	1	29	1,910	1,089	1	5	4	34	1	1,050	4	129	6,378	0	
Peak Hour	All	0	29	353	1	0	9	393	204	0	1	0	6	0	197	0	28	1,221	0
	HV	0	0	1	0	0	0	1	4	0	0	0	0	0	4	0	1	11	0
	HV%	-	0%	0%	0%	-	0%	0%	2%	-	0%	-	0%	-	2%	-	4%	1%	0

Note: Six-hour count summary volumes include heavy vehicles but exclude bicycles in overall count.

Interval Start	Heavy Vehicle Totals					Bicycles					Pedestrians (Crossing Leg)				
	EB	WB	NB	SB	Total	EB	WB	NB	SB	Total	East	West	North	South	Total
10:00 AM	2	1	0	1	4	0	2	0	1	3	0	0	1	0	1
10:15 AM	4	2	0	2	8	0	4	0	0	4	0	0	0	0	0
10:30 AM	3	4	1	3	11	0	0	0	0	0	0	0	0	0	0
10:45 AM	0	2	0	0	2	0	1	0	1	2	0	0	0	0	0
11:00 AM	0	4	0	0	4	1	0	0	0	1	0	0	0	0	0
11:15 AM	0	0	0	1	1	0	2	0	1	3	0	7	7	7	21
11:30 AM	0	1	0	0	1	0	0	0	0	0	0	0	0	0	0
11:45 AM	0	1	0	0	1	0	3	0	2	5	0	0	0	3	3
12:00 PM	1	0	0	1	2	0	0	0	0	0	0	0	0	0	0
12:15 PM	1	1	0	0	2	0	0	0	0	0	0	0	0	0	0
12:30 PM	2	2	0	0	4	0	1	0	0	1	0	0	0	0	0
12:45 PM	0	1	0	2	3	0	1	0	0	1	0	0	0	0	0
1:00 PM	1	0	0	0	1	0	0	0	0	0	0	0	0	0	0
1:15 PM	0	3	0	1	4	0	0	0	0	0	0	0	0	0	0
1:30 PM	0	1	0	2	3	0	2	0	0	2	0	0	0	0	0
1:45 PM	1	2	0	0	3	0	0	0	0	0	0	0	0	0	0
2:00 PM	0	2	0	0	2	0	1	0	0	1	0	1	0	1	2
2:15 PM	2	0	0	3	5	0	0	0	1	1	0	0	0	0	0
2:30 PM	1	2	0	0	3	0	2	0	12	14	0	0	0	0	0
2:45 PM	1	0	0	0	1	0	0	0	0	0	0	1	0	0	1
3:00 PM	1	4	0	2	7	1	0	0	0	1	0	3	0	3	6
3:15 PM	0	2	0	0	2	0	1	0	0	1	0	0	0	0	0
3:30 PM	1	4	0	1	6	0	0	0	0	0	0	0	0	0	0
3:45 PM	1	2	0	1	4	0	0	0	0	0	0	0	0	0	0
Count Total	22	41	1	20	84	2	20	0	18	40	0	12	8	14	34
Peak Hour	1	5	0	5	11	0	3	0	0	3	0	0	0	0	0

<b>Six-Hour Count Summaries - Heavy Vehicles</b>																		
Interval Start	Shiloh Rd				Shiloh Rd				Conde Ln				Conde Ln				15-min Total	Rolling One Hour
	Eastbound				Westbound				Northbound				Southbound					
	UT	LT	TH	RT	UT	LT	TH	RT	UT	LT	TH	RT	UT	LT	TH	RT		
10:00 AM	0	1	1	0	0	0	1	0	0	0	0	0	0	1	0	0	4	0
10:15 AM	0	1	3	0	0	0	2	0	0	0	0	0	0	2	0	0	8	0
10:30 AM	0	0	3	0	0	1	2	1	0	0	0	1	0	2	0	1	11	0
10:45 AM	0	0	0	0	0	0	2	0	0	0	0	0	0	0	0	0	2	25
11:00 AM	0	0	0	0	0	0	3	1	0	0	0	0	0	0	0	0	4	25
11:15 AM	0	0	0	0	0	0	0	0	0	0	0	0	0	1	0	0	1	18
11:30 AM	0	0	0	0	0	0	1	0	0	0	0	0	0	0	0	0	1	8
11:45 AM	0	0	0	0	0	0	1	0	0	0	0	0	0	0	0	0	1	7
12:00 PM	0	0	1	0	0	0	0	0	0	0	0	0	0	1	0	0	2	5
12:15 PM	0	0	1	0	0	0	0	1	0	0	0	0	0	0	0	0	2	6
12:30 PM	0	0	2	0	0	0	1	1	0	0	0	0	0	0	0	0	4	9
12:45 PM	0	0	0	0	0	0	0	1	0	0	0	0	0	2	0	0	3	11
1:00 PM	0	0	1	0	0	0	0	0	0	0	0	0	0	0	0	0	1	10
1:15 PM	0	0	0	0	0	0	1	2	0	0	0	0	0	1	0	0	4	12
1:30 PM	0	0	0	0	0	0	0	1	0	0	0	0	0	1	0	1	3	11
1:45 PM	0	0	1	0	0	0	1	1	0	0	0	0	0	0	0	0	3	11
2:00 PM	0	0	0	0	0	0	0	2	0	0	0	0	0	0	0	0	2	12
2:15 PM	0	0	2	0	0	0	0	0	0	0	0	0	0	3	0	0	5	13
2:30 PM	0	0	1	0	0	0	1	1	0	0	0	0	0	0	0	0	3	13
2:45 PM	0	0	1	0	0	0	0	0	0	0	0	0	0	0	0	0	1	11
3:00 PM	0	0	1	0	0	0	1	3	0	0	0	0	0	2	0	0	7	16
3:15 PM	0	0	0	0	0	0	1	1	0	0	0	0	0	0	0	0	2	13
3:30 PM	0	0	1	0	0	0	3	1	0	0	0	0	0	1	0	0	6	16
3:45 PM	0	0	1	0	0	0	1	1	0	0	0	0	0	1	0	0	4	19
Count Total	0	2	20	0	0	1	22	18	0	0	0	1	0	18	0	2	84	0
Peak Hour	0	0	1	0	0	0	1	4	0	0	0	0	0	4	0	1	11	0

<b>Six-Hour Count Summaries - Bikes</b>																	
Interval Start	Shiloh Rd			Shiloh Rd			Conde Ln			Conde Ln			15-min Total	Rolling One Hour			
	Eastbound			Westbound			Northbound			Southbound							
	LT	TH	RT	LT	TH	RT	LT	TH	RT	LT	TH	RT					
10:00 AM	0	0	0	0	2	0	0	0	0	1	0	0	3	0			
10:15 AM	0	0	0	0	3	1	0	0	0	0	0	0	4	0			
10:30 AM	0	0	0	0	0	0	0	0	0	0	0	0	0	0			
10:45 AM	0	0	0	0	1	0	0	0	0	1	0	0	2	9			
11:00 AM	0	1	0	0	0	0	0	0	0	0	0	0	1	7			
11:15 AM	0	0	0	0	2	0	0	0	0	1	0	0	3	6			
11:30 AM	0	0	0	0	0	0	0	0	0	0	0	0	0	6			
11:45 AM	0	0	0	0	3	0	0	0	0	0	0	2	5	9			
12:00 PM	0	0	0	0	0	0	0	0	0	0	0	0	0	8			
12:15 PM	0	0	0	0	0	0	0	0	0	0	0	0	0	5			
12:30 PM	0	0	0	0	1	0	0	0	0	0	0	0	1	6			
12:45 PM	0	0	0	0	1	0	0	0	0	0	0	0	1	2			
1:00 PM	0	0	0	0	0	0	0	0	0	0	0	0	0	2			
1:15 PM	0	0	0	0	0	0	0	0	0	0	0	0	0	2			
1:30 PM	0	0	0	0	1	1	0	0	0	0	0	0	2	3			
1:45 PM	0	0	0	0	0	0	0	0	0	0	0	0	0	2			
2:00 PM	0	0	0	0	0	1	0	0	0	0	0	0	1	3			
2:15 PM	0	0	0	0	0	0	0	0	0	0	0	1	1	4			
2:30 PM	0	0	0	0	0	2	0	0	0	0	0	12	14	16			
2:45 PM	0	0	0	0	0	0	0	0	0	0	0	0	0	16			
3:00 PM	0	1	0	0	0	0	0	0	0	0	0	0	1	16			
3:15 PM	0	0	0	0	1	0	0	0	0	0	0	0	1	16			
3:30 PM	0	0	0	0	0	0	0	0	0	0	0	0	0	2			
3:45 PM	0	0	0	0	0	0	0	0	0	0	0	0	0	2			
Count Total	0	2	0	0	15	5	0	0	0	3	0	15	40	0			
Peak Hour	0	0	0	0	2	1	0	0	0	0	0	0	3	0			

Note: U-Turn volumes for bikes are included in Left-Turn, if any.

### Gridley Dr Shiloh Rd



Date: 07/30/2022  
 Count Period: 10:00 AM to 4:00 PM  
 Peak Hour: 1:15 PM to 2:15 PM

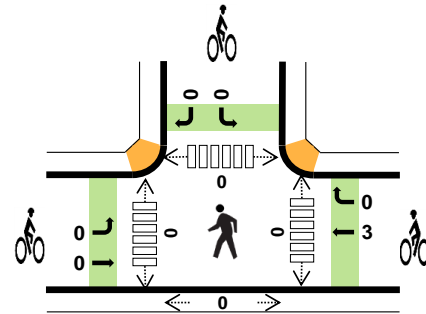
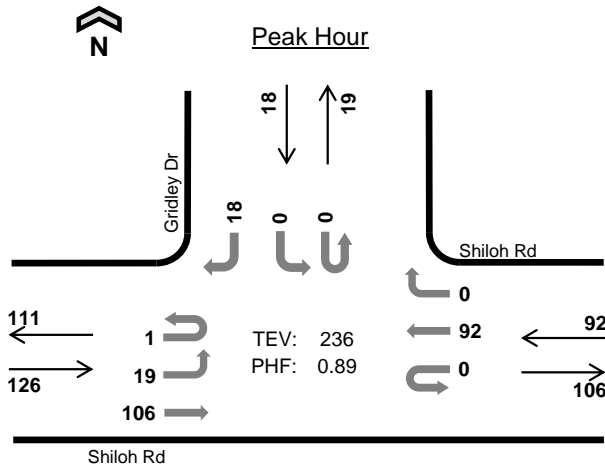

TEV: 236  
 PHF: 0.89

	HV %:	PHF
EB	1.6%	0.93
WB	0.0%	0.88
NB	-	-
SB	0.0%	0.56
TOTAL	0.8%	0.89

#### Six-Hour Count Summaries

Interval Start	Shiloh Rd Eastbound				Shiloh Rd Westbound				N/A Northbound				Gridley Dr Southbound				15-min Total	Rolling One Hour
	UT	LT	TH	RT	UT	LT	TH	RT	UT	LT	TH	RT	UT	LT	TH	RT		
	1:15 PM	0	3	26	0	0	0	24	0	0	0	0	0	0	0	0		
1:30 PM	1	5	23	0	0	0	20	0	0	0	0	0	0	0	0	2	51	0
1:45 PM	0	5	29	0	0	0	22	0	0	0	0	0	0	0	0	8	64	0
2:00 PM	0	6	28	0	0	0	26	0	0	0	0	0	0	0	0	6	66	236
Peak Hour	All	1	19	106	0	0	0	92	0	0	0	0	0	0	0	18	236	0
	HV	0	0	2	0	0	0	0	0	0	0	0	0	0	0	0	2	0
	HV%	0%	0%	2%	-	-	-	0%	-	-	-	-	-	-	-	0%	1%	0

Note: For all three-hour count summary, see next page.

Interval Start	Heavy Vehicle Totals					Bicycles					Pedestrians (Crossing Leg)				
	EB	WB	NB	SB	Total	EB	WB	NB	SB	Total	East	West	North	South	Total
1:15 PM	1	0	0	0	1	0	1	0	0	1	0	0	0	0	0
1:30 PM	0	0	0	0	0	0	0	0	0	0	0	0	0	0	0
1:45 PM	1	0	0	0	1	0	2	0	0	2	0	0	0	0	0
2:00 PM	0	0	0	0	0	0	0	0	0	0	0	0	0	0	0
Peak Hour	2	0	0	0	2	0	3	0	0	3	0	0	0	0	0

Six-Hour Count Summaries																		
Interval Start	Shiloh Rd				Shiloh Rd				N/A				Gridley Dr				15-min Total	Rolling One Hour
	Eastbound				Westbound				Northbound				Southbound					
	UT	LT	TH	RT	UT	LT	TH	RT	UT	LT	TH	RT	UT	LT	TH	RT		
10:00 AM	0	1	19	0	0	0	19	0	0	0	0	0	0	0	1	40	0	
10:15 AM	0	0	21	0	0	0	30	1	0	0	0	0	0	0	3	55	0	
10:30 AM	0	6	22	0	0	0	17	0	0	0	0	0	0	0	4	49	0	
10:45 AM	0	3	26	0	0	0	21	0	0	0	0	0	0	0	4	54	198	
11:00 AM	0	3	30	0	0	0	21	0	0	0	0	0	0	0	5	59	217	
11:15 AM	0	1	16	0	0	0	21	0	0	0	0	0	1	0	4	43	205	
11:30 AM	0	4	22	0	0	0	24	0	0	0	0	0	0	0	3	53	209	
11:45 AM	0	2	27	0	0	0	24	0	0	0	0	0	0	0	2	55	210	
12:00 PM	0	4	30	0	0	0	26	0	0	0	0	0	0	0	3	63	214	
12:15 PM	0	3	18	0	0	0	20	0	0	0	0	0	0	0	0	41	212	
12:30 PM	0	1	24	0	0	0	24	0	0	0	0	0	0	0	2	51	210	
12:45 PM	0	0	15	0	0	0	32	0	0	0	0	0	0	0	2	49	204	
1:00 PM	0	3	29	0	0	0	23	1	0	0	0	0	0	0	2	58	199	
1:15 PM	0	3	26	0	0	0	24	0	0	0	0	0	0	0	2	55	213	
1:30 PM	1	5	23	0	0	0	20	0	0	0	0	0	0	0	2	51	213	
1:45 PM	0	5	29	0	0	0	22	0	0	0	0	0	0	0	8	64	228	
2:00 PM	0	6	28	0	0	0	26	0	0	0	0	0	0	0	6	66	236	
2:15 PM	0	5	15	0	0	0	24	0	0	0	0	0	0	0	0	44	225	
2:30 PM	0	1	27	0	0	0	20	0	0	0	0	0	0	0	4	52	226	
2:45 PM	0	5	15	0	0	0	29	0	0	0	0	0	0	0	2	51	213	
3:00 PM	0	4	16	0	0	0	23	0	0	0	0	0	0	0	2	45	192	
3:15 PM	0	3	18	0	0	0	24	0	0	0	0	0	0	0	0	45	193	
3:30 PM	1	2	14	0	0	0	18	0	0	0	0	0	0	0	2	37	178	
3:45 PM	0	1	17	0	0	0	36	0	0	0	0	0	1	0	3	58	185	
Count Total	2	71	527	0	0	0	568	2	0	0	0	0	0	2	0	1,238	0	
Peak Hour	All	1	19	106	0	0	0	92	0	0	0	0	0	0	18	236	0	
	HV	0	0	2	0	0	0	0	0	0	0	0	0	0	0	2	0	
	HV%	0%	0%	2%	-	-	-	0%	-	-	-	-	-	-	0%	1%	0	

Note: Six-hour count summary volumes include heavy vehicles but exclude bicycles in overall count.

Interval Start	Heavy Vehicle Totals					Bicycles					Pedestrians (Crossing Leg)				
	EB	WB	NB	SB	Total	EB	WB	NB	SB	Total	East	West	North	South	Total
10:00 AM	0	0	0	0	0	1	1	0	0	2	0	0	0	0	0
10:15 AM	0	0	0	0	0	0	0	0	0	0	0	0	1	0	1
10:30 AM	0	0	0	0	0	0	0	0	0	0	0	0	2	0	2
10:45 AM	0	0	0	0	0	0	0	0	0	0	0	0	2	0	2
11:00 AM	0	0	0	0	0	1	2	0	0	3	0	0	1	0	1
11:15 AM	0	0	0	0	0	1	2	0	0	3	0	0	1	0	1
11:30 AM	0	0	0	0	0	1	6	0	0	7	0	0	0	0	0
11:45 AM	0	0	0	0	0	0	0	0	0	0	0	0	0	0	0
12:00 PM	1	0	0	0	1	0	0	0	0	0	0	0	0	0	0
12:15 PM	0	0	0	0	0	0	0	0	0	0	0	0	0	0	0
12:30 PM	0	0	0	0	0	2	1	0	0	3	0	0	0	0	0
12:45 PM	0	0	0	0	0	1	0	0	0	1	0	0	0	0	0
1:00 PM	0	0	0	0	0	1	0	0	0	1	0	0	1	0	1
1:15 PM	1	0	0	0	1	0	1	0	0	1	0	0	0	0	0
1:30 PM	0	0	0	0	0	0	0	0	0	0	0	0	0	0	0
1:45 PM	1	0	0	0	1	0	2	0	0	2	0	0	0	0	0
2:00 PM	0	0	0	0	0	0	0	0	0	0	0	0	0	0	0
2:15 PM	0	0	0	0	0	2	0	0	0	2	0	0	2	0	2
2:30 PM	0	0	0	0	0	0	0	0	0	0	0	0	0	0	0
2:45 PM	0	0	0	0	0	0	1	0	0	1	0	0	0	0	0
3:00 PM	0	0	0	0	0	3	0	0	0	3	0	0	2	0	2
3:15 PM	0	0	0	0	0	0	0	0	0	0	0	0	0	0	0
3:30 PM	0	0	0	0	0	0	0	0	0	0	0	0	0	0	0
3:45 PM	0	1	0	0	1	0	0	0	0	0	0	0	1	0	1
Count Total	3	1	0	0	4	13	16	0	0	29	0	0	13	0	13
Peak Hr	2	0	0	0	2	0	3	0	0	3	0	0	0	0	0



Six-Hour Count Summaries - Heavy Vehicles																		
Interval Start	Shiloh Rd				Shiloh Rd				N/A				Gridley Dr				15-min Total	Rolling One Hour
	Eastbound				Westbound				Northbound				Southbound					
	UT	LT	TH	RT	UT	LT	TH	RT	UT	LT	TH	RT	UT	LT	TH	RT		
10:00 AM	0	0	0	0	0	0	0	0	0	0	0	0	0	0	0	0	0	
10:15 AM	0	0	0	0	0	0	0	0	0	0	0	0	0	0	0	0	0	
10:30 AM	0	0	0	0	0	0	0	0	0	0	0	0	0	0	0	0	0	
10:45 AM	0	0	0	0	0	0	0	0	0	0	0	0	0	0	0	0	0	
11:00 AM	0	0	0	0	0	0	0	0	0	0	0	0	0	0	0	0	0	
11:15 AM	0	0	0	0	0	0	0	0	0	0	0	0	0	0	0	0	0	
11:30 AM	0	0	0	0	0	0	0	0	0	0	0	0	0	0	0	0	0	
11:45 AM	0	0	0	0	0	0	0	0	0	0	0	0	0	0	0	0	0	
12:00 PM	0	0	1	0	0	0	0	0	0	0	0	0	0	0	0	1	1	
12:15 PM	0	0	0	0	0	0	0	0	0	0	0	0	0	0	0	0	1	
12:30 PM	0	0	0	0	0	0	0	0	0	0	0	0	0	0	0	0	1	
12:45 PM	0	0	0	0	0	0	0	0	0	0	0	0	0	0	0	0	1	
1:00 PM	0	0	0	0	0	0	0	0	0	0	0	0	0	0	0	0	0	
1:15 PM	0	0	1	0	0	0	0	0	0	0	0	0	0	0	0	1	1	
1:30 PM	0	0	0	0	0	0	0	0	0	0	0	0	0	0	0	0	1	
1:45 PM	0	0	1	0	0	0	0	0	0	0	0	0	0	0	0	1	2	
2:00 PM	0	0	0	0	0	0	0	0	0	0	0	0	0	0	0	0	2	
2:15 PM	0	0	0	0	0	0	0	0	0	0	0	0	0	0	0	0	1	
2:30 PM	0	0	0	0	0	0	0	0	0	0	0	0	0	0	0	0	1	
2:45 PM	0	0	0	0	0	0	0	0	0	0	0	0	0	0	0	0	0	
3:00 PM	0	0	0	0	0	0	0	0	0	0	0	0	0	0	0	0	0	
3:15 PM	0	0	0	0	0	0	0	0	0	0	0	0	0	0	0	0	0	
3:30 PM	0	0	0	0	0	0	0	0	0	0	0	0	0	0	0	0	0	
3:45 PM	0	0	0	0	0	0	1	0	0	0	0	0	0	0	0	1	1	
Count Total	0	0	3	0	0	0	1	0	0	0	0	0	0	0	0	4	0	
Peak Hour	0	0	2	0	0	0	0	0	0	0	0	0	0	0	0	2	0	

Six-Hour Count Summaries - Bikes																	
Interval Start	Shiloh Rd			Shiloh Rd			N/A			Gridley Dr			15-min Total	Rolling One Hour			
	Eastbound			Westbound			Northbound			Southbound							
	LT	TH	RT	LT	TH	RT	LT	TH	RT	LT	TH	RT					
10:00 AM	0	1	0	0	1	0	0	0	0	0	0	0	2	0			
10:15 AM	0	0	0	0	0	0	0	0	0	0	0	0	0	0			
10:30 AM	0	0	0	0	0	0	0	0	0	0	0	0	0	0			
10:45 AM	0	0	0	0	0	0	0	0	0	0	0	0	0	2			
11:00 AM	0	1	0	0	2	0	0	0	0	0	0	0	3	3			
11:15 AM	0	1	0	1	1	0	0	0	0	0	0	0	3	6			
11:30 AM	0	1	0	0	6	0	0	0	0	0	0	0	7	13			
11:45 AM	0	0	0	0	0	0	0	0	0	0	0	0	0	13			
12:00 PM	0	0	0	0	0	0	0	0	0	0	0	0	0	10			
12:15 PM	0	0	0	0	0	0	0	0	0	0	0	0	0	7			
12:30 PM	0	2	0	0	1	0	0	0	0	0	0	0	3	3			
12:45 PM	0	1	0	0	0	0	0	0	0	0	0	0	1	4			
1:00 PM	0	1	0	0	0	0	0	0	0	0	0	0	1	5			
1:15 PM	0	0	0	0	1	0	0	0	0	0	0	0	1	6			
1:30 PM	0	0	0	0	0	0	0	0	0	0	0	0	0	3			
1:45 PM	0	0	0	0	2	0	0	0	0	0	0	0	2	4			
2:00 PM	0	0	0	0	0	0	0	0	0	0	0	0	0	3			
2:15 PM	0	2	0	0	0	0	0	0	0	0	0	0	2	4			
2:30 PM	0	0	0	0	0	0	0	0	0	0	0	0	0	4			
2:45 PM	0	0	0	0	1	0	0	0	0	0	0	0	1	3			
3:00 PM	0	3	0	0	0	0	0	0	0	0	0	0	3	6			
3:15 PM	0	0	0	0	0	0	0	0	0	0	0	0	0	4			
3:30 PM	0	0	0	0	0	0	0	0	0	0	0	0	0	4			
3:45 PM	0	0	0	0	0	0	0	0	0	0	0	0	0	3			
Count Total	0	13	0	1	15	0	0	0	0	0	0	0	29	0			
Peak Hour	0	0	0	0	3	0	0	0	0	0	0	0	3	0			

Note: U-Turn volumes for bikes are included in Left-Turn, if any.

## Old Redwood Hwy Shiloh Neighborhood Church South



Date: 07/30/2022  
Count Period: 10:00 AM to 4:00 PM  
Peak Hour: 11:30 AM to 12:30 PM

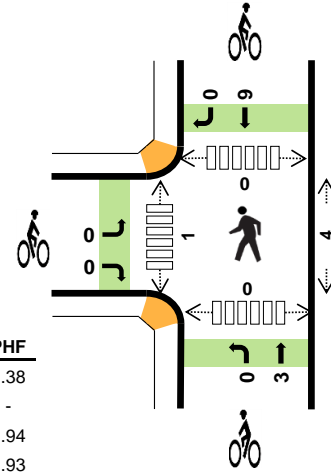
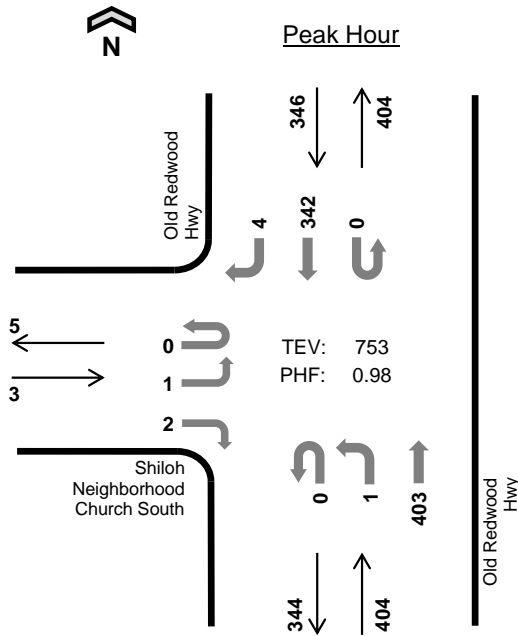

	HV %:	PHF
EB	0.0%	0.38
WB	-	-
NB	1.0%	0.94
SB	2.0%	0.93
TOTAL	1.5%	0.98

### Six-Hour Count Summaries

Interval Start	Shiloh Neighborhood Church South				n/a				Old Redwood Hwy				Old Redwood Hwy				15-min Total	Rolling One Hour	
	Eastbound				Westbound				Northbound				Southbound						
	UT	LT	TH	RT	UT	LT	TH	RT	UT	LT	TH	RT	UT	LT	TH	RT			
11:30 AM	0	1	0	0	0	0	0	0	0	0	92	0	0	0	90	0	183	0	
11:45 AM	0	0	0	0	0	0	0	0	0	0	107	0	0	0	81	2	190	0	
12:00 PM	0	0	0	2	0	0	0	0	0	0	106	0	0	0	78	2	188	0	
12:15 PM	0	0	0	0	0	0	0	0	0	1	98	0	0	0	93	0	192	753	
Peak Hour	All	0	1	0	2	0	0	0	0	0	1	403	0	0	0	342	4	753	0
	HV	0	0	0	0	0	0	0	0	0	0	4	0	0	0	7	0	11	0
	HV%	-	0%	-	0%	-	-	-	-	-	0%	1%	-	-	-	2%	0%	1%	0

Note: For all three-hour count summary, see next page.

Interval Start	Heavy Vehicle Totals					Bicycles					Pedestrians (Crossing Leg)				
	EB	WB	NB	SB	Total	EB	WB	NB	SB	Total	East	West	North	South	Total
11:30 AM	0	0	1	3	4	0	0	2	3	5	2	0	0	0	2
11:45 AM	0	0	1	2	3	0	0	1	4	5	2	0	0	0	2
12:00 PM	0	0	1	1	2	0	0	0	1	1	0	0	0	0	0
12:15 PM	0	0	1	1	2	0	0	0	1	1	0	1	0	0	1
Peak Hour	0	0	4	7	11	0	0	3	9	12	4	1	0	0	5

Six-Hour Count Summaries																			
Interval Start	Shiloh Neighborhood Church South				n/a				Old Redwood Hwy				Old Redwood Hwy				15-min Total	Rolling One Hour	
	Eastbound				Westbound				Northbound				Southbound						
	UT	LT	TH	RT	UT	LT	TH	RT	UT	LT	TH	RT	UT	LT	TH	RT			
10:00 AM	0	0	0	0	0	0	0	0	0	1	58	0	0	0	84	1	144	0	
10:15 AM	0	0	0	0	0	0	0	0	0	1	82	0	0	0	82	1	166	0	
10:30 AM	0	0	0	1	0	0	0	0	0	2	71	0	0	0	96	1	171	0	
10:45 AM	0	1	0	0	0	0	0	0	0	0	84	0	0	0	78	0	163	644	
11:00 AM	0	0	0	0	0	0	0	0	0	1	90	0	0	0	84	1	176	676	
11:15 AM	0	2	0	2	0	0	0	0	0	0	74	0	0	0	87	1	166	676	
11:30 AM	0	1	0	0	0	0	0	0	0	0	92	0	0	0	90	0	183	688	
11:45 AM	0	0	0	0	0	0	0	0	0	0	107	0	0	0	81	2	190	715	
12:00 PM	0	0	0	2	0	0	0	0	0	0	106	0	0	0	78	2	188	727	
12:15 PM	0	0	0	0	0	0	0	0	0	1	98	0	0	0	93	0	192	753	
12:30 PM	0	1	0	0	0	0	0	0	0	0	85	0	0	0	72	0	158	728	
12:45 PM	0	0	0	0	0	0	0	0	0	0	82	0	0	0	84	1	167	705	
1:00 PM	0	3	0	0	0	0	0	0	0	0	86	0	0	0	90	0	179	696	
1:15 PM	0	0	0	2	0	0	0	0	0	0	85	0	0	0	98	0	185	689	
1:30 PM	0	0	0	0	0	0	0	0	0	0	71	0	0	0	92	0	163	694	
1:45 PM	0	0	0	0	0	0	0	0	0	0	97	0	0	0	93	0	190	717	
2:00 PM	0	2	0	7	0	0	0	0	0	0	91	0	0	0	82	0	182	720	
2:15 PM	0	2	0	8	0	0	0	0	0	0	81	0	0	0	85	0	176	711	
2:30 PM	0	9	0	13	0	0	0	0	0	0	73	0	0	0	77	1	173	721	
2:45 PM	0	0	0	8	0	0	0	0	0	0	71	0	0	0	79	1	159	690	
3:00 PM	0	0	0	0	0	0	0	0	0	0	72	0	0	0	88	0	160	668	
3:15 PM	0	0	0	2	0	0	0	0	0	0	76	0	0	0	91	0	169	661	
3:30 PM	0	0	0	1	0	0	0	0	0	0	84	0	0	0	80	0	165	653	
3:45 PM	0	1	0	1	0	0	0	0	0	0	81	0	0	0	56	0	139	633	
Count Total	0	22	0	47	0	0	0	0	0	6	1,997	0	0	0	2,020	12	4,104	0	
Peak Hour	All	0	1	0	2	0	0	0	0	0	1	403	0	0	0	342	4	753	0
	HV	0	0	0	0	0	0	0	0	0	0	4	0	0	0	7	0	11	0
	HV%	-	0%	-	0%	-	-	-	-	-	0%	1%	-	-	-	2%	0%	1%	0
Note: Six-hour count summary volumes include heavy vehicles but exclude bicycles in overall count.																			
Interval Start	Heavy Vehicle Totals					Bicycles					Pedestrians (Crossing Leg)								
	EB	WB	NB	SB	Total	EB	WB	NB	SB	Total	East	West	North	South	Total				
10:00 AM	0	0	0	1	1	0	0	0	1	1	0	1	0	0	1				
10:15 AM	0	0	3	0	3	0	0	6	1	7	3	0	0	0	3				
10:30 AM	0	0	1	2	3	0	0	0	1	1	0	1	0	0	1				
10:45 AM	0	0	0	1	1	0	0	2	0	2	3	1	1	0	5				
11:00 AM	0	0	1	3	4	0	0	2	0	2	2	0	0	0	2				
11:15 AM	0	0	1	0	1	0	0	0	3	3	0	0	0	0	0				
11:30 AM	0	0	1	3	4	0	0	2	3	5	2	0	0	0	2				
11:45 AM	0	0	1	2	3	0	0	1	4	5	2	0	0	0	2				
12:00 PM	0	0	1	1	2	0	0	0	1	1	0	0	0	0	0				
12:15 PM	0	0	1	1	2	0	0	0	1	1	0	1	0	0	1				
12:30 PM	0	0	0	2	2	0	0	2	5	7	2	0	0	0	2				
12:45 PM	0	0	0	2	2	0	0	0	1	1	1	0	0	0	1				
1:00 PM	0	0	3	2	5	0	0	2	2	4	2	0	0	0	2				
1:15 PM	0	0	5	3	8	0	0	1	2	3	1	0	0	0	1				
1:30 PM	0	0	2	3	5	0	0	0	5	5	0	0	0	0	0				
1:45 PM	0	0	1	4	5	0	0	1	0	1	1	0	0	0	1				
2:00 PM	0	0	1	1	2	0	0	2	0	2	1	0	0	0	1				
2:15 PM	0	0	2	1	3	0	0	2	0	2	2	0	0	0	2				
2:30 PM	0	0	1	1	2	0	0	0	0	0	0	0	0	0	0				
2:45 PM	0	0	1	4	5	0	0	1	0	1	0	0	0	0	0				
3:00 PM	0	0	2	1	3	0	0	0	1	1	1	0	0	0	1				
3:15 PM	0	0	2	3	5	0	0	1	0	1	1	0	0	0	1				
3:30 PM	0	0	1	2	3	0	0	0	2	2	0	0	0	0	0				
3:45 PM	0	0	0	1	1	0	0	0	0	0	0	0	0	0	0				
Count Total	0	0	31	44	75	0	0	25	33	58	24	4	1	0	29				
Peak Hr	0	0	4	7	11	0	0	3	9	12	4	1	0	0	5				

Six-Hour Count Summaries - Heavy Vehicles																		
Interval Start	Shiloh Neighborhood Church South				n/a				Old Redwood Hwy				Old Redwood Hwy				15-min Total	Rolling One Hour
	Eastbound				Westbound				Northbound				Southbound					
	UT	LT	TH	RT	UT	LT	TH	RT	UT	LT	TH	RT	UT	LT	TH	RT		
10:00 AM	0	0	0	0	0	0	0	0	0	0	0	0	0	0	1	0	1	0
10:15 AM	0	0	0	0	0	0	0	0	0	0	3	0	0	0	0	0	3	0
10:30 AM	0	0	0	0	0	0	0	0	0	0	1	0	0	0	2	0	3	0
10:45 AM	0	0	0	0	0	0	0	0	0	0	0	0	0	0	1	0	1	8
11:00 AM	0	0	0	0	0	0	0	0	0	0	1	0	0	0	3	0	4	11
11:15 AM	0	0	0	0	0	0	0	0	0	0	1	0	0	0	0	0	1	9
11:30 AM	0	0	0	0	0	0	0	0	0	0	1	0	0	0	3	0	4	10
11:45 AM	0	0	0	0	0	0	0	0	0	0	1	0	0	0	2	0	3	12
12:00 PM	0	0	0	0	0	0	0	0	0	0	1	0	0	0	1	0	2	10
12:15 PM	0	0	0	0	0	0	0	0	0	0	1	0	0	0	1	0	2	11
12:30 PM	0	0	0	0	0	0	0	0	0	0	0	0	0	0	2	0	2	9
12:45 PM	0	0	0	0	0	0	0	0	0	0	0	0	0	0	2	0	2	8
1:00 PM	0	0	0	0	0	0	0	0	0	0	3	0	0	0	2	0	5	11
1:15 PM	0	0	0	0	0	0	0	0	0	0	5	0	0	0	3	0	8	17
1:30 PM	0	0	0	0	0	0	0	0	0	0	2	0	0	0	3	0	5	20
1:45 PM	0	0	0	0	0	0	0	0	0	0	1	0	0	0	4	0	5	23
2:00 PM	0	0	0	0	0	0	0	0	0	0	1	0	0	0	1	0	2	20
2:15 PM	0	0	0	0	0	0	0	0	0	0	2	0	0	0	1	0	3	15
2:30 PM	0	0	0	0	0	0	0	0	0	0	1	0	0	0	1	0	2	12
2:45 PM	0	0	0	0	0	0	0	0	0	0	1	0	0	0	4	0	5	12
3:00 PM	0	0	0	0	0	0	0	0	0	0	2	0	0	0	1	0	3	13
3:15 PM	0	0	0	0	0	0	0	0	0	0	2	0	0	0	3	0	5	15
3:30 PM	0	0	0	0	0	0	0	0	0	0	1	0	0	0	2	0	3	16
3:45 PM	0	0	0	0	0	0	0	0	0	0	0	0	0	0	1	0	1	12
Count Total	0	0	0	0	0	0	0	0	0	0	31	0	0	0	44	0	75	0
Peak Hour	0	0	0	0	0	0	0	0	0	0	4	0	0	0	7	0	11	0

Six-Hour Count Summaries - Bikes																		
Interval Start	Shiloh Neighborhood Church South				n/a				Old Redwood Hwy				Old Redwood Hwy				15-min Total	Rolling One Hour
	Eastbound				Westbound				Northbound				Southbound					
	LT	TH	RT		LT	TH	RT		LT	TH	RT		LT	TH	RT			
10:00 AM	0	0	0		0	0	0		0	0	0		0	1	0		1	0
10:15 AM	0	0	0		0	0	0		0	6	0		0	1	0		7	0
10:30 AM	0	0	0		0	0	0		0	0	0		0	1	0		1	0
10:45 AM	0	0	0		0	0	0		0	2	0		0	0	0		2	11
11:00 AM	0	0	0		0	0	0		0	2	0		0	0	0		2	12
11:15 AM	0	0	0		0	0	0		0	0	0		0	3	0		3	8
11:30 AM	0	0	0		0	0	0		0	2	0		0	3	0		5	12
11:45 AM	0	0	0		0	0	0		0	1	0		0	4	0		5	15
12:00 PM	0	0	0		0	0	0		0	0	0		0	1	0		1	14
12:15 PM	0	0	0		0	0	0		0	0	0		0	1	0		1	12
12:30 PM	0	0	0		0	0	0		0	2	0		0	5	0		7	14
12:45 PM	0	0	0		0	0	0		0	0	0		0	1	0		1	10
1:00 PM	0	0	0		0	0	0		0	2	0		0	2	0		4	13
1:15 PM	0	0	0		0	0	0		0	1	0		0	2	0		3	15
1:30 PM	0	0	0		0	0	0		0	0	0		0	5	0		5	13
1:45 PM	0	0	0		0	0	0		0	1	0		0	0	0		1	13
2:00 PM	0	0	0		0	0	0		0	2	0		0	0	0		2	11
2:15 PM	0	0	0		0	0	0		0	2	0		0	0	0		2	10
2:30 PM	0	0	0		0	0	0		0	0	0		0	0	0		0	5
2:45 PM	0	0	0		0	0	0		0	1	0		0	0	0		1	5
3:00 PM	0	0	0		0	0	0		0	0	0		0	1	0		1	4
3:15 PM	0	0	0		0	0	0		0	1	0		0	0	0		1	3
3:30 PM	0	0	0		0	0	0		0	0	0		0	2	0		2	5
3:45 PM	0	0	0		0	0	0		0	0	0		0	0	0		0	4
Count Total	0	0	0		0	0	0		0	25	0		0	33	0		58	0
Peak Hour	0	0	0		0	0	0		0	3	0		0	9	0		12	0

Note: U-Turn volumes for bikes are included in Left-Turn, if any.

# Driveway (East of Caporale Ct) Shiloh Rd



Peak Hour

Date: 07/30/2022  
 Count Period: 10:00 AM to 4:00 PM  
 Peak Hour: 1:15 PM to 2:15 PM

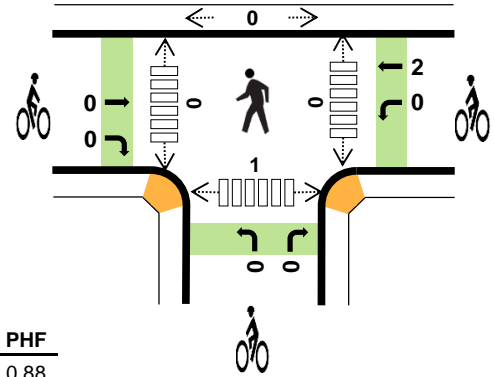
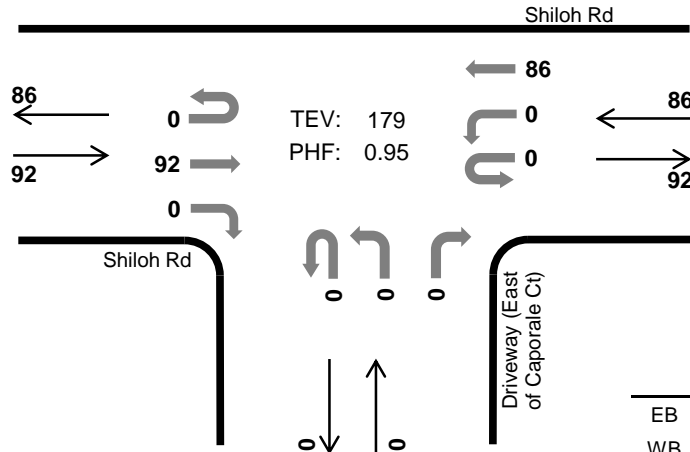

	HV %:	PHF
EB	1.1%	0.88
WB	0.0%	0.80
NB	-	-
SB	-	0.25
TOTAL	0.6%	0.95

## Six-Hour Count Summaries

Interval Start	Shiloh Rd				Shiloh Rd				Driveway (East of Caporale Ct)				n/a				15-min Total	Rolling One Hour
	Eastbound				Westbound				Northbound				Southbound					
	UT	LT	TH	RT	UT	LT	TH	RT	UT	LT	TH	RT	UT	LT	TH	RT		
1:15 PM	0	0	25	0	0	0	19	0	0	0	0	0	0	0	0	0	44	0
1:30 PM	0	0	21	0	0	0	19	0	0	0	0	0	0	0	0	0	40	0
1:45 PM	0	0	26	0	0	0	21	0	0	0	0	0	0	0	0	0	47	0
2:00 PM	0	0	20	0	0	0	27	0	0	0	0	0	0	0	0	0	47	178
Peak Hour	All	0	0	92	0	0	86	0	0	0	0	0	0	0	0	0	178	0
	HV	0	0	1	0	0	0	0	0	0	0	0	0	0	0	0	1	0
	HV%	-	-	1%	-	-	0%	-	-	-	-	-	-	-	-	-	1%	0

Note: For all three-hour count summary, see next page.

Interval Start	Heavy Vehicle Totals					Bicycles					Pedestrians (Crossing Leg)				
	EB	WB	NB	SB	Total	EB	WB	NB	SB	Total	East	West	North	South	Total
1:15 PM	0	0	0	0	0	0	1	0	0	1	0	0	0	0	0
1:30 PM	0	0	0	0	0	0	0	0	0	0	0	0	0	0	0
1:45 PM	1	0	0	0	1	0	1	0	0	1	0	0	0	0	0
2:00 PM	0	0	0	0	0	0	0	0	0	0	0	0	0	1	1
Peak Hour	1	0	0	0	1	0	2	0	0	2	0	0	0	1	1

**Six-Hour Count Summaries**

Interval Start	Shiloh Rd				Shiloh Rd				Driveway (East of Caporale Ct)				n/a				15-min Total	Rolling One Hour
	Eastbound				Westbound				Northbound				Southbound					
	UT	LT	TH	RT	UT	LT	TH	RT	UT	LT	TH	RT	UT	LT	TH	RT		
10:00 AM	0	0	17	0	0	0	20	0	0	0	0	0	0	0	0	37	0	
10:15 AM	0	0	20	0	0	0	28	0	0	0	0	0	0	0	0	48	0	
10:30 AM	0	0	19	0	0	0	15	0	0	0	0	0	0	0	0	34	0	
10:45 AM	0	0	25	0	0	0	18	0	0	0	0	0	0	0	0	43	162	
11:00 AM	0	0	27	0	0	0	20	0	0	0	0	0	0	0	0	47	172	
11:15 AM	0	0	17	0	0	0	17	0	0	0	0	0	0	0	0	34	158	
11:30 AM	0	0	21	0	0	0	23	0	0	0	0	0	0	0	0	44	168	
11:45 AM	0	0	22	0	0	0	19	0	0	0	0	0	0	0	0	41	166	
12:00 PM	0	0	25	0	0	0	20	0	0	0	0	0	0	0	0	45	164	
12:15 PM	0	0	16	0	0	0	21	0	0	0	0	0	0	0	0	37	167	
12:30 PM	0	0	13	0	0	0	22	0	0	0	0	0	0	0	0	35	158	
12:45 PM	0	0	16	0	0	0	28	0	0	0	0	0	0	0	0	44	161	
1:00 PM	0	0	24	0	0	0	19	0	0	0	0	0	0	0	0	43	159	
1:15 PM	0	0	25	0	0	0	19	0	0	0	0	0	0	0	0	44	166	
1:30 PM	0	0	21	0	0	0	19	0	0	0	0	0	0	1	0	41	172	
1:45 PM	0	0	26	0	0	0	21	0	0	0	0	0	0	0	0	47	175	
2:00 PM	0	0	20	0	0	0	27	0	0	0	0	0	0	0	0	47	179	
2:15 PM	0	0	16	0	0	0	20	0	0	0	0	0	0	0	0	36	171	
2:30 PM	0	0	16	0	0	0	18	0	0	0	0	0	0	0	0	34	164	
2:45 PM	0	0	15	0	0	0	23	0	0	0	0	0	0	0	0	38	155	
3:00 PM	0	1	12	0	0	0	23	0	0	0	0	0	0	0	0	36	144	
3:15 PM	0	0	13	0	0	0	19	0	0	0	0	0	0	0	0	32	140	
3:30 PM	0	0	13	0	0	0	17	0	0	0	0	0	0	0	0	30	136	
3:45 PM	0	0	16	0	0	0	31	0	0	0	0	0	0	0	0	47	145	
Count Total	0	1	455	0	0	0	507	0	0	0	0	0	0	0	0	963	0	
Peak Hour	All	0	0	92	0	0	0	86	0	0	0	0	0	0	0	178	0	
	HV	0	0	1	0	0	0	0	0	0	0	0	0	0	0	1	0	
	HV%	-	-	1%	-	-	-	0%	-	-	-	-	-	-	-	1%	0	

Note: Six-hour count summary volumes include heavy vehicles but exclude bicycles in overall count.

Interval Start	Heavy Vehicle Totals					Bicycles					Pedestrians (Crossing Leg)				
	EB	WB	NB	SB	Total	EB	WB	NB	SB	Total	East	West	North	South	Total
10:00 AM	0	0	0	0	0	1	1	0	0	2	0	0	1	0	1
10:15 AM	0	0	0	0	0	0	0	0	0	0	0	0	0	1	1
10:30 AM	0	0	0	0	0	0	0	0	0	0	0	0	2	0	2
10:45 AM	0	0	0	0	0	0	0	0	0	0	0	0	1	0	1
11:00 AM	1	1	0	0	2	1	2	0	0	3	0	0	0	0	0
11:15 AM	0	0	0	0	0	1	2	0	0	3	0	0	0	0	0
11:30 AM	0	0	0	0	0	2	5	0	0	7	0	0	0	0	0
11:45 AM	0	0	0	0	0	0	0	0	0	0	0	0	0	0	0
12:00 PM	0	0	0	0	0	0	0	0	0	0	0	0	0	0	0
12:15 PM	0	0	0	0	0	0	0	0	0	0	0	0	0	0	0
12:30 PM	0	0	0	0	0	1	1	0	0	2	0	0	0	0	0
12:45 PM	0	0	0	0	0	1	0	0	0	1	0	0	0	0	0
1:00 PM	1	1	0	0	2	2	0	0	0	2	0	0	0	0	0
1:15 PM	0	0	0	0	0	0	1	0	0	1	0	0	0	0	0
1:30 PM	0	0	0	0	0	0	0	0	0	0	0	0	0	0	0
1:45 PM	1	0	0	0	1	0	1	0	0	1	0	0	0	0	0
2:00 PM	0	0	0	0	0	0	0	0	0	0	0	0	0	1	1
2:15 PM	0	0	0	0	0	2	0	0	0	2	0	0	0	1	1
2:30 PM	0	1	0	0	1	0	0	0	0	0	0	0	1	0	1
2:45 PM	0	0	0	0	0	0	1	0	0	1	0	0	0	0	0
3:00 PM	0	0	0	0	0	3	0	0	0	3	0	0	0	0	0
3:15 PM	0	0	0	0	0	0	0	0	0	0	0	0	0	0	0
3:30 PM	0	0	0	0	0	0	0	0	0	0	0	0	1	0	1

3:45 PM	0	1	0	0	1	0	0	0	0	0	0	0	0	0	0
Count Total	3	4	0	0	7	14	14	0	0	28	0	0	6	3	9
Peak Hr	1	0	0	0	1	0	2	0	0	2	0	0	0	1	1

### Six-Hour Count Summaries - Heavy Vehicles

Interval Start	Shiloh Rd				Shiloh Rd				Driveway (East of Caporale Ct)				n/a				15-min Total	Rolling One Hour
	Eastbound				Westbound				Northbound				Southbound					
	UT	LT	TH	RT	UT	LT	TH	RT	UT	LT	TH	RT	UT	LT	TH	RT		
10:00 AM	0	0	0	0	0	0	0	0	0	0	0	0	0	0	0	0	0	
10:15 AM	0	0	0	0	0	0	0	0	0	0	0	0	0	0	0	0	0	
10:30 AM	0	0	0	0	0	0	0	0	0	0	0	0	0	0	0	0	0	
10:45 AM	0	0	0	0	0	0	0	0	0	0	0	0	0	0	0	0	0	
11:00 AM	0	0	1	0	0	0	1	0	0	0	0	0	0	0	0	2	2	
11:15 AM	0	0	0	0	0	0	0	0	0	0	0	0	0	0	0	0	2	
11:30 AM	0	0	0	0	0	0	0	0	0	0	0	0	0	0	0	0	2	
11:45 AM	0	0	0	0	0	0	0	0	0	0	0	0	0	0	0	0	2	
12:00 PM	0	0	0	0	0	0	0	0	0	0	0	0	0	0	0	0	0	
12:15 PM	0	0	0	0	0	0	0	0	0	0	0	0	0	0	0	0	0	
12:30 PM	0	0	0	0	0	0	0	0	0	0	0	0	0	0	0	0	0	
12:45 PM	0	0	0	0	0	0	0	0	0	0	0	0	0	0	0	0	0	
1:00 PM	0	0	1	0	0	0	1	0	0	0	0	0	0	0	0	2	2	
1:15 PM	0	0	0	0	0	0	0	0	0	0	0	0	0	0	0	0	2	
1:30 PM	0	0	0	0	0	0	0	0	0	0	0	0	0	0	0	0	2	
1:45 PM	0	0	1	0	0	0	0	0	0	0	0	0	0	0	0	1	3	
2:00 PM	0	0	0	0	0	0	0	0	0	0	0	0	0	0	0	0	1	
2:15 PM	0	0	0	0	0	0	0	0	0	0	0	0	0	0	0	0	1	
2:30 PM	0	0	0	0	0	0	1	0	0	0	0	0	0	0	0	1	2	
2:45 PM	0	0	0	0	0	0	0	0	0	0	0	0	0	0	0	0	1	
3:00 PM	0	0	0	0	0	0	0	0	0	0	0	0	0	0	0	0	1	
3:15 PM	0	0	0	0	0	0	0	0	0	0	0	0	0	0	0	0	1	
3:30 PM	0	0	0	0	0	0	0	0	0	0	0	0	0	0	0	0	0	
3:45 PM	0	0	0	0	0	0	1	0	0	0	0	0	0	0	0	1	1	
Count Total	0	0	3	0	0	0	4	0	0	0	0	0	0	0	0	7	0	
Peak Hour	0	0	1	0	0	0	0	0	0	0	0	0	0	0	0	1	0	

### Six-Hour Count Summaries - Bikes

Interval Start	Shiloh Rd			Shiloh Rd			Driveway (East of Caporale Ct)			n/a			15-min Total	Rolling One Hour
	Eastbound			Westbound			Northbound			Southbound				
	LT	TH	RT	LT	TH	RT	LT	TH	RT	LT	TH	RT		
10:00 AM	0	1	0	0	1	0	0	0	0	0	0	0	2	0
10:15 AM	0	0	0	0	0	0	0	0	0	0	0	0	0	0
10:30 AM	0	0	0	0	0	0	0	0	0	0	0	0	0	0
10:45 AM	0	0	0	0	0	0	0	0	0	0	0	0	0	2
11:00 AM	0	1	0	0	2	0	0	0	0	0	0	0	3	3
11:15 AM	0	1	0	0	2	0	0	0	0	0	0	0	3	6
11:30 AM	0	2	0	0	5	0	0	0	0	0	0	0	7	13
11:45 AM	0	0	0	0	0	0	0	0	0	0	0	0	0	13
12:00 PM	0	0	0	0	0	0	0	0	0	0	0	0	0	10
12:15 PM	0	0	0	0	0	0	0	0	0	0	0	0	0	7
12:30 PM	0	1	0	0	1	0	0	0	0	0	0	0	2	2
12:45 PM	0	1	0	0	0	0	0	0	0	0	0	0	1	3
1:00 PM	0	2	0	0	0	0	0	0	0	0	0	0	2	5
1:15 PM	0	0	0	0	1	0	0	0	0	0	0	0	1	6
1:30 PM	0	0	0	0	0	0	0	0	0	0	0	0	0	4
1:45 PM	0	0	0	0	1	0	0	0	0	0	0	0	1	4
2:00 PM	0	0	0	0	0	0	0	0	0	0	0	0	0	2
2:15 PM	0	2	0	0	0	0	0	0	0	0	0	0	2	3
2:30 PM	0	0	0	0	0	0	0	0	0	0	0	0	0	3
2:45 PM	0	0	0	0	1	0	0	0	0	0	0	0	1	3
3:00 PM	0	3	0	0	0	0	0	0	0	0	0	0	3	6



3:15 PM	0	0	0	0	0	0	0	0	0	0	0	0	0	4
3:30 PM	0	0	0	0	0	0	0	0	0	0	0	0	0	4
3:45 PM	0	0	0	0	0	0	0	0	0	0	0	0	0	3
Count Total	0	14	0	0	14	0	0	0	0	0	0	0	28	0
<b>Peak Hour</b>	<b>0</b>	<b>0</b>	<b>0</b>	<b>0</b>	<b>2</b>	<b>0</b>	<b>0</b>	<b>0</b>	<b>0</b>	<b>0</b>	<b>0</b>	<b>0</b>	<b>2</b>	<b>0</b>

Note: U-Turn volumes for bikes are included in Left-Turn, if any.

# US-101 NB Ramps Old Redwood Hwy



Date: 07/30/2022  
 Count Period: 10:00 AM to 4:00 PM  
 Peak Hour: 11:45 AM to 12:45 PM

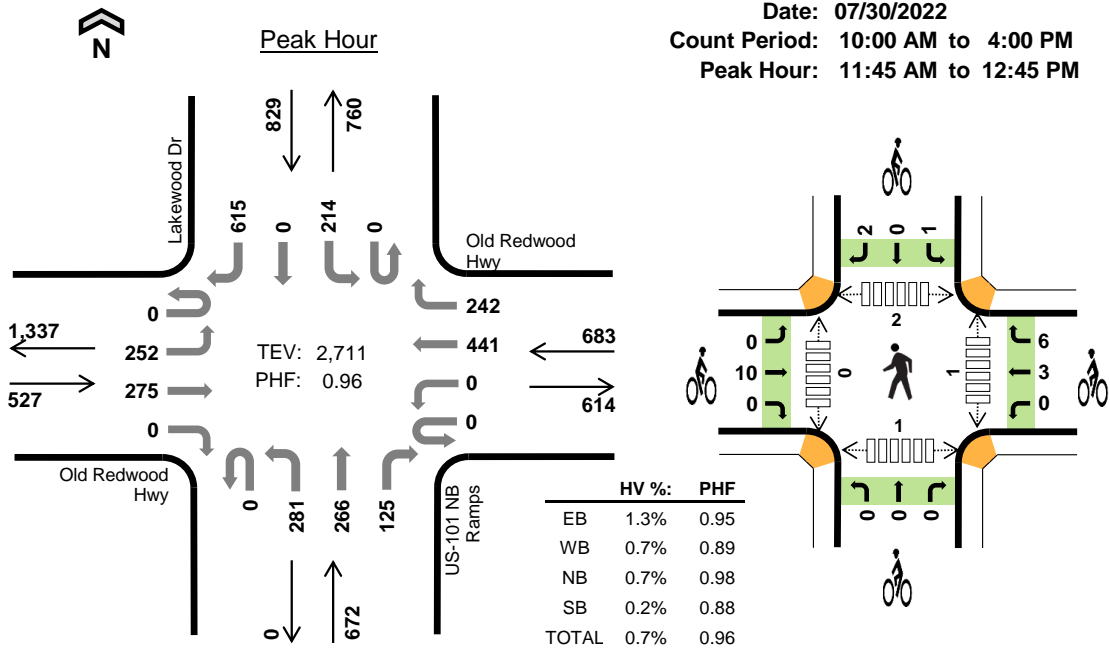

### Six-Hour Count Summaries

Interval Start	Old Redwood Hwy				Old Redwood Hwy				US-101 NB Ramps				Lakewood Dr				15-min Total	Rolling One Hour	
	Eastbound		Westbound		Northbound		Southbound		UT	LT	TH	RT	UT	LT	TH	RT			
11:45 AM	0	60	74	0	0	0	125	66	0	69	71	26	0	50	0	166	707	0	
12:00 PM	0	72	66	0	0	0	87	50	0	76	62	33	0	63	0	172	681	0	
12:15 PM	0	61	71	0	0	0	121	57	0	63	69	35	0	51	0	118	646	0	
12:30 PM	0	59	64	0	0	0	108	69	0	73	64	31	0	50	0	159	677	2,711	
Peak Hour	All	0	252	275	0	0	0	441	242	0	281	266	125	0	214	0	615	2,711	0
	HV	0	2	5	0	0	0	5	0	0	3	0	2	0	0	0	2	19	0
	HV%	-	1%	2%	-	-	-	1%	0%	-	1%	0%	2%	-	0%	-	0%	1%	0

Note: For all three-hour count summary, see next page.

Interval Start	Heavy Vehicle Totals					Bicycles					Pedestrians (Crossing Leg)				
	EB	WB	NB	SB	Total	EB	WB	NB	SB	Total	East	West	North	South	Total
11:45 AM	3	3	1	0	7	0	2	0	0	2	0	0	0	0	0
12:00 PM	1	1	1	0	3	4	2	0	1	7	0	0	1	0	1
12:15 PM	1	1	3	0	5	0	3	0	2	5	1	0	1	0	2
12:30 PM	2	0	0	2	4	6	2	0	0	8	0	0	0	1	1
Peak Hour	7	5	5	2	19	10	9	0	3	22	1	0	2	1	4

Six-Hour Count Summaries																			
Interval Start	Old Redwood Hwy				Old Redwood Hwy				US-101 NB Ramps				Lakewood Dr				15-min Total	Rolling One Hour	
	UT	Eastbound		RT	UT	Westbound		RT	UT	Northbound		RT	UT	Southbound		RT			
10:00 AM	0	49	54	0	0	0	98	44	0	58	57	14	0	48	0	113	535	0	
10:15 AM	0	54	45	0	0	0	93	56	0	58	56	20	0	37	0	134	553	0	
10:30 AM	0	47	51	0	0	0	101	46	0	65	41	19	0	53	0	144	567	0	
10:45 AM	0	67	53	0	0	0	91	72	0	58	74	32	0	47	0	154	648	2,303	
11:00 AM	0	65	62	0	0	0	93	55	0	93	47	23	0	49	0	136	623	2,391	
11:15 AM	0	58	57	0	0	0	83	48	0	63	66	32	0	52	0	149	608	2,446	
11:30 AM	0	64	73	0	0	0	103	63	0	66	54	32	0	49	0	146	650	2,529	
<b>11:45 AM</b>	<b>0</b>	<b>60</b>	<b>74</b>	<b>0</b>	<b>0</b>	<b>0</b>	<b>125</b>	<b>66</b>	<b>0</b>	<b>69</b>	<b>71</b>	<b>26</b>	<b>0</b>	<b>50</b>	<b>0</b>	<b>166</b>	<b>707</b>	<b>2,588</b>	
12:00 PM	0	72	66	0	0	0	87	50	0	76	62	33	0	63	0	172	681	2,646	
12:15 PM	0	61	71	0	0	0	121	57	0	63	69	35	0	51	0	118	646	2,684	
12:30 PM	0	59	64	0	0	0	108	69	0	73	64	31	0	50	0	159	677	2,711	
12:45 PM	0	57	52	0	0	0	104	47	0	81	85	40	0	58	0	134	658	2,662	
1:00 PM	0	52	59	0	0	0	107	45	0	68	63	38	0	42	0	127	601	2,582	
1:15 PM	0	54	56	0	0	0	118	53	0	78	68	28	0	58	0	133	646	2,582	
1:30 PM	0	49	66	0	0	0	102	54	0	64	59	35	0	76	0	143	648	2,553	
1:45 PM	0	66	93	0	0	0	85	65	0	78	65	33	0	49	0	134	668	2,563	
2:00 PM	0	44	51	0	0	0	113	68	0	76	54	38	0	59	0	148	651	2,613	
2:15 PM	0	56	73	0	0	0	104	44	0	79	68	36	0	60	0	122	642	2,609	
2:30 PM	0	48	66	0	0	0	91	47	0	57	63	47	0	39	0	141	599	2,560	
2:45 PM	0	52	70	0	0	0	101	56	0	56	63	45	0	41	0	123	607	2,499	
3:00 PM	0	52	62	0	0	0	112	42	0	69	70	50	0	40	0	127	624	2,472	
3:15 PM	0	46	65	0	0	0	80	53	0	65	54	31	0	47	0	132	573	2,403	
3:30 PM	0	42	60	0	0	0	124	45	0	67	58	33	0	46	0	130	605	2,409	
3:45 PM	0	48	64	0	0	0	104	40	0	65	51	33	0	35	0	119	559	2,361	
Count Total	0	1,322	1,507	0	0	0	2,448	1,285	0	1,645	1,482	784	0	1,199	0	3,304	14,976	0	
Peak Hour	All	0	252	275	0	0	0	441	242	0	281	266	125	0	214	0	615	2,711	0
	HV	0	2	5	0	0	0	5	0	0	3	0	2	0	0	0	2	19	0
	HV%	-	1%	2%	-	-	-	1%	0%	-	1%	0%	2%	-	0%	-	0%	1%	0

Note: Six-hour count summary volumes include heavy vehicles but exclude bicycles in overall count.

Interval Start	Heavy Vehicle Totals					Bicycles					Pedestrians (Crossing Leg)				
	EB	WB	NB	SB	Total	EB	WB	NB	SB	Total	East	West	North	South	Total
10:00 AM	1	1	1	2	5	1	2	0	0	3	0	0	0	2	2
10:15 AM	2	2	2	1	7	1	2	0	0	3	0	0	1	1	2
10:30 AM	1	5	1	0	7	0	2	0	1	3	1	0	3	2	6
10:45 AM	2	2	0	3	7	0	0	0	0	0	2	0	1	0	3
11:00 AM	4	1	1	4	10	1	0	0	0	1	0	0	1	0	1
11:15 AM	10	0	2	2	14	1	0	0	2	3	1	0	3	0	4
11:30 AM	0	1	0	3	4	0	1	0	1	2	2	0	0	1	3
<b>11:45 AM</b>	<b>3</b>	<b>3</b>	<b>1</b>	<b>0</b>	<b>7</b>	<b>0</b>	<b>2</b>	<b>0</b>	<b>0</b>	<b>2</b>	<b>0</b>	<b>0</b>	<b>0</b>	<b>0</b>	<b>0</b>
12:00 PM	1	1	1	0	3	4	2	0	1	7	0	0	1	0	1
12:15 PM	1	1	3	0	5	0	3	0	2	5	1	0	1	0	2
12:30 PM	2	0	0	2	4	6	2	0	0	8	0	0	0	1	1
12:45 PM	1	3	5	0	9	1	1	0	1	3	1	0	1	0	2
1:00 PM	0	3	2	1	6	1	1	0	0	2	2	0	2	0	4
1:15 PM	1	1	0	2	4	1	4	0	0	5	0	0	0	2	2
1:30 PM	3	2	1	3	9	2	2	0	0	4	4	0	0	1	5
1:45 PM	2	1	1	0	4	3	2	0	0	5	1	0	3	1	5
2:00 PM	1	1	0	2	4	0	2	0	0	2	0	0	0	0	0
2:15 PM	1	2	2	2	7	0	3	0	0	3	0	0	0	0	0
2:30 PM	0	0	1	0	1	2	0	0	0	2	0	0	1	0	1
2:45 PM	0	1	1	0	2	4	0	0	1	5	0	0	0	0	0
3:00 PM	0	2	1	0	3	1	0	0	2	3	3	0	2	0	5
3:15 PM	2	1	1	1	5	2	1	0	0	3	0	0	3	0	3
3:30 PM	2	0	0	2	4	0	2	0	1	3	2	0	3	0	5
3:45 PM	3	3	3	1	10	2	0	0	1	3	0	0	1	1	2
Count Total	43	37	30	31	141	33	34	0	13	80	20	0	27	12	59
Peak Hour	7	5	5	2	19	10	9	0	3	22	1	0	2	1	4

<b>Six-Hour Count Summaries - Heavy Vehicles</b>																		
Interval Start	Old Redwood Hwy				Old Redwood Hwy				US-101 NB Ramps				Lakewood Dr				15-min Total	Rolling One Hour
	Eastbound				Westbound				Northbound				Southbound					
	UT	LT	TH	RT	UT	LT	TH	RT	UT	LT	TH	RT	UT	LT	TH	RT		
10:00 AM	0	1	0	0	0	0	1	0	0	0	0	1	0	1	0	1	5	0
10:15 AM	0	0	2	0	0	0	2	0	0	2	0	0	0	1	0	0	7	0
10:30 AM	0	1	0	0	0	0	5	0	0	0	0	1	0	0	0	0	7	0
10:45 AM	0	0	2	0	0	0	0	2	0	0	0	0	0	0	0	3	7	26
11:00 AM	0	1	3	0	0	0	0	1	0	1	0	0	0	0	0	4	10	31
11:15 AM	0	0	10	0	0	0	0	0	0	1	1	0	0	0	0	2	14	38
11:30 AM	0	0	0	0	0	0	1	0	0	0	0	0	0	0	0	3	4	35
<b>11:45 AM</b>	<b>0</b>	<b>0</b>	<b>3</b>	<b>0</b>	<b>0</b>	<b>0</b>	<b>3</b>	<b>0</b>	<b>0</b>	<b>1</b>	<b>0</b>	<b>0</b>	<b>0</b>	<b>0</b>	<b>0</b>	<b>7</b>	<b>7</b>	<b>35</b>
<b>12:00 PM</b>	<b>0</b>	<b>1</b>	<b>0</b>	<b>0</b>	<b>0</b>	<b>0</b>	<b>1</b>	<b>0</b>	<b>0</b>	<b>0</b>	<b>0</b>	<b>1</b>	<b>0</b>	<b>0</b>	<b>0</b>	<b>0</b>	<b>3</b>	<b>28</b>
<b>12:15 PM</b>	<b>0</b>	<b>1</b>	<b>0</b>	<b>0</b>	<b>0</b>	<b>0</b>	<b>1</b>	<b>0</b>	<b>0</b>	<b>2</b>	<b>0</b>	<b>1</b>	<b>0</b>	<b>0</b>	<b>0</b>	<b>0</b>	<b>5</b>	<b>19</b>
<b>12:30 PM</b>	<b>0</b>	<b>0</b>	<b>2</b>	<b>0</b>	<b>0</b>	<b>0</b>	<b>0</b>	<b>0</b>	<b>0</b>	<b>0</b>	<b>0</b>	<b>0</b>	<b>0</b>	<b>0</b>	<b>2</b>	<b>4</b>	<b>4</b>	<b>19</b>
12:45 PM	0	0	1	0	0	0	3	0	0	0	3	2	0	0	0	0	9	21
1:00 PM	0	0	0	0	0	0	2	1	0	1	1	0	0	0	0	1	6	24
1:15 PM	0	1	0	0	0	0	1	0	0	0	0	0	0	1	0	1	4	23
1:30 PM	0	1	2	0	0	0	2	0	0	1	0	0	0	0	0	3	9	28
1:45 PM	0	1	1	0	0	0	1	0	0	1	0	0	0	0	0	0	4	23
2:00 PM	0	1	0	0	0	0	1	0	0	0	0	0	0	0	0	2	4	21
2:15 PM	0	0	1	0	0	0	2	0	0	1	1	0	0	1	0	1	7	24
2:30 PM	0	0	0	0	0	0	0	0	0	1	0	0	0	0	0	0	1	16
2:45 PM	0	0	0	0	0	0	0	1	0	0	1	0	0	0	0	0	2	14
3:00 PM	0	0	0	0	0	0	2	0	0	0	1	0	0	0	0	0	3	13
3:15 PM	0	2	0	0	0	0	1	0	0	1	0	0	0	0	0	1	5	11
3:30 PM	0	0	2	0	0	0	0	0	0	0	0	0	0	0	0	2	4	14
3:45 PM	0	1	2	0	0	0	2	1	0	0	1	2	0	1	0	0	10	22
Count Total	0	12	31	0	0	0	31	6	0	13	9	8	0	5	0	26	141	0
Peak Hour	0	2	5	0	0	0	5	0	0	3	0	2	0	0	0	2	19	0

<b>Six-Hour Count Summaries - Bikes</b>																
Interval Start	Old Redwood Hwy			Old Redwood Hwy			US-101 NB Ramps			Lakewood Dr			15-min Total	Rolling One Hour		
	Eastbound			Westbound			Northbound			Southbound						
	LT	TH	RT	LT	TH	RT	LT	TH	RT	LT	TH	RT				
10:00 AM	0	1	0	0	1	1	0	0	0	0	0	0	3	0		
10:15 AM	0	1	0	0	1	1	0	0	0	0	0	0	3	0		
10:30 AM	0	0	0	0	1	1	0	0	0	0	0	1	3	0		
10:45 AM	0	0	0	0	0	0	0	0	0	0	0	0	0	9		
11:00 AM	0	1	0	0	0	0	0	0	0	0	0	0	1	7		
11:15 AM	0	1	0	0	0	0	0	0	0	0	0	2	3	7		
11:30 AM	0	0	0	0	0	1	0	0	0	0	0	1	2	6		
<b>11:45 AM</b>	<b>0</b>	<b>0</b>	<b>0</b>	<b>0</b>	<b>0</b>	<b>2</b>	<b>0</b>	<b>0</b>	<b>0</b>	<b>0</b>	<b>0</b>	<b>0</b>	<b>2</b>	<b>8</b>		
<b>12:00 PM</b>	<b>0</b>	<b>4</b>	<b>0</b>	<b>0</b>	<b>1</b>	<b>1</b>	<b>0</b>	<b>0</b>	<b>0</b>	<b>1</b>	<b>0</b>	<b>0</b>	<b>7</b>	<b>14</b>		
<b>12:15 PM</b>	<b>0</b>	<b>0</b>	<b>0</b>	<b>0</b>	<b>2</b>	<b>1</b>	<b>0</b>	<b>0</b>	<b>0</b>	<b>0</b>	<b>0</b>	<b>2</b>	<b>5</b>	<b>16</b>		
<b>12:30 PM</b>	<b>0</b>	<b>6</b>	<b>0</b>	<b>0</b>	<b>0</b>	<b>2</b>	<b>0</b>	<b>0</b>	<b>0</b>	<b>0</b>	<b>0</b>	<b>0</b>	<b>8</b>	<b>22</b>		
12:45 PM	0	1	0	0	0	1	0	0	0	0	0	1	3	23		
1:00 PM	0	1	0	0	1	0	0	0	0	0	0	0	2	18		
1:15 PM	0	1	0	0	3	1	0	0	0	0	0	0	5	18		
1:30 PM	0	2	0	0	2	0	0	0	0	0	0	0	4	14		
1:45 PM	0	3	0	0	2	0	0	0	0	0	0	0	5	16		
2:00 PM	0	0	0	0	2	0	0	0	0	0	0	0	2	16		
2:15 PM	0	0	0	0	3	0	0	0	0	0	0	0	3	14		
2:30 PM	0	2	0	0	0	0	0	0	0	0	0	0	2	12		
2:45 PM	1	3	0	0	0	0	0	0	0	0	0	1	5	12		
3:00 PM	0	1	0	0	0	0	0	0	0	2	0	0	3	13		
3:15 PM	0	2	0	0	1	0	0	0	0	0	0	0	3	13		
3:30 PM	0	0	0	0	2	0	0	0	0	0	0	1	3	14		
3:45 PM	0	2	0	0	0	0	0	0	0	0	0	1	3	12		
Count Total	1	32	0	0	22	12	0	0	0	5	0	8	80	0		
Peak Hour	0	10	0	0	3	6	0	0	0	1	0	2	22	0		

Note: U-Turn volumes for bikes are included in Left-Turn, if any.

## US-101 NB On-Ramp Old Redwood Hwy



Date: 07/30/2022  
 Count Period: 10:00 AM to 4:00 PM  
 Peak Hour: 11:45 AM to 12:45 PM

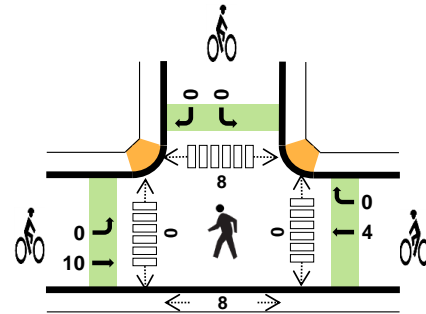
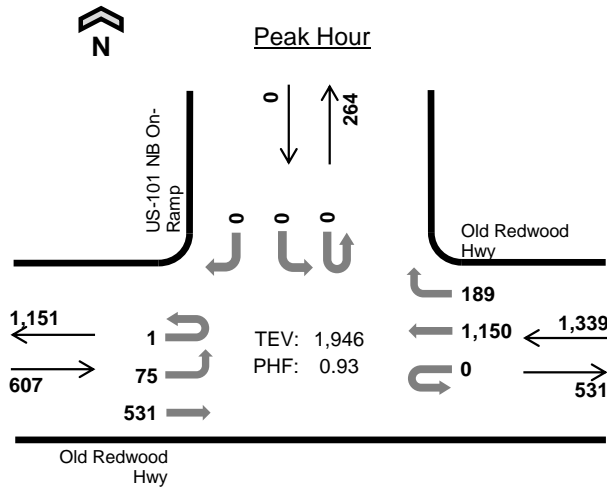

	HV %:	PHF
EB	1.3%	0.96
WB	0.6%	0.92
NB	-	-
SB	-	-
TOTAL	0.8%	0.93

### Six-Hour Count Summaries

Interval Start	Old Redwood Hwy				Old Redwood Hwy				N/A				US-101 NB On-Ramp				15-min Total	Rolling One Hour	
	Eastbound		Westbound		Northbound		Southbound		UT		LT		TH		RT				
	UT	LT	TH	RT	UT	LT	TH	RT	UT	LT	TH	RT	UT	LT	TH	RT			
11:45 AM	0	24	134	0	0	0	305	60	0	0	0	0	0	0	0	0	0	523	0
12:00 PM	0	19	139	0	0	0	294	44	0	0	0	0	0	0	0	0	0	496	0
12:15 PM	1	17	132	0	0	0	262	41	0	0	0	0	0	0	0	0	0	453	0
12:30 PM	0	15	126	0	0	0	289	44	0	0	0	0	0	0	0	0	0	474	1,946
Peak Hour	All	1	75	531	0	0	0	1,150	189	0	0	0	0	0	0	0	0	1,946	0
	HV	0	0	8	0	0	0	6	2	0	0	0	0	0	0	0	0	16	0
	HV%	0%	0%	2%	-	-	-	1%	1%	-	-	-	-	-	-	-	-	1%	0

Note: For all three-hour count summary, see next page.

Interval Start	Heavy Vehicle Totals					Bicycles					Pedestrians (Crossing Leg)				
	EB	WB	NB	SB	Total	EB	WB	NB	SB	Total	East	West	North	South	Total
11:45 AM	3	4	0	0	7	0	0	0	0	0	0	0	3	0	3
12:00 PM	1	1	0	0	2	4	1	0	0	5	0	0	1	2	3
12:15 PM	2	1	0	0	3	0	3	0	0	3	0	0	2	0	2
12:30 PM	2	2	0	0	4	6	0	0	0	6	0	0	2	6	8
Peak Hour	8	8	0	0	16	10	4	0	0	14	0	0	8	8	16

Six-Hour Count Summaries																		
Interval Start	Old Redwood Hwy				Old Redwood Hwy				N/A				US-101 NB On-Ramp				15-min Total	Rolling One Hour
	Eastbound				Westbound				Northbound				Southbound					
	UT	LT	TH	RT	UT	LT	TH	RT	UT	LT	TH	RT	UT	LT	TH	RT		
10:00 AM	0	10	107	0	0	0	233	30	0	0	0	0	0	0	0	0	380	0
10:15 AM	1	29	98	0	0	0	241	45	0	0	0	0	0	0	0	0	414	0
10:30 AM	0	17	95	0	0	0	260	46	0	0	0	0	0	0	0	0	418	0
10:45 AM	0	24	120	0	0	0	257	48	0	0	0	0	0	0	0	0	449	1,661
11:00 AM	0	18	130	0	1	0	263	53	0	0	0	0	0	0	0	0	465	1,746
11:15 AM	0	24	119	0	0	0	251	48	0	0	0	0	0	0	0	0	442	1,774
11:30 AM	0	22	123	0	0	0	279	36	0	0	0	0	0	0	0	0	460	1,816
<b>11:45 AM</b>	<b>0</b>	<b>24</b>	<b>134</b>	<b>0</b>	<b>0</b>	<b>0</b>	<b>305</b>	<b>60</b>	<b>0</b>	<b>0</b>	<b>0</b>	<b>0</b>	<b>0</b>	<b>0</b>	<b>0</b>	<b>0</b>	<b>523</b>	<b>1,890</b>
<b>12:00 PM</b>	<b>0</b>	<b>19</b>	<b>139</b>	<b>0</b>	<b>0</b>	<b>0</b>	<b>294</b>	<b>44</b>	<b>0</b>	<b>0</b>	<b>0</b>	<b>0</b>	<b>0</b>	<b>0</b>	<b>0</b>	<b>0</b>	<b>496</b>	<b>1,921</b>
<b>12:15 PM</b>	<b>1</b>	<b>17</b>	<b>132</b>	<b>0</b>	<b>0</b>	<b>0</b>	<b>262</b>	<b>41</b>	<b>0</b>	<b>0</b>	<b>0</b>	<b>0</b>	<b>0</b>	<b>0</b>	<b>0</b>	<b>0</b>	<b>453</b>	<b>1,932</b>
<b>12:30 PM</b>	<b>0</b>	<b>15</b>	<b>126</b>	<b>0</b>	<b>0</b>	<b>0</b>	<b>289</b>	<b>44</b>	<b>0</b>	<b>0</b>	<b>0</b>	<b>0</b>	<b>0</b>	<b>0</b>	<b>0</b>	<b>0</b>	<b>474</b>	<b>1,946</b>
12:45 PM	0	19	116	0	0	0	270	50	0	0	0	0	0	0	0	0	455	1,878
1:00 PM	0	8	105	0	0	0	274	31	0	0	0	0	0	0	0	0	418	1,800
1:15 PM	0	24	113	0	0	0	285	49	0	0	0	0	0	0	0	0	471	1,818
1:30 PM	0	26	117	0	0	0	272	36	0	0	0	0	0	0	0	0	451	1,795
1:45 PM	0	31	154	0	0	0	263	34	0	0	0	0	0	0	0	0	482	1,822
2:00 PM	0	20	99	0	0	0	293	47	0	0	0	0	0	0	0	0	459	1,863
2:15 PM	1	21	127	0	0	0	257	47	0	0	0	0	0	0	0	0	453	1,845
2:30 PM	1	26	116	0	0	0	242	47	0	0	0	0	0	0	0	0	432	1,826
2:45 PM	0	23	119	0	0	0	229	50	0	0	0	0	0	0	0	0	421	1,765
3:00 PM	1	20	111	0	0	0	262	45	0	0	0	0	0	0	0	0	439	1,745
3:15 PM	1	20	118	0	0	0	248	35	0	0	0	0	0	0	0	0	422	1,714
3:30 PM	0	18	96	0	0	0	256	61	0	0	0	0	0	0	0	0	431	1,713
3:45 PM	0	16	116	0	0	0	253	37	0	0	0	0	0	0	0	0	422	1,714
Count Total	6	491	2,830	0	1	0	6,338	1,064	0	0	0	0	0	0	0	0	10,730	0
Peak Hour	All	1	75	531	0	0	0	1,150	189	0	0	0	0	0	0	0	1,946	0
	HV	0	0	8	0	0	0	6	2	0	0	0	0	0	0	0	16	0
	HV%	0%	0%	2%	-	-	-	1%	1%	-	-	-	-	-	-	-	1%	0

Note: Six-hour count summary volumes include heavy vehicles but exclude bicycles in overall count.

Interval Start	Heavy Vehicle Totals					Bicycles					Pedestrians (Crossing Leg)				
	EB	WB	NB	SB	Total	EB	WB	NB	SB	Total	East	West	North	South	Total
10:00 AM	2	2	0	0	4	1	1	0	0	2	0	0	0	2	2
10:15 AM	2	3	0	0	5	1	1	0	0	2	0	0	0	1	1
10:30 AM	2	5	0	0	7	0	1	0	0	1	0	0	6	2	8
10:45 AM	3	4	0	0	7	0	0	0	0	0	0	0	2	0	2
11:00 AM	3	4	0	0	7	0	0	0	0	0	0	0	0	0	0
11:15 AM	4	3	0	0	7	1	0	0	0	1	0	0	6	0	6
11:30 AM	0	4	0	0	4	0	0	0	0	0	0	0	0	2	2
<b>11:45 AM</b>	<b>3</b>	<b>4</b>	<b>0</b>	<b>0</b>	<b>7</b>	<b>0</b>	<b>0</b>	<b>0</b>	<b>0</b>	<b>0</b>	<b>0</b>	<b>0</b>	<b>3</b>	<b>0</b>	<b>3</b>
<b>12:00 PM</b>	<b>1</b>	<b>1</b>	<b>0</b>	<b>0</b>	<b>2</b>	<b>4</b>	<b>1</b>	<b>0</b>	<b>0</b>	<b>5</b>	<b>0</b>	<b>0</b>	<b>1</b>	<b>2</b>	<b>3</b>
<b>12:15 PM</b>	<b>2</b>	<b>1</b>	<b>0</b>	<b>0</b>	<b>3</b>	<b>0</b>	<b>3</b>	<b>0</b>	<b>0</b>	<b>3</b>	<b>0</b>	<b>0</b>	<b>2</b>	<b>0</b>	<b>2</b>
<b>12:30 PM</b>	<b>2</b>	<b>2</b>	<b>0</b>	<b>0</b>	<b>4</b>	<b>6</b>	<b>0</b>	<b>0</b>	<b>0</b>	<b>6</b>	<b>0</b>	<b>0</b>	<b>2</b>	<b>6</b>	<b>8</b>
12:45 PM	1	3	0	0	4	0	0	0	0	0	0	0	7	1	8
1:00 PM	1	4	0	0	5	1	1	0	0	2	0	0	6	1	7
1:15 PM	1	2	0	0	3	1	3	0	0	4	0	0	5	0	5
1:30 PM	5	6	0	0	11	2	1	0	0	3	0	0	3	1	4
1:45 PM	1	2	0	0	3	3	1	0	0	4	0	0	10	3	13
2:00 PM	2	3	0	0	5	0	4	0	0	4	0	0	1	0	1
2:15 PM	0	4	0	0	4	1	2	0	0	3	0	0	0	0	0
2:30 PM	1	1	0	0	2	2	0	0	0	2	0	0	4	0	4
2:45 PM	0	0	0	0	0	3	0	0	0	3	0	0	2	0	2
3:00 PM	0	1	0	0	1	1	0	0	0	1	0	0	8	0	8
3:15 PM	2	3	0	0	5	2	1	0	0	3	0	0	1	0	1
3:30 PM	1	3	0	0	4	0	4	0	0	4	0	0	5	0	5
3:45 PM	2	3	0	0	5	2	1	0	0	3	0	0	0	0	0
Count Total	41	68	0	0	109	31	25	0	0	56	0	0	74	21	95
Peak Hr	8	8	0	0	16	10	4	0	0	14	0	0	8	8	16

<b>Six-Hour Count Summaries - Heavy Vehicles</b>																		
Interval Start	Old Redwood Hwy				Old Redwood Hwy				N/A				US-101 NB On-Ramp				15-min Total	Rolling One Hour
	Eastbound				Westbound				Northbound				Southbound					
	UT	LT	TH	RT	UT	LT	TH	RT	UT	LT	TH	RT	UT	LT	TH	RT		
10:00 AM	0	1	1	0	0	0	1	1	0	0	0	0	0	0	0	0	4	0
10:15 AM	0	0	2	0	0	0	2	1	0	0	0	0	0	0	0	0	5	0
10:30 AM	0	1	1	0	0	0	3	2	0	0	0	0	0	0	0	0	7	0
10:45 AM	0	1	2	0	0	0	3	1	0	0	0	0	0	0	0	0	7	23
11:00 AM	0	0	3	0	0	0	4	0	0	0	0	0	0	0	0	0	7	26
11:15 AM	0	1	3	0	0	0	2	1	0	0	0	0	0	0	0	0	7	28
11:30 AM	0	0	0	0	0	0	4	0	0	0	0	0	0	0	0	0	4	25
<b>11:45 AM</b>	<b>0</b>	<b>0</b>	<b>3</b>	<b>0</b>	<b>0</b>	<b>0</b>	<b>2</b>	<b>2</b>	<b>0</b>	<b>0</b>	<b>0</b>	<b>0</b>	<b>0</b>	<b>0</b>	<b>0</b>	<b>0</b>	<b>7</b>	<b>25</b>
12:00 PM	0	0	1	0	0	0	1	0	0	0	0	0	0	0	0	0	2	20
12:15 PM	0	0	2	0	0	0	1	0	0	0	0	0	0	0	0	0	3	16
12:30 PM	0	0	2	0	0	0	2	0	0	0	0	0	0	0	0	0	4	16
12:45 PM	0	1	0	0	0	0	3	0	0	0	0	0	0	0	0	0	4	13
1:00 PM	0	0	1	0	0	0	4	0	0	0	0	0	0	0	0	0	5	16
1:15 PM	0	0	1	0	0	0	2	0	0	0	0	0	0	0	0	0	3	16
1:30 PM	0	1	4	0	0	0	6	0	0	0	0	0	0	0	0	0	11	23
1:45 PM	0	0	1	0	0	0	2	0	0	0	0	0	0	0	0	0	3	22
2:00 PM	0	0	2	0	0	0	3	0	0	0	0	0	0	0	0	0	5	22
2:15 PM	0	0	0	0	0	0	3	1	0	0	0	0	0	0	0	0	4	23
2:30 PM	0	1	0	0	0	0	1	0	0	0	0	0	0	0	0	0	2	14
2:45 PM	0	0	0	0	0	0	0	0	0	0	0	0	0	0	0	0	0	11
3:00 PM	0	0	0	0	0	0	1	0	0	0	0	0	0	0	0	0	1	7
3:15 PM	0	0	2	0	0	0	2	1	0	0	0	0	0	0	0	0	5	8
3:30 PM	0	0	1	0	0	0	1	2	0	0	0	0	0	0	0	0	4	10
3:45 PM	0	0	2	0	0	0	2	1	0	0	0	0	0	0	0	0	5	15
Count Total	0	7	34	0	0	0	55	13	0	0	0	0	0	0	0	0	109	0
Peak Hour	0	0	8	0	0	0	6	2	0	0	0	0	0	0	0	0	16	0

<b>Six-Hour Count Summaries - Bikes</b>																
Interval Start	Old Redwood Hwy			Old Redwood Hwy			N/A			US-101 NB On-Ramp			15-min Total	Rolling One Hour		
	Eastbound			Westbound			Northbound			Southbound						
	LT	TH	RT	LT	TH	RT	LT	TH	RT	LT	TH	RT				
10:00 AM	0	1	0	0	1	0	0	0	0	0	0	0	2	0		
10:15 AM	0	1	0	0	1	0	0	0	0	0	0	0	2	0		
10:30 AM	0	0	0	0	1	0	0	0	0	0	0	0	1	0		
10:45 AM	0	0	0	0	0	0	0	0	0	0	0	0	0	5		
11:00 AM	0	0	0	0	0	0	0	0	0	0	0	0	0	3		
11:15 AM	0	1	0	0	0	0	0	0	0	0	0	0	1	2		
11:30 AM	0	0	0	0	0	0	0	0	0	0	0	0	0	1		
<b>11:45 AM</b>	<b>0</b>	<b>0</b>	<b>0</b>	<b>0</b>	<b>0</b>	<b>0</b>	<b>0</b>	<b>0</b>	<b>0</b>	<b>0</b>	<b>0</b>	<b>0</b>	<b>0</b>	<b>1</b>		
12:00 PM	0	4	0	0	1	0	0	0	0	0	0	0	5	6		
12:15 PM	0	0	0	0	3	0	0	0	0	0	0	0	3	8		
12:30 PM	0	6	0	0	0	0	0	0	0	0	0	0	6	14		
12:45 PM	0	0	0	0	0	0	0	0	0	0	0	0	0	14		
1:00 PM	0	1	0	0	1	0	0	0	0	0	0	0	2	11		
1:15 PM	1	0	0	0	2	1	0	0	0	0	0	0	4	12		
1:30 PM	0	2	0	0	1	0	0	0	0	0	0	0	3	9		
1:45 PM	0	3	0	0	1	0	0	0	0	0	0	0	4	13		
2:00 PM	0	0	0	0	4	0	0	0	0	0	0	0	4	15		
2:15 PM	0	1	0	0	2	0	0	0	0	0	0	0	3	14		
2:30 PM	0	2	0	0	0	0	0	0	0	0	0	0	2	13		
2:45 PM	0	3	0	0	0	0	0	0	0	0	0	0	3	12		
3:00 PM	0	1	0	0	0	0	0	0	0	0	0	0	1	9		
3:15 PM	0	2	0	0	1	0	0	0	0	0	0	0	3	9		
3:30 PM	0	0	0	0	4	0	0	0	0	0	0	0	4	11		
3:45 PM	0	2	0	0	1	0	0	0	0	0	0	0	3	11		
Count Total	1	30	0	0	24	1	0	0	0	0	0	0	56	0		
Peak Hour	0	10	0	0	4	0	0	0	0	0	0	0	14	0		

Note: U-Turn volumes for bikes are included in Left-Turn, if any.

# US-101 SB Ramps Old Redwood Hwy



Date: 07/30/2022  
 Count Period: 10:00 AM to 4:00 PM  
 Peak Hour: 11:30 AM to 12:30 PM

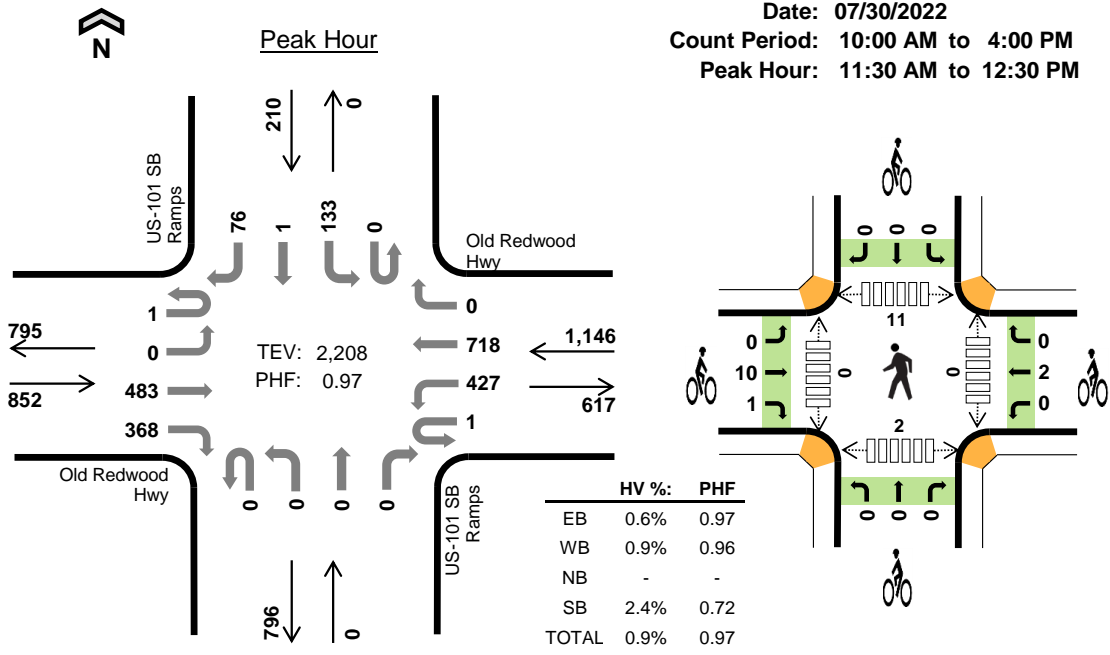

### Six-Hour Count Summaries

Interval Start	Old Redwood Hwy				Old Redwood Hwy				US-101 SB Ramps				US-101 SB Ramps				15-min Total	Rolling One Hour
	Eastbound		Westbound		Northbound		Southbound		UT	LT	TH	RT	UT	LT	TH	RT		
11:30 AM	0	0	116	96	0	117	166	0	0	0	0	0	0	22	0	17	534	0
11:45 AM	0	0	132	88	0	103	193	0	0	0	0	0	0	38	0	14	568	0
12:00 PM	1	0	122	86	0	123	174	0	0	0	0	0	0	33	0	13	552	0
12:15 PM	0	0	113	98	1	84	185	0	0	0	0	0	0	40	1	32	554	2,208
Peak Hour	All	1	0	483	368	1	427	718	0	0	0	0	0	133	1	76	2,208	0
	HV	0	0	3	2	0	3	7	0	0	0	0	0	3	0	2	20	0
	HV%	0%	-	1%	1%	0%	1%	1%	-	-	-	-	-	2%	0%	3%	1%	0

Note: For all three-hour count summary, see next page.

Interval Start	Heavy Vehicle Totals					Bicycles					Pedestrians (Crossing Leg)				
	EB	WB	NB	SB	Total	EB	WB	NB	SB	Total	East	West	North	South	Total
11:30 AM	1	5	0	0	6	0	0	0	0	0	0	0	0	1	1
11:45 AM	3	2	0	3	8	0	0	0	0	0	0	0	1	0	1
12:00 PM	0	1	0	1	2	4	0	0	0	4	0	0	5	1	6
12:15 PM	1	2	0	1	4	7	2	0	0	9	0	0	5	0	5
Peak Hour	5	10	0	5	20	11	2	0	0	13	0	0	11	2	13



Six-Hour Count Summaries																		
Interval Start	Old Redwood Hwy				Old Redwood Hwy				US-101 SB Ramps				US-101 SB Ramps				15-min Total	Rolling One Hour
	Eastbound		Westbound		Northbound		Southbound		UT	LT	TH	RT	UT	LT	TH	RT		
10:00 AM	0	0	100	79	0	83	152	0	0	0	0	0	0	20	0	25	459	0
10:15 AM	0	0	105	95	0	105	135	0	0	0	0	0	0	23	0	24	487	0
10:30 AM	0	0	90	79	0	91	172	0	0	0	0	0	0	20	0	20	472	0
10:45 AM	0	0	128	78	0	106	140	0	0	0	0	0	0	20	0	14	486	1,904
11:00 AM	0	0	121	80	1	85	183	0	0	0	0	0	0	18	0	18	506	1,951
11:15 AM	0	0	123	100	0	98	148	0	0	0	0	0	0	30	1	3	503	1,967
11:30 AM	0	0	116	96	0	117	166	0	0	0	0	0	0	22	0	17	534	2,029
11:45 AM	0	0	132	88	0	103	193	0	0	0	0	0	0	38	0	14	568	2,111
12:00 PM	1	0	122	86	0	123	174	0	0	0	0	0	0	33	0	13	552	2,157
12:15 PM	0	0	113	98	1	84	185	0	0	0	0	0	0	40	1	32	554	2,208
12:30 PM	0	0	97	74	1	107	188	0	0	0	0	0	0	33	0	30	530	2,204
12:45 PM	0	0	103	90	2	82	177	0	0	0	0	0	0	31	0	32	517	2,153
1:00 PM	0	0	107	101	0	103	169	0	0	0	0	0	0	20	1	19	520	2,121
1:15 PM	0	0	105	95	1	113	176	0	0	0	0	0	0	23	1	22	536	2,103
1:30 PM	0	0	125	80	1	91	170	0	0	0	0	0	0	37	1	20	525	2,098
1:45 PM	0	0	136	83	0	90	178	0	0	0	0	0	0	33	0	25	545	2,126
2:00 PM	0	0	94	76	0	95	200	0	0	0	0	0	0	23	0	21	509	2,115
2:15 PM	0	0	116	96	0	77	178	0	0	0	0	0	0	29	0	18	514	2,093
2:30 PM	0	0	111	94	0	97	144	0	0	0	0	0	0	31	2	25	504	2,072
2:45 PM	0	0	112	92	1	77	154	0	0	0	0	0	0	27	1	25	489	2,016
3:00 PM	0	0	106	88	0	99	161	0	0	0	0	0	0	37	0	16	507	2,014
3:15 PM	0	0	97	71	1	92	154	0	0	0	0	0	0	38	0	20	473	1,973
3:30 PM	0	0	95	70	0	88	171	0	0	0	0	0	0	14	0	20	458	1,927
3:45 PM	0	0	102	75	0	96	160	0	0	0	0	0	0	23	0	26	482	1,920
Count Total	1	0	2,656	2,064	9	2,302	4,028	0	0	0	0	0	0	663	8	499	12,230	0
Peak Hour	All	1	0	483	368	1	427	718	0	0	0	0	0	133	1	76	2,208	0
	HV	0	0	3	2	0	3	7	0	0	0	0	0	3	0	2	20	0
	HV%	0%	-	1%	1%	0%	1%	1%	-	-	-	-	-	2%	0%	3%	1%	0

Note: Six-hour count summary volumes include heavy vehicles but exclude bicycles in overall count.

Interval Start	Heavy Vehicle Totals					Bicycles					Pedestrians (Crossing Leg)				
	EB	WB	NB	SB	Total	EB	WB	NB	SB	Total	East	West	North	South	Total
10:00 AM	4	1	0	1	6	1	1	0	0	2	0	0	2	0	2
10:15 AM	5	3	0	1	9	1	1	0	0	2	0	0	2	2	4
10:30 AM	4	3	0	1	8	0	1	0	0	1	0	0	7	1	8
10:45 AM	3	2	0	0	5	0	0	0	0	0	0	0	3	1	4
11:00 AM	4	3	0	3	10	1	2	0	0	3	0	0	0	0	0
11:15 AM	4	2	0	1	7	1	0	0	0	1	0	0	6	0	6
11:30 AM	1	5	0	0	6	0	0	0	0	0	0	0	0	1	1
11:45 AM	3	2	0	3	8	0	0	0	0	0	0	0	1	0	1
12:00 PM	0	1	0	1	2	4	0	0	0	4	0	0	5	1	6
12:15 PM	1	2	0	1	4	7	2	0	0	9	0	0	5	0	5
12:30 PM	2	2	0	0	4	0	0	0	0	0	0	0	3	0	3
12:45 PM	2	3	0	1	6	1	1	0	0	2	0	0	4	0	4
1:00 PM	1	1	0	1	3	1	1	0	0	2	0	0	3	1	4
1:15 PM	0	2	0	2	4	1	0	0	0	1	0	0	8	1	9
1:30 PM	3	6	0	2	11	2	1	0	0	3	0	0	4	0	4
1:45 PM	1	2	0	0	3	3	2	0	0	5	0	0	10	0	10
2:00 PM	2	3	0	0	5	0	3	0	0	3	0	0	1	0	1
2:15 PM	0	3	0	0	3	0	3	0	0	3	0	0	0	0	0
2:30 PM	2	1	0	0	3	2	3	0	0	5	0	0	3	0	3
2:45 PM	0	0	0	0	0	3	1	0	0	4	0	0	1	2	3
3:00 PM	1	3	0	0	4	1	0	0	0	1	0	0	6	1	7
3:15 PM	2	2	0	0	4	2	1	0	0	3	0	0	6	0	6
3:30 PM	0	1	0	0	1	0	4	0	0	4	0	0	4	0	4
3:45 PM	1	2	0	1	4	1	1	0	0	2	0	0	2	0	2
Count Total	46	55	0	19	120	32	28	0	0	60	0	0	86	11	97
Peak Hour	5	10	0	5	20	11	2	0	0	13	0	0	11	2	13

<b>Six-Hour Count Summaries - Heavy Vehicles</b>																			
Interval Start	Old Redwood Hwy				Old Redwood Hwy				US-101 SB Ramps				US-101 SB Ramps				15-min Total	Rolling One Hour	
	Eastbound				Westbound				Northbound				Southbound						
	UT	LT	TH	RT	UT	LT	TH	RT	UT	LT	TH	RT	UT	LT	TH	RT			
10:00 AM	0	0	2	2	0	0	1	0	0	0	0	0	0	0	0	1	6	0	
10:15 AM	0	0	2	3	0	0	3	0	0	0	0	0	0	0	0	1	9	0	
10:30 AM	0	0	1	3	0	1	2	0	0	0	0	0	0	0	1	0	8	0	
10:45 AM	0	0	3	0	0	1	1	0	0	0	0	0	0	0	0	0	5	28	
11:00 AM	0	0	2	2	0	3	0	0	0	0	0	0	0	0	2	1	10	32	
11:15 AM	0	0	4	0	0	0	2	0	0	0	0	0	0	0	0	1	7	30	
11:30 AM	0	0	0	1	0	3	2	0	0	0	0	0	0	0	0	0	6	28	
11:45 AM	0	0	2	1	0	0	2	0	0	0	0	0	0	0	2	1	8	31	
12:00 PM	0	0	0	0	0	0	1	0	0	0	0	0	0	0	1	0	2	23	
12:15 PM	0	0	1	0	0	0	2	0	0	0	0	0	0	0	0	1	4	20	
12:30 PM	0	0	2	0	0	2	0	0	0	0	0	0	0	0	0	0	4	18	
12:45 PM	0	0	1	1	0	0	3	0	0	0	0	0	0	0	0	1	6	16	
1:00 PM	0	0	1	0	0	0	1	0	0	0	0	0	0	0	0	1	3	17	
1:15 PM	0	0	0	0	0	1	1	0	0	0	0	0	0	0	2	0	4	17	
1:30 PM	0	0	2	1	0	3	3	0	0	0	0	0	0	0	2	0	11	24	
1:45 PM	0	0	1	0	0	1	1	0	0	0	0	0	0	0	0	0	3	21	
2:00 PM	0	0	2	0	0	1	2	0	0	0	0	0	0	0	0	0	5	23	
2:15 PM	0	0	0	0	0	1	2	0	0	0	0	0	0	0	0	0	3	22	
2:30 PM	0	0	1	1	0	0	1	0	0	0	0	0	0	0	0	0	3	14	
2:45 PM	0	0	0	0	0	0	0	0	0	0	0	0	0	0	0	0	0	11	
3:00 PM	0	0	1	0	0	0	3	0	0	0	0	0	0	0	0	0	4	10	
3:15 PM	0	0	2	0	0	1	1	0	0	0	0	0	0	0	0	0	4	11	
3:30 PM	0	0	0	0	0	0	1	0	0	0	0	0	0	0	0	0	1	9	
3:45 PM	0	0	1	0	0	2	0	0	0	0	0	0	0	0	1	0	4	13	
Count Total	0	0	31	15	0	20	35	0	0	0	0	0	0	0	11	0	8	120	0
Peak Hour	0	0	3	2	0	3	7	0	0	0	0	0	0	0	3	0	2	20	0

<b>Six-Hour Count Summaries - Bikes</b>																
Interval Start	Old Redwood Hwy			Old Redwood Hwy			US-101 SB Ramps			US-101 SB Ramps			15-min Total	Rolling One Hour		
	Eastbound			Westbound			Northbound			Southbound						
	LT	TH	RT	LT	TH	RT	LT	TH	RT	LT	TH	RT				
10:00 AM	0	1	0	0	1	0	0	0	0	0	0	0	0	2	0	
10:15 AM	0	1	0	0	1	0	0	0	0	0	0	0	0	2	0	
10:30 AM	0	0	0	0	1	0	0	0	0	0	0	0	0	1	0	
10:45 AM	0	0	0	0	0	0	0	0	0	0	0	0	0	0	5	
11:00 AM	0	1	0	0	2	0	0	0	0	0	0	0	0	3	6	
11:15 AM	0	1	0	0	0	0	0	0	0	0	0	0	0	1	5	
11:30 AM	0	0	0	0	0	0	0	0	0	0	0	0	0	0	4	
11:45 AM	0	0	0	0	0	0	0	0	0	0	0	0	0	0	4	
12:00 PM	0	4	0	0	0	0	0	0	0	0	0	0	0	4	5	
12:15 PM	0	6	1	0	2	0	0	0	0	0	0	0	0	9	13	
12:30 PM	0	0	0	0	0	0	0	0	0	0	0	0	0	0	13	
12:45 PM	0	1	0	0	1	0	0	0	0	0	0	0	0	2	15	
1:00 PM	0	1	0	0	1	0	0	0	0	0	0	0	0	2	13	
1:15 PM	0	1	0	0	0	0	0	0	0	0	0	0	0	1	5	
1:30 PM	0	2	0	0	1	0	0	0	0	0	0	0	0	3	8	
1:45 PM	0	3	0	0	2	0	0	0	0	0	0	0	0	5	11	
2:00 PM	0	0	0	0	3	0	0	0	0	0	0	0	0	3	12	
2:15 PM	0	0	0	0	3	0	0	0	0	0	0	0	0	3	14	
2:30 PM	0	2	0	0	3	0	0	0	0	0	0	0	0	5	16	
2:45 PM	0	3	0	0	1	0	0	0	0	0	0	0	0	4	15	
3:00 PM	0	1	0	0	0	0	0	0	0	0	0	0	0	1	13	
3:15 PM	0	2	0	0	1	0	0	0	0	0	0	0	0	3	13	
3:30 PM	0	0	0	0	4	0	0	0	0	0	0	0	0	4	12	
3:45 PM	0	1	0	0	1	0	0	0	0	0	0	0	0	2	10	
Count Total	0	31	1	0	28	0	0	0	0	0	0	0	0	60	0	
Peak Hour	0	10	1	0	2	0	0	0	0	0	0	0	0	13	0	

Note: U-Turn volumes for bikes are included in Left-Turn, if any.

## Vehicle Classification Report Summary

**Location:** Old Redwood Highway, BTW Shiloh Rd & Kendall Way  
**Count Direction:** Northbound / Southbound  
**Date Range:** 7/28/2022 to 7/28/2022  
**Site Code:** 01

	FHWA Vehicle Classification													Total Volume
	1	2	3	4	5	6	7	8	9	10	11	12	13	
<b>Study Total</b>														
<b>Northbound</b>	45	3,452	1,015	36	637	36	0	9	2	2	0	0	0	5,234
<b>Percent</b>	0.9%	66.0%	19.4%	0.7%	12.2%	0.7%	0.0%	0.2%	0.0%	0.0%	0.0%	0.0%	0.0%	100%
<b>Southbound</b>	77	3,735	995	23	578	67	0	0	1	0	0	0	0	5,476
<b>Percent</b>	1.4%	68.2%	18.2%	0.4%	10.6%	1.2%	0.0%	0.0%	0.0%	0.0%	0.0%	0.0%	0.0%	100%
<b>Total</b>	122	7,187	2,010	59	1,215	103	0	9	3	2	0	0	0	10,710
<b>Percent</b>	1.1%	67.1%	18.8%	0.6%	11.3%	1.0%	0.0%	0.1%	0.0%	0.0%	0.0%	0.0%	0.0%	100%

FHWA Vehicle Classification	
Class 1 - Motorcycles	Class 8 - Four or Fewer Axle Single-Trailer Trucks
Class 2 - Passenger Cars	Class 9 - Five-Axle Single-Trailer Trucks
Class 3 - Other Two-Axle, Four-Tire Single Unit Vehicles	Class 10 - Six or More Axle Single-Trailer Trucks
Class 4 - Buses	Class 11 - Five or fewer Axle Multi-Trailer Trucks
Class 5 - Two-Axle, Six-Tire, Single-Unit Trucks	Class 12 - Six-Axle Multi-Trailer Trucks
Class 6 - Three-Axle Single-Unit Trucks	Class 13 - Seven or More Axle Multi-Trailer Trucks
Class 7 - Four or More Axle Single-Unit Trucks	

**Location:** Old Redwood Highway, BTW Shiloh Rd & Kendall Way  
**Date Range:** 7/28/2022 to 7/28/2022  
**Site Code:** 01

**Thursday, July 28, 2022**  
**Northbound**

Time	FHWA Vehicle Classification													Total Volume
	1	2	3	4	5	6	7	8	9	10	11	12	13	
12:00 AM	0	17	3	0	2	0	0	0	0	0	0	0	0	22
1:00 AM	0	20	9	0	2	0	0	0	0	0	0	0	0	31
2:00 AM	0	2	3	0	1	0	0	0	0	0	0	0	0	6
3:00 AM	0	4	4	1	2	0	0	0	0	0	0	0	0	11
4:00 AM	1	24	11	2	7	2	0	0	0	0	0	0	0	47
5:00 AM	0	27	3	7	5	6	0	1	0	0	0	0	0	49
6:00 AM	1	34	20	5	15	9	0	1	0	0	0	0	0	85
7:00 AM	2	110	38	9	34	1	0	2	1	0	0	0	0	197
8:00 AM	2	126	48	6	34	2	0	2	0	0	0	0	0	220
9:00 AM	2	172	60	5	24	9	0	2	1	0	0	0	0	275
10:00 AM	4	189	56	1	37	2	0	0	0	0	0	0	0	289
11:00 AM	3	199	60	0	56	0	0	0	0	0	0	0	0	318
12:00 PM	3	211	67	0	42	0	0	1	0	0	0	0	0	324
1:00 PM	2	208	56	0	52	1	0	0	0	1	0	0	0	320
2:00 PM	4	251	79	0	34	2	0	0	0	0	0	0	0	370
3:00 PM	1	333	81	0	44	0	0	0	0	0	0	0	0	459
4:00 PM	3	381	98	0	76	1	0	0	0	0	0	0	0	559
5:00 PM	4	358	105	0	58	1	0	0	0	0	0	0	0	526
6:00 PM	4	206	65	0	38	0	0	0	0	1	0	0	0	314
7:00 PM	2	178	53	0	21	0	0	0	0	0	0	0	0	254
8:00 PM	3	165	43	0	24	0	0	0	0	0	0	0	0	235
9:00 PM	1	124	32	0	18	0	0	0	0	0	0	0	0	175
10:00 PM	1	68	15	0	7	0	0	0	0	0	0	0	0	91
11:00 PM	2	45	6	0	4	0	0	0	0	0	0	0	0	57
<b>Total</b>	<b>45</b>	<b>3,452</b>	<b>1,015</b>	<b>36</b>	<b>637</b>	<b>36</b>	<b>0</b>	<b>9</b>	<b>2</b>	<b>2</b>	<b>0</b>	<b>0</b>	<b>0</b>	<b>5,234</b>
<b>Percent</b>	<b>0.9%</b>	<b>66.0%</b>	<b>19.4%</b>	<b>0.7%</b>	<b>12.2%</b>	<b>0.7%</b>	<b>0.0%</b>	<b>0.2%</b>	<b>0.0%</b>	<b>0.0%</b>	<b>0.0%</b>	<b>0.0%</b>	<b>0.0%</b>	

**Location:** Old Redwood Highway, BTW Shiloh Rd & Kendall Way  
**Date Range:** 7/28/2022 to 7/28/2022  
**Site Code:** 01

**Thursday, July 28, 2022**  
**Southbound**

Time	FHWA Vehicle Classification													Total Volume
	1	2	3	4	5	6	7	8	9	10	11	12	13	
12:00 AM	0	10	1	0	1	0	0	0	0	0	0	0	0	12
1:00 AM	0	7	5	0	0	0	0	0	0	0	0	0	0	12
2:00 AM	0	6	2	0	0	0	0	0	0	0	0	0	0	8
3:00 AM	0	7	2	0	6	0	0	0	0	0	0	0	0	15
4:00 AM	0	30	6	0	6	0	0	0	0	0	0	0	0	42
5:00 AM	1	74	31	2	28	14	0	0	0	0	0	0	0	150
6:00 AM	3	136	44	8	40	6	0	0	0	0	0	0	0	237
7:00 AM	6	242	64	4	47	12	0	0	0	0	0	0	0	375
8:00 AM	6	240	74	3	43	10	0	0	0	0	0	0	0	376
9:00 AM	5	226	69	4	19	10	0	0	0	0	0	0	0	333
10:00 AM	5	235	74	1	31	6	0	0	0	0	0	0	0	352
11:00 AM	5	221	69	0	34	1	0	0	0	0	0	0	0	330
12:00 PM	5	256	61	0	37	1	0	0	0	0	0	0	0	360
1:00 PM	9	246	58	0	51	1	0	0	0	0	0	0	0	365
2:00 PM	4	270	68	1	48	2	0	0	0	0	0	0	0	393
3:00 PM	3	269	71	0	36	0	0	0	0	0	0	0	0	379
4:00 PM	4	263	73	0	44	2	0	0	0	0	0	0	0	386
5:00 PM	10	281	75	0	39	0	0	0	0	0	0	0	0	405
6:00 PM	7	230	44	0	20	0	0	0	0	0	0	0	0	301
7:00 PM	2	161	34	0	21	1	0	0	1	0	0	0	0	220
8:00 PM	2	139	31	0	13	0	0	0	0	0	0	0	0	185
9:00 PM	0	97	22	0	6	1	0	0	0	0	0	0	0	126
10:00 PM	0	65	11	0	5	0	0	0	0	0	0	0	0	81
11:00 PM	0	24	6	0	3	0	0	0	0	0	0	0	0	33
<b>Total</b>	<b>77</b>	<b>3,735</b>	<b>995</b>	<b>23</b>	<b>578</b>	<b>67</b>	<b>0</b>	<b>0</b>	<b>1</b>	<b>0</b>	<b>0</b>	<b>0</b>	<b>0</b>	<b>5,476</b>
<b>Percent</b>	<b>1.4%</b>	<b>68.2%</b>	<b>18.2%</b>	<b>0.4%</b>	<b>10.6%</b>	<b>1.2%</b>	<b>0.0%</b>	<b>0.0%</b>	<b>0.0%</b>	<b>0.0%</b>	<b>0.0%</b>	<b>0.0%</b>	<b>0.0%</b>	

**Location:** Old Redwood Highway, BTW Shiloh Rd & Kendall Way  
**Date Range:** 7/28/2022 to 7/28/2022  
**Site Code:** 01

**Total Study Average  
Northbound**

Time	FHWA Vehicle Classification													Total Volume
	1	2	3	4	5	6	7	8	9	10	11	12	13	
12:00 AM	0	17	3	0	2	0	0	0	0	0	0	0	0	22
1:00 AM	0	20	9	0	2	0	0	0	0	0	0	0	0	31
2:00 AM	0	2	3	0	1	0	0	0	0	0	0	0	0	6
3:00 AM	0	4	4	1	2	0	0	0	0	0	0	0	0	11
4:00 AM	1	24	11	2	7	2	0	0	0	0	0	0	0	47
5:00 AM	0	27	3	7	5	6	0	1	0	0	0	0	0	49
6:00 AM	1	34	20	5	15	9	0	1	0	0	0	0	0	85
7:00 AM	2	110	38	9	34	1	0	2	1	0	0	0	0	197
8:00 AM	2	126	48	6	34	2	0	2	0	0	0	0	0	220
9:00 AM	2	172	60	5	24	9	0	2	1	0	0	0	0	275
10:00 AM	4	189	56	1	37	2	0	0	0	0	0	0	0	289
11:00 AM	3	199	60	0	56	0	0	0	0	0	0	0	0	318
12:00 PM	3	211	67	0	42	0	0	1	0	0	0	0	0	324
1:00 PM	2	208	56	0	52	1	0	0	0	1	0	0	0	320
2:00 PM	4	251	79	0	34	2	0	0	0	0	0	0	0	370
3:00 PM	1	333	81	0	44	0	0	0	0	0	0	0	0	459
4:00 PM	3	381	98	0	76	1	0	0	0	0	0	0	0	559
5:00 PM	4	358	105	0	58	1	0	0	0	0	0	0	0	526
6:00 PM	4	206	65	0	38	0	0	0	0	1	0	0	0	314
7:00 PM	2	178	53	0	21	0	0	0	0	0	0	0	0	254
8:00 PM	3	165	43	0	24	0	0	0	0	0	0	0	0	235
9:00 PM	1	124	32	0	18	0	0	0	0	0	0	0	0	175
10:00 PM	1	68	15	0	7	0	0	0	0	0	0	0	0	91
11:00 PM	2	45	6	0	4	0	0	0	0	0	0	0	0	57
<b>Total</b>	<b>45</b>	<b>3,452</b>	<b>1,015</b>	<b>36</b>	<b>637</b>	<b>36</b>	<b>0</b>	<b>9</b>	<b>2</b>	<b>2</b>	<b>0</b>	<b>0</b>	<b>0</b>	<b>5,234</b>
<b>Percent</b>	<b>0.9%</b>	<b>66.0%</b>	<b>19.4%</b>	<b>0.7%</b>	<b>12.2%</b>	<b>0.7%</b>	<b>0.0%</b>	<b>0.2%</b>	<b>0.0%</b>	<b>0.0%</b>	<b>0.0%</b>	<b>0.0%</b>	<b>0.0%</b>	

Note: Average only considered on days with 24-hours of data.

**Location:** Old Redwood Highway, BTW Shiloh Rd & Kendall Way  
**Date Range:** 7/28/2022 to 7/28/2022  
**Site Code:** 01

**Total Study Average  
Southbound**

Time	FHWA Vehicle Classification													Total Volume
	1	2	3	4	5	6	7	8	9	10	11	12	13	
12:00 AM	0	10	1	0	1	0	0	0	0	0	0	0	0	12
1:00 AM	0	7	5	0	0	0	0	0	0	0	0	0	0	12
2:00 AM	0	6	2	0	0	0	0	0	0	0	0	0	0	8
3:00 AM	0	7	2	0	6	0	0	0	0	0	0	0	0	15
4:00 AM	0	30	6	0	6	0	0	0	0	0	0	0	0	42
5:00 AM	1	74	31	2	28	14	0	0	0	0	0	0	0	150
6:00 AM	3	136	44	8	40	6	0	0	0	0	0	0	0	237
7:00 AM	6	242	64	4	47	12	0	0	0	0	0	0	0	375
8:00 AM	6	240	74	3	43	10	0	0	0	0	0	0	0	376
9:00 AM	5	226	69	4	19	10	0	0	0	0	0	0	0	333
10:00 AM	5	235	74	1	31	6	0	0	0	0	0	0	0	352
11:00 AM	5	221	69	0	34	1	0	0	0	0	0	0	0	330
12:00 PM	5	256	61	0	37	1	0	0	0	0	0	0	0	360
1:00 PM	9	246	58	0	51	1	0	0	0	0	0	0	0	365
2:00 PM	4	270	68	1	48	2	0	0	0	0	0	0	0	393
3:00 PM	3	269	71	0	36	0	0	0	0	0	0	0	0	379
4:00 PM	4	263	73	0	44	2	0	0	0	0	0	0	0	386
5:00 PM	10	281	75	0	39	0	0	0	0	0	0	0	0	405
6:00 PM	7	230	44	0	20	0	0	0	0	0	0	0	0	301
7:00 PM	2	161	34	0	21	1	0	0	1	0	0	0	0	220
8:00 PM	2	139	31	0	13	0	0	0	0	0	0	0	0	185
9:00 PM	0	97	22	0	6	1	0	0	0	0	0	0	0	126
10:00 PM	0	65	11	0	5	0	0	0	0	0	0	0	0	81
11:00 PM	0	24	6	0	3	0	0	0	0	0	0	0	0	33
<b>Total</b>	<b>77</b>	<b>3,735</b>	<b>995</b>	<b>23</b>	<b>578</b>	<b>67</b>	<b>0</b>	<b>0</b>	<b>1</b>	<b>0</b>	<b>0</b>	<b>0</b>	<b>0</b>	<b>5,476</b>
<b>Percent</b>	<b>1.4%</b>	<b>68.2%</b>	<b>18.2%</b>	<b>0.4%</b>	<b>10.6%</b>	<b>1.2%</b>	<b>0.0%</b>	<b>0.0%</b>	<b>0.0%</b>	<b>0.0%</b>	<b>0.0%</b>	<b>0.0%</b>	<b>0.0%</b>	

Note: Average only considered on days with 24-hours of data.

**Location:** Old Redwood Highway, BTW Shiloh Rd & Kendall Way  
**Date Range:** 7/28/2022 to 7/28/2022  
**Site Code:** 01

**3-Day (Tuesday - Thursday) Average  
 Northbound**

Time	FHWA Vehicle Classification													Total Volume
	1	2	3	4	5	6	7	8	9	10	11	12	13	
12:00 AM	0	17	3	0	2	0	0	0	0	0	0	0	0	22
1:00 AM	0	20	9	0	2	0	0	0	0	0	0	0	0	31
2:00 AM	0	2	3	0	1	0	0	0	0	0	0	0	0	6
3:00 AM	0	4	4	1	2	0	0	0	0	0	0	0	0	11
4:00 AM	1	24	11	2	7	2	0	0	0	0	0	0	0	47
5:00 AM	0	27	3	7	5	6	0	1	0	0	0	0	0	49
6:00 AM	1	34	20	5	15	9	0	1	0	0	0	0	0	85
7:00 AM	2	110	38	9	34	1	0	2	1	0	0	0	0	197
8:00 AM	2	126	48	6	34	2	0	2	0	0	0	0	0	220
9:00 AM	2	172	60	5	24	9	0	2	1	0	0	0	0	275
10:00 AM	4	189	56	1	37	2	0	0	0	0	0	0	0	289
11:00 AM	3	199	60	0	56	0	0	0	0	0	0	0	0	318
12:00 PM	3	211	67	0	42	0	0	1	0	0	0	0	0	324
1:00 PM	2	208	56	0	52	1	0	0	0	1	0	0	0	320
2:00 PM	4	251	79	0	34	2	0	0	0	0	0	0	0	370
3:00 PM	1	333	81	0	44	0	0	0	0	0	0	0	0	459
4:00 PM	3	381	98	0	76	1	0	0	0	0	0	0	0	559
5:00 PM	4	358	105	0	58	1	0	0	0	0	0	0	0	526
6:00 PM	4	206	65	0	38	0	0	0	0	1	0	0	0	314
7:00 PM	2	178	53	0	21	0	0	0	0	0	0	0	0	254
8:00 PM	3	165	43	0	24	0	0	0	0	0	0	0	0	235
9:00 PM	1	124	32	0	18	0	0	0	0	0	0	0	0	175
10:00 PM	1	68	15	0	7	0	0	0	0	0	0	0	0	91
11:00 PM	2	45	6	0	4	0	0	0	0	0	0	0	0	57
<b>Total</b>	<b>45</b>	<b>3,452</b>	<b>1,015</b>	<b>36</b>	<b>637</b>	<b>36</b>	<b>0</b>	<b>9</b>	<b>2</b>	<b>2</b>	<b>0</b>	<b>0</b>	<b>0</b>	<b>5,234</b>
<b>Percent</b>	<b>0.9%</b>	<b>66.0%</b>	<b>19.4%</b>	<b>0.7%</b>	<b>12.2%</b>	<b>0.7%</b>	<b>0.0%</b>	<b>0.2%</b>	<b>0.0%</b>	<b>0.0%</b>	<b>0.0%</b>	<b>0.0%</b>	<b>0.0%</b>	



**Location:** Old Redwood Highway, BTW Shiloh Rd & Kendall Way  
**Date Range:** 7/28/2022 to 7/28/2022  
**Site Code:** 01

**3-Day (Tuesday - Thursday) Average**  
**Southbound**

Time	FHWA Vehicle Classification													Total Volume
	1	2	3	4	5	6	7	8	9	10	11	12	13	
12:00 AM	0	10	1	0	1	0	0	0	0	0	0	0	0	12
1:00 AM	0	7	5	0	0	0	0	0	0	0	0	0	0	12
2:00 AM	0	6	2	0	0	0	0	0	0	0	0	0	0	8
3:00 AM	0	7	2	0	6	0	0	0	0	0	0	0	0	15
4:00 AM	0	30	6	0	6	0	0	0	0	0	0	0	0	42
5:00 AM	1	74	31	2	28	14	0	0	0	0	0	0	0	150
6:00 AM	3	136	44	8	40	6	0	0	0	0	0	0	0	237
7:00 AM	6	242	64	4	47	12	0	0	0	0	0	0	0	375
8:00 AM	6	240	74	3	43	10	0	0	0	0	0	0	0	376
9:00 AM	5	226	69	4	19	10	0	0	0	0	0	0	0	333
10:00 AM	5	235	74	1	31	6	0	0	0	0	0	0	0	352
11:00 AM	5	221	69	0	34	1	0	0	0	0	0	0	0	330
12:00 PM	5	256	61	0	37	1	0	0	0	0	0	0	0	360
1:00 PM	9	246	58	0	51	1	0	0	0	0	0	0	0	365
2:00 PM	4	270	68	1	48	2	0	0	0	0	0	0	0	393
3:00 PM	3	269	71	0	36	0	0	0	0	0	0	0	0	379
4:00 PM	4	263	73	0	44	2	0	0	0	0	0	0	0	386
5:00 PM	10	281	75	0	39	0	0	0	0	0	0	0	0	405
6:00 PM	7	230	44	0	20	0	0	0	0	0	0	0	0	301
7:00 PM	2	161	34	0	21	1	0	0	1	0	0	0	0	220
8:00 PM	2	139	31	0	13	0	0	0	0	0	0	0	0	185
9:00 PM	0	97	22	0	6	1	0	0	0	0	0	0	0	126
10:00 PM	0	65	11	0	5	0	0	0	0	0	0	0	0	81
11:00 PM	0	24	6	0	3	0	0	0	0	0	0	0	0	33
<b>Total</b>	<b>77</b>	<b>3,735</b>	<b>995</b>	<b>23</b>	<b>578</b>	<b>67</b>	<b>0</b>	<b>0</b>	<b>1</b>	<b>0</b>	<b>0</b>	<b>0</b>	<b>0</b>	<b>5,476</b>
<b>Percent</b>	<b>1.4%</b>	<b>68.2%</b>	<b>18.2%</b>	<b>0.4%</b>	<b>10.6%</b>	<b>1.2%</b>	<b>0.0%</b>	<b>0.0%</b>	<b>0.0%</b>	<b>0.0%</b>	<b>0.0%</b>	<b>0.0%</b>	<b>0.0%</b>	

## Vehicle Speed Report Summary

**Location:** Old Redwood Highway, BTW Shiloh Rd & Kendall Way  
**Count Direction:** Northbound / Southbound  
**Date Range:** 7/28/2022 to 7/28/2022  
**Site Code:** 01

	Speed Range (mph)																	Total Volume
	0 - 10	10 - 15	15 - 20	20 - 25	25 - 30	30 - 35	35 - 40	40 - 45	45 - 50	50 - 55	55 - 60	60 - 65	65 - 70	70 - 75	75 - 80	80 - 85	85 +	
<b>Study Total</b>																		
<b>Northbound</b>	4	27	88	173	546	1,864	1,680	620	194	29	4	4	1	0	0	0	0	5,234
<b>Percent</b>	0.1%	0.5%	1.7%	3.3%	10.4%	35.6%	32.1%	11.8%	3.7%	0.6%	0.1%	0.1%	0.0%	0.0%	0.0%	0.0%	0.0%	100%
<b>Southbound</b>	13	55	171	583	1,475	2,051	922	180	25	1	0	0	0	0	0	0	0	5,476
<b>Percent</b>	0.2%	1.0%	3.1%	10.6%	26.9%	37.5%	16.8%	3.3%	0.5%	0.0%	0.0%	0.0%	0.0%	0.0%	0.0%	0.0%	0.0%	100%
<b>Total</b>	17	82	259	756	2,021	3,915	2,602	800	219	30	4	4	1	0	0	0	0	10,710
<b>Percent</b>	0.2%	0.8%	2.4%	7.1%	18.9%	36.6%	24.3%	7.5%	2.0%	0.3%	0.0%	0.0%	0.0%	0.0%	0.0%	0.0%	0.0%	100%

Total Study Percentile Speed Summary			Total Study Speed Statistics		
<b>Northbound</b>			<b>Northbound</b>		
50th Percentile (Median)	34.8	mph	Mean (Average) Speed	34.8	mph
85th Percentile	40.4	mph	10 mph Pace	29.6 - 39.6	mph
95th Percentile	44.5	mph	Percent in Pace	67.8	%
<b>Southbound</b>			<b>Southbound</b>		
50th Percentile (Median)	31.0	mph	Mean (Average) Speed	30.6	mph
85th Percentile	36.0	mph	10 mph Pace	26.3 - 36.3	mph
95th Percentile	39.1	mph	Percent in Pace	66.3	%

**Location:** Old Redwood Highway, BTW Shiloh Rd & Kendall Way  
**Date Range:** 7/28/2022 to 7/28/2022  
**Site Code:** 01

**Thursday, July 28, 2022**  
**Northbound**

Time	Speed Range (mph)																	Total Volume
	0 - 10	10 - 15	15 - 20	20 - 25	25 - 30	30 - 35	35 - 40	40 - 45	45 - 50	50 - 55	55 - 60	60 - 65	65 - 70	70 - 75	75 - 80	80 - 85	85 +	
12:00 AM	0	0	0	0	0	4	13	3	1	1	0	0	0	0	0	0	0	22
1:00 AM	0	0	0	1	1	3	11	8	5	1	1	0	0	0	0	0	0	31
2:00 AM	0	0	0	0	0	2	1	1	2	0	0	0	0	0	0	0	0	6
3:00 AM	0	2	1	1	1	1	3	2	0	0	0	0	0	0	0	0	0	11
4:00 AM	1	2	7	10	12	7	3	4	1	0	0	0	0	0	0	0	0	47
5:00 AM	0	1	11	6	8	11	9	2	1	0	0	0	0	0	0	0	0	49
6:00 AM	0	1	8	17	11	18	16	11	3	0	0	0	0	0	0	0	0	85
7:00 AM	1	3	27	17	26	62	41	15	4	1	0	0	0	0	0	0	0	197
8:00 AM	0	5	6	14	27	90	56	17	4	1	0	0	0	0	0	0	0	220
9:00 AM	1	6	11	31	38	77	84	19	5	2	0	0	1	0	0	0	0	275
10:00 AM	0	0	3	13	45	97	76	49	6	0	0	0	0	0	0	0	0	289
11:00 AM	1	2	3	7	53	131	86	25	9	1	0	0	0	0	0	0	0	318
12:00 PM	0	1	2	9	35	139	100	30	7	1	0	0	0	0	0	0	0	324
1:00 PM	0	1	3	12	48	113	84	39	18	2	0	0	0	0	0	0	0	320
2:00 PM	0	2	1	10	38	133	118	49	17	2	0	0	0	0	0	0	0	370
3:00 PM	0	0	0	6	37	179	183	45	9	0	0	0	0	0	0	0	0	459
4:00 PM	0	0	1	12	67	229	185	54	11	0	0	0	0	0	0	0	0	559
5:00 PM	0	0	0	1	28	227	187	60	19	4	0	0	0	0	0	0	0	526
6:00 PM	0	0	0	1	18	91	136	47	16	3	1	1	0	0	0	0	0	314
7:00 PM	0	0	0	0	16	79	99	40	19	1	0	0	0	0	0	0	0	254
8:00 PM	0	0	1	1	25	82	79	31	13	2	0	1	0	0	0	0	0	235
9:00 PM	0	1	1	0	8	55	57	36	13	4	0	0	0	0	0	0	0	175
10:00 PM	0	0	1	2	2	22	32	21	5	3	2	1	0	0	0	0	0	91
11:00 PM	0	0	1	2	2	12	21	12	6	0	0	1	0	0	0	0	0	57
<b>Total</b>	<b>4</b>	<b>27</b>	<b>88</b>	<b>173</b>	<b>546</b>	<b>1,864</b>	<b>1,680</b>	<b>620</b>	<b>194</b>	<b>29</b>	<b>4</b>	<b>4</b>	<b>1</b>	<b>0</b>	<b>0</b>	<b>0</b>	<b>0</b>	<b>5,234</b>
<b>Percent</b>	<b>0.1%</b>	<b>0.5%</b>	<b>1.7%</b>	<b>3.3%</b>	<b>10.4%</b>	<b>35.6%</b>	<b>32.1%</b>	<b>11.8%</b>	<b>3.7%</b>	<b>0.6%</b>	<b>0.1%</b>	<b>0.1%</b>	<b>0.0%</b>	<b>0.0%</b>	<b>0.0%</b>	<b>0.0%</b>	<b>0.0%</b>	<b>0.0%</b>

Daily Percentile Speed Summary		Speed Statistics	
50th Percentile (Median)	34.8 mph	Mean (Average) Speed	34.8 mph
85th Percentile	40.4 mph	10 mph Pace	29.6 - 39.6 mph
95th Percentile	44.5 mph	Percent in Pace	67.8 %

**Location:** Old Redwood Highway, BTW Shiloh Rd & Kendall Way  
**Date Range:** 7/28/2022 to 7/28/2022  
**Site Code:** 01

**Thursday, July 28, 2022**  
**Southbound**

Time	Speed Range (mph)																	Total Volume
	0 - 10	10 - 15	15 - 20	20 - 25	25 - 30	30 - 35	35 - 40	40 - 45	45 - 50	50 - 55	55 - 60	60 - 65	65 - 70	70 - 75	75 - 80	80 - 85	85 +	
12:00 AM	0	0	0	1	0	3	3	4	1	0	0	0	0	0	0	0	0	12
1:00 AM	0	0	1	0	0	6	2	3	0	0	0	0	0	0	0	0	0	12
2:00 AM	0	0	0	0	2	3	2	0	1	0	0	0	0	0	0	0	0	8
3:00 AM	0	0	0	0	0	1	8	6	0	0	0	0	0	0	0	0	0	15
4:00 AM	0	0	0	0	10	17	8	4	3	0	0	0	0	0	0	0	0	42
5:00 AM	0	1	5	20	42	51	25	5	1	0	0	0	0	0	0	0	0	150
6:00 AM	1	0	4	23	59	90	44	13	3	0	0	0	0	0	0	0	0	237
7:00 AM	1	5	17	63	98	126	53	9	3	0	0	0	0	0	0	0	0	375
8:00 AM	1	2	11	49	116	129	60	7	1	0	0	0	0	0	0	0	0	376
9:00 AM	2	4	11	39	100	128	42	7	0	0	0	0	0	0	0	0	0	333
10:00 AM	1	9	15	50	98	131	41	6	1	0	0	0	0	0	0	0	0	352
11:00 AM	1	3	9	35	109	120	48	4	1	0	0	0	0	0	0	0	0	330
12:00 PM	0	6	13	42	116	135	42	6	0	0	0	0	0	0	0	0	0	360
1:00 PM	1	6	13	44	102	133	53	12	1	0	0	0	0	0	0	0	0	365
2:00 PM	0	2	13	50	145	142	37	4	0	0	0	0	0	0	0	0	0	393
3:00 PM	1	3	20	53	117	121	52	10	2	0	0	0	0	0	0	0	0	379
4:00 PM	2	5	16	38	76	171	64	14	0	0	0	0	0	0	0	0	0	386
5:00 PM	0	5	13	40	99	155	83	9	1	0	0	0	0	0	0	0	0	405
6:00 PM	0	0	4	11	66	128	79	12	1	0	0	0	0	0	0	0	0	301
7:00 PM	2	3	2	8	35	94	65	10	1	0	0	0	0	0	0	0	0	220
8:00 PM	0	1	3	10	48	77	36	9	0	1	0	0	0	0	0	0	0	185
9:00 PM	0	0	0	5	22	58	28	12	1	0	0	0	0	0	0	0	0	126
10:00 PM	0	0	1	1	13	23	32	9	2	0	0	0	0	0	0	0	0	81
11:00 PM	0	0	0	1	2	9	15	5	1	0	0	0	0	0	0	0	0	33
<b>Total</b>	<b>13</b>	<b>55</b>	<b>171</b>	<b>583</b>	<b>1,475</b>	<b>2,051</b>	<b>922</b>	<b>180</b>	<b>25</b>	<b>1</b>	<b>0</b>	<b>0</b>	<b>0</b>	<b>0</b>	<b>0</b>	<b>0</b>	<b>0</b>	<b>5,476</b>
<b>Percent</b>	<b>0.2%</b>	<b>1.0%</b>	<b>3.1%</b>	<b>10.6%</b>	<b>26.9%</b>	<b>37.5%</b>	<b>16.8%</b>	<b>3.3%</b>	<b>0.5%</b>	<b>0.0%</b>	<b>0.0%</b>	<b>0.0%</b>	<b>0.0%</b>	<b>0.0%</b>	<b>0.0%</b>	<b>0.0%</b>	<b>0.0%</b>	<b>0.0%</b>

Daily Percentile Speed Summary		Speed Statistics	
50th Percentile (Median)	31.0 mph	Mean (Average) Speed	30.6 mph
85th Percentile	36.0 mph	10 mph Pace	26.3 - 36.3 mph
95th Percentile	39.1 mph	Percent in Pace	66.29 %

**Location:** Old Redwood Highway, BTW Shiloh Rd & Kendall Way  
**Date Range:** 7/28/2022 to 7/28/2022  
**Site Code:** 01

**Total Study Average  
Northbound**

Time	Speed Range (mph)																	Total Volume
	0 - 10	10 - 15	15 - 20	20 - 25	25 - 30	30 - 35	35 - 40	40 - 45	45 - 50	50 - 55	55 - 60	60 - 65	65 - 70	70 - 75	75 - 80	80 - 85	85 +	
12:00 AM	0	0	0	0	0	4	13	3	1	1	0	0	0	0	0	0	0	22
1:00 AM	0	0	0	1	1	3	11	8	5	1	1	0	0	0	0	0	0	31
2:00 AM	0	0	0	0	0	2	1	1	2	0	0	0	0	0	0	0	0	6
3:00 AM	0	2	1	1	1	1	3	2	0	0	0	0	0	0	0	0	0	11
4:00 AM	1	2	7	10	12	7	3	4	1	0	0	0	0	0	0	0	0	47
5:00 AM	0	1	11	6	8	11	9	2	1	0	0	0	0	0	0	0	0	49
6:00 AM	0	1	8	17	11	18	16	11	3	0	0	0	0	0	0	0	0	85
7:00 AM	1	3	27	17	26	62	41	15	4	1	0	0	0	0	0	0	0	197
8:00 AM	0	5	6	14	27	90	56	17	4	1	0	0	0	0	0	0	0	220
9:00 AM	1	6	11	31	38	77	84	19	5	2	0	0	1	0	0	0	0	275
10:00 AM	0	0	3	13	45	97	76	49	6	0	0	0	0	0	0	0	0	289
11:00 AM	1	2	3	7	53	131	86	25	9	1	0	0	0	0	0	0	0	318
12:00 PM	0	1	2	9	35	139	100	30	7	1	0	0	0	0	0	0	0	324
1:00 PM	0	1	3	12	48	113	84	39	18	2	0	0	0	0	0	0	0	320
2:00 PM	0	2	1	10	38	133	118	49	17	2	0	0	0	0	0	0	0	370
3:00 PM	0	0	0	6	37	179	183	45	9	0	0	0	0	0	0	0	0	459
4:00 PM	0	0	1	12	67	229	185	54	11	0	0	0	0	0	0	0	0	559
5:00 PM	0	0	0	1	28	227	187	60	19	4	0	0	0	0	0	0	0	526
6:00 PM	0	0	0	1	18	91	136	47	16	3	1	1	0	0	0	0	0	314
7:00 PM	0	0	0	0	16	79	99	40	19	1	0	0	0	0	0	0	0	254
8:00 PM	0	0	1	1	25	82	79	31	13	2	0	1	0	0	0	0	0	235
9:00 PM	0	1	1	0	8	55	57	36	13	4	0	0	0	0	0	0	0	175
10:00 PM	0	0	1	2	2	22	32	21	5	3	2	1	0	0	0	0	0	91
11:00 PM	0	0	1	2	2	12	21	12	6	0	0	1	0	0	0	0	0	57
<b>Total</b>	<b>4</b>	<b>27</b>	<b>88</b>	<b>173</b>	<b>546</b>	<b>1,864</b>	<b>1,680</b>	<b>620</b>	<b>194</b>	<b>29</b>	<b>4</b>	<b>4</b>	<b>1</b>	<b>0</b>	<b>0</b>	<b>0</b>	<b>0</b>	<b>5,234</b>
<b>Percent</b>	<b>0.1%</b>	<b>0.5%</b>	<b>1.7%</b>	<b>3.3%</b>	<b>10.4%</b>	<b>35.6%</b>	<b>32.1%</b>	<b>11.8%</b>	<b>3.7%</b>	<b>0.6%</b>	<b>0.1%</b>	<b>0.1%</b>	<b>0.0%</b>	<b>0.0%</b>	<b>0.0%</b>	<b>0.0%</b>	<b>0.0%</b>	<b>0.0%</b>

Note: Average only considered on days with 24-hours of data.

Total Study Percentile Speed Summary		Total Study Speed Statistics	
50th Percentile (Median)	34.8 mph	Mean (Average) Speed	34.8 mph
85th Percentile	40.4 mph	10 mph Pace	29.6 - 39.6 mph
95th Percentile	44.5 mph	Percent in Pace	67.8 %

Location: Old Redwood Highway, BTW Shiloh Rd & Kendall Way  
 Date Range: 7/28/2022 to 7/28/2022  
 Site Code: 01

**Total Study Average  
Southbound**

Time	Speed Range (mph)																	Total Volume
	0 - 10	10 - 15	15 - 20	20 - 25	25 - 30	30 - 35	35 - 40	40 - 45	45 - 50	50 - 55	55 - 60	60 - 65	65 - 70	70 - 75	75 - 80	80 - 85	85 +	
12:00 AM	0	0	0	1	0	3	3	4	1	0	0	0	0	0	0	0	0	12
1:00 AM	0	0	1	0	0	6	2	3	0	0	0	0	0	0	0	0	0	12
2:00 AM	0	0	0	0	2	3	2	0	1	0	0	0	0	0	0	0	0	8
3:00 AM	0	0	0	0	0	1	8	6	0	0	0	0	0	0	0	0	0	15
4:00 AM	0	0	0	0	10	17	8	4	3	0	0	0	0	0	0	0	0	42
5:00 AM	0	1	5	20	42	51	25	5	1	0	0	0	0	0	0	0	0	150
6:00 AM	1	0	4	23	59	90	44	13	3	0	0	0	0	0	0	0	0	237
7:00 AM	1	5	17	63	98	126	53	9	3	0	0	0	0	0	0	0	0	375
8:00 AM	1	2	11	49	116	129	60	7	1	0	0	0	0	0	0	0	0	376
9:00 AM	2	4	11	39	100	128	42	7	0	0	0	0	0	0	0	0	0	333
10:00 AM	1	9	15	50	98	131	41	6	1	0	0	0	0	0	0	0	0	352
11:00 AM	1	3	9	35	109	120	48	4	1	0	0	0	0	0	0	0	0	330
12:00 PM	0	6	13	42	116	135	42	6	0	0	0	0	0	0	0	0	0	360
1:00 PM	1	6	13	44	102	133	53	12	1	0	0	0	0	0	0	0	0	365
2:00 PM	0	2	13	50	145	142	37	4	0	0	0	0	0	0	0	0	0	393
3:00 PM	1	3	20	53	117	121	52	10	2	0	0	0	0	0	0	0	0	379
4:00 PM	2	5	16	38	76	171	64	14	0	0	0	0	0	0	0	0	0	386
5:00 PM	0	5	13	40	99	155	83	9	1	0	0	0	0	0	0	0	0	405
6:00 PM	0	0	4	11	66	128	79	12	1	0	0	0	0	0	0	0	0	301
7:00 PM	2	3	2	8	35	94	65	10	1	0	0	0	0	0	0	0	0	220
8:00 PM	0	1	3	10	48	77	36	9	0	1	0	0	0	0	0	0	0	185
9:00 PM	0	0	0	5	22	58	28	12	1	0	0	0	0	0	0	0	0	126
10:00 PM	0	0	1	1	13	23	32	9	2	0	0	0	0	0	0	0	0	81
11:00 PM	0	0	0	1	2	9	15	5	1	0	0	0	0	0	0	0	0	33
<b>Total</b>	<b>13</b>	<b>55</b>	<b>171</b>	<b>583</b>	<b>1,475</b>	<b>2,051</b>	<b>922</b>	<b>180</b>	<b>25</b>	<b>1</b>	<b>0</b>	<b>0</b>	<b>0</b>	<b>0</b>	<b>0</b>	<b>0</b>	<b>0</b>	<b>5,476</b>
<b>Percent</b>	<b>0.2%</b>	<b>1.0%</b>	<b>3.1%</b>	<b>10.6%</b>	<b>26.9%</b>	<b>37.5%</b>	<b>16.8%</b>	<b>3.3%</b>	<b>0.5%</b>	<b>0.0%</b>	<b>0.0%</b>	<b>0.0%</b>	<b>0.0%</b>	<b>0.0%</b>	<b>0.0%</b>	<b>0.0%</b>	<b>0.0%</b>	<b>0.0%</b>

Note: Average only considered on days with 24-hours of data.

Total Study Percentile Speed Summary		Total Study Speed Statistics	
50th Percentile (Median)	31.0 mph	Mean (Average) Speed	30.6 mph
85th Percentile	36.0 mph	10 mph Pace	26.3 - 36.3 mph
95th Percentile	39.1 mph	Percent in Pace	66.3 %

Location: Old Redwood Highway, BTW Shiloh Rd & Kendall Way  
 Date Range: 7/28/2022 - 8/3/2022  
 Site Code: 01

Time	Thursday			Friday			Saturday			Sunday			Monday			Tuesday			Wednesday			Mid-Week Average		
	7/28/2022			7/29/2022			7/30/2022			7/31/2022			8/1/2022			8/2/2022			8/3/2022					
	NB	SB	Total	NB	SB	Total	NB	SB	Total	NB	SB	Total	NB	SB	Total	NB	SB	Total	NB	SB	Total	NB	SB	Total
12:00 AM	22	12	34	-	-	-	-	-	-	-	-	-	-	-	-	-	-	-	-	-	-	22	12	34
1:00 AM	31	12	43	-	-	-	-	-	-	-	-	-	-	-	-	-	-	-	-	-	-	31	12	43
2:00 AM	6	8	14	-	-	-	-	-	-	-	-	-	-	-	-	-	-	-	-	-	-	6	8	14
3:00 AM	11	15	26	-	-	-	-	-	-	-	-	-	-	-	-	-	-	-	-	-	-	11	15	26
4:00 AM	47	42	89	-	-	-	-	-	-	-	-	-	-	-	-	-	-	-	-	-	-	47	42	89
5:00 AM	49	150	199	-	-	-	-	-	-	-	-	-	-	-	-	-	-	-	-	-	-	49	150	199
6:00 AM	85	237	322	-	-	-	-	-	-	-	-	-	-	-	-	-	-	-	-	-	-	85	237	322
7:00 AM	197	375	572	-	-	-	-	-	-	-	-	-	-	-	-	-	-	-	-	-	-	197	375	572
8:00 AM	220	376	596	-	-	-	-	-	-	-	-	-	-	-	-	-	-	-	-	-	-	220	376	596
9:00 AM	275	333	608	-	-	-	-	-	-	-	-	-	-	-	-	-	-	-	-	-	-	275	333	608
10:00 AM	289	352	641	-	-	-	-	-	-	-	-	-	-	-	-	-	-	-	-	-	-	289	352	641
11:00 AM	318	330	648	-	-	-	-	-	-	-	-	-	-	-	-	-	-	-	-	-	-	318	330	648
12:00 PM	324	360	684	-	-	-	-	-	-	-	-	-	-	-	-	-	-	-	-	-	-	324	360	684
1:00 PM	320	365	685	-	-	-	-	-	-	-	-	-	-	-	-	-	-	-	-	-	-	320	365	685
2:00 PM	370	393	763	-	-	-	-	-	-	-	-	-	-	-	-	-	-	-	-	-	-	370	393	763
3:00 PM	459	379	838	-	-	-	-	-	-	-	-	-	-	-	-	-	-	-	-	-	-	459	379	838
4:00 PM	559	386	945	-	-	-	-	-	-	-	-	-	-	-	-	-	-	-	-	-	-	559	386	945
5:00 PM	526	405	931	-	-	-	-	-	-	-	-	-	-	-	-	-	-	-	-	-	-	526	405	931
6:00 PM	314	301	615	-	-	-	-	-	-	-	-	-	-	-	-	-	-	-	-	-	-	314	301	615
7:00 PM	254	220	474	-	-	-	-	-	-	-	-	-	-	-	-	-	-	-	-	-	-	254	220	474
8:00 PM	235	185	420	-	-	-	-	-	-	-	-	-	-	-	-	-	-	-	-	-	-	235	185	420
9:00 PM	175	126	301	-	-	-	-	-	-	-	-	-	-	-	-	-	-	-	-	-	-	175	126	301
10:00 PM	91	81	172	-	-	-	-	-	-	-	-	-	-	-	-	-	-	-	-	-	-	91	81	172
11:00 PM	57	33	90	-	-	-	-	-	-	-	-	-	-	-	-	-	-	-	-	-	-	57	33	90
Total	5,234	5,476	10,710	-	-	-	-	-	-	-	-	-	-	-	-	-	-	-	-	-	-	5,234	5,476	10,710
Percent	49%	51%	-	-	-	-	-	-	-	-	-	-	-	-	-	-	-	-	-	-	-	49%	51%	-
AM Peak	11:00	08:00	11:00	-	-	-	-	-	-	-	-	-	-	-	-	-	-	-	-	-	-	11:00	08:00	11:00
Vol.	318	376	648	-	-	-	-	-	-	-	-	-	-	-	-	-	-	-	-	-	-	318	376	648
PM Peak	16:00	17:00	16:00	-	-	-	-	-	-	-	-	-	-	-	-	-	-	-	-	-	-	16:00	17:00	16:00
Vol.	559	405	945	-	-	-	-	-	-	-	-	-	-	-	-	-	-	-	-	-	-	559	405	945

1. Mid-week average includes data between Tuesday and Thursday.

## Vehicle Classification Report Summary



**Location:** Old Redwood Highway, BTW Shiloh Rd & Lafayette Dr  
**Count Direction:** Northbound / Southbound  
**Date Range:** 7/28/2022 to 7/28/2022  
**Site Code:** 02

	FHWA Vehicle Classification													Total Volume
	1	2	3	4	5	6	7	8	9	10	11	12	13	
<b>Study Total</b>														
<b>Northbound</b>	38	3,251	934	2	583	5	0	1	0	1	0	0	0	4,815
<b>Percent</b>	0.8%	67.5%	19.4%	0.0%	12.1%	0.1%	0.0%	0.0%	0.0%	0.0%	0.0%	0.0%	0.0%	100%
<b>Southbound</b>	66	3,609	993	13	353	72	0	3	6	0	0	1	0	5,116
<b>Percent</b>	1.3%	70.5%	19.4%	0.3%	6.9%	1.4%	0.0%	0.1%	0.1%	0.0%	0.0%	0.0%	0.0%	100%
<b>Total</b>	104	6,860	1,927	15	936	77	0	4	6	1	0	1	0	9,931
<b>Percent</b>	1.0%	69.1%	19.4%	0.2%	9.4%	0.8%	0.0%	0.0%	0.1%	0.0%	0.0%	0.0%	0.0%	100%

<b>FHWA Vehicle Classification</b>	
Class 1 - Motorcycles	Class 8 - Four or Fewer Axle Single-Trailer Trucks
Class 2 - Passenger Cars	Class 9 - Five-Axle Single-Trailer Trucks
Class 3 - Other Two-Axle, Four-Tire Single Unit Vehicles	Class 10 - Six or More Axle Single-Trailer Trucks
Class 4 - Buses	Class 11 - Five or fewer Axle Multi-Trailer Trucks
Class 5 - Two-Axle, Six-Tire, Single-Unit Trucks	Class 12 - Six-Axle Multi-Trailer Trucks
Class 6 - Three-Axle Single-Unit Trucks	Class 13 - Seven or More Axle Multi-Trailer Trucks
Class 7 - Four or More Axle Single-Unit Trucks	



**Location:** Old Redwood Highway, BTW Shiloh Rd & Lafayette Dr  
**Date Range:** 7/28/2022 to 7/28/2022  
**Site Code:** 02

**Thursday, July 28, 2022**  
**Northbound**

Time	FHWA Vehicle Classification													Total Volume
	1	2	3	4	5	6	7	8	9	10	11	12	13	
12:00 AM	0	9	2	0	0	0	0	0	0	0	0	0	0	11
1:00 AM	0	17	7	0	1	0	0	0	0	0	0	0	0	25
2:00 AM	0	3	3	1	2	0	0	0	0	0	0	0	0	9
3:00 AM	0	2	3	0	1	0	0	0	0	0	0	0	0	6
4:00 AM	0	13	3	0	2	0	0	0	0	0	0	0	0	18
5:00 AM	0	38	14	0	6	0	0	0	0	0	0	0	0	58
6:00 AM	1	53	24	0	22	0	0	0	0	0	0	0	0	100
7:00 AM	1	110	39	0	42	1	0	0	0	0	0	0	0	193
8:00 AM	2	126	55	0	43	0	0	0	0	0	0	0	0	226
9:00 AM	3	162	59	0	29	0	0	0	0	0	0	0	0	253
10:00 AM	2	198	65	0	41	0	0	0	0	0	0	0	0	306
11:00 AM	1	211	61	0	34	0	0	0	0	0	0	0	0	307
12:00 PM	2	212	79	0	40	2	0	0	0	0	0	0	0	335
1:00 PM	2	213	52	0	54	1	0	0	0	0	0	0	0	322
2:00 PM	3	226	63	0	39	1	0	0	0	0	0	0	0	332
3:00 PM	1	297	79	1	40	0	0	0	0	0	0	0	0	418
4:00 PM	7	337	84	0	49	0	0	0	0	1	0	0	0	478
5:00 PM	6	349	75	0	48	0	0	0	0	0	0	0	0	478
6:00 PM	3	209	63	0	31	0	0	0	0	0	0	0	0	306
7:00 PM	2	153	42	0	17	0	0	1	0	0	0	0	0	215
8:00 PM	1	126	30	0	20	0	0	0	0	0	0	0	0	177
9:00 PM	0	103	21	0	14	0	0	0	0	0	0	0	0	138
10:00 PM	0	56	8	0	6	0	0	0	0	0	0	0	0	70
11:00 PM	1	28	3	0	2	0	0	0	0	0	0	0	0	34
<b>Total</b>	<b>38</b>	<b>3,251</b>	<b>934</b>	<b>2</b>	<b>583</b>	<b>5</b>	<b>0</b>	<b>1</b>	<b>0</b>	<b>1</b>	<b>0</b>	<b>0</b>	<b>0</b>	<b>4,815</b>
<b>Percent</b>	<b>0.8%</b>	<b>67.5%</b>	<b>19.4%</b>	<b>0.0%</b>	<b>12.1%</b>	<b>0.1%</b>	<b>0.0%</b>	<b>0.0%</b>	<b>0.0%</b>	<b>0.0%</b>	<b>0.0%</b>	<b>0.0%</b>	<b>0.0%</b>	

**Location:** Old Redwood Highway, BTW Shiloh Rd & Lafayette Dr  
**Date Range:** 7/28/2022 to 7/28/2022  
**Site Code:** 02

**Thursday, July 28, 2022**  
**Southbound**

Time	FHWA Vehicle Classification													Total Volume
	1	2	3	4	5	6	7	8	9	10	11	12	13	
12:00 AM	0	10	1	0	0	0	0	0	0	0	0	0	0	11
1:00 AM	0	7	3	0	0	0	0	0	0	0	0	0	0	10
2:00 AM	0	3	1	0	1	0	0	0	0	0	0	0	0	5
3:00 AM	0	7	2	0	0	0	0	0	0	0	0	0	0	9
4:00 AM	1	17	4	0	1	0	0	0	0	0	0	0	0	23
5:00 AM	0	50	21	0	4	0	0	0	0	0	0	0	0	75
6:00 AM	2	86	31	0	20	0	0	0	0	0	0	0	0	139
7:00 AM	4	206	53	0	22	2	0	0	1	0	0	0	0	288
8:00 AM	4	189	57	0	21	35	0	0	1	0	0	0	0	307
9:00 AM	1	194	59	1	13	17	0	0	0	0	0	1	0	286
10:00 AM	7	216	66	0	27	5	0	1	0	0	0	0	0	322
11:00 AM	3	198	70	2	23	1	0	0	0	0	0	0	0	297
12:00 PM	6	241	78	1	29	3	0	0	0	0	0	0	0	358
1:00 PM	6	269	63	1	34	0	0	1	1	0	0	0	0	375
2:00 PM	5	296	74	1	19	2	0	0	0	0	0	0	0	397
3:00 PM	4	301	91	0	33	2	0	0	1	0	0	0	0	432
4:00 PM	5	307	87	1	33	2	0	0	1	0	0	0	0	436
5:00 PM	6	282	75	0	24	1	0	0	0	0	0	0	0	388
6:00 PM	6	231	53	1	13	1	0	0	0	0	0	0	0	305
7:00 PM	3	157	35	1	12	1	0	0	1	0	0	0	0	210
8:00 PM	2	144	31	1	11	0	0	1	0	0	0	0	0	190
9:00 PM	0	117	22	2	7	0	0	0	0	0	0	0	0	148
10:00 PM	1	57	12	1	5	0	0	0	0	0	0	0	0	76
11:00 PM	0	24	4	0	1	0	0	0	0	0	0	0	0	29
<b>Total</b>	<b>66</b>	<b>3,609</b>	<b>993</b>	<b>13</b>	<b>353</b>	<b>72</b>	<b>0</b>	<b>3</b>	<b>6</b>	<b>0</b>	<b>0</b>	<b>1</b>	<b>0</b>	<b>5,116</b>
<b>Percent</b>	<b>1.3%</b>	<b>70.5%</b>	<b>19.4%</b>	<b>0.3%</b>	<b>6.9%</b>	<b>1.4%</b>	<b>0.0%</b>	<b>0.1%</b>	<b>0.1%</b>	<b>0.0%</b>	<b>0.0%</b>	<b>0.0%</b>	<b>0.0%</b>	

**Location:** Old Redwood Highway, BTW Shiloh Rd & Lafayette Dr  
**Date Range:** 7/28/2022 to 7/28/2022  
**Site Code:** 02

**Total Study Average  
Northbound**

Time	FHWA Vehicle Classification													Total Volume
	1	2	3	4	5	6	7	8	9	10	11	12	13	
12:00 AM	0	9	2	0	0	0	0	0	0	0	0	0	0	11
1:00 AM	0	17	7	0	1	0	0	0	0	0	0	0	0	25
2:00 AM	0	3	3	1	2	0	0	0	0	0	0	0	0	9
3:00 AM	0	2	3	0	1	0	0	0	0	0	0	0	0	6
4:00 AM	0	13	3	0	2	0	0	0	0	0	0	0	0	18
5:00 AM	0	38	14	0	6	0	0	0	0	0	0	0	0	58
6:00 AM	1	53	24	0	22	0	0	0	0	0	0	0	0	100
7:00 AM	1	110	39	0	42	1	0	0	0	0	0	0	0	193
8:00 AM	2	126	55	0	43	0	0	0	0	0	0	0	0	226
9:00 AM	3	162	59	0	29	0	0	0	0	0	0	0	0	253
10:00 AM	2	198	65	0	41	0	0	0	0	0	0	0	0	306
11:00 AM	1	211	61	0	34	0	0	0	0	0	0	0	0	307
12:00 PM	2	212	79	0	40	2	0	0	0	0	0	0	0	335
1:00 PM	2	213	52	0	54	1	0	0	0	0	0	0	0	322
2:00 PM	3	226	63	0	39	1	0	0	0	0	0	0	0	332
3:00 PM	1	297	79	1	40	0	0	0	0	0	0	0	0	418
4:00 PM	7	337	84	0	49	0	0	0	0	1	0	0	0	478
5:00 PM	6	349	75	0	48	0	0	0	0	0	0	0	0	478
6:00 PM	3	209	63	0	31	0	0	0	0	0	0	0	0	306
7:00 PM	2	153	42	0	17	0	0	1	0	0	0	0	0	215
8:00 PM	1	126	30	0	20	0	0	0	0	0	0	0	0	177
9:00 PM	0	103	21	0	14	0	0	0	0	0	0	0	0	138
10:00 PM	0	56	8	0	6	0	0	0	0	0	0	0	0	70
11:00 PM	1	28	3	0	2	0	0	0	0	0	0	0	0	34
<b>Total</b>	<b>38</b>	<b>3,251</b>	<b>934</b>	<b>2</b>	<b>583</b>	<b>5</b>	<b>0</b>	<b>1</b>	<b>0</b>	<b>1</b>	<b>0</b>	<b>0</b>	<b>0</b>	<b>4,815</b>
<b>Percent</b>	<b>0.8%</b>	<b>67.5%</b>	<b>19.4%</b>	<b>0.0%</b>	<b>12.1%</b>	<b>0.1%</b>	<b>0.0%</b>	<b>0.0%</b>	<b>0.0%</b>	<b>0.0%</b>	<b>0.0%</b>	<b>0.0%</b>	<b>0.0%</b>	

Note: Average only considered on days with 24-hours of data.

**Location:** Old Redwood Highway, BTW Shiloh Rd & Lafayette Dr  
**Date Range:** 7/28/2022 to 7/28/2022  
**Site Code:** 02

**Total Study Average  
Southbound**

Time	FHWA Vehicle Classification													Total Volume	
	1	2	3	4	5	6	7	8	9	10	11	12	13		
12:00 AM	0	10	1	0	0	0	0	0	0	0	0	0	0	0	11
1:00 AM	0	7	3	0	0	0	0	0	0	0	0	0	0	0	10
2:00 AM	0	3	1	0	1	0	0	0	0	0	0	0	0	0	5
3:00 AM	0	7	2	0	0	0	0	0	0	0	0	0	0	0	9
4:00 AM	1	17	4	0	1	0	0	0	0	0	0	0	0	0	23
5:00 AM	0	50	21	0	4	0	0	0	0	0	0	0	0	0	75
6:00 AM	2	86	31	0	20	0	0	0	0	0	0	0	0	0	139
7:00 AM	4	206	53	0	22	2	0	0	1	0	0	0	0	0	288
8:00 AM	4	189	57	0	21	35	0	0	1	0	0	0	0	0	307
9:00 AM	1	194	59	1	13	17	0	0	0	0	0	1	0	0	286
10:00 AM	7	216	66	0	27	5	0	1	0	0	0	0	0	0	322
11:00 AM	3	198	70	2	23	1	0	0	0	0	0	0	0	0	297
12:00 PM	6	241	78	1	29	3	0	0	0	0	0	0	0	0	358
1:00 PM	6	269	63	1	34	0	0	1	1	0	0	0	0	0	375
2:00 PM	5	296	74	1	19	2	0	0	0	0	0	0	0	0	397
3:00 PM	4	301	91	0	33	2	0	0	1	0	0	0	0	0	432
4:00 PM	5	307	87	1	33	2	0	0	1	0	0	0	0	0	436
5:00 PM	6	282	75	0	24	1	0	0	0	0	0	0	0	0	388
6:00 PM	6	231	53	1	13	1	0	0	0	0	0	0	0	0	305
7:00 PM	3	157	35	1	12	1	0	0	1	0	0	0	0	0	210
8:00 PM	2	144	31	1	11	0	0	1	0	0	0	0	0	0	190
9:00 PM	0	117	22	2	7	0	0	0	0	0	0	0	0	0	148
10:00 PM	1	57	12	1	5	0	0	0	0	0	0	0	0	0	76
11:00 PM	0	24	4	0	1	0	0	0	0	0	0	0	0	0	29
<b>Total</b>	<b>66</b>	<b>3,609</b>	<b>993</b>	<b>13</b>	<b>353</b>	<b>72</b>	<b>0</b>	<b>3</b>	<b>6</b>	<b>0</b>	<b>0</b>	<b>1</b>	<b>0</b>	<b>0</b>	<b>5,116</b>
<b>Percent</b>	<b>1.3%</b>	<b>70.5%</b>	<b>19.4%</b>	<b>0.3%</b>	<b>6.9%</b>	<b>1.4%</b>	<b>0.0%</b>	<b>0.1%</b>	<b>0.1%</b>	<b>0.0%</b>	<b>0.0%</b>	<b>0.0%</b>	<b>0.0%</b>	<b>0.0%</b>	

Note: Average only considered on days with 24-hours of data.

**Location:** Old Redwood Highway, BTW Shiloh Rd & Lafayette Dr  
**Date Range:** 7/28/2022 to 7/28/2022  
**Site Code:** 02

**3-Day (Tuesday - Thursday) Average  
 Northbound**

Time	FHWA Vehicle Classification													Total Volume
	1	2	3	4	5	6	7	8	9	10	11	12	13	
12:00 AM	0	9	2	0	0	0	0	0	0	0	0	0	0	11
1:00 AM	0	17	7	0	1	0	0	0	0	0	0	0	0	25
2:00 AM	0	3	3	1	2	0	0	0	0	0	0	0	0	9
3:00 AM	0	2	3	0	1	0	0	0	0	0	0	0	0	6
4:00 AM	0	13	3	0	2	0	0	0	0	0	0	0	0	18
5:00 AM	0	38	14	0	6	0	0	0	0	0	0	0	0	58
6:00 AM	1	53	24	0	22	0	0	0	0	0	0	0	0	100
7:00 AM	1	110	39	0	42	1	0	0	0	0	0	0	0	193
8:00 AM	2	126	55	0	43	0	0	0	0	0	0	0	0	226
9:00 AM	3	162	59	0	29	0	0	0	0	0	0	0	0	253
10:00 AM	2	198	65	0	41	0	0	0	0	0	0	0	0	306
11:00 AM	1	211	61	0	34	0	0	0	0	0	0	0	0	307
12:00 PM	2	212	79	0	40	2	0	0	0	0	0	0	0	335
1:00 PM	2	213	52	0	54	1	0	0	0	0	0	0	0	322
2:00 PM	3	226	63	0	39	1	0	0	0	0	0	0	0	332
3:00 PM	1	297	79	1	40	0	0	0	0	0	0	0	0	418
4:00 PM	7	337	84	0	49	0	0	0	0	1	0	0	0	478
5:00 PM	6	349	75	0	48	0	0	0	0	0	0	0	0	478
6:00 PM	3	209	63	0	31	0	0	0	0	0	0	0	0	306
7:00 PM	2	153	42	0	17	0	0	1	0	0	0	0	0	215
8:00 PM	1	126	30	0	20	0	0	0	0	0	0	0	0	177
9:00 PM	0	103	21	0	14	0	0	0	0	0	0	0	0	138
10:00 PM	0	56	8	0	6	0	0	0	0	0	0	0	0	70
11:00 PM	1	28	3	0	2	0	0	0	0	0	0	0	0	34
<b>Total</b>	<b>38</b>	<b>3,251</b>	<b>934</b>	<b>2</b>	<b>583</b>	<b>5</b>	<b>0</b>	<b>1</b>	<b>0</b>	<b>1</b>	<b>0</b>	<b>0</b>	<b>0</b>	<b>4,815</b>
<b>Percent</b>	<b>0.8%</b>	<b>67.5%</b>	<b>19.4%</b>	<b>0.0%</b>	<b>12.1%</b>	<b>0.1%</b>	<b>0.0%</b>	<b>0.0%</b>	<b>0.0%</b>	<b>0.0%</b>	<b>0.0%</b>	<b>0.0%</b>	<b>0.0%</b>	

**Location:** Old Redwood Highway, BTW Shiloh Rd & Lafayette Dr  
**Date Range:** 7/28/2022 to 7/28/2022  
**Site Code:** 02

**3-Day (Tuesday - Thursday) Average  
 Southbound**

Time	FHWA Vehicle Classification													Total Volume
	1	2	3	4	5	6	7	8	9	10	11	12	13	
12:00 AM	0	10	1	0	0	0	0	0	0	0	0	0	0	11
1:00 AM	0	7	3	0	0	0	0	0	0	0	0	0	0	10
2:00 AM	0	3	1	0	1	0	0	0	0	0	0	0	0	5
3:00 AM	0	7	2	0	0	0	0	0	0	0	0	0	0	9
4:00 AM	1	17	4	0	1	0	0	0	0	0	0	0	0	23
5:00 AM	0	50	21	0	4	0	0	0	0	0	0	0	0	75
6:00 AM	2	86	31	0	20	0	0	0	0	0	0	0	0	139
7:00 AM	4	206	53	0	22	2	0	0	1	0	0	0	0	288
8:00 AM	4	189	57	0	21	35	0	0	1	0	0	0	0	307
9:00 AM	1	194	59	1	13	17	0	0	0	0	0	1	0	286
10:00 AM	7	216	66	0	27	5	0	1	0	0	0	0	0	322
11:00 AM	3	198	70	2	23	1	0	0	0	0	0	0	0	297
12:00 PM	6	241	78	1	29	3	0	0	0	0	0	0	0	358
1:00 PM	6	269	63	1	34	0	0	1	1	0	0	0	0	375
2:00 PM	5	296	74	1	19	2	0	0	0	0	0	0	0	397
3:00 PM	4	301	91	0	33	2	0	0	1	0	0	0	0	432
4:00 PM	5	307	87	1	33	2	0	0	1	0	0	0	0	436
5:00 PM	6	282	75	0	24	1	0	0	0	0	0	0	0	388
6:00 PM	6	231	53	1	13	1	0	0	0	0	0	0	0	305
7:00 PM	3	157	35	1	12	1	0	0	1	0	0	0	0	210
8:00 PM	2	144	31	1	11	0	0	1	0	0	0	0	0	190
9:00 PM	0	117	22	2	7	0	0	0	0	0	0	0	0	148
10:00 PM	1	57	12	1	5	0	0	0	0	0	0	0	0	76
11:00 PM	0	24	4	0	1	0	0	0	0	0	0	0	0	29
<b>Total</b>	<b>66</b>	<b>3,609</b>	<b>993</b>	<b>13</b>	<b>353</b>	<b>72</b>	<b>0</b>	<b>3</b>	<b>6</b>	<b>0</b>	<b>0</b>	<b>1</b>	<b>0</b>	<b>5,116</b>
<b>Percent</b>	<b>1.3%</b>	<b>70.5%</b>	<b>19.4%</b>	<b>0.3%</b>	<b>6.9%</b>	<b>1.4%</b>	<b>0.0%</b>	<b>0.1%</b>	<b>0.1%</b>	<b>0.0%</b>	<b>0.0%</b>	<b>0.0%</b>	<b>0.0%</b>	

## Vehicle Speed Report Summary

**Location:** Old Redwood Highway, BTW Shiloh Rd & Lafayette Dr  
**Count Direction:** Northbound / Southbound  
**Date Range:** 7/28/2022 to 7/28/2022  
**Site Code:** 02

	Speed Range (mph)																	Total Volume
	0 - 10	10 - 15	15 - 20	20 - 25	25 - 30	30 - 35	35 - 40	40 - 45	45 - 50	50 - 55	55 - 60	60 - 65	65 - 70	70 - 75	75 - 80	80 - 85	85 +	
<b>Study Total</b>																		
<b>Northbound</b>	7	23	88	172	561	1,322	1,568	787	234	50	2	1	0	0	0	0	0	4,815
<b>Percent</b>	0.1%	0.5%	1.8%	3.6%	11.7%	27.5%	32.6%	16.3%	4.9%	1.0%	0.0%	0.0%	0.0%	0.0%	0.0%	0.0%	0.0%	100%
<b>Southbound</b>	1	19	27	40	174	1,531	2,496	711	98	16	3	0	0	0	0	0	0	5,116
<b>Percent</b>	0.0%	0.4%	0.5%	0.8%	3.4%	29.9%	48.8%	13.9%	1.9%	0.3%	0.1%	0.0%	0.0%	0.0%	0.0%	0.0%	0.0%	100%
<b>Total</b>	8	42	115	212	735	2,853	4,064	1,498	332	66	5	1	0	0	0	0	0	9,931
<b>Percent</b>	0.1%	0.4%	1.2%	2.1%	7.4%	28.7%	40.9%	15.1%	3.3%	0.7%	0.1%	0.0%	0.0%	0.0%	0.0%	0.0%	0.0%	100%

Total Study Percentile Speed Summary			Total Study Speed Statistics		
<b>Northbound</b>			<b>Northbound</b>		
50th Percentile (Median)	35.7	mph	Mean (Average) Speed	35.4	mph
85th Percentile	41.7	mph	10 mph Pace	30.9 - 40.9	mph
95th Percentile	45.6	mph	Percent in Pace	60.3	%
<b>Southbound</b>			<b>Southbound</b>		
50th Percentile (Median)	36.2	mph	Mean (Average) Speed	36.3	mph
85th Percentile	40.3	mph	10 mph Pace	31.7 - 41.7	mph
95th Percentile	43.2	mph	Percent in Pace	81.2	%

**Location:** Old Redwood Highway, BTW Shiloh Rd & Lafayette Dr  
**Date Range:** 7/28/2022 to 7/28/2022  
**Site Code:** 02

**Thursday, July 28, 2022**  
**Northbound**

Time	Speed Range (mph)																	Total Volume
	0 - 10	10 - 15	15 - 20	20 - 25	25 - 30	30 - 35	35 - 40	40 - 45	45 - 50	50 - 55	55 - 60	60 - 65	65 - 70	70 - 75	75 - 80	80 - 85	85 +	
12:00 AM	0	0	1	0	0	3	3	1	2	1	0	0	0	0	0	0	0	11
1:00 AM	0	0	0	0	2	3	3	10	4	3	0	0	0	0	0	0	0	25
2:00 AM	0	0	0	1	1	2	2	1	1	1	0	0	0	0	0	0	0	9
3:00 AM	0	0	0	1	1	0	4	0	0	0	0	0	0	0	0	0	0	6
4:00 AM	0	0	0	0	0	6	7	3	2	0	0	0	0	0	0	0	0	18
5:00 AM	0	0	0	2	2	12	22	15	4	1	0	0	0	0	0	0	0	58
6:00 AM	0	0	0	0	7	26	36	22	6	3	0	0	0	0	0	0	0	100
7:00 AM	0	0	0	3	10	59	77	34	10	0	0	0	0	0	0	0	0	193
8:00 AM	0	1	1	3	18	66	89	36	10	2	0	0	0	0	0	0	0	226
9:00 AM	0	0	5	0	19	55	106	54	12	2	0	0	0	0	0	0	0	253
10:00 AM	0	0	3	15	40	101	101	34	10	2	0	0	0	0	0	0	0	306
11:00 AM	0	0	3	9	30	90	116	44	12	3	0	0	0	0	0	0	0	307
12:00 PM	0	0	3	9	44	111	108	54	5	1	0	0	0	0	0	0	0	335
1:00 PM	0	4	4	14	44	86	102	50	15	3	0	0	0	0	0	0	0	322
2:00 PM	1	1	3	7	46	95	96	53	25	5	0	0	0	0	0	0	0	332
3:00 PM	0	1	3	17	80	124	132	45	15	1	0	0	0	0	0	0	0	418
4:00 PM	3	8	30	37	72	125	122	65	12	4	0	0	0	0	0	0	0	478
5:00 PM	3	6	27	35	75	127	102	74	25	3	1	0	0	0	0	0	0	478
6:00 PM	0	0	3	8	21	77	121	57	17	2	0	0	0	0	0	0	0	306
7:00 PM	0	1	0	1	9	42	88	58	13	3	0	0	0	0	0	0	0	215
8:00 PM	0	0	1	5	14	58	53	31	12	2	0	1	0	0	0	0	0	177
9:00 PM	0	1	0	4	24	34	45	18	7	5	0	0	0	0	0	0	0	138
10:00 PM	0	0	1	1	1	14	22	21	8	2	0	0	0	0	0	0	0	70
11:00 PM	0	0	0	0	1	6	11	7	7	1	1	0	0	0	0	0	0	34
<b>Total</b>	<b>7</b>	<b>23</b>	<b>88</b>	<b>172</b>	<b>561</b>	<b>1,322</b>	<b>1,568</b>	<b>787</b>	<b>234</b>	<b>50</b>	<b>2</b>	<b>1</b>	<b>0</b>	<b>0</b>	<b>0</b>	<b>0</b>	<b>0</b>	<b>4,815</b>
<b>Percent</b>	<b>0.1%</b>	<b>0.5%</b>	<b>1.8%</b>	<b>3.6%</b>	<b>11.7%</b>	<b>27.5%</b>	<b>32.6%</b>	<b>16.3%</b>	<b>4.9%</b>	<b>1.0%</b>	<b>0.0%</b>	<b>0.0%</b>	<b>0.0%</b>	<b>0.0%</b>	<b>0.0%</b>	<b>0.0%</b>	<b>0.0%</b>	<b>0.0%</b>

Daily Percentile Speed Summary		Speed Statistics	
50th Percentile (Median)	35.7 mph	Mean (Average) Speed	35.4 mph
85th Percentile	41.7 mph	10 mph Pace	30.9 - 40.9 mph
95th Percentile	45.6 mph	Percent in Pace	60.3 %



Location: Old Redwood Highway, BTW Shiloh Rd & Lafayette Dr  
 Date Range: 7/28/2022 to 7/28/2022  
 Site Code: 02

Thursday, July 28, 2022  
 Southbound

Time	Speed Range (mph)																	Total Volume
	0 - 10	10 - 15	15 - 20	20 - 25	25 - 30	30 - 35	35 - 40	40 - 45	45 - 50	50 - 55	55 - 60	60 - 65	65 - 70	70 - 75	75 - 80	80 - 85	85 +	
12:00 AM	0	0	0	0	0	3	3	3	1	1	0	0	0	0	0	0	0	11
1:00 AM	0	0	0	0	1	3	1	5	0	0	0	0	0	0	0	0	0	10
2:00 AM	0	0	1	0	0	3	1	0	0	0	0	0	0	0	0	0	0	5
3:00 AM	0	0	0	0	0	2	2	3	2	0	0	0	0	0	0	0	0	9
4:00 AM	0	0	1	0	0	5	8	6	2	1	0	0	0	0	0	0	0	23
5:00 AM	0	0	0	1	8	15	28	19	3	1	0	0	0	0	0	0	0	75
6:00 AM	0	1	0	2	4	34	72	19	6	1	0	0	0	0	0	0	0	139
7:00 AM	0	0	2	1	13	101	133	34	4	0	0	0	0	0	0	0	0	288
8:00 AM	0	1	0	0	21	101	146	36	1	0	1	0	0	0	0	0	0	307
9:00 AM	0	0	1	2	5	115	134	29	0	0	0	0	0	0	0	0	0	286
10:00 AM	0	0	3	2	11	102	159	40	4	0	1	0	0	0	0	0	0	322
11:00 AM	0	2	2	1	9	83	160	37	3	0	0	0	0	0	0	0	0	297
12:00 PM	0	1	1	4	11	115	182	39	3	2	0	0	0	0	0	0	0	358
1:00 PM	0	1	3	6	14	112	174	58	7	0	0	0	0	0	0	0	0	375
2:00 PM	0	1	3	2	18	121	193	52	4	3	0	0	0	0	0	0	0	397
3:00 PM	0	1	2	2	9	156	200	56	6	0	0	0	0	0	0	0	0	432
4:00 PM	1	1	1	3	12	119	234	59	5	1	0	0	0	0	0	0	0	436
5:00 PM	0	3	2	3	14	112	193	51	9	1	0	0	0	0	0	0	0	388
6:00 PM	0	2	2	4	4	77	157	49	10	0	0	0	0	0	0	0	0	305
7:00 PM	0	4	0	5	5	48	101	44	3	0	0	0	0	0	0	0	0	210
8:00 PM	0	1	1	2	10	46	92	26	8	3	1	0	0	0	0	0	0	190
9:00 PM	0	0	1	0	4	42	71	21	8	1	0	0	0	0	0	0	0	148
10:00 PM	0	0	0	0	0	13	39	19	5	0	0	0	0	0	0	0	0	76
11:00 PM	0	0	1	0	1	3	13	6	4	1	0	0	0	0	0	0	0	29
<b>Total</b>	<b>1</b>	<b>19</b>	<b>27</b>	<b>40</b>	<b>174</b>	<b>1,531</b>	<b>2,496</b>	<b>711</b>	<b>98</b>	<b>16</b>	<b>3</b>	<b>0</b>	<b>0</b>	<b>0</b>	<b>0</b>	<b>0</b>	<b>0</b>	<b>5,116</b>
<b>Percent</b>	<b>0.0%</b>	<b>0.4%</b>	<b>0.5%</b>	<b>0.8%</b>	<b>3.4%</b>	<b>29.9%</b>	<b>48.8%</b>	<b>13.9%</b>	<b>1.9%</b>	<b>0.3%</b>	<b>0.1%</b>	<b>0.0%</b>	<b>0.0%</b>	<b>0.0%</b>	<b>0.0%</b>	<b>0.0%</b>	<b>0.0%</b>	<b>0.0%</b>

Daily Percentile Speed Summary		Speed Statistics	
50th Percentile (Median)	36.2 mph	Mean (Average) Speed	36.3 mph
85th Percentile	40.3 mph	10 mph Pace	31.7 - 41.7 mph
95th Percentile	43.2 mph	Percent in Pace	81.24 %

Location: Old Redwood Highway, BTW Shiloh Rd & Lafayette Dr  
 Date Range: 7/28/2022 to 7/28/2022  
 Site Code: 02

**Total Study Average  
Northbound**

Time	Speed Range (mph)																	Total Volume
	0 - 10	10 - 15	15 - 20	20 - 25	25 - 30	30 - 35	35 - 40	40 - 45	45 - 50	50 - 55	55 - 60	60 - 65	65 - 70	70 - 75	75 - 80	80 - 85	85 +	
12:00 AM	0	0	1	0	0	3	3	1	2	1	0	0	0	0	0	0	0	11
1:00 AM	0	0	0	0	2	3	3	10	4	3	0	0	0	0	0	0	0	25
2:00 AM	0	0	0	1	1	2	2	1	1	1	0	0	0	0	0	0	0	9
3:00 AM	0	0	0	1	1	0	4	0	0	0	0	0	0	0	0	0	0	6
4:00 AM	0	0	0	0	0	6	7	3	2	0	0	0	0	0	0	0	0	18
5:00 AM	0	0	0	2	2	12	22	15	4	1	0	0	0	0	0	0	0	58
6:00 AM	0	0	0	0	7	26	36	22	6	3	0	0	0	0	0	0	0	100
7:00 AM	0	0	0	3	10	59	77	34	10	0	0	0	0	0	0	0	0	193
8:00 AM	0	1	1	3	18	66	89	36	10	2	0	0	0	0	0	0	0	226
9:00 AM	0	0	5	0	19	55	106	54	12	2	0	0	0	0	0	0	0	253
10:00 AM	0	0	3	15	40	101	101	34	10	2	0	0	0	0	0	0	0	306
11:00 AM	0	0	3	9	30	90	116	44	12	3	0	0	0	0	0	0	0	307
12:00 PM	0	0	3	9	44	111	108	54	5	1	0	0	0	0	0	0	0	335
1:00 PM	0	4	4	14	44	86	102	50	15	3	0	0	0	0	0	0	0	322
2:00 PM	1	1	3	7	46	95	96	53	25	5	0	0	0	0	0	0	0	332
3:00 PM	0	1	3	17	80	124	132	45	15	1	0	0	0	0	0	0	0	418
4:00 PM	3	8	30	37	72	125	122	65	12	4	0	0	0	0	0	0	0	478
5:00 PM	3	6	27	35	75	127	102	74	25	3	1	0	0	0	0	0	0	478
6:00 PM	0	0	3	8	21	77	121	57	17	2	0	0	0	0	0	0	0	306
7:00 PM	0	1	0	1	9	42	88	58	13	3	0	0	0	0	0	0	0	215
8:00 PM	0	0	1	5	14	58	53	31	12	2	0	1	0	0	0	0	0	177
9:00 PM	0	1	0	4	24	34	45	18	7	5	0	0	0	0	0	0	0	138
10:00 PM	0	0	1	1	1	14	22	21	8	2	0	0	0	0	0	0	0	70
11:00 PM	0	0	0	0	1	6	11	7	7	1	1	0	0	0	0	0	0	34
<b>Total</b>	<b>7</b>	<b>23</b>	<b>88</b>	<b>172</b>	<b>561</b>	<b>1,322</b>	<b>1,568</b>	<b>787</b>	<b>234</b>	<b>50</b>	<b>2</b>	<b>1</b>	<b>0</b>	<b>0</b>	<b>0</b>	<b>0</b>	<b>0</b>	<b>4,815</b>
<b>Percent</b>	<b>0.1%</b>	<b>0.5%</b>	<b>1.8%</b>	<b>3.6%</b>	<b>11.7%</b>	<b>27.5%</b>	<b>32.6%</b>	<b>16.3%</b>	<b>4.9%</b>	<b>1.0%</b>	<b>0.0%</b>	<b>0.0%</b>	<b>0.0%</b>	<b>0.0%</b>	<b>0.0%</b>	<b>0.0%</b>	<b>0.0%</b>	<b>0.0%</b>

Note: Average only considered on days with 24-hours of data.

Total Study Percentile Speed Summary		Total Study Speed Statistics	
50th Percentile (Median)	35.7 mph	Mean (Average) Speed	35.4 mph
85th Percentile	41.7 mph	10 mph Pace	30.9 - 40.9 mph
95th Percentile	45.6 mph	Percent in Pace	60.3 %

**Location:** Old Redwood Highway, BTW Shiloh Rd & Lafayette Dr  
**Date Range:** 7/28/2022 to 7/28/2022  
**Site Code:** 02

**Total Study Average**  
**Southbound**

Time	Speed Range (mph)																	Total Volume
	0 - 10	10 - 15	15 - 20	20 - 25	25 - 30	30 - 35	35 - 40	40 - 45	45 - 50	50 - 55	55 - 60	60 - 65	65 - 70	70 - 75	75 - 80	80 - 85	85 +	
12:00 AM	0	0	0	0	0	3	3	3	1	1	0	0	0	0	0	0	0	11
1:00 AM	0	0	0	0	1	3	1	5	0	0	0	0	0	0	0	0	0	10
2:00 AM	0	0	1	0	0	3	1	0	0	0	0	0	0	0	0	0	0	5
3:00 AM	0	0	0	0	0	2	2	3	2	0	0	0	0	0	0	0	0	9
4:00 AM	0	0	1	0	0	5	8	6	2	1	0	0	0	0	0	0	0	23
5:00 AM	0	0	0	1	8	15	28	19	3	1	0	0	0	0	0	0	0	75
6:00 AM	0	1	0	2	4	34	72	19	6	1	0	0	0	0	0	0	0	139
7:00 AM	0	0	2	1	13	101	133	34	4	0	0	0	0	0	0	0	0	288
8:00 AM	0	1	0	0	21	101	146	36	1	0	1	0	0	0	0	0	0	307
9:00 AM	0	0	1	2	5	115	134	29	0	0	0	0	0	0	0	0	0	286
10:00 AM	0	0	3	2	11	102	159	40	4	0	1	0	0	0	0	0	0	322
11:00 AM	0	2	2	1	9	83	160	37	3	0	0	0	0	0	0	0	0	297
12:00 PM	0	1	1	4	11	115	182	39	3	2	0	0	0	0	0	0	0	358
1:00 PM	0	1	3	6	14	112	174	58	7	0	0	0	0	0	0	0	0	375
2:00 PM	0	1	3	2	18	121	193	52	4	3	0	0	0	0	0	0	0	397
3:00 PM	0	1	2	2	9	156	200	56	6	0	0	0	0	0	0	0	0	432
4:00 PM	1	1	1	3	12	119	234	59	5	1	0	0	0	0	0	0	0	436
5:00 PM	0	3	2	3	14	112	193	51	9	1	0	0	0	0	0	0	0	388
6:00 PM	0	2	2	4	4	77	157	49	10	0	0	0	0	0	0	0	0	305
7:00 PM	0	4	0	5	5	48	101	44	3	0	0	0	0	0	0	0	0	210
8:00 PM	0	1	1	2	10	46	92	26	8	3	1	0	0	0	0	0	0	190
9:00 PM	0	0	1	0	4	42	71	21	8	1	0	0	0	0	0	0	0	148
10:00 PM	0	0	0	0	0	13	39	19	5	0	0	0	0	0	0	0	0	76
11:00 PM	0	0	1	0	1	3	13	6	4	1	0	0	0	0	0	0	0	29
<b>Total</b>	<b>1</b>	<b>19</b>	<b>27</b>	<b>40</b>	<b>174</b>	<b>1,531</b>	<b>2,496</b>	<b>711</b>	<b>98</b>	<b>16</b>	<b>3</b>	<b>0</b>	<b>0</b>	<b>0</b>	<b>0</b>	<b>0</b>	<b>0</b>	<b>5,116</b>
<b>Percent</b>	<b>0.0%</b>	<b>0.4%</b>	<b>0.5%</b>	<b>0.8%</b>	<b>3.4%</b>	<b>29.9%</b>	<b>48.8%</b>	<b>13.9%</b>	<b>1.9%</b>	<b>0.3%</b>	<b>0.1%</b>	<b>0.0%</b>	<b>0.0%</b>	<b>0.0%</b>	<b>0.0%</b>	<b>0.0%</b>	<b>0.0%</b>	<b>0.0%</b>

Note: Average only considered on days with 24-hours of data.

Total Study Percentile Speed Summary		Total Study Speed Statistics	
50th Percentile (Median)	36.2 mph	Mean (Average) Speed	36.3 mph
85th Percentile	40.3 mph	10 mph Pace	31.7 - 41.7 mph
95th Percentile	43.2 mph	Percent in Pace	81.2 %

Location: Old Redwood Highway, BTW Shiloh Rd & Lafayette Dr  
 Date Range: 7/28/2022 - 8/3/2022  
 Site Code: 02

Time	Thursday			Friday			Saturday			Sunday			Monday			Tuesday			Wednesday			Mid-Week Average		
	7/28/2022			7/29/2022			7/30/2022			7/31/2022			8/1/2022			8/2/2022			8/3/2022					
	NB	SB	Total	NB	SB	Total	NB	SB	Total	NB	SB	Total	NB	SB	Total	NB	SB	Total	NB	SB	Total	NB	SB	Total
12:00 AM	11	11	22	-	-	-	-	-	-	-	-	-	-	-	-	-	-	-	-	-	-	11	11	22
1:00 AM	25	10	35	-	-	-	-	-	-	-	-	-	-	-	-	-	-	-	-	-	-	25	10	35
2:00 AM	9	5	14	-	-	-	-	-	-	-	-	-	-	-	-	-	-	-	-	-	-	9	5	14
3:00 AM	6	9	15	-	-	-	-	-	-	-	-	-	-	-	-	-	-	-	-	-	-	6	9	15
4:00 AM	18	23	41	-	-	-	-	-	-	-	-	-	-	-	-	-	-	-	-	-	-	18	23	41
5:00 AM	58	75	133	-	-	-	-	-	-	-	-	-	-	-	-	-	-	-	-	-	-	58	75	133
6:00 AM	100	139	239	-	-	-	-	-	-	-	-	-	-	-	-	-	-	-	-	-	-	100	139	239
7:00 AM	193	288	481	-	-	-	-	-	-	-	-	-	-	-	-	-	-	-	-	-	-	193	288	481
8:00 AM	226	307	533	-	-	-	-	-	-	-	-	-	-	-	-	-	-	-	-	-	-	226	307	533
9:00 AM	253	286	539	-	-	-	-	-	-	-	-	-	-	-	-	-	-	-	-	-	-	253	286	539
10:00 AM	306	322	628	-	-	-	-	-	-	-	-	-	-	-	-	-	-	-	-	-	-	306	322	628
11:00 AM	307	297	604	-	-	-	-	-	-	-	-	-	-	-	-	-	-	-	-	-	-	307	297	604
12:00 PM	335	358	693	-	-	-	-	-	-	-	-	-	-	-	-	-	-	-	-	-	-	335	358	693
1:00 PM	322	375	697	-	-	-	-	-	-	-	-	-	-	-	-	-	-	-	-	-	-	322	375	697
2:00 PM	332	397	729	-	-	-	-	-	-	-	-	-	-	-	-	-	-	-	-	-	-	332	397	729
3:00 PM	418	432	850	-	-	-	-	-	-	-	-	-	-	-	-	-	-	-	-	-	-	418	432	850
4:00 PM	478	436	914	-	-	-	-	-	-	-	-	-	-	-	-	-	-	-	-	-	-	478	436	914
5:00 PM	478	388	866	-	-	-	-	-	-	-	-	-	-	-	-	-	-	-	-	-	-	478	388	866
6:00 PM	306	305	611	-	-	-	-	-	-	-	-	-	-	-	-	-	-	-	-	-	-	306	305	611
7:00 PM	215	210	425	-	-	-	-	-	-	-	-	-	-	-	-	-	-	-	-	-	-	215	210	425
8:00 PM	177	190	367	-	-	-	-	-	-	-	-	-	-	-	-	-	-	-	-	-	-	177	190	367
9:00 PM	138	148	286	-	-	-	-	-	-	-	-	-	-	-	-	-	-	-	-	-	-	138	148	286
10:00 PM	70	76	146	-	-	-	-	-	-	-	-	-	-	-	-	-	-	-	-	-	-	70	76	146
11:00 PM	34	29	63	-	-	-	-	-	-	-	-	-	-	-	-	-	-	-	-	-	-	34	29	63
Total	4,815	5,116	9,931	-	-	-	-	-	-	-	-	-	-	-	-	-	-	-	-	-	-	4,815	5,116	9,931
Percent	48%	52%	-	-	-	-	-	-	-	-	-	-	-	-	-	-	-	-	-	-	-	48%	52%	-
AM Peak	11:00	10:00	10:00	-	-	-	-	-	-	-	-	-	-	-	-	-	-	-	-	-	-	11:00	10:00	10:00
Vol.	307	322	628	-	-	-	-	-	-	-	-	-	-	-	-	-	-	-	-	-	-	307	322	628
PM Peak	16:00	16:00	16:00	-	-	-	-	-	-	-	-	-	-	-	-	-	-	-	-	-	-	16:00	16:00	16:00
Vol.	478	436	914	-	-	-	-	-	-	-	-	-	-	-	-	-	-	-	-	-	-	478	436	914

1. Mid-week average includes data between Tuesday and Thursday.

## Vehicle Classification Report Summary

**Location:** Shiloh Rd, BTW Conde Ln & US-101 Ramps  
**Count Direction:** Eastbound / Westbound  
**Date Range:** 7/28/2022 to 7/28/2022  
**Site Code:** 03

	FHWA Vehicle Classification													Total Volume
	1	2	3	4	5	6	7	8	9	10	11	12	13	
<b>Study Total</b>														
<b>Eastbound</b>	68	5,951	1,674	13	1,049	41	0	13	58	25	15	1	26	8,934
<b>Percent</b>	0.8%	66.6%	18.7%	0.1%	11.7%	0.5%	0.0%	0.1%	0.6%	0.3%	0.2%	0.0%	0.3%	100%
<b>Westbound</b>	78	5,542	1,585	8	1,268	33	0	15	56	8	3	0	5	8,601
<b>Percent</b>	0.9%	64.4%	18.4%	0.1%	14.7%	0.4%	0.0%	0.2%	0.7%	0.1%	0.0%	0.0%	0.1%	100%
<b>Total</b>	146	11,493	3,259	21	2,317	74	0	28	114	33	18	1	31	17,535
<b>Percent</b>	0.8%	65.5%	18.6%	0.1%	13.2%	0.4%	0.0%	0.2%	0.7%	0.2%	0.1%	0.0%	0.2%	100%

<b>FHWA Vehicle Classification</b>	
Class 1 - Motorcycles	Class 8 - Four or Fewer Axle Single-Trailer Trucks
Class 2 - Passenger Cars	Class 9 - Five-Axle Single-Trailer Trucks
Class 3 - Other Two-Axle, Four-Tire Single Unit Vehicles	Class 10 - Six or More Axle Single-Trailer Trucks
Class 4 - Buses	Class 11 - Five or fewer Axle Multi-Trailer Trucks
Class 5 - Two-Axle, Six-Tire, Single-Unit Trucks	Class 12 - Six-Axle Multi-Trailer Trucks
Class 6 - Three-Axle Single-Unit Trucks	Class 13 - Seven or More Axle Multi-Trailer Trucks
Class 7 - Four or More Axle Single-Unit Trucks	

**Location:** Shiloh Rd, BTW Conde Ln & US-101 Ramps  
**Date Range:** 7/28/2022 to 7/28/2022  
**Site Code:** 03

**Thursday, July 28, 2022**  
**Eastbound**

Time	FHWA Vehicle Classification													Total Volume
	1	2	3	4	5	6	7	8	9	10	11	12	13	
12:00 AM	0	25	7	0	2	1	0	0	0	0	0	0	0	35
1:00 AM	0	21	5	0	1	0	0	0	0	0	0	0	1	28
2:00 AM	0	9	1	0	2	0	0	0	1	0	0	0	0	13
3:00 AM	0	16	0	0	4	0	0	0	3	0	0	0	0	23
4:00 AM	0	28	13	0	10	0	0	0	1	0	0	0	0	52
5:00 AM	0	80	39	0	32	0	0	0	5	1	0	0	0	157
6:00 AM	3	157	68	1	44	3	0	1	7	0	0	0	1	285
7:00 AM	1	292	98	0	73	2	0	0	6	1	1	0	3	477
8:00 AM	7	344	102	0	69	1	0	0	4	3	2	0	3	535
9:00 AM	2	323	104	0	60	4	0	0	6	4	3	0	1	507
10:00 AM	6	323	102	0	81	4	0	4	1	1	0	0	3	525
11:00 AM	2	400	121	1	79	4	0	0	5	1	2	1	3	619
12:00 PM	9	386	122	2	75	3	0	2	2	4	1	0	1	607
1:00 PM	6	379	123	2	70	5	0	1	2	2	0	0	1	591
2:00 PM	7	454	104	0	89	2	0	1	7	1	0	0	2	667
3:00 PM	8	463	159	0	74	2	0	3	4	3	3	0	3	722
4:00 PM	4	588	153	0	82	4	0	0	2	2	3	0	2	840
5:00 PM	4	443	96	1	56	3	0	1	1	1	0	0	2	608
6:00 PM	4	361	81	0	42	1	0	0	0	0	0	0	0	489
7:00 PM	3	285	63	2	38	1	0	0	0	0	0	0	0	392
8:00 PM	0	220	46	1	33	1	0	0	0	1	0	0	0	302
9:00 PM	1	181	38	0	17	0	0	0	0	0	0	0	0	237
10:00 PM	1	120	17	2	11	0	0	0	1	0	0	0	0	152
11:00 PM	0	53	12	1	5	0	0	0	0	0	0	0	0	71
<b>Total</b>	<b>68</b>	<b>5,951</b>	<b>1,674</b>	<b>13</b>	<b>1,049</b>	<b>41</b>	<b>0</b>	<b>13</b>	<b>58</b>	<b>25</b>	<b>15</b>	<b>1</b>	<b>26</b>	<b>8,934</b>
<b>Percent</b>	<b>0.8%</b>	<b>66.6%</b>	<b>18.7%</b>	<b>0.1%</b>	<b>11.7%</b>	<b>0.5%</b>	<b>0.0%</b>	<b>0.1%</b>	<b>0.6%</b>	<b>0.3%</b>	<b>0.2%</b>	<b>0.0%</b>	<b>0.3%</b>	

**Location:** Shiloh Rd, BTW Conde Ln & US-101 Ramps  
**Date Range:** 7/28/2022 to 7/28/2022  
**Site Code:** 03

**Thursday, July 28, 2022**  
**Westbound**

Time	FHWA Vehicle Classification													Total Volume
	1	2	3	4	5	6	7	8	9	10	11	12	13	
12:00 AM	0	22	3	0	5	0	0	0	1	0	0	0	0	31
1:00 AM	0	21	5	0	1	0	0	0	0	0	0	0	0	27
2:00 AM	0	11	3	0	4	0	0	0	0	0	0	0	0	18
3:00 AM	0	19	6	0	1	0	0	0	1	0	0	0	0	27
4:00 AM	0	37	5	0	9	0	0	0	2	0	1	0	0	54
5:00 AM	2	116	38	0	36	0	0	1	4	0	0	0	0	197
6:00 AM	7	299	96	0	77	0	0	1	4	0	0	0	1	485
7:00 AM	8	303	97	0	84	3	0	0	4	2	0	0	0	501
8:00 AM	7	377	97	0	73	2	0	1	5	2	0	0	0	564
9:00 AM	4	245	90	2	82	4	0	1	6	1	0	0	0	435
10:00 AM	8	242	90	1	83	3	0	0	2	0	0	0	0	429
11:00 AM	4	313	87	1	94	7	0	3	7	0	0	0	2	518
12:00 PM	3	366	135	0	97	1	0	2	2	1	1	0	0	608
1:00 PM	5	399	99	1	93	5	0	2	5	0	1	0	2	612
2:00 PM	4	356	109	0	103	0	0	1	5	0	0	0	0	578
3:00 PM	3	410	116	2	89	3	0	1	3	0	0	0	0	627
4:00 PM	5	425	113	0	101	1	0	1	3	1	0	0	0	650
5:00 PM	6	525	126	0	89	1	0	0	0	1	0	0	0	748
6:00 PM	6	312	87	1	47	0	0	0	2	0	0	0	0	455
7:00 PM	1	249	86	0	29	1	0	0	0	0	0	0	0	366
8:00 PM	0	188	39	0	34	1	0	0	0	0	0	0	0	262
9:00 PM	2	143	32	0	16	1	0	0	0	0	0	0	0	194
10:00 PM	2	109	14	0	16	0	0	0	0	0	0	0	0	141
11:00 PM	1	55	12	0	5	0	0	1	0	0	0	0	0	74
<b>Total</b>	<b>78</b>	<b>5,542</b>	<b>1,585</b>	<b>8</b>	<b>1,268</b>	<b>33</b>	<b>0</b>	<b>15</b>	<b>56</b>	<b>8</b>	<b>3</b>	<b>0</b>	<b>5</b>	<b>8,601</b>
<b>Percent</b>	<b>0.9%</b>	<b>64.4%</b>	<b>18.4%</b>	<b>0.1%</b>	<b>14.7%</b>	<b>0.4%</b>	<b>0.0%</b>	<b>0.2%</b>	<b>0.7%</b>	<b>0.1%</b>	<b>0.0%</b>	<b>0.0%</b>	<b>0.1%</b>	

**Location:** Shiloh Rd, BTW Conde Ln & US-101 Ramps  
**Date Range:** 7/28/2022 to 7/28/2022  
**Site Code:** 03

**Total Study Average  
Eastbound**

Time	FHWA Vehicle Classification													Total Volume
	1	2	3	4	5	6	7	8	9	10	11	12	13	
12:00 AM	0	25	7	0	2	1	0	0	0	0	0	0	0	35
1:00 AM	0	21	5	0	1	0	0	0	0	0	0	0	1	28
2:00 AM	0	9	1	0	2	0	0	0	1	0	0	0	0	13
3:00 AM	0	16	0	0	4	0	0	0	3	0	0	0	0	23
4:00 AM	0	28	13	0	10	0	0	0	1	0	0	0	0	52
5:00 AM	0	80	39	0	32	0	0	0	5	1	0	0	0	157
6:00 AM	3	157	68	1	44	3	0	1	7	0	0	0	1	285
7:00 AM	1	292	98	0	73	2	0	0	6	1	1	0	3	477
8:00 AM	7	344	102	0	69	1	0	0	4	3	2	0	3	535
9:00 AM	2	323	104	0	60	4	0	0	6	4	3	0	1	507
10:00 AM	6	323	102	0	81	4	0	4	1	1	0	0	3	525
11:00 AM	2	400	121	1	79	4	0	0	5	1	2	1	3	619
12:00 PM	9	386	122	2	75	3	0	2	2	4	1	0	1	607
1:00 PM	6	379	123	2	70	5	0	1	2	2	0	0	1	591
2:00 PM	7	454	104	0	89	2	0	1	7	1	0	0	2	667
3:00 PM	8	463	159	0	74	2	0	3	4	3	3	0	3	722
4:00 PM	4	588	153	0	82	4	0	0	2	2	3	0	2	840
5:00 PM	4	443	96	1	56	3	0	1	1	1	0	0	2	608
6:00 PM	4	361	81	0	42	1	0	0	0	0	0	0	0	489
7:00 PM	3	285	63	2	38	1	0	0	0	0	0	0	0	392
8:00 PM	0	220	46	1	33	1	0	0	0	1	0	0	0	302
9:00 PM	1	181	38	0	17	0	0	0	0	0	0	0	0	237
10:00 PM	1	120	17	2	11	0	0	0	1	0	0	0	0	152
11:00 PM	0	53	12	1	5	0	0	0	0	0	0	0	0	71
<b>Total</b>	<b>68</b>	<b>5,951</b>	<b>1,674</b>	<b>13</b>	<b>1,049</b>	<b>41</b>	<b>0</b>	<b>13</b>	<b>58</b>	<b>25</b>	<b>15</b>	<b>1</b>	<b>26</b>	<b>8,934</b>
<b>Percent</b>	<b>0.8%</b>	<b>66.6%</b>	<b>18.7%</b>	<b>0.1%</b>	<b>11.7%</b>	<b>0.5%</b>	<b>0.0%</b>	<b>0.1%</b>	<b>0.6%</b>	<b>0.3%</b>	<b>0.2%</b>	<b>0.0%</b>	<b>0.3%</b>	

Note: Average only considered on days with 24-hours of data.



**Location:** Shiloh Rd, BTW Conde Ln & US-101 Ramps  
**Date Range:** 7/28/2022 to 7/28/2022  
**Site Code:** 03

**Total Study Average  
Westbound**

Time	FHWA Vehicle Classification													Total Volume
	1	2	3	4	5	6	7	8	9	10	11	12	13	
12:00 AM	0	22	3	0	5	0	0	0	1	0	0	0	0	31
1:00 AM	0	21	5	0	1	0	0	0	0	0	0	0	0	27
2:00 AM	0	11	3	0	4	0	0	0	0	0	0	0	0	18
3:00 AM	0	19	6	0	1	0	0	0	1	0	0	0	0	27
4:00 AM	0	37	5	0	9	0	0	0	2	0	1	0	0	54
5:00 AM	2	116	38	0	36	0	0	1	4	0	0	0	0	197
6:00 AM	7	299	96	0	77	0	0	1	4	0	0	0	1	485
7:00 AM	8	303	97	0	84	3	0	0	4	2	0	0	0	501
8:00 AM	7	377	97	0	73	2	0	1	5	2	0	0	0	564
9:00 AM	4	245	90	2	82	4	0	1	6	1	0	0	0	435
10:00 AM	8	242	90	1	83	3	0	0	2	0	0	0	0	429
11:00 AM	4	313	87	1	94	7	0	3	7	0	0	0	2	518
12:00 PM	3	366	135	0	97	1	0	2	2	1	1	0	0	608
1:00 PM	5	399	99	1	93	5	0	2	5	0	1	0	2	612
2:00 PM	4	356	109	0	103	0	0	1	5	0	0	0	0	578
3:00 PM	3	410	116	2	89	3	0	1	3	0	0	0	0	627
4:00 PM	5	425	113	0	101	1	0	1	3	1	0	0	0	650
5:00 PM	6	525	126	0	89	1	0	0	0	1	0	0	0	748
6:00 PM	6	312	87	1	47	0	0	0	2	0	0	0	0	455
7:00 PM	1	249	86	0	29	1	0	0	0	0	0	0	0	366
8:00 PM	0	188	39	0	34	1	0	0	0	0	0	0	0	262
9:00 PM	2	143	32	0	16	1	0	0	0	0	0	0	0	194
10:00 PM	2	109	14	0	16	0	0	0	0	0	0	0	0	141
11:00 PM	1	55	12	0	5	0	0	1	0	0	0	0	0	74
<b>Total</b>	<b>78</b>	<b>5,542</b>	<b>1,585</b>	<b>8</b>	<b>1,268</b>	<b>33</b>	<b>0</b>	<b>15</b>	<b>56</b>	<b>8</b>	<b>3</b>	<b>0</b>	<b>5</b>	<b>8,601</b>
<b>Percent</b>	<b>0.9%</b>	<b>64.4%</b>	<b>18.4%</b>	<b>0.1%</b>	<b>14.7%</b>	<b>0.4%</b>	<b>0.0%</b>	<b>0.2%</b>	<b>0.7%</b>	<b>0.1%</b>	<b>0.0%</b>	<b>0.0%</b>	<b>0.1%</b>	

Note: Average only considered on days with 24-hours of data.

**Location:** Shiloh Rd, BTW Conde Ln & US-101 Ramps  
**Date Range:** 7/28/2022 to 7/28/2022  
**Site Code:** 03

**3-Day (Tuesday - Thursday) Average  
 Eastbound**

Time	FHWA Vehicle Classification													Total Volume
	1	2	3	4	5	6	7	8	9	10	11	12	13	
12:00 AM	0	25	7	0	2	1	0	0	0	0	0	0	0	35
1:00 AM	0	21	5	0	1	0	0	0	0	0	0	0	1	28
2:00 AM	0	9	1	0	2	0	0	0	1	0	0	0	0	13
3:00 AM	0	16	0	0	4	0	0	0	3	0	0	0	0	23
4:00 AM	0	28	13	0	10	0	0	0	1	0	0	0	0	52
5:00 AM	0	80	39	0	32	0	0	0	5	1	0	0	0	157
6:00 AM	3	157	68	1	44	3	0	1	7	0	0	0	1	285
7:00 AM	1	292	98	0	73	2	0	0	6	1	1	0	3	477
8:00 AM	7	344	102	0	69	1	0	0	4	3	2	0	3	535
9:00 AM	2	323	104	0	60	4	0	0	6	4	3	0	1	507
10:00 AM	6	323	102	0	81	4	0	4	1	1	0	0	3	525
11:00 AM	2	400	121	1	79	4	0	0	5	1	2	1	3	619
12:00 PM	9	386	122	2	75	3	0	2	2	4	1	0	1	607
1:00 PM	6	379	123	2	70	5	0	1	2	2	0	0	1	591
2:00 PM	7	454	104	0	89	2	0	1	7	1	0	0	2	667
3:00 PM	8	463	159	0	74	2	0	3	4	3	3	0	3	722
4:00 PM	4	588	153	0	82	4	0	0	2	2	3	0	2	840
5:00 PM	4	443	96	1	56	3	0	1	1	1	0	0	2	608
6:00 PM	4	361	81	0	42	1	0	0	0	0	0	0	0	489
7:00 PM	3	285	63	2	38	1	0	0	0	0	0	0	0	392
8:00 PM	0	220	46	1	33	1	0	0	0	1	0	0	0	302
9:00 PM	1	181	38	0	17	0	0	0	0	0	0	0	0	237
10:00 PM	1	120	17	2	11	0	0	0	1	0	0	0	0	152
11:00 PM	0	53	12	1	5	0	0	0	0	0	0	0	0	71
<b>Total</b>	<b>68</b>	<b>5,951</b>	<b>1,674</b>	<b>13</b>	<b>1,049</b>	<b>41</b>	<b>0</b>	<b>13</b>	<b>58</b>	<b>25</b>	<b>15</b>	<b>1</b>	<b>26</b>	<b>8,934</b>
<b>Percent</b>	<b>0.8%</b>	<b>66.6%</b>	<b>18.7%</b>	<b>0.1%</b>	<b>11.7%</b>	<b>0.5%</b>	<b>0.0%</b>	<b>0.1%</b>	<b>0.6%</b>	<b>0.3%</b>	<b>0.2%</b>	<b>0.0%</b>	<b>0.3%</b>	

**Location:** Shiloh Rd, BTW Conde Ln & US-101 Ramps  
**Date Range:** 7/28/2022 to 7/28/2022  
**Site Code:** 03

**3-Day (Tuesday - Thursday) Average  
 Westbound**

Time	FHWA Vehicle Classification													Total Volume
	1	2	3	4	5	6	7	8	9	10	11	12	13	
12:00 AM	0	22	3	0	5	0	0	0	1	0	0	0	0	31
1:00 AM	0	21	5	0	1	0	0	0	0	0	0	0	0	27
2:00 AM	0	11	3	0	4	0	0	0	0	0	0	0	0	18
3:00 AM	0	19	6	0	1	0	0	0	1	0	0	0	0	27
4:00 AM	0	37	5	0	9	0	0	0	2	0	1	0	0	54
5:00 AM	2	116	38	0	36	0	0	1	4	0	0	0	0	197
6:00 AM	7	299	96	0	77	0	0	1	4	0	0	0	1	485
7:00 AM	8	303	97	0	84	3	0	0	4	2	0	0	0	501
8:00 AM	7	377	97	0	73	2	0	1	5	2	0	0	0	564
9:00 AM	4	245	90	2	82	4	0	1	6	1	0	0	0	435
10:00 AM	8	242	90	1	83	3	0	0	2	0	0	0	0	429
11:00 AM	4	313	87	1	94	7	0	3	7	0	0	0	2	518
12:00 PM	3	366	135	0	97	1	0	2	2	1	1	0	0	608
1:00 PM	5	399	99	1	93	5	0	2	5	0	1	0	2	612
2:00 PM	4	356	109	0	103	0	0	1	5	0	0	0	0	578
3:00 PM	3	410	116	2	89	3	0	1	3	0	0	0	0	627
4:00 PM	5	425	113	0	101	1	0	1	3	1	0	0	0	650
5:00 PM	6	525	126	0	89	1	0	0	0	1	0	0	0	748
6:00 PM	6	312	87	1	47	0	0	0	2	0	0	0	0	455
7:00 PM	1	249	86	0	29	1	0	0	0	0	0	0	0	366
8:00 PM	0	188	39	0	34	1	0	0	0	0	0	0	0	262
9:00 PM	2	143	32	0	16	1	0	0	0	0	0	0	0	194
10:00 PM	2	109	14	0	16	0	0	0	0	0	0	0	0	141
11:00 PM	1	55	12	0	5	0	0	1	0	0	0	0	0	74
<b>Total</b>	<b>78</b>	<b>5,542</b>	<b>1,585</b>	<b>8</b>	<b>1,268</b>	<b>33</b>	<b>0</b>	<b>15</b>	<b>56</b>	<b>8</b>	<b>3</b>	<b>0</b>	<b>5</b>	<b>8,601</b>
<b>Percent</b>	<b>0.9%</b>	<b>64.4%</b>	<b>18.4%</b>	<b>0.1%</b>	<b>14.7%</b>	<b>0.4%</b>	<b>0.0%</b>	<b>0.2%</b>	<b>0.7%</b>	<b>0.1%</b>	<b>0.0%</b>	<b>0.0%</b>	<b>0.1%</b>	

## Vehicle Speed Report Summary

**Location:** Shiloh Rd, BTW Conde Ln & US-101 Ramps  
**Count Direction:** Eastbound / Westbound  
**Date Range:** 7/28/2022 to 7/28/2022  
**Site Code:** 03

	Speed Range (mph)																	Total Volume
	0 - 10	10 - 15	15 - 20	20 - 25	25 - 30	30 - 35	35 - 40	40 - 45	45 - 50	50 - 55	55 - 60	60 - 65	65 - 70	70 - 75	75 - 80	80 - 85	85 +	
<b>Study Total</b>																		
<b>Eastbound</b>	1	2	17	49	320	1,659	3,547	2,376	772	143	37	6	5	0	0	0	0	8,934
<b>Percent</b>	0.0%	0.0%	0.2%	0.5%	3.6%	18.6%	39.7%	26.6%	8.6%	1.6%	0.4%	0.1%	0.1%	0.0%	0.0%	0.0%	0.0%	100%
<b>Westbound</b>	2	10	29	87	465	1,500	3,078	2,486	761	149	28	5	1	0	0	0	0	8,601
<b>Percent</b>	0.0%	0.1%	0.3%	1.0%	5.4%	17.4%	35.8%	28.9%	8.8%	1.7%	0.3%	0.1%	0.0%	0.0%	0.0%	0.0%	0.0%	100%
<b>Total</b>	3	12	46	136	785	3,159	6,625	4,862	1,533	292	65	11	6	0	0	0	0	17,535
<b>Percent</b>	0.0%	0.1%	0.3%	0.8%	4.5%	18.0%	37.8%	27.7%	8.7%	1.7%	0.4%	0.1%	0.0%	0.0%	0.0%	0.0%	0.0%	100%

Total Study Percentile Speed Summary			Total Study Speed Statistics		
<b>Eastbound</b>			<b>Eastbound</b>		
50th Percentile (Median)	38.4	mph	Mean (Average) Speed	38.6	mph
85th Percentile	43.8	mph	10 mph Pace	33.7 - 43.7	mph
95th Percentile	47.4	mph	Percent in Pace	68.8	%
<b>Westbound</b>			<b>Westbound</b>		
50th Percentile (Median)	38.7	mph	Mean (Average) Speed	38.5	mph
85th Percentile	44.0	mph	10 mph Pace	33.9 - 43.9	mph
95th Percentile	47.4	mph	Percent in Pace	65.8	%

Location: Shiloh Rd, BTW Conde Ln & US-101 Ramps  
 Date Range: 7/28/2022 to 7/28/2022  
 Site Code: 03

Thursday, July 28, 2022  
 Eastbound

Time	Speed Range (mph)																	Total Volume
	0 - 10	10 - 15	15 - 20	20 - 25	25 - 30	30 - 35	35 - 40	40 - 45	45 - 50	50 - 55	55 - 60	60 - 65	65 - 70	70 - 75	75 - 80	80 - 85	85 +	
12:00 AM	0	0	0	1	1	8	10	7	7	1	0	0	0	0	0	0	0	35
1:00 AM	0	0	2	1	0	2	10	7	4	2	0	0	0	0	0	0	0	28
2:00 AM	0	0	0	0	0	3	3	2	3	2	0	0	0	0	0	0	0	13
3:00 AM	0	0	0	0	0	1	9	8	2	3	0	0	0	0	0	0	0	23
4:00 AM	0	0	0	1	0	4	12	16	13	3	2	0	1	0	0	0	0	52
5:00 AM	0	0	0	0	3	15	44	55	33	5	0	2	0	0	0	0	0	157
6:00 AM	0	0	0	3	12	53	95	71	38	11	2	0	0	0	0	0	0	285
7:00 AM	0	0	1	1	15	77	175	141	53	12	2	0	0	0	0	0	0	477
8:00 AM	1	0	1	8	18	104	200	147	49	7	0	0	0	0	0	0	0	535
9:00 AM	0	0	3	9	18	105	197	129	35	7	4	0	0	0	0	0	0	507
10:00 AM	0	1	0	1	19	119	215	124	40	5	1	0	0	0	0	0	0	525
11:00 AM	0	0	0	3	28	140	251	158	33	4	2	0	0	0	0	0	0	619
12:00 PM	0	0	4	7	36	155	222	135	42	4	1	1	0	0	0	0	0	607
1:00 PM	0	0	0	6	28	137	238	134	41	6	1	0	0	0	0	0	0	591
2:00 PM	0	1	4	3	31	137	295	140	48	5	2	0	1	0	0	0	0	667
3:00 PM	0	0	1	1	32	175	317	149	37	4	5	0	1	0	0	0	0	722
4:00 PM	0	0	1	2	30	153	349	238	55	8	4	0	0	0	0	0	0	840
5:00 PM	0	0	0	0	8	57	264	192	75	9	1	2	0	0	0	0	0	608
6:00 PM	0	0	0	0	4	39	187	180	57	17	4	0	1	0	0	0	0	489
7:00 PM	0	0	0	0	12	48	159	117	41	12	3	0	0	0	0	0	0	392
8:00 PM	0	0	0	2	9	62	111	86	25	7	0	0	0	0	0	0	0	302
9:00 PM	0	0	0	0	10	23	107	70	24	2	1	0	0	0	0	0	0	237
10:00 PM	0	0	0	0	5	28	61	48	5	3	1	0	1	0	0	0	0	152
11:00 PM	0	0	0	0	1	14	16	22	12	4	1	1	0	0	0	0	0	71
<b>Total</b>	<b>1</b>	<b>2</b>	<b>17</b>	<b>49</b>	<b>320</b>	<b>1,659</b>	<b>3,547</b>	<b>2,376</b>	<b>772</b>	<b>143</b>	<b>37</b>	<b>6</b>	<b>5</b>	<b>0</b>	<b>0</b>	<b>0</b>	<b>0</b>	<b>8,934</b>
<b>Percent</b>	<b>0.0%</b>	<b>0.0%</b>	<b>0.2%</b>	<b>0.5%</b>	<b>3.6%</b>	<b>18.6%</b>	<b>39.7%</b>	<b>26.6%</b>	<b>8.6%</b>	<b>1.6%</b>	<b>0.4%</b>	<b>0.1%</b>	<b>0.1%</b>	<b>0.0%</b>	<b>0.0%</b>	<b>0.0%</b>	<b>0.0%</b>	

Daily Percentile Speed Summary		Speed Statistics	
50th Percentile (Median)	38.4 mph	Mean (Average) Speed	38.6 mph
85th Percentile	43.8 mph	10 mph Pace	33.7 - 43.7 mph
95th Percentile	47.4 mph	Percent in Pace	68.8 %

Location: Shiloh Rd, BTW Conde Ln & US-101 Ramps  
 Date Range: 7/28/2022 to 7/28/2022  
 Site Code: 03

Thursday, July 28, 2022  
 Westbound

Time	Speed Range (mph)																	Total Volume
	0 - 10	10 - 15	15 - 20	20 - 25	25 - 30	30 - 35	35 - 40	40 - 45	45 - 50	50 - 55	55 - 60	60 - 65	65 - 70	70 - 75	75 - 80	80 - 85	85 +	
12:00 AM	0	0	0	0	3	3	11	7	6	0	0	0	1	0	0	0	0	31
1:00 AM	0	0	0	0	0	2	5	7	7	4	1	1	0	0	0	0	0	27
2:00 AM	0	0	0	0	1	0	4	7	3	3	0	0	0	0	0	0	0	18
3:00 AM	0	0	0	0	1	0	5	12	6	3	0	0	0	0	0	0	0	27
4:00 AM	0	0	0	0	0	1	14	25	9	5	0	0	0	0	0	0	0	54
5:00 AM	0	0	0	0	2	13	50	90	34	7	1	0	0	0	0	0	0	197
6:00 AM	0	1	2	1	13	48	158	168	74	17	3	0	0	0	0	0	0	485
7:00 AM	0	5	3	3	25	85	160	146	59	11	3	1	0	0	0	0	0	501
8:00 AM	0	0	0	4	26	86	191	189	60	7	1	0	0	0	0	0	0	564
9:00 AM	0	0	0	2	21	53	162	159	31	5	2	0	0	0	0	0	0	435
10:00 AM	0	0	0	2	28	79	163	122	31	3	1	0	0	0	0	0	0	429
11:00 AM	0	0	1	13	28	102	195	138	36	3	2	0	0	0	0	0	0	518
12:00 PM	0	0	0	4	64	144	231	135	23	7	0	0	0	0	0	0	0	608
1:00 PM	1	2	9	10	42	148	207	150	38	3	2	0	0	0	0	0	0	612
2:00 PM	0	0	1	4	37	124	248	125	28	10	0	1	0	0	0	0	0	578
3:00 PM	0	0	3	10	63	151	217	146	34	3	0	0	0	0	0	0	0	627
4:00 PM	0	0	3	10	38	136	250	155	44	11	3	0	0	0	0	0	0	650
5:00 PM	1	2	7	22	52	137	276	199	46	6	0	0	0	0	0	0	0	748
6:00 PM	0	0	0	1	6	73	180	136	45	10	3	1	0	0	0	0	0	455
7:00 PM	0	0	0	0	3	35	126	147	46	8	1	0	0	0	0	0	0	366
8:00 PM	0	0	0	0	2	29	99	90	34	7	1	0	0	0	0	0	0	262
9:00 PM	0	0	0	0	5	32	65	62	25	5	0	0	0	0	0	0	0	194
10:00 PM	0	0	0	0	3	15	44	46	28	4	1	0	0	0	0	0	0	141
11:00 PM	0	0	0	1	2	4	17	25	14	7	3	1	0	0	0	0	0	74
<b>Total</b>	<b>2</b>	<b>10</b>	<b>29</b>	<b>87</b>	<b>465</b>	<b>1,500</b>	<b>3,078</b>	<b>2,486</b>	<b>761</b>	<b>149</b>	<b>28</b>	<b>5</b>	<b>1</b>	<b>0</b>	<b>0</b>	<b>0</b>	<b>0</b>	<b>8,601</b>
<b>Percent</b>	<b>0.0%</b>	<b>0.1%</b>	<b>0.3%</b>	<b>1.0%</b>	<b>5.4%</b>	<b>17.4%</b>	<b>35.8%</b>	<b>28.9%</b>	<b>8.8%</b>	<b>1.7%</b>	<b>0.3%</b>	<b>0.1%</b>	<b>0.0%</b>	<b>0.0%</b>	<b>0.0%</b>	<b>0.0%</b>	<b>0.0%</b>	<b>0.0%</b>

Daily Percentile Speed Summary		Speed Statistics	
50th Percentile (Median)	38.7 mph	Mean (Average) Speed	38.5 mph
85th Percentile	44.0 mph	10 mph Pace	33.9 - 43.9 mph
95th Percentile	47.4 mph	Percent in Pace	65.79 %

**Location:** Shiloh Rd, BTW Conde Ln & US-101 Ramps  
**Date Range:** 7/28/2022 to 7/28/2022  
**Site Code:** 03

**Total Study Average  
Eastbound**

Time	Speed Range (mph)																	Total Volume
	0 - 10	10 - 15	15 - 20	20 - 25	25 - 30	30 - 35	35 - 40	40 - 45	45 - 50	50 - 55	55 - 60	60 - 65	65 - 70	70 - 75	75 - 80	80 - 85	85 +	
12:00 AM	0	0	0	1	1	8	10	7	7	1	0	0	0	0	0	0	0	35
1:00 AM	0	0	2	1	0	2	10	7	4	2	0	0	0	0	0	0	0	28
2:00 AM	0	0	0	0	0	3	3	2	3	2	0	0	0	0	0	0	0	13
3:00 AM	0	0	0	0	0	1	9	8	2	3	0	0	0	0	0	0	0	23
4:00 AM	0	0	0	1	0	4	12	16	13	3	2	0	1	0	0	0	0	52
5:00 AM	0	0	0	0	3	15	44	55	33	5	0	2	0	0	0	0	0	157
6:00 AM	0	0	0	3	12	53	95	71	38	11	2	0	0	0	0	0	0	285
7:00 AM	0	0	1	1	15	77	175	141	53	12	2	0	0	0	0	0	0	477
8:00 AM	1	0	1	8	18	104	200	147	49	7	0	0	0	0	0	0	0	535
9:00 AM	0	0	3	9	18	105	197	129	35	7	4	0	0	0	0	0	0	507
10:00 AM	0	1	0	1	19	119	215	124	40	5	1	0	0	0	0	0	0	525
11:00 AM	0	0	0	3	28	140	251	158	33	4	2	0	0	0	0	0	0	619
12:00 PM	0	0	4	7	36	155	222	135	42	4	1	1	0	0	0	0	0	607
1:00 PM	0	0	0	6	28	137	238	134	41	6	1	0	0	0	0	0	0	591
2:00 PM	0	1	4	3	31	137	295	140	48	5	2	0	1	0	0	0	0	667
3:00 PM	0	0	1	1	32	175	317	149	37	4	5	0	1	0	0	0	0	722
4:00 PM	0	0	1	2	30	153	349	238	55	8	4	0	0	0	0	0	0	840
5:00 PM	0	0	0	0	8	57	264	192	75	9	1	2	0	0	0	0	0	608
6:00 PM	0	0	0	0	4	39	187	180	57	17	4	0	1	0	0	0	0	489
7:00 PM	0	0	0	0	12	48	159	117	41	12	3	0	0	0	0	0	0	392
8:00 PM	0	0	0	2	9	62	111	86	25	7	0	0	0	0	0	0	0	302
9:00 PM	0	0	0	0	10	23	107	70	24	2	1	0	0	0	0	0	0	237
10:00 PM	0	0	0	0	5	28	61	48	5	3	1	0	1	0	0	0	0	152
11:00 PM	0	0	0	0	1	14	16	22	12	4	1	1	0	0	0	0	0	71
<b>Total</b>	<b>1</b>	<b>2</b>	<b>17</b>	<b>49</b>	<b>320</b>	<b>1,659</b>	<b>3,547</b>	<b>2,376</b>	<b>772</b>	<b>143</b>	<b>37</b>	<b>6</b>	<b>5</b>	<b>0</b>	<b>0</b>	<b>0</b>	<b>0</b>	<b>8,934</b>
<b>Percent</b>	<b>0.0%</b>	<b>0.0%</b>	<b>0.2%</b>	<b>0.5%</b>	<b>3.6%</b>	<b>18.6%</b>	<b>39.7%</b>	<b>26.6%</b>	<b>8.6%</b>	<b>1.6%</b>	<b>0.4%</b>	<b>0.1%</b>	<b>0.1%</b>	<b>0.0%</b>	<b>0.0%</b>	<b>0.0%</b>	<b>0.0%</b>	

Note: Average only considered on days with 24-hours of data.

Total Study Percentile Speed Summary		Total Study Speed Statistics	
50th Percentile (Median)	38.4 mph	Mean (Average) Speed	38.6 mph
85th Percentile	43.8 mph	10 mph Pace	33.7 - 43.7 mph
95th Percentile	47.4 mph	Percent in Pace	68.8 %

Location: Shiloh Rd, BTW Conde Ln & US-101 Ramps  
 Date Range: 7/28/2022 to 7/28/2022  
 Site Code: 03

**Total Study Average  
 Westbound**

Time	Speed Range (mph)																	Total Volume
	0 - 10	10 - 15	15 - 20	20 - 25	25 - 30	30 - 35	35 - 40	40 - 45	45 - 50	50 - 55	55 - 60	60 - 65	65 - 70	70 - 75	75 - 80	80 - 85	85 +	
12:00 AM	0	0	0	0	3	3	11	7	6	0	0	0	1	0	0	0	0	31
1:00 AM	0	0	0	0	0	2	5	7	7	4	1	1	0	0	0	0	0	27
2:00 AM	0	0	0	0	1	0	4	7	3	3	0	0	0	0	0	0	0	18
3:00 AM	0	0	0	0	1	0	5	12	6	3	0	0	0	0	0	0	0	27
4:00 AM	0	0	0	0	0	1	14	25	9	5	0	0	0	0	0	0	0	54
5:00 AM	0	0	0	0	2	13	50	90	34	7	1	0	0	0	0	0	0	197
6:00 AM	0	1	2	1	13	48	158	168	74	17	3	0	0	0	0	0	0	485
7:00 AM	0	5	3	3	25	85	160	146	59	11	3	1	0	0	0	0	0	501
8:00 AM	0	0	0	4	26	86	191	189	60	7	1	0	0	0	0	0	0	564
9:00 AM	0	0	0	2	21	53	162	159	31	5	2	0	0	0	0	0	0	435
10:00 AM	0	0	0	2	28	79	163	122	31	3	1	0	0	0	0	0	0	429
11:00 AM	0	0	1	13	28	102	195	138	36	3	2	0	0	0	0	0	0	518
12:00 PM	0	0	0	4	64	144	231	135	23	7	0	0	0	0	0	0	0	608
1:00 PM	1	2	9	10	42	148	207	150	38	3	2	0	0	0	0	0	0	612
2:00 PM	0	0	1	4	37	124	248	125	28	10	0	1	0	0	0	0	0	578
3:00 PM	0	0	3	10	63	151	217	146	34	3	0	0	0	0	0	0	0	627
4:00 PM	0	0	3	10	38	136	250	155	44	11	3	0	0	0	0	0	0	650
5:00 PM	1	2	7	22	52	137	276	199	46	6	0	0	0	0	0	0	0	748
6:00 PM	0	0	0	1	6	73	180	136	45	10	3	1	0	0	0	0	0	455
7:00 PM	0	0	0	0	3	35	126	147	46	8	1	0	0	0	0	0	0	366
8:00 PM	0	0	0	0	2	29	99	90	34	7	1	0	0	0	0	0	0	262
9:00 PM	0	0	0	0	5	32	65	62	25	5	0	0	0	0	0	0	0	194
10:00 PM	0	0	0	0	3	15	44	46	28	4	1	0	0	0	0	0	0	141
11:00 PM	0	0	0	1	2	4	17	25	14	7	3	1	0	0	0	0	0	74
<b>Total</b>	<b>2</b>	<b>10</b>	<b>29</b>	<b>87</b>	<b>465</b>	<b>1,500</b>	<b>3,078</b>	<b>2,486</b>	<b>761</b>	<b>149</b>	<b>28</b>	<b>5</b>	<b>1</b>	<b>0</b>	<b>0</b>	<b>0</b>	<b>0</b>	<b>8,601</b>
<b>Percent</b>	<b>0.0%</b>	<b>0.1%</b>	<b>0.3%</b>	<b>1.0%</b>	<b>5.4%</b>	<b>17.4%</b>	<b>35.8%</b>	<b>28.9%</b>	<b>8.8%</b>	<b>1.7%</b>	<b>0.3%</b>	<b>0.1%</b>	<b>0.0%</b>	<b>0.0%</b>	<b>0.0%</b>	<b>0.0%</b>	<b>0.0%</b>	<b>0.0%</b>

Note: Average only considered on days with 24-hours of data.

Total Study Percentile Speed Summary		Total Study Speed Statistics	
50th Percentile (Median)	38.7 mph	Mean (Average) Speed	38.5 mph
85th Percentile	44.0 mph	10 mph Pace	33.9 - 43.9 mph
95th Percentile	47.4 mph	Percent in Pace	65.8 %



Location: Shiloh Rd, BTW Conde Ln & US-101 Ramps  
 Date Range: 7/28/2022 - 8/3/2022  
 Site Code: 03

Time	Thursday			Friday			Saturday			Sunday			Monday			Tuesday			Wednesday			Mid-Week Average		
	7/28/2022			7/29/2022			7/30/2022			7/31/2022			8/1/2022			8/2/2022			8/3/2022					
	EB	WB	Total	EB	WB	Total	EB	WB	Total	EB	WB	Total	EB	WB	Total	EB	WB	Total	EB	WB	Total	EB	WB	Total
12:00 AM	35	31	66	-	-	-	-	-	-	-	-	-	-	-	-	-	-	-	-	-	-	35	31	66
1:00 AM	28	27	55	-	-	-	-	-	-	-	-	-	-	-	-	-	-	-	-	-	-	28	27	55
2:00 AM	13	18	31	-	-	-	-	-	-	-	-	-	-	-	-	-	-	-	-	-	-	13	18	31
3:00 AM	23	27	50	-	-	-	-	-	-	-	-	-	-	-	-	-	-	-	-	-	-	23	27	50
4:00 AM	52	54	106	-	-	-	-	-	-	-	-	-	-	-	-	-	-	-	-	-	-	52	54	106
5:00 AM	157	197	354	-	-	-	-	-	-	-	-	-	-	-	-	-	-	-	-	-	-	157	197	354
6:00 AM	285	485	770	-	-	-	-	-	-	-	-	-	-	-	-	-	-	-	-	-	-	285	485	770
7:00 AM	477	501	978	-	-	-	-	-	-	-	-	-	-	-	-	-	-	-	-	-	-	477	501	978
8:00 AM	535	564	1,099	-	-	-	-	-	-	-	-	-	-	-	-	-	-	-	-	-	-	535	564	1,099
9:00 AM	507	435	942	-	-	-	-	-	-	-	-	-	-	-	-	-	-	-	-	-	-	507	435	942
10:00 AM	525	429	954	-	-	-	-	-	-	-	-	-	-	-	-	-	-	-	-	-	-	525	429	954
11:00 AM	619	518	1,137	-	-	-	-	-	-	-	-	-	-	-	-	-	-	-	-	-	-	619	518	1,137
12:00 PM	607	608	1,215	-	-	-	-	-	-	-	-	-	-	-	-	-	-	-	-	-	-	607	608	1,215
1:00 PM	591	612	1,203	-	-	-	-	-	-	-	-	-	-	-	-	-	-	-	-	-	-	591	612	1,203
2:00 PM	667	578	1,245	-	-	-	-	-	-	-	-	-	-	-	-	-	-	-	-	-	-	667	578	1,245
3:00 PM	722	627	1,349	-	-	-	-	-	-	-	-	-	-	-	-	-	-	-	-	-	-	722	627	1,349
4:00 PM	840	650	1,490	-	-	-	-	-	-	-	-	-	-	-	-	-	-	-	-	-	-	840	650	1,490
5:00 PM	608	748	1,356	-	-	-	-	-	-	-	-	-	-	-	-	-	-	-	-	-	-	608	748	1,356
6:00 PM	489	455	944	-	-	-	-	-	-	-	-	-	-	-	-	-	-	-	-	-	-	489	455	944
7:00 PM	392	366	758	-	-	-	-	-	-	-	-	-	-	-	-	-	-	-	-	-	-	392	366	758
8:00 PM	302	262	564	-	-	-	-	-	-	-	-	-	-	-	-	-	-	-	-	-	-	302	262	564
9:00 PM	237	194	431	-	-	-	-	-	-	-	-	-	-	-	-	-	-	-	-	-	-	237	194	431
10:00 PM	152	141	293	-	-	-	-	-	-	-	-	-	-	-	-	-	-	-	-	-	-	152	141	293
11:00 PM	71	74	145	-	-	-	-	-	-	-	-	-	-	-	-	-	-	-	-	-	-	71	74	145
Total	8,934	8,601	17,535	-	-	-	-	-	-	-	-	-	-	-	-	-	-	-	-	-	-	8,934	8,601	17,535
Percent	51%	49%	-	-	-	-	-	-	-	-	-	-	-	-	-	-	-	-	-	-	-	51%	49%	-
AM Peak	11:00	08:00	11:00	-	-	-	-	-	-	-	-	-	-	-	-	-	-	-	-	-	-	11:00	08:00	11:00
Vol.	619	564	1,137	-	-	-	-	-	-	-	-	-	-	-	-	-	-	-	-	-	-	619	564	1,137
PM Peak	16:00	17:00	16:00	-	-	-	-	-	-	-	-	-	-	-	-	-	-	-	-	-	-	16:00	17:00	16:00
Vol.	840	748	1,490	-	-	-	-	-	-	-	-	-	-	-	-	-	-	-	-	-	-	840	748	1,490

1. Mid-week average includes data between Tuesday and Thursday.

## Vehicle Classification Report Summary



**Location:** Shiloh Rd, BTW US-101 NB Ramps & US-101 SB Ramps

**Count Direction:** Eastbound / Westbound

**Date Range:** 7/28/2022 to 7/28/2022

**Site Code:** 04

	FHWA Vehicle Classification													Total Volume
	1	2	3	4	5	6	7	8	9	10	11	12	13	
<b>Study Total</b>														
<b>Eastbound</b>	88	5,204	948	5	208	526	0	9	16	19	5	3	20	7,051
<b>Percent</b>	1.2%	73.8%	13.4%	0.1%	2.9%	7.5%	0.0%	0.1%	0.2%	0.3%	0.1%	0.0%	0.3%	100%
<b>Westbound</b>	102	9,416	2,583	80	1,723	97	0	27	107	10	3	0	8	14,156
<b>Percent</b>	0.7%	66.5%	18.2%	0.6%	12.2%	0.7%	0.0%	0.2%	0.8%	0.1%	0.0%	0.0%	0.1%	100%
<b>Total</b>	190	14,620	3,531	85	1,931	623	0	36	123	29	8	3	28	21,207
<b>Percent</b>	0.9%	68.9%	16.7%	0.4%	9.1%	2.9%	0.0%	0.2%	0.6%	0.1%	0.0%	0.0%	0.1%	100%

<b>FHWA Vehicle Classification</b>	
Class 1 - Motorcycles	Class 8 - Four or Fewer Axle Single-Trailer Trucks
Class 2 - Passenger Cars	Class 9 - Five-Axle Single-Trailer Trucks
Class 3 - Other Two-Axle, Four-Tire Single Unit Vehicles	Class 10 - Six or More Axle Single-Trailer Trucks
Class 4 - Buses	Class 11 - Five or fewer Axle Multi-Trailer Trucks
Class 5 - Two-Axle, Six-Tire, Single-Unit Trucks	Class 12 - Six-Axle Multi-Trailer Trucks
Class 6 - Three-Axle Single-Unit Trucks	Class 13 - Seven or More Axle Multi-Trailer Trucks
Class 7 - Four or More Axle Single-Unit Trucks	

**Location:** Shiloh Rd, BTW US-101 NB Ramps & US-101 SB Ramps  
**Date Range:** 7/28/2022 to 7/28/2022  
**Site Code:** 04

**Thursday, July 28, 2022**  
**Eastbound**

Time	FHWA Vehicle Classification													Total Volume
	1	2	3	4	5	6	7	8	9	10	11	12	13	
12:00 AM	0	16	5	0	1	4	0	0	0	0	0	0	1	27
1:00 AM	0	8	3	0	0	1	0	0	0	0	0	0	0	12
2:00 AM	0	3	1	0	0	0	0	0	0	0	0	0	0	4
3:00 AM	0	7	0	0	1	0	0	0	0	0	0	0	0	8
4:00 AM	0	23	4	0	4	3	0	0	3	0	0	0	0	37
5:00 AM	0	73	10	0	9	8	0	1	3	0	0	0	0	104
6:00 AM	0	92	30	0	11	19	0	1	1	1	1	0	0	156
7:00 AM	0	162	38	0	25	25	0	1	0	5	1	0	0	257
8:00 AM	4	258	40	0	18	26	0	3	1	1	0	0	0	351
9:00 AM	3	272	61	1	15	36	0	0	0	2	2	0	3	395
10:00 AM	8	351	69	0	13	31	0	0	1	0	1	0	0	474
11:00 AM	8	414	86	1	15	40	0	0	0	0	0	0	2	566
12:00 PM	13	374	90	1	19	35	0	0	1	1	0	0	3	537
1:00 PM	7	372	66	0	14	32	0	0	0	0	0	0	3	494
2:00 PM	12	489	79	0	13	34	0	0	1	4	0	1	2	635
3:00 PM	5	498	82	1	8	40	0	2	3	3	0	1	3	646
4:00 PM	4	536	85	0	13	45	0	0	0	1	0	0	1	685
5:00 PM	9	408	67	0	6	40	0	0	1	0	0	1	1	533
6:00 PM	5	274	49	0	3	35	0	0	0	1	0	0	1	368
7:00 PM	4	217	38	0	8	29	0	0	0	0	0	0	0	296
8:00 PM	1	182	17	1	4	20	0	1	0	0	0	0	0	226
9:00 PM	4	108	21	0	5	12	0	0	0	0	0	0	0	150
10:00 PM	1	43	5	0	3	4	0	0	1	0	0	0	0	57
11:00 PM	0	24	2	0	0	7	0	0	0	0	0	0	0	33
<b>Total</b>	<b>88</b>	<b>5,204</b>	<b>948</b>	<b>5</b>	<b>208</b>	<b>526</b>	<b>0</b>	<b>9</b>	<b>16</b>	<b>19</b>	<b>5</b>	<b>3</b>	<b>20</b>	<b>7,051</b>
<b>Percent</b>	<b>1.2%</b>	<b>73.8%</b>	<b>13.4%</b>	<b>0.1%</b>	<b>2.9%</b>	<b>7.5%</b>	<b>0.0%</b>	<b>0.1%</b>	<b>0.2%</b>	<b>0.3%</b>	<b>0.1%</b>	<b>0.0%</b>	<b>0.3%</b>	

**Location:** Shiloh Rd, BTW US-101 NB Ramps & US-101 SB Ramps  
**Date Range:** 7/28/2022 to 7/28/2022  
**Site Code:** 04

**Thursday, July 28, 2022**  
**Westbound**

Time	FHWA Vehicle Classification													Total Volume
	1	2	3	4	5	6	7	8	9	10	11	12	13	
12:00 AM	0	30	3	0	4	0	0	0	2	0	0	0	0	39
1:00 AM	0	36	5	0	3	1	0	0	2	0	0	0	0	47
2:00 AM	0	34	8	1	4	0	0	0	0	0	0	0	0	47
3:00 AM	0	28	8	0	8	0	0	0	2	0	0	0	0	46
4:00 AM	1	73	29	2	16	1	0	0	6	0	0	0	0	128
5:00 AM	4	210	70	8	65	14	0	1	6	0	1	0	0	379
6:00 AM	8	457	171	7	107	12	0	3	7	0	0	0	1	773
7:00 AM	10	550	179	8	108	18	0	4	9	0	0	0	0	886
8:00 AM	6	577	164	12	116	6	0	1	14	1	0	0	0	897
9:00 AM	4	482	157	10	102	14	0	5	7	1	0	0	0	782
10:00 AM	8	477	163	6	121	4	0	0	5	0	0	0	0	784
11:00 AM	4	583	143	6	107	6	0	2	11	1	0	0	1	864
12:00 PM	5	646	193	3	125	1	0	4	5	0	0	0	0	982
1:00 PM	10	632	165	6	127	1	0	2	8	3	1	0	0	955
2:00 PM	8	656	196	7	154	6	0	2	4	0	1	0	3	1,037
3:00 PM	3	702	190	3	137	3	0	1	6	1	0	0	1	1,047
4:00 PM	6	647	162	1	139	3	0	0	5	1	0	0	0	964
5:00 PM	9	759	164	0	104	2	0	1	2	2	0	0	0	1,043
6:00 PM	6	552	141	0	59	0	0	1	2	0	0	0	2	763
7:00 PM	2	436	101	0	34	2	0	0	0	0	0	0	0	575
8:00 PM	1	333	68	0	37	1	0	0	2	0	0	0	0	442
9:00 PM	3	265	53	0	17	1	0	0	2	0	0	0	0	341
10:00 PM	3	170	37	0	22	1	0	0	0	0	0	0	0	233
11:00 PM	1	81	13	0	7	0	0	0	0	0	0	0	0	102
<b>Total</b>	<b>102</b>	<b>9,416</b>	<b>2,583</b>	<b>80</b>	<b>1,723</b>	<b>97</b>	<b>0</b>	<b>27</b>	<b>107</b>	<b>10</b>	<b>3</b>	<b>0</b>	<b>8</b>	<b>14,156</b>
<b>Percent</b>	<b>0.7%</b>	<b>66.5%</b>	<b>18.2%</b>	<b>0.6%</b>	<b>12.2%</b>	<b>0.7%</b>	<b>0.0%</b>	<b>0.2%</b>	<b>0.8%</b>	<b>0.1%</b>	<b>0.0%</b>	<b>0.0%</b>	<b>0.1%</b>	

**Location:** Shiloh Rd, BTW US-101 NB Ramps & US-101 SB Ramps  
**Date Range:** 7/28/2022 to 7/28/2022  
**Site Code:** 04

**Total Study Average  
Eastbound**

Time	FHWA Vehicle Classification													Total Volume
	1	2	3	4	5	6	7	8	9	10	11	12	13	
12:00 AM	0	16	5	0	1	4	0	0	0	0	0	0	1	27
1:00 AM	0	8	3	0	0	1	0	0	0	0	0	0	0	12
2:00 AM	0	3	1	0	0	0	0	0	0	0	0	0	0	4
3:00 AM	0	7	0	0	1	0	0	0	0	0	0	0	0	8
4:00 AM	0	23	4	0	4	3	0	0	3	0	0	0	0	37
5:00 AM	0	73	10	0	9	8	0	1	3	0	0	0	0	104
6:00 AM	0	92	30	0	11	19	0	1	1	1	1	0	0	156
7:00 AM	0	162	38	0	25	25	0	1	0	5	1	0	0	257
8:00 AM	4	258	40	0	18	26	0	3	1	1	0	0	0	351
9:00 AM	3	272	61	1	15	36	0	0	0	2	2	0	3	395
10:00 AM	8	351	69	0	13	31	0	0	1	0	1	0	0	474
11:00 AM	8	414	86	1	15	40	0	0	0	0	0	0	2	566
12:00 PM	13	374	90	1	19	35	0	0	1	1	0	0	3	537
1:00 PM	7	372	66	0	14	32	0	0	0	0	0	0	3	494
2:00 PM	12	489	79	0	13	34	0	0	1	4	0	1	2	635
3:00 PM	5	498	82	1	8	40	0	2	3	3	0	1	3	646
4:00 PM	4	536	85	0	13	45	0	0	0	1	0	0	1	685
5:00 PM	9	408	67	0	6	40	0	0	1	0	0	1	1	533
6:00 PM	5	274	49	0	3	35	0	0	0	1	0	0	1	368
7:00 PM	4	217	38	0	8	29	0	0	0	0	0	0	0	296
8:00 PM	1	182	17	1	4	20	0	1	0	0	0	0	0	226
9:00 PM	4	108	21	0	5	12	0	0	0	0	0	0	0	150
10:00 PM	1	43	5	0	3	4	0	0	1	0	0	0	0	57
11:00 PM	0	24	2	0	0	7	0	0	0	0	0	0	0	33
<b>Total</b>	<b>88</b>	<b>5,204</b>	<b>948</b>	<b>5</b>	<b>208</b>	<b>526</b>	<b>0</b>	<b>9</b>	<b>16</b>	<b>19</b>	<b>5</b>	<b>3</b>	<b>20</b>	<b>7,051</b>
<b>Percent</b>	<b>1.2%</b>	<b>73.8%</b>	<b>13.4%</b>	<b>0.1%</b>	<b>2.9%</b>	<b>7.5%</b>	<b>0.0%</b>	<b>0.1%</b>	<b>0.2%</b>	<b>0.3%</b>	<b>0.1%</b>	<b>0.0%</b>	<b>0.3%</b>	

Note: Average only considered on days with 24-hours of data.

**Location:** Shiloh Rd, BTW US-101 NB Ramps & US-101 SB Ramps  
**Date Range:** 7/28/2022 to 7/28/2022  
**Site Code:** 04

**Total Study Average  
 Westbound**

Time	FHWA Vehicle Classification													Total Volume
	1	2	3	4	5	6	7	8	9	10	11	12	13	
12:00 AM	0	30	3	0	4	0	0	0	2	0	0	0	0	39
1:00 AM	0	36	5	0	3	1	0	0	2	0	0	0	0	47
2:00 AM	0	34	8	1	4	0	0	0	0	0	0	0	0	47
3:00 AM	0	28	8	0	8	0	0	0	2	0	0	0	0	46
4:00 AM	1	73	29	2	16	1	0	0	6	0	0	0	0	128
5:00 AM	4	210	70	8	65	14	0	1	6	0	1	0	0	379
6:00 AM	8	457	171	7	107	12	0	3	7	0	0	0	1	773
7:00 AM	10	550	179	8	108	18	0	4	9	0	0	0	0	886
8:00 AM	6	577	164	12	116	6	0	1	14	1	0	0	0	897
9:00 AM	4	482	157	10	102	14	0	5	7	1	0	0	0	782
10:00 AM	8	477	163	6	121	4	0	0	5	0	0	0	0	784
11:00 AM	4	583	143	6	107	6	0	2	11	1	0	0	1	864
12:00 PM	5	646	193	3	125	1	0	4	5	0	0	0	0	982
1:00 PM	10	632	165	6	127	1	0	2	8	3	1	0	0	955
2:00 PM	8	656	196	7	154	6	0	2	4	0	1	0	3	1,037
3:00 PM	3	702	190	3	137	3	0	1	6	1	0	0	1	1,047
4:00 PM	6	647	162	1	139	3	0	0	5	1	0	0	0	964
5:00 PM	9	759	164	0	104	2	0	1	2	2	0	0	0	1,043
6:00 PM	6	552	141	0	59	0	0	1	2	0	0	0	2	763
7:00 PM	2	436	101	0	34	2	0	0	0	0	0	0	0	575
8:00 PM	1	333	68	0	37	1	0	0	2	0	0	0	0	442
9:00 PM	3	265	53	0	17	1	0	0	2	0	0	0	0	341
10:00 PM	3	170	37	0	22	1	0	0	0	0	0	0	0	233
11:00 PM	1	81	13	0	7	0	0	0	0	0	0	0	0	102
<b>Total</b>	<b>102</b>	<b>9,416</b>	<b>2,583</b>	<b>80</b>	<b>1,723</b>	<b>97</b>	<b>0</b>	<b>27</b>	<b>107</b>	<b>10</b>	<b>3</b>	<b>0</b>	<b>8</b>	<b>14,156</b>
<b>Percent</b>	<b>0.7%</b>	<b>66.5%</b>	<b>18.2%</b>	<b>0.6%</b>	<b>12.2%</b>	<b>0.7%</b>	<b>0.0%</b>	<b>0.2%</b>	<b>0.8%</b>	<b>0.1%</b>	<b>0.0%</b>	<b>0.0%</b>	<b>0.1%</b>	

Note: Average only considered on days with 24-hours of data.

**Location:** Shiloh Rd, BTW US-101 NB Ramps & US-101 SB Ramps  
**Date Range:** 7/28/2022 to 7/28/2022  
**Site Code:** 04

**3-Day (Tuesday - Thursday) Average  
Eastbound**

Time	FHWA Vehicle Classification													Total Volume
	1	2	3	4	5	6	7	8	9	10	11	12	13	
12:00 AM	0	16	5	0	1	4	0	0	0	0	0	0	1	27
1:00 AM	0	8	3	0	0	1	0	0	0	0	0	0	0	12
2:00 AM	0	3	1	0	0	0	0	0	0	0	0	0	0	4
3:00 AM	0	7	0	0	1	0	0	0	0	0	0	0	0	8
4:00 AM	0	23	4	0	4	3	0	0	3	0	0	0	0	37
5:00 AM	0	73	10	0	9	8	0	1	3	0	0	0	0	104
6:00 AM	0	92	30	0	11	19	0	1	1	1	1	0	0	156
7:00 AM	0	162	38	0	25	25	0	1	0	5	1	0	0	257
8:00 AM	4	258	40	0	18	26	0	3	1	1	0	0	0	351
9:00 AM	3	272	61	1	15	36	0	0	0	2	2	0	3	395
10:00 AM	8	351	69	0	13	31	0	0	1	0	1	0	0	474
11:00 AM	8	414	86	1	15	40	0	0	0	0	0	0	2	566
12:00 PM	13	374	90	1	19	35	0	0	1	1	0	0	3	537
1:00 PM	7	372	66	0	14	32	0	0	0	0	0	0	3	494
2:00 PM	12	489	79	0	13	34	0	0	1	4	0	1	2	635
3:00 PM	5	498	82	1	8	40	0	2	3	3	0	1	3	646
4:00 PM	4	536	85	0	13	45	0	0	0	1	0	0	1	685
5:00 PM	9	408	67	0	6	40	0	0	1	0	0	1	1	533
6:00 PM	5	274	49	0	3	35	0	0	0	1	0	0	1	368
7:00 PM	4	217	38	0	8	29	0	0	0	0	0	0	0	296
8:00 PM	1	182	17	1	4	20	0	1	0	0	0	0	0	226
9:00 PM	4	108	21	0	5	12	0	0	0	0	0	0	0	150
10:00 PM	1	43	5	0	3	4	0	0	1	0	0	0	0	57
11:00 PM	0	24	2	0	0	7	0	0	0	0	0	0	0	33
<b>Total</b>	<b>88</b>	<b>5,204</b>	<b>948</b>	<b>5</b>	<b>208</b>	<b>526</b>	<b>0</b>	<b>9</b>	<b>16</b>	<b>19</b>	<b>5</b>	<b>3</b>	<b>20</b>	<b>7,051</b>
<b>Percent</b>	<b>1.2%</b>	<b>73.8%</b>	<b>13.4%</b>	<b>0.1%</b>	<b>2.9%</b>	<b>7.5%</b>	<b>0.0%</b>	<b>0.1%</b>	<b>0.2%</b>	<b>0.3%</b>	<b>0.1%</b>	<b>0.0%</b>	<b>0.3%</b>	

**Location:** Shiloh Rd, BTW US-101 NB Ramps & US-101 SB Ramps  
**Date Range:** 7/28/2022 to 7/28/2022  
**Site Code:** 04

**3-Day (Tuesday - Thursday) Average  
 Westbound**

Time	FHWA Vehicle Classification													Total Volume
	1	2	3	4	5	6	7	8	9	10	11	12	13	
12:00 AM	0	30	3	0	4	0	0	0	2	0	0	0	0	39
1:00 AM	0	36	5	0	3	1	0	0	2	0	0	0	0	47
2:00 AM	0	34	8	1	4	0	0	0	0	0	0	0	0	47
3:00 AM	0	28	8	0	8	0	0	0	2	0	0	0	0	46
4:00 AM	1	73	29	2	16	1	0	0	6	0	0	0	0	128
5:00 AM	4	210	70	8	65	14	0	1	6	0	1	0	0	379
6:00 AM	8	457	171	7	107	12	0	3	7	0	0	0	1	773
7:00 AM	10	550	179	8	108	18	0	4	9	0	0	0	0	886
8:00 AM	6	577	164	12	116	6	0	1	14	1	0	0	0	897
9:00 AM	4	482	157	10	102	14	0	5	7	1	0	0	0	782
10:00 AM	8	477	163	6	121	4	0	0	5	0	0	0	0	784
11:00 AM	4	583	143	6	107	6	0	2	11	1	0	0	1	864
12:00 PM	5	646	193	3	125	1	0	4	5	0	0	0	0	982
1:00 PM	10	632	165	6	127	1	0	2	8	3	1	0	0	955
2:00 PM	8	656	196	7	154	6	0	2	4	0	1	0	3	1,037
3:00 PM	3	702	190	3	137	3	0	1	6	1	0	0	1	1,047
4:00 PM	6	647	162	1	139	3	0	0	5	1	0	0	0	964
5:00 PM	9	759	164	0	104	2	0	1	2	2	0	0	0	1,043
6:00 PM	6	552	141	0	59	0	0	1	2	0	0	0	2	763
7:00 PM	2	436	101	0	34	2	0	0	0	0	0	0	0	575
8:00 PM	1	333	68	0	37	1	0	0	2	0	0	0	0	442
9:00 PM	3	265	53	0	17	1	0	0	2	0	0	0	0	341
10:00 PM	3	170	37	0	22	1	0	0	0	0	0	0	0	233
11:00 PM	1	81	13	0	7	0	0	0	0	0	0	0	0	102
<b>Total</b>	<b>102</b>	<b>9,416</b>	<b>2,583</b>	<b>80</b>	<b>1,723</b>	<b>97</b>	<b>0</b>	<b>27</b>	<b>107</b>	<b>10</b>	<b>3</b>	<b>0</b>	<b>8</b>	<b>14,156</b>
<b>Percent</b>	<b>0.7%</b>	<b>66.5%</b>	<b>18.2%</b>	<b>0.6%</b>	<b>12.2%</b>	<b>0.7%</b>	<b>0.0%</b>	<b>0.2%</b>	<b>0.8%</b>	<b>0.1%</b>	<b>0.0%</b>	<b>0.0%</b>	<b>0.1%</b>	



## Vehicle Speed Report Summary

**Location:** Shiloh Rd, BTW US-101 NB Ramps & US-101 SB Ramps  
**Count Direction:** Eastbound / Westbound  
**Date Range:** 7/28/2022 to 7/28/2022  
**Site Code:** 04

	Speed Range (mph)																	Total Volume
	0 - 10	10 - 15	15 - 20	20 - 25	25 - 30	30 - 35	35 - 40	40 - 45	45 - 50	50 - 55	55 - 60	60 - 65	65 - 70	70 - 75	75 - 80	80 - 85	85 +	
<b>Study Total</b>																		
<b>Eastbound</b>	3	8	22	139	1,068	2,831	2,186	666	97	22	4	2	0	0	0	1	2	7,051
<b>Percent</b>	0.0%	0.1%	0.3%	2.0%	15.1%	40.2%	31.0%	9.4%	1.4%	0.3%	0.1%	0.0%	0.0%	0.0%	0.0%	0.0%	0.0%	100%
<b>Westbound</b>	17	74	198	831	3,255	5,991	2,995	648	119	26	0	1	0	1	0	0	0	14,156
<b>Percent</b>	0.1%	0.5%	1.4%	5.9%	23.0%	42.3%	21.2%	4.6%	0.8%	0.2%	0.0%	0.0%	0.0%	0.0%	0.0%	0.0%	0.0%	100%
<b>Total</b>	20	82	220	970	4,323	8,822	5,181	1,314	216	48	4	3	0	1	0	1	2	21,207
<b>Percent</b>	0.1%	0.4%	1.0%	4.6%	20.4%	41.6%	24.4%	6.2%	1.0%	0.2%	0.0%	0.0%	0.0%	0.0%	0.0%	0.0%	0.0%	100%

Total Study Percentile Speed Summary			Total Study Speed Statistics		
<b>Eastbound</b>			<b>Eastbound</b>		
50th Percentile (Median)	34.0	mph	Mean (Average) Speed	34.2	mph
85th Percentile	38.9	mph	10 mph Pace	28.4 - 38.4	mph
95th Percentile	42.4	mph	Percent in Pace	72.8	%
<b>Westbound</b>			<b>Westbound</b>		
50th Percentile (Median)	32.2	mph	Mean (Average) Speed	32.1	mph
85th Percentile	37.0	mph	10 mph Pace	27.3 - 37.3	mph
95th Percentile	40.3	mph	Percent in Pace	70.9	%

Location: Shiloh Rd, BTW US-101 NB Ramps & US-101 SB Ramps  
 Date Range: 7/28/2022 to 7/28/2022  
 Site Code: 04

Thursday, July 28, 2022  
 Eastbound

Time	Speed Range (mph)																	Total Volume
	0 - 10	10 - 15	15 - 20	20 - 25	25 - 30	30 - 35	35 - 40	40 - 45	45 - 50	50 - 55	55 - 60	60 - 65	65 - 70	70 - 75	75 - 80	80 - 85	85 +	
12:00 AM	0	0	0	0	1	7	15	3	1	0	0	0	0	0	0	0	0	27
1:00 AM	0	0	0	0	3	3	3	1	2	0	0	0	0	0	0	0	0	12
2:00 AM	0	0	0	0	4	0	0	0	0	0	0	0	0	0	0	0	0	4
3:00 AM	0	0	0	0	1	0	5	1	0	1	0	0	0	0	0	0	0	8
4:00 AM	0	0	0	1	3	20	7	4	0	2	0	0	0	0	0	0	0	37
5:00 AM	0	0	1	6	20	37	29	6	5	0	0	0	0	0	0	0	0	104
6:00 AM	0	0	0	6	32	47	44	21	6	0	0	0	0	0	0	0	0	156
7:00 AM	0	0	0	13	52	67	85	31	5	3	1	0	0	0	0	0	0	257
8:00 AM	0	0	0	8	40	135	143	24	1	0	0	0	0	0	0	0	0	351
9:00 AM	0	0	5	24	46	143	121	53	3	0	0	0	0	0	0	0	0	395
10:00 AM	1	1	0	21	68	200	143	38	2	0	0	0	0	0	0	0	0	474
11:00 AM	0	0	5	4	122	253	150	24	5	2	0	0	0	0	0	1	0	566
12:00 PM	1	4	7	19	94	216	152	40	2	2	0	0	0	0	0	0	0	537
1:00 PM	0	0	0	1	83	230	135	28	10	2	1	2	0	0	0	0	2	494
2:00 PM	0	1	0	5	113	306	164	40	6	0	0	0	0	0	0	0	0	635
3:00 PM	1	0	0	16	140	272	176	40	1	0	0	0	0	0	0	0	0	646
4:00 PM	0	0	0	5	116	350	182	27	4	0	1	0	0	0	0	0	0	685
5:00 PM	0	1	2	8	52	209	168	79	13	1	0	0	0	0	0	0	0	533
6:00 PM	0	1	0	1	19	103	145	84	12	3	0	0	0	0	0	0	0	368
7:00 PM	0	0	0	0	20	81	147	37	9	2	0	0	0	0	0	0	0	296
8:00 PM	0	0	1	1	19	79	88	35	3	0	0	0	0	0	0	0	0	226
9:00 PM	0	0	0	0	16	49	52	26	6	1	0	0	0	0	0	0	0	150
10:00 PM	0	0	1	0	2	17	19	14	1	2	1	0	0	0	0	0	0	57
11:00 PM	0	0	0	0	2	7	13	10	0	1	0	0	0	0	0	0	0	33
<b>Total</b>	<b>3</b>	<b>8</b>	<b>22</b>	<b>139</b>	<b>1,068</b>	<b>2,831</b>	<b>2,186</b>	<b>666</b>	<b>97</b>	<b>22</b>	<b>4</b>	<b>2</b>	<b>0</b>	<b>0</b>	<b>0</b>	<b>1</b>	<b>2</b>	<b>7,051</b>
<b>Percent</b>	<b>0.0%</b>	<b>0.1%</b>	<b>0.3%</b>	<b>2.0%</b>	<b>15.1%</b>	<b>40.2%</b>	<b>31.0%</b>	<b>9.4%</b>	<b>1.4%</b>	<b>0.3%</b>	<b>0.1%</b>	<b>0.0%</b>	<b>0.0%</b>	<b>0.0%</b>	<b>0.0%</b>	<b>0.0%</b>	<b>0.0%</b>	<b>0.0%</b>

Daily Percentile Speed Summary		Speed Statistics	
50th Percentile (Median)	34.0 mph	Mean (Average) Speed	34.2 mph
85th Percentile	38.9 mph	10 mph Pace	28.4 - 38.4 mph
95th Percentile	42.4 mph	Percent in Pace	72.8 %

Location: Shiloh Rd, BTW US-101 NB Ramps & US-101 SB Ramps  
 Date Range: 7/28/2022 to 7/28/2022  
 Site Code: 04

Thursday, July 28, 2022  
 Westbound

Time	Speed Range (mph)																	Total Volume
	0 - 10	10 - 15	15 - 20	20 - 25	25 - 30	30 - 35	35 - 40	40 - 45	45 - 50	50 - 55	55 - 60	60 - 65	65 - 70	70 - 75	75 - 80	80 - 85	85 +	
12:00 AM	0	0	0	1	4	9	15	7	2	0	0	0	0	1	0	0	0	39
1:00 AM	0	0	0	2	4	8	12	12	4	5	0	0	0	0	0	0	0	47
2:00 AM	0	0	0	1	3	14	12	13	4	0	0	0	0	0	0	0	0	47
3:00 AM	0	0	0	0	4	13	16	10	3	0	0	0	0	0	0	0	0	46
4:00 AM	0	0	0	3	5	40	50	25	5	0	0	0	0	0	0	0	0	128
5:00 AM	0	0	0	8	55	145	124	35	8	4	0	0	0	0	0	0	0	379
6:00 AM	5	9	25	52	140	289	205	38	8	2	0	0	0	0	0	0	0	773
7:00 AM	0	1	8	90	168	375	206	36	1	0	0	1	0	0	0	0	0	886
8:00 AM	0	4	10	35	189	419	198	34	8	0	0	0	0	0	0	0	0	897
9:00 AM	0	0	3	40	161	383	166	22	6	1	0	0	0	0	0	0	0	782
10:00 AM	0	0	5	41	144	393	171	26	3	1	0	0	0	0	0	0	0	784
11:00 AM	1	11	16	56	237	384	133	22	4	0	0	0	0	0	0	0	0	864
12:00 PM	2	6	15	85	249	443	166	15	1	0	0	0	0	0	0	0	0	982
1:00 PM	0	0	9	79	351	350	148	17	1	0	0	0	0	0	0	0	0	955
2:00 PM	5	8	44	88	372	417	91	11	0	1	0	0	0	0	0	0	0	1,037
3:00 PM	2	13	19	84	375	420	121	9	4	0	0	0	0	0	0	0	0	1,047
4:00 PM	0	6	12	61	264	423	179	18	1	0	0	0	0	0	0	0	0	964
5:00 PM	2	11	19	66	255	448	200	36	6	0	0	0	0	0	0	0	0	1,043
6:00 PM	0	3	6	19	97	372	205	50	8	3	0	0	0	0	0	0	0	763
7:00 PM	0	0	3	6	67	244	188	57	9	1	0	0	0	0	0	0	0	575
8:00 PM	0	2	4	4	48	185	137	54	6	2	0	0	0	0	0	0	0	442
9:00 PM	0	0	0	6	37	135	120	34	7	2	0	0	0	0	0	0	0	341
10:00 PM	0	0	0	3	20	52	97	46	12	3	0	0	0	0	0	0	0	233
11:00 PM	0	0	0	1	6	30	35	21	8	1	0	0	0	0	0	0	0	102
<b>Total</b>	<b>17</b>	<b>74</b>	<b>198</b>	<b>831</b>	<b>3,255</b>	<b>5,991</b>	<b>2,995</b>	<b>648</b>	<b>119</b>	<b>26</b>	<b>0</b>	<b>1</b>	<b>0</b>	<b>1</b>	<b>0</b>	<b>0</b>	<b>0</b>	<b>14,156</b>
<b>Percent</b>	<b>0.1%</b>	<b>0.5%</b>	<b>1.4%</b>	<b>5.9%</b>	<b>23.0%</b>	<b>42.3%</b>	<b>21.2%</b>	<b>4.6%</b>	<b>0.8%</b>	<b>0.2%</b>	<b>0.0%</b>	<b>0.0%</b>	<b>0.0%</b>	<b>0.0%</b>	<b>0.0%</b>	<b>0.0%</b>	<b>0.0%</b>	<b>0.0%</b>

Daily Percentile Speed Summary		Speed Statistics	
50th Percentile (Median)	32.2 mph	Mean (Average) Speed	32.1 mph
85th Percentile	37.0 mph	10 mph Pace	27.3 - 37.3 mph
95th Percentile	40.3 mph	Percent in Pace	70.9 %

**Location:** Shiloh Rd, BTW US-101 NB Ramps & US-101 SB Ramps  
**Date Range:** 7/28/2022 to 7/28/2022  
**Site Code:** 04

**Total Study Average  
Eastbound**

Time	Speed Range (mph)																	Total Volume
	0 - 10	10 - 15	15 - 20	20 - 25	25 - 30	30 - 35	35 - 40	40 - 45	45 - 50	50 - 55	55 - 60	60 - 65	65 - 70	70 - 75	75 - 80	80 - 85	85 +	
12:00 AM	0	0	0	0	1	7	15	3	1	0	0	0	0	0	0	0	0	27
1:00 AM	0	0	0	0	3	3	3	1	2	0	0	0	0	0	0	0	0	12
2:00 AM	0	0	0	0	4	0	0	0	0	0	0	0	0	0	0	0	0	4
3:00 AM	0	0	0	0	1	0	5	1	0	1	0	0	0	0	0	0	0	8
4:00 AM	0	0	0	1	3	20	7	4	0	2	0	0	0	0	0	0	0	37
5:00 AM	0	0	1	6	20	37	29	6	5	0	0	0	0	0	0	0	0	104
6:00 AM	0	0	0	6	32	47	44	21	6	0	0	0	0	0	0	0	0	156
7:00 AM	0	0	0	13	52	67	85	31	5	3	1	0	0	0	0	0	0	257
8:00 AM	0	0	0	8	40	135	143	24	1	0	0	0	0	0	0	0	0	351
9:00 AM	0	0	5	24	46	143	121	53	3	0	0	0	0	0	0	0	0	395
10:00 AM	1	1	0	21	68	200	143	38	2	0	0	0	0	0	0	0	0	474
11:00 AM	0	0	5	4	122	253	150	24	5	2	0	0	0	0	0	1	0	566
12:00 PM	1	4	7	19	94	216	152	40	2	2	0	0	0	0	0	0	0	537
1:00 PM	0	0	0	1	83	230	135	28	10	2	1	2	0	0	0	0	2	494
2:00 PM	0	1	0	5	113	306	164	40	6	0	0	0	0	0	0	0	0	635
3:00 PM	1	0	0	16	140	272	176	40	1	0	0	0	0	0	0	0	0	646
4:00 PM	0	0	0	5	116	350	182	27	4	0	1	0	0	0	0	0	0	685
5:00 PM	0	1	2	8	52	209	168	79	13	1	0	0	0	0	0	0	0	533
6:00 PM	0	1	0	1	19	103	145	84	12	3	0	0	0	0	0	0	0	368
7:00 PM	0	0	0	0	20	81	147	37	9	2	0	0	0	0	0	0	0	296
8:00 PM	0	0	1	1	19	79	88	35	3	0	0	0	0	0	0	0	0	226
9:00 PM	0	0	0	0	16	49	52	26	6	1	0	0	0	0	0	0	0	150
10:00 PM	0	0	1	0	2	17	19	14	1	2	1	0	0	0	0	0	0	57
11:00 PM	0	0	0	0	2	7	13	10	0	1	0	0	0	0	0	0	0	33
<b>Total</b>	<b>3</b>	<b>8</b>	<b>22</b>	<b>139</b>	<b>1,068</b>	<b>2,831</b>	<b>2,186</b>	<b>666</b>	<b>97</b>	<b>22</b>	<b>4</b>	<b>2</b>	<b>0</b>	<b>0</b>	<b>0</b>	<b>1</b>	<b>2</b>	<b>7,051</b>
<b>Percent</b>	<b>0.0%</b>	<b>0.1%</b>	<b>0.3%</b>	<b>2.0%</b>	<b>15.1%</b>	<b>40.2%</b>	<b>31.0%</b>	<b>9.4%</b>	<b>1.4%</b>	<b>0.3%</b>	<b>0.1%</b>	<b>0.0%</b>	<b>0.0%</b>	<b>0.0%</b>	<b>0.0%</b>	<b>0.0%</b>	<b>0.0%</b>	<b>0.0%</b>

Note: Average only considered on days with 24-hours of data.

Total Study Percentile Speed Summary		Total Study Speed Statistics	
50th Percentile (Median)	34.0 mph	Mean (Average) Speed	34.2 mph
85th Percentile	38.9 mph	10 mph Pace	28.4 - 38.4 mph
95th Percentile	42.4 mph	Percent in Pace	72.8 %

Location: Shiloh Rd, BTW US-101 NB Ramps & US-101 SB Ramps  
 Date Range: 7/28/2022 to 7/28/2022  
 Site Code: 04

**Total Study Average  
Westbound**

Time	Speed Range (mph)																	Total Volume
	0 - 10	10 - 15	15 - 20	20 - 25	25 - 30	30 - 35	35 - 40	40 - 45	45 - 50	50 - 55	55 - 60	60 - 65	65 - 70	70 - 75	75 - 80	80 - 85	85 +	
12:00 AM	0	0	0	1	4	9	15	7	2	0	0	0	0	1	0	0	0	39
1:00 AM	0	0	0	2	4	8	12	12	4	5	0	0	0	0	0	0	0	47
2:00 AM	0	0	0	1	3	14	12	13	4	0	0	0	0	0	0	0	0	47
3:00 AM	0	0	0	0	4	13	16	10	3	0	0	0	0	0	0	0	0	46
4:00 AM	0	0	0	3	5	40	50	25	5	0	0	0	0	0	0	0	0	128
5:00 AM	0	0	0	8	55	145	124	35	8	4	0	0	0	0	0	0	0	379
6:00 AM	5	9	25	52	140	289	205	38	8	2	0	0	0	0	0	0	0	773
7:00 AM	0	1	8	90	168	375	206	36	1	0	0	1	0	0	0	0	0	886
8:00 AM	0	4	10	35	189	419	198	34	8	0	0	0	0	0	0	0	0	897
9:00 AM	0	0	3	40	161	383	166	22	6	1	0	0	0	0	0	0	0	782
10:00 AM	0	0	5	41	144	393	171	26	3	1	0	0	0	0	0	0	0	784
11:00 AM	1	11	16	56	237	384	133	22	4	0	0	0	0	0	0	0	0	864
12:00 PM	2	6	15	85	249	443	166	15	1	0	0	0	0	0	0	0	0	982
1:00 PM	0	0	9	79	351	350	148	17	1	0	0	0	0	0	0	0	0	955
2:00 PM	5	8	44	88	372	417	91	11	0	1	0	0	0	0	0	0	0	1,037
3:00 PM	2	13	19	84	375	420	121	9	4	0	0	0	0	0	0	0	0	1,047
4:00 PM	0	6	12	61	264	423	179	18	1	0	0	0	0	0	0	0	0	964
5:00 PM	2	11	19	66	255	448	200	36	6	0	0	0	0	0	0	0	0	1,043
6:00 PM	0	3	6	19	97	372	205	50	8	3	0	0	0	0	0	0	0	763
7:00 PM	0	0	3	6	67	244	188	57	9	1	0	0	0	0	0	0	0	575
8:00 PM	0	2	4	4	48	185	137	54	6	2	0	0	0	0	0	0	0	442
9:00 PM	0	0	0	6	37	135	120	34	7	2	0	0	0	0	0	0	0	341
10:00 PM	0	0	0	3	20	52	97	46	12	3	0	0	0	0	0	0	0	233
11:00 PM	0	0	0	1	6	30	35	21	8	1	0	0	0	0	0	0	0	102
<b>Total</b>	<b>17</b>	<b>74</b>	<b>198</b>	<b>831</b>	<b>3,255</b>	<b>5,991</b>	<b>2,995</b>	<b>648</b>	<b>119</b>	<b>26</b>	<b>0</b>	<b>1</b>	<b>0</b>	<b>1</b>	<b>0</b>	<b>0</b>	<b>0</b>	<b>14,156</b>
<b>Percent</b>	<b>0.1%</b>	<b>0.5%</b>	<b>1.4%</b>	<b>5.9%</b>	<b>23.0%</b>	<b>42.3%</b>	<b>21.2%</b>	<b>4.6%</b>	<b>0.8%</b>	<b>0.2%</b>	<b>0.0%</b>	<b>0.0%</b>	<b>0.0%</b>	<b>0.0%</b>	<b>0.0%</b>	<b>0.0%</b>	<b>0.0%</b>	<b>0.0%</b>

Note: Average only considered on days with 24-hours of data.

Total Study Percentile Speed Summary		Total Study Speed Statistics	
50th Percentile (Median)	32.2 mph	Mean (Average) Speed	32.1 mph
85th Percentile	37.0 mph	10 mph Pace	27.3 - 37.3 mph
95th Percentile	40.3 mph	Percent in Pace	70.9 %

Location: Shiloh Rd, BTW US-101 NB Ramps & US-101 SB Ramps  
 Date Range: 7/28/2022 - 8/3/2022  
 Site Code: 04

Time	Thursday			Friday			Saturday			Sunday			Monday			Tuesday			Wednesday			Mid-Week Average		
	7/28/2022			7/29/2022			7/30/2022			7/31/2022			8/1/2022			8/2/2022			8/3/2022					
	EB	WB	Total	EB	WB	Total	EB	WB	Total	EB	WB	Total	EB	WB	Total	EB	WB	Total	EB	WB	Total	EB	WB	Total
12:00 AM	27	39	66	-	-	-	-	-	-	-	-	-	-	-	-	-	-	-	-	-	-	27	39	66
1:00 AM	12	47	59	-	-	-	-	-	-	-	-	-	-	-	-	-	-	-	-	-	-	12	47	59
2:00 AM	4	47	51	-	-	-	-	-	-	-	-	-	-	-	-	-	-	-	-	-	-	4	47	51
3:00 AM	8	46	54	-	-	-	-	-	-	-	-	-	-	-	-	-	-	-	-	-	-	8	46	54
4:00 AM	37	128	165	-	-	-	-	-	-	-	-	-	-	-	-	-	-	-	-	-	-	37	128	165
5:00 AM	104	379	483	-	-	-	-	-	-	-	-	-	-	-	-	-	-	-	-	-	-	104	379	483
6:00 AM	156	773	929	-	-	-	-	-	-	-	-	-	-	-	-	-	-	-	-	-	-	156	773	929
7:00 AM	257	886	1,143	-	-	-	-	-	-	-	-	-	-	-	-	-	-	-	-	-	-	257	886	1,143
8:00 AM	351	897	1,248	-	-	-	-	-	-	-	-	-	-	-	-	-	-	-	-	-	-	351	897	1,248
9:00 AM	395	782	1,177	-	-	-	-	-	-	-	-	-	-	-	-	-	-	-	-	-	-	395	782	1,177
10:00 AM	474	784	1,258	-	-	-	-	-	-	-	-	-	-	-	-	-	-	-	-	-	-	474	784	1,258
11:00 AM	566	864	1,430	-	-	-	-	-	-	-	-	-	-	-	-	-	-	-	-	-	-	566	864	1,430
12:00 PM	537	982	1,519	-	-	-	-	-	-	-	-	-	-	-	-	-	-	-	-	-	-	537	982	1,519
1:00 PM	494	955	1,449	-	-	-	-	-	-	-	-	-	-	-	-	-	-	-	-	-	-	494	955	1,449
2:00 PM	635	1,037	1,672	-	-	-	-	-	-	-	-	-	-	-	-	-	-	-	-	-	-	635	1,037	1,672
3:00 PM	646	1,047	1,693	-	-	-	-	-	-	-	-	-	-	-	-	-	-	-	-	-	-	646	1,047	1,693
4:00 PM	685	964	1,649	-	-	-	-	-	-	-	-	-	-	-	-	-	-	-	-	-	-	685	964	1,649
5:00 PM	533	1,043	1,576	-	-	-	-	-	-	-	-	-	-	-	-	-	-	-	-	-	-	533	1,043	1,576
6:00 PM	368	763	1,131	-	-	-	-	-	-	-	-	-	-	-	-	-	-	-	-	-	-	368	763	1,131
7:00 PM	296	575	871	-	-	-	-	-	-	-	-	-	-	-	-	-	-	-	-	-	-	296	575	871
8:00 PM	226	442	668	-	-	-	-	-	-	-	-	-	-	-	-	-	-	-	-	-	-	226	442	668
9:00 PM	150	341	491	-	-	-	-	-	-	-	-	-	-	-	-	-	-	-	-	-	-	150	341	491
10:00 PM	57	233	290	-	-	-	-	-	-	-	-	-	-	-	-	-	-	-	-	-	-	57	233	290
11:00 PM	33	102	135	-	-	-	-	-	-	-	-	-	-	-	-	-	-	-	-	-	-	33	102	135
Total	7,051	14,156	21,207	-	-	-	-	-	-	-	-	-	-	-	-	-	-	-	-	-	-	7,051	14,156	21,207
Percent	33%	67%	-	-	-	-	-	-	-	-	-	-	-	-	-	-	-	-	-	-	-	33%	67%	-
AM Peak	11:00	08:00	11:00	-	-	-	-	-	-	-	-	-	-	-	-	-	-	-	-	-	-	11:00	08:00	11:00
Vol.	566	897	1,430	-	-	-	-	-	-	-	-	-	-	-	-	-	-	-	-	-	-	566	897	1,430
PM Peak	16:00	15:00	15:00	-	-	-	-	-	-	-	-	-	-	-	-	-	-	-	-	-	-	16:00	15:00	15:00
Vol.	685	1,047	1,693	-	-	-	-	-	-	-	-	-	-	-	-	-	-	-	-	-	-	685	1,047	1,693

1. Mid-week average includes data between Tuesday and Thursday.

## Vehicle Classification Report Summary

**Location:** Shiloh Rd, BTW Hembree Ln & Old Redwood Hwy  
**Count Direction:** Eastbound / Westbound  
**Date Range:** 7/28/2022 to 7/28/2022  
**Site Code:** 05

	FHWA Vehicle Classification													Total Volume
	1	2	3	4	5	6	7	8	9	10	11	12	13	
<b>Study Total</b>														
<b>Eastbound</b>	4	3,467	1,042	15	644	32	0	42	5	0	0	0	0	5,251
<b>Percent</b>	0.1%	66.0%	19.8%	0.3%	12.3%	0.6%	0.0%	0.8%	0.1%	0.0%	0.0%	0.0%	0.0%	100%
<b>Westbound</b>	30	3,905	841	6	313	219	0	3	0	1	0	0	0	5,318
<b>Percent</b>	0.6%	73.4%	15.8%	0.1%	5.9%	4.1%	0.0%	0.1%	0.0%	0.0%	0.0%	0.0%	0.0%	100%
<b>Total</b>	34	7,372	1,883	21	957	251	0	45	5	1	0	0	0	10,569
<b>Percent</b>	0.3%	69.8%	17.8%	0.2%	9.1%	2.4%	0.0%	0.4%	0.0%	0.0%	0.0%	0.0%	0.0%	100%

<b>FHWA Vehicle Classification</b>	
Class 1 - Motorcycles	Class 8 - Four or Fewer Axle Single-Trailer Trucks
Class 2 - Passenger Cars	Class 9 - Five-Axle Single-Trailer Trucks
Class 3 - Other Two-Axle, Four-Tire Single Unit Vehicles	Class 10 - Six or More Axle Single-Trailer Trucks
Class 4 - Buses	Class 11 - Five or fewer Axle Multi-Trailer Trucks
Class 5 - Two-Axle, Six-Tire, Single-Unit Trucks	Class 12 - Six-Axle Multi-Trailer Trucks
Class 6 - Three-Axle Single-Unit Trucks	Class 13 - Seven or More Axle Multi-Trailer Trucks
Class 7 - Four or More Axle Single-Unit Trucks	

**Location:** Shiloh Rd, BTW Hembree Ln & Old Redwood Hwy  
**Date Range:** 7/28/2022 to 7/28/2022  
**Site Code:** 05

**Thursday, July 28, 2022**  
**Eastbound**

Time	FHWA Vehicle Classification													Total Volume
	1	2	3	4	5	6	7	8	9	10	11	12	13	
12:00 AM	0	16	5	0	3	0	0	0	0	0	0	0	0	24
1:00 AM	0	16	2	0	1	0	0	0	0	0	0	0	0	19
2:00 AM	0	3	2	0	0	0	0	0	0	0	0	0	0	5
3:00 AM	0	6	5	1	1	0	0	0	0	0	0	0	0	13
4:00 AM	0	28	13	0	3	2	0	2	0	0	0	0	0	48
5:00 AM	0	91	29	0	13	3	0	9	0	0	0	0	0	145
6:00 AM	0	73	44	2	32	8	0	7	0	0	0	0	0	166
7:00 AM	0	135	57	2	41	5	0	9	0	0	0	0	0	249
8:00 AM	0	152	54	1	45	3	0	4	0	0	0	0	0	259
9:00 AM	0	150	64	0	44	6	0	6	0	0	0	0	0	270
10:00 AM	0	202	60	0	45	1	0	3	1	0	0	0	0	312
11:00 AM	0	196	71	1	61	1	0	0	0	0	0	0	0	330
12:00 PM	0	220	68	1	43	1	0	1	0	0	0	0	0	334
1:00 PM	1	241	65	2	37	0	0	0	0	0	0	0	0	346
2:00 PM	0	260	74	1	34	0	0	0	1	0	0	0	0	370
3:00 PM	0	324	76	0	54	0	0	0	2	0	0	0	0	456
4:00 PM	0	315	90	0	67	1	0	0	1	0	0	0	0	474
5:00 PM	1	282	87	0	38	1	0	0	0	0	0	0	0	409
6:00 PM	1	207	57	0	25	0	0	0	0	0	0	0	0	290
7:00 PM	0	178	40	2	22	0	0	0	0	0	0	0	0	242
8:00 PM	0	152	34	0	15	0	0	1	0	0	0	0	0	202
9:00 PM	0	126	26	1	11	0	0	0	0	0	0	0	0	164
10:00 PM	0	63	16	1	7	0	0	0	0	0	0	0	0	87
11:00 PM	1	31	3	0	2	0	0	0	0	0	0	0	0	37
<b>Total</b>	<b>4</b>	<b>3,467</b>	<b>1,042</b>	<b>15</b>	<b>644</b>	<b>32</b>	<b>0</b>	<b>42</b>	<b>5</b>	<b>0</b>	<b>0</b>	<b>0</b>	<b>0</b>	<b>5,251</b>
<b>Percent</b>	<b>0.1%</b>	<b>66.0%</b>	<b>19.8%</b>	<b>0.3%</b>	<b>12.3%</b>	<b>0.6%</b>	<b>0.0%</b>	<b>0.8%</b>	<b>0.1%</b>	<b>0.0%</b>	<b>0.0%</b>	<b>0.0%</b>	<b>0.0%</b>	



**Location:** Shiloh Rd, BTW Hembree Ln & Old Redwood Hwy  
**Date Range:** 7/28/2022 to 7/28/2022  
**Site Code:** 05

**Thursday, July 28, 2022**  
**Westbound**

Time	FHWA Vehicle Classification													Total Volume
	1	2	3	4	5	6	7	8	9	10	11	12	13	
12:00 AM	0	13	1	0	0	0	0	0	0	0	0	0	0	14
1:00 AM	0	8	3	0	0	0	0	0	0	0	0	0	0	11
2:00 AM	0	6	1	1	1	0	0	0	0	0	0	0	0	9
3:00 AM	0	6	2	0	4	0	0	0	0	0	0	0	0	12
4:00 AM	0	24	5	0	3	0	0	0	0	0	0	0	0	32
5:00 AM	0	67	23	0	22	14	0	0	0	0	0	0	0	126
6:00 AM	0	120	44	0	23	13	0	0	0	0	0	0	0	200
7:00 AM	3	152	62	0	31	17	0	2	0	1	0	0	0	268
8:00 AM	2	194	69	0	19	16	0	0	0	0	0	0	0	300
9:00 AM	2	216	63	1	14	15	0	0	0	0	0	0	0	311
10:00 AM	2	227	56	2	26	9	0	1	0	0	0	0	0	323
11:00 AM	1	233	60	1	22	13	0	0	0	0	0	0	0	330
12:00 PM	4	301	54	0	19	21	0	0	0	0	0	0	0	399
1:00 PM	4	273	42	0	25	11	0	0	0	0	0	0	0	355
2:00 PM	1	376	70	0	23	17	0	0	0	0	0	0	0	487
3:00 PM	2	390	69	0	22	21	0	0	0	0	0	0	0	504
4:00 PM	1	316	67	0	19	14	0	0	0	0	0	0	0	417
5:00 PM	5	305	46	0	14	21	0	0	0	0	0	0	0	391
6:00 PM	2	237	35	0	9	11	0	0	0	0	0	0	0	294
7:00 PM	1	164	25	0	7	2	0	0	0	0	0	0	0	199
8:00 PM	0	103	20	1	7	2	0	0	0	0	0	0	0	133
9:00 PM	0	94	14	0	2	1	0	0	0	0	0	0	0	111
10:00 PM	0	56	8	0	0	1	0	0	0	0	0	0	0	65
11:00 PM	0	24	2	0	1	0	0	0	0	0	0	0	0	27
<b>Total</b>	<b>30</b>	<b>3,905</b>	<b>841</b>	<b>6</b>	<b>313</b>	<b>219</b>	<b>0</b>	<b>3</b>	<b>0</b>	<b>1</b>	<b>0</b>	<b>0</b>	<b>0</b>	<b>5,318</b>
<b>Percent</b>	<b>0.6%</b>	<b>73.4%</b>	<b>15.8%</b>	<b>0.1%</b>	<b>5.9%</b>	<b>4.1%</b>	<b>0.0%</b>	<b>0.1%</b>	<b>0.0%</b>	<b>0.0%</b>	<b>0.0%</b>	<b>0.0%</b>	<b>0.0%</b>	

**Location:** Shiloh Rd, BTW Hembree Ln & Old Redwood Hwy  
**Date Range:** 7/28/2022 to 7/28/2022  
**Site Code:** 05

**Total Study Average  
Eastbound**

Time	FHWA Vehicle Classification													Total Volume
	1	2	3	4	5	6	7	8	9	10	11	12	13	
12:00 AM	0	16	5	0	3	0	0	0	0	0	0	0	0	24
1:00 AM	0	16	2	0	1	0	0	0	0	0	0	0	0	19
2:00 AM	0	3	2	0	0	0	0	0	0	0	0	0	0	5
3:00 AM	0	6	5	1	1	0	0	0	0	0	0	0	0	13
4:00 AM	0	28	13	0	3	2	0	2	0	0	0	0	0	48
5:00 AM	0	91	29	0	13	3	0	9	0	0	0	0	0	145
6:00 AM	0	73	44	2	32	8	0	7	0	0	0	0	0	166
7:00 AM	0	135	57	2	41	5	0	9	0	0	0	0	0	249
8:00 AM	0	152	54	1	45	3	0	4	0	0	0	0	0	259
9:00 AM	0	150	64	0	44	6	0	6	0	0	0	0	0	270
10:00 AM	0	202	60	0	45	1	0	3	1	0	0	0	0	312
11:00 AM	0	196	71	1	61	1	0	0	0	0	0	0	0	330
12:00 PM	0	220	68	1	43	1	0	1	0	0	0	0	0	334
1:00 PM	1	241	65	2	37	0	0	0	0	0	0	0	0	346
2:00 PM	0	260	74	1	34	0	0	0	1	0	0	0	0	370
3:00 PM	0	324	76	0	54	0	0	0	2	0	0	0	0	456
4:00 PM	0	315	90	0	67	1	0	0	1	0	0	0	0	474
5:00 PM	1	282	87	0	38	1	0	0	0	0	0	0	0	409
6:00 PM	1	207	57	0	25	0	0	0	0	0	0	0	0	290
7:00 PM	0	178	40	2	22	0	0	0	0	0	0	0	0	242
8:00 PM	0	152	34	0	15	0	0	1	0	0	0	0	0	202
9:00 PM	0	126	26	1	11	0	0	0	0	0	0	0	0	164
10:00 PM	0	63	16	1	7	0	0	0	0	0	0	0	0	87
11:00 PM	1	31	3	0	2	0	0	0	0	0	0	0	0	37
<b>Total</b>	<b>4</b>	<b>3,467</b>	<b>1,042</b>	<b>15</b>	<b>644</b>	<b>32</b>	<b>0</b>	<b>42</b>	<b>5</b>	<b>0</b>	<b>0</b>	<b>0</b>	<b>0</b>	<b>5,251</b>
<b>Percent</b>	<b>0.1%</b>	<b>66.0%</b>	<b>19.8%</b>	<b>0.3%</b>	<b>12.3%</b>	<b>0.6%</b>	<b>0.0%</b>	<b>0.8%</b>	<b>0.1%</b>	<b>0.0%</b>	<b>0.0%</b>	<b>0.0%</b>	<b>0.0%</b>	

Note: Average only considered on days with 24-hours of data.

**Location:** Shiloh Rd, BTW Hembree Ln & Old Redwood Hwy  
**Date Range:** 7/28/2022 to 7/28/2022  
**Site Code:** 05

**Total Study Average  
Westbound**

Time	FHWA Vehicle Classification													Total Volume
	1	2	3	4	5	6	7	8	9	10	11	12	13	
12:00 AM	0	13	1	0	0	0	0	0	0	0	0	0	0	14
1:00 AM	0	8	3	0	0	0	0	0	0	0	0	0	0	11
2:00 AM	0	6	1	1	1	0	0	0	0	0	0	0	0	9
3:00 AM	0	6	2	0	4	0	0	0	0	0	0	0	0	12
4:00 AM	0	24	5	0	3	0	0	0	0	0	0	0	0	32
5:00 AM	0	67	23	0	22	14	0	0	0	0	0	0	0	126
6:00 AM	0	120	44	0	23	13	0	0	0	0	0	0	0	200
7:00 AM	3	152	62	0	31	17	0	2	0	1	0	0	0	268
8:00 AM	2	194	69	0	19	16	0	0	0	0	0	0	0	300
9:00 AM	2	216	63	1	14	15	0	0	0	0	0	0	0	311
10:00 AM	2	227	56	2	26	9	0	1	0	0	0	0	0	323
11:00 AM	1	233	60	1	22	13	0	0	0	0	0	0	0	330
12:00 PM	4	301	54	0	19	21	0	0	0	0	0	0	0	399
1:00 PM	4	273	42	0	25	11	0	0	0	0	0	0	0	355
2:00 PM	1	376	70	0	23	17	0	0	0	0	0	0	0	487
3:00 PM	2	390	69	0	22	21	0	0	0	0	0	0	0	504
4:00 PM	1	316	67	0	19	14	0	0	0	0	0	0	0	417
5:00 PM	5	305	46	0	14	21	0	0	0	0	0	0	0	391
6:00 PM	2	237	35	0	9	11	0	0	0	0	0	0	0	294
7:00 PM	1	164	25	0	7	2	0	0	0	0	0	0	0	199
8:00 PM	0	103	20	1	7	2	0	0	0	0	0	0	0	133
9:00 PM	0	94	14	0	2	1	0	0	0	0	0	0	0	111
10:00 PM	0	56	8	0	0	1	0	0	0	0	0	0	0	65
11:00 PM	0	24	2	0	1	0	0	0	0	0	0	0	0	27
<b>Total</b>	<b>30</b>	<b>3,905</b>	<b>841</b>	<b>6</b>	<b>313</b>	<b>219</b>	<b>0</b>	<b>3</b>	<b>0</b>	<b>1</b>	<b>0</b>	<b>0</b>	<b>0</b>	<b>5,318</b>
<b>Percent</b>	<b>0.6%</b>	<b>73.4%</b>	<b>15.8%</b>	<b>0.1%</b>	<b>5.9%</b>	<b>4.1%</b>	<b>0.0%</b>	<b>0.1%</b>	<b>0.0%</b>	<b>0.0%</b>	<b>0.0%</b>	<b>0.0%</b>	<b>0.0%</b>	

Note: Average only considered on days with 24-hours of data.

**Location:** Shiloh Rd, BTW Hembree Ln & Old Redwood Hwy  
**Date Range:** 7/28/2022 to 7/28/2022  
**Site Code:** 05

**3-Day (Tuesday - Thursday) Average  
Eastbound**

Time	FHWA Vehicle Classification													Total Volume
	1	2	3	4	5	6	7	8	9	10	11	12	13	
12:00 AM	0	16	5	0	3	0	0	0	0	0	0	0	0	24
1:00 AM	0	16	2	0	1	0	0	0	0	0	0	0	0	19
2:00 AM	0	3	2	0	0	0	0	0	0	0	0	0	0	5
3:00 AM	0	6	5	1	1	0	0	0	0	0	0	0	0	13
4:00 AM	0	28	13	0	3	2	0	2	0	0	0	0	0	48
5:00 AM	0	91	29	0	13	3	0	9	0	0	0	0	0	145
6:00 AM	0	73	44	2	32	8	0	7	0	0	0	0	0	166
7:00 AM	0	135	57	2	41	5	0	9	0	0	0	0	0	249
8:00 AM	0	152	54	1	45	3	0	4	0	0	0	0	0	259
9:00 AM	0	150	64	0	44	6	0	6	0	0	0	0	0	270
10:00 AM	0	202	60	0	45	1	0	3	1	0	0	0	0	312
11:00 AM	0	196	71	1	61	1	0	0	0	0	0	0	0	330
12:00 PM	0	220	68	1	43	1	0	1	0	0	0	0	0	334
1:00 PM	1	241	65	2	37	0	0	0	0	0	0	0	0	346
2:00 PM	0	260	74	1	34	0	0	0	1	0	0	0	0	370
3:00 PM	0	324	76	0	54	0	0	0	2	0	0	0	0	456
4:00 PM	0	315	90	0	67	1	0	0	1	0	0	0	0	474
5:00 PM	1	282	87	0	38	1	0	0	0	0	0	0	0	409
6:00 PM	1	207	57	0	25	0	0	0	0	0	0	0	0	290
7:00 PM	0	178	40	2	22	0	0	0	0	0	0	0	0	242
8:00 PM	0	152	34	0	15	0	0	1	0	0	0	0	0	202
9:00 PM	0	126	26	1	11	0	0	0	0	0	0	0	0	164
10:00 PM	0	63	16	1	7	0	0	0	0	0	0	0	0	87
11:00 PM	1	31	3	0	2	0	0	0	0	0	0	0	0	37
<b>Total</b>	<b>4</b>	<b>3,467</b>	<b>1,042</b>	<b>15</b>	<b>644</b>	<b>32</b>	<b>0</b>	<b>42</b>	<b>5</b>	<b>0</b>	<b>0</b>	<b>0</b>	<b>0</b>	<b>5,251</b>
<b>Percent</b>	<b>0.1%</b>	<b>66.0%</b>	<b>19.8%</b>	<b>0.3%</b>	<b>12.3%</b>	<b>0.6%</b>	<b>0.0%</b>	<b>0.8%</b>	<b>0.1%</b>	<b>0.0%</b>	<b>0.0%</b>	<b>0.0%</b>	<b>0.0%</b>	

**Location:** Shiloh Rd, BTW Hembree Ln & Old Redwood Hwy  
**Date Range:** 7/28/2022 to 7/28/2022  
**Site Code:** 05

**3-Day (Tuesday - Thursday) Average  
 Westbound**

Time	FHWA Vehicle Classification													Total Volume
	1	2	3	4	5	6	7	8	9	10	11	12	13	
12:00 AM	0	13	1	0	0	0	0	0	0	0	0	0	0	14
1:00 AM	0	8	3	0	0	0	0	0	0	0	0	0	0	11
2:00 AM	0	6	1	1	1	0	0	0	0	0	0	0	0	9
3:00 AM	0	6	2	0	4	0	0	0	0	0	0	0	0	12
4:00 AM	0	24	5	0	3	0	0	0	0	0	0	0	0	32
5:00 AM	0	67	23	0	22	14	0	0	0	0	0	0	0	126
6:00 AM	0	120	44	0	23	13	0	0	0	0	0	0	0	200
7:00 AM	3	152	62	0	31	17	0	2	0	1	0	0	0	268
8:00 AM	2	194	69	0	19	16	0	0	0	0	0	0	0	300
9:00 AM	2	216	63	1	14	15	0	0	0	0	0	0	0	311
10:00 AM	2	227	56	2	26	9	0	1	0	0	0	0	0	323
11:00 AM	1	233	60	1	22	13	0	0	0	0	0	0	0	330
12:00 PM	4	301	54	0	19	21	0	0	0	0	0	0	0	399
1:00 PM	4	273	42	0	25	11	0	0	0	0	0	0	0	355
2:00 PM	1	376	70	0	23	17	0	0	0	0	0	0	0	487
3:00 PM	2	390	69	0	22	21	0	0	0	0	0	0	0	504
4:00 PM	1	316	67	0	19	14	0	0	0	0	0	0	0	417
5:00 PM	5	305	46	0	14	21	0	0	0	0	0	0	0	391
6:00 PM	2	237	35	0	9	11	0	0	0	0	0	0	0	294
7:00 PM	1	164	25	0	7	2	0	0	0	0	0	0	0	199
8:00 PM	0	103	20	1	7	2	0	0	0	0	0	0	0	133
9:00 PM	0	94	14	0	2	1	0	0	0	0	0	0	0	111
10:00 PM	0	56	8	0	0	1	0	0	0	0	0	0	0	65
11:00 PM	0	24	2	0	1	0	0	0	0	0	0	0	0	27
<b>Total</b>	<b>30</b>	<b>3,905</b>	<b>841</b>	<b>6</b>	<b>313</b>	<b>219</b>	<b>0</b>	<b>3</b>	<b>0</b>	<b>1</b>	<b>0</b>	<b>0</b>	<b>0</b>	<b>5,318</b>
<b>Percent</b>	<b>0.6%</b>	<b>73.4%</b>	<b>15.8%</b>	<b>0.1%</b>	<b>5.9%</b>	<b>4.1%</b>	<b>0.0%</b>	<b>0.1%</b>	<b>0.0%</b>	<b>0.0%</b>	<b>0.0%</b>	<b>0.0%</b>	<b>0.0%</b>	

## Vehicle Speed Report Summary

**Location:** Shiloh Rd, BTW Hembree Ln & Old Redwood Hwy  
**Count Direction:** Eastbound / Westbound  
**Date Range:** 7/28/2022 to 7/28/2022  
**Site Code:** 05

	Speed Range (mph)																	Total Volume
	0 - 10	10 - 15	15 - 20	20 - 25	25 - 30	30 - 35	35 - 40	40 - 45	45 - 50	50 - 55	55 - 60	60 - 65	65 - 70	70 - 75	75 - 80	80 - 85	85 +	
<b>Study Total</b>																		
<b>Eastbound</b>	0	1	7	62	462	1,690	2,021	805	162	35	2	3	1	0	0	0	0	5,251
<b>Percent</b>	0.0%	0.0%	0.1%	1.2%	8.8%	32.2%	38.5%	15.3%	3.1%	0.7%	0.0%	0.1%	0.0%	0.0%	0.0%	0.0%	0.0%	100%
<b>Westbound</b>	0	3	18	103	596	2,066	1,951	489	79	8	2	1	2	0	0	0	0	5,318
<b>Percent</b>	0.0%	0.1%	0.3%	1.9%	11.2%	38.8%	36.7%	9.2%	1.5%	0.2%	0.0%	0.0%	0.0%	0.0%	0.0%	0.0%	0.0%	100%
<b>Total</b>	0	4	25	165	1,058	3,756	3,972	1,294	241	43	4	4	3	0	0	0	0	10,569
<b>Percent</b>	0.0%	0.0%	0.2%	1.6%	10.0%	35.5%	37.6%	12.2%	2.3%	0.4%	0.0%	0.0%	0.0%	0.0%	0.0%	0.0%	0.0%	100%

Total Study Percentile Speed Summary			Total Study Speed Statistics		
<b>Eastbound</b>			<b>Eastbound</b>		
50th Percentile (Median)	35.9	mph	Mean (Average) Speed	36.0	mph
85th Percentile	40.8	mph	10 mph Pace	30.5 - 40.5	mph
95th Percentile	44.2	mph	Percent in Pace	70.9	%
<b>Westbound</b>			<b>Westbound</b>		
50th Percentile (Median)	34.7	mph	Mean (Average) Speed	34.7	mph
85th Percentile	39.0	mph	10 mph Pace	30.2 - 40.2	mph
95th Percentile	41.9	mph	Percent in Pace	75.6	%

Location: Shiloh Rd, BTW Hembree Ln & Old Redwood Hwy  
 Date Range: 7/28/2022 to 7/28/2022  
 Site Code: 05

Thursday, July 28, 2022  
 Eastbound

Time	Speed Range (mph)																	Total Volume
	0 - 10	10 - 15	15 - 20	20 - 25	25 - 30	30 - 35	35 - 40	40 - 45	45 - 50	50 - 55	55 - 60	60 - 65	65 - 70	70 - 75	75 - 80	80 - 85	85 +	
12:00 AM	0	0	0	0	0	3	8	8	4	1	0	0	0	0	0	0	0	24
1:00 AM	0	0	1	1	2	3	8	2	1	1	0	0	0	0	0	0	0	19
2:00 AM	0	0	0	0	0	3	0	1	0	1	0	0	0	0	0	0	0	5
3:00 AM	0	0	0	1	1	3	4	3	0	1	0	0	0	0	0	0	0	13
4:00 AM	0	0	1	5	6	7	10	12	7	0	0	0	0	0	0	0	0	48
5:00 AM	0	0	0	2	10	30	49	31	17	6	0	0	0	0	0	0	0	145
6:00 AM	0	0	0	4	26	35	68	25	7	1	0	0	0	0	0	0	0	166
7:00 AM	0	0	0	3	36	78	80	43	9	0	0	0	0	0	0	0	0	249
8:00 AM	0	0	0	5	10	90	108	38	6	2	0	0	0	0	0	0	0	259
9:00 AM	0	0	1	3	44	102	89	28	3	0	0	0	0	0	0	0	0	270
10:00 AM	0	0	1	8	30	104	122	40	6	1	0	0	0	0	0	0	0	312
11:00 AM	0	0	1	9	27	103	133	47	9	1	0	0	0	0	0	0	0	330
12:00 PM	0	0	0	2	28	133	120	42	7	1	0	1	0	0	0	0	0	334
1:00 PM	0	1	1	1	22	104	155	53	7	2	0	0	0	0	0	0	0	346
2:00 PM	0	0	0	5	54	133	128	43	7	0	0	0	0	0	0	0	0	370
3:00 PM	0	0	0	5	47	191	162	35	11	3	1	1	0	0	0	0	0	456
4:00 PM	0	0	1	4	39	162	180	75	13	0	0	0	0	0	0	0	0	474
5:00 PM	0	0	0	1	40	101	185	68	11	3	0	0	0	0	0	0	0	409
6:00 PM	0	0	0	1	10	105	115	50	9	0	0	0	0	0	0	0	0	290
7:00 PM	0	0	0	0	7	69	105	55	5	1	0	0	0	0	0	0	0	242
8:00 PM	0	0	0	1	10	67	75	40	7	2	0	0	0	0	0	0	0	202
9:00 PM	0	0	0	0	8	40	66	40	6	4	0	0	0	0	0	0	0	164
10:00 PM	0	0	0	1	4	19	30	22	6	2	1	1	1	0	0	0	0	87
11:00 PM	0	0	0	0	1	5	21	4	4	2	0	0	0	0	0	0	0	37
<b>Total</b>	<b>0</b>	<b>1</b>	<b>7</b>	<b>62</b>	<b>462</b>	<b>1,690</b>	<b>2,021</b>	<b>805</b>	<b>162</b>	<b>35</b>	<b>2</b>	<b>3</b>	<b>1</b>	<b>0</b>	<b>0</b>	<b>0</b>	<b>0</b>	<b>5,251</b>
<b>Percent</b>	<b>0.0%</b>	<b>0.0%</b>	<b>0.1%</b>	<b>1.2%</b>	<b>8.8%</b>	<b>32.2%</b>	<b>38.5%</b>	<b>15.3%</b>	<b>3.1%</b>	<b>0.7%</b>	<b>0.0%</b>	<b>0.1%</b>	<b>0.0%</b>	<b>0.0%</b>	<b>0.0%</b>	<b>0.0%</b>	<b>0.0%</b>	<b>0.0%</b>

Daily Percentile Speed Summary		Speed Statistics	
50th Percentile (Median)	35.9 mph	Mean (Average) Speed	36.0 mph
85th Percentile	40.8 mph	10 mph Pace	30.5 - 40.5 mph
95th Percentile	44.2 mph	Percent in Pace	70.9 %

Location: Shiloh Rd, BTW Hembree Ln & Old Redwood Hwy  
 Date Range: 7/28/2022 to 7/28/2022  
 Site Code: 05

Thursday, July 28, 2022  
 Westbound

Time	Speed Range (mph)																	Total Volume
	0 - 10	10 - 15	15 - 20	20 - 25	25 - 30	30 - 35	35 - 40	40 - 45	45 - 50	50 - 55	55 - 60	60 - 65	65 - 70	70 - 75	75 - 80	80 - 85	85 +	
12:00 AM	0	0	1	0	2	2	7	1	1	0	0	0	0	0	0	0	0	14
1:00 AM	0	0	0	0	0	5	2	2	2	0	0	0	0	0	0	0	0	11
2:00 AM	0	0	0	0	1	3	2	1	2	0	0	0	0	0	0	0	0	9
3:00 AM	0	0	0	0	1	1	5	5	0	0	0	0	0	0	0	0	0	12
4:00 AM	0	0	1	0	4	10	12	4	1	0	0	0	0	0	0	0	0	32
5:00 AM	0	0	0	2	24	35	50	12	3	0	0	0	0	0	0	0	0	126
6:00 AM	0	0	2	3	18	70	80	24	3	0	0	0	0	0	0	0	0	200
7:00 AM	0	0	3	9	31	106	90	25	4	0	0	0	0	0	0	0	0	268
8:00 AM	0	0	0	8	41	106	110	32	2	1	0	0	0	0	0	0	0	300
9:00 AM	0	1	3	7	32	127	103	32	6	0	0	0	0	0	0	0	0	311
10:00 AM	0	0	1	13	55	152	85	14	1	1	0	0	1	0	0	0	0	323
11:00 AM	0	0	0	7	33	139	124	24	2	0	0	1	0	0	0	0	0	330
12:00 PM	0	0	2	4	40	176	136	33	8	0	0	0	0	0	0	0	0	399
1:00 PM	0	1	1	11	24	136	156	24	1	1	0	0	0	0	0	0	0	355
2:00 PM	0	0	3	6	78	196	170	29	5	0	0	0	0	0	0	0	0	487
3:00 PM	0	0	0	14	69	236	150	32	3	0	0	0	0	0	0	0	0	504
4:00 PM	0	0	0	6	42	170	166	31	1	1	0	0	0	0	0	0	0	417
5:00 PM	0	0	1	8	44	135	140	49	12	1	0	0	1	0	0	0	0	391
6:00 PM	0	1	0	2	19	91	138	38	4	0	1	0	0	0	0	0	0	294
7:00 PM	0	0	0	1	9	69	82	32	6	0	0	0	0	0	0	0	0	199
8:00 PM	0	0	0	1	12	51	56	9	4	0	0	0	0	0	0	0	0	133
9:00 PM	0	0	0	0	8	36	51	15	1	0	0	0	0	0	0	0	0	111
10:00 PM	0	0	0	0	7	13	25	11	6	2	1	0	0	0	0	0	0	65
11:00 PM	0	0	0	1	2	1	11	10	1	1	0	0	0	0	0	0	0	27
<b>Total</b>	<b>0</b>	<b>3</b>	<b>18</b>	<b>103</b>	<b>596</b>	<b>2,066</b>	<b>1,951</b>	<b>489</b>	<b>79</b>	<b>8</b>	<b>2</b>	<b>1</b>	<b>2</b>	<b>0</b>	<b>0</b>	<b>0</b>	<b>0</b>	<b>5,318</b>
<b>Percent</b>	<b>0.0%</b>	<b>0.1%</b>	<b>0.3%</b>	<b>1.9%</b>	<b>11.2%</b>	<b>38.8%</b>	<b>36.7%</b>	<b>9.2%</b>	<b>1.5%</b>	<b>0.2%</b>	<b>0.0%</b>	<b>0.0%</b>	<b>0.0%</b>	<b>0.0%</b>	<b>0.0%</b>	<b>0.0%</b>	<b>0.0%</b>	<b>0.0%</b>

Daily Percentile Speed Summary		Speed Statistics	
50th Percentile (Median)	34.7 mph	Mean (Average) Speed	34.7 mph
85th Percentile	39.0 mph	10 mph Pace	30.2 - 40.2 mph
95th Percentile	41.9 mph	Percent in Pace	75.57 %



Location: Shiloh Rd, BTW Hembree Ln & Old Redwood Hwy  
 Date Range: 7/28/2022 to 7/28/2022  
 Site Code: 05

**Total Study Average  
Eastbound**

Time	Speed Range (mph)																	Total Volume
	0 - 10	10 - 15	15 - 20	20 - 25	25 - 30	30 - 35	35 - 40	40 - 45	45 - 50	50 - 55	55 - 60	60 - 65	65 - 70	70 - 75	75 - 80	80 - 85	85 +	
12:00 AM	0	0	0	0	0	3	8	8	4	1	0	0	0	0	0	0	0	24
1:00 AM	0	0	1	1	2	3	8	2	1	1	0	0	0	0	0	0	0	19
2:00 AM	0	0	0	0	0	3	0	1	0	1	0	0	0	0	0	0	0	5
3:00 AM	0	0	0	1	1	3	4	3	0	1	0	0	0	0	0	0	0	13
4:00 AM	0	0	1	5	6	7	10	12	7	0	0	0	0	0	0	0	0	48
5:00 AM	0	0	0	2	10	30	49	31	17	6	0	0	0	0	0	0	0	145
6:00 AM	0	0	0	4	26	35	68	25	7	1	0	0	0	0	0	0	0	166
7:00 AM	0	0	0	3	36	78	80	43	9	0	0	0	0	0	0	0	0	249
8:00 AM	0	0	0	5	10	90	108	38	6	2	0	0	0	0	0	0	0	259
9:00 AM	0	0	1	3	44	102	89	28	3	0	0	0	0	0	0	0	0	270
10:00 AM	0	0	1	8	30	104	122	40	6	1	0	0	0	0	0	0	0	312
11:00 AM	0	0	1	9	27	103	133	47	9	1	0	0	0	0	0	0	0	330
12:00 PM	0	0	0	2	28	133	120	42	7	1	0	1	0	0	0	0	0	334
1:00 PM	0	1	1	1	22	104	155	53	7	2	0	0	0	0	0	0	0	346
2:00 PM	0	0	0	5	54	133	128	43	7	0	0	0	0	0	0	0	0	370
3:00 PM	0	0	0	5	47	191	162	35	11	3	1	1	0	0	0	0	0	456
4:00 PM	0	0	1	4	39	162	180	75	13	0	0	0	0	0	0	0	0	474
5:00 PM	0	0	0	1	40	101	185	68	11	3	0	0	0	0	0	0	0	409
6:00 PM	0	0	0	1	10	105	115	50	9	0	0	0	0	0	0	0	0	290
7:00 PM	0	0	0	0	7	69	105	55	5	1	0	0	0	0	0	0	0	242
8:00 PM	0	0	0	1	10	67	75	40	7	2	0	0	0	0	0	0	0	202
9:00 PM	0	0	0	0	8	40	66	40	6	4	0	0	0	0	0	0	0	164
10:00 PM	0	0	0	1	4	19	30	22	6	2	1	1	1	0	0	0	0	87
11:00 PM	0	0	0	0	1	5	21	4	4	2	0	0	0	0	0	0	0	37
<b>Total</b>	<b>0</b>	<b>1</b>	<b>7</b>	<b>62</b>	<b>462</b>	<b>1,690</b>	<b>2,021</b>	<b>805</b>	<b>162</b>	<b>35</b>	<b>2</b>	<b>3</b>	<b>1</b>	<b>0</b>	<b>0</b>	<b>0</b>	<b>0</b>	<b>5,251</b>
<b>Percent</b>	<b>0.0%</b>	<b>0.0%</b>	<b>0.1%</b>	<b>1.2%</b>	<b>8.8%</b>	<b>32.2%</b>	<b>38.5%</b>	<b>15.3%</b>	<b>3.1%</b>	<b>0.7%</b>	<b>0.0%</b>	<b>0.1%</b>	<b>0.0%</b>	<b>0.0%</b>	<b>0.0%</b>	<b>0.0%</b>	<b>0.0%</b>	<b>0.0%</b>

Note: Average only considered on days with 24-hours of data.

Total Study Percentile Speed Summary		Total Study Speed Statistics	
50th Percentile (Median)	35.9 mph	Mean (Average) Speed	36.0 mph
85th Percentile	40.8 mph	10 mph Pace	30.5 - 40.5 mph
95th Percentile	44.2 mph	Percent in Pace	70.9 %

Location: Shiloh Rd, BTW Hembree Ln & Old Redwood Hwy  
 Date Range: 7/28/2022 to 7/28/2022  
 Site Code: 05

**Total Study Average  
Westbound**

Time	Speed Range (mph)																	Total Volume
	0 - 10	10 - 15	15 - 20	20 - 25	25 - 30	30 - 35	35 - 40	40 - 45	45 - 50	50 - 55	55 - 60	60 - 65	65 - 70	70 - 75	75 - 80	80 - 85	85 +	
12:00 AM	0	0	1	0	2	2	7	1	1	0	0	0	0	0	0	0	0	14
1:00 AM	0	0	0	0	0	5	2	2	2	0	0	0	0	0	0	0	0	11
2:00 AM	0	0	0	0	1	3	2	1	2	0	0	0	0	0	0	0	0	9
3:00 AM	0	0	0	0	1	1	5	5	0	0	0	0	0	0	0	0	0	12
4:00 AM	0	0	1	0	4	10	12	4	1	0	0	0	0	0	0	0	0	32
5:00 AM	0	0	0	2	24	35	50	12	3	0	0	0	0	0	0	0	0	126
6:00 AM	0	0	2	3	18	70	80	24	3	0	0	0	0	0	0	0	0	200
7:00 AM	0	0	3	9	31	106	90	25	4	0	0	0	0	0	0	0	0	268
8:00 AM	0	0	0	8	41	106	110	32	2	1	0	0	0	0	0	0	0	300
9:00 AM	0	1	3	7	32	127	103	32	6	0	0	0	0	0	0	0	0	311
10:00 AM	0	0	1	13	55	152	85	14	1	1	0	0	1	0	0	0	0	323
11:00 AM	0	0	0	7	33	139	124	24	2	0	0	1	0	0	0	0	0	330
12:00 PM	0	0	2	4	40	176	136	33	8	0	0	0	0	0	0	0	0	399
1:00 PM	0	1	1	11	24	136	156	24	1	1	0	0	0	0	0	0	0	355
2:00 PM	0	0	3	6	78	196	170	29	5	0	0	0	0	0	0	0	0	487
3:00 PM	0	0	0	14	69	236	150	32	3	0	0	0	0	0	0	0	0	504
4:00 PM	0	0	0	6	42	170	166	31	1	1	0	0	0	0	0	0	0	417
5:00 PM	0	0	1	8	44	135	140	49	12	1	0	0	1	0	0	0	0	391
6:00 PM	0	1	0	2	19	91	138	38	4	0	1	0	0	0	0	0	0	294
7:00 PM	0	0	0	1	9	69	82	32	6	0	0	0	0	0	0	0	0	199
8:00 PM	0	0	0	1	12	51	56	9	4	0	0	0	0	0	0	0	0	133
9:00 PM	0	0	0	0	8	36	51	15	1	0	0	0	0	0	0	0	0	111
10:00 PM	0	0	0	0	7	13	25	11	6	2	1	0	0	0	0	0	0	65
11:00 PM	0	0	0	1	2	1	11	10	1	1	0	0	0	0	0	0	0	27
<b>Total</b>	<b>0</b>	<b>3</b>	<b>18</b>	<b>103</b>	<b>596</b>	<b>2,066</b>	<b>1,951</b>	<b>489</b>	<b>79</b>	<b>8</b>	<b>2</b>	<b>1</b>	<b>2</b>	<b>0</b>	<b>0</b>	<b>0</b>	<b>0</b>	<b>5,318</b>
<b>Percent</b>	<b>0.0%</b>	<b>0.1%</b>	<b>0.3%</b>	<b>1.9%</b>	<b>11.2%</b>	<b>38.8%</b>	<b>36.7%</b>	<b>9.2%</b>	<b>1.5%</b>	<b>0.2%</b>	<b>0.0%</b>	<b>0.0%</b>	<b>0.0%</b>	<b>0.0%</b>	<b>0.0%</b>	<b>0.0%</b>	<b>0.0%</b>	<b>0.0%</b>

Note: Average only considered on days with 24-hours of data.

Total Study Percentile Speed Summary		Total Study Speed Statistics	
50th Percentile (Median)	34.7 mph	Mean (Average) Speed	34.7 mph
85th Percentile	39.0 mph	10 mph Pace	30.2 - 40.2 mph
95th Percentile	41.9 mph	Percent in Pace	75.6 %

Location: Shiloh Rd, BTW Hembree Ln & Old Redwood Hwy  
 Date Range: 7/28/2022 - 8/3/2022  
 Site Code: 05

Time	Thursday			Friday			Saturday			Sunday			Monday			Tuesday			Wednesday			Mid-Week Average		
	7/28/2022			7/29/2022			7/30/2022			7/31/2022			8/1/2022			8/2/2022			8/3/2022					
	EB	WB	Total	EB	WB	Total	EB	WB	Total	EB	WB	Total	EB	WB	Total	EB	WB	Total	EB	WB	Total	EB	WB	Total
12:00 AM	24	14	38	-	-	-	-	-	-	-	-	-	-	-	-	-	-	-	-	-	-	24	14	38
1:00 AM	19	11	30	-	-	-	-	-	-	-	-	-	-	-	-	-	-	-	-	-	-	19	11	30
2:00 AM	5	9	14	-	-	-	-	-	-	-	-	-	-	-	-	-	-	-	-	-	-	5	9	14
3:00 AM	13	12	25	-	-	-	-	-	-	-	-	-	-	-	-	-	-	-	-	-	-	13	12	25
4:00 AM	48	32	80	-	-	-	-	-	-	-	-	-	-	-	-	-	-	-	-	-	-	48	32	80
5:00 AM	145	126	271	-	-	-	-	-	-	-	-	-	-	-	-	-	-	-	-	-	-	145	126	271
6:00 AM	166	200	366	-	-	-	-	-	-	-	-	-	-	-	-	-	-	-	-	-	-	166	200	366
7:00 AM	249	268	517	-	-	-	-	-	-	-	-	-	-	-	-	-	-	-	-	-	-	249	268	517
8:00 AM	259	300	559	-	-	-	-	-	-	-	-	-	-	-	-	-	-	-	-	-	-	259	300	559
9:00 AM	270	311	581	-	-	-	-	-	-	-	-	-	-	-	-	-	-	-	-	-	-	270	311	581
10:00 AM	312	323	635	-	-	-	-	-	-	-	-	-	-	-	-	-	-	-	-	-	-	312	323	635
11:00 AM	330	330	660	-	-	-	-	-	-	-	-	-	-	-	-	-	-	-	-	-	-	330	330	660
12:00 PM	334	399	733	-	-	-	-	-	-	-	-	-	-	-	-	-	-	-	-	-	-	334	399	733
1:00 PM	346	355	701	-	-	-	-	-	-	-	-	-	-	-	-	-	-	-	-	-	-	346	355	701
2:00 PM	370	487	857	-	-	-	-	-	-	-	-	-	-	-	-	-	-	-	-	-	-	370	487	857
3:00 PM	456	504	960	-	-	-	-	-	-	-	-	-	-	-	-	-	-	-	-	-	-	456	504	960
4:00 PM	474	417	891	-	-	-	-	-	-	-	-	-	-	-	-	-	-	-	-	-	-	474	417	891
5:00 PM	409	391	800	-	-	-	-	-	-	-	-	-	-	-	-	-	-	-	-	-	-	409	391	800
6:00 PM	290	294	584	-	-	-	-	-	-	-	-	-	-	-	-	-	-	-	-	-	-	290	294	584
7:00 PM	242	199	441	-	-	-	-	-	-	-	-	-	-	-	-	-	-	-	-	-	-	242	199	441
8:00 PM	202	133	335	-	-	-	-	-	-	-	-	-	-	-	-	-	-	-	-	-	-	202	133	335
9:00 PM	164	111	275	-	-	-	-	-	-	-	-	-	-	-	-	-	-	-	-	-	-	164	111	275
10:00 PM	87	65	152	-	-	-	-	-	-	-	-	-	-	-	-	-	-	-	-	-	-	87	65	152
11:00 PM	37	27	64	-	-	-	-	-	-	-	-	-	-	-	-	-	-	-	-	-	-	37	27	64
Total	5,251	5,318	10,569	-	-	-	-	-	-	-	-	-	-	-	-	-	-	-	-	-	-	5,251	5,318	10,569
Percent	50%	50%	-	-	-	-	-	-	-	-	-	-	-	-	-	-	-	-	-	-	-	50%	50%	-
AM Peak	11:00	11:00	11:00	-	-	-	-	-	-	-	-	-	-	-	-	-	-	-	-	-	-	11:00	11:00	11:00
Vol.	330	330	660	-	-	-	-	-	-	-	-	-	-	-	-	-	-	-	-	-	-	330	330	660
PM Peak	16:00	15:00	15:00	-	-	-	-	-	-	-	-	-	-	-	-	-	-	-	-	-	-	16:00	15:00	15:00
Vol.	474	504	960	-	-	-	-	-	-	-	-	-	-	-	-	-	-	-	-	-	-	474	504	960

1. Mid-week average includes data between Tuesday and Thursday.























Appendix B – Existing Conditions Intersection Level of Service  
Worksheets

---

---

HCM 6th Signalized Intersection Summary  
 1: Old Redwood Hwy & Shiloh Road

Existing Conditions  
 Timing Plan: A.M. PEAK

												
Movement	EBL	EBT	EBR	WBL	WBT	WBR	NBL	NBT	NBR	SBL	SBT	SBR
Lane Configurations												
Traffic Volume (veh/h)	108	104	65	22	52	11	65	121	34	13	228	169
Future Volume (veh/h)	108	104	65	22	52	11	65	121	34	13	228	169
Initial Q (Qb), veh	0	0	0	0	0	0	0	0	0	0	0	0
Ped-Bike Adj(A_pbT)	1.00		1.00	1.00		1.00	1.00		1.00	1.00		0.98
Parking Bus, Adj	1.00	1.00	1.00	1.00	1.00	1.00	1.00	1.00	1.00	1.00	1.00	1.00
Work Zone On Approach		No			No			No			No	
Adj Sat Flow, veh/h/ln	1870	1870	1870	1870	1870	1870	1870	1870	1870	1870	1870	1870
Adj Flow Rate, veh/h	133	128	80	25	58	12	70	130	37	15	268	199
Peak Hour Factor	0.81	0.81	0.81	0.89	0.89	0.89	0.93	0.93	0.93	0.85	0.85	0.85
Percent Heavy Veh, %	2	2	2	2	2	2	2	2	2	2	2	2
Cap, veh/h	261	274	232	45	105	129	208	421	357	221	434	360
Arrive On Green	0.15	0.15	0.15	0.08	0.08	0.08	0.12	0.22	0.22	0.12	0.23	0.23
Sat Flow, veh/h	1781	1870	1585	555	1288	1585	1781	1870	1585	1781	1870	1551
Grp Volume(v), veh/h	133	128	80	83	0	12	70	130	37	15	268	199
Grp Sat Flow(s),veh/h/ln	1781	1870	1585	1843	0	1585	1781	1870	1585	1781	1870	1551
Q Serve(g_s), s	2.8	2.5	1.8	1.7	0.0	0.3	1.5	2.3	0.7	0.3	5.2	4.5
Cycle Q Clear(g_c), s	2.8	2.5	1.8	1.7	0.0	0.3	1.5	2.3	0.7	0.3	5.2	4.5
Prop In Lane	1.00		1.00	0.30		1.00	1.00		1.00	1.00		1.00
Lane Grp Cap(c), veh/h	261	274	232	150	0	129	208	421	357	221	434	360
V/C Ratio(X)	0.51	0.47	0.34	0.55	0.00	0.09	0.34	0.31	0.10	0.07	0.62	0.55
Avail Cap(c_a), veh/h	1352	1419	1203	1742	0	1499	643	2024	1715	266	1629	1350
HCM Platoon Ratio	1.00	1.00	1.00	1.00	1.00	1.00	1.00	1.00	1.00	1.00	1.00	1.00
Upstream Filter(I)	1.00	1.00	1.00	1.00	0.00	1.00	1.00	1.00	1.00	1.00	1.00	1.00
Uniform Delay (d), s/veh	15.8	15.7	15.4	17.8	0.0	17.1	16.3	13.0	12.4	15.5	13.8	13.6
Incr Delay (d2), s/veh	1.5	1.2	0.9	3.2	0.0	0.3	0.9	0.4	0.1	0.1	1.4	1.3
Initial Q Delay(d3),s/veh	0.0	0.0	0.0	0.0	0.0	0.0	0.0	0.0	0.0	0.0	0.0	0.0
%ile BackOfQ(50%),veh/ln	1.0	0.9	0.6	0.7	0.0	0.1	0.5	0.8	0.2	0.1	1.8	1.3
Unsig. Movement Delay, s/veh												
LnGrp Delay(d),s/veh	17.4	16.9	16.3	20.9	0.0	17.4	17.3	13.4	12.5	15.7	15.3	14.9
LnGrp LOS	B	B	B	C	A	B	B	B	B	B	B	B
Approach Vol, veh/h		341			95			237			482	
Approach Delay, s/veh		16.9			20.5			14.4			15.1	
Approach LOS		B			C			B			B	
Timer - Assigned Phs		2	3	4		6	7	8				
Phs Duration (G+Y+Rc), s		10.4	8.2	13.8		7.8	8.5	13.5				
Change Period (Y+Rc), s		4.5	3.5	4.5		4.5	3.5	4.5				
Max Green Setting (Gmax), s		30.5	14.5	35.0		38.0	6.0	43.5				
Max Q Clear Time (g_c+I1), s		4.8	3.5	7.2		3.7	2.3	4.3				
Green Ext Time (p_c), s		1.3	0.1	2.2		0.4	0.0	0.8				
<b>Intersection Summary</b>												
HCM 6th Ctrl Delay			16.0									
HCM 6th LOS			B									

HCM Signalized Intersection Capacity Analysis  
 2: Shiloh Road & Hembree Ln

Existing Conditions  
 Timing Plan: A.M. PEAK



Movement	EBL	EBT	WBT	WBR	SBL	SBR
Lane Configurations						
Traffic Volume (vph)	305	225	246	68	71	361
Future Volume (vph)	305	225	246	68	71	361
Ideal Flow (vphpl)	1900	1900	1900	1900	1900	1900
Total Lost time (s)	4.0	4.0	4.0		4.0	4.0
Lane Util. Factor	0.97	1.00	0.95		1.00	1.00
Frt	1.00	1.00	0.97		1.00	0.85
Flt Protected	0.95	1.00	1.00		0.95	1.00
Satd. Flow (prot)	3433	1863	3425		1770	1583
Flt Permitted	0.95	1.00	1.00		0.95	1.00
Satd. Flow (perm)	3433	1863	3425		1770	1583
Peak-hour factor, PHF	0.88	0.88	0.97	0.97	0.94	0.94
Adj. Flow (vph)	347	256	254	70	76	384
RTOR Reduction (vph)	0	0	37	0	0	231
Lane Group Flow (vph)	347	256	287	0	76	153
Turn Type	Prot	NA	NA		Perm	pm+ov
Protected Phases	5	2	6			5
Permitted Phases					4	4 5
Actuated Green, G (s)	10.3	24.0	9.7		4.0	14.3
Effective Green, g (s)	10.3	24.0	9.7		4.0	14.3
Actuated g/C Ratio	0.29	0.67	0.27		0.11	0.40
Clearance Time (s)	4.0	4.0	4.0		4.0	4.0
Vehicle Extension (s)	3.0	3.0	3.0		3.0	3.0
Lane Grp Cap (vph)	982	1242	922		196	804
v/s Ratio Prot	c0.10	0.14	c0.08			0.05
v/s Ratio Perm					c0.04	0.04
v/c Ratio	0.35	0.21	0.31		0.39	0.19
Uniform Delay, d1	10.2	2.3	10.5		14.9	7.1
Progression Factor	1.00	1.00	1.00		1.00	1.00
Incremental Delay, d2	0.2	0.1	0.2		1.3	0.1
Delay (s)	10.4	2.4	10.7		16.1	7.2
Level of Service	B	A	B		B	A
Approach Delay (s)		7.0	10.7		8.7	
Approach LOS		A	B		A	

Intersection Summary			
HCM 2000 Control Delay	8.4	HCM 2000 Level of Service	A
HCM 2000 Volume to Capacity ratio	0.34		
Actuated Cycle Length (s)	36.0	Sum of lost time (s)	12.0
Intersection Capacity Utilization	38.0%	ICU Level of Service	A
Analysis Period (min)	15		

c Critical Lane Group

HCM 6th Signalized Intersection Summary  
 3: US 101 NB Off-Ramp & Shiloh Road

Existing Conditions  
 Timing Plan: A.M. PEAK



Movement	EBT	EBR	WBL	WBT	NBL	NBR
Lane Configurations	↑↑			↑	↘	↗↗
Traffic Volume (veh/h)	218	0	0	484	432	325
Future Volume (veh/h)	218	0	0	484	432	325
Initial Q (Qb), veh	0	0	0	0	0	0
Ped-Bike Adj(A_pbT)		1.00	1.00		1.00	1.00
Parking Bus, Adj	1.00	1.00	1.00	1.00	1.00	1.00
Work Zone On Approach	No			No	No	
Adj Sat Flow, veh/h/ln	1870	0	0	1870	1870	1870
Adj Flow Rate, veh/h	240	0	0	538	568	428
Peak Hour Factor	0.91	0.91	0.90	0.90	0.76	0.76
Percent Heavy Veh, %	2	0	0	2	2	2
Cap, veh/h	1355	0	0	713	742	1162
Arrive On Green	0.38	0.00	0.00	0.38	0.42	0.42
Sat Flow, veh/h	3741	0	0	1870	1781	2790
Grp Volume(v), veh/h	240	0	0	538	568	428
Grp Sat Flow(s),veh/h/ln	1777	0	0	1870	1781	1395
Q Serve(g_s), s	1.8	0.0	0.0	9.9	10.8	4.2
Cycle Q Clear(g_c), s	1.8	0.0	0.0	9.9	10.8	4.2
Prop In Lane		0.00	0.00		1.00	1.00
Lane Grp Cap(c), veh/h	1355	0	0	713	742	1162
V/C Ratio(X)	0.18	0.00	0.00	0.75	0.77	0.37
Avail Cap(c_a), veh/h	2962	0	0	1559	1395	2184
HCM Platoon Ratio	1.00	1.00	1.00	1.00	1.00	1.00
Upstream Filter(I)	1.00	0.00	0.00	1.00	1.00	1.00
Uniform Delay (d), s/veh	8.1	0.0	0.0	10.6	9.9	8.0
Incr Delay (d2), s/veh	0.1	0.0	0.0	1.6	1.7	0.2
Initial Q Delay(d3),s/veh	0.0	0.0	0.0	0.0	0.0	0.0
%ile BackOfQ(50%),veh/ln	0.5	0.0	0.0	2.9	3.3	0.9
Unsig. Movement Delay, s/veh						
LnGrp Delay(d),s/veh	8.2	0.0	0.0	12.3	11.6	8.2
LnGrp LOS	A	A	A	B	B	A
Approach Vol, veh/h	240			538	996	
Approach Delay, s/veh	8.2			12.3	10.1	
Approach LOS	A			B	B	
Timer - Assigned Phs		2			6	8
Phs Duration (G+Y+Rc), s		19.1			19.1	20.5
Change Period (Y+Rc), s		4.0			4.0	4.0
Max Green Setting (Gmax), s		33.0			33.0	31.0
Max Q Clear Time (g_c+I1), s		3.8			11.9	12.8
Green Ext Time (p_c), s		1.4			3.2	3.7
<b>Intersection Summary</b>						
HCM 6th Ctrl Delay			10.5			
HCM 6th LOS			B			

HCM Signalized Intersection Capacity Analysis  
4: Shiloh Road & US 101 SB Off-Ramp

Existing Conditions  
Timing Plan: A.M. PEAK



Movement	EBL	EBT	WBT	WBR	SBL	SBR
Lane Configurations		↑	↑		↙	↗
Traffic Volume (vph)	0	226	584	0	80	138
Future Volume (vph)	0	226	584	0	80	138
Ideal Flow (vphpl)	1900	1900	1900	1900	1900	1900
Total Lost time (s)		4.0	4.0		4.0	4.0
Lane Util. Factor		1.00	1.00		1.00	1.00
Frt		1.00	1.00		1.00	0.85
Flt Protected		1.00	1.00		0.95	1.00
Satd. Flow (prot)		1863	1863		1770	1583
Flt Permitted		1.00	1.00		0.95	1.00
Satd. Flow (perm)		1863	1863		1770	1583
Peak-hour factor, PHF	0.93	0.93	0.91	0.91	0.92	0.92
Adj. Flow (vph)	0	243	642	0	87	150
RTOR Reduction (vph)	0	0	0	0	0	124
Lane Group Flow (vph)	0	243	642	0	87	26
Turn Type		NA	NA		Perm	Perm
Protected Phases		2	6			
Permitted Phases					4	4
Actuated Green, G (s)		18.4	18.4		5.5	5.5
Effective Green, g (s)		18.4	18.4		5.5	5.5
Actuated g/C Ratio		0.58	0.58		0.17	0.17
Clearance Time (s)		4.0	4.0		4.0	4.0
Vehicle Extension (s)		3.0	3.0		3.0	3.0
Lane Grp Cap (vph)		1074	1074		305	272
v/s Ratio Prot		0.13	c0.34			
v/s Ratio Perm					c0.05	0.02
v/c Ratio		0.23	0.60		0.29	0.10
Uniform Delay, d1		3.3	4.4		11.5	11.1
Progression Factor		1.00	1.00		1.00	1.00
Incremental Delay, d2		0.1	0.9		0.5	0.2
Delay (s)		3.4	5.3		12.0	11.3
Level of Service		A	A		B	B
Approach Delay (s)		3.4	5.3		11.5	
Approach LOS		A	A		B	

Intersection Summary			
HCM 2000 Control Delay	6.2	HCM 2000 Level of Service	A
HCM 2000 Volume to Capacity ratio	0.53		
Actuated Cycle Length (s)	31.9	Sum of lost time (s)	8.0
Intersection Capacity Utilization	54.2%	ICU Level of Service	A
Analysis Period (min)	15		

c Critical Lane Group



HCM 6th TWSC  
5: Caletti Ave & Shiloh Road

Existing Conditions  
Timing Plan: A.M. PEAK

Intersection						
Int Delay, s/veh	2.6					
Movement	EBT	EBR	WBL	WBT	NBL	NBR
Lane Configurations	↑↑		↘	↑	↘	↘
Traffic Vol, veh/h	518	22	177	547	7	121
Future Vol, veh/h	518	22	177	547	7	121
Conflicting Peds, #/hr	0	0	0	0	0	0
Sign Control	Free	Free	Free	Free	Stop	Stop
RT Channelized	-	None	-	None	-	None
Storage Length	-	-	68	-	0	0
Veh in Median Storage, #	0	-	-	0	0	-
Grade, %	0	-	-	0	0	-
Peak Hour Factor	96	96	87	87	84	84
Heavy Vehicles, %	2	2	2	2	2	2
Mvmt Flow	540	23	203	629	8	144



















Major/Minor	Major1	Major2	Minor1		
Conflicting Flow All	0	0	563	0	1587 282
Stage 1	-	-	-	-	552 -
Stage 2	-	-	-	-	1035 -
Critical Hdwy	-	-	4.13	-	6.63 6.93
Critical Hdwy Stg 1	-	-	-	-	5.83 -
Critical Hdwy Stg 2	-	-	-	-	5.43 -
Follow-up Hdwy	-	-	2.219	-	3.519 3.319
Pot Cap-1 Maneuver	-	-	1007	-	108 716
Stage 1	-	-	-	-	541 -
Stage 2	-	-	-	-	341 -
Platoon blocked, %	-	-	-	-	-
Mov Cap-1 Maneuver	-	-	1007	-	86 716
Mov Cap-2 Maneuver	-	-	-	-	86 -
Stage 1	-	-	-	-	541 -
Stage 2	-	-	-	-	272 -

Approach	EB	WB	NB
HCM Control Delay, s	0	2.3	13.5
HCM LOS			B

Minor Lane/Major Mvmt	NBLn1	NBLn2	EBT	EBR	WBL	WBT
Capacity (veh/h)	86	716	-	-	1007	-
HCM Lane V/C Ratio	0.097	0.201	-	-	0.202	-
HCM Control Delay (s)	51.3	11.3	-	-	9.5	-
HCM Lane LOS	F	B	-	-	A	-
HCM 95th %tile Q(veh)	0.3	0.7	-	-	0.8	-

HCM Signalized Intersection Capacity Analysis  
6: Conde Lane & Shiloh Road

Existing Conditions  
Timing Plan: A.M. PEAK

													
Movement	EBL	EBT	EBR	WBL	WBT	WBR	NBL	NBT	NBR	SBL	SBT	SBR	
Lane Configurations													
Traffic Volume (vph)	25	323	5	9	351	204	4	0	12	205	1	35	
Future Volume (vph)	25	323	5	9	351	204	4	0	12	205	1	35	
Ideal Flow (vphpl)	1900	1900	1900	1900	1900	1900	1900	1900	1900	1900	1900	1900	
Total Lost time (s)	4.0	4.0		4.0	4.0			4.0			4.0	4.0	
Lane Util. Factor	1.00	0.95		1.00	0.95			1.00			1.00	1.00	
Frt	1.00	1.00		1.00	0.94			0.90			1.00	0.85	
Flt Protected	0.95	1.00		0.95	1.00			0.99			0.95	1.00	
Satd. Flow (prot)	1770	3532		1770	3344			1653			1774	1583	
Flt Permitted	0.95	1.00		0.95	1.00			0.99			0.95	1.00	
Satd. Flow (perm)	1770	3532		1770	3344			1653			1774	1583	
Peak-hour factor, PHF	0.95	0.95	0.95	0.85	0.85	0.85	0.57	0.57	0.57	0.86	0.86	0.86	
Adj. Flow (vph)	26	340	5	11	413	240	7	0	21	238	1	41	
RTOR Reduction (vph)	0	1	0	0	83	0	0	26	0	0	0	0	
Lane Group Flow (vph)	26	344	0	11	570	0	0	2	0	0	239	41	
Turn Type	Prot	NA		Prot	NA		Split	NA		Split	NA	custom	
Protected Phases	5	2		1	6		7	7		4	4		
Permitted Phases												6	
Actuated Green, G (s)	2.1	16.3		1.0	15.2			2.7			12.8	15.2	
Effective Green, g (s)	2.1	16.3		1.0	15.2			2.7			12.8	15.2	
Actuated g/C Ratio	0.04	0.33		0.02	0.31			0.06			0.26	0.31	
Clearance Time (s)	4.0	4.0		4.0	4.0			4.0			4.0	4.0	
Vehicle Extension (s)	3.0	3.0		3.0	3.0			3.0			3.0	3.0	
Lane Grp Cap (vph)	76	1179		36	1041			91			465	493	
v/s Ratio Prot	c0.01	0.10		0.01	c0.17			c0.00			c0.13		
v/s Ratio Perm												0.03	
v/c Ratio	0.34	0.29		0.31	0.55			0.02			0.51	0.08	
Uniform Delay, d1	22.7	12.0		23.6	13.9			21.8			15.3	11.9	
Progression Factor	1.00	1.00		1.00	1.00			1.00			1.00	1.00	
Incremental Delay, d2	2.7	0.1		4.8	0.6			0.1			1.0	0.1	
Delay (s)	25.4	12.1		28.3	14.5			21.9			16.3	11.9	
Level of Service	C	B		C	B			C			B	B	
Approach Delay (s)		13.1			14.8			21.9			15.7		
Approach LOS		B			B			C			B		
<b>Intersection Summary</b>													
HCM 2000 Control Delay			14.6									HCM 2000 Level of Service	B
HCM 2000 Volume to Capacity ratio			0.48										
Actuated Cycle Length (s)			48.8									Sum of lost time (s)	16.0
Intersection Capacity Utilization			45.5%									ICU Level of Service	A
Analysis Period (min)			15										

c Critical Lane Group

HCM 6th TWSC  
7: Entrance 1/Gridley Drive & Shiloh Road

Existing Conditions  
Timing Plan: A.M. PEAK

Intersection												
Int Delay, s/veh	1.1											
Movement	EBL	EBT	EBR	WBL	WBT	WBR	NBL	NBT	NBR	SBL	SBT	SBR
Lane Configurations		↕			↕		↕	↕			↕	
Traffic Vol, veh/h	8	141	0	0	58	0	0	0	0	1	0	16
Future Vol, veh/h	8	141	0	0	58	0	0	0	0	1	0	16
Conflicting Peds, #/hr	0	0	0	0	0	0	0	0	0	0	0	0
Sign Control	Free	Free	Free	Free	Free	Free	Stop	Stop	Stop	Stop	Stop	Stop
RT Channelized	-	-	None	-	-	None	-	-	None	-	-	None
Storage Length	-	-	-	-	-	-	0	-	-	-	-	-
Veh in Median Storage, #	-	0	-	-	0	-	-	0	-	-	0	-
Grade, %	-	0	-	-	0	-	-	0	-	-	0	-
Peak Hour Factor	91	91	91	85	85	85	100	100	100	71	71	71
Heavy Vehicles, %	2	2	2	2	2	2	2	2	2	2	2	2
Mvmt Flow	9	155	0	0	68	0	0	0	0	1	0	23

Major/Minor	Major1			Major2			Minor1			Minor2		
Conflicting Flow All	68	0	0	155	0	0	253	241	155	241	241	68
Stage 1	-	-	-	-	-	-	173	173	-	68	68	-
Stage 2	-	-	-	-	-	-	80	68	-	173	173	-
Critical Hdwy	4.12	-	-	4.12	-	-	7.12	6.52	6.22	7.12	6.52	6.22
Critical Hdwy Stg 1	-	-	-	-	-	-	6.12	5.52	-	6.12	5.52	-
Critical Hdwy Stg 2	-	-	-	-	-	-	6.12	5.52	-	6.12	5.52	-
Follow-up Hdwy	2.218	-	-	2.218	-	-	3.518	4.018	3.318	3.518	4.018	3.318
Pot Cap-1 Maneuver	1533	-	-	1425	-	-	700	660	891	713	660	995
Stage 1	-	-	-	-	-	-	829	756	-	942	838	-
Stage 2	-	-	-	-	-	-	929	838	-	829	756	-
Platoon blocked, %	-	-	-	-	-	-	-	-	-	-	-	-
Mov Cap-1 Maneuver	1533	-	-	1425	-	-	681	656	891	709	656	995
Mov Cap-2 Maneuver	-	-	-	-	-	-	681	656	-	709	656	-
Stage 1	-	-	-	-	-	-	824	751	-	936	838	-
Stage 2	-	-	-	-	-	-	908	838	-	824	751	-

Approach	EB	WB	NB	SB
HCM Control Delay, s	0.4	0	0	8.8
HCM LOS			A	A

Minor Lane/Major Mvmt	NBLn1	NBLn2	EBL	EBT	EBR	WBL	WBT	WBR	SBLn1
Capacity (veh/h)	-	-	1533	-	-	1425	-	-	972
HCM Lane V/C Ratio	-	-	0.006	-	-	-	-	-	0.025
HCM Control Delay (s)	0	0	7.4	0	-	0	-	-	8.8
HCM Lane LOS	A	A	A	A	-	A	-	-	A
HCM 95th %tile Q(veh)	-	-	0	-	-	0	-	-	0.1

HCM 6th TWSC  
8: Old Redwood Hwy & Entrance 1

Existing Conditions  
Timing Plan: A.M. PEAK

Intersection												
Int Delay, s/veh	0.1											
Movement	EBL	EBT	EBR	WBL	WBT	WBR	NBL	NBT	NBR	SBL	SBT	SBR
Lane Configurations		↕		↕	↕			↕		↕	↕	
Traffic Vol, veh/h	1	0	0	0	0	0	0	217	0	0	316	0
Future Vol, veh/h	1	0	0	0	0	0	0	217	0	0	316	0
Conflicting Peds, #/hr	0	0	0	0	0	0	0	0	1	1	0	0
Sign Control	Stop	Stop	Stop	Stop	Stop	Stop	Free	Free	Free	Free	Free	Free
RT Channelized	-	-	None	-	-	None	-	-	None	-	-	None
Storage Length	-	-	-	0	-	-	-	-	-	50	-	-
Veh in Median Storage, #	-	0	-	-	0	-	-	0	-	-	0	-
Grade, %	-	0	-	-	0	-	-	0	-	-	0	-
Peak Hour Factor	25	25	25	100	100	100	99	99	99	90	90	90
Heavy Vehicles, %	2	2	2	2	2	2	2	2	2	2	2	2
Mvmt Flow	4	0	0	0	0	0	0	219	0	0	351	0

Major/Minor	Minor2		Minor1		Major1		Major2					
Conflicting Flow All	570	571	351	571	571	220	351	0	0	220	0	0
Stage 1	351	351	-	220	220	-	-	-	-	-	-	-
Stage 2	219	220	-	351	351	-	-	-	-	-	-	-
Critical Hdwy	7.12	6.52	6.22	7.12	6.52	6.22	4.12	-	-	4.12	-	-
Critical Hdwy Stg 1	6.12	5.52	-	6.12	5.52	-	-	-	-	-	-	-
Critical Hdwy Stg 2	6.12	5.52	-	6.12	5.52	-	-	-	-	-	-	-
Follow-up Hdwy	3.518	4.018	3.318	3.518	4.018	3.318	2.218	-	-	2.218	-	-
Pot Cap-1 Maneuver	432	431	692	432	431	820	1208	-	-	1349	-	-
Stage 1	666	632	-	782	721	-	-	-	-	-	-	-
Stage 2	783	721	-	666	632	-	-	-	-	-	-	-
Platoon blocked, %								-	-	-	-	-
Mov Cap-1 Maneuver	432	431	692	432	431	819	1208	-	-	1348	-	-
Mov Cap-2 Maneuver	432	431	-	432	431	-	-	-	-	-	-	-
Stage 1	666	632	-	781	720	-	-	-	-	-	-	-
Stage 2	783	720	-	666	632	-	-	-	-	-	-	-

Approach	EB	WB	NB	SB
HCM Control Delay, s	13.4	0	0	0
HCM LOS	B	A		

Minor Lane/Major Mvmt	NBL	NBT	NBR	EBLn1	WBLn1	WBLn2	SBL	SBT	SBR
Capacity (veh/h)	1208	-	-	432	-	-	1348	-	-
HCM Lane V/C Ratio	-	-	-	0.009	-	-	-	-	-
HCM Control Delay (s)	0	-	-	13.4	0	0	0	-	-
HCM Lane LOS	A	-	-	B	A	A	A	-	-
HCM 95th %tile Q(veh)	0	-	-	0	-	-	0	-	-

Intersection						
Int Delay, s/veh	0					
Movement	EBT	EBR	WBL	WBT	NBL	NBR
Lane Configurations	↔			↔	↔	↔
Traffic Vol, veh/h	140	0	0	52	0	0
Future Vol, veh/h	140	0	0	52	0	0
Conflicting Peds, #/hr	0	0	0	0	0	0
Sign Control	Free	Free	Free	Free	Stop	Stop
RT Channelized	-	None	-	None	-	None
Storage Length	-	-	-	-	0	0
Veh in Median Storage, #	0	-	-	0	0	-
Grade, %	0	-	-	0	0	-
Peak Hour Factor	85	85	81	81	100	100
Heavy Vehicles, %	2	2	2	2	2	2
Mvmt Flow	165	0	0	64	0	0

Major/Minor	Major1	Major2	Minor1			
Conflicting Flow All	0	0	165	0	229	165
Stage 1	-	-	-	-	165	-
Stage 2	-	-	-	-	64	-
Critical Hdwy	-	-	4.12	-	6.42	6.22
Critical Hdwy Stg 1	-	-	-	-	5.42	-
Critical Hdwy Stg 2	-	-	-	-	5.42	-
Follow-up Hdwy	-	-	2.218	-	3.518	3.318
Pot Cap-1 Maneuver	-	-	1413	-	759	879
Stage 1	-	-	-	-	864	-
Stage 2	-	-	-	-	959	-
Platoon blocked, %	-	-	-	-	-	-
Mov Cap-1 Maneuver	-	-	1413	-	759	879
Mov Cap-2 Maneuver	-	-	-	-	759	-
Stage 1	-	-	-	-	864	-
Stage 2	-	-	-	-	959	-

Approach	EB	WB	NB
HCM Control Delay, s	0	0	0
HCM LOS			A

Minor Lane/Major Mvmt	NBLn1	NBLn2	EBT	EBR	WBL	WBT
Capacity (veh/h)	-	-	-	-	1413	-
HCM Lane V/C Ratio	-	-	-	-	-	-
HCM Control Delay (s)	0	0	-	-	0	-
HCM Lane LOS	A	A	-	-	A	-
HCM 95th %tile Q(veh)	-	-	-	-	0	-

HCM 6th Signalized Intersection Summary  
 10: US 101 NB Off Ramp/Lakewood Drive & Old Redwood Highway

Existing Conditions  
 Timing Plan: A.M. PEAK



Movement	EBL	EBT	EBR	WBL	WBT	WBR	NBL	NBT	NBR	SBL	SBT	SBR
Lane Configurations	↗↘	↑			↑↑		↗	↔		↗↘		↗
Traffic Volume (veh/h)	152	149	0	0	440	149	227	221	79	118	0	534
Future Volume (veh/h)	152	149	0	0	440	149	227	221	79	118	0	534
Initial Q (Qb), veh	0	0	0	0	0	0	0	0	0	0	0	0
Ped-Bike Adj(A_pbT)	1.00		1.00	1.00		0.99	1.00		1.00	1.00		1.00
Parking Bus, Adj	1.00	1.00	1.00	1.00	1.00	1.00	1.00	1.00	1.00	1.00	1.00	1.00
Work Zone On Approach		No			No			No			No	
Adj Sat Flow, veh/h/ln	1870	1870	0	0	1870	1870	1870	1870	1870	1870	0	1870
Adj Flow Rate, veh/h	179	175	0	0	530	180	195	325	88	133	0	0
Peak Hour Factor	0.85	0.85	0.85	0.83	0.83	0.83	0.90	0.90	0.90	0.89	0.89	0.89
Percent Heavy Veh, %	2	2	0	0	2	2	2	2	2	2	0	2
Cap, veh/h	373	1215	0	0	1239	419	342	546	145	0	0	
Arrive On Green	0.11	0.65	0.00	0.00	0.48	0.48	0.19	0.19	0.19	0.00	0.00	0.00
Sat Flow, veh/h	3456	1870	0	0	2691	878	1781	2844	758		0	
Grp Volume(v), veh/h	179	175	0	0	362	348	195	212	201		0.0	
Grp Sat Flow(s),veh/h/ln	1728	1870	0	0	1777	1699	1781	1870	1731			
Q Serve(g_s), s	3.0	2.2	0.0	0.0	8.3	8.3	6.1	6.4	6.6			
Cycle Q Clear(g_c), s	3.0	2.2	0.0	0.0	8.3	8.3	6.1	6.4	6.6			
Prop In Lane	1.00		0.00	0.00		0.52	1.00		0.44			
Lane Grp Cap(c), veh/h	373	1215	0	0	848	810	342	359	332			
V/C Ratio(X)	0.48	0.14	0.00	0.00	0.43	0.43	0.57	0.59	0.61			
Avail Cap(c_a), veh/h	503	1215	0	0	848	810	835	877	811			
HCM Platoon Ratio	1.00	1.00	1.00	1.00	1.00	1.00	1.00	1.00	1.00			
Upstream Filter(I)	1.00	1.00	0.00	0.00	1.00	1.00	1.00	1.00	1.00			
Uniform Delay (d), s/veh	26.0	4.2	0.0	0.0	10.6	10.6	22.7	22.8	22.9			
Incr Delay (d2), s/veh	1.0	0.2	0.0	0.0	1.6	1.7	1.5	1.5	1.8			
Initial Q Delay(d3),s/veh	0.0	0.0	0.0	0.0	0.0	0.0	0.0	0.0	0.0			
%ile BackOfQ(50%),veh/ln	1.2	0.6	0.0	0.0	3.0	2.9	2.5	2.8	2.7			
Unsig. Movement Delay, s/veh												
LnGrp Delay(d),s/veh	26.9	4.4	0.0	0.0	12.2	12.3	24.2	24.3	24.6			
LnGrp LOS	C	A	A	A	B	B	C	C	C			
Approach Vol, veh/h		354			710			608				
Approach Delay, s/veh		15.8			12.2			24.4				
Approach LOS		B			B			C				
Timer - Assigned Phs		2			5	6		8				
Phs Duration (G+Y+Rc), s		45.3			10.7	34.6		16.6				
Change Period (Y+Rc), s		5.1			4.0	5.1		4.7				
Max Green Setting (Gmax), s		40.2			9.0	27.2		29.0				
Max Q Clear Time (g_c+I1), s		4.2			5.0	10.3		8.6				
Green Ext Time (p_c), s		1.0			0.2	4.1		3.0				

Intersection Summary

HCM 6th Ctrl Delay	17.4
HCM 6th LOS	B

Notes

User approved volume balancing among the lanes for turning movement.  
 Unsignalized Delay for [SBR] is excluded from calculations of the approach delay and intersection delay.

HCM 6th Signalized Intersection Summary  
 12: US 101 SB On Ramp/US 101 SB Off Ramp & Old Redwood Highway

Existing Conditions  
 Timing Plan: A.M. PEAK



Movement	EBL	EBT	EBR	WBL	WBT	WBR	NBL	NBT	NBR	SBL	SBT	SBR
Lane Configurations		↑↑	↗	↘	↑↑					↘	↕	
Traffic Volume (veh/h)	0	298	296	513	504	0	0	0	0	92	1	65
Future Volume (veh/h)	0	298	296	513	504	0	0	0	0	92	1	65
Initial Q (Qb), veh	0	0	0	0	0	0				0	0	0
Ped-Bike Adj(A_pbT)	1.00		0.98	1.00		1.00				1.00		1.00
Parking Bus, Adj	1.00	1.00	1.00	1.00	1.00	1.00				1.00	1.00	1.00
Work Zone On Approach		No			No						No	
Adj Sat Flow, veh/h/ln	0	1870	1870	1870	1870	0				1870	1870	1870
Adj Flow Rate, veh/h	0	324	322	576	566	0				98	24	0
Peak Hour Factor	0.92	0.92	0.92	0.89	0.89	0.89				0.81	0.81	0.81
Percent Heavy Veh, %	0	2	2	2	2	0				2	2	2
Cap, veh/h	0	1293	568	614	2697	0				209	220	
Arrive On Green	0.00	0.36	0.36	0.34	0.76	0.00				0.12	0.12	0.00
Sat Flow, veh/h	0	3647	1560	1781	3647	0				1781	1870	0
Grp Volume(v), veh/h	0	324	322	576	566	0				98	24	0
Grp Sat Flow(s),veh/h/ln	0	1777	1560	1781	1777	0				1781	1870	0
Q Serve(g_s), s	0.0	5.1	13.1	24.8	3.6	0.0				4.1	0.9	0.0
Cycle Q Clear(g_c), s	0.0	5.1	13.1	24.8	3.6	0.0				4.1	0.9	0.0
Prop In Lane	0.00		1.00	1.00		0.00				1.00		0.00
Lane Grp Cap(c), veh/h	0	1293	568	614	2697	0				209	220	
V/C Ratio(X)	0.00	0.25	0.57	0.94	0.21	0.00				0.47	0.11	
Avail Cap(c_a), veh/h	0	1293	568	651	2697	0				225	236	
HCM Platoon Ratio	1.00	1.00	1.00	1.00	1.00	1.00				1.00	1.00	1.00
Upstream Filter(I)	0.00	1.00	1.00	1.00	1.00	0.00				1.00	1.00	0.00
Uniform Delay (d), s/veh	0.0	17.7	20.2	25.2	2.7	0.0				32.7	31.3	0.0
Incr Delay (d2), s/veh	0.0	0.5	4.1	20.8	0.2	0.0				1.6	0.2	0.0
Initial Q Delay(d3),s/veh	0.0	0.0	0.0	0.0	0.0	0.0				0.0	0.0	0.0
%ile BackOfQ(50%),veh/ln	0.0	2.0	5.1	13.2	0.8	0.0				1.8	0.4	0.0
Unsig. Movement Delay, s/veh												
LnGrp Delay(d),s/veh	0.0	18.1	24.3	46.0	2.9	0.0				34.3	31.5	0.0
LnGrp LOS	A	B	C	D	A	A				C	C	
Approach Vol, veh/h		646			1142						122	
Approach Delay, s/veh		21.2			24.6						33.8	
Approach LOS		C			C						C	
Timer - Assigned Phs		2			5	6		8				
Phs Duration (G+Y+Rc), s		65.3			31.3	34.0		14.0				
Change Period (Y+Rc), s		5.1			4.0	5.1		4.7				
Max Green Setting (Gmax), s		60.2			29.0	27.2		10.0				
Max Q Clear Time (g_c+I1), s		5.6			26.8	15.1		6.1				
Green Ext Time (p_c), s		4.2			0.5	2.6		0.1				

Intersection Summary























HCM 6th Ctrl Delay	24.1
HCM 6th LOS	C

Notes

- User approved volume balancing among the lanes for turning movement.
- User approved ignoring U-Turning movement.
- Unsignalized Delay for [SBR] is excluded from calculations of the approach delay and intersection delay.

HCM 6th Signalized Intersection Summary  
 1: Old Redwood Hwy & Shiloh Road

Existing Conditions  
 Timing Plan: P.M. Peak

												
Movement	EBL	EBT	EBR	WBL	WBT	WBR	NBL	NBT	NBR	SBL	SBT	SBR
Lane Configurations												
Traffic Volume (veh/h)	241	83	160	37	78	16	140	337	21	23	233	146
Future Volume (veh/h)	241	83	160	37	78	16	140	337	21	23	233	146
Initial Q (Qb), veh	0	0	0	0	0	0	0	0	0	0	0	0
Ped-Bike Adj(A_pbT)	1.00		1.00	1.00		1.00	1.00		0.97	1.00		0.97
Parking Bus, Adj	1.00	1.00	1.00	1.00	1.00	1.00	1.00	1.00	1.00	1.00	1.00	1.00
Work Zone On Approach		No			No			No			No	
Adj Sat Flow, veh/h/ln	1870	1870	1870	1870	1870	1870	1870	1870	1870	1870	1870	1870
Adj Flow Rate, veh/h	248	86	165	41	86	18	151	362	23	25	251	157
Peak Hour Factor	0.97	0.97	0.97	0.91	0.91	0.91	0.93	0.93	0.93	0.93	0.93	0.93
Percent Heavy Veh, %	2	2	2	2	2	2	2	2	2	2	2	2
Cap, veh/h	360	378	320	64	135	171	221	494	408	172	443	366
Arrive On Green	0.20	0.20	0.20	0.11	0.11	0.11	0.12	0.26	0.26	0.10	0.24	0.24
Sat Flow, veh/h	1781	1870	1581	594	1246	1578	1781	1870	1544	1781	1870	1543
Grp Volume(v), veh/h	248	86	165	127	0	18	151	362	23	25	251	157
Grp Sat Flow(s),veh/h/ln	1781	1870	1581	1841	0	1578	1781	1870	1544	1781	1870	1543
Q Serve(g_s), s	6.7	2.0	4.8	3.4	0.0	0.5	4.2	9.1	0.6	0.7	6.1	4.5
Cycle Q Clear(g_c), s	6.7	2.0	4.8	3.4	0.0	0.5	4.2	9.1	0.6	0.7	6.1	4.5
Prop In Lane	1.00		1.00	0.32		1.00	1.00		1.00	1.00		1.00
Lane Grp Cap(c), veh/h	360	378	320	199	0	171	221	494	408	172	443	366
V/C Ratio(X)	0.69	0.23	0.52	0.64	0.00	0.11	0.68	0.73	0.06	0.15	0.57	0.43
Avail Cap(c_a), veh/h	1050	1103	932	1352	0	1159	499	1573	1298	207	1265	1044
HCM Platoon Ratio	1.00	1.00	1.00	1.00	1.00	1.00	1.00	1.00	1.00	1.00	1.00	1.00
Upstream Filter(I)	1.00	1.00	1.00	1.00	0.00	1.00	1.00	1.00	1.00	1.00	1.00	1.00
Uniform Delay (d), s/veh	19.1	17.3	18.4	22.1	0.0	20.8	21.7	17.4	14.2	21.4	17.4	16.8
Incr Delay (d2), s/veh	2.3	0.3	1.3	3.4	0.0	0.3	3.7	2.1	0.1	0.4	1.1	0.8
Initial Q Delay(d3),s/veh	0.0	0.0	0.0	0.0	0.0	0.0	0.0	0.0	0.0	0.0	0.0	0.0
%ile BackOfQ(50%),veh/ln	2.6	0.8	1.6	1.5	0.0	0.2	1.7	3.4	0.2	0.3	2.3	1.4
Unsig. Movement Delay, s/veh												
LnGrp Delay(d),s/veh	21.5	17.6	19.7	25.5	0.0	21.1	25.4	19.5	14.3	21.8	18.5	17.6
LnGrp LOS	C	B	B	C	A	C	C	B	B	C	B	B
Approach Vol, veh/h		499			145			536			433	
Approach Delay, s/veh		20.2			24.9			20.9			18.4	
Approach LOS		C			C			C			B	
Timer - Assigned Phs		2	3	4		6	7	8				
Phs Duration (G+Y+Rc), s		15.0	9.9	16.8		10.1	8.5	18.2				
Change Period (Y+Rc), s		4.5	3.5	4.5		4.5	3.5	4.5				
Max Green Setting (Gmax), s		30.5	14.5	35.0		38.0	6.0	43.5				
Max Q Clear Time (g_c+I1), s		8.7	6.2	8.1		5.4	2.7	11.1				
Green Ext Time (p_c), s		1.7	0.2	1.9		0.7	0.0	2.1				
<b>Intersection Summary</b>												
HCM 6th Ctrl Delay				20.4								
HCM 6th LOS				C								



# HCM Signalized Intersection Capacity Analysis

## 2: Shiloh Road & Hembree Ln

Existing Conditions  
Timing Plan: P.M. Peak



Movement	EBL	EBT	WBT	WBR	SBL	SBR
Lane Configurations	←↑→	↑	←↑→		←↑→	←↑→
Traffic Volume (vph)	615	333	248	141	170	491
Future Volume (vph)	615	333	248	141	170	491
Ideal Flow (vphpl)	1900	1900	1900	1900	1900	1900
Total Lost time (s)	4.0	4.0	4.0		4.0	4.0
Lane Util. Factor	0.97	1.00	0.95		1.00	1.00
Frpb, ped/bikes	1.00	1.00	1.00		1.00	1.00
Flpb, ped/bikes	1.00	1.00	1.00		1.00	1.00
Frt	1.00	1.00	0.95		1.00	0.85
Flt Protected	0.95	1.00	1.00		0.95	1.00
Satd. Flow (prot)	3433	1863	3331		1770	1583
Flt Permitted	0.95	1.00	1.00		0.95	1.00
Satd. Flow (perm)	3433	1863	3331		1770	1583
Peak-hour factor, PHF	0.94	0.94	0.87	0.87	0.95	0.95
Adj. Flow (vph)	654	354	285	162	179	517
RTOR Reduction (vph)	0	0	126	0	0	213
Lane Group Flow (vph)	654	354	321	0	179	304
Confl. Peds. (#/hr)	2			2		
Turn Type	Prot	NA	NA		Perm	pm+ov
Protected Phases	5	2	6			5
Permitted Phases					4	4 5
Actuated Green, G (s)	16.6	31.4	10.8		10.9	27.5
Effective Green, g (s)	16.6	31.4	10.8		10.9	27.5
Actuated g/C Ratio	0.33	0.62	0.21		0.22	0.55
Clearance Time (s)	4.0	4.0	4.0		4.0	4.0
Vehicle Extension (s)	3.0	3.0	3.0		3.0	3.0
Lane Grp Cap (vph)	1132	1162	715		383	991
v/s Ratio Prot	c0.19	0.19	c0.10			0.10
v/s Ratio Perm					c0.10	0.09
v/c Ratio	0.58	0.30	0.45		0.47	0.31
Uniform Delay, d1	13.9	4.4	17.2		17.2	6.2
Progression Factor	1.00	1.00	1.00		1.00	1.00
Incremental Delay, d2	0.7	0.1	0.5		0.9	0.2
Delay (s)	14.7	4.5	17.6		18.1	6.4
Level of Service	B	A	B		B	A
Approach Delay (s)		11.1	17.6		9.4	
Approach LOS		B	B		A	
<b>Intersection Summary</b>						
HCM 2000 Control Delay			11.9		HCM 2000 Level of Service	B
HCM 2000 Volume to Capacity ratio			0.51			
Actuated Cycle Length (s)			50.3		Sum of lost time (s)	12.0
Intersection Capacity Utilization			49.9%		ICU Level of Service	A
Analysis Period (min)			15			
c Critical Lane Group						

HCM 6th Signalized Intersection Summary  
 3: US 101 NB Off-Ramp & Shiloh Road

Existing Conditions  
 Timing Plan: P.M. Peak

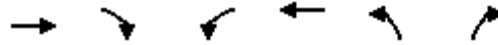

Movement	EBT	EBR	WBL	WBT	NBL	NBR
Lane Configurations	↑↑			↑	↘	↗↗
Traffic Volume (veh/h)	348	0	0	514	526	605
Future Volume (veh/h)	348	0	0	514	526	605
Initial Q (Qb), veh	0	0	0	0	0	0
Ped-Bike Adj(A_pbT)		1.00	1.00		1.00	1.00
Parking Bus, Adj	1.00	1.00	1.00	1.00	1.00	1.00
Work Zone On Approach	No			No	No	
Adj Sat Flow, veh/h/ln	1870	0	0	1870	1870	1870
Adj Flow Rate, veh/h	370	0	0	530	584	672
Peak Hour Factor	0.94	0.94	0.97	0.97	0.90	0.90
Percent Heavy Veh, %	2	0	0	2	2	2
Cap, veh/h	1318	0	0	694	781	1223
Arrive On Green	0.37	0.00	0.00	0.37	0.44	0.44
Sat Flow, veh/h	3741	0	0	1870	1781	2790
Grp Volume(v), veh/h	370	0	0	530	584	672
Grp Sat Flow(s),veh/h/ln	1777	0	0	1870	1781	1395
Q Serve(g_s), s	3.1	0.0	0.0	10.4	11.5	7.5
Cycle Q Clear(g_c), s	3.1	0.0	0.0	10.4	11.5	7.5
Prop In Lane		0.00	0.00		1.00	1.00
Lane Grp Cap(c), veh/h	1318	0	0	694	781	1223
V/C Ratio(X)	0.28	0.00	0.00	0.76	0.75	0.55
Avail Cap(c_a), veh/h	2796	0	0	1472	1317	2062
HCM Platoon Ratio	1.00	1.00	1.00	1.00	1.00	1.00
Upstream Filter(I)	1.00	0.00	0.00	1.00	1.00	1.00
Uniform Delay (d), s/veh	9.3	0.0	0.0	11.6	9.8	8.7
Incr Delay (d2), s/veh	0.1	0.0	0.0	1.8	1.5	0.4
Initial Q Delay(d3),s/veh	0.0	0.0	0.0	0.0	0.0	0.0
%ile BackOfQ(50%),veh/ln	0.8	0.0	0.0	3.3	3.5	1.7
Unsig. Movement Delay, s/veh						
LnGrp Delay(d),s/veh	9.4	0.0	0.0	13.4	11.3	9.1
LnGrp LOS	A	A	A	B	B	A
Approach Vol, veh/h	370			530	1256	
Approach Delay, s/veh	9.4			13.4	10.1	
Approach LOS	A			B	B	
Timer - Assigned Phs		2			6	8
Phs Duration (G+Y+Rc), s		19.6			19.6	22.4
Change Period (Y+Rc), s		4.0			4.0	4.0
Max Green Setting (Gmax), s		33.0			33.0	31.0
Max Q Clear Time (g_c+I1), s		5.1			12.4	13.5
Green Ext Time (p_c), s		2.3			3.1	4.9
<b>Intersection Summary</b>						
HCM 6th Ctrl Delay			10.8			
HCM 6th LOS			B			

# HCM Signalized Intersection Capacity Analysis

## 4: Shiloh Road & US 101 SB Off-Ramp

Existing Conditions  
Timing Plan: P.M. Peak



Movement	EBL	EBT	WBT	WBR	SBL	SBR
Lane Configurations		↑	↑		↘	↘
Traffic Volume (vph)	0	423	615	0	121	110
Future Volume (vph)	0	423	615	0	121	110
Ideal Flow (vphpl)	1900	1900	1900	1900	1900	1900
Total Lost time (s)		4.0	4.0		4.0	4.0
Lane Util. Factor		1.00	1.00		1.00	1.00
Frbp, ped/bikes		1.00	1.00		1.00	0.98
Flpb, ped/bikes		1.00	1.00		1.00	1.00
Frt		1.00	1.00		1.00	0.85
Flt Protected		1.00	1.00		0.95	1.00
Satd. Flow (prot)		1863	1863		1770	1547
Flt Permitted		1.00	1.00		0.95	1.00
Satd. Flow (perm)		1863	1863		1770	1547
Peak-hour factor, PHF	0.89	0.89	0.96	0.96	0.93	0.93
Adj. Flow (vph)	0	475	641	0	130	118
RTOR Reduction (vph)	0	0	0	0	0	96
Lane Group Flow (vph)	0	475	641	0	130	22
Confl. Peds. (#/hr)						1
Turn Type		NA	NA		Perm	Perm
Protected Phases		2	6			
Permitted Phases					4	4
Actuated Green, G (s)		19.7	19.7		6.2	6.2
Effective Green, g (s)		19.7	19.7		6.2	6.2
Actuated g/C Ratio		0.58	0.58		0.18	0.18
Clearance Time (s)		4.0	4.0		4.0	4.0
Vehicle Extension (s)		3.0	3.0		3.0	3.0
Lane Grp Cap (vph)		1082	1082		323	282
v/s Ratio Prot		0.26	c0.34			
v/s Ratio Perm					c0.07	0.01
v/c Ratio		0.44	0.59		0.40	0.08
Uniform Delay, d1		4.0	4.5		12.2	11.5
Progression Factor		1.00	1.00		1.00	1.00
Incremental Delay, d2		0.3	0.9		0.8	0.1
Delay (s)		4.3	5.4		13.0	11.6
Level of Service		A	A		B	B
Approach Delay (s)		4.3	5.4		12.4	
Approach LOS		A	A		B	
<b>Intersection Summary</b>						
HCM 2000 Control Delay			6.3		HCM 2000 Level of Service	A
HCM 2000 Volume to Capacity ratio			0.55			
Actuated Cycle Length (s)			33.9		Sum of lost time (s)	8.0
Intersection Capacity Utilization			58.1%		ICU Level of Service	B
Analysis Period (min)			15			
c Critical Lane Group						

Intersection						
Int Delay, s/veh	2.5					
Movement	EBT	EBR	WBL	WBT	NBL	NBR
Lane Configurations	↑↑		↘	↑	↘	↘
Traffic Vol, veh/h	851	28	79	651	15	149
Future Vol, veh/h	851	28	79	651	15	149
Conflicting Peds, #/hr	0	0	0	0	0	0
Sign Control	Free	Free	Free	Free	Stop	Stop
RT Channelized	-	None	-	None	-	None
Storage Length	-	-	68	-	0	0
Veh in Median Storage, #	0	-	-	0	0	-
Grade, %	0	-	-	0	0	-
Peak Hour Factor	89	89	92	92	89	89
Heavy Vehicles, %	2	2	2	2	2	2
Mvmt Flow	956	31	86	708	17	167

Major/Minor	Major1	Major2	Minor1		
Conflicting Flow All	0	0	987	0	1852 494
Stage 1	-	-	-	-	972 -
Stage 2	-	-	-	-	880 -
Critical Hdwy	-	-	4.13	-	6.63 6.93
Critical Hdwy Stg 1	-	-	-	-	5.83 -
Critical Hdwy Stg 2	-	-	-	-	5.43 -
Follow-up Hdwy	-	-	2.219	-	3.519 3.319
Pot Cap-1 Maneuver	-	-	698	-	73 522
Stage 1	-	-	-	-	328 -
Stage 2	-	-	-	-	404 -
Platoon blocked, %	-	-	-	-	-
Mov Cap-1 Maneuver	-	-	698	-	64 522
Mov Cap-2 Maneuver	-	-	-	-	64 -
Stage 1	-	-	-	-	328 -
Stage 2	-	-	-	-	354 -



















Approach	EB	WB	NB
HCM Control Delay, s	0	1.2	21.1
HCM LOS			C

Minor Lane/Major Mvmt	NBLn1	NBLn2	EBT	EBR	WBL	WBT
Capacity (veh/h)	64	522	-	-	698	-
HCM Lane V/C Ratio	0.263	0.321	-	-	0.123	-
HCM Control Delay (s)	80.3	15.1	-	-	10.9	-
HCM Lane LOS	F	C	-	-	B	-
HCM 95th %tile Q(veh)	0.9	1.4	-	-	0.4	-

# HCM Signalized Intersection Capacity Analysis

## 6: Conde Lane & Shiloh Road

Existing Conditions  
Timing Plan: P.M. Peak

													
Movement	EBL	EBT	EBR	WBL	WBT	WBR	NBL	NBT	NBR	SBL	SBT	SBR	
Lane Configurations													
Traffic Volume (vph)	69	470	2	7	456	289	5	3	17	297	0	39	
Future Volume (vph)	69	470	2	7	456	289	5	3	17	297	0	39	
Ideal Flow (vphp)	1900	1900	1900	1900	1900	1900	1900	1900	1900	1900	1900	1900	
Total Lost time (s)	4.0	4.0		4.0	4.0			4.0			4.0	4.0	
Lane Util. Factor	1.00	0.95		1.00	0.95			1.00			1.00	1.00	
Frbp, ped/bikes	1.00	1.00		1.00	0.99			1.00			1.00	1.00	
Flpb, ped/bikes	1.00	1.00		1.00	1.00			1.00			1.00	1.00	
Frt	1.00	1.00		1.00	0.94			0.91			1.00	0.85	
Flt Protected	0.95	1.00		0.95	1.00			0.99			0.95	1.00	
Satd. Flow (prot)	1770	3537		1770	3306			1676			1770	1583	
Flt Permitted	0.95	1.00		0.95	1.00			0.99			0.95	1.00	
Satd. Flow (perm)	1770	3537		1770	3306			1676			1770	1583	
Peak-hour factor, PHF	0.88	0.88	0.88	0.80	0.80	0.80	0.63	0.63	0.63	0.88	0.88	0.88	
Adj. Flow (vph)	78	534	2	9	570	361	8	5	27	338	0	44	
RTOR Reduction (vph)	0	0	0	0	90	0	0	25	0	0	0	0	
Lane Group Flow (vph)	78	536	0	9	841	0	0	15	0	0	338	44	
Confl. Peds. (#/hr)	1					1							
Turn Type	Prot	NA		Prot	NA		Split	NA		Split	NA	custom	
Protected Phases	5	2		1	6		7	7		4	4		
Permitted Phases												6	
Actuated Green, G (s)	6.4	30.2		1.2	25.0			4.9			12.6	25.0	
Effective Green, g (s)	6.4	30.2		1.2	25.0			4.9			12.6	25.0	
Actuated g/C Ratio	0.10	0.47		0.02	0.39			0.08			0.19	0.39	
Clearance Time (s)	4.0	4.0		4.0	4.0			4.0			4.0	4.0	
Vehicle Extension (s)	3.0	3.0		3.0	3.0			3.0			3.0	3.0	
Lane Grp Cap (vph)	174	1645		32	1273			126			343	609	
v/s Ratio Prot	c0.04	0.15		0.01	c0.25			c0.01			c0.19		
v/s Ratio Perm												0.03	
v/c Ratio	0.45	0.33		0.28	0.66			0.12			0.99	0.07	
Uniform Delay, d1	27.6	10.9		31.4	16.5			28.0			26.1	12.6	
Progression Factor	1.00	1.00		1.00	1.00			1.00			1.00	1.00	
Incremental Delay, d2	1.8	0.1		4.8	1.3			0.4			44.3	0.1	
Delay (s)	29.4	11.1		36.2	17.8			28.4			70.4	12.7	
Level of Service	C	B		D	B			C			E	B	
Approach Delay (s)		13.4			17.9			28.4			63.7		
Approach LOS		B			B			C			E		
<b>Intersection Summary</b>													
HCM 2000 Control Delay			25.6									HCM 2000 Level of Service	C
HCM 2000 Volume to Capacity ratio			0.66										
Actuated Cycle Length (s)			64.9									Sum of lost time (s)	16.0
Intersection Capacity Utilization			61.7%									ICU Level of Service	B
Analysis Period (min)			15										
c Critical Lane Group													

HCM 6th TWSC  
7: Entrance 1/Gridley Drive & Shiloh Road

Existing Conditions  
Timing Plan: P.M. Peak

Intersection												
Int Delay, s/veh	1.1											
Movement	EBL	EBT	EBR	WBL	WBT	WBR	NBL	NBT	NBR	SBL	SBT	SBR
Lane Configurations		↕			↕		↕	↕			↕	
Traffic Vol, veh/h	17	103	0	0	125	0	0	0	0	0	0	14
Future Vol, veh/h	17	103	0	0	125	0	0	0	0	0	0	14
Conflicting Peds, #/hr	1	0	0	0	0	0	0	0	0	0	0	0
Sign Control	Free	Free	Free	Free	Free	Free	Stop	Stop	Stop	Stop	Stop	Stop
RT Channelized	-	-	None	-	-	None	-	-	None	-	-	None
Storage Length	-	-	-	-	-	-	0	-	-	-	-	-
Veh in Median Storage, #	-	0	-	-	0	-	-	0	-	-	0	-
Grade, %	-	0	-	-	0	-	-	0	-	-	0	-
Peak Hour Factor	94	94	94	69	69	69	100	100	100	58	58	58
Heavy Vehicles, %	2	2	2	2	2	2	2	2	2	2	2	2
Mvmt Flow	18	110	0	0	181	0	0	0	0	0	0	24

Major/Minor	Major1			Major2			Minor1			Minor2		
Conflicting Flow All	182	0	0	110	0	0	339	328	110	328	328	182
Stage 1	-	-	-	-	-	-	146	146	-	182	182	-
Stage 2	-	-	-	-	-	-	193	182	-	146	146	-
Critical Hdwy	4.12	-	-	4.12	-	-	7.12	6.52	6.22	7.12	6.52	6.22
Critical Hdwy Stg 1	-	-	-	-	-	-	6.12	5.52	-	6.12	5.52	-
Critical Hdwy Stg 2	-	-	-	-	-	-	6.12	5.52	-	6.12	5.52	-
Follow-up Hdwy	2.218	-	-	2.218	-	-	3.518	4.018	3.318	3.518	4.018	3.318
Pot Cap-1 Maneuver	1393	-	-	1480	-	-	615	591	943	625	591	861
Stage 1	-	-	-	-	-	-	857	776	-	820	749	-
Stage 2	-	-	-	-	-	-	809	749	-	857	776	-
Platoon blocked, %		-	-		-	-						
Mov Cap-1 Maneuver	1392	-	-	1480	-	-	592	582	943	618	582	860
Mov Cap-2 Maneuver	-	-	-	-	-	-	592	582	-	618	582	-
Stage 1	-	-	-	-	-	-	845	765	-	808	748	-
Stage 2	-	-	-	-	-	-	786	748	-	845	765	-

Approach	EB	WB	NB	SB
HCM Control Delay, s	1.1	0	0	9.3
HCM LOS			A	A

Minor Lane/Major Mvmt	NBLn1	NBLn2	EBL	EBT	EBR	WBL	WBT	WBR	SBLn1
Capacity (veh/h)	-	-	1392	-	-	1480	-	-	860
HCM Lane V/C Ratio	-	-	0.013	-	-	-	-	-	0.028
HCM Control Delay (s)	0	0	7.6	0	-	0	-	-	9.3
HCM Lane LOS	A	A	A	A	-	A	-	-	A
HCM 95th %tile Q(veh)	-	-	0	-	-	0	-	-	0.1

HCM 6th TWSC  
8: Old Redwood Hwy & Entrance 1

Existing Conditions  
Timing Plan: P.M. Peak

Intersection												
Int Delay, s/veh	0.2											
Movement	EBL	EBT	EBR	WBL	WBT	WBR	NBL	NBT	NBR	SBL	SBT	SBR
Lane Configurations		↕		↕	↕			↕		↕	↕	
Traffic Vol, veh/h	3	0	0	0	0	0	0	505	0	0	427	0
Future Vol, veh/h	3	0	0	0	0	0	0	505	0	0	427	0
Conflicting Peds, #/hr	0	0	0	0	0	0	0	0	0	0	0	0
Sign Control	Stop	Stop	Stop	Stop	Stop	Stop	Free	Free	Free	Free	Free	Free
RT Channelized	-	-	None	-	-	None	-	-	None	-	-	None
Storage Length	-	-	-	0	-	-	-	-	-	50	-	-
Veh in Median Storage, #	-	0	-	-	0	-	-	0	-	-	0	-
Grade, %	-	0	-	-	0	-	-	0	-	-	0	-
Peak Hour Factor	38	38	38	100	100	100	91	91	91	94	94	94
Heavy Vehicles, %	2	2	2	2	2	2	2	2	2	2	2	2
Mvmt Flow	8	0	0	0	0	0	0	555	0	0	454	0

Major/Minor	Minor2		Minor1		Major1		Major2					
Conflicting Flow All	1009	1009	454	1009	1009	555	454	0	0	555	0	0
Stage 1	454	454	-	555	555	-	-	-	-	-	-	-
Stage 2	555	555	-	454	454	-	-	-	-	-	-	-
Critical Hdwy	7.12	6.52	6.22	7.12	6.52	6.22	4.12	-	-	4.12	-	-
Critical Hdwy Stg 1	6.12	5.52	-	6.12	5.52	-	-	-	-	-	-	-
Critical Hdwy Stg 2	6.12	5.52	-	6.12	5.52	-	-	-	-	-	-	-
Follow-up Hdwy	3.518	4.018	3.318	3.518	4.018	3.318	2.218	-	-	2.218	-	-
Pot Cap-1 Maneuver	219	240	606	219	240	531	1107	-	-	1015	-	-
Stage 1	586	569	-	516	513	-	-	-	-	-	-	-
Stage 2	516	513	-	586	569	-	-	-	-	-	-	-
Platoon blocked, %								-	-	-	-	-
Mov Cap-1 Maneuver	219	240	606	219	240	531	1107	-	-	1015	-	-
Mov Cap-2 Maneuver	219	240	-	219	240	-	-	-	-	-	-	-
Stage 1	586	569	-	516	513	-	-	-	-	-	-	-
Stage 2	516	513	-	586	569	-	-	-	-	-	-	-

Approach	EB	WB	NB	SB
HCM Control Delay, s	22.1	0	0	0
HCM LOS	C	A		

Minor Lane/Major Mvmt	NBL	NBT	NBR	EBLn1	WBLn1	WBLn2	SBL	SBT	SBR
Capacity (veh/h)	1107	-	-	219	-	-	1015	-	-
HCM Lane V/C Ratio	-	-	-	0.036	-	-	-	-	-
HCM Control Delay (s)	0	-	-	22.1	0	0	0	-	-
HCM Lane LOS	A	-	-	C	A	A	A	-	-
HCM 95th %tile Q(veh)	0	-	-	0.1	-	-	0	-	-

HCM 6th TWSC  
9: Entrance 2 & Shiloh Road

Existing Conditions  
Timing Plan: P.M. Peak

Intersection						
Int Delay, s/veh	0					
Movement	EBT	EBR	WBL	WBT	NBL	NBR
Lane Configurations						
Traffic Vol, veh/h	81	0	0	111	0	0
Future Vol, veh/h	81	0	0	111	0	0
Conflicting Peds, #/hr	0	0	0	0	0	0
Sign Control	Free	Free	Free	Free	Stop	Stop
RT Channelized	-	None	-	None	-	None
Storage Length	-	-	-	-	0	0
Veh in Median Storage, #	0	-	-	0	0	-
Grade, %	0	-	-	0	0	-
Peak Hour Factor	92	92	68	68	100	100
Heavy Vehicles, %	2	2	2	2	2	2
Mvmt Flow	88	0	0	163	0	0

Major/Minor	Major1	Major2	Minor1		
Conflicting Flow All	0	0	88	0	251 88
Stage 1	-	-	-	-	88 -
Stage 2	-	-	-	-	163 -
Critical Hdwy	-	-	4.12	-	6.42 6.22
Critical Hdwy Stg 1	-	-	-	-	5.42 -
Critical Hdwy Stg 2	-	-	-	-	5.42 -
Follow-up Hdwy	-	-	2.218	-	3.518 3.318
Pot Cap-1 Maneuver	-	-	1508	-	738 970
Stage 1	-	-	-	-	935 -
Stage 2	-	-	-	-	866 -
Platoon blocked, %	-	-	-	-	-
Mov Cap-1 Maneuver	-	-	1508	-	738 970
Mov Cap-2 Maneuver	-	-	-	-	738 -
Stage 1	-	-	-	-	935 -
Stage 2	-	-	-	-	866 -























Approach	EB	WB	NB
HCM Control Delay, s	0	0	0
HCM LOS			A

Minor Lane/Major Mvmt	NBLn1	NBLn2	EBT	EBR	WBL	WBT
Capacity (veh/h)	-	-	-	-	1508	-
HCM Lane V/C Ratio	-	-	-	-	-	-
HCM Control Delay (s)	0	0	-	-	0	-
HCM Lane LOS	A	A	-	-	A	-
HCM 95th %tile Q(veh)	-	-	-	-	0	-



HCM 6th Signalized Intersection Summary  
 10: US 101 NB Off Ramp/Lakewood Drive & Old Redwood Highway

Existing Conditions  
 Timing Plan: P.M. Peak

												
Movement	EBL	EBT	EBR	WBL	WBT	WBR	NBL	NBT	NBR	SBL	SBT	SBR
Lane Configurations	 				 			 		 		
Traffic Volume (veh/h)	261	350	0	0	497	192	500	412	251	249	0	577
Future Volume (veh/h)	261	350	0	0	497	192	500	412	251	249	0	577
Initial Q (Qb), veh	0	0	0	0	0	0	0	0	0	0	0	0
Ped-Bike Adj(A_pbT)	1.00		1.00	1.00		0.98	1.00		0.99	1.00		1.00
Parking Bus, Adj	1.00	1.00	1.00	1.00	1.00	1.00	1.00	1.00	1.00	1.00	1.00	1.00
Work Zone On Approach		No			No			No			No	
Adj Sat Flow, veh/h/ln	1870	1870	0	0	1870	1870	1870	1870	1870	1870	0	1870
Adj Flow Rate, veh/h	300	402	0	0	546	211	421	618	273	259	0	0
Peak Hour Factor	0.87	0.87	0.87	0.91	0.91	0.91	0.92	0.92	0.92	0.96	0.96	0.96
Percent Heavy Veh, %	2	2	0	0	2	2	2	2	2	2	0	2
Cap, veh/h	388	1010	0	0	933	359	584	805	355	0	0	0
Arrive On Green	0.11	0.54	0.00	0.00	0.37	0.37	0.33	0.33	0.33	0.00	0.00	0.00
Sat Flow, veh/h	3456	1870	0	0	2586	960	1781	2453	1083		0	
Grp Volume(v), veh/h	300	402	0	0	389	368	421	471	420		0.0	
Grp Sat Flow(s),veh/h/ln	1728	1870	0	0	1777	1675	1781	1870	1666			
Q Serve(g_s), s	6.3	9.4	0.0	0.0	13.0	13.1	15.5	16.8	16.9			
Cycle Q Clear(g_c), s	6.3	9.4	0.0	0.0	13.0	13.1	15.5	16.8	16.9			
Prop In Lane	1.00		0.00	0.00		0.57	1.00		0.65			
Lane Grp Cap(c), veh/h	388	1010	0	0	665	627	584	614	547			
V/C Ratio(X)	0.77	0.40	0.00	0.00	0.58	0.59	0.72	0.77	0.77			
Avail Cap(c_a), veh/h	418	1010	0	0	665	627	694	729	649			
HCM Platoon Ratio	1.00	1.00	1.00	1.00	1.00	1.00	1.00	1.00	1.00			
Upstream Filter(I)	1.00	1.00	0.00	0.00	1.00	1.00	1.00	1.00	1.00			
Uniform Delay (d), s/veh	32.1	10.0	0.0	0.0	18.6	18.7	22.0	22.5	22.5			
Incr Delay (d2), s/veh	8.2	1.2	0.0	0.0	3.7	4.0	3.0	4.2	4.7			
Initial Q Delay(d3),s/veh	0.0	0.0	0.0	0.0	0.0	0.0	0.0	0.0	0.0			
%ile BackOfQ(50%),veh/ln	2.9	3.6	0.0	0.0	5.6	5.3	6.5	7.6	6.9			
Unsig. Movement Delay, s/veh												
LnGrp Delay(d),s/veh	40.3	11.2	0.0	0.0	22.4	22.7	25.0	26.6	27.1			
LnGrp LOS	D	B	A	A	C	C	C	C	C			
Approach Vol, veh/h		702			757			1312				
Approach Delay, s/veh		23.6			22.5			26.2				
Approach LOS		C			C			C				
Timer - Assigned Phs		2			5	6		8				
Phs Duration (G+Y+Rc), s		45.3			12.3	33.0		29.1				
Change Period (Y+Rc), s		5.1			4.0	5.1		4.7				
Max Green Setting (Gmax), s		40.2			9.0	27.2		29.0				
Max Q Clear Time (g_c+I1), s		11.4			8.3	15.1		18.9				
Green Ext Time (p_c), s		2.5			0.1	3.7		5.2				

Intersection Summary

HCM 6th Ctrl Delay	24.6
HCM 6th LOS	C

Notes

User approved volume balancing among the lanes for turning movement.  
 Unsignalized Delay for [SBR] is excluded from calculations of the approach delay and intersection delay.

HCM 6th Signalized Intersection Summary  
 12: US 101 SB On Ramp/US 101 SB Off Ramp & Old Redwood Highway

Existing Conditions  
 Timing Plan: P.M. Peak



Movement	EBL	EBT	EBR	WBL	WBT	WBR	NBL	NBT	NBR	SBL	SBT	SBR
Lane Configurations		↑↑	↗	↘	↑↑					↘	↕	
Traffic Volume (veh/h)	0	535	381	381	1024	0	0	0	0	167	0	129
Future Volume (veh/h)	0	535	381	381	1024	0	0	0	0	167	0	129
Initial Q (Qb), veh	0	0	0	0	0	0				0	0	0
Ped-Bike Adj(A_pbT)	1.00		0.98	1.00		1.00				1.00		1.00
Parking Bus, Adj	1.00	1.00	1.00	1.00	1.00	1.00				1.00	1.00	1.00
Work Zone On Approach		No			No						No	
Adj Sat Flow, veh/h/ln	0	1870	1870	1870	1870	0				1870	1870	1870
Adj Flow Rate, veh/h	0	569	405	428	1151	0				178	32	0
Peak Hour Factor	0.94	0.94	0.94	0.89	0.89	0.89				0.83	0.83	0.83
Percent Heavy Veh, %	0	2	2	2	2	0				2	2	2
Cap, veh/h	0	1426	626	461	2551	0				252	264	
Arrive On Green	0.00	0.40	0.40	0.26	0.72	0.00				0.14	0.14	0.00
Sat Flow, veh/h	0	3647	1560	1781	3647	0				1781	1870	0
Grp Volume(v), veh/h	0	569	405	428	1151	0				178	32	0
Grp Sat Flow(s),veh/h/ln	0	1777	1560	1781	1777	0				1781	1870	0
Q Serve(g_s), s	0.0	7.9	14.6	16.3	9.4	0.0				6.6	1.0	0.0
Cycle Q Clear(g_c), s	0.0	7.9	14.6	16.3	9.4	0.0				6.6	1.0	0.0
Prop In Lane	0.00		1.00	1.00		0.00				1.00		0.00
Lane Grp Cap(c), veh/h	0	1426	626	461	2551	0				252	264	
V/C Ratio(X)	0.00	0.40	0.65	0.93	0.45	0.00				0.71	0.12	
Avail Cap(c_a), veh/h	0	1426	626	461	2551	0				264	277	
HCM Platoon Ratio	1.00	1.00	1.00	1.00	1.00	1.00				1.00	1.00	1.00
Upstream Filter(I)	0.00	1.00	1.00	1.00	1.00	0.00				1.00	1.00	0.00
Uniform Delay (d), s/veh	0.0	14.8	16.8	25.1	4.1	0.0				28.5	26.1	0.0
Incr Delay (d2), s/veh	0.0	0.8	5.1	25.1	0.6	0.0				8.0	0.2	0.0
Initial Q Delay(d3),s/veh	0.0	0.0	0.0	0.0	0.0	0.0				0.0	0.0	0.0
%ile BackOfQ(50%),veh/ln	0.0	3.0	5.5	9.5	2.2	0.0				3.3	0.5	0.0
Unsig. Movement Delay, s/veh												
LnGrp Delay(d),s/veh	0.0	15.7	21.9	50.3	4.7	0.0				36.4	26.3	0.0
LnGrp LOS	A	B	C	D	A	A				D	C	
Approach Vol, veh/h		974			1579						210	
Approach Delay, s/veh		18.3			17.0						34.9	
Approach LOS		B			B						C	
Timer - Assigned Phs		2			5	6		8				
Phs Duration (G+Y+Rc), s		55.0			22.0	33.0		14.5				
Change Period (Y+Rc), s		5.1			4.0	5.1		4.7				
Max Green Setting (Gmax), s		49.9			18.0	27.9		10.3				
Max Q Clear Time (g_c+I1), s		11.4			18.3	16.6		8.6				
Green Ext Time (p_c), s		10.5			0.0	4.1		0.1				

Intersection Summary























HCM 6th Ctrl Delay	18.8
HCM 6th LOS	B

Notes

- User approved volume balancing among the lanes for turning movement.
- User approved ignoring U-Turning movement.
- Unsignalized Delay for [SBR] is excluded from calculations of the approach delay and intersection delay.

HCM 6th Signalized Intersection Summary  
 1: Old Redwood Hwy & Shiloh Road

Existing Conditions  
 Timing Plan: Saturday Midday Peak

												
Movement	EBL	EBT	EBR	WBL	WBT	WBR	NBL	NBT	NBR	SBL	SBT	SBR
Lane Configurations												
Traffic Volume (veh/h)	123	71	146	21	71	15	150	229	24	20	184	180
Future Volume (veh/h)	123	71	146	21	71	15	150	229	24	20	184	180
Initial Q (Qb), veh	0	0	0	0	0	0	0	0	0	0	0	0
Ped-Bike Adj(A_pbT)	1.00		0.97	1.00		1.00	1.00		0.98	1.00		0.97
Parking Bus, Adj	1.00	1.00	1.00	1.00	1.00	1.00	1.00	1.00	1.00	1.00	1.00	1.00
Work Zone On Approach		No			No			No			No	
Adj Sat Flow, veh/h/ln	1870	1870	1870	1870	1870	1870	1870	1870	1870	1870	1870	1870
Adj Flow Rate, veh/h	138	80	164	24	83	17	161	246	26	22	202	198
Peak Hour Factor	0.89	0.89	0.89	0.86	0.86	0.86	0.93	0.93	0.93	0.91	0.91	0.91
Percent Heavy Veh, %	2	2	2	2	2	2	2	2	2	2	2	2
Cap, veh/h	328	344	282	37	128	142	243	423	351	202	380	313
Arrive On Green	0.18	0.18	0.18	0.09	0.09	0.09	0.14	0.23	0.23	0.11	0.20	0.20
Sat Flow, veh/h	1781	1870	1533	415	1435	1585	1781	1870	1551	1781	1870	1539
Grp Volume(v), veh/h	138	80	164	107	0	17	161	246	26	22	202	198
Grp Sat Flow(s),veh/h/ln	1781	1870	1533	1850	0	1585	1781	1870	1551	1781	1870	1539
Q Serve(g_s), s	3.0	1.6	4.3	2.5	0.0	0.4	3.8	5.2	0.6	0.5	4.2	5.2
Cycle Q Clear(g_c), s	3.0	1.6	4.3	2.5	0.0	0.4	3.8	5.2	0.6	0.5	4.2	5.2
Prop In Lane	1.00		1.00	0.22		1.00	1.00		1.00	1.00		1.00
Lane Grp Cap(c), veh/h	328	344	282	165	0	142	243	423	351	202	380	313
V/C Ratio(X)	0.42	0.23	0.58	0.65	0.00	0.12	0.66	0.58	0.07	0.11	0.53	0.63
Avail Cap(c_a), veh/h	1236	1298	1064	1599	0	1370	588	1851	1535	243	1489	1225
HCM Platoon Ratio	1.00	1.00	1.00	1.00	1.00	1.00	1.00	1.00	1.00	1.00	1.00	1.00
Upstream Filter(I)	1.00	1.00	1.00	1.00	0.00	1.00	1.00	1.00	1.00	1.00	1.00	1.00
Uniform Delay (d), s/veh	15.9	15.3	16.4	19.3	0.0	18.4	18.0	15.2	13.4	17.5	15.6	16.0
Incr Delay (d2), s/veh	0.9	0.3	1.9	4.2	0.0	0.4	3.1	1.3	0.1	0.2	1.2	2.1
Initial Q Delay(d3),s/veh	0.0	0.0	0.0	0.0	0.0	0.0	0.0	0.0	0.0	0.0	0.0	0.0
%ile BackOfQ(50%),veh/ln	1.1	0.6	1.3	1.1	0.0	0.1	1.4	1.8	0.2	0.2	1.6	1.6
Unsig. Movement Delay, s/veh												
LnGrp Delay(d),s/veh	16.7	15.6	18.3	23.5	0.0	18.8	21.1	16.4	13.5	17.7	16.8	18.1
LnGrp LOS	B	B	B	C	A	B	C	B	B	B	B	B
Approach Vol, veh/h		382			124			433			422	
Approach Delay, s/veh		17.2			22.9			18.0			17.5	
Approach LOS		B			C			B			B	
Timer - Assigned Phs		2	3	4		6	7	8				
Phs Duration (G+Y+Rc), s		12.6	9.5	13.4		8.4	8.5	14.4				
Change Period (Y+Rc), s		4.5	3.5	4.5		4.5	3.5	4.5				
Max Green Setting (Gmax), s		30.5	14.5	35.0		38.0	6.0	43.5				
Max Q Clear Time (g_c+I1), s		6.3	5.8	7.2		4.5	2.5	7.2				
Green Ext Time (p_c), s		1.3	0.2	1.8		0.6	0.0	1.4				
<b>Intersection Summary</b>												
HCM 6th Ctrl Delay			18.0									
HCM 6th LOS			B									

# HCM Signalized Intersection Capacity Analysis

## 2: Shiloh Road & Hembree Ln

Existing Conditions  
Timing Plan: Saturday Midday Peak



Movement	EBL	EBT	WBT	WBR	SBL	SBR
Lane Configurations	↖ ↗	↑	↑ ↗		↖	↗
Traffic Volume (vph)	622	252	202	159	160	580
Future Volume (vph)	622	252	202	159	160	580
Ideal Flow (vphpl)	1900	1900	1900	1900	1900	1900
Total Lost time (s)	4.0	4.0	4.0		4.0	4.0
Lane Util. Factor	0.97	1.00	0.95		1.00	1.00
Frbp, ped/bikes	1.00	1.00	0.99		1.00	1.00
Flpb, ped/bikes	1.00	1.00	1.00		1.00	1.00
Frt	1.00	1.00	0.93		1.00	0.85
Flt Protected	0.95	1.00	1.00		0.95	1.00
Satd. Flow (prot)	3433	1863	3287		1770	1583
Flt Permitted	0.95	1.00	1.00		0.95	1.00
Satd. Flow (perm)	3433	1863	3287		1770	1583
Peak-hour factor, PHF	0.94	0.94	0.96	0.96	0.91	0.91
Adj. Flow (vph)	662	268	210	166	176	637
RTOR Reduction (vph)	0	0	134	0	0	257
Lane Group Flow (vph)	662	268	242	0	176	380
Confl. Peds. (#/hr)	1			1		
Turn Type	Prot	NA	NA		Perm	pm+ov
Protected Phases	5	2	6			5
Permitted Phases					4	4 5
Actuated Green, G (s)	17.2	30.6	9.4		10.7	27.9
Effective Green, g (s)	17.2	30.6	9.4		10.7	27.9
Actuated g/C Ratio	0.35	0.62	0.19		0.22	0.57
Clearance Time (s)	4.0	4.0	4.0		4.0	4.0
Vehicle Extension (s)	3.0	3.0	3.0		3.0	3.0
Lane Grp Cap (vph)	1197	1156	626		384	1024
v/s Ratio Prot	c0.19	0.14	c0.07			0.13
v/s Ratio Perm					c0.10	0.11
v/c Ratio	0.55	0.23	0.39		0.46	0.37
Uniform Delay, d1	12.9	4.1	17.4		16.8	5.9
Progression Factor	1.00	1.00	1.00		1.00	1.00
Incremental Delay, d2	0.6	0.1	0.4		0.9	0.2
Delay (s)	13.5	4.2	17.8		17.6	6.1
Level of Service	B	A	B		B	A
Approach Delay (s)		10.8	17.8		8.6	
Approach LOS		B	B		A	
<b>Intersection Summary</b>						
HCM 2000 Control Delay			11.2		HCM 2000 Level of Service	B
HCM 2000 Volume to Capacity ratio			0.48			
Actuated Cycle Length (s)			49.3		Sum of lost time (s)	12.0
Intersection Capacity Utilization			54.0%		ICU Level of Service	A
Analysis Period (min)			15			
c Critical Lane Group						

HCM 6th Signalized Intersection Summary  
 3: US 101 NB Off-Ramp & Shiloh Road

Existing Conditions  
 Timing Plan: Saturday Midday Peak



Movement	EBT	EBR	WBL	WBT	NBL	NBR
Lane Configurations	↑↑			↑	↘	↗
Traffic Volume (veh/h)	354	0	0	610	352	518
Future Volume (veh/h)	354	0	0	610	352	518
Initial Q (Qb), veh	0	0	0	0	0	0
Ped-Bike Adj(A_pbT)		1.00	1.00		1.00	1.00
Parking Bus, Adj	1.00	1.00	1.00	1.00	1.00	1.00
Work Zone On Approach	No			No	No	
Adj Sat Flow, veh/h/ln	1870	0	0	1870	1870	1870
Adj Flow Rate, veh/h	389	0	0	685	371	545
Peak Hour Factor	0.91	0.91	0.89	0.89	0.95	0.95
Percent Heavy Veh, %	2	0	0	2	2	2
Cap, veh/h	1670	0	0	879	574	900
Arrive On Green	0.47	0.00	0.00	0.47	0.32	0.32
Sat Flow, veh/h	3741	0	0	1870	1781	2790
Grp Volume(v), veh/h	389	0	0	685	371	545
Grp Sat Flow(s),veh/h/ln	1777	0	0	1870	1781	1395
Q Serve(g_s), s	2.5	0.0	0.0	11.8	6.9	6.3
Cycle Q Clear(g_c), s	2.5	0.0	0.0	11.8	6.9	6.3
Prop In Lane		0.00	0.00		1.00	1.00
Lane Grp Cap(c), veh/h	1670	0	0	879	574	900
V/C Ratio(X)	0.23	0.00	0.00	0.78	0.65	0.61
Avail Cap(c_a), veh/h	3042	0	0	1601	1433	2244
HCM Platoon Ratio	1.00	1.00	1.00	1.00	1.00	1.00
Upstream Filter(I)	1.00	0.00	0.00	1.00	1.00	1.00
Uniform Delay (d), s/veh	6.1	0.0	0.0	8.5	11.2	11.0
Incr Delay (d2), s/veh	0.1	0.0	0.0	1.5	1.2	0.7
Initial Q Delay(d3),s/veh	0.0	0.0	0.0	0.0	0.0	0.0
%ile BackOfQ(50%),veh/ln	0.5	0.0	0.0	2.9	2.2	1.6
Unsig. Movement Delay, s/veh						
LnGrp Delay(d),s/veh	6.2	0.0	0.0	10.1	12.4	11.7
LnGrp LOS	A	A	A	B	B	B
Approach Vol, veh/h	389			685	916	
Approach Delay, s/veh	6.2			10.1	12.0	
Approach LOS	A			B	B	
Timer - Assigned Phs		2			6	8
Phs Duration (G+Y+Rc), s		22.1			22.1	16.4
Change Period (Y+Rc), s		4.0			4.0	4.0
Max Green Setting (Gmax), s		33.0			33.0	31.0
Max Q Clear Time (g_c+I1), s		4.5			13.8	8.9
Green Ext Time (p_c), s		2.5			4.3	3.6
<b>Intersection Summary</b>						
HCM 6th Ctrl Delay			10.2			
HCM 6th LOS			B			

# HCM Signalized Intersection Capacity Analysis

## 4: Shiloh Road & US 101 SB Off-Ramp

Existing Conditions  
Timing Plan: Saturday Midday Peak



Movement	EBL	EBT	WBT	WBR	SBL	SBR
Lane Configurations		↑	↑		↘	↘
Traffic Volume (vph)	0	265	515	0	168	151
Future Volume (vph)	0	265	515	0	168	151
Ideal Flow (vphpl)	1900	1900	1900	1900	1900	1900
Total Lost time (s)		4.0	4.0		4.0	4.0
Lane Util. Factor		1.00	1.00		1.00	1.00
Frbp, ped/bikes		1.00	1.00		1.00	1.00
Flpb, ped/bikes		1.00	1.00		1.00	1.00
Frt		1.00	1.00		1.00	0.85
Flt Protected		1.00	1.00		0.95	1.00
Satd. Flow (prot)		1863	1863		1770	1583
Flt Permitted		1.00	1.00		0.95	1.00
Satd. Flow (perm)		1863	1863		1770	1583
Peak-hour factor, PHF	0.96	0.96	0.96	0.96	0.68	0.68
Adj. Flow (vph)	0	276	536	0	247	222
RTOR Reduction (vph)	0	0	0	0	0	154
Lane Group Flow (vph)	0	276	536	0	247	68
Confl. Bikes (#/hr)				2		
Turn Type		NA	NA		Perm	Perm
Protected Phases		2	6			
Permitted Phases					4	4
Actuated Green, G (s)		17.1	17.1		11.0	11.0
Effective Green, g (s)		17.1	17.1		11.0	11.0
Actuated g/C Ratio		0.47	0.47		0.30	0.30
Clearance Time (s)		4.0	4.0		4.0	4.0
Vehicle Extension (s)		3.0	3.0		3.0	3.0
Lane Grp Cap (vph)		882	882		539	482
v/s Ratio Prot		0.15	c0.29			
v/s Ratio Perm					c0.14	0.04
v/c Ratio		0.31	0.61		0.46	0.14
Uniform Delay, d1		5.9	7.0		10.1	9.1
Progression Factor		1.00	1.00		1.00	1.00
Incremental Delay, d2		0.2	1.2		0.6	0.1
Delay (s)		6.1	8.2		10.8	9.2
Level of Service		A	A		B	A
Approach Delay (s)		6.1	8.2		10.0	
Approach LOS		A	A		B	
<b>Intersection Summary</b>						
HCM 2000 Control Delay			8.4		HCM 2000 Level of Service	A
HCM 2000 Volume to Capacity ratio			0.55			
Actuated Cycle Length (s)			36.1		Sum of lost time (s)	8.0
Intersection Capacity Utilization			57.3%		ICU Level of Service	B
Analysis Period (min)			15			
c Critical Lane Group						

Intersection						
Int Delay, s/veh	1.9					
Movement	EBT	EBR	WBL	WBT	NBL	NBR
Lane Configurations	↑↑		↖	↑	↖	↖
Traffic Vol, veh/h	537	20	81	594	16	78
Future Vol, veh/h	537	20	81	594	16	78
Conflicting Peds, #/hr	0	0	0	0	1	0
Sign Control	Free	Free	Free	Free	Stop	Stop
RT Channelized	-	None	-	None	-	None
Storage Length	-	-	68	-	0	0
Veh in Median Storage, #	0	-	-	0	0	-
Grade, %	0	-	-	0	0	-
Peak Hour Factor	92	92	87	87	78	78
Heavy Vehicles, %	2	2	2	2	2	2
Mvmt Flow	584	22	93	683	21	100

Major/Minor	Major1	Major2	Minor1		
Conflicting Flow All	0	0	606	0	1465 303
Stage 1	-	-	-	-	595 -
Stage 2	-	-	-	-	870 -
Critical Hdwy	-	-	4.13	-	6.63 6.93
Critical Hdwy Stg 1	-	-	-	-	5.83 -
Critical Hdwy Stg 2	-	-	-	-	5.43 -
Follow-up Hdwy	-	-	2.219	-	3.519 3.319
Pot Cap-1 Maneuver	-	-	970	-	130 694
Stage 1	-	-	-	-	515 -
Stage 2	-	-	-	-	409 -
Platoon blocked, %	-	-	-	-	-
Mov Cap-1 Maneuver	-	-	970	-	117 694
Mov Cap-2 Maneuver	-	-	-	-	117 -
Stage 1	-	-	-	-	515 -
Stage 2	-	-	-	-	369 -



















Approach	EB	WB	NB
HCM Control Delay, s	0	1.1	16.4
HCM LOS			C

Minor Lane/Major Mvmt	NBLn1	NBLn2	EBT	EBR	WBL	WBT
Capacity (veh/h)	117	694	-	-	970	-
HCM Lane V/C Ratio	0.175	0.144	-	-	0.096	-
HCM Control Delay (s)	42.2	11.1	-	-	9.1	-
HCM Lane LOS	E	B	-	-	A	-
HCM 95th %tile Q(veh)	0.6	0.5	-	-	0.3	-

# HCM Signalized Intersection Capacity Analysis

## 6: Conde Lane & Shiloh Road

Existing Conditions  
Timing Plan: Saturday Midday Peak

													
Movement	EBL	EBT	EBR	WBL	WBT	WBR	NBL	NBT	NBR	SBL	SBT	SBR	
Lane Configurations													
Traffic Volume (vph)	29	353	1	9	393	204	1	0	6	197	0	28	
Future Volume (vph)	29	353	1	9	393	204	1	0	6	197	0	28	
Ideal Flow (vphp)	1900	1900	1900	1900	1900	1900	1900	1900	1900	1900	1900	1900	
Total Lost time (s)	4.0	4.0		4.0	4.0			4.0			4.0	4.0	
Lane Util. Factor	1.00	0.95		1.00	0.95			1.00			1.00	1.00	
Frbp, ped/bikes	1.00	1.00		1.00	0.99			1.00			1.00	1.00	
Flpb, ped/bikes	1.00	1.00		1.00	1.00			1.00			1.00	1.00	
Frt	1.00	1.00		1.00	0.95			0.89			1.00	0.85	
Flt Protected	0.95	1.00		0.95	1.00			0.99			0.95	1.00	
Satd. Flow (prot)	1770	3538		1770	3332			1640			1770	1583	
Flt Permitted	0.95	1.00		0.95	1.00			0.99			0.95	1.00	
Satd. Flow (perm)	1770	3538		1770	3332			1640			1770	1583	
Peak-hour factor, PHF	0.96	0.96	0.96	0.91	0.91	0.91	0.58	0.58	0.58	0.78	0.78	0.78	
Adj. Flow (vph)	30	368	1	10	432	224	2	0	10	253	0	36	
RTOR Reduction (vph)	0	0	0	0	66	0	0	12	0	0	0	0	
Lane Group Flow (vph)	30	369	0	10	590	0	0	0	0	0	253	36	
Confl. Bikes (#/hr)						2							
Turn Type	Prot	NA		Prot	NA		Split	NA		Split	NA	custom	
Protected Phases	5	2		1	6		7	7		4	4		
Permitted Phases												6	
Actuated Green, G (s)	0.9	14.3		0.9	14.3			1.1			12.3	14.3	
Effective Green, g (s)	0.9	14.3		0.9	14.3			1.1			12.3	14.3	
Actuated g/C Ratio	0.02	0.32		0.02	0.32			0.02			0.28	0.32	
Clearance Time (s)	4.0	4.0		4.0	4.0			4.0			4.0	4.0	
Vehicle Extension (s)	3.0	3.0		3.0	3.0			3.0			3.0	3.0	
Lane Grp Cap (vph)	35	1134		35	1068			40			488	507	
v/s Ratio Prot	c0.02	0.10		0.01	c0.18			c0.00			c0.14		
v/s Ratio Perm												0.02	
v/c Ratio	0.86	0.33		0.29	0.55			0.01			0.52	0.07	
Uniform Delay, d1	21.8	11.5		21.5	12.5			21.2			13.6	10.5	
Progression Factor	1.00	1.00		1.00	1.00			1.00			1.00	1.00	
Incremental Delay, d2	94.8	0.2		4.5	0.6			0.1			0.9	0.1	
Delay (s)	116.6	11.7		26.0	13.1			21.3			14.6	10.6	
Level of Service	F	B		C	B			C			B	B	
Approach Delay (s)		19.5			13.3			21.3			14.1		
Approach LOS		B			B			C			B		
<b>Intersection Summary</b>													
HCM 2000 Control Delay			15.4									HCM 2000 Level of Service	B
HCM 2000 Volume to Capacity ratio			0.53										
Actuated Cycle Length (s)			44.6									Sum of lost time (s)	16.0
Intersection Capacity Utilization			48.3%									ICU Level of Service	A
Analysis Period (min)			15										
c	Critical Lane Group												



HCM 6th TWSC  
7: Entrance 1/Gridley Drive & Shiloh Road

Existing Conditions  
Timing Plan: Saturday Midday Peak

Intersection												
Int Delay, s/veh	1.6											
Movement	EBL	EBT	EBR	WBL	WBT	WBR	NBL	NBT	NBR	SBL	SBT	SBR
Lane Configurations		↕			↕		↕	↕			↕	
Traffic Vol, veh/h	20	106	0	0	92	0	0	0	0	0	0	18
Future Vol, veh/h	20	106	0	0	92	0	0	0	0	0	0	18
Conflicting Peds, #/hr	1	0	0	0	0	0	0	0	0	0	0	0
Sign Control	Free	Free	Free	Free	Free	Free	Stop	Stop	Stop	Stop	Stop	Stop
RT Channelized	-	-	None	-	-	None	-	-	None	-	-	None
Storage Length	-	-	-	-	-	-	0	-	-	-	-	-
Veh in Median Storage, #	-	0	-	-	0	-	-	0	-	-	0	-
Grade, %	-	0	-	-	0	-	-	0	-	-	0	-
Peak Hour Factor	93	93	93	88	88	88	100	100	100	56	56	56
Heavy Vehicles, %	2	2	2	2	2	2	2	2	2	2	2	2
Mvmt Flow	22	114	0	0	105	0	0	0	0	0	0	32

Major/Minor	Major1		Major2		Minor1		Minor2					
Conflicting Flow All	106	0	0	114	0	0	279	264	114	264	264	106
Stage 1	-	-	-	-	-	-	158	158	-	106	106	-
Stage 2	-	-	-	-	-	-	121	106	-	158	158	-
Critical Hdwy	4.12	-	-	4.12	-	-	7.12	6.52	6.22	7.12	6.52	6.22
Critical Hdwy Stg 1	-	-	-	-	-	-	6.12	5.52	-	6.12	5.52	-
Critical Hdwy Stg 2	-	-	-	-	-	-	6.12	5.52	-	6.12	5.52	-
Follow-up Hdwy	2.218	-	-	2.218	-	-	3.518	4.018	3.318	3.518	4.018	3.318
Pot Cap-1 Maneuver	1485	-	-	1475	-	-	673	641	939	689	641	948
Stage 1	-	-	-	-	-	-	844	767	-	900	807	-
Stage 2	-	-	-	-	-	-	883	807	-	844	767	-
Platoon blocked, %		-	-		-	-						
Mov Cap-1 Maneuver	1484	-	-	1475	-	-	642	630	939	680	630	947
Mov Cap-2 Maneuver	-	-	-	-	-	-	642	630	-	680	630	-
Stage 1	-	-	-	-	-	-	830	755	-	885	806	-
Stage 2	-	-	-	-	-	-	853	806	-	830	755	-

Approach	EB	WB	NB	SB
HCM Control Delay, s	1.2	0	0	8.9
HCM LOS			A	A

Minor Lane/Major Mvmt	NBLn1	NBLn2	EBL	EBT	EBR	WBL	WBT	WBR	SBLn1
Capacity (veh/h)	-	-	1484	-	-	1475	-	-	947
HCM Lane V/C Ratio			0.014						0.034
HCM Control Delay (s)	0	0	7.5	0	-	0	-	-	8.9
HCM Lane LOS	A	A	A	A	-	A	-	-	A
HCM 95th %tile Q(veh)	-	-	0	-	-	0	-	-	0.1

HCM 6th TWSC  
8: Old Redwood Hwy & Entrance 1

Existing Conditions  
Timing Plan: Saturday Midday Peak

Intersection												
Int Delay, s/veh	0.1											
Movement	EBL	EBT	EBR	WBL	WBT	WBR	NBL	NBT	NBR	SBL	SBT	SBR
Lane Configurations		↕		↕	↕			↕		↕	↕	
Traffic Vol, veh/h	1	0	2	0	0	0	1	403	0	0	342	4
Future Vol, veh/h	1	0	2	0	0	0	1	403	0	0	342	4
Conflicting Peds, #/hr	0	0	0	0	0	0	1	0	4	4	0	1
Sign Control	Stop	Stop	Stop	Stop	Stop	Stop	Free	Free	Free	Free	Free	Free
RT Channelized	-	-	None	-	-	None	-	-	None	-	-	None
Storage Length	-	-	-	0	-	-	-	-	-	50	-	-
Veh in Median Storage, #	-	0	-	-	0	-	-	0	-	-	0	-
Grade, %	-	0	-	-	0	-	-	0	-	-	0	-
Peak Hour Factor	38	38	38	100	100	100	94	94	94	93	93	93
Heavy Vehicles, %	2	2	2	2	2	2	2	2	2	2	2	2
Mvmt Flow	3	0	5	0	0	0	1	429	0	0	368	4

Major/Minor	Minor2		Minor1		Major1		Major2					
Conflicting Flow All	802	806	371	808	808	433	373	0	0	433	0	0
Stage 1	371	371	-	435	435	-	-	-	-	-	-	-
Stage 2	431	435	-	373	373	-	-	-	-	-	-	-
Critical Hdwy	7.12	6.52	6.22	7.12	6.52	6.22	4.12	-	-	4.12	-	-
Critical Hdwy Stg 1	6.12	5.52	-	6.12	5.52	-	-	-	-	-	-	-
Critical Hdwy Stg 2	6.12	5.52	-	6.12	5.52	-	-	-	-	-	-	-
Follow-up Hdwy	3.518	4.018	3.318	3.518	4.018	3.318	2.218	-	-	2.218	-	-
Pot Cap-1 Maneuver	302	316	675	299	315	623	1185	-	-	1127	-	-
Stage 1	649	620	-	600	580	-	-	-	-	-	-	-
Stage 2	603	580	-	648	618	-	-	-	-	-	-	-
Platoon blocked, %								-	-	-	-	-
Mov Cap-1 Maneuver	301	314	674	295	313	621	1184	-	-	1123	-	-
Mov Cap-2 Maneuver	301	314	-	295	313	-	-	-	-	-	-	-
Stage 1	648	619	-	597	577	-	-	-	-	-	-	-
Stage 2	602	577	-	643	617	-	-	-	-	-	-	-

Approach	EB	WB	NB	SB
HCM Control Delay, s	12.7	0	0	0
HCM LOS	B	A		

Minor Lane/Major Mvmt	NBL	NBT	NBR	EBLn1	WBLn1	WBLn2	SBL	SBT	SBR
Capacity (veh/h)	1184	-	-	477	-	-	1123	-	-
HCM Lane V/C Ratio	0.001	-	-	0.017	-	-	-	-	-
HCM Control Delay (s)	8	0	-	12.7	0	0	0	-	-
HCM Lane LOS	A	A	-	B	A	A	A	-	-
HCM 95th %tile Q(veh)	0	-	-	0.1	-	-	0	-	-

HCM 6th TWSC  
9: Entrance 2 & Shiloh Road

Existing Conditions  
Timing Plan: Saturday Midday Peak

Intersection						
Int Delay, s/veh	0					
Movement	EBT	EBR	WBL	WBT	NBL	NBR
Lane Configurations	↔			↔	↔	↔
Traffic Vol, veh/h	92	0	0	86	0	0
Future Vol, veh/h	92	0	0	86	0	0
Conflicting Peds, #/hr	0	1	0	0	0	0
Sign Control	Free	Free	Free	Free	Stop	Stop
RT Channelized	-	None	-	None	-	None
Storage Length	-	-	-	-	0	0
Veh in Median Storage, #	0	-	-	0	0	-
Grade, %	0	-	-	0	0	-
Peak Hour Factor	88	88	80	80	100	100
Heavy Vehicles, %	2	2	2	2	2	2
Mvmt Flow	105	0	0	108	0	0

Major/Minor	Major1	Major2	Minor1		
Conflicting Flow All	0	0	106	0	214
Stage 1	-	-	-	-	106
Stage 2	-	-	-	-	108
Critical Hdwy	-	-	4.12	-	6.42
Critical Hdwy Stg 1	-	-	-	-	5.42
Critical Hdwy Stg 2	-	-	-	-	5.42
Follow-up Hdwy	-	-	2.218	-	3.518
Pot Cap-1 Maneuver	-	-	1485	-	774
Stage 1	-	-	-	-	918
Stage 2	-	-	-	-	916
Platoon blocked, %	-	-	-	-	-
Mov Cap-1 Maneuver	-	-	1484	-	773
Mov Cap-2 Maneuver	-	-	-	-	773
Stage 1	-	-	-	-	917
Stage 2	-	-	-	-	916

Approach	EB	WB	NB
HCM Control Delay, s	0	0	0
HCM LOS			A

Minor Lane/Major Mvmt	NBLn1	NBLn2	EBT	EBR	WBL	WBT
Capacity (veh/h)	-	-	-	-	1484	-
HCM Lane V/C Ratio	-	-	-	-	-	-
HCM Control Delay (s)	0	0	-	-	0	-
HCM Lane LOS	A	A	-	-	A	-
HCM 95th %tile Q(veh)	-	-	-	-	0	-

# HCM 6th Signalized Intersection Summary

Existing Conditions

10: US 101 NB Off Ramp/Lakewood Drive & Old Redwood Highway Timing Plan: Saturday Midday Peak



Movement	EBL	EBT	EBR	WBL	WBT	WBR	NBL	NBT	NBR	SBL	SBT	SBR
Lane Configurations	↔↔	↑			↑↑		↔	↔↔		↔↔		↔
Traffic Volume (veh/h)	252	275	0	0	441	242	281	266	125	214	0	615
Future Volume (veh/h)	252	275	0	0	441	242	281	266	125	214	0	615
Initial Q (Qb), veh	0	0	0	0	0	0	0	0	0	0	0	0
Ped-Bike Adj(A_pbT)	1.00		1.00	1.00		0.99	1.00		1.00	1.00		1.00
Parking Bus, Adj	1.00	1.00	1.00	1.00	1.00	1.00	1.00	1.00	1.00	1.00	1.00	1.00
Work Zone On Approach		No			No			No			No	
Adj Sat Flow, veh/h/ln	1870	1870	0	0	1870	1870	1870	1870	1870	1870	0	1870
Adj Flow Rate, veh/h	265	289	0	0	496	272	229	353	128	243	0	0
Peak Hour Factor	0.95	0.95	0.95	0.89	0.89	0.89	0.98	0.98	0.98	0.88	0.88	0.88
Percent Heavy Veh, %	2	2	0	0	2	2	2	2	2	2	0	2
Cap, veh/h	377	1183	0	0	1015	554	380	562	200	0	0	0
Arrive On Green	0.11	0.63	0.00	0.00	0.46	0.46	0.21	0.21	0.21	0.00	0.00	0.00
Sat Flow, veh/h	3456	1870	0	0	2299	1204	1781	2632	938		0	
Grp Volume(v), veh/h	265	289	0	0	399	369	229	249	232		0.0	
Grp Sat Flow(s),veh/h/ln	1728	1870	0	0	1777	1632	1781	1870	1700			
Q Serve(g_s), s	4.7	4.3	0.0	0.0	9.9	10.0	7.4	7.7	7.9			
Cycle Q Clear(g_c), s	4.7	4.3	0.0	0.0	9.9	10.0	7.4	7.7	7.9			
Prop In Lane	1.00		0.00	0.00		0.74	1.00		0.55			
Lane Grp Cap(c), veh/h	377	1183	0	0	818	752	380	399	363			
V/C Ratio(X)	0.70	0.24	0.00	0.00	0.49	0.49	0.60	0.62	0.64			
Avail Cap(c_a), veh/h	435	1183	0	0	818	752	813	853	775			
HCM Platoon Ratio	1.00	1.00	1.00	1.00	1.00	1.00	1.00	1.00	1.00			
Upstream Filter(I)	1.00	1.00	0.00	0.00	1.00	1.00	1.00	1.00	1.00			
Uniform Delay (d), s/veh	27.3	5.1	0.0	0.0	11.9	12.0	22.6	22.7	22.8			
Incr Delay (d2), s/veh	4.2	0.5	0.0	0.0	2.1	2.3	1.5	1.6	1.9			
Initial Q Delay(d3),s/veh	0.0	0.0	0.0	0.0	0.0	0.0	0.0	0.0	0.0			
%ile BackOfQ(50%),veh/ln	2.0	1.3	0.0	0.0	3.8	3.5	3.1	3.3	3.1			
Unsig. Movement Delay, s/veh												
LnGrp Delay(d),s/veh	31.6	5.6	0.0	0.0	14.0	14.2	24.1	24.3	24.6			
LnGrp LOS	C	A	A	A	B	B	C	C	C			
Approach Vol, veh/h		554			768			710				
Approach Delay, s/veh		18.0			14.1			24.3				
Approach LOS		B			B			C				
Timer - Assigned Phs		2			5	6		8				
Phs Duration (G+Y+Rc), s		45.3			10.9	34.4		18.3				
Change Period (Y+Rc), s		5.1			4.0	5.1		4.7				
Max Green Setting (Gmax), s		40.2			8.0	28.2		29.0				
Max Q Clear Time (g_c+I1), s		6.3			6.7	12.0		9.9				
Green Ext Time (p_c), s		1.7			0.1	4.4		3.5				

## Intersection Summary

HCM 6th Ctrl Delay	18.8
HCM 6th LOS	B

## Notes

User approved volume balancing among the lanes for turning movement.  
 Unsignalized Delay for [SBR] is excluded from calculations of the approach delay and intersection delay.

# HCM 6th Signalized Intersection Summary

Existing Conditions

12: US 101 SB On Ramp/US 101 SB Off Ramp & Old Redwood Highway Timing Plan: Saturday Midday Peak



Movement	EBL	EBT	EBR	WBL	WBT	WBR	NBL	NBT	NBR	SBL	SBT	SBR
Lane Configurations		↑↑	↗	↘	↑↑					↖	↕	
Traffic Volume (veh/h)	0	483	368	428	718	0	0	0	0	133	1	76
Future Volume (veh/h)	0	483	368	428	718	0	0	0	0	133	1	76
Initial Q (Qb), veh	0	0	0	0	0	0				0	0	0
Ped-Bike Adj(A_pbT)	1.00		0.98	1.00		1.00				1.00		1.00
Parking Bus, Adj	1.00	1.00	1.00	1.00	1.00	1.00				1.00	1.00	1.00
Work Zone On Approach		No			No						No	
Adj Sat Flow, veh/h/ln	0	1870	1870	1870	1870	0				1870	1870	1870
Adj Flow Rate, veh/h	0	498	379	446	748	0				146	56	0
Peak Hour Factor	0.97	0.97	0.97	0.96	0.96	0.96				0.72	0.72	0.72
Percent Heavy Veh, %	0	2	2	2	2	0				2	2	2
Cap, veh/h	0	1386	606	484	2556	0				250	263	
Arrive On Green	0.00	0.39	0.39	0.27	0.72	0.00				0.14	0.14	0.00
Sat Flow, veh/h	0	3647	1555	1781	3647	0				1781	1870	0
Grp Volume(v), veh/h	0	498	379	446	748	0				146	56	0
Grp Sat Flow(s),veh/h/ln	0	1777	1555	1781	1777	0				1781	1870	0
Q Serve(g_s), s	0.0	6.9	13.7	17.0	5.2	0.0				5.4	1.9	0.0
Cycle Q Clear(g_c), s	0.0	6.9	13.7	17.0	5.2	0.0				5.4	1.9	0.0
Prop In Lane	0.00		1.00	1.00		0.00				1.00		0.00
Lane Grp Cap(c), veh/h	0	1386	606	484	2556	0				250	263	
V/C Ratio(X)	0.00	0.36	0.63	0.92	0.29	0.00				0.58	0.21	
Avail Cap(c_a), veh/h	0	1386	606	485	2556	0				255	268	
HCM Platoon Ratio	1.00	1.00	1.00	1.00	1.00	1.00				1.00	1.00	1.00
Upstream Filter(I)	0.00	1.00	1.00	1.00	1.00	0.00				1.00	1.00	0.00
Uniform Delay (d), s/veh	0.0	15.1	17.2	24.7	3.5	0.0				28.1	26.6	0.0
Incr Delay (d2), s/veh	0.0	0.7	4.8	23.0	0.3	0.0				3.3	0.4	0.0
Initial Q Delay(d3),s/veh	0.0	0.0	0.0	0.0	0.0	0.0				0.0	0.0	0.0
%ile BackOfQ(50%),veh/ln	0.0	2.7	5.2	9.6	1.2	0.0				2.4	0.8	0.0
Unsig. Movement Delay, s/veh												
LnGrp Delay(d),s/veh	0.0	15.8	22.0	47.7	3.8	0.0				31.4	27.0	0.0
LnGrp LOS	A	B	C	D	A	A				C	C	
Approach Vol, veh/h		877			1194						202	
Approach Delay, s/veh		18.5			20.2						30.1	
Approach LOS		B			C						C	
Timer - Assigned Phs		2			5	6		8				
Phs Duration (G+Y+Rc), s		55.3			23.0	32.3		14.5				
Change Period (Y+Rc), s		5.1			4.0	5.1		4.7				
Max Green Setting (Gmax), s		50.2			19.0	27.2		10.0				
Max Q Clear Time (g_c+I1), s		7.2			19.0	15.7		7.4				
Green Ext Time (p_c), s		5.9			0.0	3.6		0.2				

## Intersection Summary

HCM 6th Ctrl Delay	20.4
HCM 6th LOS	C

## Notes

User approved volume balancing among the lanes for turning movement.

User approved ignoring U-Turning movement.

Unsignalized Delay for [SBR] is excluded from calculations of the approach delay and intersection delay.

Queues  
1: Old Redwood Hwy & Shiloh Road

Existing Conditions  
Timing Plan: A.M. PEAK



Lane Group	EBL	EBT	EBR	WBT	WBR	NBL	NBT	NBR	SBL	SBT	SBR
Lane Group Flow (vph)	133	128	80	83	12	70	130	37	15	268	199
v/c Ratio	0.37	0.34	0.20	0.27	0.03	0.24	0.17	0.05	0.07	0.53	0.39
Control Delay	28.1	27.4	5.1	29.3	0.2	29.7	13.9	1.1	32.6	25.3	11.4
Queue Delay	0.0	0.0	0.0	0.0	0.0	0.0	0.0	0.0	0.0	0.0	0.0
Total Delay	28.1	27.4	5.1	29.3	0.2	29.7	13.9	1.1	32.6	25.3	11.4
Queue Length 50th (ft)	42	41	0	27	0	23	26	0	5	83	20
Queue Length 95th (ft)	98	94	16	79	0	71	85	5	24	175	72
Internal Link Dist (ft)		1709		528			668			695	
Turn Bay Length (ft)	375		140		50	200		98	130		93
Base Capacity (vph)	1031	1086	966	1242	1105	548	1390	1200	227	1191	1036
Starvation Cap Reductn	0	0	0	0	0	0	0	0	0	0	0
Spillback Cap Reductn	0	0	0	0	0	0	0	0	0	0	0
Storage Cap Reductn	0	0	0	0	0	0	0	0	0	0	0
Reduced v/c Ratio	0.13	0.12	0.08	0.07	0.01	0.13	0.09	0.03	0.07	0.23	0.19

Intersection Summary

Queues

2: Shiloh Road & Hembree Ln

Existing Conditions

Timing Plan: A.M. PEAK



Lane Group	EBL	EBT	WBT	SBL	SBR
Lane Group Flow (vph)	347	256	324	76	384
v/c Ratio	0.34	0.18	0.34	0.19	0.40
Control Delay	12.1	3.4	11.6	15.6	2.1
Queue Delay	0.0	0.0	0.0	0.0	0.0
Total Delay	12.1	3.4	11.6	15.6	2.1
Queue Length 50th (ft)	30	19	25	14	0
Queue Length 95th (ft)	63	45	60	45	24
Internal Link Dist (ft)		222	1709	301	
Turn Bay Length (ft)					
Base Capacity (vph)	2596	1863	3293	742	1499
Starvation Cap Reductn	0	0	0	0	0
Spillback Cap Reductn	0	0	0	0	0
Storage Cap Reductn	0	0	0	0	0
Reduced v/c Ratio	0.13	0.14	0.10	0.10	0.26

Intersection Summary

Queues  
3: US 101 NB Off-Ramp & Shiloh Road

Existing Conditions  
Timing Plan: A.M. PEAK



Lane Group	EBT	WBT	NBL	NBR
Lane Group Flow (vph)	240	538	568	428
v/c Ratio	0.17	0.71	0.75	0.30
Control Delay	11.0	19.8	21.5	2.1
Queue Delay	0.0	0.0	0.0	0.0
Total Delay	11.0	19.8	21.5	2.1
Queue Length 50th (ft)	24	136	141	0
Queue Length 95th (ft)	51	273	245	11
Internal Link Dist (ft)	106	291	689	
Turn Bay Length (ft)				265
Base Capacity (vph)	2381	1253	1139	1946
Starvation Cap Reductn	0	0	0	0
Spillback Cap Reductn	0	0	0	0
Storage Cap Reductn	0	0	0	0
Reduced v/c Ratio	0.10	0.43	0.50	0.22
Intersection Summary				



Queues  
4: Shiloh Road & US 101 SB Off-Ramp

Existing Conditions  
Timing Plan: A.M. PEAK

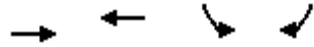

Lane Group	EBT	WBT	SBL	SBR
Lane Group Flow (vph)	243	642	87	150
v/c Ratio	0.20	0.54	0.20	0.29
Control Delay	4.4	7.1	13.9	5.3
Queue Delay	0.0	0.0	0.0	0.0
Total Delay	4.4	7.1	13.9	5.3
Queue Length 50th (ft)	18	62	12	0
Queue Length 95th (ft)	45	145	46	33
Internal Link Dist (ft)	145	226	406	
Turn Bay Length (ft)				275
Base Capacity (vph)	1863	1863	1048	998
Starvation Cap Reductn	0	0	0	0
Spillback Cap Reductn	0	0	0	0
Storage Cap Reductn	0	0	0	0
Reduced v/c Ratio	0.13	0.34	0.08	0.15

Intersection Summary

Queues  
6: Conde Lane & Shiloh Road

Existing Conditions  
Timing Plan: A.M. PEAK

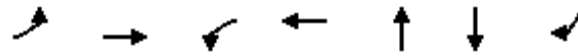

Lane Group	EBL	EBT	WBL	WBT	NBT	SBT	SBR
Lane Group Flow (vph)	26	345	11	653	28	239	41
v/c Ratio	0.07	0.26	0.03	0.54	0.06	0.46	0.08
Control Delay	23.5	11.2	23.7	13.1	0.2	24.8	14.1
Queue Delay	0.0	0.0	0.0	0.0	0.0	0.0	0.0
Total Delay	23.5	11.2	23.7	13.1	0.2	24.8	14.1
Queue Length 50th (ft)	3	18	1	30	0	29	4
Queue Length 95th (ft)	30	84	16	127	0	#195	29
Internal Link Dist (ft)		735		1001	338	442	
Turn Bay Length (ft)	90		127				40
Base Capacity (vph)	424	3027	377	2864	1344	520	1347
Starvation Cap Reductn	0	0	0	0	0	0	0
Spillback Cap Reductn	0	0	0	0	0	0	0
Storage Cap Reductn	0	0	0	0	0	0	0
Reduced v/c Ratio	0.06	0.11	0.03	0.23	0.02	0.46	0.03

Intersection Summary

# 95th percentile volume exceeds capacity, queue may be longer.  
Queue shown is maximum after two cycles.

Queues

10: US 101 NB Off Ramp/Lakewood Drive & Old Redwood Highway

Existing Conditions

Timing Plan: A.M. PEAK



Lane Group	EBL	EBT	WBT	NBL	NBT	SBL	SBR
Lane Group Flow (vph)	179	175	710	194	392	133	600
v/c Ratio	0.48	0.18	0.56	0.59	0.56	0.42	0.76
Control Delay	37.6	11.3	21.1	35.0	27.4	38.9	16.6
Queue Delay	0.0	0.0	0.0	0.0	0.0	0.0	0.0
Total Delay	37.6	11.3	21.1	35.0	27.4	38.9	16.6
Queue Length 50th (ft)	41	40	128	92	82	31	114
Queue Length 95th (ft)	74	83	190	161	125	62	232
Internal Link Dist (ft)		146	537		636		
Turn Bay Length (ft)	155			270		120	
Base Capacity (vph)	403	976	1263	608	1250	313	796
Starvation Cap Reductn	0	0	0	0	0	0	0
Spillback Cap Reductn	0	0	0	0	0	0	0
Storage Cap Reductn	0	0	0	0	0	0	0
Reduced v/c Ratio	0.44	0.18	0.56	0.32	0.31	0.42	0.75

Intersection Summary

Queues

12: US 101 SB On Ramp/US 101 SB Off Ramp & Old Redwood Highway

Existing Conditions

Timing Plan: A.M. PEAK



Lane Group	EBT	EBR	WBL	WBT	SBL	SBT
Lane Group Flow (vph)	324	322	576	566	103	92
v/c Ratio	0.24	0.41	0.92	0.20	0.47	0.34
Control Delay	18.7	4.2	47.4	2.8	40.4	14.3
Queue Delay	0.0	0.0	0.0	0.0	0.0	0.0
Total Delay	18.7	4.2	47.4	2.8	40.4	14.3
Queue Length 50th (ft)	61	0	267	34	51	5
Queue Length 95th (ft)	93	52	#451	46	90	40
Internal Link Dist (ft)	343			451		751
Turn Bay Length (ft)			250		420	
Base Capacity (vph)	1350	793	670	2838	219	269
Starvation Cap Reductn	0	0	0	0	0	0
Spillback Cap Reductn	0	0	0	0	0	0
Storage Cap Reductn	0	0	0	0	0	0
Reduced v/c Ratio	0.24	0.41	0.86	0.20	0.47	0.34

Intersection Summary

# 95th percentile volume exceeds capacity, queue may be longer.  
 Queue shown is maximum after two cycles.

Queues  
1: Old Redwood Hwy & Shiloh Road

Existing Conditions  
Timing Plan: P.M. Peak



Lane Group	EBL	EBT	EBR	WBT	WBR	NBL	NBT	NBR	SBL	SBT	SBR
Lane Group Flow (vph)	248	86	165	127	18	151	362	23	25	251	157
v/c Ratio	0.62	0.20	0.34	0.46	0.06	0.51	0.49	0.04	0.18	0.61	0.37
Control Delay	35.3	27.4	7.0	38.9	0.3	40.0	23.4	0.1	43.4	35.9	13.9
Queue Delay	0.0	0.0	0.0	0.0	0.0	0.0	0.0	0.0	0.0	0.0	0.0
Total Delay	35.3	27.4	7.0	38.9	0.3	40.0	23.4	0.1	43.4	35.9	13.9
Queue Length 50th (ft)	104	33	0	55	0	63	110	0	11	106	19
Queue Length 95th (ft)	217	82	49	133	0	161	289	0	44	223	80
Internal Link Dist (ft)		1709		528			668			695	
Turn Bay Length (ft)	375		140		50	200		98	130		93
Base Capacity (vph)	744	783	761	960	861	354	1117	958	146	899	799
Starvation Cap Reductn	0	0	0	0	0	0	0	0	0	0	0
Spillback Cap Reductn	0	0	0	0	0	0	0	0	0	0	0
Storage Cap Reductn	0	0	0	0	0	0	0	0	0	0	0
Reduced v/c Ratio	0.33	0.11	0.22	0.13	0.02	0.43	0.32	0.02	0.17	0.28	0.20

Intersection Summary

Queues

2: Shiloh Road & Hembree Ln

Existing Conditions

Timing Plan: P.M. Peak



Lane Group	EBL	EBT	WBT	SBL	SBR
Lane Group Flow (vph)	654	354	447	179	517
v/c Ratio	0.58	0.31	0.54	0.47	0.44
Control Delay	16.8	5.3	14.7	24.0	2.1
Queue Delay	0.0	0.0	0.0	0.0	0.0
Total Delay	16.8	5.3	14.7	24.0	2.1
Queue Length 50th (ft)	80	41	38	45	4
Queue Length 95th (ft)	143	77	83	118	35
Internal Link Dist (ft)		222	1709	301	
Turn Bay Length (ft)					
Base Capacity (vph)	1759	1863	2720	471	1371
Starvation Cap Reductn	0	0	0	0	0
Spillback Cap Reductn	0	0	0	0	0
Storage Cap Reductn	0	0	0	0	0
Reduced v/c Ratio	0.37	0.19	0.16	0.38	0.38

Intersection Summary

Queues  
3: US 101 NB Off-Ramp & Shiloh Road

Existing Conditions  
Timing Plan: P.M. Peak

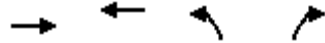

Lane Group	EBT	WBT	NBL	NBR
Lane Group Flow (vph)	370	530	584	672
v/c Ratio	0.26	0.71	0.75	0.42
Control Delay	11.9	20.5	21.4	2.1
Queue Delay	0.0	0.0	0.0	0.0
Total Delay	11.9	20.5	21.4	2.1
Queue Length 50th (ft)	41	142	150	0
Queue Length 95th (ft)	75	268	#352	30
Internal Link Dist (ft)	106	291	689	
Turn Bay Length (ft)				265
Base Capacity (vph)	2333	1228	1097	1983
Starvation Cap Reductn	0	0	0	0
Spillback Cap Reductn	0	0	0	0
Storage Cap Reductn	0	0	0	0
Reduced v/c Ratio	0.16	0.43	0.53	0.34

Intersection Summary

# 95th percentile volume exceeds capacity, queue may be longer.  
Queue shown is maximum after two cycles.

Queues

4: Shiloh Road & US 101 SB Off-Ramp

Existing Conditions

Timing Plan: P.M. Peak

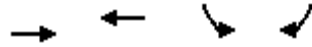

Lane Group	EBT	WBT	SBL	SBR
Lane Group Flow (vph)	475	641	130	118
v/c Ratio	0.40	0.54	0.28	0.24
Control Delay	5.9	7.4	15.2	5.4
Queue Delay	0.0	0.0	0.0	0.0
Total Delay	5.9	7.4	15.2	5.4
Queue Length 50th (ft)	44	67	19	0
Queue Length 95th (ft)	103	161	68	30
Internal Link Dist (ft)	145	226	406	
Turn Bay Length (ft)				275
Base Capacity (vph)	1863	1863	1006	931
Starvation Cap Reductn	0	0	0	0
Spillback Cap Reductn	0	0	0	0
Storage Cap Reductn	0	0	0	0
Reduced v/c Ratio	0.25	0.34	0.13	0.13

Intersection Summary



Queues  
6: Conde Lane & Shiloh Road

Existing Conditions  
Timing Plan: P.M. Peak

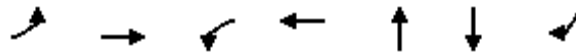

Lane Group	EBL	EBT	WBL	WBT	NBT	SBT	SBR
Lane Group Flow (vph)	78	536	9	931	40	338	44
v/c Ratio	0.28	0.30	0.03	0.70	0.12	0.92	0.07
Control Delay	32.8	10.4	31.6	17.5	17.6	66.7	14.6
Queue Delay	0.0	0.0	0.0	0.0	0.0	0.0	0.0
Total Delay	32.8	10.4	31.6	17.5	17.6	66.7	14.6
Queue Length 50th (ft)	31	62	4	154	5	~184	13
Queue Length 95th (ft)	76	123	16	178	19	#376	31
Internal Link Dist (ft)		735		1001	338	442	
Turn Bay Length (ft)	90		127				40
Base Capacity (vph)	300	2519	267	2359	1021	366	1108
Starvation Cap Reductn	0	0	0	0	0	0	0
Spillback Cap Reductn	0	0	0	0	0	0	0
Storage Cap Reductn	0	0	0	0	0	0	0
Reduced v/c Ratio	0.26	0.21	0.03	0.39	0.04	0.92	0.04

Intersection Summary

~ Volume exceeds capacity, queue is theoretically infinite.  
Queue shown is maximum after two cycles.

# 95th percentile volume exceeds capacity, queue may be longer.  
Queue shown is maximum after two cycles.

Queues

10: US 101 NB Off Ramp/Lakewood Drive & Old Redwood Highway

Existing Conditions

Timing Plan: P.M. Peak



Lane Group	EBL	EBT	WBT	NBL	NBT	SBL	SBR
Lane Group Flow (vph)	300	402	757	424	840	259	601
v/c Ratio	0.86	0.47	0.70	0.85	0.80	0.95	0.67
Control Delay	64.1	19.6	29.0	46.2	31.9	87.1	12.8
Queue Delay	0.0	0.0	0.0	0.0	0.0	0.0	0.0
Total Delay	64.1	19.6	29.0	46.2	31.9	87.1	12.8
Queue Length 50th (ft)	88	156	183	241	212	77	119
Queue Length 95th (ft)	#151	227	249	#413	290	#153	239
Internal Link Dist (ft)		146	537		636		
Turn Bay Length (ft)	155			270		120	
Base Capacity (vph)	349	847	1081	527	1100	272	896
Starvation Cap Reductn	0	0	0	0	0	0	0
Spillback Cap Reductn	0	0	0	0	0	0	0
Storage Cap Reductn	0	0	0	0	0	0	0
Reduced v/c Ratio	0.86	0.47	0.70	0.80	0.76	0.95	0.67

Intersection Summary

# 95th percentile volume exceeds capacity, queue may be longer.  
 Queue shown is maximum after two cycles.

Queues

12: US 101 SB On Ramp/US 101 SB Off Ramp & Old Redwood Highway

Existing Conditions

Timing Plan: P.M. Peak



Lane Group	EBT	EBR	WBL	WBT	SBL	SBT
Lane Group Flow (vph)	569	405	428	1151	181	175
v/c Ratio	0.40	0.47	0.94	0.46	0.74	0.54
Control Delay	16.1	3.7	58.1	5.0	48.7	17.1
Queue Delay	0.0	0.0	0.0	0.0	0.0	0.0
Total Delay	16.1	3.7	58.1	5.0	48.7	17.1
Queue Length 50th (ft)	89	0	180	87	80	22
Queue Length 95th (ft)	128	49	#340	116	#152	67
Internal Link Dist (ft)	343			451		751
Turn Bay Length (ft)			250		420	
Base Capacity (vph)	1411	864	455	2524	247	327
Starvation Cap Reductn	0	0	0	0	0	0
Spillback Cap Reductn	0	0	0	0	0	0
Storage Cap Reductn	0	0	0	0	0	0
Reduced v/c Ratio	0.40	0.47	0.94	0.46	0.73	0.54

Intersection Summary

# 95th percentile volume exceeds capacity, queue may be longer.  
 Queue shown is maximum after two cycles.

Queues  
1: Old Redwood Hwy & Shiloh Road

Existing Conditions  
Timing Plan: Saturday Midday Peak



Lane Group	EBL	EBT	EBR	WBT	WBR	NBL	NBT	NBR	SBL	SBT	SBR
Lane Group Flow (vph)	138	80	164	107	17	161	246	26	22	202	198
v/c Ratio	0.43	0.24	0.39	0.37	0.05	0.44	0.30	0.04	0.12	0.51	0.43
Control Delay	30.5	27.0	8.3	31.1	0.3	29.9	16.9	0.1	34.0	29.2	10.0
Queue Delay	0.0	0.0	0.0	0.0	0.0	0.0	0.0	0.0	0.0	0.0	0.0
Total Delay	30.5	27.0	8.3	31.1	0.3	29.9	16.9	0.1	34.0	29.2	10.0
Queue Length 50th (ft)	49	27	0	38	0	54	55	0	8	71	10
Queue Length 95th (ft)	113	71	47	91	0	136	157	0	34	152	65
Internal Link Dist (ft)		1709		528			668			695	
Turn Bay Length (ft)	375		140		50	200		98	130		93
Base Capacity (vph)	932	981	893	1204	1071	443	1340	1137	183	1126	997
Starvation Cap Reductn	0	0	0	0	0	0	0	0	0	0	0
Spillback Cap Reductn	0	0	0	0	0	0	0	0	0	0	0
Storage Cap Reductn	0	0	0	0	0	0	0	0	0	0	0
Reduced v/c Ratio	0.15	0.08	0.18	0.09	0.02	0.36	0.18	0.02	0.12	0.18	0.20

Intersection Summary

Queues

2: Shiloh Road & Hembree Ln

Existing Conditions

Timing Plan: Saturday Midday Peak



Lane Group	EBL	EBT	WBT	SBL	SBR
Lane Group Flow (vph)	662	268	376	176	637
v/c Ratio	0.56	0.23	0.50	0.46	0.52
Control Delay	15.6	4.9	13.5	23.3	2.3
Queue Delay	0.0	0.0	0.0	0.0	0.0
Total Delay	15.6	4.9	13.5	23.3	2.3
Queue Length 50th (ft)	77	29	28	44	4
Queue Length 95th (ft)	138	58	70	113	34
Internal Link Dist (ft)		222	1709	301	
Turn Bay Length (ft)					
Base Capacity (vph)	1792	1863	2712	480	1406
Starvation Cap Reductn	0	0	0	0	0
Spillback Cap Reductn	0	0	0	0	0
Storage Cap Reductn	0	0	0	0	0
Reduced v/c Ratio	0.37	0.14	0.14	0.37	0.45

Intersection Summary

Queues  
3: US 101 NB Off-Ramp & Shiloh Road

Existing Conditions  
Timing Plan: Saturday Midday Peak

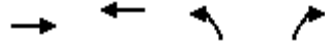

Lane Group	EBT	WBT	NBL	NBR
Lane Group Flow (vph)	389	685	371	545
v/c Ratio	0.23	0.77	0.60	0.41
Control Delay	8.8	19.1	19.0	2.5
Queue Delay	0.0	0.0	0.0	0.0
Total Delay	8.8	19.1	19.0	2.5
Queue Length 50th (ft)	31	148	85	0
Queue Length 95th (ft)	73	351	189	28
Internal Link Dist (ft)	106	291	689	
Turn Bay Length (ft)				265
Base Capacity (vph)	2458	1294	1176	2035
Starvation Cap Reductn	0	0	0	0
Spillback Cap Reductn	0	0	0	0
Storage Cap Reductn	0	0	0	0
Reduced v/c Ratio	0.16	0.53	0.32	0.27
<b>Intersection Summary</b>				

Queues  
4: Shiloh Road & US 101 SB Off-Ramp

Existing Conditions  
Timing Plan: Saturday Midday Peak

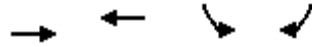

Lane Group	EBT	WBT	SBL	SBR
Lane Group Flow (vph)	276	536	247	222
v/c Ratio	0.32	0.61	0.46	0.35
Control Delay	7.4	11.0	14.7	4.1
Queue Delay	0.0	0.0	0.0	0.0
Total Delay	7.4	11.0	14.7	4.1
Queue Length 50th (ft)	29	66	39	0
Queue Length 95th (ft)	76	166	73	14
Internal Link Dist (ft)	145	226	406	
Turn Bay Length (ft)				275
Base Capacity (vph)	1863	1863	864	886
Starvation Cap Reductn	0	0	0	0
Spillback Cap Reductn	0	0	0	0
Storage Cap Reductn	0	0	0	0
Reduced v/c Ratio	0.15	0.29	0.29	0.25
Intersection Summary				

Queues  
6: Conde Lane & Shiloh Road

Existing Conditions  
Timing Plan: Saturday Midday Peak

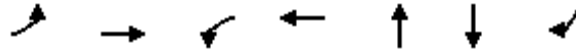

Lane Group	EBL	EBT	WBL	WBT	NBT	SBT	SBR
Lane Group Flow (vph)	30	369	10	656	12	253	36
v/c Ratio	0.07	0.28	0.02	0.51	0.02	0.45	0.06
Control Delay	18.7	10.3	19.1	10.5	0.1	20.5	10.5
Queue Delay	0.0	0.0	0.0	0.0	0.0	0.0	0.0
Total Delay	18.7	10.3	19.1	10.5	0.1	20.5	10.5
Queue Length 50th (ft)	4	19	1	32	0	32	3
Queue Length 95th (ft)	34	90	17	146	0	#182	24
Internal Link Dist (ft)		735		1001	338	442	
Turn Bay Length (ft)	90		127				40
Base Capacity (vph)	463	3266	411	3074	1463	565	1456
Starvation Cap Reductn	0	0	0	0	0	0	0
Spillback Cap Reductn	0	0	0	0	0	0	0
Storage Cap Reductn	0	0	0	0	0	0	0
Reduced v/c Ratio	0.06	0.11	0.02	0.21	0.01	0.45	0.02

Intersection Summary

# 95th percentile volume exceeds capacity, queue may be longer.  
Queue shown is maximum after two cycles.



Queues

Existing Conditions

10: US 101 NB Off Ramp/Lakewood Drive & Old Redwood Highway

Timing Plan: Saturday Midday Peak



Lane Group	EBL	EBT	WBT	NBL	NBT	SBL	SBR
Lane Group Flow (vph)	265	289	768	230	456	243	699
v/c Ratio	0.76	0.30	0.61	0.63	0.59	0.80	0.86
Control Delay	52.0	13.7	20.8	35.3	26.2	57.8	23.5
Queue Delay	0.0	0.0	0.0	0.0	0.0	0.0	0.0
Total Delay	52.0	13.7	20.8	35.3	26.2	57.8	23.5
Queue Length 50th (ft)	67	78	134	113	95	61	173
Queue Length 95th (ft)	#142	159	223	187	141	#134	316
Internal Link Dist (ft)		146	537		636		
Turn Bay Length (ft)	155			270		120	
Base Capacity (vph)	348	949	1267	591	1220	304	812
Starvation Cap Reductn	0	0	0	0	0	0	0
Spillback Cap Reductn	0	0	0	0	0	0	0
Storage Cap Reductn	0	0	0	0	0	0	0
Reduced v/c Ratio	0.76	0.30	0.61	0.39	0.37	0.80	0.86

Intersection Summary

# 95th percentile volume exceeds capacity, queue may be longer.  
 Queue shown is maximum after two cycles.

Queues

Existing Conditions

12: US 101 SB On Ramp/US 101 SB Off Ramp & Old Redwood Highway Timing Plan: Saturday Midday Peak

























Lane Group	EBT	EBR	WBL	WBT	SBL	SBT
Lane Group Flow (vph)	498	379	446	748	152	140
v/c Ratio	0.36	0.45	0.94	0.29	0.63	0.45
Control Delay	16.1	3.8	55.6	3.9	41.9	14.8
Queue Delay	0.0	0.0	0.0	0.0	0.0	0.0
Total Delay	16.1	3.8	55.6	3.9	41.9	14.8
Queue Length 50th (ft)	77	0	186	47	66	13
Queue Length 95th (ft)	114	49	#354	67	96	40
Internal Link Dist (ft)	343			451		751
Turn Bay Length (ft)			250		420	
Base Capacity (vph)	1381	837	480	2537	240	312
Starvation Cap Reductn	0	0	0	0	0	0
Spillback Cap Reductn	0	0	0	0	0	0
Storage Cap Reductn	0	0	0	0	0	0
Reduced v/c Ratio	0.36	0.45	0.93	0.29	0.63	0.45

Intersection Summary

# 95th percentile volume exceeds capacity, queue may be longer.  
 Queue shown is maximum after two cycles.

Lanes, Volumes, Timings  
1: Old Redwood Hwy & Shiloh Road

Existing Conditions  
Timing Plan: A.M. PEAK

												
Lane Group	EBL	EBT	EBR	WBL	WBT	WBR	NBL	NBT	NBR	SBL	SBT	SBR
Lane Configurations												
Traffic Volume (vph)	108	104	65	22	52	11	65	121	34	13	228	169
Future Volume (vph)	108	104	65	22	52	11	65	121	34	13	228	169
Ideal Flow (vphpl)	1900	1900	1900	1900	1900	1900	1900	1900	1900	1900	1900	1900
Storage Length (ft)	375		140	0		50	200		98	130		93
Storage Lanes	1		1	0		1	1		1	1		1
Taper Length (ft)	50			25			60			93		
Lane Util. Factor	1.00	1.00	1.00	1.00	1.00	1.00	1.00	1.00	1.00	1.00	1.00	1.00
Ped Bike Factor												0.98
Frt			0.850			0.850			0.850			0.850
Flt Protected	0.950				0.985		0.950			0.950		
Satd. Flow (prot)	1770	1863	1583	0	1835	1583	1770	1863	1583	1770	1863	1583
Flt Permitted	0.950				0.985		0.950			0.950		
Satd. Flow (perm)	1770	1863	1583	0	1835	1583	1770	1863	1583	1770	1863	1549
Right Turn on Red			Yes			Yes			Yes			Yes
Satd. Flow (RTOR)			105			105			77			126
Link Speed (mph)		40			40			45			40	
Link Distance (ft)		1789			608			748			775	
Travel Time (s)		30.5			10.4			11.3			13.2	
Confl. Bikes (#/hr)												1
Peak Hour Factor	0.81	0.81	0.81	0.89	0.89	0.89	0.93	0.93	0.93	0.85	0.85	0.85
Adj. Flow (vph)	133	128	80	25	58	12	70	130	37	15	268	199
Shared Lane Traffic (%)												
Lane Group Flow (vph)	133	128	80	0	83	12	70	130	37	15	268	199
Enter Blocked Intersection	No	No	No	No	No	No	No	No	No	No	No	No
Lane Alignment	Left	Left	Right	Left	Left	Right	Left	Left	Right	Left	Left	Right
Median Width(ft)		12			12			12			12	
Link Offset(ft)		0			0			0			0	
Crosswalk Width(ft)		16			16			16			16	
Two way Left Turn Lane												
Headway Factor	1.00	1.00	1.00	1.00	1.00	1.00	1.00	1.00	1.00	1.00	1.00	1.00
Turning Speed (mph)	15		9	15		9	15		9	15		9
Number of Detectors	1	2	1	1	2	1	1	2	1	1	2	1
Detector Template	Left	Thru	Right	Left	Thru	Right	Left	Thru	Right	Left	Thru	Right
Leading Detector (ft)	20	100	20	20	100	20	20	100	20	20	100	20
Trailing Detector (ft)	0	0	0	0	0	0	0	0	0	0	0	0
Detector 1 Position(ft)	0	0	0	0	0	0	0	0	0	0	0	0
Detector 1 Size(ft)	20	6	20	20	6	20	20	6	20	20	6	20
Detector 1 Type	Cl+Ex	Cl+Ex	Cl+Ex	Cl+Ex	Cl+Ex	Cl+Ex	Cl+Ex	Cl+Ex	Cl+Ex	Cl+Ex	Cl+Ex	Cl+Ex
Detector 1 Channel												
Detector 1 Extend (s)	0.0	0.0	0.0	0.0	0.0	0.0	0.0	0.0	0.0	0.0	0.0	0.0
Detector 1 Queue (s)	0.0	0.0	0.0	0.0	0.0	0.0	0.0	0.0	0.0	0.0	0.0	0.0
Detector 1 Delay (s)	0.0	0.0	0.0	0.0	0.0	0.0	0.0	0.0	0.0	0.0	0.0	0.0
Detector 2 Position(ft)		94			94			94			94	
Detector 2 Size(ft)		6			6			6			6	
Detector 2 Type		Cl+Ex			Cl+Ex			Cl+Ex			Cl+Ex	
Detector 2 Channel												
Detector 2 Extend (s)		0.0			0.0			0.0			0.0	
Turn Type	Split	NA	Perm	Split	NA	Perm	Prot	NA	Perm	Prot	NA	Perm

Lanes, Volumes, Timings  
1: Old Redwood Hwy & Shiloh Road

Existing Conditions  
Timing Plan: A.M. PEAK



Lane Group	EBL	EBT	EBR	WBL	WBT	WBR	NBL	NBT	NBR	SBL	SBT	SBR
Protected Phases	2	2		6	6		3	8		7	4	
Permitted Phases			2			6			8			4
Detector Phase	2	2	2	6	6	6	3	8	8	7	4	4
Switch Phase												
Minimum Initial (s)	5.0	5.0	5.0	5.0	5.0	5.0	5.0	5.0	5.0	5.0	5.0	5.0
Minimum Split (s)	34.5	34.5	34.5	42.5	42.5	42.5	8.5	46.5	46.5	8.5	39.5	39.5
Total Split (s)	35.0	35.0	35.0	42.5	42.5	42.5	18.0	48.0	48.0	9.5	39.5	39.5
Total Split (%)	25.9%	25.9%	25.9%	31.5%	31.5%	31.5%	13.3%	35.6%	35.6%	7.0%	29.3%	29.3%
Maximum Green (s)	30.5	30.5	30.5	38.0	38.0	38.0	14.5	43.5	43.5	6.0	35.0	35.0
Yellow Time (s)	3.5	3.5	3.5	3.5	3.5	3.5	3.0	3.5	3.5	3.0	3.5	3.5
All-Red Time (s)	1.0	1.0	1.0	1.0	1.0	1.0	0.5	1.0	1.0	0.5	1.0	1.0
Lost Time Adjust (s)	0.0	0.0	0.0		0.0	0.0	0.0	0.0	0.0	0.0	0.0	0.0
Total Lost Time (s)	4.5	4.5	4.5		4.5	4.5	3.5	4.5	4.5	3.5	4.5	4.5
Lead/Lag	Lead	Lead	Lead	Lag	Lag	Lag	Lead	Lag	Lag	Lead	Lag	Lag
Lead-Lag Optimize?	Yes	Yes	Yes	Yes	Yes	Yes	Yes	Yes	Yes	Yes	Yes	Yes
Vehicle Extension (s)	3.0	3.0	3.0	3.0	3.0	3.0	3.0	3.0	3.0	3.0	3.0	3.0
Recall Mode	None	None	None	None	None	None	None	None	None	None	None	None
Walk Time (s)	7.0	7.0	7.0	7.0	7.0	7.0		7.0	7.0		7.0	7.0
Flash Dont Walk (s)	23.0	23.0	23.0	31.0	31.0	31.0		35.0	35.0		28.0	28.0
Pedestrian Calls (#/hr)	0	0	0	0	0	0		0	0		0	0
Act Effct Green (s)	11.6	11.6	11.6		9.7	9.7	9.3	23.1	23.1	7.0	15.5	15.5
Actuated g/C Ratio	0.20	0.20	0.20		0.17	0.17	0.16	0.41	0.41	0.12	0.27	0.27
v/c Ratio	0.37	0.34	0.20		0.27	0.03	0.24	0.17	0.05	0.07	0.53	0.39
Control Delay	28.1	27.4	5.1		29.3	0.2	29.7	13.9	1.1	32.6	25.3	11.4
Queue Delay	0.0	0.0	0.0		0.0	0.0	0.0	0.0	0.0	0.0	0.0	0.0
Total Delay	28.1	27.4	5.1		29.3	0.2	29.7	13.9	1.1	32.6	25.3	11.4
LOS	C	C	A		C	A	C	B	A	C	C	B
Approach Delay		22.4			25.6			16.6			19.8	
Approach LOS		C			C			B			B	
90th %ile Green (s)	17.2	17.2	17.2	12.8	12.8	12.8	12.0	29.8	29.8	6.0	23.8	23.8
90th %ile Term Code	Gap	Gap	Gap	Gap	Gap	Gap	Gap	Hold	Hold	Max	Gap	Gap
70th %ile Green (s)	12.7	12.7	12.7	10.2	10.2	10.2	9.6	31.6	31.6	0.0	18.5	18.5
70th %ile Term Code	Gap	Gap	Gap	Gap	Gap	Gap	Gap	Hold	Hold	Skip	Gap	Gap
50th %ile Green (s)	10.6	10.6	10.6	8.6	8.6	8.6	8.2	26.3	26.3	0.0	14.6	14.6
50th %ile Term Code	Gap	Gap	Gap	Gap	Gap	Gap	Gap	Hold	Hold	Skip	Gap	Gap
30th %ile Green (s)	8.9	8.9	8.9	7.4	7.4	7.4	7.1	22.7	22.7	0.0	12.1	12.1
30th %ile Term Code	Gap	Gap	Gap	Gap	Gap	Gap	Gap	Hold	Hold	Skip	Gap	Gap
10th %ile Green (s)	6.3	6.3	6.3	0.0	0.0	0.0	0.0	7.4	7.4	0.0	7.4	7.4
10th %ile Term Code	Gap	Gap	Gap	Skip	Skip	Skip	Skip	Hold	Hold	Skip	Gap	Gap

Intersection Summary

Area Type:	Other
Cycle Length:	135
Actuated Cycle Length:	57
Natural Cycle:	135
Control Type:	Actuated-Uncoordinated
Maximum v/c Ratio:	0.53
Intersection Signal Delay:	20.4
Intersection LOS:	C
Intersection Capacity Utilization:	39.7%
ICU Level of Service:	A

Lanes, Volumes, Timings  
 1: Old Redwood Hwy & Shiloh Road

Existing Conditions  
 Timing Plan: A.M. PEAK

Analysis Period (min) 15  
 90th %ile Actuated Cycle: 82.8  
 70th %ile Actuated Cycle: 68  
 50th %ile Actuated Cycle: 59  
 30th %ile Actuated Cycle: 52.5  
 10th %ile Actuated Cycle: 22.7

Splits and Phases: 1: Old Redwood Hwy & Shiloh Road

 Ø2	 Ø6	 Ø3	 Ø4
35 s	42.5 s	18 s	39.5 s
		 Ø7	 Ø8
		9.5 s	48 s

Lanes, Volumes, Timings  
2: Shiloh Road & Hembree Ln

Existing Conditions  
Timing Plan: A.M. PEAK



Lane Group	EBL	EBT	WBT	WBR	SBL	SBR
Lane Configurations	↖↖	→	↖↗		↘	↘
Traffic Volume (vph)	305	225	246	68	71	361
Future Volume (vph)	305	225	246	68	71	361
Ideal Flow (vphpl)	1900	1900	1900	1900	1900	1900
Storage Length (ft)	0			130	0	0
Storage Lanes	2			1	1	1
Taper Length (ft)	25				25	
Lane Util. Factor	0.97	1.00	0.95	0.95	1.00	1.00
Frt			0.968			0.850
Flt Protected	0.950				0.950	
Satd. Flow (prot)	3433	1863	3426	0	1770	1583
Flt Permitted	0.950				0.950	
Satd. Flow (perm)	3433	1863	3426	0	1770	1583
Right Turn on Red				Yes		Yes
Satd. Flow (RTOR)			50			384
Link Speed (mph)		40	40		35	
Link Distance (ft)		302	1789		381	
Travel Time (s)		5.1	30.5		7.4	
Peak Hour Factor	0.88	0.88	0.97	0.97	0.94	0.94
Adj. Flow (vph)	347	256	254	70	76	384
Shared Lane Traffic (%)						
Lane Group Flow (vph)	347	256	324	0	76	384
Enter Blocked Intersection	No	No	No	No	No	No
Lane Alignment	Left	Left	Left	Right	Left	Right
Median Width(ft)		24	24		12	
Link Offset(ft)		0	0		0	
Crosswalk Width(ft)		16	16		16	
Two way Left Turn Lane						
Headway Factor	1.00	1.00	1.00	1.00	1.00	1.00
Turning Speed (mph)	15			9	15	9
Number of Detectors	1	2	2		1	1
Detector Template	Left	Thru	Thru		Left	Right
Leading Detector (ft)	20	100	100		20	20
Trailing Detector (ft)	0	0	0		0	0
Detector 1 Position(ft)	0	0	0		0	0
Detector 1 Size(ft)	20	6	6		20	20
Detector 1 Type	Cl+Ex	Cl+Ex	Cl+Ex		Cl+Ex	Cl+Ex
Detector 1 Channel						
Detector 1 Extend (s)	0.0	0.0	0.0		0.0	0.0
Detector 1 Queue (s)	0.0	0.0	0.0		0.0	0.0
Detector 1 Delay (s)	0.0	0.0	0.0		0.0	0.0
Detector 2 Position(ft)		94	94			
Detector 2 Size(ft)		6	6			
Detector 2 Type		Cl+Ex	Cl+Ex			
Detector 2 Channel						
Detector 2 Extend (s)		0.0	0.0			
Turn Type	Prot	NA	NA		Perm	pm+ov
Protected Phases	5	2	6			5
Permitted Phases					4	4 5

Lanes, Volumes, Timings  
2: Shiloh Road & Hembree Ln

Existing Conditions  
Timing Plan: A.M. PEAK



Lane Group	EBL	EBT	WBT	WBR	SBL	SBR
Detector Phase	5	2	6		4	5
Switch Phase						
Minimum Initial (s)	3.0	5.0	5.0		5.0	3.0
Minimum Split (s)	7.0	9.0	43.0		9.0	7.0
Total Split (s)	29.0	73.0	44.0		17.0	29.0
Total Split (%)	32.2%	81.1%	48.9%		18.9%	32.2%
Maximum Green (s)	25.0	69.0	40.0		13.0	25.0
Yellow Time (s)	3.0	3.0	3.0		3.0	3.0
All-Red Time (s)	1.0	1.0	1.0		1.0	1.0
Lost Time Adjust (s)	0.0	0.0	0.0		0.0	0.0
Total Lost Time (s)	4.0	4.0	4.0		4.0	4.0
Lead/Lag	Lead		Lag			Lead
Lead-Lag Optimize?	Yes		Yes			Yes
Vehicle Extension (s)	3.0	3.0	3.0		3.0	3.0
Recall Mode	None	None	None		None	None
Walk Time (s)			7.0			
Flash Dont Walk (s)			32.0			
Pedestrian Calls (#/hr)			0			
Act Effct Green (s)	10.3	26.5	9.2		7.7	16.3
Actuated g/C Ratio	0.30	0.77	0.27		0.22	0.47
v/c Ratio	0.34	0.18	0.34		0.19	0.40
Control Delay	12.1	3.4	11.6		15.6	2.1
Queue Delay	0.0	0.0	0.0		0.0	0.0
Total Delay	12.1	3.4	11.6		15.6	2.1
LOS	B	A	B		B	A
Approach Delay		8.4	11.6		4.3	
Approach LOS		A	B		A	
90th %ile Green (s)	14.3	30.3	12.0		9.6	14.3
90th %ile Term Code	Gap	Hold	Gap		Gap	Gap
70th %ile Green (s)	11.3	25.2	9.9		8.1	11.3
70th %ile Term Code	Gap	Hold	Gap		Gap	Gap
50th %ile Green (s)	10.2	23.0	8.8		7.2	10.2
50th %ile Term Code	Gap	Hold	Gap		Gap	Gap
30th %ile Green (s)	8.3	20.0	7.7		0.0	8.3
30th %ile Term Code	Gap	Hold	Gap		Skip	Gap
10th %ile Green (s)	6.5	16.7	6.2		0.0	6.5
10th %ile Term Code	Gap	Hold	Gap		Skip	Gap

Intersection Summary

Area Type:	Other
Cycle Length:	90
Actuated Cycle Length:	34.4
Natural Cycle:	60
Control Type:	Actuated-Uncoordinated
Maximum v/c Ratio:	0.40
Intersection Signal Delay:	7.8
Intersection LOS:	A
Intersection Capacity Utilization:	38.0%
ICU Level of Service:	A
Analysis Period (min):	15
90th %ile Actuated Cycle:	47.9

Lanes, Volumes, Timings  
 2: Shiloh Road & Hembree Ln

Existing Conditions  
 Timing Plan: A.M. PEAK

70th %ile Actuated Cycle: 41.3  
 50th %ile Actuated Cycle: 38.2  
 30th %ile Actuated Cycle: 24  
 10th %ile Actuated Cycle: 20.7

Splits and Phases: 2: Shiloh Road & Hembree Ln





Lanes, Volumes, Timings  
3: US 101 NB Off-Ramp & Shiloh Road

Existing Conditions  
Timing Plan: A.M. PEAK



Lane Group	EBT	EBR	WBL	WBT	NBL	NBR
Lane Configurations	↑↑			↑	↘	↗↗
Traffic Volume (vph)	218	0	0	484	432	325
Future Volume (vph)	218	0	0	484	432	325
Ideal Flow (vphpl)	1900	1900	1900	1900	1900	1900
Storage Length (ft)		0	0		0	265
Storage Lanes		0	0		1	2
Taper Length (ft)			25		25	
Lane Util. Factor	0.95	1.00	1.00	1.00	1.00	0.88
Frt						0.850
Flt Protected					0.950	
Satd. Flow (prot)	3539	0	0	1863	1770	2787
Flt Permitted					0.950	
Satd. Flow (perm)	3539	0	0	1863	1770	2787
Right Turn on Red		Yes				Yes
Satd. Flow (RTOR)						428
Link Speed (mph)	40			40	30	
Link Distance (ft)	186			371	769	
Travel Time (s)	3.2			6.3	17.5	
Peak Hour Factor	0.91	0.91	0.90	0.90	0.76	0.76
Adj. Flow (vph)	240	0	0	538	568	428
Shared Lane Traffic (%)						
Lane Group Flow (vph)	240	0	0	538	568	428
Enter Blocked Intersection	No	No	No	No	No	No
Lane Alignment	Left	Right	Left	Left	Left	Right
Median Width(ft)	0			0	12	
Link Offset(ft)	0			0	0	
Crosswalk Width(ft)	16			16	16	
Two way Left Turn Lane						
Headway Factor	1.00	1.00	1.00	1.00	1.00	1.00
Turning Speed (mph)		9	15		15	9
Number of Detectors	2			2	1	1
Detector Template	Thru			Thru	Left	Right
Leading Detector (ft)	100			100	20	20
Trailing Detector (ft)	0			0	0	0
Detector 1 Position(ft)	0			0	0	0
Detector 1 Size(ft)	6			6	20	20
Detector 1 Type	Cl+Ex			Cl+Ex	Cl+Ex	Cl+Ex
Detector 1 Channel						
Detector 1 Extend (s)	0.0			0.0	0.0	0.0
Detector 1 Queue (s)	0.0			0.0	0.0	0.0
Detector 1 Delay (s)	0.0			0.0	0.0	0.0
Detector 2 Position(ft)	94			94		
Detector 2 Size(ft)	6			6		
Detector 2 Type	Cl+Ex			Cl+Ex		
Detector 2 Channel						
Detector 2 Extend (s)	0.0			0.0		
Turn Type	NA			NA	Prot	Perm
Protected Phases	2			6	8	
Permitted Phases						8

Lanes, Volumes, Timings  
3: US 101 NB Off-Ramp & Shiloh Road

Existing Conditions  
Timing Plan: A.M. PEAK



Lane Group	EBT	EBR	WBL	WBT	NBL	NBR
Detector Phase	2			6	8	8
Switch Phase						
Minimum Initial (s)	5.0			5.0	5.0	5.0
Minimum Split (s)	9.0			9.0	9.0	9.0
Total Split (s)	37.0			37.0	35.0	35.0
Total Split (%)	51.4%			51.4%	48.6%	48.6%
Maximum Green (s)	33.0			33.0	31.0	31.0
Yellow Time (s)	3.0			3.0	3.0	3.0
All-Red Time (s)	1.0			1.0	1.0	1.0
Lost Time Adjust (s)	0.0			0.0	0.0	0.0
Total Lost Time (s)	4.0			4.0	4.0	4.0
Lead/Lag						
Lead-Lag Optimize?						
Vehicle Extension (s)	3.0			3.0	3.0	3.0
Recall Mode	None			None	None	None
Act Effect Green (s)	21.5			21.5	22.6	22.6
Actuated g/C Ratio	0.41			0.41	0.43	0.43
v/c Ratio	0.17			0.71	0.75	0.30
Control Delay	11.0			19.8	21.5	2.1
Queue Delay	0.0			0.0	0.0	0.0
Total Delay	11.0			19.8	21.5	2.1
LOS	B			B	C	A
Approach Delay	11.0			19.8	13.1	
Approach LOS	B			B	B	
90th %ile Green (s)	33.0			33.0	31.0	31.0
90th %ile Term Code	Hold			Max	Max	Max
70th %ile Green (s)	27.4			27.4	30.1	30.1
70th %ile Term Code	Hold			Gap	Gap	Gap
50th %ile Green (s)	22.2			22.2	23.8	23.8
50th %ile Term Code	Hold			Gap	Gap	Gap
30th %ile Green (s)	16.1			16.1	17.6	17.6
30th %ile Term Code	Hold			Gap	Gap	Gap
10th %ile Green (s)	11.2			11.2	11.9	11.9
10th %ile Term Code	Hold			Gap	Gap	Gap

Intersection Summary

Area Type:	Other
Cycle Length:	72
Actuated Cycle Length:	52.9
Natural Cycle:	45
Control Type:	Actuated-Uncoordinated
Maximum v/c Ratio:	0.75
Intersection Signal Delay:	14.9
Intersection LOS:	B
Intersection Capacity Utilization:	76.4%
ICU Level of Service:	D
Analysis Period (min):	15
90th %ile Actuated Cycle:	72
70th %ile Actuated Cycle:	65.5
50th %ile Actuated Cycle:	54
30th %ile Actuated Cycle:	41.7

10th %ile Actuated Cycle: 31.1

Splits and Phases: 3: US 101 NB Off-Ramp & Shiloh Road

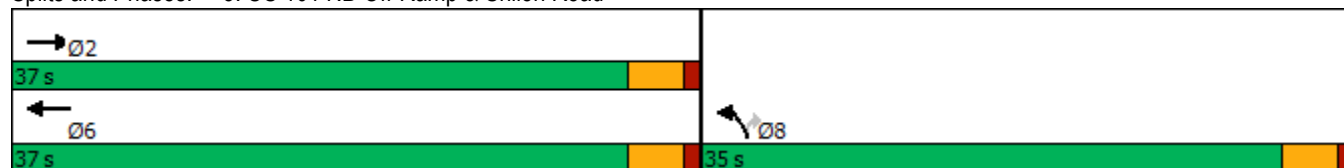

Lanes, Volumes, Timings  
4: Shiloh Road & US 101 SB Off-Ramp

Existing Conditions  
Timing Plan: A.M. PEAK



Lane Group	EBL	EBT	WBT	WBR	SBL	SBR
Lane Configurations		↑	↑		↘	↗
Traffic Volume (vph)	0	226	584	0	80	138
Future Volume (vph)	0	226	584	0	80	138
Ideal Flow (vphpl)	1900	1900	1900	1900	1900	1900
Storage Length (ft)	0			0	0	275
Storage Lanes	0			0	1	1
Taper Length (ft)	25				25	
Lane Util. Factor	1.00	1.00	1.00	1.00	1.00	1.00
Frt						0.850
Flt Protected					0.950	
Satd. Flow (prot)	0	1863	1863	0	1770	1583
Flt Permitted					0.950	
Satd. Flow (perm)	0	1863	1863	0	1770	1583
Right Turn on Red				Yes		Yes
Satd. Flow (RTOR)						150
Link Speed (mph)		40	40		30	
Link Distance (ft)		225	306		486	
Travel Time (s)		3.8	5.2		11.0	
Peak Hour Factor	0.93	0.93	0.91	0.91	0.92	0.92
Adj. Flow (vph)	0	243	642	0	87	150
Shared Lane Traffic (%)						
Lane Group Flow (vph)	0	243	642	0	87	150
Enter Blocked Intersection	No	No	No	No	No	No
Lane Alignment	Left	Left	Left	Right	Left	Right
Median Width(ft)		4	0		12	
Link Offset(ft)		0	0		0	
Crosswalk Width(ft)		16	16		16	
Two way Left Turn Lane						
Headway Factor	1.00	1.00	1.00	1.00	1.00	1.00
Turning Speed (mph)	15			9	15	9
Number of Detectors		2	2		1	1
Detector Template		Thru	Thru		Left	Right
Leading Detector (ft)		100	100		20	20
Trailing Detector (ft)		0	0		0	0
Detector 1 Position(ft)		0	0		0	0
Detector 1 Size(ft)		6	6		20	20
Detector 1 Type		Cl+Ex	Cl+Ex		Cl+Ex	Cl+Ex
Detector 1 Channel						
Detector 1 Extend (s)		0.0	0.0		0.0	0.0
Detector 1 Queue (s)		0.0	0.0		0.0	0.0
Detector 1 Delay (s)		0.0	0.0		0.0	0.0
Detector 2 Position(ft)		94	94			
Detector 2 Size(ft)		6	6			
Detector 2 Type		Cl+Ex	Cl+Ex			
Detector 2 Channel						
Detector 2 Extend (s)		0.0	0.0			
Turn Type		NA	NA		Perm	Perm
Protected Phases		2	6			
Permitted Phases					4	4

Lanes, Volumes, Timings  
4: Shiloh Road & US 101 SB Off-Ramp

Existing Conditions  
Timing Plan: A.M. PEAK



Lane Group	EBL	EBT	WBT	WBR	SBL	SBR
Detector Phase		2	6		4	4
Switch Phase						
Minimum Initial (s)		5.0	5.0		5.0	5.0
Minimum Split (s)		9.0	38.0		9.0	9.0
Total Split (s)		69.0	69.0		21.0	21.0
Total Split (%)		76.7%	76.7%		23.3%	23.3%
Maximum Green (s)		65.0	65.0		17.0	17.0
Yellow Time (s)		3.0	3.0		3.0	3.0
All-Red Time (s)		1.0	1.0		1.0	1.0
Lost Time Adjust (s)		0.0	0.0		0.0	0.0
Total Lost Time (s)		4.0	4.0		4.0	4.0
Lead/Lag						
Lead-Lag Optimize?						
Vehicle Extension (s)		3.0	3.0		3.0	3.0
Recall Mode		None	None		None	None
Walk Time (s)			7.0			
Flash Dont Walk (s)			27.0			
Pedestrian Calls (#/hr)			0			
Act Effct Green (s)		20.1	20.1		7.9	7.9
Actuated g/C Ratio		0.64	0.64		0.25	0.25
v/c Ratio		0.20	0.54		0.20	0.29
Control Delay		4.4	7.1		13.9	5.3
Queue Delay		0.0	0.0		0.0	0.0
Total Delay		4.4	7.1		13.9	5.3
LOS		A	A		B	A
Approach Delay		4.4	7.1		8.5	
Approach LOS		A	A		A	
90th %ile Green (s)		27.1	27.1		9.6	9.6
90th %ile Term Code		Hold	Gap		Gap	Gap
70th %ile Green (s)		21.1	21.1		8.0	8.0
70th %ile Term Code		Hold	Gap		Gap	Gap
50th %ile Green (s)		16.9	16.9		7.1	7.1
50th %ile Term Code		Hold	Gap		Gap	Gap
30th %ile Green (s)		14.3	14.3		6.4	6.4
30th %ile Term Code		Hold	Gap		Gap	Gap
10th %ile Green (s)		10.5	10.5		0.0	0.0
10th %ile Term Code		Hold	Gap		Skip	Skip
<b>Intersection Summary</b>						
Area Type:	Other					
Cycle Length:	90					
Actuated Cycle Length:	31.4					
Natural Cycle:	50					
Control Type:	Actuated-Uncoordinated					
Maximum v/c Ratio:	0.54					
Intersection Signal Delay:	6.8			Intersection LOS: A		
Intersection Capacity Utilization:	54.2%			ICU Level of Service A		
Analysis Period (min):	15					
90th %ile Actuated Cycle:	44.7					

Lanes, Volumes, Timings  
 4: Shiloh Road & US 101 SB Off-Ramp

Existing Conditions  
 Timing Plan: A.M. PEAK

70th %ile Actuated Cycle: 37.1  
 50th %ile Actuated Cycle: 32  
 30th %ile Actuated Cycle: 28.7  
 10th %ile Actuated Cycle: 14.5

Splits and Phases: 4: Shiloh Road & US 101 SB Off-Ramp



Lanes, Volumes, Timings  
5: Caletti Ave & Shiloh Road

Existing Conditions  
Timing Plan: A.M. PEAK



Lane Group	EBT	EBR	WBL	WBT	NBL	NBR
Lane Configurations	↑↑		↵	↑	↵	↵
Traffic Volume (vph)	518	22	177	547	7	121
Future Volume (vph)	518	22	177	547	7	121
Ideal Flow (vphpl)	1900	1900	1900	1900	1900	1900
Storage Length (ft)		0	68		0	0
Storage Lanes		0	1		1	1
Taper Length (ft)			50		25	
Lane Util. Factor	0.95	0.95	1.00	1.00	1.00	1.00
Frt	0.994					0.850
Flt Protected			0.950		0.950	
Satd. Flow (prot)	3518	0	1770	1863	1770	1583
Flt Permitted			0.950		0.950	
Satd. Flow (perm)	3518	0	1770	1863	1770	1583
Link Speed (mph)	40			40	30	
Link Distance (ft)	1081			184	459	
Travel Time (s)	18.4			3.1	10.4	
Peak Hour Factor	0.96	0.96	0.87	0.87	0.84	0.84
Adj. Flow (vph)	540	23	203	629	8	144
Shared Lane Traffic (%)						
Lane Group Flow (vph)	563	0	203	629	8	144
Enter Blocked Intersection	No	No	No	No	No	No
Lane Alignment	Left	Right	Left	Left	Left	Right
Median Width(ft)	12			12	12	
Link Offset(ft)	0			0	0	
Crosswalk Width(ft)	16			16	16	
Two way Left Turn Lane						
Headway Factor	1.00	1.00	1.00	1.00	1.00	1.00
Turning Speed (mph)		9	15		15	9
Sign Control	Free			Free	Stop	

Intersection Summary

Area Type:	Other
Control Type:	Unsignalized
Intersection Capacity Utilization	38.8%
ICU Level of Service	A
Analysis Period (min)	15

Lanes, Volumes, Timings  
6: Conde Lane & Shiloh Road

Existing Conditions  
Timing Plan: A.M. PEAK



Lane Group	EBL	EBT	EBR	WBL	WBT	WBR	NBL	NBT	NBR	SBL	SBT	SBR
Lane Configurations												
Traffic Volume (vph)	25	323	5	9	351	204	4	0	12	205	1	35
Future Volume (vph)	25	323	5	9	351	204	4	0	12	205	1	35
Ideal Flow (vphpl)	1900	1900	1900	1900	1900	1900	1900	1900	1900	1900	1900	1900
Storage Length (ft)	90		0	127		0	0		0	0		40
Storage Lanes	1		0	1		0	0		0	0		1
Taper Length (ft)	70			40			25			25		
Lane Util. Factor	1.00	0.95	0.95	1.00	0.95	0.95	1.00	1.00	1.00	1.00	1.00	1.00
Frt		0.998			0.945			0.899				0.850
Flt Protected	0.950			0.950				0.988			0.953	
Satd. Flow (prot)	1770	3532	0	1770	3345	0	0	1655	0	0	1775	1583
Flt Permitted	0.950			0.950				0.988			0.953	
Satd. Flow (perm)	1770	3532	0	1770	3345	0	0	1655	0	0	1775	1583
Right Turn on Red			Yes			Yes			Yes			No
Satd. Flow (RTOR)		1			120			89				
Link Speed (mph)		40			40			30				35
Link Distance (ft)		815			1081			418				522
Travel Time (s)		13.9			18.4			9.5				10.2
Peak Hour Factor	0.95	0.95	0.95	0.85	0.85	0.85	0.57	0.57	0.57	0.86	0.86	0.86
Adj. Flow (vph)	26	340	5	11	413	240	7	0	21	238	1	41
Shared Lane Traffic (%)												
Lane Group Flow (vph)	26	345	0	11	653	0	0	28	0	0	239	41
Enter Blocked Intersection	No	No	No	No	No	No	No	No	No	No	No	No
Lane Alignment	Left	Left	Right	Left	Left	Right	Left	Left	Right	Left	Left	Right
Median Width(ft)		12			12			0				0
Link Offset(ft)		0			0			0				0
Crosswalk Width(ft)		16			16			16				16
Two way Left Turn Lane												
Headway Factor	1.00	1.00	1.00	1.00	1.00	1.00	1.00	1.00	1.00	1.00	1.00	1.00
Turning Speed (mph)	15		9	15		9	15		9	15		9
Number of Detectors	1	2		1	2		1	2		1	1	1
Detector Template	Left	Thru		Left	Thru		Left	Thru		Left	Thru	Right
Leading Detector (ft)	20	100		20	100		20	100		20	30	20
Trailing Detector (ft)	0	0		0	0		0	0		0	0	0
Detector 1 Position(ft)	0	0		0	0		0	0		0	0	0
Detector 1 Size(ft)	20	6		20	6		20	6		20	30	20
Detector 1 Type	Cl+Ex	Cl+Ex		Cl+Ex	Cl+Ex		Cl+Ex	Cl+Ex		Cl+Ex	Cl+Ex	Cl+Ex
Detector 1 Channel												
Detector 1 Extend (s)	0.0	0.0		0.0	0.0		0.0	0.0		0.0	0.0	0.0
Detector 1 Queue (s)	0.0	0.0		0.0	0.0		0.0	0.0		0.0	0.0	0.0
Detector 1 Delay (s)	0.0	0.0		0.0	0.0		0.0	0.0		0.0	0.0	0.0
Detector 2 Position(ft)		94			94			94				
Detector 2 Size(ft)		6			6			6				
Detector 2 Type		Cl+Ex			Cl+Ex			Cl+Ex				
Detector 2 Channel												
Detector 2 Extend (s)		0.0			0.0			0.0				
Turn Type	Prot	NA		Prot	NA		Split	NA		Split	NA	custom
Protected Phases	5	2		1	6		7	7		4	4	
Permitted Phases												6



Lanes, Volumes, Timings  
6: Conde Lane & Shiloh Road

Existing Conditions  
Timing Plan: A.M. PEAK



Lane Group	EBL	EBT	EBR	WBL	WBT	WBR	NBL	NBT	NBR	SBL	SBT	SBR
Detector Phase	5	2		1	6		7	7		4	4	6
Switch Phase												
Minimum Initial (s)	8.0	8.0		8.0	8.0		10.0	10.0		11.0	11.0	8.0
Minimum Split (s)	12.0	46.0		12.0	12.0		37.0	37.0		15.0	15.0	12.0
Total Split (s)	13.0	46.0		12.0	45.0		37.0	37.0		15.0	15.0	45.0
Total Split (%)	11.8%	41.8%		10.9%	40.9%		33.6%	33.6%		13.6%	13.6%	40.9%
Maximum Green (s)	9.0	42.0		8.0	41.0		33.0	33.0		11.0	11.0	41.0
Yellow Time (s)	3.0	3.0		3.0	3.0		3.0	3.0		3.0	3.0	3.0
All-Red Time (s)	1.0	1.0		1.0	1.0		1.0	1.0		1.0	1.0	1.0
Lost Time Adjust (s)	0.0	0.0		0.0	0.0		0.0	0.0		0.0	0.0	0.0
Total Lost Time (s)	4.0	4.0		4.0	4.0		4.0	4.0		4.0	4.0	4.0
Lead/Lag	Lead	Lag		Lead	Lag							Lag
Lead-Lag Optimize?	Yes	Yes		Yes	Yes							Yes
Vehicle Extension (s)	3.0	3.0		3.0	3.0		3.0	3.0		3.0	3.0	3.0
Recall Mode	None	None		None	None		None	None		None	None	None
Walk Time (s)		7.0					7.0	7.0				
Flash Dont Walk (s)		35.0					26.0	26.0				
Pedestrian Calls (#/hr)		0					0	0				
Act Effct Green (s)	9.3	16.3		9.3	14.7			11.7			12.8	14.7
Actuated g/C Ratio	0.21	0.37		0.21	0.34			0.27			0.29	0.34
v/c Ratio	0.07	0.26		0.03	0.54			0.06			0.46	0.08
Control Delay	23.5	11.2		23.7	13.1			0.2			24.8	14.1
Queue Delay	0.0	0.0		0.0	0.0			0.0			0.0	0.0
Total Delay	23.5	11.2		23.7	13.1			0.2			24.8	14.1
LOS	C	B		C	B			A			C	B
Approach Delay		12.1			13.3			0.2			23.2	
Approach LOS		B			B			A			C	
90th %ile Green (s)	8.0	22.4		8.0	22.4		10.0	10.0		11.0	11.0	22.4
90th %ile Term Code	Min	Hold		Max	Gap		Min	Min		Max	Max	Gap
70th %ile Green (s)	8.0	30.5		0.0	18.5		10.0	10.0		11.0	11.0	18.5
70th %ile Term Code	Min	Hold		Skip	Gap		Min	Min		Max	Max	Gap
50th %ile Green (s)	0.0	13.1		0.0	13.1		0.0	0.0		11.0	11.0	13.1
50th %ile Term Code	Skip	Hold		Skip	Gap		Skip	Skip		Max	Max	Gap
30th %ile Green (s)	0.0	10.0		0.0	10.0		0.0	0.0		11.0	11.0	10.0
30th %ile Term Code	Skip	Hold		Skip	Gap		Skip	Skip		Max	Max	Gap
10th %ile Green (s)	0.0	8.0		0.0	8.0		0.0	0.0		11.0	11.0	8.0
10th %ile Term Code	Skip	Min		Skip	Min		Skip	Skip		Max	Max	Min

Intersection Summary

Area Type:	Other
Cycle Length:	110
Actuated Cycle Length:	43.8
Natural Cycle:	110
Control Type:	Actuated-Uncoordinated
Maximum v/c Ratio:	0.54
Intersection Signal Delay:	14.8
Intersection LOS:	B
Intersection Capacity Utilization:	45.5%
ICU Level of Service:	A
Analysis Period (min):	15
90th %ile Actuated Cycle:	67.4

Lanes, Volumes, Timings  
 6: Conde Lane & Shiloh Road

Existing Conditions  
 Timing Plan: A.M. PEAK

70th %ile Actuated Cycle: 63.5  
 50th %ile Actuated Cycle: 32.1  
 30th %ile Actuated Cycle: 29  
 10th %ile Actuated Cycle: 27

Splits and Phases: 6: Conde Lane & Shiloh Road

↙ Ø1 12 s	→ Ø2 46 s	↙ Ø4 15 s	↕ Ø7 37 s
↗ Ø5 13 s	← Ø6 45 s		



















Lanes, Volumes, Timings  
7: Entrance 1/Gridley Drive & Shiloh Road

Existing Conditions  
Timing Plan: A.M. PEAK

Lane Group	EBL	EBT	EBR	WBL	WBT	WBR	NBL	NBT	NBR	SBL	SBT	SBR	
Lane Configurations													
Traffic Volume (vph)	8	141	0	0	58	0	0	0	0	1	0	16	
Future Volume (vph)	8	141	0	0	58	0	0	0	0	1	0	16	
Ideal Flow (vphpl)	1900	1900	1900	1900	1900	1900	1900	1900	1900	1900	1900	1900	
Lane Util. Factor	1.00	1.00	1.00	1.00	1.00	1.00	1.00	1.00	1.00	1.00	1.00	1.00	
Ped Bike Factor													
Frt												0.871	
Flt Protected	0.997											0.998	
Satd. Flow (prot)	0	1857	0	0	1863	0	1863	1863	0	0	1619	0	
Flt Permitted	0.997											0.998	
Satd. Flow (perm)	0	1857	0	0	1863	0	1863	1863	0	0	1619	0	
Link Speed (mph)					40					30			30
Link Distance (ft)					608					2146			248
Travel Time (s)					10.4					36.6			5.6
Confl. Bikes (#/hr)			1										
Peak Hour Factor	0.91	0.91	0.91	0.85	0.85	0.85	1.00	1.00	1.00	0.71	0.71	0.71	
Adj. Flow (vph)	9	155	0	0	68	0	0	0	0	1	0	23	
Shared Lane Traffic (%)													
Lane Group Flow (vph)	0	164	0	0	68	0	0	0	0	0	24	0	
Enter Blocked Intersection	No	No	No	No	No	No	No	No	No	No	No	No	
Lane Alignment	Left	Left	Right	Left	Left	Right	Left	Left	Right	Left	Left	Right	
Median Width(ft)	0				0				12		12		
Link Offset(ft)	0				0				0		0		
Crosswalk Width(ft)	16				16				16		16		
Two way Left Turn Lane													
Headway Factor	1.00	1.00	1.00	1.00	1.00	1.00	1.00	1.00	1.00	1.00	1.00	1.00	
Turning Speed (mph)	15		9		15		9		15		9		
Sign Control	Free				Free				Stop		Stop		
<b>Intersection Summary</b>													
Area Type:	Other												
Control Type:	Unsignalized												
Intersection Capacity Utilization	24.0%						ICU Level of Service A						
Analysis Period (min)	15												











Lanes, Volumes, Timings  
8: Old Redwood Hwy & Entrance 1

Existing Conditions  
Timing Plan: A.M. PEAK

												
Lane Group	EBL	EBT	EBR	WBL	WBT	WBR	NBL	NBT	NBR	SBL	SBT	SBR
Lane Configurations												
Traffic Volume (vph)	1	0	0	0	0	0	0	217	0	0	316	0
Future Volume (vph)	1	0	0	0	0	0	0	217	0	0	316	0
Ideal Flow (vphp)	1900	1900	1900	1900	1900	1900	1900	1900	1900	1900	1900	1900
Storage Length (ft)	0		0	0		0	0		0	50		0
Storage Lanes	0		0	1		0	0		0	1		0
Taper Length (ft)	25			25			25			25		
Lane Util. Factor	1.00	1.00	1.00	1.00	1.00	1.00	1.00	1.00	1.00	1.00	1.00	1.00
Ped Bike Factor												
Fr <sub>t</sub>												
Fl <sub>t</sub> Protected		0.950										
Satd. Flow (prot)	0	1770	0	1863	1863	0	0	1863	0	1863	1863	0
Fl <sub>t</sub> Permitted		0.950										
Satd. Flow (perm)	0	1770	0	1863	1863	0	0	1863	0	1863	1863	0
Link Speed (mph)		30			30			45			45	
Link Distance (ft)		98			385			520			748	
Travel Time (s)		2.2			8.8			7.9			11.3	
Confl. Peds. (#/hr)									1	1		
Confl. Bikes (#/hr)									1			2
Peak Hour Factor	0.25	0.25	0.25	1.00	1.00	1.00	0.99	0.99	0.99	0.90	0.90	0.90
Adj. Flow (vph)	4	0	0	0	0	0	0	219	0	0	351	0
Shared Lane Traffic (%)												
Lane Group Flow (vph)	0	4	0	0	0	0	0	219	0	0	351	0
Enter Blocked Intersection	No	No	No	No	No	No	No	No	No	No	No	No
Lane Alignment	Left	Left	Right	Left	Left	Right	Left	Left	Right	Left	Left	Right
Median Width(ft)		12			12			12			12	
Link Offset(ft)		0			0			0			0	
Crosswalk Width(ft)		16			16			16			16	
Two way Left Turn Lane												
Headway Factor	1.00	1.00	1.00	1.00	1.00	1.00	1.00	1.00	1.00	1.00	1.00	1.00
Turning Speed (mph)	15		9	15		9	15		9	15		9
Sign Control		Stop			Stop			Free			Free	
<b>Intersection Summary</b>												
Area Type:	Other											
Control Type:	Unsignalized											
Intersection Capacity Utilization	26.6%						ICU Level of Service A					
Analysis Period (min)	15											

Lanes, Volumes, Timings  
9: Entrance 2 & Shiloh Road

Existing Conditions  
Timing Plan: A.M. PEAK

						
Lane Group	EBT	EBR	WBL	WBT	NBL	NBR
Lane Configurations						
Traffic Volume (vph)	140	0	0	52	0	0
Future Volume (vph)	140	0	0	52	0	0
Ideal Flow (vphp)	1900	1900	1900	1900	1900	1900
Lane Util. Factor	1.00	1.00	1.00	1.00	1.00	1.00
<b>Fr</b>						
Flt Protected						
Satd. Flow (prot)	1863	0	0	1863	1863	1863
Flt Permitted						
Satd. Flow (perm)	1863	0	0	1863	1863	1863
Link Speed (mph)	40			40	30	
Link Distance (ft)	2146			134	402	
Travel Time (s)	36.6			2.3	9.1	
Peak Hour Factor	0.85	0.85	0.81	0.81	1.00	1.00
Adj. Flow (vph)	165	0	0	64	0	0
Shared Lane Traffic (%)						
Lane Group Flow (vph)	165	0	0	64	0	0
Enter Blocked Intersection	No	No	No	No	No	No
Lane Alignment	Left	Right	Left	Left	Left	Right
Median Width(ft)	0			0	12	
Link Offset(ft)	0			0	0	
Crosswalk Width(ft)	16			16	16	
Two way Left Turn Lane						
Headway Factor	1.00	1.00	1.00	1.00	1.00	1.00
Turning Speed (mph)		9	15		15	9
Sign Control	Free			Free	Stop	
<b>Intersection Summary</b>						
Area Type:	Other					
Control Type:	Unsignalized					
Intersection Capacity Utilization	10.7%			ICU Level of Service A		
Analysis Period (min)	15					

Lanes, Volumes, Timings  
 10: US 101 NB Off Ramp/Lakewood Drive & Old Redwood Highway

Existing Conditions  
 Timing Plan: A.M. PEAK



Lane Group	EBL	EBT	EBR	WBL	WBT	WBR	NBL	NBT	NBR	SBL	SBT	SBR
Lane Configurations	↖↗	↑			↖↗		↖	↖↗		↖↗		↖
Traffic Volume (vph)	152	149	0	0	440	149	227	221	79	118	0	534
Future Volume (vph)	152	149	0	0	440	149	227	221	79	118	0	534
Ideal Flow (vphpl)	1900	1900	1900	1900	1900	1900	1900	1900	1900	1900	1900	1900
Storage Length (ft)	155		0	0		0	270		150	120		0
Storage Lanes	1		0	0		0	1		1	1		1
Taper Length (ft)	50			25			165			75		
Lane Util. Factor	0.97	1.00	1.00	1.00	0.95	0.95	0.91	0.91	0.95	0.97	1.00	1.00
Ped Bike Factor	1.00				1.00			1.00		1.00		
Fr <sub>t</sub>					0.962			0.966				0.850
Fl <sub>t</sub> Protected	0.950						0.950	0.993		0.950		
Satd. Flow (prot)	3433	1863	0	0	3393	0	1610	3242	0	3433	0	1583
Fl <sub>t</sub> Permitted	0.950						0.950	0.993		0.950		
Satd. Flow (perm)	3431	1863	0	0	3393	0	1610	3242	0	3427	0	1583
Right Turn on Red			Yes			Yes			Yes			Yes
Satd. Flow (RTOR)					53			41				308
Link Speed (mph)		35			35			30				30
Link Distance (ft)		226			617			716				478
Travel Time (s)		4.4			12.0			16.3				10.9
Confl. Peds. (#/hr)	1		1	1		1			2	2		
Confl. Bikes (#/hr)			1			1						
Peak Hour Factor	0.85	0.85	0.85	0.83	0.83	0.83	0.90	0.90	0.90	0.89	0.89	0.89
Adj. Flow (vph)	179	175	0	0	530	180	252	246	88	133	0	600
Shared Lane Traffic (%)							23%					
Lane Group Flow (vph)	179	175	0	0	710	0	194	392	0	133	0	600
Enter Blocked Intersection	No	No	No	No	No	No	No	No	No	No	No	No
Lane Alignment	Left	Left	Right	Left	Left	Right	Left	Left	Right	Left	Left	Right
Median Width(ft)		24			24			24				24
Link Offset(ft)		0			0			0				0
Crosswalk Width(ft)		16			16			16				16
Two way Left Turn Lane												
Headway Factor	1.00	1.00	1.00	1.00	1.00	1.00	1.00	1.00	1.00	1.00	1.00	1.00
Turning Speed (mph)	15		9	15		9	15		9	15		9
Number of Detectors	1	2			2		1	2		1		1
Detector Template	Left	Thru			Thru		Left	Thru		Left		Right
Leading Detector (ft)	20	100			100		20	100		20		20
Trailing Detector (ft)	0	0			0		0	0		0		0
Detector 1 Position(ft)	0	0			0		0	0		0		0
Detector 1 Size(ft)	20	6			6		20	6		20		20
Detector 1 Type	Cl+Ex	Cl+Ex			Cl+Ex		Cl+Ex	Cl+Ex		Cl+Ex		Cl+Ex
Detector 1 Channel												
Detector 1 Extend (s)	0.0	0.0			0.0		0.0	0.0		0.0		0.0
Detector 1 Queue (s)	0.0	0.0			0.0		0.0	0.0		0.0		0.0
Detector 1 Delay (s)	0.0	0.0			0.0		0.0	0.0		0.0		0.0
Detector 2 Position(ft)		94			94			94				
Detector 2 Size(ft)		6			6			6				
Detector 2 Type		Cl+Ex			Cl+Ex			Cl+Ex				
Detector 2 Channel												
Detector 2 Extend (s)		0.0			0.0			0.0				

Lanes, Volumes, Timings  
 10: US 101 NB Off Ramp/Lakewood Drive & Old Redwood Highway

Existing Conditions  
 Timing Plan: A.M. PEAK



Lane Group	EBL	EBT	EBR	WBL	WBT	WBR	NBL	NBT	NBR	SBL	SBT	SBR
Turn Type	Prot	NA			NA		Split	NA		Prot		pm+ov
Protected Phases	5	2			6		8	8		7		5
Permitted Phases												5 8
Detector Phase	5	2			6		8	8		7		5
Switch Phase												
Minimum Initial (s)	7.0	10.0			10.0		10.0	10.0		7.0		7.0
Minimum Split (s)	11.0	32.1			32.1		33.7	33.7		11.0		11.0
Total Split (s)	13.0	45.3			32.3		33.7	33.7		11.0		13.0
Total Split (%)	14.4%	50.3%			35.9%		37.4%	37.4%		12.2%		14.4%
Maximum Green (s)	9.0	40.2			27.2		29.0	29.0		7.0		9.0
Yellow Time (s)	3.0	4.1			4.1		3.7	3.7		3.0		3.0
All-Red Time (s)	1.0	1.0			1.0		1.0	1.0		1.0		1.0
Lost Time Adjust (s)	0.0	0.0			0.0		0.0	0.0		0.0		0.0
Total Lost Time (s)	4.0	5.1			5.1		4.7	4.7		4.0		4.0
Lead/Lag	Lead				Lag		Lag	Lag		Lead		Lead
Lead-Lag Optimize?	Yes				Yes		Yes	Yes		Yes		Yes
Vehicle Extension (s)	3.0	3.0			3.0		3.0	3.0		3.0		3.0
Recall Mode	None	Max			Max		None	None		None		None
Walk Time (s)		7.0			7.0		7.0	7.0				
Flash Dont Walk (s)		20.0			17.0		22.0	22.0				
Pedestrian Calls (#/hr)		0			0		0	0				
Act Effct Green (s)	8.4	40.3			27.9		15.8	15.8		7.0		28.9
Actuated g/C Ratio	0.11	0.52			0.36		0.21	0.21		0.09		0.38
v/c Ratio	0.48	0.18			0.56		0.59	0.56		0.42		0.76
Control Delay	37.6	11.3			21.1		35.0	27.4		38.9		16.6
Queue Delay	0.0	0.0			0.0		0.0	0.0		0.0		0.0
Total Delay	37.6	11.3			21.1		35.0	27.4		38.9		16.6
LOS	D	B			C		D	C		D		B
Approach Delay		24.6			21.1			29.9			20.7	
Approach LOS		C			C			C			C	
90th %ile Green (s)	9.0	40.2			27.2		23.4	23.4		7.0		9.0
90th %ile Term Code	Max	MaxR			MaxR		Gap	Gap		Max		Max
70th %ile Green (s)	9.0	40.2			27.2		18.6	18.6		7.0		9.0
70th %ile Term Code	Max	MaxR			MaxR		Gap	Gap		Max		Max
50th %ile Green (s)	9.0	40.2			27.2		15.1	15.1		7.0		9.0
50th %ile Term Code	Max	MaxR			MaxR		Gap	Gap		Max		Max
30th %ile Green (s)	8.2	40.2			28.0		12.9	12.9		7.0		8.2
30th %ile Term Code	Gap	MaxR			Hold		Gap	Gap		Max		Gap
10th %ile Green (s)	7.0	40.2			29.2		10.0	10.0		7.0		7.0
10th %ile Term Code	Min	MaxR			Hold		Min	Min		Max		Min

Intersection Summary

Area Type:	Other
Cycle Length:	90
Actuated Cycle Length:	77
Natural Cycle:	90
Control Type:	Actuated-Uncoordinated
Maximum v/c Ratio:	0.76
Intersection Signal Delay:	23.7
Intersection LOS:	C

Lanes, Volumes, Timings  
 10: US 101 NB Off Ramp/Lakewood Drive & Old Redwood Highway

Existing Conditions  
 Timing Plan: A.M. PEAK

Intersection Capacity Utilization 75.7%	ICU Level of Service D
Analysis Period (min) 15	
90th %ile Actuated Cycle: 84.4	
70th %ile Actuated Cycle: 79.6	
50th %ile Actuated Cycle: 76.1	
30th %ile Actuated Cycle: 73.9	
10th %ile Actuated Cycle: 71	

Splits and Phases: 10: US 101 NB Off Ramp/Lakewood Drive & Old Redwood Highway

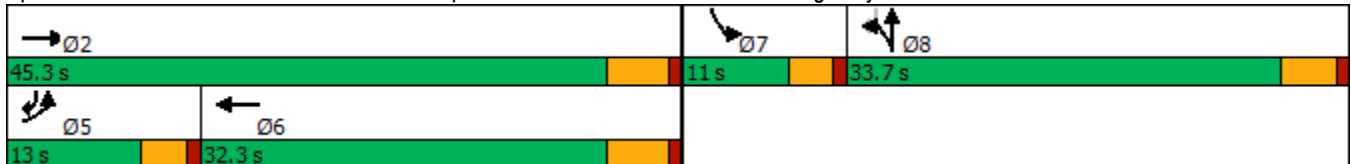



Lanes, Volumes, Timings  
 11: Old Redwood Highway & US 101 NB On Ramp

Existing Conditions  
 Timing Plan: A.M. PEAK



Lane Group	EBL	EBT	WBT	WBR	SBL	SBR
Lane Configurations						
Traffic Volume (vph)	86	299	1012	190	0	0
Future Volume (vph)	86	299	1012	190	0	0
Ideal Flow (vphpl)	1900	1900	1900	1900	1900	1900
Storage Length (ft)	245			0	0	0
Storage Lanes	1			0	0	0
Taper Length (ft)	50				25	
Lane Util. Factor	1.00	0.95	0.95	0.95	1.00	1.00
Ped Bike Factor						
Frt			0.976			
Flt Protected	0.950					
Satd. Flow (prot)	1770	3539	3454	0	0	0
Flt Permitted	0.950					
Satd. Flow (perm)	1770	3539	3454	0	0	0
Link Speed (mph)		35	35		30	
Link Distance (ft)		531	226		299	
Travel Time (s)		10.3	4.4		6.8	
Confl. Peds. (#/hr)	9					
Confl. Bikes (#/hr)				1		
Peak Hour Factor	0.81	0.81	0.89	0.89	0.25	0.25
Adj. Flow (vph)	106	369	1137	213	0	0
Shared Lane Traffic (%)						
Lane Group Flow (vph)	106	369	1350	0	0	0
Enter Blocked Intersection	No	No	No	No	No	No
Lane Alignment	Left	Left	Left	Right	Left	Right
Median Width(ft)		12	12		0	
Link Offset(ft)		0	0		0	
Crosswalk Width(ft)		16	16		16	
Two way Left Turn Lane						
Headway Factor	1.00	1.00	1.00	1.00	1.00	1.00
Turning Speed (mph)	15			9	15	9
Sign Control		Free	Free		Free	

Intersection Summary	
Area Type:	Other
Control Type:	Unsignalized
Intersection Capacity Utilization	70.8% ICU Level of Service C
Analysis Period (min)	15

Lanes, Volumes, Timings

12: US 101 SB On Ramp/US 101 SB Off Ramp & Old Redwood Highway

Existing Conditions

Timing Plan: A.M. PEAK

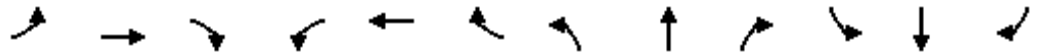

Lane Group	EBL	EBT	EBR	WBL	WBT	WBR	NBL	NBT	NBR	SBL	SBT	SBR
Lane Configurations		↑↑	↗	↖	↑↑					↖	↕	
Traffic Volume (vph)	0	298	296	513	504	0	0	0	0	92	1	65
Future Volume (vph)	0	298	296	513	504	0	0	0	0	92	1	65
Ideal Flow (vphpl)	1900	1900	1900	1900	1900	1900	1900	1900	1900	1900	1900	1900
Storage Length (ft)	0		0	250		0	0		0	420		0
Storage Lanes	0		1	0		0	0		0	1		0
Taper Length (ft)	25			165			25			75		
Lane Util. Factor	1.00	0.95	1.00	1.00	0.95	1.00	1.00	1.00	1.00	0.95	0.95	1.00
Ped Bike Factor			0.98	1.00								
Frt			0.850								0.870	
Flt Protected				0.950						0.950	0.994	
Satd. Flow (prot)	0	3539	1583	1770	3539	0	0	0	0	1681	1530	0
Flt Permitted				0.950						0.950	0.994	
Satd. Flow (perm)	0	3539	1558	1767	3539	0	0	0	0	1681	1530	0
Right Turn on Red			Yes			Yes			Yes			Yes
Satd. Flow (RTOR)			322								80	
Link Speed (mph)		35			35			30			30	
Link Distance (ft)		423			531			621			831	
Travel Time (s)		8.2			10.3			14.1			18.9	
Confl. Peds. (#/hr)	10		3	3		10						
Confl. Bikes (#/hr)			2									
Peak Hour Factor	0.92	0.92	0.92	0.89	0.89	0.89	0.25	0.25	0.25	0.81	0.81	0.81
Adj. Flow (vph)	0	324	322	576	566	0	0	0	0	114	1	80
Shared Lane Traffic (%)										10%		
Lane Group Flow (vph)	0	324	322	576	566	0	0	0	0	103	92	0
Enter Blocked Intersection	No	No	No	No	No	No	No	No	No	No	No	No
Lane Alignment	Left	Left	Right	Left	Left	Right	Left	Left	Right	Left	Left	Right
Median Width(ft)		24			24			12			12	
Link Offset(ft)		0			0			0			0	
Crosswalk Width(ft)		16			16			16			16	
Two way Left Turn Lane												
Headway Factor	1.00	1.00	1.00	1.00	1.00	1.00	1.00	1.00	1.00	1.00	1.00	1.00
Turning Speed (mph)	15		9	15		9	15		9	15		9
Number of Detectors		2	1	1	2					1	2	
Detector Template		Thru	Right	Left	Thru					Left	Thru	
Leading Detector (ft)		100	20	20	100					20	100	
Trailing Detector (ft)		0	0	0	0					0	0	
Detector 1 Position(ft)		0	0	0	0					0	0	
Detector 1 Size(ft)		6	20	20	6					20	6	
Detector 1 Type		Cl+Ex	Cl+Ex	Cl+Ex	Cl+Ex					Cl+Ex	Cl+Ex	
Detector 1 Channel												
Detector 1 Extend (s)		0.0	0.0	0.0	0.0					0.0	0.0	
Detector 1 Queue (s)		0.0	0.0	0.0	0.0					0.0	0.0	
Detector 1 Delay (s)		0.0	0.0	0.0	0.0					0.0	0.0	
Detector 2 Position(ft)		94			94							94
Detector 2 Size(ft)		6			6							6
Detector 2 Type		Cl+Ex			Cl+Ex							Cl+Ex
Detector 2 Channel												
Detector 2 Extend (s)		0.0			0.0							0.0

Lanes, Volumes, Timings

Existing Conditions

12: US 101 SB On Ramp/US 101 SB Off Ramp & Old Redwood Highway

Timing Plan: A.M. PEAK

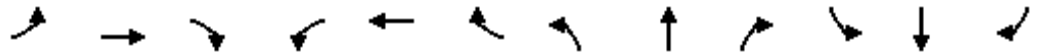

Lane Group	EBL	EBT	EBR	WBL	WBT	WBR	NBL	NBT	NBR	SBL	SBT	SBR
Turn Type		NA	Perm	Prot	NA					Perm	NA	
Protected Phases		6		5	2						8	
Permitted Phases			6							8		
Detector Phase		6	6	5	2					8	8	
Switch Phase												
Minimum Initial (s)		10.0	10.0	7.0	10.0					10.0	10.0	
Minimum Split (s)		32.1	32.1	11.0	38.1					14.7	14.7	
Total Split (s)		32.3	32.3	33.0	65.3					14.7	14.7	
Total Split (%)		40.4%	40.4%	41.3%	81.6%					18.4%	18.4%	
Maximum Green (s)		27.2	27.2	29.0	60.2					10.0	10.0	
Yellow Time (s)		4.1	4.1	3.0	4.1					3.7	3.7	
All-Red Time (s)		1.0	1.0	1.0	1.0					1.0	1.0	
Lost Time Adjust (s)		0.0	0.0	0.0	0.0					0.0	0.0	
Total Lost Time (s)		5.1	5.1	4.0	5.1					4.7	4.7	
Lead/Lag		Lag	Lag	Lead								
Lead-Lag Optimize?		Yes	Yes	Yes								
Vehicle Extension (s)		3.0	3.0	3.0	3.0					3.0	3.0	
Recall Mode		Max	Max	None	Max					None	None	
Walk Time (s)		7.0	7.0		7.0							
Flash Dont Walk (s)		20.0	20.0		25.0							
Pedestrian Calls (#/hr)		0	0		0							
Act Effct Green (s)		29.4	29.4	27.2	61.8					10.1	10.1	
Actuated g/C Ratio		0.38	0.38	0.35	0.80					0.13	0.13	
v/c Ratio		0.24	0.41	0.92	0.20					0.47	0.34	
Control Delay		18.7	4.2	47.4	2.8					40.4	14.3	
Queue Delay		0.0	0.0	0.0	0.0					0.0	0.0	
Total Delay		18.7	4.2	47.4	2.8					40.4	14.3	
LOS		B	A	D	A					D	B	
Approach Delay		11.5			25.3						28.1	
Approach LOS		B			C						C	
90th %ile Green (s)		27.2	27.2	29.0	60.2					10.0	10.0	
90th %ile Term Code		MaxR	MaxR	Max	MaxR					Max	Max	
70th %ile Green (s)		27.2	27.2	29.0	60.2					10.0	10.0	
70th %ile Term Code		MaxR	MaxR	Max	MaxR					Max	Max	
50th %ile Green (s)		27.2	27.2	29.0	60.2					10.0	10.0	
50th %ile Term Code		MaxR	MaxR	Max	MaxR					Max	Max	
30th %ile Green (s)		27.2	27.2	29.0	60.2					10.0	10.0	
30th %ile Term Code		MaxR	MaxR	Max	MaxR					Max	Max	
10th %ile Green (s)		35.8	35.8	20.4	60.2					0.0	0.0	
10th %ile Term Code		Hold	Hold	Gap	MaxR					Skip	Skip	

Intersection Summary

Area Type:	Other
Cycle Length:	80
Actuated Cycle Length:	77.1
Natural Cycle:	80
Control Type:	Actuated-Uncoordinated
Maximum v/c Ratio:	0.92
Intersection Signal Delay:	21.1
Intersection LOS:	C

Lanes, Volumes, Timings

Existing Conditions

12: US 101 SB On Ramp/US 101 SB Off Ramp & Old Redwood Highway

Timing Plan: A.M. PEAK





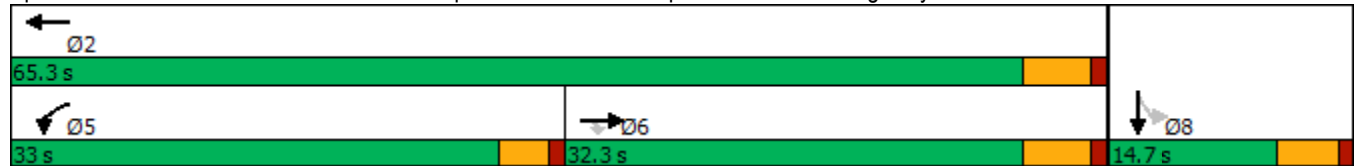

















Intersection Capacity Utilization 70.8%	ICU Level of Service C
Analysis Period (min) 15	
90th %ile Actuated Cycle: 80	
70th %ile Actuated Cycle: 80	
50th %ile Actuated Cycle: 80	
30th %ile Actuated Cycle: 80	
10th %ile Actuated Cycle: 65.3	

Splits and Phases: 12: US 101 SB On Ramp/US 101 SB Off Ramp & Old Redwood Highway



Lanes, Volumes, Timings  
1: Old Redwood Hwy & Shiloh Road

Existing Conditions  
Timing Plan: P.M. Peak

												
Lane Group	EBL	EBT	EBR	WBL	WBT	WBR	NBL	NBT	NBR	SBL	SBT	SBR
Lane Configurations												
Traffic Volume (vph)	241	83	160	37	78	16	140	337	21	23	233	146
Future Volume (vph)	241	83	160	37	78	16	140	337	21	23	233	146
Ideal Flow (vphpl)	1900	1900	1900	1900	1900	1900	1900	1900	1900	1900	1900	1900
Storage Length (ft)	375		140	0		50	200		98	130		93
Storage Lanes	1		1	0		1	1		1	1		1
Taper Length (ft)	50			25			60			93		
Lane Util. Factor	1.00	1.00	1.00	1.00	1.00	1.00	1.00	1.00	1.00	1.00	1.00	1.00
Ped Bike Factor	1.00					0.98	1.00		0.98			0.97
Frt			0.850			0.850			0.850			0.850
Flt Protected	0.950				0.984		0.950			0.950		
Satd. Flow (prot)	1770	1863	1583	0	1833	1583	1770	1863	1583	1770	1863	1583
Flt Permitted	0.950				0.984		0.950			0.950		
Satd. Flow (perm)	1767	1863	1583	0	1833	1549	1767	1863	1546	1770	1863	1542
Right Turn on Red			Yes			Yes			Yes			Yes
Satd. Flow (RTOR)			165			105			77			106
Link Speed (mph)		40			40			45				40
Link Distance (ft)		1789			608			748				775
Travel Time (s)		30.5			10.4			11.3				13.2
Confl. Peds. (#/hr)	1						1	1				1
Confl. Bikes (#/hr)									3			3
Peak Hour Factor	0.97	0.97	0.97	0.91	0.91	0.91	0.93	0.93	0.93	0.93	0.93	0.93
Adj. Flow (vph)	248	86	165	41	86	18	151	362	23	25	251	157
Shared Lane Traffic (%)												
Lane Group Flow (vph)	248	86	165	0	127	18	151	362	23	25	251	157
Enter Blocked Intersection	No	No	No	No	No	No	No	No	No	No	No	No
Lane Alignment	Left	Left	Right	Left	Left	Right	Left	Left	Right	Left	Left	Right
Median Width(ft)		12			12			12				12
Link Offset(ft)		0			0			0				0
Crosswalk Width(ft)		16			16			16				16
Two way Left Turn Lane												
Headway Factor	1.00	1.00	1.00	1.00	1.00	1.00	1.00	1.00	1.00	1.00	1.00	1.00
Turning Speed (mph)	15		9	15		9	15		9	15		9
Number of Detectors	1	2	1	1	2	1	1	2	1	1	2	1
Detector Template	Left	Thru	Right	Left	Thru	Right	Left	Thru	Right	Left	Thru	Right
Leading Detector (ft)	20	100	20	20	100	20	20	100	20	20	100	20
Trailing Detector (ft)	0	0	0	0	0	0	0	0	0	0	0	0
Detector 1 Position(ft)	0	0	0	0	0	0	0	0	0	0	0	0
Detector 1 Size(ft)	20	6	20	20	6	20	20	6	20	20	6	20
Detector 1 Type	Cl+Ex	Cl+Ex	Cl+Ex	Cl+Ex	Cl+Ex	Cl+Ex	Cl+Ex	Cl+Ex	Cl+Ex	Cl+Ex	Cl+Ex	Cl+Ex
Detector 1 Channel												
Detector 1 Extend (s)	0.0	0.0	0.0	0.0	0.0	0.0	0.0	0.0	0.0	0.0	0.0	0.0
Detector 1 Queue (s)	0.0	0.0	0.0	0.0	0.0	0.0	0.0	0.0	0.0	0.0	0.0	0.0
Detector 1 Delay (s)	0.0	0.0	0.0	0.0	0.0	0.0	0.0	0.0	0.0	0.0	0.0	0.0
Detector 2 Position(ft)		94			94			94				94
Detector 2 Size(ft)		6			6			6				6
Detector 2 Type		Cl+Ex			Cl+Ex			Cl+Ex				Cl+Ex
Detector 2 Channel												
Detector 2 Extend (s)		0.0			0.0			0.0				0.0

Lanes, Volumes, Timings  
1: Old Redwood Hwy & Shiloh Road

Existing Conditions  
Timing Plan: P.M. Peak



Lane Group	EBL	EBT	EBR	WBL	WBT	WBR	NBL	NBT	NBR	SBL	SBT	SBR
Turn Type	Split	NA	Perm	Split	NA	Perm	Prot	NA	Perm	Prot	NA	Perm
Protected Phases	2	2		6	6		3	8		7	4	
Permitted Phases			2			6			8			4
Detector Phase	2	2	2	6	6	6	3	8	8	7	4	4
Switch Phase												
Minimum Initial (s)	5.0	5.0	5.0	5.0	5.0	5.0	5.0	5.0	5.0	5.0	5.0	5.0
Minimum Split (s)	34.5	34.5	34.5	42.5	42.5	42.5	8.5	46.5	46.5	8.5	39.5	39.5
Total Split (s)	35.0	35.0	35.0	42.5	42.5	42.5	18.0	48.0	48.0	9.5	39.5	39.5
Total Split (%)	25.9%	25.9%	25.9%	31.5%	31.5%	31.5%	13.3%	35.6%	35.6%	7.0%	29.3%	29.3%
Maximum Green (s)	30.5	30.5	30.5	38.0	38.0	38.0	14.5	43.5	43.5	6.0	35.0	35.0
Yellow Time (s)	3.5	3.5	3.5	3.5	3.5	3.5	3.0	3.5	3.5	3.0	3.5	3.5
All-Red Time (s)	1.0	1.0	1.0	1.0	1.0	1.0	0.5	1.0	1.0	0.5	1.0	1.0
Lost Time Adjust (s)	0.0	0.0	0.0		0.0	0.0	0.0	0.0	0.0	0.0	0.0	0.0
Total Lost Time (s)	4.5	4.5	4.5		4.5	4.5	3.5	4.5	4.5	3.5	4.5	4.5
Lead/Lag	Lead	Lead	Lead	Lag	Lag	Lag	Lead	Lag	Lag	Lead	Lag	Lag
Lead-Lag Optimize?	Yes	Yes	Yes	Yes	Yes	Yes	Yes	Yes	Yes	Yes	Yes	Yes
Vehicle Extension (s)	3.0	3.0	3.0	3.0	3.0	3.0	3.0	3.0	3.0	3.0	3.0	3.0
Recall Mode	None	None	None	None	None	None	None	None	None	None	None	None
Walk Time (s)	7.0	7.0	7.0	7.0	7.0	7.0		7.0	7.0		7.0	7.0
Flash Dont Walk (s)	23.0	23.0	23.0	31.0	31.0	31.0		35.0	35.0		28.0	28.0
Pedestrian Calls (#/hr)	0	0	0	0	0	0		0	0		0	0
Act Effct Green (s)	17.4	17.4	17.4		11.5	11.5	12.7	30.0	30.0	6.1	16.7	16.7
Actuated g/C Ratio	0.23	0.23	0.23		0.15	0.15	0.17	0.39	0.39	0.08	0.22	0.22
v/c Ratio	0.62	0.20	0.34		0.46	0.06	0.51	0.49	0.04	0.18	0.61	0.37
Control Delay	35.3	27.4	7.0		38.9	0.3	40.0	23.4	0.1	43.4	35.9	13.9
Queue Delay	0.0	0.0	0.0		0.0	0.0	0.0	0.0	0.0	0.0	0.0	0.0
Total Delay	35.3	27.4	7.0		38.9	0.3	40.0	23.4	0.1	43.4	35.9	13.9
LOS	D	C	A		D	A	D	C	A	D	D	B
Approach Delay		24.6			34.1			27.1			28.4	
Approach LOS		C			C			C			C	
90th %ile Green (s)	27.9	27.9	27.9	17.2	17.2	17.2	14.5	34.4	34.4	6.0	25.9	25.9
90th %ile Term Code	Gap	Gap	Gap	Gap	Gap	Gap	Max	Hold	Hold	Max	Gap	Gap
70th %ile Green (s)	20.9	20.9	20.9	13.6	13.6	13.6	14.5	28.2	28.2	6.0	19.7	19.7
70th %ile Term Code	Gap	Gap	Gap	Gap	Gap	Gap	Max	Hold	Hold	Max	Gap	Gap
50th %ile Green (s)	16.6	16.6	16.6	11.3	11.3	11.3	13.6	33.4	33.4	0.0	16.3	16.3
50th %ile Term Code	Gap	Gap	Gap	Gap	Gap	Gap	Gap	Hold	Hold	Skip	Gap	Gap
30th %ile Green (s)	13.7	13.7	13.7	9.4	9.4	9.4	11.3	28.3	28.3	0.0	13.5	13.5
30th %ile Term Code	Gap	Gap	Gap	Gap	Gap	Gap	Gap	Hold	Hold	Skip	Gap	Gap
10th %ile Green (s)	10.2	10.2	10.2	7.2	7.2	7.2	8.8	22.4	22.4	0.0	10.1	10.1
10th %ile Term Code	Gap	Gap	Gap	Gap	Gap	Gap	Gap	Hold	Hold	Skip	Gap	Gap

Intersection Summary

Area Type:	Other
Cycle Length:	135
Actuated Cycle Length:	76.2
Natural Cycle:	135
Control Type:	Actuated-Uncoordinated
Maximum v/c Ratio:	0.62
Intersection Signal Delay:	27.3
Intersection LOS:	C

Lanes, Volumes, Timings  
 1: Old Redwood Hwy & Shiloh Road

Existing Conditions  
 Timing Plan: P.M. Peak

Intersection Capacity Utilization 52.8%	ICU Level of Service A
Analysis Period (min) 15	
90th %ile Actuated Cycle: 102.5	
70th %ile Actuated Cycle: 85.7	
50th %ile Actuated Cycle: 74.8	
30th %ile Actuated Cycle: 64.9	
10th %ile Actuated Cycle: 53.3	

Splits and Phases: 1: Old Redwood Hwy & Shiloh Road

 Ø2	 Ø6	 Ø3	 Ø4
35 s	42.5 s	18 s	39.5 s
		 Ø7	 Ø8
		9.5 s	48 s

Lanes, Volumes, Timings  
2: Shiloh Road & Hembree Ln

Existing Conditions  
Timing Plan: P.M. Peak



Lane Group	EBL	EBT	WBT	WBR	SBL	SBR
Lane Configurations	↶↶	↶	↶↶		↶	↶
Traffic Volume (vph)	615	333	248	141	170	491
Future Volume (vph)	615	333	248	141	170	491
Ideal Flow (vphpl)	1900	1900	1900	1900	1900	1900
Storage Length (ft)	0			130	0	0
Storage Lanes	2			1	1	1
Taper Length (ft)	25				25	
Lane Util. Factor	0.97	1.00	0.95	0.95	1.00	1.00
Ped Bike Factor	1.00		1.00			
Frt			0.946			0.850
Flt Protected	0.950				0.950	
Satd. Flow (prot)	3433	1863	3332	0	1770	1583
Flt Permitted	0.950				0.950	
Satd. Flow (perm)	3429	1863	3332	0	1770	1583
Right Turn on Red				Yes		Yes
Satd. Flow (RTOR)			160			471
Link Speed (mph)		40	40		35	
Link Distance (ft)		302	1789		381	
Travel Time (s)		5.1	30.5		7.4	
Confl. Peds. (#/hr)	2			2		
Peak Hour Factor	0.94	0.94	0.87	0.87	0.95	0.95
Adj. Flow (vph)	654	354	285	162	179	517
Shared Lane Traffic (%)						
Lane Group Flow (vph)	654	354	447	0	179	517
Enter Blocked Intersection	No	No	No	No	No	No
Lane Alignment	Left	Left	Left	Right	Left	Right
Median Width(ft)		24	24		12	
Link Offset(ft)		0	0		0	
Crosswalk Width(ft)		16	16		16	
Two way Left Turn Lane						
Headway Factor	1.00	1.00	1.00	1.00	1.00	1.00
Turning Speed (mph)	15			9	15	9
Number of Detectors	1	2	2		1	1
Detector Template	Left	Thru	Thru		Left	Right
Leading Detector (ft)	20	100	100		20	20
Trailing Detector (ft)	0	0	0		0	0
Detector 1 Position(ft)	0	0	0		0	0
Detector 1 Size(ft)	20	6	6		20	20
Detector 1 Type	Cl+Ex	Cl+Ex	Cl+Ex		Cl+Ex	Cl+Ex
Detector 1 Channel						
Detector 1 Extend (s)	0.0	0.0	0.0		0.0	0.0
Detector 1 Queue (s)	0.0	0.0	0.0		0.0	0.0
Detector 1 Delay (s)	0.0	0.0	0.0		0.0	0.0
Detector 2 Position(ft)		94	94			
Detector 2 Size(ft)		6	6			
Detector 2 Type		Cl+Ex	Cl+Ex			
Detector 2 Channel						
Detector 2 Extend (s)		0.0	0.0			
Turn Type	Prot	NA	NA		Perm	pm+ov



Lanes, Volumes, Timings  
2: Shiloh Road & Hembree Ln

Existing Conditions  
Timing Plan: P.M. Peak



Lane Group	EBL	EBT	WBT	WBR	SBL	SBR
Protected Phases	5	2	6			5
Permitted Phases					4	4 5
Detector Phase	5	2	6		4	5
Switch Phase						
Minimum Initial (s)	3.0	5.0	5.0		5.0	3.0
Minimum Split (s)	7.0	9.0	43.0		9.0	7.0
Total Split (s)	29.0	73.0	44.0		17.0	29.0
Total Split (%)	32.2%	81.1%	48.9%		18.9%	32.2%
Maximum Green (s)	25.0	69.0	40.0		13.0	25.0
Yellow Time (s)	3.0	3.0	3.0		3.0	3.0
All-Red Time (s)	1.0	1.0	1.0		1.0	1.0
Lost Time Adjust (s)	0.0	0.0	0.0		0.0	0.0
Total Lost Time (s)	4.0	4.0	4.0		4.0	4.0
Lead/Lag	Lead		Lag			Lead
Lead-Lag Optimize?	Yes		Yes			Yes
Vehicle Extension (s)	3.0	3.0	3.0		3.0	3.0
Recall Mode	None	None	None		None	None
Walk Time (s)			7.0			
Flash Dont Walk (s)			32.0			
Pedestrian Calls (#/hr)			0			
Act Effct Green (s)	16.6	31.4	10.6		10.9	31.6
Actuated g/C Ratio	0.33	0.62	0.21		0.22	0.63
v/c Ratio	0.58	0.31	0.54		0.47	0.44
Control Delay	16.8	5.3	14.7		24.0	2.1
Queue Delay	0.0	0.0	0.0		0.0	0.0
Total Delay	16.8	5.3	14.7		24.0	2.1
LOS	B	A	B		C	A
Approach Delay		12.8	14.7		7.7	
Approach LOS		B	B		A	
90th %ile Green (s)	23.8	43.1	15.3		13.0	23.8
90th %ile Term Code	Gap	Hold	Gap		Max	Gap
70th %ile Green (s)	19.3	35.4	12.1		13.0	19.3
70th %ile Term Code	Gap	Hold	Gap		Max	Gap
50th %ile Green (s)	16.4	30.9	10.5		11.4	16.4
50th %ile Term Code	Gap	Hold	Gap		Gap	Gap
30th %ile Green (s)	13.7	26.6	8.9		9.5	13.7
30th %ile Term Code	Gap	Hold	Gap		Gap	Gap
10th %ile Green (s)	11.1	22.1	7.0		7.5	11.1
10th %ile Term Code	Gap	Hold	Gap		Gap	Gap

Intersection Summary

Area Type:	Other
Cycle Length:	90
Actuated Cycle Length:	50.5
Natural Cycle:	75
Control Type:	Actuated-Uncoordinated
Maximum v/c Ratio:	0.58
Intersection Signal Delay:	11.5
Intersection LOS:	B
Intersection Capacity Utilization:	49.9%
ICU Level of Service:	A

Lanes, Volumes, Timings  
 2: Shiloh Road & Hembree Ln

Existing Conditions  
 Timing Plan: P.M. Peak

Analysis Period (min) 15

90th %ile Actuated Cycle: 64.1

70th %ile Actuated Cycle: 56.4

50th %ile Actuated Cycle: 50.3

30th %ile Actuated Cycle: 44.1

10th %ile Actuated Cycle: 37.6

Splits and Phases: 2: Shiloh Road & Hembree Ln



Lanes, Volumes, Timings  
3: US 101 NB Off-Ramp & Shiloh Road

Existing Conditions  
Timing Plan: P.M. Peak

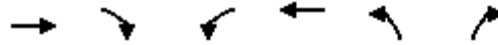

Lane Group	EBT	EBR	WBL	WBT	NBL	NBR
Lane Configurations	↑↑			↑	↘	↗↗
Traffic Volume (vph)	348	0	0	514	526	605
Future Volume (vph)	348	0	0	514	526	605
Ideal Flow (vphpl)	1900	1900	1900	1900	1900	1900
Storage Length (ft)		0	0		0	265
Storage Lanes		0	0		1	2
Taper Length (ft)			25		25	
Lane Util. Factor	0.95	1.00	1.00	1.00	1.00	0.88
Frt						0.850
Flt Protected					0.950	
Satd. Flow (prot)	3539	0	0	1863	1770	2787
Flt Permitted					0.950	
Satd. Flow (perm)	3539	0	0	1863	1770	2787
Right Turn on Red		Yes				Yes
Satd. Flow (RTOR)						672
Link Speed (mph)	40			40	30	
Link Distance (ft)	186			371	769	
Travel Time (s)	3.2			6.3	17.5	
Peak Hour Factor	0.94	0.94	0.97	0.97	0.90	0.90
Adj. Flow (vph)	370	0	0	530	584	672
Shared Lane Traffic (%)						
Lane Group Flow (vph)	370	0	0	530	584	672
Enter Blocked Intersection	No	No	No	No	No	No
Lane Alignment	Left	Right	Left	Left	Left	Right
Median Width(ft)	0			0	12	
Link Offset(ft)	0			0	0	
Crosswalk Width(ft)	16			16	16	
Two way Left Turn Lane						
Headway Factor	1.00	1.00	1.00	1.00	1.00	1.00
Turning Speed (mph)		9	15		15	9
Number of Detectors	2			2	1	1
Detector Template	Thru			Thru	Left	Right
Leading Detector (ft)	100			100	20	20
Trailing Detector (ft)	0			0	0	0
Detector 1 Position(ft)	0			0	0	0
Detector 1 Size(ft)	6			6	20	20
Detector 1 Type	Cl+Ex			Cl+Ex	Cl+Ex	Cl+Ex
Detector 1 Channel						
Detector 1 Extend (s)	0.0			0.0	0.0	0.0
Detector 1 Queue (s)	0.0			0.0	0.0	0.0
Detector 1 Delay (s)	0.0			0.0	0.0	0.0
Detector 2 Position(ft)	94			94		
Detector 2 Size(ft)	6			6		
Detector 2 Type	Cl+Ex			Cl+Ex		
Detector 2 Channel						
Detector 2 Extend (s)	0.0			0.0		
Turn Type	NA			NA	Prot	Perm
Protected Phases	2			6	8	
Permitted Phases						8

Lanes, Volumes, Timings  
 3: US 101 NB Off-Ramp & Shiloh Road

Existing Conditions  
 Timing Plan: P.M. Peak

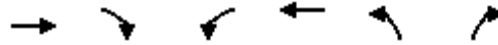

Lane Group	EBT	EBR	WBL	WBT	NBL	NBR
Detector Phase	2			6	8	8
Switch Phase						
Minimum Initial (s)	5.0			5.0	5.0	5.0
Minimum Split (s)	9.0			9.0	9.0	9.0
Total Split (s)	37.0			37.0	35.0	35.0
Total Split (%)	51.4%			51.4%	48.6%	48.6%
Maximum Green (s)	33.0			33.0	31.0	31.0
Yellow Time (s)	3.0			3.0	3.0	3.0
All-Red Time (s)	1.0			1.0	1.0	1.0
Lost Time Adjust (s)	0.0			0.0	0.0	0.0
Total Lost Time (s)	4.0			4.0	4.0	4.0
Lead/Lag						
Lead-Lag Optimize?						
Vehicle Extension (s)	3.0			3.0	3.0	3.0
Recall Mode	None			None	None	None
Act Effect Green (s)	21.6			21.6	23.9	23.9
Actuated g/C Ratio	0.40			0.40	0.44	0.44
v/c Ratio	0.26			0.71	0.75	0.42
Control Delay	11.9			20.5	21.4	2.1
Queue Delay	0.0			0.0	0.0	0.0
Total Delay	11.9			20.5	21.4	2.1
LOS	B			C	C	A
Approach Delay	11.9			20.5	11.0	
Approach LOS	B			C	B	
90th %ile Green (s)	33.0			33.0	31.0	31.0
90th %ile Term Code	Hold			Max	Max	Max
70th %ile Green (s)	26.9			26.9	31.0	31.0
70th %ile Term Code	Hold			Gap	Max	Max
50th %ile Green (s)	22.8			22.8	25.6	25.6
50th %ile Term Code	Hold			Gap	Gap	Gap
30th %ile Green (s)	16.6			16.6	19.3	19.3
30th %ile Term Code	Hold			Gap	Gap	Gap
10th %ile Green (s)	11.4			11.4	13.4	13.4
10th %ile Term Code	Hold			Gap	Gap	Gap

Intersection Summary

Area Type:	Other
Cycle Length:	72
Actuated Cycle Length:	54.2
Natural Cycle:	50
Control Type:	Actuated-Uncoordinated
Maximum v/c Ratio:	0.75
Intersection Signal Delay:	13.5
Intersection LOS:	B
Intersection Capacity Utilization:	95.1%
ICU Level of Service:	F
Analysis Period (min):	15
90th %ile Actuated Cycle:	72
70th %ile Actuated Cycle:	65.9
50th %ile Actuated Cycle:	56.4
30th %ile Actuated Cycle:	43.9

10th %ile Actuated Cycle: 32.8

Splits and Phases: 3: US 101 NB Off-Ramp & Shiloh Road

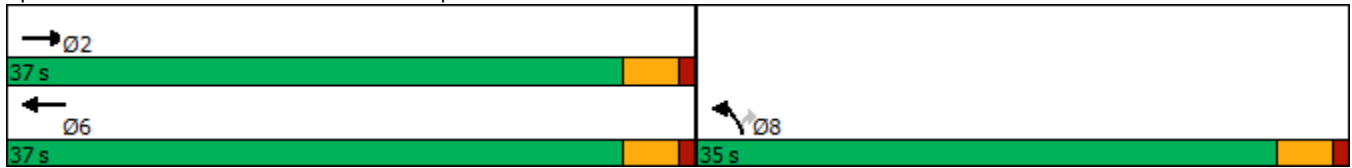

Lanes, Volumes, Timings  
4: Shiloh Road & US 101 SB Off-Ramp

Existing Conditions  
Timing Plan: P.M. Peak



Lane Group	EBL	EBT	WBT	WBR	SBL	SBR
Lane Configurations		↑	↑		↓	↓
Traffic Volume (vph)	0	423	615	0	121	110
Future Volume (vph)	0	423	615	0	121	110
Ideal Flow (vphpl)	1900	1900	1900	1900	1900	1900
Storage Length (ft)	0			0	0	275
Storage Lanes	0			0	1	1
Taper Length (ft)	25				25	
Lane Util. Factor	1.00	1.00	1.00	1.00	1.00	1.00
Ped Bike Factor						0.98
Frt						0.850
Flt Protected					0.950	
Satd. Flow (prot)	0	1863	1863	0	1770	1583
Flt Permitted					0.950	
Satd. Flow (perm)	0	1863	1863	0	1770	1548
Right Turn on Red				Yes		Yes
Satd. Flow (RTOR)						118
Link Speed (mph)		40	40		30	
Link Distance (ft)		225	306		486	
Travel Time (s)		3.8	5.2		11.0	
Confl. Peds. (#/hr)						1
Peak Hour Factor	0.89	0.89	0.96	0.96	0.93	0.93
Adj. Flow (vph)	0	475	641	0	130	118
Shared Lane Traffic (%)						
Lane Group Flow (vph)	0	475	641	0	130	118
Enter Blocked Intersection	No	No	No	No	No	No
Lane Alignment	Left	Left	Left	Right	Left	Right
Median Width(ft)		4	0		12	
Link Offset(ft)		0	0		0	
Crosswalk Width(ft)		16	16		16	
Two way Left Turn Lane						
Headway Factor	1.00	1.00	1.00	1.00	1.00	1.00
Turning Speed (mph)	15			9	15	9
Number of Detectors		2	2		1	1
Detector Template		Thru	Thru		Left	Right
Leading Detector (ft)		100	100		20	20
Trailing Detector (ft)		0	0		0	0
Detector 1 Position(ft)		0	0		0	0
Detector 1 Size(ft)		6	6		20	20
Detector 1 Type		Cl+Ex	Cl+Ex		Cl+Ex	Cl+Ex
Detector 1 Channel						
Detector 1 Extend (s)		0.0	0.0		0.0	0.0
Detector 1 Queue (s)		0.0	0.0		0.0	0.0
Detector 1 Delay (s)		0.0	0.0		0.0	0.0
Detector 2 Position(ft)		94	94			
Detector 2 Size(ft)		6	6			
Detector 2 Type		Cl+Ex	Cl+Ex			
Detector 2 Channel						
Detector 2 Extend (s)		0.0	0.0			
Turn Type		NA	NA		Perm	Perm

Lanes, Volumes, Timings  
4: Shiloh Road & US 101 SB Off-Ramp

Existing Conditions  
Timing Plan: P.M. Peak



Lane Group	EBL	EBT	WBT	WBR	SBL	SBR
Protected Phases		2	6			
Permitted Phases					4	4
Detector Phase		2	6		4	4
Switch Phase						
Minimum Initial (s)		5.0	5.0		5.0	5.0
Minimum Split (s)		9.0	38.0		9.0	9.0
Total Split (s)		69.0	69.0		21.0	21.0
Total Split (%)		76.7%	76.7%		23.3%	23.3%
Maximum Green (s)		65.0	65.0		17.0	17.0
Yellow Time (s)		3.0	3.0		3.0	3.0
All-Red Time (s)		1.0	1.0		1.0	1.0
Lost Time Adjust (s)		0.0	0.0		0.0	0.0
Total Lost Time (s)		4.0	4.0		4.0	4.0
Lead/Lag						
Lead-Lag Optimize?						
Vehicle Extension (s)		3.0	3.0		3.0	3.0
Recall Mode		None	None		None	None
Walk Time (s)			7.0			
Flash Dont Walk (s)			27.0			
Pedestrian Calls (#/hr)			0			
Act Effct Green (s)		21.5	21.5		8.9	8.9
Actuated g/C Ratio		0.64	0.64		0.27	0.27
v/c Ratio		0.40	0.54		0.28	0.24
Control Delay		5.9	7.4		15.2	5.4
Queue Delay		0.0	0.0		0.0	0.0
Total Delay		5.9	7.4		15.2	5.4
LOS		A	A		B	A
Approach Delay		5.9	7.4		10.5	
Approach LOS		A	A		B	
90th %ile Green (s)		29.7	29.7		11.3	11.3
90th %ile Term Code		Hold	Gap		Gap	Gap
70th %ile Green (s)		22.7	22.7		9.2	9.2
70th %ile Term Code		Hold	Gap		Gap	Gap
50th %ile Green (s)		17.9	17.9		7.9	7.9
50th %ile Term Code		Hold	Gap		Gap	Gap
30th %ile Green (s)		15.0	15.0		7.0	7.0
30th %ile Term Code		Hold	Gap		Gap	Gap
10th %ile Green (s)		10.8	10.8		0.0	0.0
10th %ile Term Code		Hold	Gap		Skip	Skip

Intersection Summary	
Area Type:	Other
Cycle Length:	90
Actuated Cycle Length:	33.5
Natural Cycle:	50
Control Type:	Actuated-Uncoordinated
Maximum v/c Ratio:	0.54
Intersection Signal Delay:	7.5
Intersection Capacity Utilization:	58.1%
Intersection LOS:	A
ICU Level of Service:	B

Lanes, Volumes, Timings  
 4: Shiloh Road & US 101 SB Off-Ramp

Existing Conditions  
 Timing Plan: P.M. Peak

Analysis Period (min) 15  
 90th %ile Actuated Cycle: 49  
 70th %ile Actuated Cycle: 39.9  
 50th %ile Actuated Cycle: 33.8  
 30th %ile Actuated Cycle: 30  
 10th %ile Actuated Cycle: 14.8

Splits and Phases: 4: Shiloh Road & US 101 SB Off-Ramp





Lanes, Volumes, Timings  
5: Caletti Ave & Shiloh Road

Existing Conditions  
Timing Plan: P.M. Peak





















Lane Group	EBT	EBR	WBL	WBT	NBL	NBR
Lane Configurations	↑↑		↵	↑	↵	↵
Traffic Volume (vph)	851	28	79	651	15	149
Future Volume (vph)	851	28	79	651	15	149
Ideal Flow (vphpl)	1900	1900	1900	1900	1900	1900
Storage Length (ft)		0	68		0	0
Storage Lanes		0	1		1	1
Taper Length (ft)			50		25	
Lane Util. Factor	0.95	0.95	1.00	1.00	1.00	1.00
Frt	0.995					0.850
Flt Protected			0.950		0.950	
Satd. Flow (prot)	3522	0	1770	1863	1770	1583
Flt Permitted			0.950		0.950	
Satd. Flow (perm)	3522	0	1770	1863	1770	1583
Link Speed (mph)	40			40	30	
Link Distance (ft)	1081			184	459	
Travel Time (s)	18.4			3.1	10.4	
Peak Hour Factor	0.89	0.89	0.92	0.92	0.89	0.89
Adj. Flow (vph)	956	31	86	708	17	167
Shared Lane Traffic (%)						
Lane Group Flow (vph)	987	0	86	708	17	167
Enter Blocked Intersection	No	No	No	No	No	No
Lane Alignment	Left	Right	Left	Left	Left	Right
Median Width(ft)	12			12	12	
Link Offset(ft)	0			0	0	
Crosswalk Width(ft)	16			16	16	
Two way Left Turn Lane						
Headway Factor	1.00	1.00	1.00	1.00	1.00	1.00
Turning Speed (mph)		9	15		15	9
Sign Control	Free			Free	Stop	

Intersection Summary

Area Type:	Other
Control Type:	Unsignalized
Intersection Capacity Utilization	44.3%
ICU Level of Service	A
Analysis Period (min)	15

Lanes, Volumes, Timings  
6: Conde Lane & Shiloh Road

Existing Conditions  
Timing Plan: P.M. Peak

												
Lane Group	EBL	EBT	EBR	WBL	WBT	WBR	NBL	NBT	NBR	SBL	SBT	SBR
Lane Configurations												
Traffic Volume (vph)	69	470	2	7	456	289	5	3	17	297	0	39
Future Volume (vph)	69	470	2	7	456	289	5	3	17	297	0	39
Ideal Flow (vphpl)	1900	1900	1900	1900	1900	1900	1900	1900	1900	1900	1900	1900
Storage Length (ft)	90		0	127		0	0		0	0		40
Storage Lanes	1		0	1		0	0		0	0		1
Taper Length (ft)	70			40			25			25		
Lane Util. Factor	1.00	0.95	0.95	1.00	0.95	0.95	1.00	1.00	1.00	1.00	1.00	1.00
Ped Bike Factor	1.00				0.99							
Frt		0.999			0.942			0.909				0.850
Flt Protected	0.950			0.950				0.990			0.950	
Satd. Flow (prot)	1770	3536	0	1770	3306	0	0	1676	0	0	1770	1583
Flt Permitted	0.950			0.950				0.990			0.950	
Satd. Flow (perm)	1767	3536	0	1770	3306	0	0	1676	0	0	1770	1583
Right Turn on Red			Yes			Yes			Yes			No
Satd. Flow (RTOR)					146			27				
Link Speed (mph)		40			40			30				35
Link Distance (ft)		815			1081			418				522
Travel Time (s)		13.9			18.4			9.5				10.2
Confl. Peds. (#/hr)	1						1					
Peak Hour Factor	0.88	0.88	0.88	0.80	0.80	0.80	0.63	0.63	0.63	0.88	0.88	0.88
Adj. Flow (vph)	78	534	2	9	570	361	8	5	27	338	0	44
Shared Lane Traffic (%)												
Lane Group Flow (vph)	78	536	0	9	931	0	0	40	0	0	338	44
Enter Blocked Intersection	No	No	No	No	No	No	No	No	No	No	No	No
Lane Alignment	Left	Left	Right	Left	Left	Right	Left	Left	Right	Left	Left	Right
Median Width(ft)		12			12			0				0
Link Offset(ft)		0			0			0				0
Crosswalk Width(ft)		16			16			16				16
Two way Left Turn Lane												
Headway Factor	1.00	1.00	1.00	1.00	1.00	1.00	1.00	1.00	1.00	1.00	1.00	1.00
Turning Speed (mph)	15		9	15		9	15		9	15		9
Number of Detectors	1	2		1	2		1	2		1	1	1
Detector Template	Left	Thru		Left	Thru		Left	Thru		Left	Thru	Right
Leading Detector (ft)	20	100		20	100		20	100		20	30	20
Trailing Detector (ft)	0	0		0	0		0	0		0	0	0
Detector 1 Position(ft)	0	0		0	0		0	0		0	0	0
Detector 1 Size(ft)	20	6		20	6		20	6		20	30	20
Detector 1 Type	Cl+Ex	Cl+Ex		Cl+Ex	Cl+Ex		Cl+Ex	Cl+Ex		Cl+Ex	Cl+Ex	Cl+Ex
Detector 1 Channel												
Detector 1 Extend (s)	0.0	0.0		0.0	0.0		0.0	0.0		0.0	0.0	0.0
Detector 1 Queue (s)	0.0	0.0		0.0	0.0		0.0	0.0		0.0	0.0	0.0
Detector 1 Delay (s)	0.0	0.0		0.0	0.0		0.0	0.0		0.0	0.0	0.0
Detector 2 Position(ft)		94			94			94				
Detector 2 Size(ft)		6			6			6				
Detector 2 Type		Cl+Ex			Cl+Ex			Cl+Ex				
Detector 2 Channel												
Detector 2 Extend (s)		0.0			0.0			0.0				
Turn Type	Prot	NA		Prot	NA		Split	NA		Split	NA	custom

Lanes, Volumes, Timings  
6: Conde Lane & Shiloh Road

Existing Conditions  
Timing Plan: P.M. Peak



Lane Group	EBL	EBT	EBR	WBL	WBT	WBR	NBL	NBT	NBR	SBL	SBT	SBR
Protected Phases	5	2		1	6		7	7		4	4	
Permitted Phases												6
Detector Phase	5	2		1	6		7	7		4	4	6
Switch Phase												
Minimum Initial (s)	8.0	8.0		8.0	8.0		10.0	10.0		11.0	11.0	8.0
Minimum Split (s)	12.0	46.0		12.0	12.0		37.0	37.0		15.0	15.0	12.0
Total Split (s)	13.0	46.0		12.0	45.0		37.0	37.0		15.0	15.0	45.0
Total Split (%)	11.8%	41.8%		10.9%	40.9%		33.6%	33.6%		13.6%	13.6%	40.9%
Maximum Green (s)	9.0	42.0		8.0	41.0		33.0	33.0		11.0	11.0	41.0
Yellow Time (s)	3.0	3.0		3.0	3.0		3.0	3.0		3.0	3.0	3.0
All-Red Time (s)	1.0	1.0		1.0	1.0		1.0	1.0		1.0	1.0	1.0
Lost Time Adjust (s)	0.0	0.0		0.0	0.0		0.0	0.0		0.0	0.0	0.0
Total Lost Time (s)	4.0	4.0		4.0	4.0		4.0	4.0		4.0	4.0	4.0
Lead/Lag	Lead	Lag		Lead	Lag							Lag
Lead-Lag Optimize?	Yes	Yes		Yes	Yes							Yes
Vehicle Extension (s)	3.0	3.0		3.0	3.0		3.0	3.0		3.0	3.0	3.0
Recall Mode	None	None		None	None		None	None		None	None	None
Walk Time (s)		7.0					7.0	7.0				
Flash Dont Walk (s)		35.0					26.0	26.0				
Pedestrian Calls (#/hr)		0					0	0				
Act Effct Green (s)	9.6	30.2		9.1	22.7			11.4			12.5	22.7
Actuated g/C Ratio	0.16	0.50		0.15	0.38			0.19			0.21	0.38
v/c Ratio	0.28	0.30		0.03	0.70			0.12			0.92	0.07
Control Delay	32.8	10.4		31.6	17.5			17.6			66.7	14.6
Queue Delay	0.0	0.0		0.0	0.0			0.0			0.0	0.0
Total Delay	32.8	10.4		31.6	17.5			17.6			66.7	14.6
LOS	C	B		C	B			B			E	B
Approach Delay		13.2			17.6			17.6			60.7	
Approach LOS		B			B			B			E	
90th %ile Green (s)	9.0	35.2		8.0	34.2		10.0	10.0		11.0	11.0	34.2
90th %ile Term Code	Max	Hold		Max	Gap		Min	Min		Max	Max	Gap
70th %ile Green (s)	9.0	41.1		0.0	28.1		10.0	10.0		11.0	11.0	28.1
70th %ile Term Code	Max	Hold		Skip	Gap		Min	Min		Max	Max	Gap
50th %ile Green (s)	8.8	37.3		0.0	24.5		10.0	10.0		11.0	11.0	24.5
50th %ile Term Code	Gap	Hold		Skip	Gap		Min	Min		Max	Max	Gap
30th %ile Green (s)	8.0	29.0		0.0	17.0		0.0	0.0		11.0	11.0	17.0
30th %ile Term Code	Min	Hold		Skip	Gap		Skip	Skip		Max	Max	Gap
10th %ile Green (s)	0.0	11.1		0.0	11.1		0.0	0.0		11.0	11.0	11.1
10th %ile Term Code	Skip	Hold		Skip	Gap		Skip	Skip		Max	Max	Gap

Intersection Summary

Area Type:	Other
Cycle Length:	110
Actuated Cycle Length:	60.5
Natural Cycle:	120
Control Type:	Actuated-Uncoordinated
Maximum v/c Ratio:	0.92
Intersection Signal Delay:	24.6
Intersection LOS:	C
Intersection Capacity Utilization:	61.7%
ICU Level of Service:	B

Lanes, Volumes, Timings  
 6: Conde Lane & Shiloh Road

Existing Conditions  
 Timing Plan: P.M. Peak





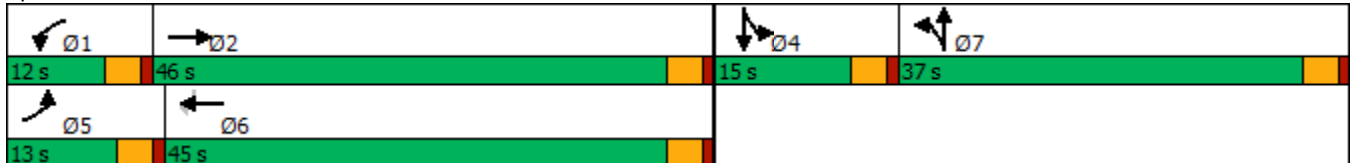











Analysis Period (min) 15  
 90th %ile Actuated Cycle: 80.2  
 70th %ile Actuated Cycle: 74.1  
 50th %ile Actuated Cycle: 70.3  
 30th %ile Actuated Cycle: 48  
 10th %ile Actuated Cycle: 30.1

Splits and Phases: 6: Conde Lane & Shiloh Road





















Lanes, Volumes, Timings  
7: Entrance 1/Gridley Drive & Shiloh Road

Existing Conditions  
Timing Plan: P.M. Peak

												
Lane Group	EBL	EBT	EBR	WBL	WBT	WBR	NBL	NBT	NBR	SBL	SBT	SBR
Lane Configurations												
Traffic Volume (vph)	17	103	0	0	125	0	0	0	0	0	0	14
Future Volume (vph)	17	103	0	0	125	0	0	0	0	0	0	14
Ideal Flow (vphpl)	1900	1900	1900	1900	1900	1900	1900	1900	1900	1900	1900	1900
Lane Util. Factor	1.00	1.00	1.00	1.00	1.00	1.00	1.00	1.00	1.00	1.00	1.00	1.00
Ped Bike Factor												
Frt												0.865
Flt Protected	0.993											
Satd. Flow (prot)	0	1850	0	0	1863	0	1863	1863	0	0	1611	0
Flt Permitted	0.993											
Satd. Flow (perm)	0	1850	0	0	1863	0	1863	1863	0	0	1611	0
Link Speed (mph)	40		40				30			30		
Link Distance (ft)	608		2146				248			715		
Travel Time (s)	10.4		36.6				5.6			16.3		
Confl. Peds. (#/hr)	1											
Confl. Bikes (#/hr)	1											
Peak Hour Factor	0.94	0.94	0.94	0.69	0.69	0.69	1.00	1.00	1.00	0.58	0.58	0.58
Adj. Flow (vph)	18	110	0	0	181	0	0	0	0	0	0	24
Shared Lane Traffic (%)												
Lane Group Flow (vph)	0	128	0	0	181	0	0	0	0	0	24	0
Enter Blocked Intersection	No	No	No	No	No	No	No	No	No	No	No	No
Lane Alignment	Left	Left	Right	Left	Left	Right	Left	Left	Right	Left	Left	Right
Median Width(ft)	0		0				12			12		
Link Offset(ft)	0		0				0			0		
Crosswalk Width(ft)	16		16				16			16		
Two way Left Turn Lane												
Headway Factor	1.00	1.00	1.00	1.00	1.00	1.00	1.00	1.00	1.00	1.00	1.00	1.00
Turning Speed (mph)	15		9		15		9		15		9	
Sign Control	Free		Free				Stop			Stop		
<b>Intersection Summary</b>												
Area Type:	Other											
Control Type:	Unsignalized											
Intersection Capacity Utilization	26.3%						ICU Level of Service A					
Analysis Period (min)	15											

Lanes, Volumes, Timings  
8: Old Redwood Hwy & Entrance 1

Existing Conditions  
Timing Plan: P.M. Peak

												
Lane Group	EBL	EBT	EBR	WBL	WBT	WBR	NBL	NBT	NBR	SBL	SBT	SBR
Lane Configurations												
Traffic Volume (vph)	3	0	0	0	0	0	0	505	0	0	427	0
Future Volume (vph)	3	0	0	0	0	0	0	505	0	0	427	0
Ideal Flow (vphpl)	1900	1900	1900	1900	1900	1900	1900	1900	1900	1900	1900	1900
Storage Length (ft)	0		0	0		0	0		0	50		0
Storage Lanes	0		0	1		0	0		0	1		0
Taper Length (ft)	25			25			25			25		
Lane Util. Factor	1.00	1.00	1.00	1.00	1.00	1.00	1.00	1.00	1.00	1.00	1.00	1.00
Ped Bike Factor												
Fr <sub>t</sub>												
Fl <sub>t</sub> Protected		0.950										
Satd. Flow (prot)	0	1770	0	1863	1863	0	0	1863	0	1863	1863	0
Fl <sub>t</sub> Permitted		0.950										
Satd. Flow (perm)	0	1770	0	1863	1863	0	0	1863	0	1863	1863	0
Link Speed (mph)		30			30			45			45	
Link Distance (ft)		98			385			520			748	
Travel Time (s)		2.2			8.8			7.9			11.3	
Confl. Bikes (#/hr)									3			5
Peak Hour Factor	0.38	0.38	0.38	1.00	1.00	1.00	0.91	0.91	0.91	0.94	0.94	0.94
Adj. Flow (vph)	8	0	0	0	0	0	0	555	0	0	454	0
Shared Lane Traffic (%)												
Lane Group Flow (vph)	0	8	0	0	0	0	0	555	0	0	454	0
Enter Blocked Intersection	No	No	No	No	No	No	No	No	No	No	No	No
Lane Alignment	Left	Left	Right	Left	Left	Right	Left	Left	Right	Left	Left	Right
Median Width(ft)		12			12			12			12	
Link Offset(ft)		0			0			0			0	
Crosswalk Width(ft)		16			16			16			16	
Two way Left Turn Lane												
Headway Factor	1.00	1.00	1.00	1.00	1.00	1.00	1.00	1.00	1.00	1.00	1.00	1.00
Turning Speed (mph)	15		9	15		9	15		9	15		9
Sign Control		Stop			Stop			Free			Free	
<b>Intersection Summary</b>												
Area Type:	Other											
Control Type:	Unsignalized											
Intersection Capacity Utilization	36.6%						ICU Level of Service A					
Analysis Period (min)	15											























Lanes, Volumes, Timings  
9: Entrance 2 & Shiloh Road

Existing Conditions  
Timing Plan: P.M. Peak

	→	↘	↙	←	↖	↗
Lane Group	EBT	EBR	WBL	WBT	NBL	NBR
Lane Configurations	↗			↖	↖	↗
Traffic Volume (vph)	81	0	0	111	0	0
Future Volume (vph)	81	0	0	111	0	0
Ideal Flow (vphpl)	1900	1900	1900	1900	1900	1900
Lane Util. Factor	1.00	1.00	1.00	1.00	1.00	1.00
<b>Fr</b>						
Flt Protected						
Satd. Flow (prot)	1863	0	0	1863	1863	1863
Flt Permitted						
Satd. Flow (perm)	1863	0	0	1863	1863	1863
Link Speed (mph)	40			40	30	
Link Distance (ft)	2146			134	402	
Travel Time (s)	36.6			2.3	9.1	
Peak Hour Factor	0.92	0.92	0.68	0.68	1.00	1.00
Adj. Flow (vph)	88	0	0	163	0	0
Shared Lane Traffic (%)						
Lane Group Flow (vph)	88	0	0	163	0	0
Enter Blocked Intersection	No	No	No	No	No	No
Lane Alignment	Left	Right	Left	Left	Left	Right
Median Width(ft)	0			0	12	
Link Offset(ft)	0			0	0	
Crosswalk Width(ft)	16			16	16	
Two way Left Turn Lane						
Headway Factor	1.00	1.00	1.00	1.00	1.00	1.00
Turning Speed (mph)		9	15		15	9
Sign Control	Free			Free	Stop	
<b>Intersection Summary</b>						
Area Type:	Other					
Control Type:	Unsignalized					
Intersection Capacity Utilization	9.2%			ICU Level of Service A		
Analysis Period (min)	15					

Lanes, Volumes, Timings  
 10: US 101 NB Off Ramp/Lakewood Drive & Old Redwood Highway

Existing Conditions  
 Timing Plan: P.M. Peak

												
Lane Group	EBL	EBT	EBR	WBL	WBT	WBR	NBL	NBT	NBR	SBL	SBT	SBR
Lane Configurations	 				 			 		 		
Traffic Volume (vph)	261	350	0	0	497	192	500	412	251	249	0	577
Future Volume (vph)	261	350	0	0	497	192	500	412	251	249	0	577
Ideal Flow (vphpl)	1900	1900	1900	1900	1900	1900	1900	1900	1900	1900	1900	1900
Storage Length (ft)	155		0	0		0	270		150	120		0
Storage Lanes	1		0	0		0	1		1	1		1
Taper Length (ft)	50			25			165			75		
Lane Util. Factor	0.97	1.00	1.00	1.00	0.95	0.95	0.91	0.91	0.95	0.97	1.00	1.00
Ped Bike Factor	1.00				0.99			0.99		1.00		
Fr <sub>t</sub>					0.958			0.951				0.850
Fl <sub>t</sub> Protected	0.950						0.950	0.993		0.950		
Satd. Flow (prot)	3433	1863	0	0	3370	0	1610	3181	0	3433	0	1583
Fl <sub>t</sub> Permitted	0.950						0.950	0.993		0.950		
Satd. Flow (perm)	3426	1863	0	0	3370	0	1610	3181	0	3420	0	1583
Right Turn on Red			Yes			Yes			Yes			Yes
Satd. Flow (RTOR)					65			85				300
Link Speed (mph)		35			35			30				30
Link Distance (ft)		226			617			716				478
Travel Time (s)		4.4			12.0			16.3				10.9
Confl. Peds. (#/hr)	3		1	1		3			8	8		
Confl. Bikes (#/hr)			2			9						
Peak Hour Factor	0.87	0.87	0.87	0.91	0.91	0.91	0.92	0.92	0.92	0.96	0.96	0.96
Adj. Flow (vph)	300	402	0	0	546	211	543	448	273	259	0	601
Shared Lane Traffic (%)							22%					
Lane Group Flow (vph)	300	402	0	0	757	0	424	840	0	259	0	601
Enter Blocked Intersection	No	No	No	No	No	No	No	No	No	No	No	No
Lane Alignment	Left	Left	Right	Left	Left	Right	Left	Left	Right	Left	Left	Right
Median Width(ft)		24			24			24				24
Link Offset(ft)		0			0			0				0
Crosswalk Width(ft)		16			16			16				16
Two way Left Turn Lane												
Headway Factor	1.00	1.00	1.00	1.00	1.00	1.00	1.00	1.00	1.00	1.00	1.00	1.00
Turning Speed (mph)	15		9	15		9	15		9	15		9
Number of Detectors	1	2			2		1	2		1		1
Detector Template	Left	Thru			Thru		Left	Thru		Left		Right
Leading Detector (ft)	20	100			100		20	100		20		20
Trailing Detector (ft)	0	0			0		0	0		0		0
Detector 1 Position(ft)	0	0			0		0	0		0		0
Detector 1 Size(ft)	20	6			6		20	6		20		20
Detector 1 Type	Cl+Ex	Cl+Ex			Cl+Ex		Cl+Ex	Cl+Ex		Cl+Ex		Cl+Ex
Detector 1 Channel												
Detector 1 Extend (s)	0.0	0.0			0.0		0.0	0.0		0.0		0.0
Detector 1 Queue (s)	0.0	0.0			0.0		0.0	0.0		0.0		0.0
Detector 1 Delay (s)	0.0	0.0			0.0		0.0	0.0		0.0		0.0
Detector 2 Position(ft)		94			94			94				
Detector 2 Size(ft)		6			6			6				
Detector 2 Type		Cl+Ex			Cl+Ex			Cl+Ex				
Detector 2 Channel												
Detector 2 Extend (s)		0.0			0.0			0.0				



Lanes, Volumes, Timings  
 10: US 101 NB Off Ramp/Lakewood Drive & Old Redwood Highway

Existing Conditions  
 Timing Plan: P.M. Peak



Lane Group	EBL	EBT	EBR	WBL	WBT	WBR	NBL	NBT	NBR	SBL	SBT	SBR
Turn Type	Prot	NA			NA		Split	NA		Prot		pm+ov
Protected Phases	5	2			6		8	8		7		5
Permitted Phases												5 8
Detector Phase	5	2			6		8	8		7		5
Switch Phase												
Minimum Initial (s)	7.0	10.0			10.0		10.0	10.0		7.0		7.0
Minimum Split (s)	11.0	32.1			32.1		33.7	33.7		11.0		11.0
Total Split (s)	13.0	45.3			32.3		33.7	33.7		11.0		13.0
Total Split (%)	14.4%	50.3%			35.9%		37.4%	37.4%		12.2%		14.4%
Maximum Green (s)	9.0	40.2			27.2		29.0	29.0		7.0		9.0
Yellow Time (s)	3.0	4.1			4.1		3.7	3.7		3.0		3.0
All-Red Time (s)	1.0	1.0			1.0		1.0	1.0		1.0		1.0
Lost Time Adjust (s)	0.0	0.0			0.0		0.0	0.0		0.0		0.0
Total Lost Time (s)	4.0	5.1			5.1		4.7	4.7		4.0		4.0
Lead/Lag	Lead				Lag		Lag	Lag		Lead		Lead
Lead-Lag Optimize?	Yes				Yes		Yes	Yes		Yes		Yes
Vehicle Extension (s)	3.0	3.0			3.0		3.0	3.0		3.0		3.0
Recall Mode	None	Max			Max		None	None		None		None
Walk Time (s)		7.0			7.0		7.0	7.0				
Flash Dont Walk (s)		20.0			17.0		22.0	22.0				
Pedestrian Calls (#/hr)		0			0		0	0				
Act Effct Green (s)	9.0	40.2			27.2		27.5	27.5		7.0		41.2
Actuated g/C Ratio	0.10	0.45			0.31		0.31	0.31		0.08		0.47
v/c Ratio	0.86	0.47			0.70		0.85	0.80		0.95		0.67
Control Delay	64.1	19.6			29.0		46.2	31.9		87.1		12.8
Queue Delay	0.0	0.0			0.0		0.0	0.0		0.0		0.0
Total Delay	64.1	19.6			29.0		46.2	31.9		87.1		12.8
LOS	E	B			C		D	C		F		B
Approach Delay		38.6			29.0			36.7				35.2
Approach LOS		D			C			D				D
90th %ile Green (s)	9.0	40.2			27.2		29.0	29.0		7.0		9.0
90th %ile Term Code	Max	MaxR			MaxR		Max	Max		Max		Max
70th %ile Green (s)	9.0	40.2			27.2		29.0	29.0		7.0		9.0
70th %ile Term Code	Max	MaxR			MaxR		Max	Max		Max		Max
50th %ile Green (s)	9.0	40.2			27.2		29.0	29.0		7.0		9.0
50th %ile Term Code	Max	MaxR			MaxR		Max	Max		Max		Max
30th %ile Green (s)	9.0	40.2			27.2		29.0	29.0		7.0		9.0
30th %ile Term Code	Max	MaxR			MaxR		Max	Max		Max		Max
10th %ile Green (s)	9.0	40.2			27.2		21.7	21.7		7.0		9.0
10th %ile Term Code	Max	MaxR			MaxR		Gap	Gap		Max		Max

Intersection Summary

Area Type:	Other
Cycle Length:	90
Actuated Cycle Length:	88.5
Natural Cycle:	90
Control Type:	Actuated-Uncoordinated
Maximum v/c Ratio:	0.95
Intersection Signal Delay:	35.1
Intersection LOS:	D

Lanes, Volumes, Timings  
 10: US 101 NB Off Ramp/Lakewood Drive & Old Redwood Highway

Existing Conditions  
 Timing Plan: P.M. Peak

Intersection Capacity Utilization 90.4%	ICU Level of Service E
Analysis Period (min) 15	
90th %ile Actuated Cycle: 90	
70th %ile Actuated Cycle: 90	
50th %ile Actuated Cycle: 90	
30th %ile Actuated Cycle: 90	
10th %ile Actuated Cycle: 82.7	

Splits and Phases: 10: US 101 NB Off Ramp/Lakewood Drive & Old Redwood Highway

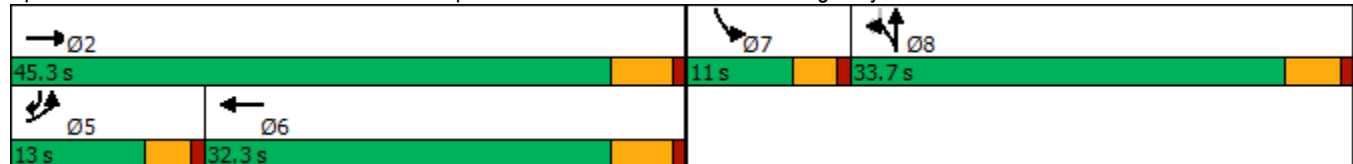

Lanes, Volumes, Timings  
 11: Old Redwood Highway & US 101 NB On Ramp

Existing Conditions  
 Timing Plan: P.M. Peak

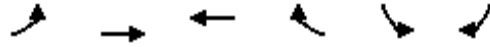

Lane Group	EBL	EBT	WBT	WBR	SBL	SBR
Lane Configurations						
Traffic Volume (vph)	106	605	1403	169	0	0
Future Volume (vph)	106	605	1403	169	0	0
Ideal Flow (vphpl)	1900	1900	1900	1900	1900	1900
Storage Length (ft)	245			0	0	0
Storage Lanes	1			0	0	0
Taper Length (ft)	50				25	
Lane Util. Factor	1.00	0.95	0.95	0.95	1.00	1.00
Ped Bike Factor						
Frt			0.984			
Flt Protected	0.950					
Satd. Flow (prot)	1770	3539	3483	0	0	0
Flt Permitted	0.950					
Satd. Flow (perm)	1770	3539	3483	0	0	0
Link Speed (mph)		35	35		30	
Link Distance (ft)		531	226		299	
Travel Time (s)		10.3	4.4		6.8	
Confl. Peds. (#/hr)	17			17		
Confl. Bikes (#/hr)				8		
Peak Hour Factor	0.85	0.85	0.91	0.91	0.25	0.25
Adj. Flow (vph)	125	712	1542	186	0	0
Shared Lane Traffic (%)						
Lane Group Flow (vph)	125	712	1728	0	0	0
Enter Blocked Intersection	No	No	No	No	No	No
Lane Alignment	Left	Left	Left	Right	Left	Right
Median Width(ft)		12	12		0	
Link Offset(ft)		0	0		0	
Crosswalk Width(ft)		16	16		16	
Two way Left Turn Lane						
Headway Factor	1.00	1.00	1.00	1.00	1.00	1.00
Turning Speed (mph)	15			9	15	9
Sign Control		Free	Free		Free	

Intersection Summary	
Area Type:	Other
Control Type:	Unsignalized
Intersection Capacity Utilization	65.0% ICU Level of Service C
Analysis Period (min)	15

Lanes, Volumes, Timings

Existing Conditions

12: US 101 SB On Ramp/US 101 SB Off Ramp & Old Redwood Highway

Timing Plan: P.M. Peak



Lane Group	EBL	EBT	EBR	WBL	WBT	WBR	NBL	NBT	NBR	SBL	SBT	SBR
Lane Configurations		↑↑	↗	↖	↑↑					↖	↕	
Traffic Volume (vph)	0	535	381	381	1024	0	0	0	0	167	0	129
Future Volume (vph)	0	535	381	381	1024	0	0	0	0	167	0	129
Ideal Flow (vphpl)	1900	1900	1900	1900	1900	1900	1900	1900	1900	1900	1900	1900
Storage Length (ft)	0		0	250		0	0		0	420		0
Storage Lanes	0		1	0		0	0		0	1		0
Taper Length (ft)	25			165			25			75		
Lane Util. Factor	1.00	0.95	1.00	1.00	0.95	1.00	1.00	1.00	1.00	0.95	0.95	1.00
Ped Bike Factor			0.98	1.00								
Frt			0.850								0.867	
Flt Protected				0.950						0.950	0.994	
Satd. Flow (prot)	0	3539	1583	1770	3539	0	0	0	0	1681	1525	0
Flt Permitted				0.950						0.950	0.994	
Satd. Flow (perm)	0	3539	1558	1768	3539	0	0	0	0	1681	1525	0
Right Turn on Red			Yes			Yes			Yes			Yes
Satd. Flow (RTOR)			405								121	
Link Speed (mph)		35			35			30			30	
Link Distance (ft)		423			531			621			831	
Travel Time (s)		8.2			10.3			14.1			18.9	
Confl. Peds. (#/hr)	19		2	2		18						
Confl. Bikes (#/hr)			4			2						
Peak Hour Factor	0.94	0.94	0.94	0.89	0.89	0.89	0.25	0.25	0.25	0.83	0.83	0.83
Adj. Flow (vph)	0	569	405	428	1151	0	0	0	0	201	0	155
Shared Lane Traffic (%)										10%		
Lane Group Flow (vph)	0	569	405	428	1151	0	0	0	0	181	175	0
Enter Blocked Intersection	No	No	No	No	No	No	No	No	No	No	No	No
Lane Alignment	Left	Left	Right	Left	Left	Right	Left	Left	Right	Left	Left	Right
Median Width(ft)		24			24			12			12	
Link Offset(ft)		0			0			0			0	
Crosswalk Width(ft)		16			16			16			16	
Two way Left Turn Lane												
Headway Factor	1.00	1.00	1.00	1.00	1.00	1.00	1.00	1.00	1.00	1.00	1.00	1.00
Turning Speed (mph)	15		9	15		9	15		9	15		9
Number of Detectors		2	1	1	2					1	2	
Detector Template		Thru	Right	Left	Thru					Left	Thru	
Leading Detector (ft)		100	20	20	100					20	100	
Trailing Detector (ft)		0	0	0	0					0	0	
Detector 1 Position(ft)		0	0	0	0					0	0	
Detector 1 Size(ft)		6	20	20	6					20	6	
Detector 1 Type		Cl+Ex	Cl+Ex	Cl+Ex	Cl+Ex					Cl+Ex	Cl+Ex	
Detector 1 Channel												
Detector 1 Extend (s)		0.0	0.0	0.0	0.0					0.0	0.0	
Detector 1 Queue (s)		0.0	0.0	0.0	0.0					0.0	0.0	
Detector 1 Delay (s)		0.0	0.0	0.0	0.0					0.0	0.0	
Detector 2 Position(ft)		94			94							94
Detector 2 Size(ft)		6			6							6
Detector 2 Type		Cl+Ex			Cl+Ex							Cl+Ex
Detector 2 Channel												
Detector 2 Extend (s)		0.0			0.0							0.0

Lanes, Volumes, Timings

Existing Conditions

12: US 101 SB On Ramp/US 101 SB Off Ramp & Old Redwood Highway

Timing Plan: P.M. Peak



Lane Group	EBL	EBT	EBR	WBL	WBT	WBR	NBL	NBT	NBR	SBL	SBT	SBR
Turn Type		NA	Perm	Prot	NA					Perm	NA	
Protected Phases		6		5	2						8	
Permitted Phases			6							8		
Detector Phase		6	6	5	2					8	8	
Switch Phase												
Minimum Initial (s)		10.0	10.0	7.0	10.0					10.0	10.0	
Minimum Split (s)		32.1	32.1	11.0	38.1					14.7	14.7	
Total Split (s)		33.0	33.0	22.0	55.0					15.0	15.0	
Total Split (%)		47.1%	47.1%	31.4%	78.6%					21.4%	21.4%	
Maximum Green (s)		27.9	27.9	18.0	49.9					10.3	10.3	
Yellow Time (s)		4.1	4.1	3.0	4.1					3.7	3.7	
All-Red Time (s)		1.0	1.0	1.0	1.0					1.0	1.0	
Lost Time Adjust (s)		0.0	0.0	0.0	0.0					0.0	0.0	
Total Lost Time (s)		5.1	5.1	4.0	5.1					4.7	4.7	
Lead/Lag		Lag	Lag	Lead								
Lead-Lag Optimize?		Yes	Yes	Yes								
Vehicle Extension (s)		3.0	3.0	3.0	3.0					3.0	3.0	
Recall Mode		Max	Max	None	Max					None	None	
Walk Time (s)		7.0	7.0		7.0							
Flash Dont Walk (s)		20.0	20.0		25.0							
Pedestrian Calls (#/hr)		0	0		0							
Act Effct Green (s)		27.9	27.9	18.0	49.9					10.2	10.2	
Actuated g/C Ratio		0.40	0.40	0.26	0.71					0.15	0.15	
v/c Ratio		0.40	0.47	0.94	0.46					0.74	0.54	
Control Delay		16.1	3.7	58.1	5.0					48.7	17.1	
Queue Delay		0.0	0.0	0.0	0.0					0.0	0.0	
Total Delay		16.1	3.7	58.1	5.0					48.7	17.1	
LOS		B	A	E	A					D	B	
Approach Delay		11.0			19.3						33.1	
Approach LOS		B			B						C	
90th %ile Green (s)		27.9	27.9	18.0	49.9					10.3	10.3	
90th %ile Term Code		MaxR	MaxR	Max	MaxR					Max	Max	
70th %ile Green (s)		27.9	27.9	18.0	49.9					10.3	10.3	
70th %ile Term Code		MaxR	MaxR	Max	MaxR					Max	Max	
50th %ile Green (s)		27.9	27.9	18.0	49.9					10.3	10.3	
50th %ile Term Code		MaxR	MaxR	Max	MaxR					Max	Max	
30th %ile Green (s)		27.9	27.9	18.0	49.9					10.3	10.3	
30th %ile Term Code		MaxR	MaxR	Max	MaxR					Max	Max	
10th %ile Green (s)		27.9	27.9	18.0	49.9					10.0	10.0	
10th %ile Term Code		MaxR	MaxR	Max	MaxR					Min	Min	

Intersection Summary

Area Type: Other

Cycle Length: 70

Actuated Cycle Length: 69.9

Natural Cycle: 70

Control Type: Actuated-Uncoordinated

Maximum v/c Ratio: 0.94

Intersection Signal Delay: 18.2

Intersection LOS: B

Lanes, Volumes, Timings

Existing Conditions

12: US 101 SB On Ramp/US 101 SB Off Ramp & Old Redwood Highway

Timing Plan: P.M. Peak

Intersection Capacity Utilization 65.0% ICU Level of Service C

Analysis Period (min) 15

90th %ile Actuated Cycle: 70

70th %ile Actuated Cycle: 70

50th %ile Actuated Cycle: 70

30th %ile Actuated Cycle: 70





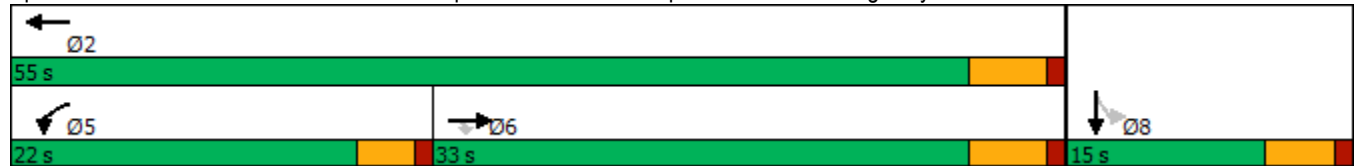

















10th %ile Actuated Cycle: 69.7

Splits and Phases: 12: US 101 SB On Ramp/US 101 SB Off Ramp & Old Redwood Highway



Lanes, Volumes, Timings  
1: Old Redwood Hwy & Shiloh Road

Existing Conditions  
Timing Plan: Saturday Midday Peak

												
Lane Group	EBL	EBT	EBR	WBL	WBT	WBR	NBL	NBT	NBR	SBL	SBT	SBR
Lane Configurations												
Traffic Volume (vph)	123	71	146	21	71	15	150	229	24	20	184	180
Future Volume (vph)	123	71	146	21	71	15	150	229	24	20	184	180
Ideal Flow (vphpl)	1900	1900	1900	1900	1900	1900	1900	1900	1900	1900	1900	1900
Storage Length (ft)	375		140	0		50	200		98	130		93
Storage Lanes	1		1	0		1	1		1	1		1
Taper Length (ft)	50			25			60			93		
Lane Util. Factor	1.00	1.00	1.00	1.00	1.00	1.00	1.00	1.00	1.00	1.00	1.00	1.00
Ped Bike Factor	0.99		0.98						0.98			0.97
Fr <sub>t</sub>			0.850			0.850			0.850			0.850
Fl <sub>t</sub> Protected	0.950				0.989		0.950			0.950		
Satd. Flow (prot)	1770	1863	1583	0	1842	1583	1770	1863	1583	1770	1863	1583
Fl <sub>t</sub> Permitted	0.950				0.989		0.950			0.950		
Satd. Flow (perm)	1759	1863	1549	0	1842	1583	1770	1863	1550	1770	1863	1540
Right Turn on Red			Yes			Yes			Yes			Yes
Satd. Flow (RTOR)			164			105			77			167
Link Speed (mph)		40			40			45			40	
Link Distance (ft)		1789			608			748			775	
Travel Time (s)		30.5			10.4			11.3			13.2	
Confl. Peds. (#/hr)	4											
Confl. Bikes (#/hr)			1						1			5
Peak Hour Factor	0.89	0.89	0.89	0.86	0.86	0.86	0.93	0.93	0.93	0.91	0.91	0.91
Adj. Flow (vph)	138	80	164	24	83	17	161	246	26	22	202	198
Shared Lane Traffic (%)												
Lane Group Flow (vph)	138	80	164	0	107	17	161	246	26	22	202	198
Enter Blocked Intersection	No	No	No	No	No	No	No	No	No	No	No	No
Lane Alignment	Left	Left	Right	Left	Left	Right	Left	Left	Right	Left	Left	Right
Median Width(ft)		12			12			12			12	
Link Offset(ft)		0			0			0			0	
Crosswalk Width(ft)		16			16			16			16	
Two way Left Turn Lane												
Headway Factor	1.00	1.00	1.00	1.00	1.00	1.00	1.00	1.00	1.00	1.00	1.00	1.00
Turning Speed (mph)	15		9	15		9	15		9	15		9
Number of Detectors	1	2	1	1	2	1	1	2	1	1	2	1
Detector Template	Left	Thru	Right	Left	Thru	Right	Left	Thru	Right	Left	Thru	Right
Leading Detector (ft)	20	100	20	20	100	20	20	100	20	20	100	20
Trailing Detector (ft)	0	0	0	0	0	0	0	0	0	0	0	0
Detector 1 Position(ft)	0	0	0	0	0	0	0	0	0	0	0	0
Detector 1 Size(ft)	20	6	20	20	6	20	20	6	20	20	6	20
Detector 1 Type	Cl+Ex	Cl+Ex	Cl+Ex	Cl+Ex	Cl+Ex	Cl+Ex	Cl+Ex	Cl+Ex	Cl+Ex	Cl+Ex	Cl+Ex	Cl+Ex
Detector 1 Channel												
Detector 1 Extend (s)	0.0	0.0	0.0	0.0	0.0	0.0	0.0	0.0	0.0	0.0	0.0	0.0
Detector 1 Queue (s)	0.0	0.0	0.0	0.0	0.0	0.0	0.0	0.0	0.0	0.0	0.0	0.0
Detector 1 Delay (s)	0.0	0.0	0.0	0.0	0.0	0.0	0.0	0.0	0.0	0.0	0.0	0.0
Detector 2 Position(ft)		94			94			94			94	
Detector 2 Size(ft)		6			6			6			6	
Detector 2 Type		Cl+Ex			Cl+Ex			Cl+Ex			Cl+Ex	
Detector 2 Channel												
Detector 2 Extend (s)		0.0			0.0			0.0			0.0	

Lanes, Volumes, Timings  
1: Old Redwood Hwy & Shiloh Road

Existing Conditions  
Timing Plan: Saturday Midday Peak



Lane Group	EBL	EBT	EBR	WBL	WBT	WBR	NBL	NBT	NBR	SBL	SBT	SBR
Turn Type	Split	NA	Perm	Split	NA	Perm	Prot	NA	Perm	Prot	NA	Perm
Protected Phases	2	2		6	6		3	8		7	4	
Permitted Phases			2			6			8			4
Detector Phase	2	2	2	6	6	6	3	8	8	7	4	4
Switch Phase												
Minimum Initial (s)	5.0	5.0	5.0	5.0	5.0	5.0	5.0	5.0	5.0	5.0	5.0	5.0
Minimum Split (s)	34.5	34.5	34.5	42.5	42.5	42.5	8.5	46.5	46.5	8.5	39.5	39.5
Total Split (s)	35.0	35.0	35.0	42.5	42.5	42.5	18.0	48.0	48.0	9.5	39.5	39.5
Total Split (%)	25.9%	25.9%	25.9%	31.5%	31.5%	31.5%	13.3%	35.6%	35.6%	7.0%	29.3%	29.3%
Maximum Green (s)	30.5	30.5	30.5	38.0	38.0	38.0	14.5	43.5	43.5	6.0	35.0	35.0
Yellow Time (s)	3.5	3.5	3.5	3.5	3.5	3.5	3.0	3.5	3.5	3.0	3.5	3.5
All-Red Time (s)	1.0	1.0	1.0	1.0	1.0	1.0	0.5	1.0	1.0	0.5	1.0	1.0
Lost Time Adjust (s)	0.0	0.0	0.0		0.0	0.0	0.0	0.0	0.0	0.0	0.0	0.0
Total Lost Time (s)	4.5	4.5	4.5		4.5	4.5	3.5	4.5	4.5	3.5	4.5	4.5
Lead/Lag	Lead	Lead	Lead	Lag	Lag	Lag	Lead	Lag	Lag	Lead	Lag	Lag
Lead-Lag Optimize?	Yes	Yes	Yes	Yes	Yes	Yes	Yes	Yes	Yes	Yes	Yes	Yes
Vehicle Extension (s)	3.0	3.0	3.0	3.0	3.0	3.0	3.0	3.0	3.0	3.0	3.0	3.0
Recall Mode	None	None	None	None	None	None	None	None	None	None	None	None
Walk Time (s)	7.0	7.0	7.0	7.0	7.0	7.0		7.0	7.0		7.0	7.0
Flash Dont Walk (s)	23.0	23.0	23.0	31.0	31.0	31.0		35.0	35.0		28.0	28.0
Pedestrian Calls (#/hr)	0	0	0	0	0	0		0	0		0	0
Act Effct Green (s)	11.3	11.3	11.3		9.9	9.9	12.9	26.9	26.9	6.2	13.3	13.3
Actuated g/C Ratio	0.18	0.18	0.18		0.16	0.16	0.21	0.43	0.43	0.10	0.21	0.21
v/c Ratio	0.43	0.24	0.39		0.37	0.05	0.44	0.30	0.04	0.12	0.51	0.43
Control Delay	30.5	27.0	8.3		31.1	0.3	29.9	16.9	0.1	34.0	29.2	10.0
Queue Delay	0.0	0.0	0.0		0.0	0.0	0.0	0.0	0.0	0.0	0.0	0.0
Total Delay	30.5	27.0	8.3		31.1	0.3	29.9	16.9	0.1	34.0	29.2	10.0
LOS	C	C	A		C	A	C	B	A	C	C	A
Approach Delay		20.2			26.8			20.7			20.4	
Approach LOS		C			C			C			C	
90th %ile Green (s)	17.0	17.0	17.0	14.0	14.0	14.0	14.5	28.4	28.4	6.0	19.9	19.9
90th %ile Term Code	Gap	Gap	Gap	Gap	Gap	Gap	Max	Hold	Hold	Max	Gap	Gap
70th %ile Green (s)	12.7	12.7	12.7	11.1	11.1	11.1	14.5	23.5	23.5	6.0	15.0	15.0
70th %ile Term Code	Gap	Gap	Gap	Gap	Gap	Gap	Max	Hold	Hold	Max	Gap	Gap
50th %ile Green (s)	10.8	10.8	10.8	9.5	9.5	9.5	13.5	29.8	29.8	0.0	12.8	12.8
50th %ile Term Code	Gap	Gap	Gap	Gap	Gap	Gap	Gap	Hold	Hold	Skip	Gap	Gap
30th %ile Green (s)	9.2	9.2	9.2	8.2	8.2	8.2	11.5	25.8	25.8	0.0	10.8	10.8
30th %ile Term Code	Gap	Gap	Gap	Gap	Gap	Gap	Gap	Hold	Hold	Skip	Gap	Gap
10th %ile Green (s)	7.3	7.3	7.3	0.0	0.0	0.0	9.2	21.2	21.2	0.0	8.5	8.5
10th %ile Term Code	Gap	Gap	Gap	Skip	Skip	Skip	Gap	Hold	Hold	Skip	Gap	Gap

Intersection Summary

Area Type: Other  
 Cycle Length: 135  
 Actuated Cycle Length: 62.1  
 Natural Cycle: 135  
 Control Type: Actuated-Uncoordinated  
 Maximum v/c Ratio: 0.51  
 Intersection Signal Delay: 21.0  
 Intersection LOS: C



Lanes, Volumes, Timings  
 1: Old Redwood Hwy & Shiloh Road

Existing Conditions  
 Timing Plan: Saturday Midday Peak

Intersection Capacity Utilization 42.3%	ICU Level of Service A
Analysis Period (min) 15	
90th %ile Actuated Cycle: 82.4	
70th %ile Actuated Cycle: 70.3	
50th %ile Actuated Cycle: 63.6	
30th %ile Actuated Cycle: 56.7	
10th %ile Actuated Cycle: 37.5	

Splits and Phases: 1: Old Redwood Hwy & Shiloh Road

 Ø2	 Ø6	 Ø3	 Ø4
35 s	42.5 s	18 s	39.5 s
		 Ø7	 Ø8
		9.5 s	48 s

Lanes, Volumes, Timings  
2: Shiloh Road & Hembree Ln

Existing Conditions  
Timing Plan: Saturday Midday Peak



Lane Group	EBL	EBT	WBT	WBR	SBL	SBR
Lane Configurations	↙↘	↑	↕↘		↙	↘
Traffic Volume (vph)	622	252	202	159	160	580
Future Volume (vph)	622	252	202	159	160	580
Ideal Flow (vphpl)	1900	1900	1900	1900	1900	1900
Storage Length (ft)	0			130	0	0
Storage Lanes	2			1	1	1
Taper Length (ft)	25				25	
Lane Util. Factor	0.97	1.00	0.95	0.95	1.00	1.00
Ped Bike Factor	1.00		0.99			
Frt			0.934			0.850
Flt Protected	0.950				0.950	
Satd. Flow (prot)	3433	1863	3287	0	1770	1583
Flt Permitted	0.950				0.950	
Satd. Flow (perm)	3431	1863	3287	0	1770	1583
Right Turn on Red				Yes		Yes
Satd. Flow (RTOR)			166			592
Link Speed (mph)		40	40		35	
Link Distance (ft)		302	1789		381	
Travel Time (s)		5.1	30.5		7.4	
Confl. Peds. (#/hr)	1			1		
Peak Hour Factor	0.94	0.94	0.96	0.96	0.91	0.91
Adj. Flow (vph)	662	268	210	166	176	637
Shared Lane Traffic (%)						
Lane Group Flow (vph)	662	268	376	0	176	637
Enter Blocked Intersection	No	No	No	No	No	No
Lane Alignment	Left	Left	Left	Right	Left	Right
Median Width(ft)		24	24		12	
Link Offset(ft)		0	0		0	
Crosswalk Width(ft)		16	16		16	
Two way Left Turn Lane						
Headway Factor	1.00	1.00	1.00	1.00	1.00	1.00
Turning Speed (mph)	15			9	15	9
Number of Detectors	1	2	2		1	1
Detector Template	Left	Thru	Thru		Left	Right
Leading Detector (ft)	20	100	100		20	20
Trailing Detector (ft)	0	0	0		0	0
Detector 1 Position(ft)	0	0	0		0	0
Detector 1 Size(ft)	20	6	6		20	20
Detector 1 Type	Cl+Ex	Cl+Ex	Cl+Ex		Cl+Ex	Cl+Ex
Detector 1 Channel						
Detector 1 Extend (s)	0.0	0.0	0.0		0.0	0.0
Detector 1 Queue (s)	0.0	0.0	0.0		0.0	0.0
Detector 1 Delay (s)	0.0	0.0	0.0		0.0	0.0
Detector 2 Position(ft)		94	94			
Detector 2 Size(ft)		6	6			
Detector 2 Type		Cl+Ex	Cl+Ex			
Detector 2 Channel						
Detector 2 Extend (s)		0.0	0.0			
Turn Type	Prot	NA	NA		Perm	pm+ov

Lanes, Volumes, Timings  
2: Shiloh Road & Hembree Ln

Existing Conditions  
Timing Plan: Saturday Midday Peak



Lane Group	EBL	EBT	WBT	WBR	SBL	SBR
Protected Phases	5	2	6			5
Permitted Phases					4	4 5
Detector Phase	5	2	6		4	5
Switch Phase						
Minimum Initial (s)	3.0	5.0	5.0		5.0	3.0
Minimum Split (s)	7.0	9.0	43.0		9.0	7.0
Total Split (s)	29.0	73.0	44.0		17.0	29.0
Total Split (%)	32.2%	81.1%	48.9%		18.9%	32.2%
Maximum Green (s)	25.0	69.0	40.0		13.0	25.0
Yellow Time (s)	3.0	3.0	3.0		3.0	3.0
All-Red Time (s)	1.0	1.0	1.0		1.0	1.0
Lost Time Adjust (s)	0.0	0.0	0.0		0.0	0.0
Total Lost Time (s)	4.0	4.0	4.0		4.0	4.0
Lead/Lag	Lead		Lag			Lead
Lead-Lag Optimize?	Yes		Yes			Yes
Vehicle Extension (s)	3.0	3.0	3.0		3.0	3.0
Recall Mode	None	None	None		None	None
Walk Time (s)			7.0			
Flash Dont Walk (s)			32.0			
Pedestrian Calls (#/hr)			0			
Act Effct Green (s)	17.2	30.6	9.3		10.7	32.0
Actuated g/C Ratio	0.35	0.62	0.19		0.22	0.65
v/c Ratio	0.56	0.23	0.50		0.46	0.52
Control Delay	15.6	4.9	13.5		23.3	2.3
Queue Delay	0.0	0.0	0.0		0.0	0.0
Total Delay	15.6	4.9	13.5		23.3	2.3
LOS	B	A	B		C	A
Approach Delay		12.5	13.5		6.8	
Approach LOS		B	B		A	
90th %ile Green (s)	24.4	41.8	13.4		13.0	24.4
90th %ile Term Code	Gap	Hold	Gap		Max	Gap
70th %ile Green (s)	20.0	34.5	10.5		13.0	20.0
70th %ile Term Code	Gap	Hold	Gap		Max	Gap
50th %ile Green (s)	17.2	30.4	9.2		11.2	17.2
50th %ile Term Code	Gap	Hold	Gap		Gap	Gap
30th %ile Green (s)	14.5	26.3	7.8		9.4	14.5
30th %ile Term Code	Gap	Hold	Gap		Gap	Gap
10th %ile Green (s)	11.0	21.1	6.1		7.3	11.0
10th %ile Term Code	Gap	Hold	Gap		Gap	Gap

Intersection Summary

Area Type:	Other
Cycle Length:	90
Actuated Cycle Length:	49.6
Natural Cycle:	75
Control Type:	Actuated-Uncoordinated
Maximum v/c Ratio:	0.56
Intersection Signal Delay:	10.5
Intersection LOS:	B
Intersection Capacity Utilization:	54.0%
ICU Level of Service:	A

Lanes, Volumes, Timings  
 2: Shiloh Road & Hembree Ln

Existing Conditions  
 Timing Plan: Saturday Midday Peak

Analysis Period (min) 15

90th %ile Actuated Cycle: 62.8

70th %ile Actuated Cycle: 55.5

50th %ile Actuated Cycle: 49.6

30th %ile Actuated Cycle: 43.7

10th %ile Actuated Cycle: 36.4

Splits and Phases: 2: Shiloh Road & Hembree Ln



Lanes, Volumes, Timings  
3: US 101 NB Off-Ramp & Shiloh Road

Existing Conditions  
Timing Plan: Saturday Midday Peak



Lane Group	EBT	EBR	WBL	WBT	NBL	NBR
Lane Configurations	↑↑			↑	↘	↗
Traffic Volume (vph)	354	0	0	610	352	518
Future Volume (vph)	354	0	0	610	352	518
Ideal Flow (vphpl)	1900	1900	1900	1900	1900	1900
Storage Length (ft)		0	0		0	265
Storage Lanes		0	0		1	2
Taper Length (ft)			25		25	
Lane Util. Factor	0.95	1.00	1.00	1.00	1.00	0.88
Ped Bike Factor						
Frt						0.850
Flt Protected					0.950	
Satd. Flow (prot)	3539	0	0	1863	1770	2787
Flt Permitted					0.950	
Satd. Flow (perm)	3539	0	0	1863	1770	2787
Right Turn on Red		Yes				Yes
Satd. Flow (RTOR)						545
Link Speed (mph)	40			40	30	
Link Distance (ft)	186			371	769	
Travel Time (s)	3.2			6.3	17.5	
Confl. Bikes (#/hr)		1				
Peak Hour Factor	0.91	0.91	0.89	0.89	0.95	0.95
Adj. Flow (vph)	389	0	0	685	371	545
Shared Lane Traffic (%)						
Lane Group Flow (vph)	389	0	0	685	371	545
Enter Blocked Intersection	No	No	No	No	No	No
Lane Alignment	Left	Right	Left	Left	Left	Right
Median Width(ft)	0			0	12	
Link Offset(ft)	0			0	0	
Crosswalk Width(ft)	16			16	16	
Two way Left Turn Lane						
Headway Factor	1.00	1.00	1.00	1.00	1.00	1.00
Turning Speed (mph)		9	15		15	9
Number of Detectors	2			2	1	1
Detector Template	Thru			Thru	Left	Right
Leading Detector (ft)	100			100	20	20
Trailing Detector (ft)	0			0	0	0
Detector 1 Position(ft)	0			0	0	0
Detector 1 Size(ft)	6			6	20	20
Detector 1 Type	Cl+Ex			Cl+Ex	Cl+Ex	Cl+Ex
Detector 1 Channel						
Detector 1 Extend (s)	0.0			0.0	0.0	0.0
Detector 1 Queue (s)	0.0			0.0	0.0	0.0
Detector 1 Delay (s)	0.0			0.0	0.0	0.0
Detector 2 Position(ft)	94			94		
Detector 2 Size(ft)	6			6		
Detector 2 Type	Cl+Ex			Cl+Ex		
Detector 2 Channel						
Detector 2 Extend (s)	0.0			0.0		
Turn Type	NA			NA	Prot	Perm

Lanes, Volumes, Timings  
3: US 101 NB Off-Ramp & Shiloh Road

Existing Conditions  
Timing Plan: Saturday Midday Peak



Lane Group	EBT	EBR	WBL	WBT	NBL	NBR
Protected Phases	2			6	8	
Permitted Phases						8
Detector Phase	2			6	8	8
Switch Phase						
Minimum Initial (s)	5.0			5.0	5.0	5.0
Minimum Split (s)	9.0			9.0	9.0	9.0
Total Split (s)	37.0			37.0	35.0	35.0
Total Split (%)	51.4%			51.4%	48.6%	48.6%
Maximum Green (s)	33.0			33.0	31.0	31.0
Yellow Time (s)	3.0			3.0	3.0	3.0
All-Red Time (s)	1.0			1.0	1.0	1.0
Lost Time Adjust (s)	0.0			0.0	0.0	0.0
Total Lost Time (s)	4.0			4.0	4.0	4.0
Lead/Lag						
Lead-Lag Optimize?						
Vehicle Extension (s)	3.0			3.0	3.0	3.0
Recall Mode	None			None	None	None
Act Effct Green (s)	24.0			24.0	17.7	17.7
Actuated g/C Ratio	0.48			0.48	0.35	0.35
v/c Ratio	0.23			0.77	0.60	0.41
Control Delay	8.8			19.1	19.0	2.5
Queue Delay	0.0			0.0	0.0	0.0
Total Delay	8.8			19.1	19.0	2.5
LOS	A			B	B	A
Approach Delay	8.8			19.1	9.2	
Approach LOS	A			B	A	
90th %ile Green (s)	33.0			33.0	27.9	27.9
90th %ile Term Code	Hold			Max	Gap	Gap
70th %ile Green (s)	32.1			32.1	22.0	22.0
70th %ile Term Code	Hold			Gap	Gap	Gap
50th %ile Green (s)	24.1			24.1	17.6	17.6
50th %ile Term Code	Hold			Gap	Gap	Gap
30th %ile Green (s)	19.3			19.3	14.0	14.0
30th %ile Term Code	Hold			Gap	Gap	Gap
10th %ile Green (s)	13.1			13.1	9.2	9.2
10th %ile Term Code	Hold			Gap	Gap	Gap

Intersection Summary

Area Type:	Other
Cycle Length:	72
Actuated Cycle Length:	50.5
Natural Cycle:	45
Control Type:	Actuated-Uncoordinated
Maximum v/c Ratio:	0.77
Intersection Signal Delay:	12.5
Intersection LOS:	B
Intersection Capacity Utilization:	84.7%
ICU Level of Service:	E
Analysis Period (min):	15
90th %ile Actuated Cycle:	68.9
70th %ile Actuated Cycle:	62.1

Lanes, Volumes, Timings  
3: US 101 NB Off-Ramp & Shiloh Road

Existing Conditions  
Timing Plan: Saturday Midday Peak

50th %ile Actuated Cycle: 49.7  
30th %ile Actuated Cycle: 41.3  
10th %ile Actuated Cycle: 30.3

Splits and Phases: 3: US 101 NB Off-Ramp & Shiloh Road

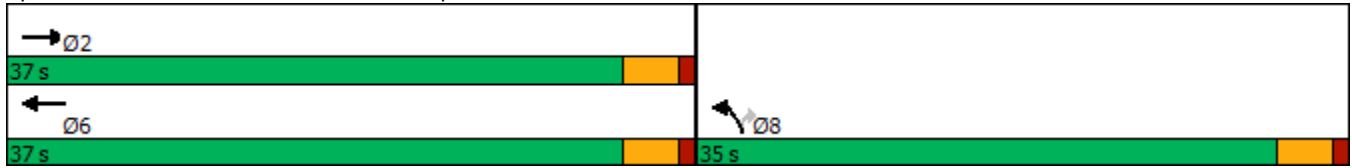

Lanes, Volumes, Timings  
4: Shiloh Road & US 101 SB Off-Ramp

Existing Conditions  
Timing Plan: Saturday Midday Peak



Lane Group	EBL	EBT	WBT	WBR	SBL	SBR
Lane Configurations		↑	↑		↓	↓
Traffic Volume (vph)	0	265	515	0	168	151
Future Volume (vph)	0	265	515	0	168	151
Ideal Flow (vphp)	1900	1900	1900	1900	1900	1900
Storage Length (ft)	0			0	0	275
Storage Lanes	0			0	1	1
Taper Length (ft)	25				25	
Lane Util. Factor	1.00	1.00	1.00	1.00	1.00	1.00
Ped Bike Factor						
Frt						0.850
Flt Protected					0.950	
Satd. Flow (prot)	0	1863	1863	0	1770	1583
Flt Permitted					0.950	
Satd. Flow (perm)	0	1863	1863	0	1770	1583
Right Turn on Red				Yes		Yes
Satd. Flow (RTOR)						222
Link Speed (mph)		40	40		30	
Link Distance (ft)		225	306		486	
Travel Time (s)		3.8	5.2		11.0	
Confl. Bikes (#/hr)				2		
Peak Hour Factor	0.96	0.96	0.96	0.96	0.68	0.68
Adj. Flow (vph)	0	276	536	0	247	222
Shared Lane Traffic (%)						
Lane Group Flow (vph)	0	276	536	0	247	222
Enter Blocked Intersection	No	No	No	No	No	No
Lane Alignment	Left	Left	Left	Right	Left	Right
Median Width(ft)		4	0		12	
Link Offset(ft)		0	0		0	
Crosswalk Width(ft)		16	16		16	
Two way Left Turn Lane						
Headway Factor	1.00	1.00	1.00	1.00	1.00	1.00
Turning Speed (mph)	15			9	15	9
Number of Detectors		2	2		1	1
Detector Template		Thru	Thru		Left	Right
Leading Detector (ft)		100	100		20	20
Trailing Detector (ft)		0	0		0	0
Detector 1 Position(ft)		0	0		0	0
Detector 1 Size(ft)		6	6		20	20
Detector 1 Type		Cl+Ex	Cl+Ex		Cl+Ex	Cl+Ex
Detector 1 Channel						
Detector 1 Extend (s)		0.0	0.0		0.0	0.0
Detector 1 Queue (s)		0.0	0.0		0.0	0.0
Detector 1 Delay (s)		0.0	0.0		0.0	0.0
Detector 2 Position(ft)		94	94			
Detector 2 Size(ft)		6	6			
Detector 2 Type		Cl+Ex	Cl+Ex			
Detector 2 Channel						
Detector 2 Extend (s)		0.0	0.0			
Turn Type		NA	NA		Perm	Perm



Lanes, Volumes, Timings  
4: Shiloh Road & US 101 SB Off-Ramp

Existing Conditions  
Timing Plan: Saturday Midday Peak



Lane Group	EBL	EBT	WBT	WBR	SBL	SBR
Protected Phases		2	6			
Permitted Phases					4	4
Detector Phase		2	6		4	4
Switch Phase						
Minimum Initial (s)		5.0	5.0		5.0	5.0
Minimum Split (s)		9.0	38.0		9.0	9.0
Total Split (s)		69.0	69.0		21.0	21.0
Total Split (%)		76.7%	76.7%		23.3%	23.3%
Maximum Green (s)		65.0	65.0		17.0	17.0
Yellow Time (s)		3.0	3.0		3.0	3.0
All-Red Time (s)		1.0	1.0		1.0	1.0
Lost Time Adjust (s)		0.0	0.0		0.0	0.0
Total Lost Time (s)		4.0	4.0		4.0	4.0
Lead/Lag						
Lead-Lag Optimize?						
Vehicle Extension (s)		3.0	3.0		3.0	3.0
Recall Mode		None	None		None	None
Walk Time (s)			7.0			
Flash Dont Walk (s)			27.0			
Pedestrian Calls (#/hr)			0			
Act Effct Green (s)		17.1	17.1		11.0	11.0
Actuated g/C Ratio		0.47	0.47		0.30	0.30
v/c Ratio		0.32	0.61		0.46	0.35
Control Delay		7.4	11.0		14.7	4.1
Queue Delay		0.0	0.0		0.0	0.0
Total Delay		7.4	11.0		14.7	4.1
LOS		A	B		B	A
Approach Delay		7.4	11.0		9.7	
Approach LOS		A	B		A	
90th %ile Green (s)		24.9	24.9		15.9	15.9
90th %ile Term Code		Hold	Gap		Gap	Gap
70th %ile Green (s)		19.9	19.9		12.2	12.2
70th %ile Term Code		Hold	Gap		Gap	Gap
50th %ile Green (s)		17.6	17.6		10.6	10.6
50th %ile Term Code		Hold	Gap		Gap	Gap
30th %ile Green (s)		13.9	13.9		9.1	9.1
30th %ile Term Code		Hold	Gap		Gap	Gap
10th %ile Green (s)		10.5	10.5		7.6	7.6
10th %ile Term Code		Hold	Gap		Gap	Gap

Intersection Summary

Area Type:	Other
Cycle Length:	90
Actuated Cycle Length:	36.4
Natural Cycle:	55
Control Type:	Actuated-Uncoordinated
Maximum v/c Ratio:	0.61
Intersection Signal Delay:	9.7
Intersection Capacity Utilization	57.3%
Intersection LOS:	A
ICU Level of Service	B

Lanes, Volumes, Timings  
 4: Shiloh Road & US 101 SB Off-Ramp

Existing Conditions  
 Timing Plan: Saturday Midday Peak

Analysis Period (min) 15

90th %ile Actuated Cycle: 48.8

70th %ile Actuated Cycle: 40.1

50th %ile Actuated Cycle: 36.2

30th %ile Actuated Cycle: 31











10th %ile Actuated Cycle: 26.1

Splits and Phases: 4: Shiloh Road & US 101 SB Off-Ramp



Lanes, Volumes, Timings  
5: Caletti Ave & Shiloh Road

Existing Conditions  
Timing Plan: Saturday Midday Peak

						
Lane Group	EBT	EBR	WBL	WBT	NBL	NBR
Lane Configurations						
Traffic Volume (vph)	537	20	81	594	16	78
Future Volume (vph)	537	20	81	594	16	78
Ideal Flow (vphp)	1900	1900	1900	1900	1900	1900
Storage Length (ft)		0	68		0	0
Storage Lanes		0	1		1	1
Taper Length (ft)			50		25	
Lane Util. Factor	0.95	0.95	1.00	1.00	1.00	1.00
Ped Bike Factor						
Frt	0.995					0.850
Flt Protected			0.950		0.950	
Satd. Flow (prot)	3522	0	1770	1863	1770	1583
Flt Permitted			0.950		0.950	
Satd. Flow (perm)	3522	0	1770	1863	1770	1583
Link Speed (mph)	40			40	30	
Link Distance (ft)	1081			184	459	
Travel Time (s)	18.4			3.1	10.4	
Confl. Peds. (#/hr)					1	
Confl. Bikes (#/hr)		1				
Peak Hour Factor	0.92	0.92	0.87	0.87	0.78	0.78
Adj. Flow (vph)	584	22	93	683	21	100
Shared Lane Traffic (%)						
Lane Group Flow (vph)	606	0	93	683	21	100
Enter Blocked Intersection	No	No	No	No	No	No
Lane Alignment	Left	Right	Left	Left	Left	Right
Median Width(ft)	12			12	12	
Link Offset(ft)	0			0	0	
Crosswalk Width(ft)	16			16	16	
Two way Left Turn Lane						
Headway Factor	1.00	1.00	1.00	1.00	1.00	1.00
Turning Speed (mph)		9	15		15	9
Sign Control	Free			Free	Stop	

Intersection Summary

Area Type:	Other
Control Type:	Unsignalized
Intersection Capacity Utilization	41.3%
Analysis Period (min)	15
	ICU Level of Service A

Lanes, Volumes, Timings  
6: Conde Lane & Shiloh Road

Existing Conditions  
Timing Plan: Saturday Midday Peak



Lane Group	EBL	EBT	EBR	WBL	WBT	WBR	NBL	NBT	NBR	SBL	SBT	SBR
Lane Configurations												
Traffic Volume (vph)	29	353	1	9	393	204	1	0	6	197	0	28
Future Volume (vph)	29	353	1	9	393	204	1	0	6	197	0	28
Ideal Flow (vphpl)	1900	1900	1900	1900	1900	1900	1900	1900	1900	1900	1900	1900
Storage Length (ft)	90		0	127		0	0		0	0		40
Storage Lanes	1		0	1		0	0		0	0		1
Taper Length (ft)	70			40			25			25		
Lane Util. Factor	1.00	0.95	0.95	1.00	0.95	0.95	1.00	1.00	1.00	1.00	1.00	1.00
Ped Bike Factor					0.99							
Frt					0.949			0.887				0.850
Flt Protected	0.950			0.950				0.992			0.950	
Satd. Flow (prot)	1770	3539	0	1770	3333	0	0	1639	0	0	1770	1583
Flt Permitted	0.950			0.950				0.992			0.950	
Satd. Flow (perm)	1770	3539	0	1770	3333	0	0	1639	0	0	1770	1583
Right Turn on Red			Yes			Yes			Yes			No
Satd. Flow (RTOR)					97			89				
Link Speed (mph)		40			40			30				35
Link Distance (ft)		815			1081			418				522
Travel Time (s)		13.9			18.4			9.5				10.2
Confl. Bikes (#/hr)						2						
Peak Hour Factor	0.96	0.96	0.96	0.91	0.91	0.91	0.58	0.58	0.58	0.78	0.78	0.78
Adj. Flow (vph)	30	368	1	10	432	224	2	0	10	253	0	36
Shared Lane Traffic (%)												
Lane Group Flow (vph)	30	369	0	10	656	0	0	12	0	0	253	36
Enter Blocked Intersection	No	No	No	No	No	No	No	No	No	No	No	No
Lane Alignment	Left	Left	Right	Left	Left	Right	Left	Left	Right	Left	Left	Right
Median Width(ft)		12			12			0				0
Link Offset(ft)		0			0			0				0
Crosswalk Width(ft)		16			16			16				16
Two way Left Turn Lane												
Headway Factor	1.00	1.00	1.00	1.00	1.00	1.00	1.00	1.00	1.00	1.00	1.00	1.00
Turning Speed (mph)	15		9	15		9	15		9	15		9
Number of Detectors	1	2		1	2		1	2		1	1	1
Detector Template	Left	Thru		Left	Thru		Left	Thru		Left	Thru	Right
Leading Detector (ft)	20	100		20	100		20	100		20	30	20
Trailing Detector (ft)	0	0		0	0		0	0		0	0	0
Detector 1 Position(ft)	0	0		0	0		0	0		0	0	0
Detector 1 Size(ft)	20	6		20	6		20	6		20	30	20
Detector 1 Type	Cl+Ex	Cl+Ex		Cl+Ex	Cl+Ex		Cl+Ex	Cl+Ex		Cl+Ex	Cl+Ex	Cl+Ex
Detector 1 Channel												
Detector 1 Extend (s)	0.0	0.0		0.0	0.0		0.0	0.0		0.0	0.0	0.0
Detector 1 Queue (s)	0.0	0.0		0.0	0.0		0.0	0.0		0.0	0.0	0.0
Detector 1 Delay (s)	0.0	0.0		0.0	0.0		0.0	0.0		0.0	0.0	0.0
Detector 2 Position(ft)		94			94			94				
Detector 2 Size(ft)		6			6			6				
Detector 2 Type		Cl+Ex			Cl+Ex			Cl+Ex				
Detector 2 Channel												
Detector 2 Extend (s)		0.0			0.0			0.0				
Turn Type	Prot	NA		Prot	NA		Split	NA		Split	NA	custom

Lanes, Volumes, Timings  
6: Conde Lane & Shiloh Road

Existing Conditions  
Timing Plan: Saturday Midday Peak



Lane Group	EBL	EBT	EBR	WBL	WBT	WBR	NBL	NBT	NBR	SBL	SBT	SBR
Protected Phases	5	2		1	6		7	7		4	4	
Permitted Phases												6
Detector Phase	5	2		1	6		7	7		4	4	6
Switch Phase												
Minimum Initial (s)	8.0	8.0		8.0	8.0		10.0	10.0		11.0	11.0	8.0
Minimum Split (s)	12.0	46.0		12.0	12.0		37.0	37.0		15.0	15.0	12.0
Total Split (s)	13.0	46.0		12.0	45.0		37.0	37.0		15.0	15.0	45.0
Total Split (%)	11.8%	41.8%		10.9%	40.9%		33.6%	33.6%		13.6%	13.6%	40.9%
Maximum Green (s)	9.0	42.0		8.0	41.0		33.0	33.0		11.0	11.0	41.0
Yellow Time (s)	3.0	3.0		3.0	3.0		3.0	3.0		3.0	3.0	3.0
All-Red Time (s)	1.0	1.0		1.0	1.0		1.0	1.0		1.0	1.0	1.0
Lost Time Adjust (s)	0.0	0.0		0.0	0.0		0.0	0.0		0.0	0.0	0.0
Total Lost Time (s)	4.0	4.0		4.0	4.0		4.0	4.0		4.0	4.0	4.0
Lead/Lag	Lead	Lag		Lead	Lag							Lag
Lead-Lag Optimize?	Yes	Yes		Yes	Yes							Yes
Vehicle Extension (s)	3.0	3.0		3.0	3.0		3.0	3.0		3.0	3.0	3.0
Recall Mode	None	None		None	None		None	None		None	None	None
Walk Time (s)		7.0					7.0	7.0				
Flash Dont Walk (s)		35.0					26.0	26.0				
Pedestrian Calls (#/hr)		0					0	0				
Act Effct Green (s)	9.0	14.3		8.9	14.2			11.2			12.3	14.2
Actuated g/C Ratio	0.23	0.37		0.23	0.37			0.29			0.32	0.37
v/c Ratio	0.07	0.28		0.02	0.51			0.02			0.45	0.06
Control Delay	18.7	10.3		19.1	10.5			0.1			20.5	10.5
Queue Delay	0.0	0.0		0.0	0.0			0.0			0.0	0.0
Total Delay	18.7	10.3		19.1	10.5			0.1			20.5	10.5
LOS	B	B		B	B			A			C	B
Approach Delay		10.9			10.6			0.1			19.2	
Approach LOS		B			B			A			B	
90th %ile Green (s)	8.3	23.3		8.0	23.0		10.0	10.0		11.0	11.0	23.0
90th %ile Term Code	Gap	Hold		Max	Gap		Min	Min		Max	Max	Gap
70th %ile Green (s)	0.0	15.7		0.0	15.7		0.0	0.0		11.0	11.0	15.7
70th %ile Term Code	Skip	Hold		Skip	Gap		Skip	Skip		Max	Max	Gap
50th %ile Green (s)	0.0	13.4		0.0	13.4		0.0	0.0		11.0	11.0	13.4
50th %ile Term Code	Skip	Hold		Skip	Gap		Skip	Skip		Max	Max	Gap
30th %ile Green (s)	0.0	10.2		0.0	10.2		0.0	0.0		11.0	11.0	10.2
30th %ile Term Code	Skip	Hold		Skip	Gap		Skip	Skip		Max	Max	Gap
10th %ile Green (s)	0.0	8.2		0.0	8.2		0.0	0.0		11.0	11.0	8.2
10th %ile Term Code	Skip	Hold		Skip	Gap		Skip	Skip		Max	Max	Gap

Intersection Summary

Area Type:	Other
Cycle Length:	110
Actuated Cycle Length:	38.4
Natural Cycle:	110
Control Type:	Actuated-Uncoordinated
Maximum v/c Ratio:	0.51
Intersection Signal Delay:	12.4
Intersection LOS:	B
Intersection Capacity Utilization:	48.3%
ICU Level of Service:	A

Lanes, Volumes, Timings  
 6: Conde Lane & Shiloh Road

Existing Conditions  
 Timing Plan: Saturday Midday Peak

Analysis Period (min) 15

90th %ile Actuated Cycle: 68.3

70th %ile Actuated Cycle: 34.7

50th %ile Actuated Cycle: 32.4

30th %ile Actuated Cycle: 29.2

















10th %ile Actuated Cycle: 27.2

Splits and Phases: 6: Conde Lane & Shiloh Road

↙ Ø1 12 s	→ Ø2 46 s	↙ Ø4 15 s	↕ Ø7 37 s
↗ Ø5 13 s	← Ø6 45 s		



















Lanes, Volumes, Timings  
7: Entrance 1/Gridley Drive & Shiloh Road

Existing Conditions  
Timing Plan: Saturday Midday Peak

												
Lane Group	EBL	EBT	EBR	WBL	WBT	WBR	NBL	NBT	NBR	SBL	SBT	SBR
Lane Configurations												
Traffic Volume (vph)	20	106	0	0	92	0	0	0	0	0	0	18
Future Volume (vph)	20	106	0	0	92	0	0	0	0	0	0	18
Ideal Flow (vphpl)	1900	1900	1900	1900	1900	1900	1900	1900	1900	1900	1900	1900
Lane Util. Factor	1.00	1.00	1.00	1.00	1.00	1.00	1.00	1.00	1.00	1.00	1.00	1.00
Ped Bike Factor												
Frt												0.865
Flt Protected	0.992											
Satd. Flow (prot)	0	1848	0	0	1863	0	1863	1863	0	0	1611	0
Flt Permitted	0.992											
Satd. Flow (perm)	0	1848	0	0	1863	0	1863	1863	0	0	1611	0
Link Speed (mph)	40		40				30		30			
Link Distance (ft)	608		2146				248		715			
Travel Time (s)	10.4		36.6				5.6		16.3			
Confl. Peds. (#/hr)	1											
Confl. Bikes (#/hr)	1				3							
Peak Hour Factor	0.93	0.93	0.93	0.88	0.88	0.88	1.00	1.00	1.00	0.56	0.56	0.56
Adj. Flow (vph)	22	114	0	0	105	0	0	0	0	0	0	32
Shared Lane Traffic (%)												
Lane Group Flow (vph)	0	136	0	0	105	0	0	0	0	0	32	0
Enter Blocked Intersection	No	No	No	No	No	No	No	No	No	No	No	No
Lane Alignment	Left	Left	Right	Left	Left	Right	Left	Left	Right	Left	Left	Right
Median Width(ft)	0		0				12		12			
Link Offset(ft)	0		0				0		0			
Crosswalk Width(ft)	16		16				16		16			
Two way Left Turn Lane												
Headway Factor	1.00	1.00	1.00	1.00	1.00	1.00	1.00	1.00	1.00	1.00	1.00	1.00
Turning Speed (mph)	15		9		15		9		15		9	
Sign Control	Free				Free				Stop		Stop	
<b>Intersection Summary</b>												
Area Type:	Other											
Control Type:	Unsignalized											
Intersection Capacity Utilization	23.4%						ICU Level of Service A					
Analysis Period (min)	15											

Lanes, Volumes, Timings  
8: Old Redwood Hwy & Entrance 1

Existing Conditions  
Timing Plan: Saturday Midday Peak











												
Lane Group	EBL	EBT	EBR	WBL	WBT	WBR	NBL	NBT	NBR	SBL	SBT	SBR
Lane Configurations												
Traffic Volume (vph)	1	0	2	0	0	0	1	403	0	0	342	4
Future Volume (vph)	1	0	2	0	0	0	1	403	0	0	342	4
Ideal Flow (vphp)	1900	1900	1900	1900	1900	1900	1900	1900	1900	1900	1900	1900
Storage Length (ft)	0		0	0		0	0		0	50		0
Storage Lanes	0		0	1		0	0		0	1		0
Taper Length (ft)	25			25			25			25		
Lane Util. Factor	1.00	1.00	1.00	1.00	1.00	1.00	1.00	1.00	1.00	1.00	1.00	1.00
Ped Bike Factor												
Frt		0.916									0.998	
Flt Protected		0.982										
Satd. Flow (prot)	0	1676	0	1863	1863	0	0	1863	0	1863	1859	0
Flt Permitted		0.982										
Satd. Flow (perm)	0	1676	0	1863	1863	0	0	1863	0	1863	1859	0
Link Speed (mph)		30			30			45			45	
Link Distance (ft)		98			385			520			748	
Travel Time (s)		2.2			8.8			7.9			11.3	
Confl. Peds. (#/hr)							1		4	4		1
Confl. Bikes (#/hr)									3			9
Peak Hour Factor	0.38	0.38	0.38	1.00	1.00	1.00	0.94	0.94	0.94	0.93	0.93	0.93
Adj. Flow (vph)	3	0	5	0	0	0	1	429	0	0	368	4
Shared Lane Traffic (%)												
Lane Group Flow (vph)	0	8	0	0	0	0	0	430	0	0	372	0
Enter Blocked Intersection	No	No	No	No	No	No	No	No	No	No	No	No
Lane Alignment	Left	Left	Right	Left	Left	Right	Left	Left	Right	Left	Left	Right
Median Width(ft)		12			12			12			12	
Link Offset(ft)		0			0			0			0	
Crosswalk Width(ft)		16			16			16			16	
Two way Left Turn Lane												
Headway Factor	1.00	1.00	1.00	1.00	1.00	1.00	1.00	1.00	1.00	1.00	1.00	1.00
Turning Speed (mph)	15		9	15		9	15		9	15		9
Sign Control		Stop			Stop			Free			Free	

Intersection Summary	
Area Type:	Other
Control Type:	Unsignalized
Intersection Capacity Utilization	32.0%
Analysis Period (min)	15
	ICU Level of Service A



Lanes, Volumes, Timings  
9: Entrance 2 & Shiloh Road

Existing Conditions  
Timing Plan: Saturday Midday Peak

						
Lane Group	EBT	EBR	WBL	WBT	NBL	NBR
Lane Configurations						
Traffic Volume (vph)	92	0	0	86	0	0
Future Volume (vph)	92	0	0	86	0	0
Ideal Flow (vphpl)	1900	1900	1900	1900	1900	1900
Lane Util. Factor	1.00	1.00	1.00	1.00	1.00	1.00
Ped Bike Factor						
Frt						
Flt Protected						
Satd. Flow (prot)	1863	0	0	1863	1863	1863
Flt Permitted						
Satd. Flow (perm)	1863	0	0	1863	1863	1863
Link Speed (mph)	40			40	30	
Link Distance (ft)	2146			134	402	
Travel Time (s)	36.6			2.3	9.1	
Confl. Peds. (#/hr)		1				
Peak Hour Factor	0.88	0.88	0.80	0.80	1.00	1.00
Adj. Flow (vph)	105	0	0	108	0	0
Shared Lane Traffic (%)						
Lane Group Flow (vph)	105	0	0	108	0	0
Enter Blocked Intersection	No	No	No	No	No	No
Lane Alignment	Left	Right	Left	Left	Left	Right
Median Width(ft)	0			0	12	
Link Offset(ft)	0			0	0	
Crosswalk Width(ft)	16			16	16	
Two way Left Turn Lane						
Headway Factor	1.00	1.00	1.00	1.00	1.00	1.00
Turning Speed (mph)		9	15		15	9
Sign Control	Free			Free	Stop	
<b>Intersection Summary</b>						
Area Type:	Other					
Control Type:	Unsignalized					
Intersection Capacity Utilization	8.5%			ICU Level of Service A		
Analysis Period (min)	15					

Lanes, Volumes, Timings

Existing Conditions

10: US 101 NB Off Ramp/Lakewood Drive & Old Redwood Highway Timing Plan: Saturday Midday Peak



Lane Group	EBL	EBT	EBR	WBL	WBT	WBR	NBL	NBT	NBR	SBL	SBT	SBR
Lane Configurations	↔↔	↑			↑↑		↔	↔↔		↔↔		↔
Traffic Volume (vph)	252	275	0	0	441	242	281	266	125	214	0	615
Future Volume (vph)	252	275	0	0	441	242	281	266	125	214	0	615
Ideal Flow (vphpl)	1900	1900	1900	1900	1900	1900	1900	1900	1900	1900	1900	1900
Storage Length (ft)	155		0	0		0	270		150	120		0
Storage Lanes	1		0	0		0	1		1	1		1
Taper Length (ft)	50			25			165			75		
Lane Util. Factor	0.97	1.00	1.00	1.00	0.95	0.95	0.91	0.91	0.95	0.97	1.00	1.00
Ped Bike Factor	1.00				0.99			1.00		1.00		
Fr <sub>t</sub>					0.947			0.958				0.850
Fl <sub>t</sub> Protected	0.950						0.950	0.994		0.950		
Satd. Flow (prot)	3433	1863	0	0	3332	0	1610	3217	0	3433	0	1583
Fl <sub>t</sub> Permitted	0.950						0.950	0.994		0.950		
Satd. Flow (perm)	3429	1863	0	0	3332	0	1610	3217	0	3430	0	1583
Right Turn on Red			Yes			Yes			Yes			Yes
Satd. Flow (RTOR)					120			61				324
Link Speed (mph)		35			35			30				30
Link Distance (ft)		226			617			716				478
Travel Time (s)		4.4			12.0			16.3				10.9
Confl. Peds. (#/hr)	2		1	1		2			1	1		
Confl. Bikes (#/hr)			10			3						
Peak Hour Factor	0.95	0.95	0.95	0.89	0.89	0.89	0.98	0.98	0.98	0.88	0.88	0.88
Adj. Flow (vph)	265	289	0	0	496	272	287	271	128	243	0	699
Shared Lane Traffic (%)							20%					
Lane Group Flow (vph)	265	289	0	0	768	0	230	456	0	243	0	699
Enter Blocked Intersection	No	No	No	No	No	No	No	No	No	No	No	No
Lane Alignment	Left	Left	Right	Left	Left	Right	Left	Left	Right	Left	Left	Right
Median Width(ft)		24			24			24				24
Link Offset(ft)		0			0			0				0
Crosswalk Width(ft)		16			16			16				16
Two way Left Turn Lane												
Headway Factor	1.00	1.00	1.00	1.00	1.00	1.00	1.00	1.00	1.00	1.00	1.00	1.00
Turning Speed (mph)	15		9	15		9	15		9	15		9
Number of Detectors	1	2			2		1	2		1		1
Detector Template	Left	Thru			Thru		Left	Thru		Left		Right
Leading Detector (ft)	20	100			100		20	100		20		20
Trailing Detector (ft)	0	0			0		0	0		0		0
Detector 1 Position(ft)	0	0			0		0	0		0		0
Detector 1 Size(ft)	20	6			6		20	6		20		20
Detector 1 Type	Cl+Ex	Cl+Ex			Cl+Ex		Cl+Ex	Cl+Ex		Cl+Ex		Cl+Ex
Detector 1 Channel												
Detector 1 Extend (s)	0.0	0.0			0.0		0.0	0.0		0.0		0.0
Detector 1 Queue (s)	0.0	0.0			0.0		0.0	0.0		0.0		0.0
Detector 1 Delay (s)	0.0	0.0			0.0		0.0	0.0		0.0		0.0
Detector 2 Position(ft)		94			94			94				
Detector 2 Size(ft)		6			6			6				
Detector 2 Type		Cl+Ex			Cl+Ex			Cl+Ex				
Detector 2 Channel												
Detector 2 Extend (s)		0.0			0.0			0.0				

Lanes, Volumes, Timings

Existing Conditions

10: US 101 NB Off Ramp/Lakewood Drive & Old Redwood Highway Timing Plan: Saturday Midday Peak



Lane Group	EBL	EBT	EBR	WBL	WBT	WBR	NBL	NBT	NBR	SBL	SBT	SBR
Turn Type	Prot	NA			NA		Split	NA		Prot		pm+ov
Protected Phases	5	2			6		8	8		7		5
Permitted Phases												5 8
Detector Phase	5	2			6		8	8		7		5
Switch Phase												
Minimum Initial (s)	7.0	10.0			10.0		10.0	10.0		7.0		7.0
Minimum Split (s)	11.0	32.1			32.1		33.7	33.7		11.0		11.0
Total Split (s)	12.0	45.3			33.3		33.7	33.7		11.0		12.0
Total Split (%)	13.3%	50.3%			37.0%		37.4%	37.4%		12.2%		13.3%
Maximum Green (s)	8.0	40.2			28.2		29.0	29.0		7.0		8.0
Yellow Time (s)	3.0	4.1			4.1		3.7	3.7		3.0		3.0
All-Red Time (s)	1.0	1.0			1.0		1.0	1.0		1.0		1.0
Lost Time Adjust (s)	0.0	0.0			0.0		0.0	0.0		0.0		0.0
Total Lost Time (s)	4.0	5.1			5.1		4.7	4.7		4.0		4.0
Lead/Lag	Lead				Lag		Lag	Lag		Lead		Lead
Lead-Lag Optimize?	Yes				Yes		Yes	Yes		Yes		Yes
Vehicle Extension (s)	3.0	3.0			3.0		3.0	3.0		3.0		3.0
Recall Mode	None	Max			Max		None	None		None		None
Walk Time (s)		7.0			7.0		7.0	7.0				
Flash Dont Walk (s)		20.0			17.0		22.0	22.0				
Pedestrian Calls (#/hr)		0			0		0	0				
Act Effct Green (s)	8.0	40.4			28.4		18.0	18.0		7.0		30.8
Actuated g/C Ratio	0.10	0.51			0.36		0.23	0.23		0.09		0.39
v/c Ratio	0.76	0.30			0.61		0.63	0.59		0.80		0.86
Control Delay	52.0	13.7			20.8		35.3	26.2		57.8		23.5
Queue Delay	0.0	0.0			0.0		0.0	0.0		0.0		0.0
Total Delay	52.0	13.7			20.8		35.3	26.2		57.8		23.5
LOS	D	B			C		D	C		E		C
Approach Delay		32.0			20.8			29.3				32.3
Approach LOS		C			C			C				C
90th %ile Green (s)	8.0	40.2			28.2		27.3	27.3		7.0		8.0
90th %ile Term Code	Max	MaxR			MaxR		Gap	Gap		Max		Max
70th %ile Green (s)	8.0	40.2			28.2		21.8	21.8		7.0		8.0
70th %ile Term Code	Max	MaxR			MaxR		Gap	Gap		Max		Max
50th %ile Green (s)	8.0	40.2			28.2		18.0	18.0		7.0		8.0
50th %ile Term Code	Max	MaxR			MaxR		Gap	Gap		Max		Max
30th %ile Green (s)	8.0	40.2			28.2		14.4	14.4		7.0		8.0
30th %ile Term Code	Max	MaxR			MaxR		Gap	Gap		Max		Max
10th %ile Green (s)	8.0	40.2			28.2		10.3	10.3		7.0		8.0
10th %ile Term Code	Max	MaxR			MaxR		Gap	Gap		Max		Max

Intersection Summary

Area Type:	Other
Cycle Length:	90
Actuated Cycle Length:	79.4
Natural Cycle:	90
Control Type:	Actuated-Uncoordinated
Maximum v/c Ratio:	0.86
Intersection Signal Delay:	28.5
Intersection LOS:	C

Lanes, Volumes, Timings

Existing Conditions

10: US 101 NB Off Ramp/Lakewood Drive & Old Redwood Highway Timing Plan: Saturday Midday Peak

Intersection Capacity Utilization 83.0% ICU Level of Service E

Analysis Period (min) 15

90th %ile Actuated Cycle: 88.3

70th %ile Actuated Cycle: 82.8

50th %ile Actuated Cycle: 79

30th %ile Actuated Cycle: 75.4

10th %ile Actuated Cycle: 71.3

Splits and Phases: 10: US 101 NB Off Ramp/Lakewood Drive & Old Redwood Highway

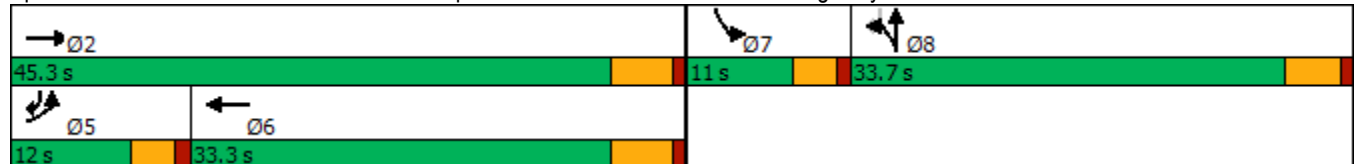

Lanes, Volumes, Timings  
 11: Old Redwood Highway & US 101 NB On Ramp

Existing Conditions  
 Timing Plan: Saturday Midday Peak



Lane Group	EBL	EBT	WBT	WBR	SBL	SBR
Lane Configurations						
Traffic Volume (vph)	76	531	1150	189	0	0
Future Volume (vph)	76	531	1150	189	0	0
Ideal Flow (vphpl)	1900	1900	1900	1900	1900	1900
Storage Length (ft)	245			0	0	0
Storage Lanes	1			0	0	0
Taper Length (ft)	50				25	
Lane Util. Factor	1.00	0.95	0.95	0.95	1.00	1.00
Ped Bike Factor						
Frt			0.979			
Flt Protected	0.950					
Satd. Flow (prot)	1770	3539	3465	0	0	0
Flt Permitted	0.950					
Satd. Flow (perm)	1770	3539	3465	0	0	0
Link Speed (mph)		35	35		30	
Link Distance (ft)		531	226		299	
Travel Time (s)		10.3	4.4		6.8	
Confl. Peds. (#/hr)	8			8		
Confl. Bikes (#/hr)				4		
Peak Hour Factor	0.96	0.96	0.92	0.92	0.25	0.25
Adj. Flow (vph)	79	553	1250	205	0	0
Shared Lane Traffic (%)						
Lane Group Flow (vph)	79	553	1455	0	0	0
Enter Blocked Intersection	No	No	No	No	No	No
Lane Alignment	Left	Left	Left	Right	Left	Right
Median Width(ft)		12	12		0	
Link Offset(ft)		0	0		0	
Crosswalk Width(ft)		16	16		16	
Two way Left Turn Lane						
Headway Factor	1.00	1.00	1.00	1.00	1.00	1.00
Turning Speed (mph)	15			9	15	9
Sign Control		Free	Free		Free	

Intersection Summary	
Area Type:	Other
Control Type:	Unsignalized
Intersection Capacity Utilization	66.6% ICU Level of Service C
Analysis Period (min)	15

Lanes, Volumes, Timings

Existing Conditions

12: US 101 SB On Ramp/US 101 SB Off Ramp & Old Redwood Highway Timing Plan: Saturday Midday Peak



Lane Group	EBL	EBT	EBR	WBL	WBT	WBR	NBL	NBT	NBR	SBL	SBT	SBR
Lane Configurations		↑↑	↗	↖	↑↑					↖	↕	
Traffic Volume (vph)	0	483	368	428	718	0	0	0	0	133	1	76
Future Volume (vph)	0	483	368	428	718	0	0	0	0	133	1	76
Ideal Flow (vphpl)	1900	1900	1900	1900	1900	1900	1900	1900	1900	1900	1900	1900
Storage Length (ft)	0		0	250		0	0		0	420		0
Storage Lanes	0		1	0		0	0		0	1		0
Taper Length (ft)	25			165			25			75		
Lane Util. Factor	1.00	0.95	1.00	1.00	0.95	1.00	1.00	1.00	1.00	0.95	0.95	1.00
Ped Bike Factor			0.98	1.00								
Frt			0.850								0.886	
Flt Protected				0.950						0.950	0.988	
Satd. Flow (prot)	0	3539	1583	1770	3539	0	0	0	0	1681	1549	0
Flt Permitted				0.950						0.950	0.988	
Satd. Flow (perm)	0	3539	1553	1768	3539	0	0	0	0	1681	1549	0
Right Turn on Red			Yes			Yes			Yes			Yes
Satd. Flow (RTOR)			379								106	
Link Speed (mph)		35			35			30			30	
Link Distance (ft)		423			531			621			831	
Travel Time (s)		8.2			10.3			14.1			18.9	
Confl. Peds. (#/hr)	11		2	2		11						
Confl. Bikes (#/hr)			10			2						
Peak Hour Factor	0.97	0.97	0.97	0.96	0.96	0.96	0.25	0.25	0.25	0.72	0.72	0.72
Adj. Flow (vph)	0	498	379	446	748	0	0	0	0	185	1	106
Shared Lane Traffic (%)										18%		
Lane Group Flow (vph)	0	498	379	446	748	0	0	0	0	152	140	0
Enter Blocked Intersection	No	No	No	No	No	No	No	No	No	No	No	No
Lane Alignment	Left	Left	Right	Left	Left	Right	Left	Left	Right	Left	Left	Right
Median Width(ft)		24			24			12			12	
Link Offset(ft)		0			0			0			0	
Crosswalk Width(ft)		16			16			16			16	
Two way Left Turn Lane												
Headway Factor	1.00	1.00	1.00	1.00	1.00	1.00	1.00	1.00	1.00	1.00	1.00	1.00
Turning Speed (mph)	15		9	15		9	15		9	15		9
Number of Detectors		2	1	1	2					1	2	
Detector Template		Thru	Right	Left	Thru					Left	Thru	
Leading Detector (ft)		100	20	20	100					20	100	
Trailing Detector (ft)		0	0	0	0					0	0	
Detector 1 Position(ft)		0	0	0	0					0	0	
Detector 1 Size(ft)		6	20	20	6					20	6	
Detector 1 Type		Cl+Ex	Cl+Ex	Cl+Ex	Cl+Ex					Cl+Ex	Cl+Ex	
Detector 1 Channel												
Detector 1 Extend (s)		0.0	0.0	0.0	0.0					0.0	0.0	
Detector 1 Queue (s)		0.0	0.0	0.0	0.0					0.0	0.0	
Detector 1 Delay (s)		0.0	0.0	0.0	0.0					0.0	0.0	
Detector 2 Position(ft)		94			94						94	
Detector 2 Size(ft)		6			6						6	
Detector 2 Type		Cl+Ex			Cl+Ex						Cl+Ex	
Detector 2 Channel												
Detector 2 Extend (s)		0.0			0.0						0.0	

Lanes, Volumes, Timings

Existing Conditions

12: US 101 SB On Ramp/US 101 SB Off Ramp & Old Redwood Highway Timing Plan: Saturday Midday Peak

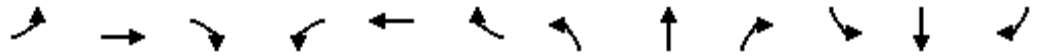

Lane Group	EBL	EBT	EBR	WBL	WBT	WBR	NBL	NBT	NBR	SBL	SBT	SBR
Turn Type		NA	Perm	Prot	NA					Perm	NA	
Protected Phases		6		5	2						8	
Permitted Phases			6							8		
Detector Phase		6	6	5	2					8	8	
Switch Phase												
Minimum Initial (s)		10.0	10.0	7.0	10.0					10.0	10.0	
Minimum Split (s)		32.1	32.1	11.0	38.1					14.7	14.7	
Total Split (s)		32.3	32.3	23.0	55.3					14.7	14.7	
Total Split (%)		46.1%	46.1%	32.9%	79.0%					21.0%	21.0%	
Maximum Green (s)		27.2	27.2	19.0	50.2					10.0	10.0	
Yellow Time (s)		4.1	4.1	3.0	4.1					3.7	3.7	
All-Red Time (s)		1.0	1.0	1.0	1.0					1.0	1.0	
Lost Time Adjust (s)		0.0	0.0	0.0	0.0					0.0	0.0	
Total Lost Time (s)		5.1	5.1	4.0	5.1					4.7	4.7	
Lead/Lag		Lag	Lag	Lead								
Lead-Lag Optimize?		Yes	Yes	Yes								
Vehicle Extension (s)		3.0	3.0	3.0	3.0					3.0	3.0	
Recall Mode		Max	Max	None	Max					None	None	
Walk Time (s)		7.0	7.0		7.0							
Flash Dont Walk (s)		20.0	20.0		25.0							
Pedestrian Calls (#/hr)		0	0		0							
Act Effct Green (s)		27.3	27.3	18.9	50.2					10.0	10.0	
Actuated g/C Ratio		0.39	0.39	0.27	0.72					0.14	0.14	
v/c Ratio		0.36	0.45	0.94	0.29					0.63	0.45	
Control Delay		16.1	3.8	55.6	3.9					41.9	14.8	
Queue Delay		0.0	0.0	0.0	0.0					0.0	0.0	
Total Delay		16.1	3.8	55.6	3.9					41.9	14.8	
LOS		B	A	E	A					D	B	
Approach Delay		10.8			23.2						28.9	
Approach LOS		B			C						C	
90th %ile Green (s)		27.2	27.2	19.0	50.2					10.0	10.0	
90th %ile Term Code		MaxR	MaxR	Max	MaxR					Max	Max	
70th %ile Green (s)		27.2	27.2	19.0	50.2					10.0	10.0	
70th %ile Term Code		MaxR	MaxR	Max	MaxR					Max	Max	
50th %ile Green (s)		27.2	27.2	19.0	50.2					10.0	10.0	
50th %ile Term Code		MaxR	MaxR	Max	MaxR					Max	Max	
30th %ile Green (s)		27.2	27.2	19.0	50.2					10.0	10.0	
30th %ile Term Code		MaxR	MaxR	Max	MaxR					Max	Max	
10th %ile Green (s)		27.8	27.8	18.4	50.2					10.0	10.0	
10th %ile Term Code		Hold	Hold	Gap	MaxR					Max	Max	

Intersection Summary

Area Type: Other  
 Cycle Length: 70  
 Actuated Cycle Length: 70  
 Natural Cycle: 70  
 Control Type: Actuated-Uncoordinated  
 Maximum v/c Ratio: 0.94  
 Intersection Signal Delay: 19.3  
 Intersection LOS: B

Lanes, Volumes, Timings

Existing Conditions

12: US 101 SB On Ramp/US 101 SB Off Ramp & Old Redwood Highway Timing Plan: Saturday Midday Peak

Intersection Capacity Utilization 66.6% ICU Level of Service C

Analysis Period (min) 15

90th %ile Actuated Cycle: 70

70th %ile Actuated Cycle: 70

50th %ile Actuated Cycle: 70

30th %ile Actuated Cycle: 70

10th %ile Actuated Cycle: 70

Splits and Phases: 12: US 101 SB On Ramp/US 101 SB Off Ramp & Old Redwood Highway

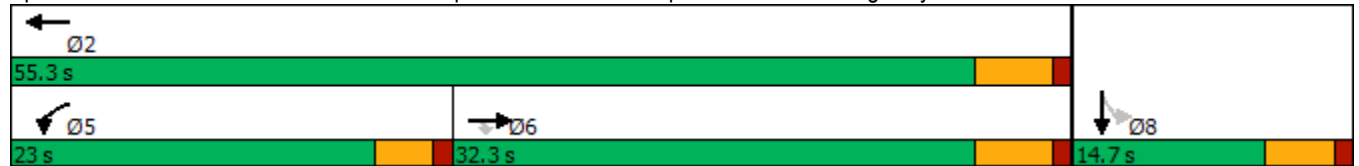

























Appendix C – Existing plus Alternative A Project Conditions  
Intersection Level of Service Worksheets

HCM 6th Signalized Intersection Summary  
 1: Old Redwood Hwy & Shiloh Road

Existing Project Alter. A Conditions  
 Timing Plan: A.M. PEAK

												
Movement	EBL	EBT	EBR	WBL	WBT	WBR	NBL	NBT	NBR	SBL	SBT	SBR
Lane Configurations												
Traffic Volume (veh/h)	108	274	104	22	170	26	92	124	34	35	233	169
Future Volume (veh/h)	108	274	104	22	170	26	92	124	34	35	233	169
Initial Q (Qb), veh	0	0	0	0	0	0	0	0	0	0	0	0
Ped-Bike Adj(A_pbT)	1.00		1.00	1.00		1.00	1.00		1.00	1.00		0.98
Parking Bus, Adj	1.00	1.00	1.00	1.00	1.00	1.00	1.00	1.00	1.00	1.00	1.00	1.00
Work Zone On Approach		No			No			No			No	
Adj Sat Flow, veh/h/ln	1870	1870	1870	1870	1870	1870	1870	1870	1870	1870	1870	1870
Adj Flow Rate, veh/h	133	338	128	25	191	29	99	133	37	41	274	199
Peak Hour Factor	0.81	0.81	0.81	0.89	0.89	0.89	0.93	0.93	0.93	0.85	0.85	0.85
Percent Heavy Veh, %	2	2	2	2	2	2	2	2	2	2	2	2
Cap, veh/h	437	458	389	35	268	258	160	396	335	154	389	323
Arrive On Green	0.25	0.25	0.25	0.16	0.16	0.16	0.09	0.21	0.21	0.09	0.21	0.21
Sat Flow, veh/h	1781	1870	1585	215	1644	1585	1781	1870	1585	1781	1870	1551
Grp Volume(v), veh/h	133	338	128	216	0	29	99	133	37	41	274	199
Grp Sat Flow(s),veh/h/ln	1781	1870	1585	1860	0	1585	1781	1870	1585	1781	1870	1551
Q Serve(g_s), s	3.5	9.6	3.8	6.4	0.0	0.9	3.1	3.5	1.1	1.2	7.9	6.7
Cycle Q Clear(g_c), s	3.5	9.6	3.8	6.4	0.0	0.9	3.1	3.5	1.1	1.2	7.9	6.7
Prop In Lane	1.00		1.00	0.12		1.00	1.00		1.00	1.00		1.00
Lane Grp Cap(c), veh/h	437	458	389	303	0	258	160	396	335	154	389	323
V/C Ratio(X)	0.30	0.74	0.33	0.71	0.00	0.11	0.62	0.34	0.11	0.27	0.70	0.62
Avail Cap(c_a), veh/h	939	986	836	1222	0	1041	447	1407	1192	185	1132	938
HCM Platoon Ratio	1.00	1.00	1.00	1.00	1.00	1.00	1.00	1.00	1.00	1.00	1.00	1.00
Upstream Filter(I)	1.00	1.00	1.00	1.00	0.00	1.00	1.00	1.00	1.00	1.00	1.00	1.00
Uniform Delay (d), s/veh	17.8	20.1	17.9	22.9	0.0	20.6	25.4	19.4	18.4	24.7	21.2	20.8
Incr Delay (d2), s/veh	0.4	2.3	0.5	3.1	0.0	0.2	3.9	0.5	0.1	0.9	2.3	1.9
Initial Q Delay(d3),s/veh	0.0	0.0	0.0	0.0	0.0	0.0	0.0	0.0	0.0	0.0	0.0	0.0
%ile BackOfQ(50%),veh/ln	1.3	3.9	1.2	2.7	0.0	0.3	1.3	1.4	0.4	0.5	3.3	2.3
Unsig. Movement Delay, s/veh												
LnGrp Delay(d),s/veh	18.2	22.4	18.4	26.0	0.0	20.8	29.2	19.9	18.6	25.6	23.6	22.7
LnGrp LOS	B	C	B	C	A	C	C	B	B	C	C	C
Approach Vol, veh/h		599			245			269			514	
Approach Delay, s/veh		20.6			25.4			23.1			23.4	
Approach LOS		C			C			C			C	
Timer - Assigned Phs		2	3	4		6	7	8				
Phs Duration (G+Y+Rc), s		18.7	8.7	16.5		13.9	8.5	16.7				
Change Period (Y+Rc), s		4.5	3.5	4.5		4.5	3.5	4.5				
Max Green Setting (Gmax), s		30.5	14.5	35.0		38.0	6.0	43.5				
Max Q Clear Time (g_c+I1), s		11.6	5.1	9.9		8.4	3.2	5.5				
Green Ext Time (p_c), s		2.5	0.1	2.2		1.3	0.0	0.8				
<b>Intersection Summary</b>												
HCM 6th Ctrl Delay				22.6								
HCM 6th LOS				C								

# HCM Signalized Intersection Capacity Analysis

## 2: Shiloh Road & Hembree Ln

Existing Project Alter. A Conditions  
Timing Plan: A.M. PEAK

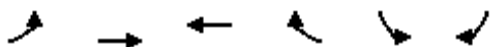

Movement	EBL	EBT	WBT	WBR	SBL	SBR
Lane Configurations	↶↷	↶	↶↷		↶	↶
Traffic Volume (vph)	305	434	392	68	71	361
Future Volume (vph)	305	434	392	68	71	361
Ideal Flow (vphpl)	1900	1900	1900	1900	1900	1900
Total Lost time (s)	4.0	4.0	4.0		4.0	4.0
Lane Util. Factor	0.97	1.00	0.95		1.00	1.00
Frt	1.00	1.00	0.98		1.00	0.85
Flt Protected	0.95	1.00	1.00		0.95	1.00
Satd. Flow (prot)	3433	1863	3461		1770	1583
Flt Permitted	0.95	1.00	1.00		0.95	1.00
Satd. Flow (perm)	3433	1863	3461		1770	1583
Peak-hour factor, PHF	0.88	0.88	0.97	0.97	0.94	0.94
Adj. Flow (vph)	347	493	404	70	76	384
RTOR Reduction (vph)	0	0	19	0	0	209
Lane Group Flow (vph)	347	493	455	0	76	175
Turn Type	Prot	NA	NA		Perm	pm+ov
Protected Phases	5	2	6			5
Permitted Phases					4	4 5
Actuated Green, G (s)	10.8	27.2	12.4		4.1	14.9
Effective Green, g (s)	10.8	27.2	12.4		4.1	14.9
Actuated g/C Ratio	0.27	0.69	0.32		0.10	0.38
Clearance Time (s)	4.0	4.0	4.0		4.0	4.0
Vehicle Extension (s)	3.0	3.0	3.0		3.0	3.0
Lane Grp Cap (vph)	943	1289	1092		184	761
v/s Ratio Prot	0.10	c0.26	0.13			0.06
v/s Ratio Perm					c0.04	0.05
v/c Ratio	0.37	0.38	0.42		0.41	0.23
Uniform Delay, d1	11.5	2.5	10.6		16.5	8.3
Progression Factor	1.00	1.00	1.00		1.00	1.00
Incremental Delay, d2	0.2	0.2	0.3		1.5	0.2
Delay (s)	11.7	2.7	10.9		18.0	8.5
Level of Service	B	A	B		B	A
Approach Delay (s)		6.4	10.9		10.0	
Approach LOS		A	B		B	

### Intersection Summary

HCM 2000 Control Delay	8.6	HCM 2000 Level of Service	A
HCM 2000 Volume to Capacity ratio	0.44		
Actuated Cycle Length (s)	39.3	Sum of lost time (s)	12.0
Intersection Capacity Utilization	42.0%	ICU Level of Service	A
Analysis Period (min)	15		

c Critical Lane Group

HCM 6th Signalized Intersection Summary  
 3: US 101 NB Off-Ramp & Shiloh Road

Existing Project Alter. A Conditions  
 Timing Plan: A.M. PEAK



Movement	EBT	EBR	WBL	WBT	NBL	NBR
Lane Configurations	↑↑			↑	↘	↗
Traffic Volume (veh/h)	302	0	0	581	432	450
Future Volume (veh/h)	302	0	0	581	432	450
Initial Q (Qb), veh	0	0	0	0	0	0
Ped-Bike Adj(A_pbT)		1.00	1.00		1.00	1.00
Parking Bus, Adj	1.00	1.00	1.00	1.00	1.00	1.00
Work Zone On Approach	No			No	No	
Adj Sat Flow, veh/h/ln	1870	0	0	1870	1870	1870
Adj Flow Rate, veh/h	332	0	0	646	568	592
Peak Hour Factor	0.91	0.91	0.90	0.90	0.76	0.76
Percent Heavy Veh, %	2	0	0	2	2	2
Cap, veh/h	1508	0	0	793	727	1139
Arrive On Green	0.42	0.00	0.00	0.42	0.41	0.41
Sat Flow, veh/h	3741	0	0	1870	1781	2790
Grp Volume(v), veh/h	332	0	0	646	568	592
Grp Sat Flow(s),veh/h/ln	1777	0	0	1870	1781	1395
Q Serve(g_s), s	2.8	0.0	0.0	14.5	13.2	7.6
Cycle Q Clear(g_c), s	2.8	0.0	0.0	14.5	13.2	7.6
Prop In Lane		0.00	0.00		1.00	1.00
Lane Grp Cap(c), veh/h	1508	0	0	793	727	1139
V/C Ratio(X)	0.22	0.00	0.00	0.81	0.78	0.52
Avail Cap(c_a), veh/h	2456	0	0	1292	1156	1811
HCM Platoon Ratio	1.00	1.00	1.00	1.00	1.00	1.00
Upstream Filter(I)	1.00	0.00	0.00	1.00	1.00	1.00
Uniform Delay (d), s/veh	8.7	0.0	0.0	12.1	12.3	10.6
Incr Delay (d2), s/veh	0.1	0.0	0.0	2.1	1.9	0.4
Initial Q Delay(d3),s/veh	0.0	0.0	0.0	0.0	0.0	0.0
%ile BackOfQ(50%),veh/ln	0.8	0.0	0.0	4.7	4.5	1.9
Unsig. Movement Delay, s/veh						
LnGrp Delay(d),s/veh	8.8	0.0	0.0	14.2	14.1	11.0
LnGrp LOS	A	A	A	B	B	B
Approach Vol, veh/h	332			646	1160	
Approach Delay, s/veh	8.8			14.2	12.5	
Approach LOS	A			B	B	
Timer - Assigned Phs		2			6	8
Phs Duration (G+Y+Rc), s		24.3			24.3	23.5
Change Period (Y+Rc), s		4.0			4.0	4.0
Max Green Setting (Gmax), s		33.0			33.0	31.0
Max Q Clear Time (g_c+I1), s		4.8			16.5	15.2
Green Ext Time (p_c), s		2.1			3.8	4.3
<b>Intersection Summary</b>						
HCM 6th Ctrl Delay			12.5			
HCM 6th LOS			B			

HCM Signalized Intersection Capacity Analysis  
 4: Shiloh Road & US 101 SB Off-Ramp

Existing Project Alter. A Conditions  
 Timing Plan: A.M. PEAK



Movement	EBL	EBT	WBT	WBR	SBL	SBR
Lane Configurations		↑	↑		↘	↗
Traffic Volume (vph)	0	240	594	0	150	138
Future Volume (vph)	0	240	594	0	150	138
Ideal Flow (vphpl)	1900	1900	1900	1900	1900	1900
Total Lost time (s)		4.0	4.0		4.0	4.0
Lane Util. Factor		1.00	1.00		1.00	1.00
Frt		1.00	1.00		1.00	0.85
Flt Protected		1.00	1.00		0.95	1.00
Satd. Flow (prot)		1863	1863		1770	1583
Flt Permitted		1.00	1.00		0.95	1.00
Satd. Flow (perm)		1863	1863		1770	1583
Peak-hour factor, PHF	0.93	0.93	0.91	0.91	0.92	0.92
Adj. Flow (vph)	0	258	653	0	163	150
RTOR Reduction (vph)	0	0	0	0	0	113
Lane Group Flow (vph)	0	258	653	0	163	37
Turn Type		NA	NA		Perm	Perm
Protected Phases		2	6			
Permitted Phases					4	4
Actuated Green, G (s)		19.9	19.9		9.1	9.1
Effective Green, g (s)		19.9	19.9		9.1	9.1
Actuated g/C Ratio		0.54	0.54		0.25	0.25
Clearance Time (s)		4.0	4.0		4.0	4.0
Vehicle Extension (s)		3.0	3.0		3.0	3.0
Lane Grp Cap (vph)		1001	1001		435	389
v/s Ratio Prot		0.14	c0.35			
v/s Ratio Perm					c0.09	0.02
v/c Ratio		0.26	0.65		0.37	0.09
Uniform Delay, d1		4.6	6.1		11.6	10.8
Progression Factor		1.00	1.00		1.00	1.00
Incremental Delay, d2		0.1	1.5		0.5	0.1
Delay (s)		4.7	7.6		12.1	10.9
Level of Service		A	A		B	B
Approach Delay (s)		4.7	7.6		11.5	
Approach LOS		A	A		B	

Intersection Summary			
HCM 2000 Control Delay	8.0	HCM 2000 Level of Service	A
HCM 2000 Volume to Capacity ratio	0.56		
Actuated Cycle Length (s)	37.0	Sum of lost time (s)	8.0
Intersection Capacity Utilization	60.1%	ICU Level of Service	B
Analysis Period (min)	15		

c Critical Lane Group

Intersection						
Int Delay, s/veh	2.6					
Movement	EBT	EBR	WBL	WBT	NBL	NBR
Lane Configurations	↑↑		↘	↑	↘	↘
Traffic Vol, veh/h	532	22	177	557	7	121
Future Vol, veh/h	532	22	177	557	7	121
Conflicting Peds, #/hr	0	0	0	0	0	0
Sign Control	Free	Free	Free	Free	Stop	Stop
RT Channelized	-	None	-	None	-	None
Storage Length	-	-	68	-	0	0
Veh in Median Storage, #	0	-	-	0	0	-
Grade, %	0	-	-	0	0	-
Peak Hour Factor	96	96	87	87	84	84
Heavy Vehicles, %	2	2	2	2	2	2
Mvmt Flow	554	23	203	640	8	144



















Major/Minor	Major1	Major2	Minor1		
Conflicting Flow All	0	0	577	0	1612 289
Stage 1	-	-	-	-	566 -
Stage 2	-	-	-	-	1046 -
Critical Hdwy	-	-	4.13	-	6.63 6.93
Critical Hdwy Stg 1	-	-	-	-	5.83 -
Critical Hdwy Stg 2	-	-	-	-	5.43 -
Follow-up Hdwy	-	-	2.219	-	3.519 3.319
Pot Cap-1 Maneuver	-	-	995	-	104 708
Stage 1	-	-	-	-	533 -
Stage 2	-	-	-	-	337 -
Platoon blocked, %	-	-	-	-	-
Mov Cap-1 Maneuver	-	-	995	-	83 708
Mov Cap-2 Maneuver	-	-	-	-	83 -
Stage 1	-	-	-	-	533 -
Stage 2	-	-	-	-	268 -

Approach	EB	WB	NB
HCM Control Delay, s	0	2.3	13.7
HCM LOS			B

Minor Lane/Major Mvmt	NBLn1	NBLn2	EBT	EBR	WBL	WBT
Capacity (veh/h)	83	708	-	-	995	-
HCM Lane V/C Ratio	0.1	0.203	-	-	0.204	-
HCM Control Delay (s)	53.2	11.4	-	-	9.5	-
HCM Lane LOS	F	B	-	-	A	-
HCM 95th %tile Q(veh)	0.3	0.8	-	-	0.8	-

HCM Signalized Intersection Capacity Analysis  
6: Conde Lane & Shiloh Road

Existing Project Alter. A Conditions  
Timing Plan: A.M. PEAK

													
Movement	EBL	EBT	EBR	WBL	WBT	WBR	NBL	NBT	NBR	SBL	SBT	SBR	
Lane Configurations													
Traffic Volume (vph)	25	337	5	9	361	204	4	0	12	205	1	35	
Future Volume (vph)	25	337	5	9	361	204	4	0	12	205	1	35	
Ideal Flow (vphpl)	1900	1900	1900	1900	1900	1900	1900	1900	1900	1900	1900	1900	
Total Lost time (s)	4.0	4.0		4.0	4.0			4.0			4.0	4.0	
Lane Util. Factor	1.00	0.95		1.00	0.95			1.00			1.00	1.00	
Frt	1.00	1.00		1.00	0.95			0.90			1.00	0.85	
Flt Protected	0.95	1.00		0.95	1.00			0.99			0.95	1.00	
Satd. Flow (prot)	1770	3532		1770	3348			1653			1774	1583	
Flt Permitted	0.95	1.00		0.95	1.00			0.99			0.95	1.00	
Satd. Flow (perm)	1770	3532		1770	3348			1653			1774	1583	
Peak-hour factor, PHF	0.95	0.95	0.95	0.85	0.85	0.85	0.57	0.57	0.57	0.86	0.86	0.86	
Adj. Flow (vph)	26	355	5	11	425	240	7	0	21	238	1	41	
RTOR Reduction (vph)	0	1	0	0	78	0	0	26	0	0	0	0	
Lane Group Flow (vph)	26	359	0	11	587	0	0	2	0	0	239	41	
Turn Type	Prot	NA		Prot	NA		Split	NA		Split	NA	custom	
Protected Phases	5	2		1	6		7	7		4	4		
Permitted Phases												6	
Actuated Green, G (s)	2.1	16.6		1.0	15.5			2.7			12.8	15.5	
Effective Green, g (s)	2.1	16.6		1.0	15.5			2.7			12.8	15.5	
Actuated g/C Ratio	0.04	0.34		0.02	0.32			0.05			0.26	0.32	
Clearance Time (s)	4.0	4.0		4.0	4.0			4.0			4.0	4.0	
Vehicle Extension (s)	3.0	3.0		3.0	3.0			3.0			3.0	3.0	
Lane Grp Cap (vph)	75	1194		36	1056			90			462	499	
v/s Ratio Prot	c0.01	0.10		0.01	c0.18			c0.00			c0.13		
v/s Ratio Perm												0.03	
v/c Ratio	0.35	0.30		0.31	0.56			0.02			0.52	0.08	
Uniform Delay, d1	22.8	12.0		23.7	13.9			21.9			15.5	11.8	
Progression Factor	1.00	1.00		1.00	1.00			1.00			1.00	1.00	
Incremental Delay, d2	2.8	0.1		4.8	0.6			0.1			1.0	0.1	
Delay (s)	25.6	12.1		28.5	14.6			22.0			16.5	11.9	
Level of Service	C	B		C	B			C			B	B	
Approach Delay (s)		13.0			14.8			22.0			15.8		
Approach LOS		B			B			C			B		
<b>Intersection Summary</b>													
HCM 2000 Control Delay			14.7		HCM 2000 Level of Service						B		
HCM 2000 Volume to Capacity ratio			0.48										
Actuated Cycle Length (s)			49.1		Sum of lost time (s)					16.0			
Intersection Capacity Utilization			45.5%		ICU Level of Service					A			
Analysis Period (min)			15										

c Critical Lane Group

HCM 6th TWSC  
7: Driveway 1/Gridley Drive & Shiloh Road

Existing Project Alter. A Conditions  
Timing Plan: A.M. PEAK

Intersection												
Int Delay, s/veh	1.2											
Movement	EBL	EBT	EBR	WBL	WBT	WBR	NBL	NBT	NBR	SBL	SBT	SBR
Lane Configurations		↕	↕		↕		↕	↕			↕	
Traffic Vol, veh/h	8	286	47	0	159	0	33	0	0	1	0	16
Future Vol, veh/h	8	286	47	0	159	0	33	0	0	1	0	16
Conflicting Peds, #/hr	0	0	0	0	0	0	0	0	0	0	0	0
Sign Control	Free	Free	Free	Free	Free	Free	Stop	Stop	Stop	Stop	Stop	Stop
RT Channelized	-	-	None	-	-	None	-	-	None	-	-	None
Storage Length	-	-	150	-	-	-	0	-	-	-	-	-
Veh in Median Storage, #	-	0	-	-	0	-	-	0	-	-	0	-
Grade, %	-	0	-	-	0	-	-	0	-	-	0	-
Peak Hour Factor	91	91	91	85	85	85	100	100	100	71	71	71
Heavy Vehicles, %	2	2	2	2	2	2	2	2	2	2	2	2
Mvmt Flow	9	314	52	0	187	0	33	0	0	1	0	23

Major/Minor	Major1			Major2			Minor1			Minor2		
Conflicting Flow All	187	0	0	366	0	0	531	519	314	545	571	187
Stage 1	-	-	-	-	-	-	332	332	-	187	187	-
Stage 2	-	-	-	-	-	-	199	187	-	358	384	-
Critical Hdwy	4.12	-	-	4.12	-	-	7.12	6.52	6.22	7.12	6.52	6.22
Critical Hdwy Stg 1	-	-	-	-	-	-	6.12	5.52	-	6.12	5.52	-
Critical Hdwy Stg 2	-	-	-	-	-	-	6.12	5.52	-	6.12	5.52	-
Follow-up Hdwy	2.218	-	-	2.218	-	-	3.518	4.018	3.318	3.518	4.018	3.318
Pot Cap-1 Maneuver	1387	-	-	1193	-	-	459	461	726	449	431	855
Stage 1	-	-	-	-	-	-	681	644	-	815	745	-
Stage 2	-	-	-	-	-	-	803	745	-	660	611	-
Platoon blocked, %	-	-	-	-	-	-	-	-	-	-	-	-
Mov Cap-1 Maneuver	1387	-	-	1193	-	-	444	457	726	446	428	855
Mov Cap-2 Maneuver	-	-	-	-	-	-	444	457	-	446	428	-
Stage 1	-	-	-	-	-	-	676	639	-	808	745	-
Stage 2	-	-	-	-	-	-	782	745	-	655	606	-

Approach	EB			WB			NB			SB		
HCM Control Delay, s	0.2			0			13.8			9.6		
HCM LOS							B			A		

Minor Lane/Major Mvmt	NBLn1	NBLn2	EBL	EBT	EBR	WBL	WBT	WBR	SBLn1
Capacity (veh/h)	444	-	1387	-	-	1193	-	-	811
HCM Lane V/C Ratio	0.074	-	0.006	-	-	-	-	-	0.03
HCM Control Delay (s)	13.8	0	7.6	0	-	0	-	-	9.6
HCM Lane LOS	B	A	A	A	-	A	-	-	A
HCM 95th %tile Q(veh)	0.2	-	0	-	-	0	-	-	0.1



HCM 6th TWSC  
8: Old Redwood Hwy & Driveway 2

Existing Project Alter. A Conditions  
Timing Plan: A.M. PEAK

Intersection												
Int Delay, s/veh	1.5											
Movement	EBL	EBT	EBR	WBL	WBT	WBR	NBL	NBT	NBR	SBL	SBT	SBR
Lane Configurations		↕		↕	↕			↕	↕	↕	↕	
Traffic Vol, veh/h	1	0	0	19	0	31	0	217	28	45	316	0
Future Vol, veh/h	1	0	0	19	0	31	0	217	28	45	316	0
Conflicting Peds, #/hr	0	0	0	0	0	0	0	0	1	1	0	0
Sign Control	Stop	Stop	Stop	Stop	Stop	Stop	Free	Free	Free	Free	Free	Free
RT Channelized	-	-	None	-	-	None	-	-	None	-	-	None
Storage Length	-	-	-	0	-	-	-	-	100	50	-	-
Veh in Median Storage, #	-	0	-	-	0	-	-	0	-	-	0	-
Grade, %	-	0	-	-	0	-	-	0	-	-	0	-
Peak Hour Factor	25	25	25	100	100	100	99	99	99	90	90	90
Heavy Vehicles, %	2	2	2	2	2	2	2	2	2	2	2	2
Mvmt Flow	4	0	0	19	0	31	0	219	28	50	351	0

Major/Minor	Minor2		Minor1		Major1		Major2					
Conflicting Flow All	700	699	351	671	671	220	351	0	0	248	0	0
Stage 1	451	451	-	220	220	-	-	-	-	-	-	-
Stage 2	249	248	-	451	451	-	-	-	-	-	-	-
Critical Hdwy	7.12	6.52	6.22	7.12	6.52	6.22	4.12	-	-	4.12	-	-
Critical Hdwy Stg 1	6.12	5.52	-	6.12	5.52	-	-	-	-	-	-	-
Critical Hdwy Stg 2	6.12	5.52	-	6.12	5.52	-	-	-	-	-	-	-
Follow-up Hdwy	3.518	4.018	3.318	3.518	4.018	3.318	2.218	-	-	2.218	-	-
Pot Cap-1 Maneuver	354	364	692	370	378	820	1208	-	-	1318	-	-
Stage 1	588	571	-	782	721	-	-	-	-	-	-	-
Stage 2	755	701	-	588	571	-	-	-	-	-	-	-
Platoon blocked, %								-	-	-	-	-
Mov Cap-1 Maneuver	331	350	692	359	363	819	1208	-	-	1317	-	-
Mov Cap-2 Maneuver	331	350	-	359	363	-	-	-	-	-	-	-
Stage 1	588	549	-	781	720	-	-	-	-	-	-	-
Stage 2	726	700	-	566	549	-	-	-	-	-	-	-

Approach	EB	WB	NB	SB
HCM Control Delay, s	16	11.9	0	1
HCM LOS	C	B		

Minor Lane/Major Mvmt	NBL	NBT	NBR	EBLn1	WBLn1	WBLn2	SBL	SBT	SBR
Capacity (veh/h)	1208	-	-	331	359	819	1317	-	-
HCM Lane V/C Ratio	-	-	-	0.012	0.053	0.038	0.038	-	-
HCM Control Delay (s)	0	-	-	16	15.6	9.6	7.8	-	-
HCM Lane LOS	A	-	-	C	C	A	A	-	-
HCM 95th %tile Q(veh)	0	-	-	0	0.2	0.1	0.1	-	-

Intersection						
Int Delay, s/veh	2.5					
Movement	EBT	EBR	WBL	WBT	NBL	NBR
Lane Configurations	↑	↗		↖	↖	↗
Traffic Vol, veh/h	140	145	14	52	101	10
Future Vol, veh/h	140	145	14	52	101	10
Conflicting Peds, #/hr	0	0	0	0	0	0
Sign Control	Free	Free	Free	Free	Stop	Stop
RT Channelized	-	None	-	None	-	None
Storage Length	-	200	-	-	0	0
Veh in Median Storage, #	0	-	-	0	0	-
Grade, %	0	-	-	0	0	-
Peak Hour Factor	85	85	81	81	100	100
Heavy Vehicles, %	2	2	2	2	2	2
Mvmt Flow	165	171	17	64	101	10

Major/Minor	Major1	Major2	Minor1		
Conflicting Flow All	0	0	336	0	263
Stage 1	-	-	-	-	165
Stage 2	-	-	-	-	98
Critical Hdwy	-	-	4.12	-	6.42
Critical Hdwy Stg 1	-	-	-	-	5.42
Critical Hdwy Stg 2	-	-	-	-	5.42
Follow-up Hdwy	-	-	2.218	-	3.518
Pot Cap-1 Maneuver	-	-	1223	-	726
Stage 1	-	-	-	-	864
Stage 2	-	-	-	-	926
Platoon blocked, %	-	-	-	-	-
Mov Cap-1 Maneuver	-	-	1223	-	716
Mov Cap-2 Maneuver	-	-	-	-	716
Stage 1	-	-	-	-	864
Stage 2	-	-	-	-	913

Approach	EB	WB	NB
HCM Control Delay, s	0	1.7	10.7
HCM LOS			B

Minor Lane/Major Mvmt	NBLn1	NBLn2	EBT	EBR	WBL	WBT
Capacity (veh/h)	716	879	-	-	1223	-
HCM Lane V/C Ratio	0.141	0.011	-	-	0.014	-
HCM Control Delay (s)	10.9	9.1	-	-	8	0
HCM Lane LOS	B	A	-	-	A	A
HCM 95th %tile Q(veh)	0.5	0	-	-	0	-

HCM 6th Signalized Intersection Summary  
 10: US 101 NB Off Ramp/Lakewood Drive & Old Redwood Highway

Existing Project Alter. A Conditions  
 Timing Plan: A.M. PEAK



Movement	EBL	EBT	EBR	WBL	WBT	WBR	NBL	NBT	NBR	SBL	SBT	SBR
Lane Configurations	↔↔	↑			↑↑		↔	↔↔		↔↔		↔
Traffic Volume (veh/h)	152	177	0	0	459	149	227	221	79	118	0	534
Future Volume (veh/h)	152	177	0	0	459	149	227	221	79	118	0	534
Initial Q (Qb), veh	0	0	0	0	0	0	0	0	0	0	0	0
Ped-Bike Adj(A_pbT)	1.00		1.00	1.00		0.99	1.00		1.00	1.00		1.00
Parking Bus, Adj	1.00	1.00	1.00	1.00	1.00	1.00	1.00	1.00	1.00	1.00	1.00	1.00
Work Zone On Approach		No			No			No			No	
Adj Sat Flow, veh/h/ln	1870	1870	0	0	1870	1870	1870	1870	1870	1870	0	1870
Adj Flow Rate, veh/h	179	208	0	0	553	180	195	325	88	133	0	0
Peak Hour Factor	0.85	0.85	0.85	0.83	0.83	0.83	0.90	0.90	0.90	0.89	0.89	0.89
Percent Heavy Veh, %	2	2	0	0	2	2	2	2	2	2	0	2
Cap, veh/h	373	1215	0	0	1254	407	342	546	145	0	0	
Arrive On Green	0.11	0.65	0.00	0.00	0.48	0.48	0.19	0.19	0.19	0.00	0.00	0.00
Sat Flow, veh/h	3456	1870	0	0	2722	852	1781	2844	758		0	
Grp Volume(v), veh/h	179	208	0	0	373	360	195	212	201		0.0	
Grp Sat Flow(s),veh/h/ln	1728	1870	0	0	1777	1704	1781	1870	1731			
Q Serve(g_s), s	3.0	2.7	0.0	0.0	8.6	8.7	6.1	6.4	6.6			
Cycle Q Clear(g_c), s	3.0	2.7	0.0	0.0	8.6	8.7	6.1	6.4	6.6			
Prop In Lane	1.00		0.00	0.00		0.50	1.00		0.44			
Lane Grp Cap(c), veh/h	373	1215	0	0	848	813	342	359	332			
V/C Ratio(X)	0.48	0.17	0.00	0.00	0.44	0.44	0.57	0.59	0.61			
Avail Cap(c_a), veh/h	503	1215	0	0	848	813	835	877	811			
HCM Platoon Ratio	1.00	1.00	1.00	1.00	1.00	1.00	1.00	1.00	1.00			
Upstream Filter(I)	1.00	1.00	0.00	0.00	1.00	1.00	1.00	1.00	1.00			
Uniform Delay (d), s/veh	26.0	4.3	0.0	0.0	10.7	10.7	22.7	22.8	22.9			
Incr Delay (d2), s/veh	1.0	0.3	0.0	0.0	1.7	1.7	1.5	1.5	1.8			
Initial Q Delay(d3),s/veh	0.0	0.0	0.0	0.0	0.0	0.0	0.0	0.0	0.0			
%ile BackOfQ(50%),veh/ln	1.2	0.8	0.0	0.0	3.2	3.1	2.5	2.8	2.7			
Unsig. Movement Delay, s/veh												
LnGrp Delay(d),s/veh	26.9	4.6	0.0	0.0	12.4	12.5	24.2	24.3	24.6			
LnGrp LOS	C	A	A	A	B	B	C	C	C			
Approach Vol, veh/h		387			733			608				
Approach Delay, s/veh		14.9			12.4			24.4				
Approach LOS		B			B			C				
Timer - Assigned Phs		2			5	6		8				
Phs Duration (G+Y+Rc), s		45.3			10.7	34.6		16.6				
Change Period (Y+Rc), s		5.1			4.0	5.1		4.7				
Max Green Setting (Gmax), s		40.2			9.0	27.2		29.0				
Max Q Clear Time (g_c+I1), s		4.7			5.0	10.7		8.6				
Green Ext Time (p_c), s		1.2			0.2	4.2		3.0				

Intersection Summary

HCM 6th Ctrl Delay	17.2
HCM 6th LOS	B

Notes

User approved volume balancing among the lanes for turning movement.  
 Unsignalized Delay for [SBR] is excluded from calculations of the approach delay and intersection delay.

HCM 6th Signalized Intersection Summary

Existing Project Alter. A Conditions

12: US 101 SB On Ramp/US 101 SB Off Ramp & Old Redwood Highway

Timing Plan: A.M. PEAK



Movement	EBL	EBT	EBR	WBL	WBT	WBR	NBL	NBT	NBR	SBL	SBT	SBR
Lane Configurations		↑↑	↗	↘	↑↑					↘	↕	
Traffic Volume (veh/h)	0	298	296	513	504	0	0	0	0	120	1	65
Future Volume (veh/h)	0	298	296	513	504	0	0	0	0	120	1	65
Initial Q (Qb), veh	0	0	0	0	0	0				0	0	0
Ped-Bike Adj(A_pbT)	1.00		0.98	1.00		1.00				1.00		1.00
Parking Bus, Adj	1.00	1.00	1.00	1.00	1.00	1.00				1.00	1.00	1.00
Work Zone On Approach		No			No						No	
Adj Sat Flow, veh/h/ln	0	1870	1870	1870	1870	0				1870	1870	1870
Adj Flow Rate, veh/h	0	324	322	576	566	0				114	48	0
Peak Hour Factor	0.92	0.92	0.92	0.89	0.89	0.89				0.81	0.81	0.81
Percent Heavy Veh, %	0	2	2	2	2	0				2	2	2
Cap, veh/h	0	1281	563	613	2683	0				217	228	
Arrive On Green	0.00	0.36	0.36	0.34	0.76	0.00				0.12	0.12	0.00
Sat Flow, veh/h	0	3647	1560	1781	3647	0				1781	1870	0
Grp Volume(v), veh/h	0	324	322	576	566	0				114	48	0
Grp Sat Flow(s),veh/h/ln	0	1777	1560	1781	1777	0				1781	1870	0
Q Serve(g_s), s	0.0	5.1	13.3	25.0	3.7	0.0				4.8	1.8	0.0
Cycle Q Clear(g_c), s	0.0	5.1	13.3	25.0	3.7	0.0				4.8	1.8	0.0
Prop In Lane	0.00		1.00	1.00		0.00				1.00		0.00
Lane Grp Cap(c), veh/h	0	1281	563	613	2683	0				217	228	
V/C Ratio(X)	0.00	0.25	0.57	0.94	0.21	0.00				0.52	0.21	
Avail Cap(c_a), veh/h	0	1281	563	648	2683	0				223	235	
HCM Platoon Ratio	1.00	1.00	1.00	1.00	1.00	1.00				1.00	1.00	1.00
Upstream Filter(I)	0.00	1.00	1.00	1.00	1.00	0.00				1.00	1.00	0.00
Uniform Delay (d), s/veh	0.0	17.9	20.5	25.3	2.8	0.0				32.8	31.5	0.0
Incr Delay (d2), s/veh	0.0	0.5	4.2	21.1	0.2	0.0				2.1	0.5	0.0
Initial Q Delay(d3),s/veh	0.0	0.0	0.0	0.0	0.0	0.0				0.0	0.0	0.0
%ile BackOfQ(50%),veh/ln	0.0	2.1	5.1	13.3	0.8	0.0				2.1	0.8	0.0
Unsig. Movement Delay, s/veh												
LnGrp Delay(d),s/veh	0.0	18.4	24.7	46.4	3.0	0.0				34.9	32.0	0.0
LnGrp LOS	A	B	C	D	A	A				C	C	
Approach Vol, veh/h		646			1142							162
Approach Delay, s/veh		21.6			24.9							34.1
Approach LOS		C			C							C
Timer - Assigned Phs		2			5	6		8				
Phs Duration (G+Y+Rc), s		65.3			31.5	33.8		14.4				
Change Period (Y+Rc), s		5.1			4.0	5.1		4.7				
Max Green Setting (Gmax), s		60.2			29.0	27.2		10.0				
Max Q Clear Time (g_c+I1), s		5.7			27.0	15.3		6.8				
Green Ext Time (p_c), s		4.2			0.5	2.6		0.1				

Intersection Summary























HCM 6th Ctrl Delay	24.6
HCM 6th LOS	C

Notes

- User approved volume balancing among the lanes for turning movement.
- User approved ignoring U-Turning movement.
- Unsignalized Delay for [SBR] is excluded from calculations of the approach delay and intersection delay.

HCM 6th Signalized Intersection Summary  
 1: Old Redwood Hwy & Shiloh Road

Existing Project Alter. A Conditions  
 Timing Plan: P.M. Peak

												
Movement	EBL	EBT	EBR	WBL	WBT	WBR	NBL	NBT	NBR	SBL	SBT	SBR
Lane Configurations												
Traffic Volume (veh/h)	241	516	260	37	381	55	209	347	21	80	247	146
Future Volume (veh/h)	241	516	260	37	381	55	209	347	21	80	247	146
Initial Q (Qb), veh	0	0	0	0	0	0	0	0	0	0	0	0
Ped-Bike Adj(A_pbT)	1.00		1.00	1.00		1.00	1.00		0.97	1.00		0.97
Parking Bus, Adj	1.00	1.00	1.00	1.00	1.00	1.00	1.00	1.00	1.00	1.00	1.00	1.00
Work Zone On Approach		No			No			No			No	
Adj Sat Flow, veh/h/ln	1870	1870	1870	1870	1870	1870	1870	1870	1870	1870	1870	1870
Adj Flow Rate, veh/h	248	532	268	41	419	60	225	373	23	86	266	157
Peak Hour Factor	0.97	0.97	0.97	0.91	0.91	0.91	0.93	0.93	0.93	0.93	0.93	0.93
Percent Heavy Veh, %	2	2	2	2	2	2	2	2	2	2	2	2
Cap, veh/h	483	507	429	46	465	434	229	469	387	95	327	269
Arrive On Green	0.27	0.27	0.27	0.27	0.27	0.27	0.13	0.25	0.25	0.05	0.17	0.17
Sat Flow, veh/h	1781	1870	1582	166	1696	1582	1781	1870	1543	1781	1870	1539
Grp Volume(v), veh/h	248	532	268	460	0	60	225	373	23	86	266	157
Grp Sat Flow(s),veh/h/ln	1781	1870	1582	1862	0	1582	1781	1870	1543	1781	1870	1539
Q Serve(g_s), s	13.3	30.5	16.7	26.8	0.0	3.2	14.2	21.0	1.3	5.4	15.4	10.6
Cycle Q Clear(g_c), s	13.3	30.5	16.7	26.8	0.0	3.2	14.2	21.0	1.3	5.4	15.4	10.6
Prop In Lane	1.00		1.00	0.09		1.00	1.00		1.00	1.00		1.00
Lane Grp Cap(c), veh/h	483	507	429	511	0	434	229	469	387	95	327	269
V/C Ratio(X)	0.51	1.05	0.63	0.90	0.00	0.14	0.98	0.80	0.06	0.91	0.81	0.58
Avail Cap(c_a), veh/h	483	507	429	628	0	534	229	723	596	95	581	478
HCM Platoon Ratio	1.00	1.00	1.00	1.00	1.00	1.00	1.00	1.00	1.00	1.00	1.00	1.00
Upstream Filter(I)	1.00	1.00	1.00	1.00	0.00	1.00	1.00	1.00	1.00	1.00	1.00	1.00
Uniform Delay (d), s/veh	34.8	41.0	36.0	39.4	0.0	30.8	48.9	39.5	32.1	53.0	44.7	42.7
Incr Delay (d2), s/veh	0.9	53.7	2.8	14.1	0.0	0.1	53.8	3.5	0.1	62.7	4.9	2.0
Initial Q Delay(d3),s/veh	0.0	0.0	0.0	0.0	0.0	0.0	0.0	0.0	0.0	0.0	0.0	0.0
%ile BackOfQ(50%),veh/ln	5.7	21.1	6.5	13.8	0.0	1.2	9.5	9.7	0.5	4.0	7.4	4.1
Unsig. Movement Delay, s/veh												
LnGrp Delay(d),s/veh	35.7	94.8	38.9	53.4	0.0	31.0	102.7	43.0	32.2	115.7	49.5	44.7
LnGrp LOS	D	F	D	D	A	C	F	D	C	F	D	D
Approach Vol, veh/h		1048			520			621			509	
Approach Delay, s/veh		66.5			50.8			64.2			59.2	
Approach LOS		E			D			E			E	
Timer - Assigned Phs		2	3	4		6	7	8				
Phs Duration (G+Y+Rc), s		35.0	18.0	24.2		35.4	9.5	32.7				
Change Period (Y+Rc), s		4.5	3.5	4.5		4.5	3.5	4.5				
Max Green Setting (Gmax), s		30.5	14.5	35.0		38.0	6.0	43.5				
Max Q Clear Time (g_c+I1), s		32.5	16.2	17.4		28.8	7.4	23.0				
Green Ext Time (p_c), s		0.0	0.0	1.8		2.0	0.0	2.0				
<b>Intersection Summary</b>												
HCM 6th Ctrl Delay			61.6									
HCM 6th LOS			E									

# HCM Signalized Intersection Capacity Analysis

## 2: Shiloh Road & Hembree Ln

Existing Project Alter. A Conditions  
Timing Plan: P.M. Peak

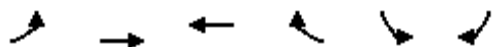

Movement	EBL	EBT	WBT	WBR	SBL	SBR
Lane Configurations	↔↔	↑	↕↔		↔	↔
Traffic Volume (vph)	615	866	620	141	170	491
Future Volume (vph)	615	866	620	141	170	491
Ideal Flow (vphpl)	1900	1900	1900	1900	1900	1900
Total Lost time (s)	4.0	4.0	4.0		4.0	4.0
Lane Util. Factor	0.97	1.00	0.95		1.00	1.00
Frbp, ped/bikes	1.00	1.00	1.00		1.00	1.00
Flpb, ped/bikes	1.00	1.00	1.00		1.00	1.00
Frt	1.00	1.00	0.97		1.00	0.85
Flt Protected	0.95	1.00	1.00		0.95	1.00
Satd. Flow (prot)	3433	1863	3433		1770	1583
Flt Permitted	0.95	1.00	1.00		0.95	1.00
Satd. Flow (perm)	3433	1863	3433		1770	1583
Peak-hour factor, PHF	0.94	0.94	0.87	0.87	0.95	0.95
Adj. Flow (vph)	654	921	713	162	179	517
RTOR Reduction (vph)	0	0	25	0	0	70
Lane Group Flow (vph)	654	921	850	0	179	447
Confl. Peds. (#/hr)	2			2		
Turn Type	Prot	NA	NA		Perm	pm+ov
Protected Phases	5	2	6			5
Permitted Phases					4	4 5
Actuated Green, G (s)	19.3	47.4	24.1		11.5	30.8
Effective Green, g (s)	19.3	47.4	24.1		11.5	30.8
Actuated g/C Ratio	0.29	0.71	0.36		0.17	0.46
Clearance Time (s)	4.0	4.0	4.0		4.0	4.0
Vehicle Extension (s)	3.0	3.0	3.0		3.0	3.0
Lane Grp Cap (vph)	990	1319	1236		304	823
v/s Ratio Prot	0.19	c0.49	0.25			c0.16
v/s Ratio Perm					0.10	0.13
v/c Ratio	0.66	0.70	0.69		0.59	0.54
Uniform Delay, d1	20.9	5.6	18.2		25.5	13.0
Progression Factor	1.00	1.00	1.00		1.00	1.00
Incremental Delay, d2	1.7	1.6	1.6		2.9	0.7
Delay (s)	22.6	7.3	19.8		28.4	13.7
Level of Service	C	A	B		C	B
Approach Delay (s)		13.6	19.8		17.5	
Approach LOS		B	B		B	
<b>Intersection Summary</b>						
HCM 2000 Control Delay			16.2		HCM 2000 Level of Service	B
HCM 2000 Volume to Capacity ratio			0.73			
Actuated Cycle Length (s)			66.9		Sum of lost time (s)	12.0
Intersection Capacity Utilization			61.7%		ICU Level of Service	B
Analysis Period (min)			15			
c Critical Lane Group						

HCM 6th Signalized Intersection Summary  
 3: US 101 NB Off-Ramp & Shiloh Road

Existing Project Alter. A Conditions  
 Timing Plan: P.M. Peak



Movement	EBT	EBR	WBL	WBT	NBL	NBR
Lane Configurations	↑↑			↑	↘	↗↗
Traffic Volume (veh/h)	561	0	0	762	526	925
Future Volume (veh/h)	561	0	0	762	526	925
Initial Q (Qb), veh	0	0	0	0	0	0
Ped-Bike Adj(A_pbT)		1.00	1.00		1.00	1.00
Parking Bus, Adj	1.00	1.00	1.00	1.00	1.00	1.00
Work Zone On Approach	No			No	No	
Adj Sat Flow, veh/h/ln	1870	0	0	1870	1870	1870
Adj Flow Rate, veh/h	597	0	0	786	584	1028
Peak Hour Factor	0.94	0.94	0.97	0.97	0.90	0.90
Percent Heavy Veh, %	2	0	0	2	2	2
Cap, veh/h	1623	0	0	854	754	1181
Arrive On Green	0.46	0.00	0.00	0.46	0.42	0.42
Sat Flow, veh/h	3741	0	0	1870	1781	2790
Grp Volume(v), veh/h	597	0	0	786	584	1028
Grp Sat Flow(s),veh/h/ln	1777	0	0	1870	1781	1395
Q Serve(g_s), s	7.3	0.0	0.0	26.2	18.7	22.4
Cycle Q Clear(g_c), s	7.3	0.0	0.0	26.2	18.7	22.4
Prop In Lane		0.00	0.00		1.00	1.00
Lane Grp Cap(c), veh/h	1623	0	0	854	754	1181
V/C Ratio(X)	0.37	0.00	0.00	0.92	0.77	0.87
Avail Cap(c_a), veh/h	1761	0	0	927	829	1299
HCM Platoon Ratio	1.00	1.00	1.00	1.00	1.00	1.00
Upstream Filter(I)	1.00	0.00	0.00	1.00	1.00	1.00
Uniform Delay (d), s/veh	11.8	0.0	0.0	17.0	16.5	17.5
Incr Delay (d2), s/veh	0.1	0.0	0.0	13.5	4.2	6.2
Initial Q Delay(d3),s/veh	0.0	0.0	0.0	0.0	0.0	0.0
%ile BackOfQ(50%),veh/ln	2.4	0.0	0.0	12.3	7.6	7.3
Unsig. Movement Delay, s/veh						
LnGrp Delay(d),s/veh	12.0	0.0	0.0	30.4	20.7	23.8
LnGrp LOS	B	A	A	C	C	C
Approach Vol, veh/h	597			786	1612	
Approach Delay, s/veh	12.0			30.4	22.7	
Approach LOS	B			C	C	
Timer - Assigned Phs		2			6	8
Phs Duration (G+Y+Rc), s		34.4			34.4	32.2
Change Period (Y+Rc), s		4.0			4.0	4.0
Max Green Setting (Gmax), s		33.0			33.0	31.0
Max Q Clear Time (g_c+I1), s		9.3			28.2	24.4
Green Ext Time (p_c), s		3.9			2.2	3.8
<b>Intersection Summary</b>						
HCM 6th Ctrl Delay			22.6			
HCM 6th LOS			C			

HCM Signalized Intersection Capacity Analysis  
4: Shiloh Road & US 101 SB Off-Ramp

Existing Project Alter. A Conditions  
Timing Plan: P.M. Peak



Movement	EBL	EBT	WBT	WBR	SBL	SBR
Lane Configurations		↑	↑		↘	↗
Traffic Volume (vph)	0	458	640	0	299	110
Future Volume (vph)	0	458	640	0	299	110
Ideal Flow (vphpl)	1900	1900	1900	1900	1900	1900
Total Lost time (s)		4.0	4.0		4.0	4.0
Lane Util. Factor		1.00	1.00		1.00	1.00
Frbp, ped/bikes		1.00	1.00		1.00	0.98
Flpb, ped/bikes		1.00	1.00		1.00	1.00
Frt		1.00	1.00		1.00	0.85
Flt Protected		1.00	1.00		0.95	1.00
Satd. Flow (prot)		1863	1863		1770	1549
Flt Permitted		1.00	1.00		0.95	1.00
Satd. Flow (perm)		1863	1863		1770	1549
Peak-hour factor, PHF	0.89	0.89	0.96	0.96	0.93	0.93
Adj. Flow (vph)	0	515	667	0	322	118
RTOR Reduction (vph)	0	0	0	0	0	77
Lane Group Flow (vph)	0	515	667	0	322	41
Confl. Peds. (#/hr)						1
Turn Type		NA	NA		Perm	Perm
Protected Phases		2	6			
Permitted Phases					4	4
Actuated Green, G (s)		22.2	22.2		16.1	16.1
Effective Green, g (s)		22.2	22.2		16.1	16.1
Actuated g/C Ratio		0.48	0.48		0.35	0.35
Clearance Time (s)		4.0	4.0		4.0	4.0
Vehicle Extension (s)		3.0	3.0		3.0	3.0
Lane Grp Cap (vph)		893	893		615	538
v/s Ratio Prot		0.28	c0.36			
v/s Ratio Perm					c0.18	0.03
v/c Ratio		0.58	0.75		0.52	0.08
Uniform Delay, d1		8.7	9.8		12.0	10.1
Progression Factor		1.00	1.00		1.00	1.00
Incremental Delay, d2		0.9	3.4		0.8	0.1
Delay (s)		9.6	13.2		12.8	10.2
Level of Service		A	B		B	B
Approach Delay (s)		9.6	13.2		12.1	
Approach LOS		A	B		B	
<b>Intersection Summary</b>						
HCM 2000 Control Delay			11.8		HCM 2000 Level of Service	B
HCM 2000 Volume to Capacity ratio			0.65			
Actuated Cycle Length (s)			46.3		Sum of lost time (s)	8.0
Intersection Capacity Utilization			120.5%		ICU Level of Service	H
Analysis Period (min)			15			
c Critical Lane Group						



Intersection						
Int Delay, s/veh	2.5					
Movement	EBT	EBR	WBL	WBT	NBL	NBR
Lane Configurations	↑↑		↘	↑	↘	↘
Traffic Vol, veh/h	886	28	79	676	15	149
Future Vol, veh/h	886	28	79	676	15	149
Conflicting Peds, #/hr	0	0	0	0	0	0
Sign Control	Free	Free	Free	Free	Stop	Stop
RT Channelized	-	None	-	None	-	None
Storage Length	-	-	68	-	0	0
Veh in Median Storage, #	0	-	-	0	0	-
Grade, %	0	-	-	0	0	-
Peak Hour Factor	89	89	92	92	89	89
Heavy Vehicles, %	2	2	2	2	2	2
Mvmt Flow	996	31	86	735	17	167

























Major/Minor	Major1	Major2	Minor1	Minor2	Minor3
Conflicting Flow All	0	0	1027	0	1919
Stage 1	-	-	-	-	1012
Stage 2	-	-	-	-	907
Critical Hdwy	-	-	4.13	-	6.63
Critical Hdwy Stg 1	-	-	-	-	5.83
Critical Hdwy Stg 2	-	-	-	-	5.43
Follow-up Hdwy	-	-	2.219	-	3.519
Pot Cap-1 Maneuver	-	-	674	-	66
Stage 1	-	-	-	-	313
Stage 2	-	-	-	-	393
Platoon blocked, %	-	-	-	-	-
Mov Cap-1 Maneuver	-	-	674	-	58
Mov Cap-2 Maneuver	-	-	-	-	58
Stage 1	-	-	-	-	313
Stage 2	-	-	-	-	343

Approach	EB	WB	NB
HCM Control Delay, s	0	1.2	22.5
HCM LOS			C

Minor Lane/Major Mvmt	NBLn1	NBLn2	EBT	EBR	WBL	WBT
Capacity (veh/h)	58	506	-	-	674	-
HCM Lane V/C Ratio	0.291	0.331	-	-	0.127	-
HCM Control Delay (s)	90.7	15.6	-	-	11.1	-
HCM Lane LOS	F	C	-	-	B	-
HCM 95th %tile Q(veh)	1	1.4	-	-	0.4	-

HCM Signalized Intersection Capacity Analysis  
6: Conde Lane & Shiloh Road

Existing Project Alter. A Conditions  
Timing Plan: P.M. Peak

												
Movement	EBL	EBT	EBR	WBL	WBT	WBR	NBL	NBT	NBR	SBL	SBT	SBR
Lane Configurations		 			 			 			 	 
Traffic Volume (vph)	69	505	2	7	481	289	5	3	17	297	0	39
Future Volume (vph)	69	505	2	7	481	289	5	3	17	297	0	39
Ideal Flow (vphp)	1900	1900	1900	1900	1900	1900	1900	1900	1900	1900	1900	1900
Total Lost time (s)	4.0	4.0		4.0	4.0			4.0			4.0	4.0
Lane Util. Factor	1.00	0.95		1.00	0.95			1.00			1.00	1.00
Frbp, ped/bikes	1.00	1.00		1.00	0.99			1.00			1.00	1.00
Flpb, ped/bikes	1.00	1.00		1.00	1.00			1.00			1.00	1.00
Frt	1.00	1.00		1.00	0.94			0.91			1.00	0.85
Flt Protected	0.95	1.00		0.95	1.00			0.99			0.95	1.00
Satd. Flow (prot)	1770	3537		1770	3313			1676			1770	1583
Flt Permitted	0.95	1.00		0.95	1.00			0.99			0.95	1.00
Satd. Flow (perm)	1770	3537		1770	3313			1676			1770	1583
Peak-hour factor, PHF	0.88	0.88	0.88	0.80	0.80	0.80	0.63	0.63	0.63	0.88	0.88	0.88
Adj. Flow (vph)	78	574	2	9	601	361	8	5	27	338	0	44
RTOR Reduction (vph)	0	0	0	0	78	0	0	25	0	0	0	0
Lane Group Flow (vph)	78	576	0	9	884	0	0	15	0	0	338	44
Confl. Peds. (#/hr)	1					1						
Turn Type	Prot	NA		Prot	NA		Split	NA		Split	NA	custom
Protected Phases	5	2		1	6		7	7		4	4	
Permitted Phases												6
Actuated Green, G (s)	6.4	31.7		1.2	26.5			4.9			12.4	26.5
Effective Green, g (s)	6.4	31.7		1.2	26.5			4.9			12.4	26.5
Actuated g/C Ratio	0.10	0.48		0.02	0.40			0.07			0.19	0.40
Clearance Time (s)	4.0	4.0		4.0	4.0			4.0			4.0	4.0
Vehicle Extension (s)	3.0	3.0		3.0	3.0			3.0			3.0	3.0
Lane Grp Cap (vph)	171	1693		32	1326			124			331	633
v/s Ratio Prot	c0.04	0.16		0.01	c0.27			c0.01			c0.19	
v/s Ratio Perm												0.03
v/c Ratio	0.46	0.34		0.28	0.67			0.12			1.02	0.07
Uniform Delay, d1	28.3	10.7		32.1	16.2			28.6			26.9	12.2
Progression Factor	1.00	1.00		1.00	1.00			1.00			1.00	1.00
Incremental Delay, d2	1.9	0.1		4.8	1.3			0.4			55.0	0.0
Delay (s)	30.2	10.9		36.8	17.5			29.1			81.9	12.3
Level of Service	C	B		D	B			C			F	B
Approach Delay (s)		13.2			17.7			29.1			73.9	
Approach LOS		B			B			C			E	
<b>Intersection Summary</b>												
HCM 2000 Control Delay			27.0			HCM 2000 Level of Service				C		
HCM 2000 Volume to Capacity ratio			0.67									
Actuated Cycle Length (s)			66.2			Sum of lost time (s)			16.0			
Intersection Capacity Utilization			62.4%			ICU Level of Service				B		
Analysis Period (min)			15									
c	Critical Lane Group											

HCM 6th TWSC  
7: Driveway 1/Gridley Drive & Shiloh Road

Existing Project Alter. A Conditions  
Timing Plan: P.M. Peak

Intersection												
Int Delay, s/veh	3.1											
Movement	EBL	EBT	EBR	WBL	WBT	WBR	NBL	NBT	NBR	SBL	SBT	SBR
Lane Configurations		↕	↗		↕		↗	↘			↕	
Traffic Vol, veh/h	17	472	121	0	383	0	84	0	0	0	0	14
Future Vol, veh/h	17	472	121	0	383	0	84	0	0	0	0	14
Conflicting Peds, #/hr	1	0	0	0	0	0	0	0	0	0	0	0
Sign Control	Free	Free	Free	Free	Free	Free	Stop	Stop	Stop	Stop	Stop	Stop
RT Channelized	-	-	None	-	-	None	-	-	None	-	-	None
Storage Length	-	-	150	-	-	-	0	-	-	-	-	-
Veh in Median Storage, #	-	0	-	-	0	-	-	0	-	-	0	-
Grade, %	-	0	-	-	0	-	-	0	-	-	0	-
Peak Hour Factor	94	94	94	69	69	69	100	100	100	58	58	58
Heavy Vehicles, %	2	2	2	2	2	2	2	2	2	2	2	2
Mvmt Flow	18	502	129	0	555	0	84	0	0	0	0	24

Major/Minor	Major1			Major2			Minor1			Minor2		
Conflicting Flow All	556	0	0	631	0	0	1105	1094	502	1159	1223	556
Stage 1	-	-	-	-	-	-	538	538	-	556	556	-
Stage 2	-	-	-	-	-	-	567	556	-	603	667	-
Critical Hdwy	4.12	-	-	4.12	-	-	7.12	6.52	6.22	7.12	6.52	6.22
Critical Hdwy Stg 1	-	-	-	-	-	-	6.12	5.52	-	6.12	5.52	-
Critical Hdwy Stg 2	-	-	-	-	-	-	6.12	5.52	-	6.12	5.52	-
Follow-up Hdwy	2.218	-	-	2.218	-	-	3.518	4.018	3.318	3.518	4.018	3.318
Pot Cap-1 Maneuver	1015	-	-	951	-	-	188	214	569	173	179	531
Stage 1	-	-	-	-	-	-	527	522	-	515	513	-
Stage 2	-	-	-	-	-	-	508	513	-	486	457	-
Platoon blocked, %		-	-	-	-	-						
Mov Cap-1 Maneuver	1014	-	-	951	-	-	176	208	569	169	174	530
Mov Cap-2 Maneuver	-	-	-	-	-	-	176	208	-	169	174	-
Stage 1	-	-	-	-	-	-	512	507	-	500	512	-
Stage 2	-	-	-	-	-	-	485	512	-	472	444	-

Approach	EB	WB	NB	SB
HCM Control Delay, s	0.2	0	42.8	12.1
HCM LOS			E	B

Minor Lane/Major Mvmt	NBLn1	NBLn2	EBL	EBT	EBR	WBL	WBT	WBR	SBLn1
Capacity (veh/h)	176	-	1014	-	-	951	-	-	530
HCM Lane V/C Ratio	0.477	-	0.018	-	-	-	-	-	0.046
HCM Control Delay (s)	42.8	0	8.6	0	-	0	-	-	12.1
HCM Lane LOS	E	A	A	A	-	A	-	-	B
HCM 95th %tile Q(veh)	2.3	-	0.1	-	-	0	-	-	0.1

HCM 6th TWSC  
8: Old Redwood Hwy & Driveway 2

Existing Project Alter. A Conditions  
Timing Plan: P.M. Peak

Intersection												
Int Delay, s/veh	3.6											
Movement	EBL	EBT	EBR	WBL	WBT	WBR	NBL	NBT	NBR	SBL	SBT	SBR
Lane Configurations		↕		↕	↕			↕	↕	↕	↕	
Traffic Vol, veh/h	3	0	0	49	0	79	0	505	71	114	427	0
Future Vol, veh/h	3	0	0	49	0	79	0	505	71	114	427	0
Conflicting Peds, #/hr	0	0	0	0	0	0	0	0	0	0	0	0
Sign Control	Stop	Stop	Stop	Stop	Stop	Stop	Free	Free	Free	Free	Free	Free
RT Channelized	-	-	None	-	-	None	-	-	None	-	-	None
Storage Length	-	-	-	0	-	-	-	-	100	50	-	-
Veh in Median Storage, #	-	0	-	-	0	-	-	0	-	-	0	-
Grade, %	-	0	-	-	0	-	-	0	-	-	0	-
Peak Hour Factor	38	38	38	100	100	100	91	91	91	94	94	94
Heavy Vehicles, %	2	2	2	2	2	2	2	2	2	2	2	2
Mvmt Flow	8	0	0	49	0	79	0	555	78	121	454	0

Major/Minor	Minor2		Minor1		Major1		Major2					
Conflicting Flow All	1330	1329	454	1251	1251	555	454	0	0	633	0	0
Stage 1	696	696	-	555	555	-	-	-	-	-	-	-
Stage 2	634	633	-	696	696	-	-	-	-	-	-	-
Critical Hdwy	7.12	6.52	6.22	7.12	6.52	6.22	4.12	-	-	4.12	-	-
Critical Hdwy Stg 1	6.12	5.52	-	6.12	5.52	-	-	-	-	-	-	-
Critical Hdwy Stg 2	6.12	5.52	-	6.12	5.52	-	-	-	-	-	-	-
Follow-up Hdwy	3.518	4.018	3.318	3.518	4.018	3.318	2.218	-	-	2.218	-	-
Pot Cap-1 Maneuver	132	155	606	149	172	531	1107	-	-	950	-	-
Stage 1	432	443	-	516	513	-	-	-	-	-	-	-
Stage 2	467	473	-	432	443	-	-	-	-	-	-	-
Platoon blocked, %								-	-	-	-	-
Mov Cap-1 Maneuver	101	135	606	134	150	531	1107	-	-	950	-	-
Mov Cap-2 Maneuver	101	135	-	134	150	-	-	-	-	-	-	-
Stage 1	432	387	-	516	513	-	-	-	-	-	-	-
Stage 2	398	473	-	377	387	-	-	-	-	-	-	-

Approach	EB		WB		NB		SB	
HCM Control Delay, s	43.6		25.9		0		2	
HCM LOS	E		D					

Minor Lane/Major Mvmt	NBL	NBT	NBR	EBLn1	WBLn1	WBLn2	SBL	SBT	SBR
Capacity (veh/h)	1107	-	-	101	134	531	950	-	-
HCM Lane V/C Ratio	-	-	-	0.078	0.366	0.149	0.128	-	-
HCM Control Delay (s)	0	-	-	43.6	46.6	13	9.3	-	-
HCM Lane LOS	A	-	-	E	E	B	A	-	-
HCM 95th %tile Q(veh)	0	-	-	0.2	1.5	0.5	0.4	-	-

Intersection						
Int Delay, s/veh	4.6					
Movement	EBT	EBR	WBL	WBT	NBL	NBR
Lane Configurations	↑	↗		↖	↖	↗
Traffic Vol, veh/h	81	369	35	111	258	25
Future Vol, veh/h	81	369	35	111	258	25
Conflicting Peds, #/hr	0	0	0	0	0	0
Sign Control	Free	Free	Free	Free	Stop	Stop
RT Channelized	-	None	-	None	-	None
Storage Length	-	200	-	-	0	0
Veh in Median Storage, #	0	-	-	0	0	-
Grade, %	0	-	-	0	0	-
Peak Hour Factor	92	92	68	68	100	100
Heavy Vehicles, %	2	2	2	2	2	2
Mvmt Flow	88	401	51	163	258	25

Major/Minor	Major1	Major2	Minor1		
Conflicting Flow All	0	0	489	0	353 88
Stage 1	-	-	-	-	88 -
Stage 2	-	-	-	-	265 -
Critical Hdwy	-	-	4.12	-	6.42 6.22
Critical Hdwy Stg 1	-	-	-	-	5.42 -
Critical Hdwy Stg 2	-	-	-	-	5.42 -
Follow-up Hdwy	-	-	2.218	-	3.518 3.318
Pot Cap-1 Maneuver	-	-	1074	-	645 970
Stage 1	-	-	-	-	935 -
Stage 2	-	-	-	-	779 -
Platoon blocked, %	-	-	-	-	-
Mov Cap-1 Maneuver	-	-	1074	-	611 970
Mov Cap-2 Maneuver	-	-	-	-	611 -
Stage 1	-	-	-	-	935 -
Stage 2	-	-	-	-	738 -

Approach	EB	WB	NB
HCM Control Delay, s	0	2	14.5
HCM LOS			B

Minor Lane/Major Mvmt	NBLn1	NBLn2	EBT	EBR	WBL	WBT
Capacity (veh/h)	611	970	-	-	1074	-
HCM Lane V/C Ratio	0.422	0.026	-	-	0.048	-
HCM Control Delay (s)	15.1	8.8	-	-	8.5	0
HCM Lane LOS	C	A	-	-	A	A
HCM 95th %tile Q(veh)	2.1	0.1	-	-	0.2	-

HCM 6th Signalized Intersection Summary  
 10: US 101 NB Off Ramp/Lakewood Drive & Old Redwood Highway

Existing Project Alter. A Conditions  
 Timing Plan: P.M. Peak



Movement	EBL	EBT	EBR	WBL	WBT	WBR	NBL	NBT	NBR	SBL	SBT	SBR
Lane Configurations	↔↔	↑			↑↑		↔	↔↔		↔↔		↔
Traffic Volume (veh/h)	261	421	0	0	546	192	500	412	251	249	0	577
Future Volume (veh/h)	261	421	0	0	546	192	500	412	251	249	0	577
Initial Q (Qb), veh	0	0	0	0	0	0	0	0	0	0	0	0
Ped-Bike Adj(A_pbT)	1.00		1.00	1.00		0.98	1.00		0.99	1.00		1.00
Parking Bus, Adj	1.00	1.00	1.00	1.00	1.00	1.00	1.00	1.00	1.00	1.00	1.00	1.00
Work Zone On Approach		No			No			No			No	
Adj Sat Flow, veh/h/ln	1870	1870	0	0	1870	1870	1870	1870	1870	1870	0	1870
Adj Flow Rate, veh/h	300	484	0	0	600	211	421	618	273	259	0	0
Peak Hour Factor	0.87	0.87	0.87	0.91	0.91	0.91	0.92	0.92	0.92	0.96	0.96	0.96
Percent Heavy Veh, %	2	2	0	0	2	2	2	2	2	2	0	2
Cap, veh/h	388	1010	0	0	960	337	584	805	355	0	0	0
Arrive On Green	0.11	0.54	0.00	0.00	0.37	0.37	0.33	0.33	0.33	0.00	0.00	0.00
Sat Flow, veh/h	3456	1870	0	0	2657	900	1781	2453	1083		0	
Grp Volume(v), veh/h	300	484	0	0	415	396	421	471	420		0.0	
Grp Sat Flow(s),veh/h/ln	1728	1870	0	0	1777	1687	1781	1870	1666			
Q Serve(g_s), s	6.3	11.9	0.0	0.0	14.2	14.3	15.5	16.8	16.9			
Cycle Q Clear(g_c), s	6.3	11.9	0.0	0.0	14.2	14.3	15.5	16.8	16.9			
Prop In Lane	1.00		0.00	0.00		0.53	1.00		0.65			
Lane Grp Cap(c), veh/h	388	1010	0	0	665	631	584	614	547			
V/C Ratio(X)	0.77	0.48	0.00	0.00	0.62	0.63	0.72	0.77	0.77			
Avail Cap(c_a), veh/h	418	1010	0	0	665	631	694	729	649			
HCM Platoon Ratio	1.00	1.00	1.00	1.00	1.00	1.00	1.00	1.00	1.00			
Upstream Filter(I)	1.00	1.00	0.00	0.00	1.00	1.00	1.00	1.00	1.00			
Uniform Delay (d), s/veh	32.1	10.6	0.0	0.0	19.0	19.0	22.0	22.5	22.5			
Incr Delay (d2), s/veh	8.2	1.6	0.0	0.0	4.4	4.7	3.0	4.2	4.7			
Initial Q Delay(d3),s/veh	0.0	0.0	0.0	0.0	0.0	0.0	0.0	0.0	0.0			
%ile BackOfQ(50%),veh/ln	2.9	4.6	0.0	0.0	6.1	5.9	6.5	7.6	6.9			
Unsig. Movement Delay, s/veh												
LnGrp Delay(d),s/veh	40.3	12.2	0.0	0.0	23.4	23.7	25.0	26.6	27.1			
LnGrp LOS	D	B	A	A	C	C	C	C	C			
Approach Vol, veh/h		784			811			1312				
Approach Delay, s/veh		23.0			23.5			26.2				
Approach LOS		C			C			C				
Timer - Assigned Phs		2			5	6		8				
Phs Duration (G+Y+Rc), s		45.3			12.3	33.0		29.1				
Change Period (Y+Rc), s		5.1			4.0	5.1		4.7				
Max Green Setting (Gmax), s		40.2			9.0	27.2		29.0				
Max Q Clear Time (g_c+I1), s		13.9			8.3	16.3		18.9				
Green Ext Time (p_c), s		3.1			0.1	3.8		5.2				

Intersection Summary

HCM 6th Ctrl Delay	24.6
HCM 6th LOS	C

Notes

User approved volume balancing among the lanes for turning movement.  
 Unsignalized Delay for [SBR] is excluded from calculations of the approach delay and intersection delay.

HCM 6th Signalized Intersection Summary

Existing Project Alter. A Conditions

12: US 101 SB On Ramp/US 101 SB Off Ramp & Old Redwood Highway

Timing Plan: P.M. Peak



Movement	EBL	EBT	EBR	WBL	WBT	WBR	NBL	NBT	NBR	SBL	SBT	SBR
Lane Configurations		↑↑	↗	↖	↑↑					↘	↕	
Traffic Volume (veh/h)	0	535	381	381	1024	0	0	0	0	238	0	129
Future Volume (veh/h)	0	535	381	381	1024	0	0	0	0	238	0	129
Initial Q (Qb), veh	0	0	0	0	0	0				0	0	0
Ped-Bike Adj(A_pbT)	1.00		0.98	1.00		1.00				1.00		1.00
Parking Bus, Adj	1.00	1.00	1.00	1.00	1.00	1.00				1.00	1.00	1.00
Work Zone On Approach		No			No						No	
Adj Sat Flow, veh/h/ln	0	1870	1870	1870	1870	0				1870	1870	1870
Adj Flow Rate, veh/h	0	569	405	428	1151	0				221	92	0
Peak Hour Factor	0.94	0.94	0.94	0.89	0.89	0.89				0.83	0.83	0.83
Percent Heavy Veh, %	0	2	2	2	2	0				2	2	2
Cap, veh/h	0	1416	622	458	2533	0				262	275	
Arrive On Green	0.00	0.40	0.40	0.26	0.71	0.00				0.15	0.15	0.00
Sat Flow, veh/h	0	3647	1560	1781	3647	0				1781	1870	0
Grp Volume(v), veh/h	0	569	405	428	1151	0				221	92	0
Grp Sat Flow(s),veh/h/ln	0	1777	1560	1781	1777	0				1781	1870	0
Q Serve(g_s), s	0.0	8.0	14.8	16.4	9.6	0.0				8.5	3.1	0.0
Cycle Q Clear(g_c), s	0.0	8.0	14.8	16.4	9.6	0.0				8.5	3.1	0.0
Prop In Lane	0.00		1.00	1.00		0.00				1.00		0.00
Lane Grp Cap(c), veh/h	0	1416	622	458	2533	0				262	275	
V/C Ratio(X)	0.00	0.40	0.65	0.93	0.45	0.00				0.84	0.33	
Avail Cap(c_a), veh/h	0	1416	622	458	2533	0				262	275	
HCM Platoon Ratio	1.00	1.00	1.00	1.00	1.00	1.00				1.00	1.00	1.00
Upstream Filter(I)	0.00	1.00	1.00	1.00	1.00	0.00				1.00	1.00	0.00
Uniform Delay (d), s/veh	0.0	15.1	17.1	25.4	4.3	0.0				29.1	26.8	0.0
Incr Delay (d2), s/veh	0.0	0.9	5.2	26.5	0.6	0.0				21.4	0.7	0.0
Initial Q Delay(d3),s/veh	0.0	0.0	0.0	0.0	0.0	0.0				0.0	0.0	0.0
%ile BackOfQ(50%),veh/ln	0.0	3.1	5.6	9.8	2.3	0.0				5.0	1.4	0.0
Unsig. Movement Delay, s/veh												
LnGrp Delay(d),s/veh	0.0	15.9	22.3	51.9	4.9	0.0				50.4	27.5	0.0
LnGrp LOS	A	B	C	D	A	A				D	C	
Approach Vol, veh/h		974			1579						313	
Approach Delay, s/veh		18.6			17.6						43.7	
Approach LOS		B			B						D	
Timer - Assigned Phs		2			5	6		8				
Phs Duration (G+Y+Rc), s		55.0			22.0	33.0		15.0				
Change Period (Y+Rc), s		5.1			4.0	5.1		4.7				
Max Green Setting (Gmax), s		49.9			18.0	27.9		10.3				
Max Q Clear Time (g_c+I1), s		11.6			18.4	16.8		10.5				
Green Ext Time (p_c), s		10.5			0.0	4.0		0.0				

Intersection Summary























HCM 6th Ctrl Delay	20.8
HCM 6th LOS	C

Notes

- User approved volume balancing among the lanes for turning movement.
- User approved ignoring U-Turning movement.
- Unsignalized Delay for [SBR] is excluded from calculations of the approach delay and intersection delay.

HCM 6th Signalized Intersection Summary  
 1: Old Redwood Hwy & Shiloh Road

Existing Project Alter. A Conditions  
 Timing Plan: Saturday Midday Peak

												
Movement	EBL	EBT	EBR	WBL	WBT	WBR	NBL	NBT	NBR	SBL	SBT	SBR
Lane Configurations												
Traffic Volume (veh/h)	123	472	238	21	488	6	246	243	24	73	197	180
Future Volume (veh/h)	123	472	238	21	488	6	246	243	24	73	197	180
Initial Q (Qb), veh	0	0	0	0	0	0	0	0	0	0	0	0
Ped-Bike Adj(A_pbT)	1.00		0.97	1.00		1.00	1.00		0.98	1.00		0.97
Parking Bus, Adj	1.00	1.00	1.00	1.00	1.00	1.00	1.00	1.00	1.00	1.00	1.00	1.00
Work Zone On Approach		No			No			No			No	
Adj Sat Flow, veh/h/ln	1870	1870	1870	1870	1870	1870	1870	1870	1870	1870	1870	1870
Adj Flow Rate, veh/h	138	530	267	24	567	7	265	261	26	80	216	198
Peak Hour Factor	0.89	0.89	0.89	0.86	0.86	0.86	0.93	0.93	0.93	0.91	0.91	0.91
Percent Heavy Veh, %	2	2	2	2	2	2	2	2	2	2	2	2
Cap, veh/h	458	481	396	24	574	508	218	426	353	90	292	240
Arrive On Green	0.26	0.26	0.26	0.32	0.32	0.32	0.12	0.23	0.23	0.05	0.16	0.16
Sat Flow, veh/h	1781	1870	1539	76	1791	1585	1781	1870	1551	1781	1870	1535
Grp Volume(v), veh/h	138	530	267	591	0	7	265	261	26	80	216	198
Grp Sat Flow(s),veh/h/ln	1781	1870	1539	1867	0	1585	1781	1870	1551	1781	1870	1535
Q Serve(g_s), s	7.4	30.5	18.5	37.3	0.0	0.4	14.5	14.8	1.6	5.3	13.1	14.8
Cycle Q Clear(g_c), s	7.4	30.5	18.5	37.3	0.0	0.4	14.5	14.8	1.6	5.3	13.1	14.8
Prop In Lane	1.00		1.00	0.04		1.00	1.00		1.00	1.00		1.00
Lane Grp Cap(c), veh/h	458	481	396	599	0	508	218	426	353	90	292	240
V/C Ratio(X)	0.30	1.10	0.67	0.99	0.00	0.01	1.22	0.61	0.07	0.89	0.74	0.83
Avail Cap(c_a), veh/h	458	481	396	599	0	508	218	687	569	90	552	453
HCM Platoon Ratio	1.00	1.00	1.00	1.00	1.00	1.00	1.00	1.00	1.00	1.00	1.00	1.00
Upstream Filter(I)	1.00	1.00	1.00	1.00	0.00	1.00	1.00	1.00	1.00	1.00	1.00	1.00
Uniform Delay (d), s/veh	35.4	44.0	39.5	40.0	0.0	27.5	52.0	41.1	35.9	55.9	47.7	48.4
Incr Delay (d2), s/veh	0.4	71.4	4.5	33.5	0.0	0.0	131.5	1.4	0.1	59.4	3.7	7.1
Initial Q Delay(d3),s/veh	0.0	0.0	0.0	0.0	0.0	0.0	0.0	0.0	0.0	0.0	0.0	0.0
%ile BackOfQ(50%),veh/ln	3.2	23.2	7.2	22.0	0.0	0.1	14.3	6.8	0.6	3.8	6.3	6.0
Unsig. Movement Delay, s/veh												
LnGrp Delay(d),s/veh	35.8	115.4	44.0	73.5	0.0	27.5	183.5	42.5	36.0	115.4	51.4	55.5
LnGrp LOS	D	F	D	E	A	C	F	D	D	F	D	E
Approach Vol, veh/h		935			598			552			494	
Approach Delay, s/veh		83.3			72.9			109.9			63.4	
Approach LOS		F			E			F			E	
Timer - Assigned Phs		2	3	4		6	7	8				
Phs Duration (G+Y+Rc), s		35.0	18.0	23.0		42.5	9.5	31.5				
Change Period (Y+Rc), s		4.5	3.5	4.5		4.5	3.5	4.5				
Max Green Setting (Gmax), s		30.5	14.5	35.0		38.0	6.0	43.5				
Max Q Clear Time (g_c+I1), s		32.5	16.5	16.8		39.3	7.3	16.8				
Green Ext Time (p_c), s		0.0	0.0	1.7		0.0	0.0	1.4				
<b>Intersection Summary</b>												
HCM 6th Ctrl Delay			82.8									
HCM 6th LOS			F									



HCM Signalized Intersection Capacity Analysis  
2: Shiloh Road & Hembree Ln

Existing Project Alter. A Conditions  
Timing Plan: Saturday Midday Peak



Movement	EBL	EBT	WBT	WBR	SBL	SBR
Lane Configurations	↔↔	↑	↕↔		↔	↔
Traffic Volume (vph)	622	745	715	159	160	580
Future Volume (vph)	622	745	715	159	160	580
Ideal Flow (vphpl)	1900	1900	1900	1900	1900	1900
Total Lost time (s)	4.0	4.0	4.0		4.0	4.0
Lane Util. Factor	0.97	1.00	0.95		1.00	1.00
Frpb, ped/bikes	1.00	1.00	1.00		1.00	1.00
Flpb, ped/bikes	1.00	1.00	1.00		1.00	1.00
Frt	1.00	1.00	0.97		1.00	0.85
Flt Protected	0.95	1.00	1.00		0.95	1.00
Satd. Flow (prot)	3433	1863	3435		1770	1583
Flt Permitted	0.95	1.00	1.00		0.95	1.00
Satd. Flow (perm)	3433	1863	3435		1770	1583
Peak-hour factor, PHF	0.94	0.94	0.96	0.96	0.91	0.91
Adj. Flow (vph)	662	793	745	166	176	637
RTOR Reduction (vph)	0	0	24	0	0	64
Lane Group Flow (vph)	662	793	887	0	176	573
Confl. Peds. (#/hr)	1			1		
Turn Type	Prot	NA	NA		Perm	pm+ov
Protected Phases	5	2	6			5
Permitted Phases					4	4 5
Actuated Green, G (s)	20.2	49.9	25.7		11.5	31.7
Effective Green, g (s)	20.2	49.9	25.7		11.5	31.7
Actuated g/C Ratio	0.29	0.72	0.37		0.17	0.46
Clearance Time (s)	4.0	4.0	4.0		4.0	4.0
Vehicle Extension (s)	3.0	3.0	3.0		3.0	3.0
Lane Grp Cap (vph)	999	1339	1272		293	814
v/s Ratio Prot	0.19	0.43	c0.26			c0.20
v/s Ratio Perm					0.10	0.16
v/c Ratio	0.66	0.59	0.70		0.60	0.70
Uniform Delay, d1	21.6	4.8	18.5		26.8	15.1
Progression Factor	1.00	1.00	1.00		1.00	1.00
Incremental Delay, d2	1.7	0.7	1.7		3.4	2.8
Delay (s)	23.3	5.5	20.2		30.3	17.9
Level of Service	C	A	C		C	B
Approach Delay (s)		13.6	20.2		20.6	
Approach LOS		B	C		C	

Intersection Summary				
HCM 2000 Control Delay		17.3	HCM 2000 Level of Service	B
HCM 2000 Volume to Capacity ratio		0.75		
Actuated Cycle Length (s)		69.4	Sum of lost time (s)	12.0
Intersection Capacity Utilization		67.7%	ICU Level of Service	C
Analysis Period (min)		15		
c	Critical Lane Group			

HCM 6th Signalized Intersection Summary  
 3: US 101 NB Off-Ramp & Shiloh Road

Existing Project Alter. A Conditions  
 Timing Plan: Saturday Midday Peak



Movement	EBT	EBR	WBL	WBT	NBL	NBR
Lane Configurations	↑↑			↑	↘	↗↗
Traffic Volume (veh/h)	551	0	0	952	352	814
Future Volume (veh/h)	551	0	0	952	352	814
Initial Q (Qb), veh	0	0	0	0	0	0
Ped-Bike Adj(A_pbT)		1.00	1.00		1.00	1.00
Parking Bus, Adj	1.00	1.00	1.00	1.00	1.00	1.00
Work Zone On Approach	No			No	No	
Adj Sat Flow, veh/h/ln	1870	0	0	1870	1870	1870
Adj Flow Rate, veh/h	605	0	0	1070	371	857
Peak Hour Factor	0.91	0.91	0.89	0.89	0.95	0.95
Percent Heavy Veh, %	2	0	0	2	2	2
Cap, veh/h	1799	0	0	947	661	1035
Arrive On Green	0.51	0.00	0.00	0.51	0.37	0.37
Sat Flow, veh/h	3741	0	0	1870	1781	2790
Grp Volume(v), veh/h	605	0	0	1070	371	857
Grp Sat Flow(s),veh/h/ln	1777	0	0	1870	1781	1395
Q Serve(g_s), s	6.6	0.0	0.0	33.0	10.8	18.2
Cycle Q Clear(g_c), s	6.6	0.0	0.0	33.0	10.8	18.2
Prop In Lane		0.00	0.00		1.00	1.00
Lane Grp Cap(c), veh/h	1799	0	0	947	661	1035
V/C Ratio(X)	0.34	0.00	0.00	1.13	0.56	0.83
Avail Cap(c_a), veh/h	1799	0	0	947	847	1327
HCM Platoon Ratio	1.00	1.00	1.00	1.00	1.00	1.00
Upstream Filter(I)	1.00	0.00	0.00	1.00	1.00	1.00
Uniform Delay (d), s/veh	9.6	0.0	0.0	16.1	16.3	18.6
Incr Delay (d2), s/veh	0.1	0.0	0.0	71.9	0.8	3.6
Initial Q Delay(d3),s/veh	0.0	0.0	0.0	0.0	0.0	0.0
%ile BackOfQ(50%),veh/ln	2.1	0.0	0.0	29.7	4.1	5.8
Unsig. Movement Delay, s/veh						
LnGrp Delay(d),s/veh	9.7	0.0	0.0	88.0	17.0	22.2
LnGrp LOS	A	A	A	F	B	C
Approach Vol, veh/h	605			1070	1228	
Approach Delay, s/veh	9.7			88.0	20.6	
Approach LOS	A			F	C	
Timer - Assigned Phs		2			6	8
Phs Duration (G+Y+Rc), s		37.0			37.0	28.2
Change Period (Y+Rc), s		4.0			4.0	4.0
Max Green Setting (Gmax), s		33.0			33.0	31.0
Max Q Clear Time (g_c+I1), s		8.6			35.0	20.2
Green Ext Time (p_c), s		4.0			0.0	4.0
<b>Intersection Summary</b>						
HCM 6th Ctrl Delay			43.2			
HCM 6th LOS			D			

HCM Signalized Intersection Capacity Analysis  
4: Shiloh Road & US 101 SB Off-Ramp

Existing Project Alter. A Conditions  
Timing Plan: Saturday Midday Peak



Movement	EBL	EBT	WBT	WBR	SBL	SBR
Lane Configurations		↑	↑		↘	↗
Traffic Volume (vph)	0	298	549	0	332	151
Future Volume (vph)	0	298	549	0	332	151
Ideal Flow (vphpl)	1900	1900	1900	1900	1900	1900
Total Lost time (s)		4.0	4.0		4.0	4.0
Lane Util. Factor		1.00	1.00		1.00	1.00
Frbp, ped/bikes		1.00	1.00		1.00	1.00
Flpb, ped/bikes		1.00	1.00		1.00	1.00
Frt		1.00	1.00		1.00	0.85
Flt Protected		1.00	1.00		0.95	1.00
Satd. Flow (prot)		1863	1863		1770	1583
Flt Permitted		1.00	1.00		0.95	1.00
Satd. Flow (perm)		1863	1863		1770	1583
Peak-hour factor, PHF	0.96	0.96	0.96	0.96	0.68	0.68
Adj. Flow (vph)	0	310	572	0	488	222
RTOR Reduction (vph)	0	0	0	0	0	135
Lane Group Flow (vph)	0	310	572	0	488	87
Confl. Bikes (#/hr)				2		
Turn Type		NA	NA		Perm	Perm
Protected Phases		2	6			
Permitted Phases					4	4
Actuated Green, G (s)		18.6	18.6		17.2	17.2
Effective Green, g (s)		18.6	18.6		17.2	17.2
Actuated g/C Ratio		0.42	0.42		0.39	0.39
Clearance Time (s)		4.0	4.0		4.0	4.0
Vehicle Extension (s)		3.0	3.0		3.0	3.0
Lane Grp Cap (vph)		791	791		695	621
v/s Ratio Prot		0.17	c0.31			
v/s Ratio Perm					c0.28	0.06
v/c Ratio		0.39	0.72		0.70	0.14
Uniform Delay, d1		8.7	10.5		11.2	8.5
Progression Factor		1.00	1.00		1.00	1.00
Incremental Delay, d2		0.3	3.3		3.2	0.1
Delay (s)		9.0	13.8		14.4	8.7
Level of Service		A	B		B	A
Approach Delay (s)		9.0	13.8		12.6	
Approach LOS		A	B		B	
<b>Intersection Summary</b>						
HCM 2000 Control Delay			12.3		HCM 2000 Level of Service	B
HCM 2000 Volume to Capacity ratio			0.71			
Actuated Cycle Length (s)			43.8		Sum of lost time (s)	8.0
Intersection Capacity Utilization			118.7%		ICU Level of Service	H
Analysis Period (min)			15			
c Critical Lane Group						

Intersection						
Int Delay, s/veh	1.9					
Movement	EBT	EBR	WBL	WBT	NBL	NBR
Lane Configurations	↑↑		↘	↑	↘	↘
Traffic Vol, veh/h	570	20	81	628	16	78
Future Vol, veh/h	570	20	81	628	16	78
Conflicting Peds, #/hr	0	0	0	0	1	0
Sign Control	Free	Free	Free	Free	Stop	Stop
RT Channelized	-	None	-	None	-	None
Storage Length	-	-	68	-	0	0
Veh in Median Storage, #	0	-	-	0	0	-
Grade, %	0	-	-	0	0	-
Peak Hour Factor	92	92	87	87	78	78
Heavy Vehicles, %	2	2	2	2	2	2
Mvmt Flow	620	22	93	722	21	100



















Major/Minor	Major1	Major2	Minor1			
Conflicting Flow All	0	0	642	0	1540	321
Stage 1	-	-	-	-	631	-
Stage 2	-	-	-	-	909	-
Critical Hdwy	-	-	4.13	-	6.63	6.93
Critical Hdwy Stg 1	-	-	-	-	5.83	-
Critical Hdwy Stg 2	-	-	-	-	5.43	-
Follow-up Hdwy	-	-	2.219	-	3.519	3.319
Pot Cap-1 Maneuver	-	-	941	-	116	675
Stage 1	-	-	-	-	493	-
Stage 2	-	-	-	-	392	-
Platoon blocked, %	-	-	-	-	-	-
Mov Cap-1 Maneuver	-	-	941	-	104	675
Mov Cap-2 Maneuver	-	-	-	-	104	-
Stage 1	-	-	-	-	493	-
Stage 2	-	-	-	-	353	-

Approach	EB	WB	NB
HCM Control Delay, s	0	1.1	17.5
HCM LOS			C

Minor Lane/Major Mvmt	NBLn1	NBLn2	EBT	EBR	WBL	WBT
Capacity (veh/h)	104	675	-	-	941	-
HCM Lane V/C Ratio	0.197	0.148	-	-	0.099	-
HCM Control Delay (s)	47.9	11.3	-	-	9.2	-
HCM Lane LOS	E	B	-	-	A	-
HCM 95th %tile Q(veh)	0.7	0.5	-	-	0.3	-

HCM Signalized Intersection Capacity Analysis  
6: Conde Lane & Shiloh Road

Existing Project Alter. A Conditions  
Timing Plan: Saturday Midday Peak

												
Movement	EBL	EBT	EBR	WBL	WBT	WBR	NBL	NBT	NBR	SBL	SBT	SBR
Lane Configurations												
Traffic Volume (vph)	29	386	1	9	427	204	1	0	6	197	0	28
Future Volume (vph)	29	386	1	9	427	204	1	0	6	197	0	28
Ideal Flow (vphp)	1900	1900	1900	1900	1900	1900	1900	1900	1900	1900	1900	1900
Total Lost time (s)	4.0	4.0		4.0	4.0			4.0			4.0	4.0
Lane Util. Factor	1.00	0.95		1.00	0.95			1.00			1.00	1.00
Frbp, ped/bikes	1.00	1.00		1.00	0.99			1.00			1.00	1.00
Flpb, ped/bikes	1.00	1.00		1.00	1.00			1.00			1.00	1.00
Frt	1.00	1.00		1.00	0.95			0.89			1.00	0.85
Flt Protected	0.95	1.00		0.95	1.00			0.99			0.95	1.00
Satd. Flow (prot)	1770	3538		1770	3343			1640			1770	1583
Flt Permitted	0.95	1.00		0.95	1.00			0.99			0.95	1.00
Satd. Flow (perm)	1770	3538		1770	3343			1640			1770	1583
Peak-hour factor, PHF	0.96	0.96	0.96	0.91	0.91	0.91	0.58	0.58	0.58	0.78	0.78	0.78
Adj. Flow (vph)	30	402	1	10	469	224	2	0	10	253	0	36
RTOR Reduction (vph)	0	0	0	0	55	0	0	12	0	0	0	0
Lane Group Flow (vph)	30	403	0	10	638	0	0	0	0	0	253	36
Confl. Bikes (#/hr)						2						
Turn Type	Prot	NA		Prot	NA		Split	NA		Split	NA	custom
Protected Phases	5	2		1	6		7	7		4	4	
Permitted Phases												6
Actuated Green, G (s)	0.9	15.2		0.9	15.2			1.1			12.3	15.2
Effective Green, g (s)	0.9	15.2		0.9	15.2			1.1			12.3	15.2
Actuated g/C Ratio	0.02	0.33		0.02	0.33			0.02			0.27	0.33
Clearance Time (s)	4.0	4.0		4.0	4.0			4.0			4.0	4.0
Vehicle Extension (s)	3.0	3.0		3.0	3.0			3.0			3.0	3.0
Lane Grp Cap (vph)	35	1181		35	1116			39			478	528
v/s Ratio Prot	c0.02	0.11		0.01	c0.19			c0.00			c0.14	
v/s Ratio Perm												0.02
v/c Ratio	0.86	0.34		0.29	0.57			0.01			0.53	0.07
Uniform Delay, d1	22.2	11.4		22.0	12.5			21.7			14.1	10.3
Progression Factor	1.00	1.00		1.00	1.00			1.00			1.00	1.00
Incremental Delay, d2	94.8	0.2		4.5	0.7			0.1			1.1	0.1
Delay (s)	117.0	11.6		26.4	13.2			21.7			15.2	10.4
Level of Service	F	B		C	B			C			B	B
Approach Delay (s)		18.9			13.4			21.7			14.6	
Approach LOS		B			B			C			B	
<b>Intersection Summary</b>												
HCM 2000 Control Delay			15.3			HCM 2000 Level of Service				B		
HCM 2000 Volume to Capacity ratio			0.54									
Actuated Cycle Length (s)			45.5			Sum of lost time (s)			16.0			
Intersection Capacity Utilization			48.3%			ICU Level of Service				A		
Analysis Period (min)			15									
c Critical Lane Group												

HCM 6th TWSC  
7: Driveway 1/Gridley Drive & Shiloh Road

Existing Project Alter. A Conditions  
Timing Plan: Saturday Midday Peak

Intersection												
Int Delay, s/veh	5											
Movement	EBL	EBT	EBR	WBL	WBT	WBR	NBL	NBT	NBR	SBL	SBT	SBR
Lane Configurations		↕	↗		↕		↕	↗			↕	
Traffic Vol, veh/h	20	448	112	0	447	0	116	0	0	0	0	18
Future Vol, veh/h	20	448	112	0	447	0	116	0	0	0	0	18
Conflicting Peds, #/hr	1	0	0	0	0	0	0	0	0	0	0	0
Sign Control	Free	Free	Free	Free	Free	Free	Stop	Stop	Stop	Stop	Stop	Stop
RT Channelized	-	-	None	-	-	None	-	-	None	-	-	None
Storage Length	-	-	150	-	-	-	0	-	-	-	-	-
Veh in Median Storage, #	-	0	-	-	0	-	-	0	-	-	0	-
Grade, %	-	0	-	-	0	-	-	0	-	-	0	-
Peak Hour Factor	93	93	93	88	88	88	100	100	100	56	56	56
Heavy Vehicles, %	2	2	2	2	2	2	2	2	2	2	2	2
Mvmt Flow	22	482	120	0	508	0	116	0	0	0	0	32

Major/Minor	Major1			Major2			Minor1			Minor2		
Conflicting Flow All	509	0	0	602	0	0	1050	1035	482	1095	1155	509
Stage 1	-	-	-	-	-	-	526	526	-	509	509	-
Stage 2	-	-	-	-	-	-	524	509	-	586	646	-
Critical Hdwy	4.12	-	-	4.12	-	-	7.12	6.52	6.22	7.12	6.52	6.22
Critical Hdwy Stg 1	-	-	-	-	-	-	6.12	5.52	-	6.12	5.52	-
Critical Hdwy Stg 2	-	-	-	-	-	-	6.12	5.52	-	6.12	5.52	-
Follow-up Hdwy	2.218	-	-	2.218	-	-	3.518	4.018	3.318	3.518	4.018	3.318
Pot Cap-1 Maneuver	1056	-	-	975	-	-	205	232	584	191	197	564
Stage 1	-	-	-	-	-	-	535	529	-	547	538	-
Stage 2	-	-	-	-	-	-	537	538	-	496	467	-
Platoon blocked, %	-	-	-	-	-	-	-	-	-	-	-	-
Mov Cap-1 Maneuver	1055	-	-	975	-	-	189	224	584	186	190	563
Mov Cap-2 Maneuver	-	-	-	-	-	-	189	224	-	186	190	-
Stage 1	-	-	-	-	-	-	518	512	-	529	537	-
Stage 2	-	-	-	-	-	-	506	537	-	480	452	-

Approach	EB	WB	NB	SB
HCM Control Delay, s	0.3	0	50.3	11.8
HCM LOS			F	B

Minor Lane/Major Mvmt	NBLn1	NBLn2	EBL	EBT	EBR	WBL	WBT	WBR	SBLn1
Capacity (veh/h)	189	-	1055	-	-	975	-	-	563
HCM Lane V/C Ratio	0.614	-	0.02	-	-	-	-	-	0.057
HCM Control Delay (s)	50.3	0	8.5	0	-	0	-	-	11.8
HCM Lane LOS	F	A	A	A	-	A	-	-	B
HCM 95th %tile Q(veh)	3.5	-	0.1	-	-	0	-	-	0.2

HCM 6th TWSC  
8: Old Redwood Hwy & Driveway 2

Existing Project Alter. A Conditions  
Timing Plan: Saturday Midday Peak

Intersection												
Int Delay, s/veh	4.1											
Movement	EBL	EBT	EBR	WBL	WBT	WBR	NBL	NBT	NBR	SBL	SBT	SBR
Lane Configurations		↕		↕	↕			↕	↕	↕	↕	
Traffic Vol, veh/h	1	0	2	68	0	109	1	403	66	105	342	4
Future Vol, veh/h	1	0	2	68	0	109	1	403	66	105	342	4
Conflicting Peds, #/hr	0	0	0	0	0	0	1	0	4	4	0	1
Sign Control	Stop	Stop	Stop	Stop	Stop	Stop	Free	Free	Free	Free	Free	Free
RT Channelized	-	-	None	-	-	None	-	-	None	-	-	None
Storage Length	-	-	-	0	-	-	-	-	100	50	-	-
Veh in Median Storage, #	-	0	-	-	0	-	-	0	-	-	0	-
Grade, %	-	0	-	-	0	-	-	0	-	-	0	-
Peak Hour Factor	38	38	38	100	100	100	94	94	94	93	93	93
Heavy Vehicles, %	2	2	2	2	2	2	2	2	2	2	2	2
Mvmt Flow	3	0	5	68	0	109	1	429	70	113	368	4

Major/Minor	Minor2		Minor1		Major1		Major2					
Conflicting Flow All	1118	1102	371	1034	1034	433	373	0	0	503	0	0
Stage 1	597	597	-	435	435	-	-	-	-	-	-	-
Stage 2	521	505	-	599	599	-	-	-	-	-	-	-
Critical Hdwy	7.12	6.52	6.22	7.12	6.52	6.22	4.12	-	-	4.12	-	-
Critical Hdwy Stg 1	6.12	5.52	-	6.12	5.52	-	-	-	-	-	-	-
Critical Hdwy Stg 2	6.12	5.52	-	6.12	5.52	-	-	-	-	-	-	-
Follow-up Hdwy	3.518	4.018	3.318	3.518	4.018	3.318	2.218	-	-	2.218	-	-
Pot Cap-1 Maneuver	184	212	675	210	232	623	1185	-	-	1061	-	-
Stage 1	490	491	-	600	580	-	-	-	-	-	-	-
Stage 2	539	540	-	488	490	-	-	-	-	-	-	-
Platoon blocked, %								-	-	-	-	-
Mov Cap-1 Maneuver	139	188	674	190	206	621	1184	-	-	1057	-	-
Mov Cap-2 Maneuver	139	188	-	190	206	-	-	-	-	-	-	-
Stage 1	489	438	-	597	577	-	-	-	-	-	-	-
Stage 2	444	537	-	432	437	-	-	-	-	-	-	-

Approach	EB		WB		NB		SB	
HCM Control Delay, s	17.5		20.5		0		2.1	
HCM LOS	C		C					

Minor Lane/Major Mvmt	NBL	NBT	NBR	EBLn1	WBLn1	WBLn2	SBL	SBT	SBR
Capacity (veh/h)	1184	-	-	295	190	621	1057	-	-
HCM Lane V/C Ratio	0.001	-	-	0.027	0.358	0.176	0.107	-	-
HCM Control Delay (s)	8	0	-	17.5	34.1	12	8.8	-	-
HCM Lane LOS	A	A	-	C	D	B	A	-	-
HCM 95th %tile Q(veh)	0	-	-	0.1	1.5	0.6	0.4	-	-

Intersection						
Int Delay, s/veh	6.3					
Movement	EBT	EBR	WBL	WBT	NBL	NBR
Lane Configurations	↑	↗		↖	↖	↗
Traffic Vol, veh/h	92	342	32	86	355	34
Future Vol, veh/h	92	342	32	86	355	34
Conflicting Peds, #/hr	0	1	0	0	0	0
Sign Control	Free	Free	Free	Free	Stop	Stop
RT Channelized	-	None	-	None	-	None
Storage Length	-	200	-	-	0	0
Veh in Median Storage, #	0	-	-	0	0	-
Grade, %	0	-	-	0	0	-
Peak Hour Factor	88	88	80	80	100	100
Heavy Vehicles, %	2	2	2	2	2	2
Mvmt Flow	105	389	40	108	355	34

Major/Minor	Major1	Major2	Minor1		
Conflicting Flow All	0	0	495	0	294
Stage 1	-	-	-	-	106
Stage 2	-	-	-	-	188
Critical Hdwy	-	-	4.12	-	6.42
Critical Hdwy Stg 1	-	-	-	-	5.42
Critical Hdwy Stg 2	-	-	-	-	5.42
Follow-up Hdwy	-	-	2.218	-	3.518
Pot Cap-1 Maneuver	-	-	1069	-	697
Stage 1	-	-	-	-	918
Stage 2	-	-	-	-	844
Platoon blocked, %	-	-	-	-	-
Mov Cap-1 Maneuver	-	-	1068	-	668
Mov Cap-2 Maneuver	-	-	-	-	668
Stage 1	-	-	-	-	917
Stage 2	-	-	-	-	810

Approach	EB	WB	NB
HCM Control Delay, s	0	2.3	15.7
HCM LOS			C

Minor Lane/Major Mvmt	NBLn1	NBLn2	EBT	EBR	WBL	WBT
Capacity (veh/h)	668	947	-	-	1068	-
HCM Lane V/C Ratio	0.531	0.036	-	-	0.037	-
HCM Control Delay (s)	16.3	8.9	-	-	8.5	0
HCM Lane LOS	C	A	-	-	A	A
HCM 95th %tile Q(veh)	3.1	0.1	-	-	0.1	-



HCM 6th Signalized Intersection Summary

Existing Project Alter. A Conditions

10: US 101 NB Off Ramp/Lakewood Drive & Old Redwood Highway Timing Plan: Saturday Midday Peak



Movement	EBL	EBT	EBR	WBL	WBT	WBR	NBL	NBT	NBR	SBL	SBT	SBR
Lane Configurations	↔↔	↑			↑↑		↔	↔↔		↔↔		↔
Traffic Volume (veh/h)	252	341	0	0	509	242	281	266	125	214	0	615
Future Volume (veh/h)	252	341	0	0	509	242	281	266	125	214	0	615
Initial Q (Qb), veh	0	0	0	0	0	0	0	0	0	0	0	0
Ped-Bike Adj(A_pbT)	1.00		1.00	1.00		0.99	1.00		1.00	1.00		1.00
Parking Bus, Adj	1.00	1.00	1.00	1.00	1.00	1.00	1.00	1.00	1.00	1.00	1.00	1.00
Work Zone On Approach		No			No			No			No	
Adj Sat Flow, veh/h/ln	1870	1870	0	0	1870	1870	1870	1870	1870	1870	0	1870
Adj Flow Rate, veh/h	265	359	0	0	572	272	229	353	128	243	0	0
Peak Hour Factor	0.95	0.95	0.95	0.89	0.89	0.89	0.98	0.98	0.98	0.88	0.88	0.88
Percent Heavy Veh, %	2	2	0	0	2	2	2	2	2	2	0	2
Cap, veh/h	377	1183	0	0	1070	508	380	562	200	0	0	0
Arrive On Green	0.11	0.63	0.00	0.00	0.46	0.46	0.21	0.21	0.21	0.00	0.00	0.00
Sat Flow, veh/h	3456	1870	0	0	2419	1104	1781	2632	938		0	
Grp Volume(v), veh/h	265	359	0	0	437	407	229	249	232		0.0	
Grp Sat Flow(s),veh/h/ln	1728	1870	0	0	1777	1652	1781	1870	1700			
Q Serve(g_s), s	4.7	5.6	0.0	0.0	11.2	11.2	7.4	7.7	7.9			
Cycle Q Clear(g_c), s	4.7	5.6	0.0	0.0	11.2	11.2	7.4	7.7	7.9			
Prop In Lane	1.00		0.00	0.00		0.67	1.00		0.55			
Lane Grp Cap(c), veh/h	377	1183	0	0	818	761	380	399	363			
V/C Ratio(X)	0.70	0.30	0.00	0.00	0.53	0.54	0.60	0.62	0.64			
Avail Cap(c_a), veh/h	435	1183	0	0	818	761	813	853	775			
HCM Platoon Ratio	1.00	1.00	1.00	1.00	1.00	1.00	1.00	1.00	1.00			
Upstream Filter(I)	1.00	1.00	0.00	0.00	1.00	1.00	1.00	1.00	1.00			
Uniform Delay (d), s/veh	27.3	5.3	0.0	0.0	12.3	12.3	22.6	22.7	22.8			
Incr Delay (d2), s/veh	4.2	0.7	0.0	0.0	2.5	2.7	1.5	1.6	1.9			
Initial Q Delay(d3),s/veh	0.0	0.0	0.0	0.0	0.0	0.0	0.0	0.0	0.0			
%ile BackOfQ(50%),veh/ln	2.0	1.7	0.0	0.0	4.3	4.0	3.1	3.3	3.1			
Unsig. Movement Delay, s/veh												
LnGrp Delay(d),s/veh	31.6	6.0	0.0	0.0	14.8	15.0	24.1	24.3	24.6			
LnGrp LOS	C	A	A	A	B	B	C	C	C			
Approach Vol, veh/h		624			844			710				
Approach Delay, s/veh		16.8			14.9			24.3				
Approach LOS		B			B			C				
Timer - Assigned Phs		2			5	6		8				
Phs Duration (G+Y+Rc), s		45.3			10.9	34.4		18.3				
Change Period (Y+Rc), s		5.1			4.0	5.1		4.7				
Max Green Setting (Gmax), s		40.2			8.0	28.2		29.0				
Max Q Clear Time (g_c+I1), s		7.6			6.7	13.2		9.9				
Green Ext Time (p_c), s		2.2			0.1	4.7		3.5				

Intersection Summary

HCM 6th Ctrl Delay	18.5
HCM 6th LOS	B

Notes

User approved volume balancing among the lanes for turning movement.  
 Unsignalized Delay for [SBR] is excluded from calculations of the approach delay and intersection delay.

HCM 6th Signalized Intersection Summary

Existing Project Alter. A Conditions

12: US 101 SB On Ramp/US 101 SB Off Ramp & Old Redwood Highway Timing Plan: Saturday Midday Peak



Movement	EBL	EBT	EBR	WBL	WBT	WBR	NBL	NBT	NBR	SBL	SBT	SBR
Lane Configurations		↑↑	↗	↘	↑↑					↖	↕	
Traffic Volume (veh/h)	0	483	368	428	718	0	0	0	0	199	1	76
Future Volume (veh/h)	0	483	368	428	718	0	0	0	0	199	1	76
Initial Q (Qb), veh	0	0	0	0	0	0				0	0	0
Ped-Bike Adj(A_pbT)	1.00		0.98	1.00		1.00				1.00		1.00
Parking Bus, Adj	1.00	1.00	1.00	1.00	1.00	1.00				1.00	1.00	1.00
Work Zone On Approach		No			No						No	
Adj Sat Flow, veh/h/ln	0	1870	1870	1870	1870	0				1870	1870	1870
Adj Flow Rate, veh/h	0	498	379	446	748	0				192	119	0
Peak Hour Factor	0.97	0.97	0.97	0.96	0.96	0.96				0.72	0.72	0.72
Percent Heavy Veh, %	0	2	2	2	2	0				2	2	2
Cap, veh/h	0	1381	604	484	2549	0				254	267	
Arrive On Green	0.00	0.39	0.39	0.27	0.72	0.00				0.14	0.14	0.00
Sat Flow, veh/h	0	3647	1555	1781	3647	0				1781	1870	0
Grp Volume(v), veh/h	0	498	379	446	748	0				192	119	0
Grp Sat Flow(s),veh/h/ln	0	1777	1555	1781	1777	0				1781	1870	0
Q Serve(g_s), s	0.0	7.0	13.8	17.0	5.3	0.0				7.2	4.1	0.0
Cycle Q Clear(g_c), s	0.0	7.0	13.8	17.0	5.3	0.0				7.2	4.1	0.0
Prop In Lane	0.00		1.00	1.00		0.00				1.00		0.00
Lane Grp Cap(c), veh/h	0	1381	604	484	2549	0				254	267	
V/C Ratio(X)	0.00	0.36	0.63	0.92	0.29	0.00				0.76	0.45	
Avail Cap(c_a), veh/h	0	1381	604	484	2549	0				255	267	
HCM Platoon Ratio	1.00	1.00	1.00	1.00	1.00	1.00				1.00	1.00	1.00
Upstream Filter(I)	0.00	1.00	1.00	1.00	1.00	0.00				1.00	1.00	0.00
Uniform Delay (d), s/veh	0.0	15.2	17.3	24.8	3.5	0.0				28.8	27.5	0.0
Incr Delay (d2), s/veh	0.0	0.7	4.9	23.3	0.3	0.0				12.2	1.2	0.0
Initial Q Delay(d3),s/veh	0.0	0.0	0.0	0.0	0.0	0.0				0.0	0.0	0.0
%ile BackOfQ(50%),veh/ln	0.0	2.7	5.2	9.7	1.2	0.0				3.8	1.8	0.0
Unsig. Movement Delay, s/veh												
LnGrp Delay(d),s/veh	0.0	15.9	22.2	48.0	3.8	0.0				41.0	28.6	0.0
LnGrp LOS	A	B	C	D	A	A				D	C	
Approach Vol, veh/h		877			1194						311	
Approach Delay, s/veh		18.6			20.3						36.3	
Approach LOS		B			C						D	
Timer - Assigned Phs		2			5	6		8				
Phs Duration (G+Y+Rc), s		55.3			23.0	32.3		14.7				
Change Period (Y+Rc), s		5.1			4.0	5.1		4.7				
Max Green Setting (Gmax), s		50.2			19.0	27.2		10.0				
Max Q Clear Time (g_c+I1), s		7.3			19.0	15.8		9.2				
Green Ext Time (p_c), s		5.9			0.0	3.6		0.1				

Intersection Summary

HCM 6th Ctrl Delay	21.8
HCM 6th LOS	C

Notes

- User approved volume balancing among the lanes for turning movement.
- User approved ignoring U-Turning movement.
- Unsignalized Delay for [SBR] is excluded from calculations of the approach delay and intersection delay.

Queues  
1: Old Redwood Hwy & Shiloh Road

Existing Project Alter. A Conditions  
Timing Plan: A.M. PEAK



Lane Group	EBL	EBT	EBR	WBT	WBR	NBL	NBT	NBR	SBL	SBT	SBR
Lane Group Flow (vph)	133	338	128	216	29	99	133	37	41	274	199
v/c Ratio	0.28	0.68	0.25	0.59	0.07	0.44	0.23	0.07	0.31	0.64	0.44
Control Delay	31.2	39.1	10.9	42.7	0.3	48.2	26.8	0.7	53.8	40.6	17.3
Queue Delay	0.0	0.0	0.0	0.0	0.0	0.0	0.0	0.0	0.0	0.0	0.0
Total Delay	31.2	39.1	10.9	42.7	0.3	48.2	26.8	0.7	53.8	40.6	17.3
Queue Length 50th (ft)	58	167	9	111	0	52	57	0	22	139	35
Queue Length 95th (ft)	122	295	48	224	0	127	122	3	64	253	101
Internal Link Dist (ft)		1709		528			668			695	
Turn Bay Length (ft)	375		140		50	200		98	130		93
Base Capacity (vph)	691	727	682	901	824	328	1073	944	136	835	762
Starvation Cap Reductn	0	0	0	0	0	0	0	0	0	0	0
Spillback Cap Reductn	0	0	0	0	0	0	0	0	0	0	0
Storage Cap Reductn	0	0	0	0	0	0	0	0	0	0	0
Reduced v/c Ratio	0.19	0.46	0.19	0.24	0.04	0.30	0.12	0.04	0.30	0.33	0.26

Intersection Summary

Queues

2: Shiloh Road & Hembree Ln

Existing Project Alter. A Conditions

Timing Plan: A.M. PEAK



Lane Group	EBL	EBT	WBT	SBL	SBR
Lane Group Flow (vph)	347	493	474	76	384
v/c Ratio	0.35	0.34	0.43	0.21	0.43
Control Delay	13.9	3.9	12.7	17.9	3.0
Queue Delay	0.0	0.0	0.0	0.0	0.0
Total Delay	13.9	3.9	12.7	17.9	3.0
Queue Length 50th (ft)	33	44	44	15	5
Queue Length 95th (ft)	72	94	93	51	38
Internal Link Dist (ft)		222	1709	301	
Turn Bay Length (ft)					
Base Capacity (vph)	2455	1863	3179	684	1428
Starvation Cap Reductn	0	0	0	0	0
Spillback Cap Reductn	0	0	0	0	0
Storage Cap Reductn	0	0	0	0	0
Reduced v/c Ratio	0.14	0.26	0.15	0.11	0.27

Intersection Summary

Queues  
3: US 101 NB Off-Ramp & Shiloh Road

Existing Project Alter. A Conditions  
Timing Plan: A.M. PEAK

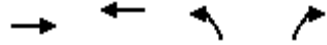

Lane Group	EBT	WBT	NBL	NBR
Lane Group Flow (vph)	332	646	568	592
v/c Ratio	0.22	0.80	0.77	0.39
Control Delay	11.2	23.7	24.1	2.2
Queue Delay	0.0	0.0	0.0	0.0
Total Delay	11.2	23.7	24.1	2.2
Queue Length 50th (ft)	37	195	171	0
Queue Length 95th (ft)	68	357	245	10
Internal Link Dist (ft)	106	291	689	
Turn Bay Length (ft)				265
Base Capacity (vph)	2166	1140	1017	1854
Starvation Cap Reductn	0	0	0	0
Spillback Cap Reductn	0	0	0	0
Storage Cap Reductn	0	0	0	0
Reduced v/c Ratio	0.15	0.57	0.56	0.32
<b>Intersection Summary</b>				

Queues  
4: Shiloh Road & US 101 SB Off-Ramp

Existing Project Alter. A Conditions  
Timing Plan: A.M. PEAK

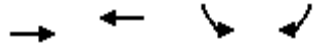

Lane Group	EBT	WBT	SBL	SBR
Lane Group Flow (vph)	258	653	163	150
v/c Ratio	0.26	0.66	0.38	0.30
Control Delay	5.5	10.1	16.8	5.5
Queue Delay	0.0	0.0	0.0	0.0
Total Delay	5.5	10.1	16.8	5.5
Queue Length 50th (ft)	22	75	26	0
Queue Length 95th (ft)	58	180	84	34
Internal Link Dist (ft)	145	226	406	
Turn Bay Length (ft)				275
Base Capacity (vph)	1863	1863	851	839
Starvation Cap Reductn	0	0	0	0
Spillback Cap Reductn	0	0	0	0
Storage Cap Reductn	0	0	0	0
Reduced v/c Ratio	0.14	0.35	0.19	0.18
<b>Intersection Summary</b>				

Queues  
6: Conde Lane & Shiloh Road

Existing Project Alter. A Conditions  
Timing Plan: A.M. PEAK

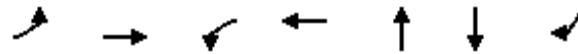

Lane Group	EBL	EBT	WBL	WBT	NBT	SBT	SBR
Lane Group Flow (vph)	26	360	11	665	28	239	41
v/c Ratio	0.07	0.27	0.03	0.55	0.06	0.46	0.08
Control Delay	23.8	11.2	23.9	13.3	0.2	25.0	14.1
Queue Delay	0.0	0.0	0.0	0.0	0.0	0.0	0.0
Total Delay	23.8	11.2	23.9	13.3	0.2	25.0	14.1
Queue Length 50th (ft)	3	18	1	31	0	29	4
Queue Length 95th (ft)	31	88	16	132	0	#196	29
Internal Link Dist (ft)		735		1001	338	442	
Turn Bay Length (ft)	90		127				40
Base Capacity (vph)	422	3021	375	2860	1343	517	1344
Starvation Cap Reductn	0	0	0	0	0	0	0
Spillback Cap Reductn	0	0	0	0	0	0	0
Storage Cap Reductn	0	0	0	0	0	0	0
Reduced v/c Ratio	0.06	0.12	0.03	0.23	0.02	0.46	0.03

Intersection Summary

# 95th percentile volume exceeds capacity, queue may be longer.  
Queue shown is maximum after two cycles.

Queues

10: US 101 NB Off Ramp/Lakewood Drive & Old Redwood Highway

Existing Project Alter. A Conditions

Timing Plan: A.M. PEAK



Lane Group	EBL	EBT	WBT	NBL	NBT	SBL	SBR
Lane Group Flow (vph)	179	208	733	194	392	133	600
v/c Ratio	0.48	0.21	0.58	0.59	0.56	0.42	0.77
Control Delay	37.6	11.6	21.6	35.0	27.4	38.9	17.2
Queue Delay	0.0	0.0	0.0	0.0	0.0	0.0	0.0
Total Delay	37.6	11.6	21.6	35.0	27.4	38.9	17.2
Queue Length 50th (ft)	41	49	135	92	82	31	119
Queue Length 95th (ft)	74	98	198	161	125	62	238
Internal Link Dist (ft)		146	537		636		
Turn Bay Length (ft)	155			270		120	
Base Capacity (vph)	403	976	1262	608	1250	313	791
Starvation Cap Reductn	0	0	0	0	0	0	0
Spillback Cap Reductn	0	0	0	0	0	0	0
Storage Cap Reductn	0	0	0	0	0	0	0
Reduced v/c Ratio	0.44	0.21	0.58	0.32	0.31	0.42	0.76

Intersection Summary



Queues

Existing Project Alter. A Conditions

12: US 101 SB On Ramp/US 101 SB Off Ramp & Old Redwood Highway

Timing Plan: A.M. PEAK



Lane Group	EBT	EBR	WBL	WBT	SBL	SBT
Lane Group Flow (vph)	324	322	576	566	120	109
v/c Ratio	0.26	0.43	0.93	0.21	0.57	0.41
Control Delay	19.6	4.4	48.8	3.1	44.7	17.5
Queue Delay	0.0	0.0	0.0	0.0	0.0	0.0
Total Delay	19.6	4.4	48.8	3.1	44.7	17.5
Queue Length 50th (ft)	61	0	267	34	60	13
Queue Length 95th (ft)	93	52	#451	46	103	50
Internal Link Dist (ft)	343			451		751
Turn Bay Length (ft)			250		420	
Base Capacity (vph)	1245	756	641	2663	210	264
Starvation Cap Reductn	0	0	0	0	0	0
Spillback Cap Reductn	0	0	0	0	0	0
Storage Cap Reductn	0	0	0	0	0	0
Reduced v/c Ratio	0.26	0.43	0.90	0.21	0.57	0.41

Intersection Summary

# 95th percentile volume exceeds capacity, queue may be longer.  
 Queue shown is maximum after two cycles.

Queues  
1: Old Redwood Hwy & Shiloh Road

Existing Project Alter. A Conditions  
Timing Plan: P.M. Peak



Lane Group	EBL	EBT	EBR	WBT	WBR	NBL	NBT	NBR	SBL	SBT	SBR
Lane Group Flow (vph)	248	532	268	460	60	225	373	23	86	266	157
v/c Ratio	0.54	1.10	0.54	0.88	0.12	1.03	0.77	0.05	0.96	0.76	0.42
Control Delay	45.2	112.3	27.4	60.4	1.3	121.0	51.9	0.2	141.0	59.9	19.1
Queue Delay	0.0	0.0	0.0	0.0	0.0	0.0	0.0	0.0	0.0	0.0	0.0
Total Delay	45.2	112.3	27.4	60.4	1.3	121.0	51.9	0.2	141.0	59.9	19.1
Queue Length 50th (ft)	169	~484	103	333	0	~194	272	0	69	200	35
Queue Length 95th (ft)	286	#790	213	#561	5	#397	390	0	#194	296	97
Internal Link Dist (ft)		1709		528			668			695	
Turn Bay Length (ft)	375		140		50	200		98	130		93
Base Capacity (vph)	460	484	496	601	573	218	691	622	90	556	534
Starvation Cap Reductn	0	0	0	0	0	0	0	0	0	0	0
Spillback Cap Reductn	0	0	0	0	0	0	0	0	0	0	0
Storage Cap Reductn	0	0	0	0	0	0	0	0	0	0	0
Reduced v/c Ratio	0.54	1.10	0.54	0.77	0.10	1.03	0.54	0.04	0.96	0.48	0.29

Intersection Summary

~ Volume exceeds capacity, queue is theoretically infinite.

Queue shown is maximum after two cycles.

# 95th percentile volume exceeds capacity, queue may be longer.

Queue shown is maximum after two cycles.

## Queues

## 2: Shiloh Road &amp; Hembree Ln

Existing Project Alter. A Conditions

Timing Plan: P.M. Peak



Lane Group	EBL	EBT	WBT	SBL	SBR
Lane Group Flow (vph)	654	921	875	179	517
v/c Ratio	0.67	0.70	0.70	0.59	0.58
Control Delay	25.9	9.1	21.5	38.0	12.1
Queue Delay	0.0	0.1	0.0	0.0	0.0
Total Delay	25.9	9.2	21.5	38.0	12.1
Queue Length 50th (ft)	124	189	157	69	96
Queue Length 95th (ft)	209	295	229	#170	235
Internal Link Dist (ft)		222	1709	301	
Turn Bay Length (ft)					
Base Capacity (vph)	1328	1757	2139	356	1030
Starvation Cap Reductn	0	81	0	0	0
Spillback Cap Reductn	0	0	0	0	0
Storage Cap Reductn	0	0	0	0	0
Reduced v/c Ratio	0.49	0.55	0.41	0.50	0.50

## Intersection Summary

# 95th percentile volume exceeds capacity, queue may be longer.

Queue shown is maximum after two cycles.

Queues  
3: US 101 NB Off-Ramp & Shiloh Road

Existing Project Alter. A Conditions  
Timing Plan: P.M. Peak

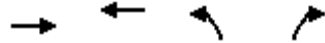

Lane Group	EBT	WBT	NBL	NBR
Lane Group Flow (vph)	597	786	584	1028
v/c Ratio	0.36	0.91	0.80	0.76
Control Delay	12.7	34.1	27.7	15.2
Queue Delay	0.0	0.0	0.0	0.0
Total Delay	12.7	34.1	27.7	15.2
Queue Length 50th (ft)	86	312	212	135
Queue Length 95th (ft)	123	#543	#352	214
Internal Link Dist (ft)	106	291	689	
Turn Bay Length (ft)				265
Base Capacity (vph)	1808	951	849	1519
Starvation Cap Reductn	0	0	0	0
Spillback Cap Reductn	0	0	0	0
Storage Cap Reductn	0	0	0	0
Reduced v/c Ratio	0.33	0.83	0.69	0.68

Intersection Summary

# 95th percentile volume exceeds capacity, queue may be longer.  
Queue shown is maximum after two cycles.

Queues  
4: Shiloh Road & US 101 SB Off-Ramp

Existing Project Alter. A Conditions  
Timing Plan: P.M. Peak

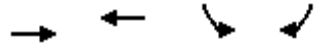

Lane Group	EBT	WBT	SBL	SBR
Lane Group Flow (vph)	515	667	322	118
v/c Ratio	0.58	0.75	0.53	0.19
Control Delay	11.5	15.8	17.6	4.6
Queue Delay	0.0	0.0	0.0	0.0
Total Delay	11.5	15.8	17.6	4.6
Queue Length 50th (ft)	91	133	65	0
Queue Length 95th (ft)	156	233	165	30
Internal Link Dist (ft)	145	226	406	
Turn Bay Length (ft)				275
Base Capacity (vph)	1863	1863	662	653
Starvation Cap Reductn	0	0	0	0
Spillback Cap Reductn	0	0	0	0
Storage Cap Reductn	0	0	0	0
Reduced v/c Ratio	0.28	0.36	0.49	0.18
<b>Intersection Summary</b>				

Queues  
6: Conde Lane & Shiloh Road

Existing Project Alter. A Conditions  
Timing Plan: P.M. Peak

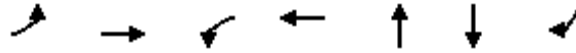

Lane Group	EBL	EBT	WBL	WBT	NBT	SBT	SBR
Lane Group Flow (vph)	78	576	9	962	40	338	44
v/c Ratio	0.29	0.32	0.03	0.70	0.12	0.95	0.07
Control Delay	33.6	10.3	32.3	17.7	17.9	73.1	14.3
Queue Delay	0.0	0.0	0.0	0.0	0.0	0.0	0.0
Total Delay	33.6	10.3	32.3	17.7	17.9	73.1	14.3
Queue Length 50th (ft)	32	67	4	166	5	~189	13
Queue Length 95th (ft)	77	132	16	190	20	#383	30
Internal Link Dist (ft)		735		1001	338	442	
Turn Bay Length (ft)	90		127				40
Base Capacity (vph)	291	2482	258	2324	1006	355	1091
Starvation Cap Reductn	0	0	0	0	0	0	0
Spillback Cap Reductn	0	0	0	0	0	0	0
Storage Cap Reductn	0	0	0	0	0	0	0
Reduced v/c Ratio	0.27	0.23	0.03	0.41	0.04	0.95	0.04

Intersection Summary

- ~ Volume exceeds capacity, queue is theoretically infinite.  
Queue shown is maximum after two cycles.
- # 95th percentile volume exceeds capacity, queue may be longer.  
Queue shown is maximum after two cycles.

Queues

10: US 101 NB Off Ramp/Lakewood Drive & Old Redwood Highway

Existing Project Alter. A Conditions

Timing Plan: P.M. Peak



Lane Group	EBL	EBT	WBT	NBL	NBT	SBL	SBR
Lane Group Flow (vph)	300	484	811	424	840	259	601
v/c Ratio	0.86	0.57	0.75	0.85	0.80	0.95	0.68
Control Delay	64.1	21.5	31.2	46.2	31.9	87.1	13.6
Queue Delay	0.0	0.0	0.0	0.0	0.0	0.0	0.0
Total Delay	64.1	21.5	31.2	46.2	31.9	87.1	13.6
Queue Length 50th (ft)	88	199	204	241	212	77	129
Queue Length 95th (ft)	#151	283	274	#413	290	#153	250
Internal Link Dist (ft)		146	537		636		
Turn Bay Length (ft)	155			270		120	
Base Capacity (vph)	349	847	1079	527	1100	272	887
Starvation Cap Reductn	0	0	0	0	0	0	0
Spillback Cap Reductn	0	0	0	0	0	0	0
Storage Cap Reductn	0	0	0	0	0	0	0
Reduced v/c Ratio	0.86	0.57	0.75	0.80	0.76	0.95	0.68

Intersection Summary

# 95th percentile volume exceeds capacity, queue may be longer.  
 Queue shown is maximum after two cycles.

Queues

Existing Project Alter. A Conditions

12: US 101 SB On Ramp/US 101 SB Off Ramp & Old Redwood Highway

Timing Plan: P.M. Peak



Lane Group	EBT	EBR	WBL	WBT	SBL	SBT
Lane Group Flow (vph)	569	405	428	1151	230	212
v/c Ratio	0.40	0.47	0.94	0.46	0.93	0.64
Control Delay	16.2	3.7	58.2	5.0	75.4	23.0
Queue Delay	0.0	0.0	0.0	0.0	0.0	0.0
Total Delay	16.2	3.7	58.2	5.0	75.4	23.0
Queue Length 50th (ft)	89	0	180	87	104	37
Queue Length 95th (ft)	128	49	#340	116	#208	91
Internal Link Dist (ft)	343			451		751
Turn Bay Length (ft)			250		420	
Base Capacity (vph)	1410	864	455	2522	247	331
Starvation Cap Reductn	0	0	0	0	0	0
Spillback Cap Reductn	0	0	0	0	0	0
Storage Cap Reductn	0	0	0	0	0	0
Reduced v/c Ratio	0.40	0.47	0.94	0.46	0.93	0.64

Intersection Summary

# 95th percentile volume exceeds capacity, queue may be longer.  
 Queue shown is maximum after two cycles.



Queues  
1: Old Redwood Hwy & Shiloh Road

Existing Project Alter. A Conditions  
Timing Plan: Saturday Midday Peak



Lane Group	EBL	EBT	EBR	WBT	WBR	NBL	NBT	NBR	SBL	SBT	SBR
Lane Group Flow (vph)	138	530	267	591	7	265	261	26	80	216	198
v/c Ratio	0.30	1.11	0.55	1.00	0.01	1.23	0.61	0.06	0.90	0.72	0.53
Control Delay	39.2	116.9	27.0	77.6	0.0	182.1	47.1	0.3	128.7	61.8	16.8
Queue Delay	0.0	0.0	0.0	0.0	0.0	0.0	0.0	0.0	0.0	0.0	0.0
Total Delay	39.2	116.9	27.0	77.6	0.0	182.1	47.1	0.3	128.7	61.8	16.8
Queue Length 50th (ft)	86	~465	99	451	0	~251	180	0	62	160	28
Queue Length 95th (ft)	153	#731	200	#707	0	#455	267	0	#171	244	99
Internal Link Dist (ft)		1709		528			668			695	
Turn Bay Length (ft)	375		140		50	200		98	130		93
Base Capacity (vph)	453	477	482	593	576	215	680	615	89	547	562
Starvation Cap Reductn	0	0	0	0	0	0	0	0	0	0	0
Spillback Cap Reductn	0	0	0	0	0	0	0	0	0	0	0
Storage Cap Reductn	0	0	0	0	0	0	0	0	0	0	0
Reduced v/c Ratio	0.30	1.11	0.55	1.00	0.01	1.23	0.38	0.04	0.90	0.39	0.35

Intersection Summary

~ Volume exceeds capacity, queue is theoretically infinite.

Queue shown is maximum after two cycles.

# 95th percentile volume exceeds capacity, queue may be longer.

Queue shown is maximum after two cycles.

Queues

2: Shiloh Road & Hembree Ln

Existing Project Alter. A Conditions

Timing Plan: Saturday Midday Peak

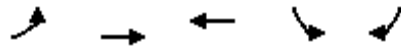

Lane Group	EBL	EBT	WBT	SBL	SBR
Lane Group Flow (vph)	662	793	911	176	637
v/c Ratio	0.67	0.60	0.71	0.60	0.73
Control Delay	26.6	7.0	22.0	40.1	17.7
Queue Delay	0.0	0.1	0.0	0.0	0.0
Total Delay	26.6	7.1	22.0	40.1	17.7
Queue Length 50th (ft)	134	144	174	73	164
Queue Length 95th (ft)	220	217	253	#173	372
Internal Link Dist (ft)		222	1709	301	
Turn Bay Length (ft)					
Base Capacity (vph)	1284	1739	2071	344	995
Starvation Cap Reductn	0	141	0	0	0
Spillback Cap Reductn	0	0	0	0	0
Storage Cap Reductn	0	0	0	0	0
Reduced v/c Ratio	0.52	0.50	0.44	0.51	0.64

Intersection Summary

# 95th percentile volume exceeds capacity, queue may be longer.  
 Queue shown is maximum after two cycles.

Queues  
3: US 101 NB Off-Ramp & Shiloh Road

Existing Project Alter. A Conditions  
Timing Plan: Saturday Midday Peak



Lane Group	EBT	WBT	NBL	NBR
Lane Group Flow (vph)	605	1070	371	857
v/c Ratio	0.32	1.06	0.64	0.75
Control Delay	9.7	66.1	22.5	14.9
Queue Delay	0.0	0.0	0.0	0.0
Total Delay	9.7	66.1	22.5	14.9
Queue Length 50th (ft)	58	~450	114	91
Queue Length 95th (ft)	124	#815	187	152
Internal Link Dist (ft)	106	291	689	
Turn Bay Length (ft)				265
Base Capacity (vph)	1913	1007	899	1583
Starvation Cap Reductn	0	0	0	0
Spillback Cap Reductn	0	0	0	0
Storage Cap Reductn	0	0	0	0
Reduced v/c Ratio	0.32	1.06	0.41	0.54

Intersection Summary

- ~ Volume exceeds capacity, queue is theoretically infinite.  
Queue shown is maximum after two cycles.
- # 95th percentile volume exceeds capacity, queue may be longer.  
Queue shown is maximum after two cycles.

Queues

4: Shiloh Road & US 101 SB Off-Ramp

Existing Project Alter. A Conditions

Timing Plan: Saturday Midday Peak

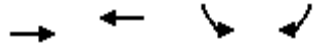

Lane Group	EBT	WBT	SBL	SBR
Lane Group Flow (vph)	310	572	488	222
v/c Ratio	0.39	0.73	0.70	0.29
Control Delay	10.0	16.3	21.2	3.5
Queue Delay	0.0	0.0	0.0	0.0
Total Delay	10.0	16.3	21.2	3.5
Queue Length 50th (ft)	49	109	96	0
Queue Length 95th (ft)	89	189	154	14
Internal Link Dist (ft)	145	226	406	
Turn Bay Length (ft)				275
Base Capacity (vph)	1863	1863	694	755
Starvation Cap Reductn	0	0	0	0
Spillback Cap Reductn	0	0	0	0
Storage Cap Reductn	0	0	0	0
Reduced v/c Ratio	0.17	0.31	0.70	0.29

Intersection Summary

Queues  
6: Conde Lane & Shiloh Road

Existing Project Alter. A Conditions  
Timing Plan: Saturday Midday Peak

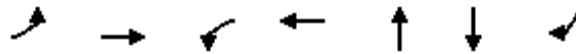

Lane Group	EBL	EBT	WBL	WBT	NBT	SBT	SBR
Lane Group Flow (vph)	30	403	10	693	12	253	36
v/c Ratio	0.07	0.29	0.02	0.52	0.02	0.46	0.06
Control Delay	19.3	10.1	19.7	10.7	0.1	21.3	10.3
Queue Delay	0.0	0.0	0.0	0.0	0.0	0.0	0.0
Total Delay	19.3	10.1	19.7	10.7	0.1	21.3	10.3
Queue Length 50th (ft)	4	21	1	35	0	35	3
Queue Length 95th (ft)	35	97	17	159	0	#187	24
Internal Link Dist (ft)		735		1001	338	442	
Turn Bay Length (ft)	90		127				40
Base Capacity (vph)	451	3258	401	3076	1443	552	1453
Starvation Cap Reductn	0	0	0	0	0	0	0
Spillback Cap Reductn	0	0	0	0	0	0	0
Storage Cap Reductn	0	0	0	0	0	0	0
Reduced v/c Ratio	0.07	0.12	0.02	0.23	0.01	0.46	0.02

Intersection Summary

# 95th percentile volume exceeds capacity, queue may be longer.  
Queue shown is maximum after two cycles.

Queues

Existing Project Alter. A Conditions

10: US 101 NB Off Ramp/Lakewood Drive & Old Redwood Highway Timing Plan: Saturday Midday Peak



Lane Group	EBL	EBT	WBT	NBL	NBT	SBL	SBR
Lane Group Flow (vph)	265	359	844	230	456	243	699
v/c Ratio	0.76	0.38	0.67	0.63	0.59	0.80	0.88
Control Delay	52.0	14.5	23.2	35.3	26.2	57.8	26.7
Queue Delay	0.0	0.0	0.0	0.0	0.0	0.0	0.0
Total Delay	52.0	14.5	23.2	35.3	26.2	57.8	26.7
Queue Length 50th (ft)	67	101	162	113	95	61	192
Queue Length 95th (ft)	#142	201	262	187	141	#134	338
Internal Link Dist (ft)		146	537		636		
Turn Bay Length (ft)	155			270		120	
Base Capacity (vph)	348	949	1256	591	1220	304	793
Starvation Cap Reductn	0	0	0	0	0	0	0
Spillback Cap Reductn	0	0	0	0	0	0	0
Storage Cap Reductn	0	0	0	0	0	0	0
Reduced v/c Ratio	0.76	0.38	0.67	0.39	0.37	0.80	0.88

Intersection Summary

# 95th percentile volume exceeds capacity, queue may be longer.  
 Queue shown is maximum after two cycles.

Queues

Existing Project Alter. A Conditions

12: US 101 SB On Ramp/US 101 SB Off Ramp & Old Redwood Highway Timing Plan: Saturday Midday Peak



























Lane Group	EBT	EBR	WBL	WBT	SBL	SBT
Lane Group Flow (vph)	498	379	446	748	199	184
v/c Ratio	0.36	0.45	0.94	0.29	0.83	0.62
Control Delay	16.1	3.8	55.6	3.9	59.3	26.6
Queue Delay	0.0	0.0	0.0	0.0	0.0	0.0
Total Delay	16.1	3.8	55.6	3.9	59.3	26.6
Queue Length 50th (ft)	77	0	186	47	89	43
Queue Length 95th (ft)	114	49	#354	67	#137	73
Internal Link Dist (ft)	343			451		751
Turn Bay Length (ft)			250		420	
Base Capacity (vph)	1381	837	480	2537	240	296
Starvation Cap Reductn	0	0	0	0	0	0
Spillback Cap Reductn	0	0	0	0	0	0
Storage Cap Reductn	0	0	0	0	0	0
Reduced v/c Ratio	0.36	0.45	0.93	0.29	0.83	0.62

Intersection Summary

# 95th percentile volume exceeds capacity, queue may be longer.  
 Queue shown is maximum after two cycles.

HCM 6th Signalized Intersection Summary  
1: Old Redwood Hwy & Shiloh Road

























Existing Plus Alternative A Project Mitigation  
Timing Plan: A.M. PEAK

												
Movement	EBL	EBT	EBR	WBL	WBT	WBR	NBL	NBT	NBR	SBL	SBT	SBR
Lane Configurations												
Traffic Volume (veh/h)	108	274	104	22	170	26	92	124	34	35	233	169
Future Volume (veh/h)	108	274	104	22	170	26	92	124	34	35	233	169
Initial Q (Qb), veh	0	0	0	0	0	0	0	0	0	0	0	0
Ped-Bike Adj(A_pbT)	1.00		1.00	1.00		1.00	1.00		1.00	1.00		0.99
Parking Bus, Adj	1.00	1.00	1.00	1.00	1.00	1.00	1.00	1.00	1.00	1.00	1.00	1.00
Work Zone On Approach		No			No			No			No	
Adj Sat Flow, veh/h/ln	1870	1870	1870	1870	1870	1870	1870	1870	1870	1870	1870	1870
Adj Flow Rate, veh/h	133	338	128	25	191	29	99	133	37	41	274	199
Peak Hour Factor	0.81	0.81	0.81	0.89	0.89	0.89	0.93	0.93	0.93	0.85	0.85	0.85
Percent Heavy Veh, %	2	2	2	2	2	2	2	2	2	2	2	2
Cap, veh/h	441	463	392	267	280	238	306	392	332	159	393	329
Arrive On Green	0.25	0.25	0.25	0.15	0.15	0.15	0.09	0.21	0.21	0.09	0.21	0.21
Sat Flow, veh/h	1781	1870	1585	1781	1870	1585	3456	1870	1585	1781	1870	1564
Grp Volume(v), veh/h	133	338	128	25	191	29	99	133	37	41	274	199
Grp Sat Flow(s),veh/h/ln	1781	1870	1585	1781	1870	1585	1728	1870	1585	1781	1870	1564
Q Serve(g_s), s	3.4	9.3	3.7	0.7	5.4	0.9	1.5	3.4	1.1	1.2	7.6	6.4
Cycle Q Clear(g_c), s	3.4	9.3	3.7	0.7	5.4	0.9	1.5	3.4	1.1	1.2	7.6	6.4
Prop In Lane	1.00		1.00	1.00		1.00	1.00		1.00	1.00		1.00
Lane Grp Cap(c), veh/h	441	463	392	267	280	238	306	392	332	159	393	329
V/C Ratio(X)	0.30	0.73	0.33	0.09	0.68	0.12	0.32	0.34	0.11	0.26	0.70	0.61
Avail Cap(c_a), veh/h	971	1019	864	1210	1270	1076	895	1454	1232	191	1170	978
HCM Platoon Ratio	1.00	1.00	1.00	1.00	1.00	1.00	1.00	1.00	1.00	1.00	1.00	1.00
Upstream Filter(I)	1.00	1.00	1.00	1.00	1.00	1.00	1.00	1.00	1.00	1.00	1.00	1.00
Uniform Delay (d), s/veh	17.1	19.3	17.2	20.5	22.5	20.6	23.9	18.8	17.9	23.7	20.4	20.0
Incr Delay (d2), s/veh	0.4	2.2	0.5	0.2	2.9	0.2	0.6	0.5	0.1	0.8	2.2	1.8
Initial Q Delay(d3),s/veh	0.0	0.0	0.0	0.0	0.0	0.0	0.0	0.0	0.0	0.0	0.0	0.0
%ile BackOfQ(50%),veh/ln	1.2	3.7	1.2	0.3	2.3	0.3	0.6	1.3	0.3	0.5	3.1	2.2
Unsig. Movement Delay, s/veh												
LnGrp Delay(d),s/veh	17.5	21.6	17.7	20.7	25.4	20.8	24.5	19.3	18.0	24.6	22.7	21.8
LnGrp LOS	B	C	B	C	C	C	C	B	B	C	C	C
Approach Vol, veh/h		599			245			269			514	
Approach Delay, s/veh		19.8			24.4			21.1			22.5	
Approach LOS		B			C			C			C	
Timer - Assigned Phs		2	3	4		6	7	8				
Phs Duration (G+Y+Rc), s		18.3	8.5	16.3		12.9	8.5	16.2				
Change Period (Y+Rc), s		4.5	3.5	4.5		4.5	3.5	4.5				
Max Green Setting (Gmax), s		30.5	14.5	35.0		38.0	6.0	43.5				
Max Q Clear Time (g_c+I1), s		11.3	3.5	9.6		7.4	3.2	5.4				
Green Ext Time (p_c), s		2.6	0.2	2.2		1.2	0.0	0.8				
<b>Intersection Summary</b>												
HCM 6th Ctrl Delay			21.6									
HCM 6th LOS			C									





















HCM 6th Signalized Intersection Summary  
1: Old Redwood Hwy & Shiloh Road

Existing Plus Alternative A Project Mitigation  
Timing Plan: P.M. Peak

												
Movement	EBL	EBT	EBR	WBL	WBT	WBR	NBL	NBT	NBR	SBL	SBT	SBR
Lane Configurations												
Traffic Volume (veh/h)	241	516	260	37	381	55	209	347	21	80	247	146
Future Volume (veh/h)	241	516	260	37	381	55	209	347	21	80	247	146
Initial Q (Qb), veh	0	0	0	0	0	0	0	0	0	0	0	0
Ped-Bike Adj(A_pbT)	1.00		1.00	1.00		1.00	1.00		0.97	1.00		0.98
Parking Bus, Adj	1.00	1.00	1.00	1.00	1.00	1.00	1.00	1.00	1.00	1.00	1.00	1.00
Work Zone On Approach		No			No			No			No	
Adj Sat Flow, veh/h/ln	1870	1870	1870	1870	1870	1870	1870	1870	1870	1870	1870	1870
Adj Flow Rate, veh/h	248	532	268	41	419	60	225	373	23	86	266	157
Peak Hour Factor	0.97	0.97	0.97	0.91	0.91	0.91	0.93	0.93	0.93	0.93	0.93	0.93
Percent Heavy Veh, %	2	2	2	2	2	2	2	2	2	2	2	2
Cap, veh/h	302	710	601	120	518	439	333	467	385	133	425	355
Arrive On Green	0.17	0.38	0.38	0.07	0.28	0.28	0.10	0.25	0.25	0.07	0.23	0.23
Sat Flow, veh/h	1781	1870	1583	1781	1870	1582	3456	1870	1543	1781	1870	1559
Grp Volume(v), veh/h	248	532	268	41	419	60	225	373	23	86	266	157
Grp Sat Flow(s),veh/h/ln	1781	1870	1583	1781	1870	1582	1728	1870	1543	1781	1870	1559
Q Serve(g_s), s	10.0	18.3	9.4	1.6	15.5	2.1	4.7	13.9	0.8	3.5	9.5	6.4
Cycle Q Clear(g_c), s	10.0	18.3	9.4	1.6	15.5	2.1	4.7	13.9	0.8	3.5	9.5	6.4
Prop In Lane	1.00		1.00	1.00		1.00	1.00		1.00	1.00		1.00
Lane Grp Cap(c), veh/h	302	710	601	120	518	439	333	467	385	133	425	355
V/C Ratio(X)	0.82	0.75	0.45	0.34	0.81	0.14	0.68	0.80	0.06	0.65	0.63	0.44
Avail Cap(c_a), veh/h	720	971	821	912	1172	992	769	1097	905	192	882	736
HCM Platoon Ratio	1.00	1.00	1.00	1.00	1.00	1.00	1.00	1.00	1.00	1.00	1.00	1.00
Upstream Filter(I)	1.00	1.00	1.00	1.00	1.00	1.00	1.00	1.00	1.00	1.00	1.00	1.00
Uniform Delay (d), s/veh	29.7	20.0	17.2	33.0	25.0	20.1	32.4	26.1	21.2	33.4	25.8	24.6
Incr Delay (d2), s/veh	5.5	2.2	0.5	1.7	3.1	0.1	2.4	3.2	0.1	5.3	1.5	0.9
Initial Q Delay(d3),s/veh	0.0	0.0	0.0	0.0	0.0	0.0	0.0	0.0	0.0	0.0	0.0	0.0
%ile BackOfQ(50%),veh/ln	4.4	7.5	3.1	0.7	6.7	0.7	1.9	6.0	0.3	1.6	4.1	2.2
Unsig. Movement Delay, s/veh												
LnGrp Delay(d),s/veh	35.2	22.1	17.7	34.7	28.0	20.3	34.8	29.3	21.3	38.6	27.3	25.5
LnGrp LOS	D	C	B	C	C	C	C	C	C	D	C	C
Approach Vol, veh/h		1048			520			621			509	
Approach Delay, s/veh		24.1			27.7			31.0			28.7	
Approach LOS		C			C			C			C	
Timer - Assigned Phs	1	2	3	4	5	6	7	8				
Phs Duration (G+Y+Rc), s	9.5	32.7	10.7	21.4	17.1	25.1	9.0	23.0				
Change Period (Y+Rc), s	4.5	4.5	3.5	4.5	4.5	4.5	3.5	4.5				
Max Green Setting (Gmax), s	38.0	38.5	16.5	35.0	30.0	46.5	8.0	43.5				
Max Q Clear Time (g_c+I1), s	3.6	20.3	6.7	11.5	12.0	17.5	5.5	15.9				
Green Ext Time (p_c), s	0.1	4.0	0.5	1.9	0.6	2.7	0.0	2.1				
<b>Intersection Summary</b>												
HCM 6th Ctrl Delay				27.2								
HCM 6th LOS				C								

HCM 6th Signalized Intersection Summary  
7: Driveway 1/Gridley Drive & Shiloh Road

Existing Plus Alternative A Project Mitigation  
Timing Plan: P.M. Peak

												
Movement	EBL	EBT	EBR	WBL	WBT	WBR	NBL	NBT	NBR	SBL	SBT	SBR
Lane Configurations												
Traffic Volume (veh/h)	17	472	121	0	383	0	84	0	0	0	0	14
Future Volume (veh/h)	17	472	121	0	383	0	84	0	0	0	0	14
Initial Q (Qb), veh	0	0	0	0	0	0	0	0	0	0	0	0
Ped-Bike Adj(A_pbT)	1.00		0.99	1.00		1.00	1.00		1.00	1.00		1.00
Parking Bus, Adj	1.00	1.00	1.00	1.00	1.00	1.00	1.00	1.00	1.00	1.00	1.00	1.00
Work Zone On Approach		No			No			No			No	
Adj Sat Flow, veh/h/ln	1870	1870	1870	1870	1870	1870	1870	1870	1870	1870	1870	1870
Adj Flow Rate, veh/h	18	502	129	0	555	0	84	0	0	0	0	24
Peak Hour Factor	0.94	0.94	0.94	0.69	0.69	0.69	1.00	1.00	1.00	0.58	0.58	0.58
Percent Heavy Veh, %	2	2	2	2	2	2	2	2	2	2	2	2
Cap, veh/h	117	727	625	0	747	0	593	540	0	0	0	458
Arrive On Green	0.40	0.40	0.40	0.00	0.40	0.00	0.29	0.00	0.00	0.00	0.00	0.29
Sat Flow, veh/h	23	1820	1564	0	1870	0	1387	1870	0	0	0	1585
Grp Volume(v), veh/h	520	0	129	0	555	0	84	0	0	0	0	24
Grp Sat Flow(s),veh/h/ln	1843	0	1564	0	1870	0	1387	1870	0	0	0	1585
Q Serve(g_s), s	0.0	0.0	1.9	0.0	8.8	0.0	1.6	0.0	0.0	0.0	0.0	0.4
Cycle Q Clear(g_c), s	8.0	0.0	1.9	0.0	8.8	0.0	2.0	0.0	0.0	0.0	0.0	0.4
Prop In Lane	0.03		1.00	0.00		0.00	1.00		0.00	0.00		1.00
Lane Grp Cap(c), veh/h	844	0	625	0	747	0	593	540	0	0	0	458
V/C Ratio(X)	0.62	0.00	0.21	0.00	0.74	0.00	0.14	0.00	0.00	0.00	0.00	0.05
Avail Cap(c_a), veh/h	1490	0	1188	0	1382	0	1166	1312	0	0	0	1080
HCM Platoon Ratio	1.00	1.00	1.00	1.00	1.00	1.00	1.00	1.00	1.00	1.00	1.00	1.00
Upstream Filter(I)	1.00	0.00	1.00	0.00	1.00	0.00	1.00	0.00	0.00	0.00	0.00	1.00
Uniform Delay (d), s/veh	8.7	0.0	6.8	0.0	8.9	0.0	9.6	0.0	0.0	0.0	0.0	8.9
Incr Delay (d2), s/veh	0.7	0.0	0.2	0.0	1.5	0.0	0.1	0.0	0.0	0.0	0.0	0.0
Initial Q Delay(d3),s/veh	0.0	0.0	0.0	0.0	0.0	0.0	0.0	0.0	0.0	0.0	0.0	0.0
%ile BackOfQ(50%),veh/ln	1.9	0.0	0.4	0.0	2.2	0.0	0.4	0.0	0.0	0.0	0.0	0.1
Unsig. Movement Delay, s/veh												
LnGrp Delay(d),s/veh	9.4	0.0	7.0	0.0	10.4	0.0	9.7	0.0	0.0	0.0	0.0	8.9
LnGrp LOS	A	A	A	A	B	A	A	A	A	A	A	A
Approach Vol, veh/h		649			555			84				24
Approach Delay, s/veh		8.9			10.4			9.7				8.9
Approach LOS		A			B			A				A
Timer - Assigned Phs		2		4		6		8				
Phs Duration (G+Y+Rc), s		15.4		19.2		15.4		19.2				
Change Period (Y+Rc), s		* 5.4		* 5.4		5.4		5.4				
Max Green Setting (Gmax), s		* 24		* 26		23.6		25.6				
Max Q Clear Time (g_c+I1), s		4.0		10.0		2.4		10.8				
Green Ext Time (p_c), s		0.2		3.3		0.1		2.9				
<b>Intersection Summary</b>												
HCM 6th Ctrl Delay			9.6									
HCM 6th LOS			A									
<b>Notes</b>												
* HCM 6th computational engine requires equal clearance times for the phases crossing the barrier.												

HCM 6th Signalized Intersection Summary  
8: Old Redwood Hwy & Driveway 2

Existing Plus Alternative A Project Mitigation  
Timing Plan: P.M. Peak



Movement	EBL	EBT	EBR	WBL	WBT	WBR	NBL	NBT	NBR	SBL	SBT	SBR
Lane Configurations		↔		↖	↗			↖	↗	↖	↗	
Traffic Volume (veh/h)	3	0	0	76	0	76	0	505	94	94	427	0
Future Volume (veh/h)	3	0	0	76	0	76	0	505	94	94	427	0
Initial Q (Qb), veh	0	0	0	0	0	0	0	0	0	0	0	0
Ped-Bike Adj(A_pbT)	1.00		1.00	1.00		1.00	1.00		0.99	1.00		1.00
Parking Bus, Adj	1.00	1.00	1.00	1.00	1.00	1.00	1.00	1.00	1.00	1.00	1.00	1.00
Work Zone On Approach		No			No			No			No	
Adj Sat Flow, veh/h/ln	1870	1870	1870	1870	1870	1870	1870	1870	1870	1870	1870	1870
Adj Flow Rate, veh/h	8	0	0	76	0	76	0	555	103	100	454	0
Peak Hour Factor	0.38	0.38	0.38	1.00	1.00	1.00	0.91	0.91	0.91	0.94	0.94	0.94
Percent Heavy Veh, %	2	2	2	2	2	2	2	2	2	2	2	2
Cap, veh/h	466	0	0	554	0	364	0	860	719	393	860	0
Arrive On Green	0.23	0.00	0.00	0.23	0.00	0.23	0.00	0.46	0.46	0.46	0.46	0.00
Sat Flow, veh/h	1100	0	0	1418	0	1585	0	1870	1564	776	1870	0
Grp Volume(v), veh/h	8	0	0	76	0	76	0	555	103	100	454	0
Grp Sat Flow(s),veh/h/ln	1100	0	0	1418	0	1585	0	1870	1564	776	1870	0
Q Serve(g_s), s	0.2	0.0	0.0	0.0	0.0	1.3	0.0	7.7	1.3	3.8	5.9	0.0
Cycle Q Clear(g_c), s	1.5	0.0	0.0	1.2	0.0	1.3	0.0	7.7	1.3	11.6	5.9	0.0
Prop In Lane	1.00		0.00	1.00		1.00	0.00		1.00	1.00		0.00
Lane Grp Cap(c), veh/h	466	0	0	554	0	364	0	860	719	393	860	0
V/C Ratio(X)	0.02	0.00	0.00	0.14	0.00	0.21	0.00	0.65	0.14	0.25	0.53	0.00
Avail Cap(c_a), veh/h	865	0	0	983	0	843	0	1188	994	529	1188	0
HCM Platoon Ratio	1.00	1.00	1.00	1.00	1.00	1.00	1.00	1.00	1.00	1.00	1.00	1.00
Upstream Filter(I)	1.00	0.00	0.00	1.00	0.00	1.00	0.00	1.00	1.00	1.00	1.00	0.00
Uniform Delay (d), s/veh	11.1	0.0	0.0	10.5	0.0	10.5	0.0	7.0	5.3	11.5	6.5	0.0
Incr Delay (d2), s/veh	0.0	0.0	0.0	0.1	0.0	0.3	0.0	0.8	0.1	0.3	0.5	0.0
Initial Q Delay(d3),s/veh	0.0	0.0	0.0	0.0	0.0	0.0	0.0	0.0	0.0	0.0	0.0	0.0
%ile BackOfQ(50%),veh/ln	0.0	0.0	0.0	0.4	0.0	0.4	0.0	1.4	0.2	0.5	1.0	0.0
Unsig. Movement Delay, s/veh												
LnGrp Delay(d),s/veh	11.2	0.0	0.0	10.6	0.0	10.8	0.0	7.8	5.4	11.8	7.0	0.0
LnGrp LOS	B	A	A	B	A	B	A	A	A	B	A	A
Approach Vol, veh/h		8			152			658			554	
Approach Delay, s/veh		11.2			10.7			7.5			7.9	
Approach LOS		B			B			A			A	
Timer - Assigned Phs		2		4		6		8				
Phs Duration (G+Y+Rc), s		21.4		12.5		21.4		12.5				
Change Period (Y+Rc), s		5.8		* 4.7		5.8		* 4.7				
Max Green Setting (Gmax), s		21.5		* 18		21.5		* 18				
Max Q Clear Time (g_c+I1), s		9.7		3.5		13.6		3.3				
Green Ext Time (p_c), s		2.8		0.0		2.0		0.5				

Intersection Summary

























HCM 6th Ctrl Delay	8.0
HCM 6th LOS	A

Notes

\* HCM 6th computational engine requires equal clearance times for the phases crossing the barrier.  
User approved changes to right turn type.

HCM 6th Signalized Intersection Summary  
1: Old Redwood Hwy & Shiloh Road



















Existing Plus Alternative A Project Mitigation  
Timing Plan: Saturday Midday Peak

												
Movement	EBL	EBT	EBR	WBL	WBT	WBR	NBL	NBT	NBR	SBL	SBT	SBR
Lane Configurations												
Traffic Volume (veh/h)	123	472	238	21	488	6	246	243	24	73	197	180
Future Volume (veh/h)	123	472	238	21	488	6	246	243	24	73	197	180
Initial Q (Qb), veh	0	0	0	0	0	0	0	0	0	0	0	0
Ped-Bike Adj(A_pbT)	1.00		0.97	1.00		1.00	1.00		0.98	1.00		0.98
Parking Bus, Adj	1.00	1.00	1.00	1.00	1.00	1.00	1.00	1.00	1.00	1.00	1.00	1.00
Work Zone On Approach		No			No			No			No	
Adj Sat Flow, veh/h/ln	1870	1870	1870	1870	1870	1870	1870	1870	1870	1870	1870	1870
Adj Flow Rate, veh/h	138	530	267	24	567	7	265	261	26	80	216	198
Peak Hour Factor	0.89	0.89	0.89	0.86	0.86	0.86	0.93	0.93	0.93	0.91	0.91	0.91
Percent Heavy Veh, %	2	2	2	2	2	2	2	2	2	2	2	2
Cap, veh/h	193	750	619	127	681	577	383	398	330	130	327	272
Arrive On Green	0.11	0.40	0.40	0.07	0.36	0.36	0.11	0.21	0.21	0.07	0.17	0.17
Sat Flow, veh/h	1781	1870	1544	1781	1870	1585	3456	1870	1551	1781	1870	1556
Grp Volume(v), veh/h	138	530	267	24	567	7	265	261	26	80	216	198
Grp Sat Flow(s),veh/h/ln	1781	1870	1544	1781	1870	1585	1728	1870	1551	1781	1870	1556
Q Serve(g_s), s	5.3	16.6	8.8	0.9	19.4	0.2	5.2	9.0	0.9	3.1	7.6	8.4
Cycle Q Clear(g_c), s	5.3	16.6	8.8	0.9	19.4	0.2	5.2	9.0	0.9	3.1	7.6	8.4
Prop In Lane	1.00		1.00	1.00		1.00	1.00		1.00	1.00		1.00
Lane Grp Cap(c), veh/h	193	750	619	127	681	577	383	398	330	130	327	272
V/C Ratio(X)	0.72	0.71	0.43	0.19	0.83	0.01	0.69	0.66	0.08	0.62	0.66	0.73
Avail Cap(c_a), veh/h	762	1027	848	965	1240	1051	813	1142	946	221	934	777
HCM Platoon Ratio	1.00	1.00	1.00	1.00	1.00	1.00	1.00	1.00	1.00	1.00	1.00	1.00
Upstream Filter(I)	1.00	1.00	1.00	1.00	1.00	1.00	1.00	1.00	1.00	1.00	1.00	1.00
Uniform Delay (d), s/veh	30.2	17.6	15.2	30.7	20.3	14.2	30.0	25.3	22.1	31.6	27.0	27.4
Incr Delay (d2), s/veh	4.9	1.4	0.5	0.7	2.7	0.0	2.3	1.8	0.1	4.7	2.3	3.7
Initial Q Delay(d3),s/veh	0.0	0.0	0.0	0.0	0.0	0.0	0.0	0.0	0.0	0.0	0.0	0.0
%ile BackOfQ(50%),veh/ln	2.4	6.5	2.7	0.4	7.9	0.1	2.1	3.8	0.3	1.4	3.3	3.1
Unsig. Movement Delay, s/veh												
LnGrp Delay(d),s/veh	35.1	18.9	15.7	31.4	23.1	14.2	32.3	27.1	22.2	36.3	29.3	31.1
LnGrp LOS	D	B	B	C	C	B	C	C	C	D	C	C
Approach Vol, veh/h		935			598			552			494	
Approach Delay, s/veh		20.4			23.3			29.4			31.1	
Approach LOS		C			C			C			C	
Timer - Assigned Phs	1	2	3	4	5	6	7	8				
Phs Duration (G+Y+Rc), s	9.5	32.6	11.3	16.7	12.1	30.0	8.6	19.4				
Change Period (Y+Rc), s	4.5	4.5	3.5	4.5	4.5	4.5	3.5	4.5				
Max Green Setting (Gmax), s	38.0	38.5	16.5	35.0	30.0	46.5	8.7	42.8				
Max Q Clear Time (g_c+I1), s	2.9	18.6	7.2	10.4	7.3	21.4	5.1	11.0				
Green Ext Time (p_c), s	0.0	4.1	0.6	1.8	0.3	3.6	0.0	1.5				
<b>Intersection Summary</b>												
HCM 6th Ctrl Delay			25.1									
HCM 6th LOS			C									

HCM 6th Signalized Intersection Summary  
7: Driveway 1/Gridley Drive & Shiloh Road

Existing Plus Alternative A Project Mitigation

Timing Plan: Saturday Midday Peak

												
Movement	EBL	EBT	EBR	WBL	WBT	WBR	NBL	NBT	NBR	SBL	SBT	SBR
Lane Configurations												
Traffic Volume (veh/h)	20	448	112	0	447	0	116	0	0	0	0	18
Future Volume (veh/h)	20	448	112	0	447	0	116	0	0	0	0	18
Initial Q (Qb), veh	0	0	0	0	0	0	0	0	0	0	0	0
Ped-Bike Adj(A_pbT)	1.00		0.99	1.00		1.00	1.00		1.00	1.00		1.00
Parking Bus, Adj	1.00	1.00	1.00	1.00	1.00	1.00	1.00	1.00	1.00	1.00	1.00	1.00
Work Zone On Approach		No			No			No				No
Adj Sat Flow, veh/h/ln	1870	1870	1870	1870	1870	1870	1870	1870	1870	1870	1870	1870
Adj Flow Rate, veh/h	22	482	120	0	508	0	116	0	0	0	0	32
Peak Hour Factor	0.93	0.93	0.93	0.88	0.88	0.88	1.00	1.00	1.00	0.56	0.56	0.56
Percent Heavy Veh, %	2	2	2	2	2	2	2	2	2	2	2	2
Cap, veh/h	123	692	600	0	717	0	601	554	0	0	0	470
Arrive On Green	0.38	0.38	0.38	0.00	0.38	0.00	0.30	0.00	0.00	0.00	0.00	0.30
Sat Flow, veh/h	31	1804	1564	0	1870	0	1377	1870	0	0	0	1585
Grp Volume(v), veh/h	504	0	120	0	508	0	116	0	0	0	0	32
Grp Sat Flow(s),veh/h/ln	1835	0	1564	0	1870	0	1377	1870	0	0	0	1585
Q Serve(g_s), s	0.0	0.0	1.7	0.0	7.8	0.0	2.2	0.0	0.0	0.0	0.0	0.5
Cycle Q Clear(g_c), s	7.7	0.0	1.7	0.0	7.8	0.0	2.7	0.0	0.0	0.0	0.0	0.5
Prop In Lane	0.04		1.00	0.00		0.00	1.00		0.00	0.00		1.00
Lane Grp Cap(c), veh/h	815	0	600	0	717	0	601	554	0	0	0	470
V/C Ratio(X)	0.62	0.00	0.20	0.00	0.71	0.00	0.19	0.00	0.00	0.00	0.00	0.07
Avail Cap(c_a), veh/h	1543	0	1237	0	1441	0	1169	1325	0	0	0	1090
HCM Platoon Ratio	1.00	1.00	1.00	1.00	1.00	1.00	1.00	1.00	1.00	1.00	1.00	1.00
Upstream Filter(I)	1.00	0.00	1.00	0.00	1.00	0.00	1.00	0.00	0.00	0.00	0.00	1.00
Uniform Delay (d), s/veh	8.8	0.0	6.9	0.0	8.8	0.0	9.5	0.0	0.0	0.0	0.0	8.5
Incr Delay (d2), s/veh	0.8	0.0	0.2	0.0	1.3	0.0	0.2	0.0	0.0	0.0	0.0	0.1
Initial Q Delay(d3),s/veh	0.0	0.0	0.0	0.0	0.0	0.0	0.0	0.0	0.0	0.0	0.0	0.0
%ile BackOfQ(50%),veh/ln	1.9	0.0	0.3	0.0	2.0	0.0	0.5	0.0	0.0	0.0	0.0	0.1
Unsig. Movement Delay, s/veh												
LnGrp Delay(d),s/veh	9.5	0.0	7.1	0.0	10.1	0.0	9.7	0.0	0.0	0.0	0.0	8.6
LnGrp LOS	A	A	A	A	B	A	A	A	A	A	A	A
Approach Vol, veh/h		624			508			116				32
Approach Delay, s/veh		9.1			10.1			9.7				8.6
Approach LOS		A			B			A				A
Timer - Assigned Phs		2		4		6		8				
Phs Duration (G+Y+Rc), s		15.4		18.4		15.4		18.4				
Change Period (Y+Rc), s		* 5.4		* 5.4		5.4		5.4				
Max Green Setting (Gmax), s		* 24		* 27		23.2		26.0				
Max Q Clear Time (g_c+I1), s		4.7		9.7		2.5		9.8				
Green Ext Time (p_c), s		0.3		3.2		0.1		2.7				

Intersection Summary

HCM 6th Ctrl Delay	9.5
HCM 6th LOS	A

Notes

\* HCM 6th computational engine requires equal clearance times for the phases crossing the barrier.

Queues  
1: Old Redwood Hwy & Shiloh Road

Existing Plus Alternative A Project Mitigation  
Timing Plan: A.M. PEAK



Lane Group	EBL	EBT	EBR	WBL	WBT	WBR	NBL	NBT	NBR	SBL	SBT	SBR
Lane Group Flow (vph)	133	338	128	25	191	29	99	133	37	41	274	199
v/c Ratio	0.27	0.65	0.25	0.08	0.54	0.08	0.27	0.25	0.07	0.29	0.62	0.42
Control Delay	28.0	35.1	10.0	32.9	39.7	0.4	41.4	26.6	1.0	49.0	37.1	14.1
Queue Delay	0.0	0.0	0.0	0.0	0.0	0.0	0.0	0.0	0.0	0.0	0.0	0.0
Total Delay	28.0	35.1	10.0	32.9	39.7	0.4	41.4	26.6	1.0	49.0	37.1	14.1
Queue Length 50th (ft)	52	150	9	11	89	0	24	54	0	20	126	26
Queue Length 95th (ft)	111	270	45	37	190	0	60	120	4	61	236	85
Internal Link Dist (ft)		1709			528			668			695	
Turn Bay Length (ft)	375		150	500		50	200		98	190		105
Base Capacity (vph)	735	774	719	916	964	870	678	1104	969	144	888	816
Starvation Cap Reductn	0	0	0	0	0	0	0	0	0	0	0	0
Spillback Cap Reductn	0	0	0	0	0	0	0	0	0	0	0	0
Storage Cap Reductn	0	0	0	0	0	0	0	0	0	0	0	0
Reduced v/c Ratio	0.18	0.44	0.18	0.03	0.20	0.03	0.15	0.12	0.04	0.28	0.31	0.24

Intersection Summary

Queues  
7: Driveway 1/Gridley Drive & Shiloh Road

Existing Plus Alternative A Project Mitigation  
Timing Plan: A.M. PEAK

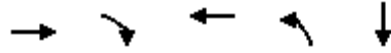

Lane Group	EBT	EBR	WBT	NBL	SBT
Lane Group Flow (vph)	323	52	187	33	24
v/c Ratio	0.47	0.08	0.27	0.09	0.05
Control Delay	8.4	2.3	6.4	8.8	3.5
Queue Delay	0.0	0.0	0.0	0.0	0.0
Total Delay	8.4	2.3	6.4	8.8	3.5
Queue Length 50th (ft)	25	0	13	3	0
Queue Length 95th (ft)	57	8	31	14	4
Internal Link Dist (ft)	528		2066		635
Turn Bay Length (ft)		150			
Base Capacity (vph)	1355	1163	1370	1016	1190
Starvation Cap Reductn	0	0	0	0	0
Spillback Cap Reductn	0	0	0	0	0
Storage Cap Reductn	0	0	0	0	0
Reduced v/c Ratio	0.24	0.04	0.14	0.03	0.02
<b>Intersection Summary</b>					

Queues  
8: Old Redwood Hwy & Driveway 2

Existing Plus Alternative A Project Mitigation  
Timing Plan: A.M. PEAK



Lane Group	EBT	WBL	WBT	NBT	NBR	SBL	SBT
Lane Group Flow (vph)	4	19	31	219	28	50	351
v/c Ratio	0.01	0.05	0.04	0.14	0.02	0.05	0.23
Control Delay	11.0	11.2	0.1	3.0	1.7	3.3	3.3
Queue Delay	0.0	0.0	0.0	0.0	0.0	0.0	0.0
Total Delay	11.0	11.2	0.1	3.0	1.7	3.3	3.3
Queue Length 50th (ft)	1	2	0	0	0	0	0
Queue Length 95th (ft)	1	11	0	36	5	12	59
Internal Link Dist (ft)	18		305	440			668
Turn Bay Length (ft)					100	50	
Base Capacity (vph)	1150	1150	1182	1545	1319	959	1545
Starvation Cap Reductn	0	0	0	0	0	0	0
Spillback Cap Reductn	0	0	0	0	0	0	0
Storage Cap Reductn	0	0	0	0	0	0	0
Reduced v/c Ratio	0.00	0.02	0.03	0.14	0.02	0.05	0.23
<b>Intersection Summary</b>							



Queues  
1: Old Redwood Hwy & Shiloh Road

Existing Plus Alternative A Project Mitigation

Timing Plan: P.M. Peak



Lane Group	EBL	EBT	EBR	WBL	WBT	WBR	NBL	NBT	NBR	SBL	SBT	SBR
Lane Group Flow (vph)	248	532	268	41	419	60	225	373	23	86	266	157
v/c Ratio	0.72	0.61	0.33	0.30	0.76	0.11	0.55	0.77	0.05	0.61	0.65	0.35
Control Delay	55.9	27.8	11.9	59.8	45.7	1.8	53.5	49.4	0.2	73.3	48.7	12.8
Queue Delay	0.0	0.0	0.0	0.0	0.0	0.0	0.0	0.0	0.0	0.0	0.0	0.0
Total Delay	55.9	27.8	11.9	59.8	45.7	1.8	53.5	49.4	0.2	73.3	48.7	12.8
Queue Length 50th (ft)	152	281	56	26	251	0	72	225	0	56	160	13
Queue Length 95th (ft)	317	514	147	78	472	9	150	427	0	#190	322	80
Internal Link Dist (ft)		1709			528			668			695	
Turn Bay Length (ft)	375		150	500		50	200		98	190		105
Base Capacity (vph)	526	867	807	667	859	767	562	803	726	140	646	627
Starvation Cap Reductn	0	0	0	0	17	0	0	0	0	0	0	0
Spillback Cap Reductn	0	0	0	0	0	0	0	0	0	0	0	0
Storage Cap Reductn	0	0	0	0	0	0	0	0	0	0	0	0
Reduced v/c Ratio	0.47	0.61	0.33	0.06	0.50	0.08	0.40	0.46	0.03	0.61	0.41	0.25

Intersection Summary

# 95th percentile volume exceeds capacity, queue may be longer.  
Queue shown is maximum after two cycles.

## Queues

## Existing Plus Alternative A Project Mitigation

## 2: Shiloh Road &amp; Hembree Ln

Timing Plan: P.M. Peak

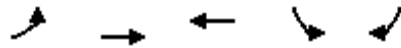

Lane Group	EBL	EBT	WBT	SBL	SBR
Lane Group Flow (vph)	654	921	875	179	517
v/c Ratio	0.67	0.70	0.70	0.59	0.58
Control Delay	25.9	9.1	21.5	38.0	12.1
Queue Delay	0.0	0.1	0.0	0.0	0.0
Total Delay	25.9	9.2	21.5	38.0	12.1
Queue Length 50th (ft)	124	189	157	69	96
Queue Length 95th (ft)	209	295	229	#170	235
Internal Link Dist (ft)		222	1709	301	
Turn Bay Length (ft)					
Base Capacity (vph)	1328	1757	2139	356	1030
Starvation Cap Reductn	0	81	0	0	0
Spillback Cap Reductn	0	0	0	0	0
Storage Cap Reductn	0	0	0	0	0
Reduced v/c Ratio	0.49	0.55	0.41	0.50	0.50

## Intersection Summary

# 95th percentile volume exceeds capacity, queue may be longer.

Queue shown is maximum after two cycles.

Queues  
3: US 101 NB Off-Ramp & Shiloh Road



Lane Group	EBT	WBT	NBL	NBR
Lane Group Flow (vph)	597	786	584	1028
v/c Ratio	0.36	0.91	0.80	0.76
Control Delay	12.7	34.1	27.7	15.2
Queue Delay	0.0	0.0	0.0	0.0
Total Delay	12.7	34.1	27.7	15.2
Queue Length 50th (ft)	86	312	212	135
Queue Length 95th (ft)	123	#543	#352	214
Internal Link Dist (ft)	106	291	689	
Turn Bay Length (ft)				265
Base Capacity (vph)	1808	951	849	1519
Starvation Cap Reductn	0	0	0	0
Spillback Cap Reductn	0	0	0	0
Storage Cap Reductn	0	0	0	0
Reduced v/c Ratio	0.33	0.83	0.69	0.68

Intersection Summary

# 95th percentile volume exceeds capacity, queue may be longer.  
Queue shown is maximum after two cycles.

Queues  
4: Shiloh Road & US 101 SB Off-Ramp

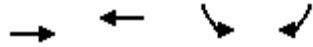

Lane Group	EBT	WBT	SBL	SBR
Lane Group Flow (vph)	515	667	322	118
v/c Ratio	0.58	0.75	0.53	0.19
Control Delay	11.5	15.8	17.6	4.6
Queue Delay	0.0	0.0	0.0	0.0
Total Delay	11.5	15.8	17.6	4.6
Queue Length 50th (ft)	91	133	65	0
Queue Length 95th (ft)	156	233	165	30
Internal Link Dist (ft)	145	226	406	
Turn Bay Length (ft)				275
Base Capacity (vph)	1863	1863	662	653
Starvation Cap Reductn	0	0	0	0
Spillback Cap Reductn	0	0	0	0
Storage Cap Reductn	0	0	0	0
Reduced v/c Ratio	0.28	0.36	0.49	0.18
<b>Intersection Summary</b>				

Queues  
6: Conde Lane & Shiloh Road

Existing Plus Alternative A Project Mitigation  
Timing Plan: P.M. Peak

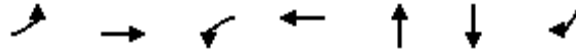

Lane Group	EBL	EBT	WBL	WBT	NBT	SBT	SBR
Lane Group Flow (vph)	78	576	9	962	40	338	44
v/c Ratio	0.29	0.32	0.03	0.70	0.12	0.95	0.07
Control Delay	33.6	10.3	32.3	17.7	17.9	73.1	14.3
Queue Delay	0.0	0.0	0.0	0.0	0.0	0.0	0.0
Total Delay	33.6	10.3	32.3	17.7	17.9	73.1	14.3
Queue Length 50th (ft)	32	67	4	166	5	~189	13
Queue Length 95th (ft)	77	132	16	190	20	#383	30
Internal Link Dist (ft)		735		1001	338	442	
Turn Bay Length (ft)	90		127				40
Base Capacity (vph)	291	2482	258	2324	1006	355	1091
Starvation Cap Reductn	0	0	0	0	0	0	0
Spillback Cap Reductn	0	0	0	0	0	0	0
Storage Cap Reductn	0	0	0	0	0	0	0
Reduced v/c Ratio	0.27	0.23	0.03	0.41	0.04	0.95	0.04

Intersection Summary

- ~ Volume exceeds capacity, queue is theoretically infinite.  
Queue shown is maximum after two cycles.
- # 95th percentile volume exceeds capacity, queue may be longer.  
Queue shown is maximum after two cycles.

Queues  
7: Driveway 1/Gridley Drive & Shiloh Road

Existing Plus Alternative A Project Mitigation  
Timing Plan: P.M. Peak

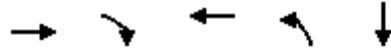

Lane Group	EBT	EBR	WBT	NBL	SBT
Lane Group Flow (vph)	520	129	555	84	24
v/c Ratio	0.63	0.17	0.69	0.21	0.04
Control Delay	11.4	1.9	13.1	13.8	0.1
Queue Delay	0.0	0.0	0.0	0.0	0.0
Total Delay	11.4	1.9	13.1	13.8	0.1
Queue Length 50th (ft)	71	0	82	13	0
Queue Length 95th (ft)	133	15	98	46	0
Internal Link Dist (ft)	528		2066		635
Turn Bay Length (ft)		150			
Base Capacity (vph)	1294	1152	1292	910	1101
Starvation Cap Reductn	0	0	0	0	0
Spillback Cap Reductn	0	0	0	0	0
Storage Cap Reductn	0	0	0	0	0
Reduced v/c Ratio	0.40	0.11	0.43	0.09	0.02
<b>Intersection Summary</b>					

Queues  
8: Old Redwood Hwy & Driveway 2

Existing Plus Alternative A Project Mitigation  
Timing Plan: P.M. Peak



Lane Group	EBT	WBL	WBT	NBT	NBR	SBL	SBT
Lane Group Flow (vph)	8	76	76	555	103	100	454
v/c Ratio	0.02	0.21	0.14	0.49	0.10	0.22	0.40
Control Delay	12.0	14.3	0.5	8.8	1.9	7.6	7.8
Queue Delay	0.0	0.0	0.0	0.0	0.0	0.0	0.0
Total Delay	12.0	14.3	0.5	8.8	1.9	7.6	7.8
Queue Length 50th (ft)	1	12	0	80	0	12	61
Queue Length 95th (ft)	4	39	0	150	14	33	115
Internal Link Dist (ft)	18		305	440			668
Turn Bay Length (ft)					100	50	
Base Capacity (vph)	610	648	840	1191	1036	488	1191
Starvation Cap Reductn	0	0	0	0	0	0	0
Spillback Cap Reductn	0	0	0	0	0	0	0
Storage Cap Reductn	0	0	0	0	0	0	0
Reduced v/c Ratio	0.01	0.12	0.09	0.47	0.10	0.20	0.38
<b>Intersection Summary</b>							

Queues

Existing Plus Alternative A Project Mitigation

10: US 101 NB Off Ramp/Lakewood Drive & Old Redwood Highway

Timing Plan: P.M. Peak



Lane Group	EBL	EBT	WBT	NBL	NBT	SBL	SBR
Lane Group Flow (vph)	300	484	811	424	840	259	601
v/c Ratio	0.86	0.57	0.75	0.85	0.80	0.95	0.68
Control Delay	64.1	21.5	31.2	46.2	31.9	87.1	13.6
Queue Delay	0.0	0.0	0.0	0.0	0.0	0.0	0.0
Total Delay	64.1	21.5	31.2	46.2	31.9	87.1	13.6
Queue Length 50th (ft)	88	199	204	241	212	77	129
Queue Length 95th (ft)	#151	283	274	#413	290	#153	250
Internal Link Dist (ft)		146	537		636		
Turn Bay Length (ft)	155			270		120	
Base Capacity (vph)	349	847	1079	527	1100	272	887
Starvation Cap Reductn	0	0	0	0	0	0	0
Spillback Cap Reductn	0	0	0	0	0	0	0
Storage Cap Reductn	0	0	0	0	0	0	0
Reduced v/c Ratio	0.86	0.57	0.75	0.80	0.76	0.95	0.68

Intersection Summary

# 95th percentile volume exceeds capacity, queue may be longer.  
 Queue shown is maximum after two cycles.



Queues

Existing Plus Alternative A Project Mitigation

12: US 101 SB On Ramp/US 101 SB Off Ramp & Old Redwood Highway

Timing Plan: P.M. Peak



Lane Group	EBT	EBR	WBL	WBT	SBL	SBT
Lane Group Flow (vph)	569	405	428	1151	230	212
v/c Ratio	0.40	0.47	0.94	0.46	0.93	0.64
Control Delay	16.2	3.7	58.2	5.0	75.4	23.0
Queue Delay	0.0	0.0	0.0	0.0	0.0	0.0
Total Delay	16.2	3.7	58.2	5.0	75.4	23.0
Queue Length 50th (ft)	89	0	180	87	104	37
Queue Length 95th (ft)	128	49	#340	116	#208	91
Internal Link Dist (ft)	343			451		751
Turn Bay Length (ft)			250		420	
Base Capacity (vph)	1410	864	455	2522	247	331
Starvation Cap Reductn	0	0	0	0	0	0
Spillback Cap Reductn	0	0	0	0	0	0
Storage Cap Reductn	0	0	0	0	0	0
Reduced v/c Ratio	0.40	0.47	0.94	0.46	0.93	0.64

Intersection Summary

# 95th percentile volume exceeds capacity, queue may be longer.  
 Queue shown is maximum after two cycles.

Queues  
1: Old Redwood Hwy & Shiloh Road

Existing Plus Alternative A Project Mitigation  
Timing Plan: Saturday Midday Peak



Lane Group	EBL	EBT	EBR	WBL	WBT	WBR	NBL	NBT	NBR	SBL	SBT	SBR
Lane Group Flow (vph)	138	530	267	24	567	7	265	261	26	80	216	198
v/c Ratio	0.57	0.57	0.32	0.20	0.79	0.01	0.59	0.63	0.06	0.54	0.66	0.49
Control Delay	55.2	23.5	10.4	56.0	39.0	0.0	51.0	44.7	0.3	66.0	52.1	15.9
Queue Delay	0.0	0.0	0.0	0.0	0.2	0.0	0.0	0.0	0.0	0.0	0.0	0.0
Total Delay	55.2	23.5	10.4	56.0	39.2	0.0	51.0	44.7	0.3	66.0	52.1	15.9
Queue Length 50th (ft)	90	258	52	16	324	0	89	163	0	54	140	25
Queue Length 95th (ft)	171	446	129	47	544	0	154	271	0	#141	245	100
Internal Link Dist (ft)		1709			528			668			695	
Turn Bay Length (ft)	375		150	500		50	200		98	190		105
Base Capacity (vph)	532	935	843	674	868	790	568	799	725	154	653	647
Starvation Cap Reductn	0	0	0	0	40	0	0	0	0	0	0	0
Spillback Cap Reductn	0	0	0	0	0	0	0	0	0	0	0	0
Storage Cap Reductn	0	0	0	0	0	0	0	0	0	0	0	0
Reduced v/c Ratio	0.26	0.57	0.32	0.04	0.68	0.01	0.47	0.33	0.04	0.52	0.33	0.31

Intersection Summary

# 95th percentile volume exceeds capacity, queue may be longer.  
Queue shown is maximum after two cycles.

Queues

Existing Plus Alternative A Project Mitigation

2: Shiloh Road & Hembree Ln

Timing Plan: Saturday Midday Peak



Lane Group	EBL	EBT	WBT	SBL	SBR
Lane Group Flow (vph)	662	793	911	176	637
v/c Ratio	0.67	0.60	0.71	0.60	0.73
Control Delay	26.6	7.0	22.0	40.1	17.7
Queue Delay	0.0	0.1	0.0	0.0	0.0
Total Delay	26.6	7.1	22.0	40.1	17.7
Queue Length 50th (ft)	134	144	174	73	164
Queue Length 95th (ft)	220	217	253	#173	372
Internal Link Dist (ft)		222	1709	301	
Turn Bay Length (ft)					
Base Capacity (vph)	1284	1739	2071	344	995
Starvation Cap Reductn	0	141	0	0	0
Spillback Cap Reductn	0	0	0	0	0
Storage Cap Reductn	0	0	0	0	0
Reduced v/c Ratio	0.52	0.50	0.44	0.51	0.64

Intersection Summary

# 95th percentile volume exceeds capacity, queue may be longer.  
 Queue shown is maximum after two cycles.

Queues  
3: US 101 NB Off-Ramp & Shiloh Road



Lane Group	EBT	WBT	NBL	NBR
Lane Group Flow (vph)	605	1070	371	857
v/c Ratio	0.32	1.06	0.64	0.75
Control Delay	9.7	66.1	22.5	14.9
Queue Delay	0.0	0.0	0.0	0.0
Total Delay	9.7	66.1	22.5	14.9
Queue Length 50th (ft)	58	-450	114	91
Queue Length 95th (ft)	124	#815	187	152
Internal Link Dist (ft)	106	291	689	
Turn Bay Length (ft)				265
Base Capacity (vph)	1913	1007	899	1583
Starvation Cap Reductn	0	0	0	0
Spillback Cap Reductn	0	0	0	0
Storage Cap Reductn	0	0	0	0
Reduced v/c Ratio	0.32	1.06	0.41	0.54

Intersection Summary

- ~ Volume exceeds capacity, queue is theoretically infinite.  
Queue shown is maximum after two cycles.
- # 95th percentile volume exceeds capacity, queue may be longer.  
Queue shown is maximum after two cycles.

Queues  
4: Shiloh Road & US 101 SB Off-Ramp

Existing Plus Alternative A Project Mitigation  
Timing Plan: Saturday Midday Peak

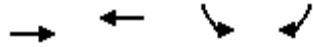

Lane Group	EBT	WBT	SBL	SBR
Lane Group Flow (vph)	310	572	488	222
v/c Ratio	0.39	0.73	0.70	0.29
Control Delay	10.0	16.3	21.2	3.5
Queue Delay	0.0	0.0	0.0	0.0
Total Delay	10.0	16.3	21.2	3.5
Queue Length 50th (ft)	49	109	96	0
Queue Length 95th (ft)	89	189	154	14
Internal Link Dist (ft)	145	226	406	
Turn Bay Length (ft)				275
Base Capacity (vph)	1863	1863	694	755
Starvation Cap Reductn	0	0	0	0
Spillback Cap Reductn	0	0	0	0
Storage Cap Reductn	0	0	0	0
Reduced v/c Ratio	0.17	0.31	0.70	0.29
Intersection Summary				

Queues  
6: Conde Lane & Shiloh Road

Existing Plus Alternative A Project Mitigation  
Timing Plan: Saturday Midday Peak

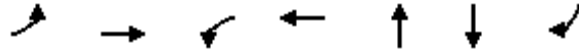

Lane Group	EBL	EBT	WBL	WBT	NBT	SBT	SBR
Lane Group Flow (vph)	30	403	10	693	12	253	36
v/c Ratio	0.07	0.29	0.02	0.52	0.02	0.46	0.06
Control Delay	19.3	10.1	19.7	10.7	0.1	21.3	10.3
Queue Delay	0.0	0.0	0.0	0.0	0.0	0.0	0.0
Total Delay	19.3	10.1	19.7	10.7	0.1	21.3	10.3
Queue Length 50th (ft)	4	21	1	35	0	35	3
Queue Length 95th (ft)	35	97	17	159	0	#187	24
Internal Link Dist (ft)		735		1001	338	442	
Turn Bay Length (ft)	90		127				40
Base Capacity (vph)	451	3258	401	3076	1443	552	1453
Starvation Cap Reductn	0	0	0	0	0	0	0
Spillback Cap Reductn	0	0	0	0	0	0	0
Storage Cap Reductn	0	0	0	0	0	0	0
Reduced v/c Ratio	0.07	0.12	0.02	0.23	0.01	0.46	0.02

Intersection Summary

# 95th percentile volume exceeds capacity, queue may be longer.  
Queue shown is maximum after two cycles.

Queues  
7: Driveway 1/Gridley Drive & Shiloh Road

Existing Plus Alternative A Project Mitigation  
Timing Plan: Saturday Midday Peak

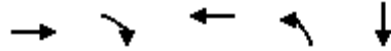

Lane Group	EBT	EBR	WBT	NBL	SBT
Lane Group Flow (vph)	504	120	508	116	32
v/c Ratio	0.64	0.16	0.66	0.28	0.05
Control Delay	12.2	2.1	13.0	13.8	0.2
Queue Delay	0.0	0.0	0.0	0.0	0.0
Total Delay	12.2	2.1	13.0	13.8	0.2
Queue Length 50th (ft)	68	0	72	16	0
Queue Length 95th (ft)	143	16	142	58	0
Internal Link Dist (ft)	528		2066		635
Turn Bay Length (ft)		150			
Base Capacity (vph)	1331	1185	1338	905	1117
Starvation Cap Reductn	0	0	0	0	0
Spillback Cap Reductn	0	0	0	0	0
Storage Cap Reductn	0	0	0	0	0
Reduced v/c Ratio	0.38	0.10	0.38	0.13	0.03
Intersection Summary					

Queues  
8: Old Redwood Hwy & Driveway 2

Existing Plus Alternative A Project Mitigation

Timing Plan: Saturday Midday Peak



Lane Group	EBT	WBL	WBT	NBT	NBR	SBL	SBT
Lane Group Flow (vph)	8	124	124	430	122	124	372
v/c Ratio	0.02	0.29	0.18	0.44	0.14	0.25	0.38
Control Delay	0.0	13.0	0.6	9.4	2.3	9.0	8.8
Queue Delay	0.0	0.0	0.0	0.0	0.0	0.0	0.0
Total Delay	0.0	13.0	0.6	9.4	2.3	9.0	8.8
Queue Length 50th (ft)	0	17	0	56	0	14	47
Queue Length 95th (ft)	0	57	0	130	19	45	110
Internal Link Dist (ft)	18		305	440			668
Turn Bay Length (ft)					100	50	
Base Capacity (vph)	809	721	956	1257	1092	637	1256
Starvation Cap Reductn	0	0	0	0	0	0	0
Spillback Cap Reductn	0	0	0	0	0	0	0
Storage Cap Reductn	0	0	0	0	0	0	0
Reduced v/c Ratio	0.01	0.17	0.13	0.34	0.11	0.19	0.30
<b>Intersection Summary</b>							



Queues

Existing Plus Alternative A Project Mitigation

10: US 101 NB Off Ramp/Lakewood Drive & Old Redwood Highway Timing Plan: Saturday Midday Peak



Lane Group	EBL	EBT	WBT	NBL	NBT	SBL	SBR
Lane Group Flow (vph)	265	359	844	230	456	243	699
v/c Ratio	0.76	0.38	0.67	0.63	0.59	0.80	0.88
Control Delay	52.0	14.5	23.2	35.3	26.2	57.8	26.7
Queue Delay	0.0	0.0	0.0	0.0	0.0	0.0	0.0
Total Delay	52.0	14.5	23.2	35.3	26.2	57.8	26.7
Queue Length 50th (ft)	67	101	162	113	95	61	192
Queue Length 95th (ft)	#142	201	262	187	141	#134	338
Internal Link Dist (ft)		146	537		636		
Turn Bay Length (ft)	155			270		120	
Base Capacity (vph)	348	949	1256	591	1220	304	793
Starvation Cap Reductn	0	0	0	0	0	0	0
Spillback Cap Reductn	0	0	0	0	0	0	0
Storage Cap Reductn	0	0	0	0	0	0	0
Reduced v/c Ratio	0.76	0.38	0.67	0.39	0.37	0.80	0.88

Intersection Summary

# 95th percentile volume exceeds capacity, queue may be longer.  
 Queue shown is maximum after two cycles.

Queues

Existing Plus Alternative A Project Mitigation

12: US 101 SB On Ramp/US 101 SB Off Ramp & Old Redwood Highway Timing Plan: Saturday Midday Peak

























Lane Group	EBT	EBR	WBL	WBT	SBL	SBT
Lane Group Flow (vph)	498	379	446	748	199	184
v/c Ratio	0.36	0.45	0.94	0.29	0.83	0.62
Control Delay	16.1	3.8	55.6	3.9	59.3	26.6
Queue Delay	0.0	0.0	0.0	0.0	0.0	0.0
Total Delay	16.1	3.8	55.6	3.9	59.3	26.6
Queue Length 50th (ft)	77	0	186	47	89	43
Queue Length 95th (ft)	114	49	#354	67	#137	73
Internal Link Dist (ft)	343			451		751
Turn Bay Length (ft)			250		420	
Base Capacity (vph)	1381	837	480	2537	240	296
Starvation Cap Reductn	0	0	0	0	0	0
Spillback Cap Reductn	0	0	0	0	0	0
Storage Cap Reductn	0	0	0	0	0	0
Reduced v/c Ratio	0.36	0.45	0.93	0.29	0.83	0.62

Intersection Summary

# 95th percentile volume exceeds capacity, queue may be longer.  
 Queue shown is maximum after two cycles.

Lanes, Volumes, Timings  
1: Old Redwood Hwy & Shiloh Road

Existing Project Alter. A Conditions  
Timing Plan: A.M. PEAK

												
Lane Group	EBL	EBT	EBR	WBL	WBT	WBR	NBL	NBT	NBR	SBL	SBT	SBR
Lane Configurations												
Traffic Volume (vph)	108	274	104	22	170	26	92	124	34	35	233	169
Future Volume (vph)	108	274	104	22	170	26	92	124	34	35	233	169
Ideal Flow (vphpl)	1900	1900	1900	1900	1900	1900	1900	1900	1900	1900	1900	1900
Storage Length (ft)	375		140	0		50	200		98	130		93
Storage Lanes	1		1	0		1	1		1	1		1
Taper Length (ft)	50			25			60			93		
Lane Util. Factor	1.00	1.00	1.00	1.00	1.00	1.00	1.00	1.00	1.00	1.00	1.00	1.00
Ped Bike Factor												0.98
Frt			0.850			0.850			0.850			0.850
Flt Protected	0.950				0.994		0.950			0.950		
Satd. Flow (prot)	1770	1863	1583	0	1852	1583	1770	1863	1583	1770	1863	1583
Flt Permitted	0.950				0.994		0.950			0.950		
Satd. Flow (perm)	1770	1863	1583	0	1852	1583	1770	1863	1583	1770	1863	1549
Right Turn on Red			Yes			Yes			Yes			Yes
Satd. Flow (RTOR)			105			105			77			123
Link Speed (mph)		40			40			45			40	
Link Distance (ft)		1789			608			748			775	
Travel Time (s)		30.5			10.4			11.3			13.2	
Confl. Bikes (#/hr)												1
Peak Hour Factor	0.81	0.81	0.81	0.89	0.89	0.89	0.93	0.93	0.93	0.85	0.85	0.85
Adj. Flow (vph)	133	338	128	25	191	29	99	133	37	41	274	199
Shared Lane Traffic (%)												
Lane Group Flow (vph)	133	338	128	0	216	29	99	133	37	41	274	199
Enter Blocked Intersection	No	No	No	No	No	No	No	No	No	No	No	No
Lane Alignment	Left	Left	Right	Left	Left	Right	Left	Left	Right	Left	Left	Right
Median Width(ft)		12			12			12			12	
Link Offset(ft)		0			0			0			0	
Crosswalk Width(ft)		16			16			16			16	
Two way Left Turn Lane												
Headway Factor	1.00	1.00	1.00	1.00	1.00	1.00	1.00	1.00	1.00	1.00	1.00	1.00
Turning Speed (mph)	15		9	15		9	15		9	15		9
Number of Detectors	1	2	1	1	2	1	1	2	1	1	2	1
Detector Template	Left	Thru	Right	Left	Thru	Right	Left	Thru	Right	Left	Thru	Right
Leading Detector (ft)	20	100	20	20	100	20	20	100	20	20	100	20
Trailing Detector (ft)	0	0	0	0	0	0	0	0	0	0	0	0
Detector 1 Position(ft)	0	0	0	0	0	0	0	0	0	0	0	0
Detector 1 Size(ft)	20	6	20	20	6	20	20	6	20	20	6	20
Detector 1 Type	Cl+Ex	Cl+Ex	Cl+Ex	Cl+Ex	Cl+Ex	Cl+Ex	Cl+Ex	Cl+Ex	Cl+Ex	Cl+Ex	Cl+Ex	Cl+Ex
Detector 1 Channel												
Detector 1 Extend (s)	0.0	0.0	0.0	0.0	0.0	0.0	0.0	0.0	0.0	0.0	0.0	0.0
Detector 1 Queue (s)	0.0	0.0	0.0	0.0	0.0	0.0	0.0	0.0	0.0	0.0	0.0	0.0
Detector 1 Delay (s)	0.0	0.0	0.0	0.0	0.0	0.0	0.0	0.0	0.0	0.0	0.0	0.0
Detector 2 Position(ft)		94			94			94			94	
Detector 2 Size(ft)		6			6			6			6	
Detector 2 Type		Cl+Ex			Cl+Ex			Cl+Ex			Cl+Ex	
Detector 2 Channel												
Detector 2 Extend (s)		0.0			0.0			0.0			0.0	
Turn Type	Split	NA	Perm	Split	NA	Perm	Prot	NA	Perm	Prot	NA	Perm

Lanes, Volumes, Timings  
1: Old Redwood Hwy & Shiloh Road

Existing Project Alter. A Conditions

Timing Plan: A.M. PEAK

Lane Group	EBL	EBT	EBR	WBL	WBT	WBR	NBL	NBT	NBR	SBL	SBT	SBR
Protected Phases	2	2		6	6		3	8		7	4	
Permitted Phases			2			6			8			4
Detector Phase	2	2	2	6	6	6	3	8	8	7	4	4
Switch Phase												
Minimum Initial (s)	5.0	5.0	5.0	5.0	5.0	5.0	5.0	5.0	5.0	5.0	5.0	5.0
Minimum Split (s)	34.5	34.5	34.5	42.5	42.5	42.5	8.5	46.5	46.5	8.5	39.5	39.5
Total Split (s)	35.0	35.0	35.0	42.5	42.5	42.5	18.0	48.0	48.0	9.5	39.5	39.5
Total Split (%)	25.9%	25.9%	25.9%	31.5%	31.5%	31.5%	13.3%	35.6%	35.6%	7.0%	29.3%	29.3%
Maximum Green (s)	30.5	30.5	30.5	38.0	38.0	38.0	14.5	43.5	43.5	6.0	35.0	35.0
Yellow Time (s)	3.5	3.5	3.5	3.5	3.5	3.5	3.0	3.5	3.5	3.0	3.5	3.5
All-Red Time (s)	1.0	1.0	1.0	1.0	1.0	1.0	0.5	1.0	1.0	0.5	1.0	1.0
Lost Time Adjust (s)	0.0	0.0	0.0		0.0	0.0	0.0	0.0	0.0	0.0	0.0	0.0
Total Lost Time (s)	4.5	4.5	4.5		4.5	4.5	3.5	4.5	4.5	3.5	4.5	4.5
Lead/Lag	Lead	Lead	Lead	Lag	Lag	Lag	Lead	Lag	Lag	Lead	Lag	Lag
Lead-Lag Optimize?	Yes	Yes	Yes	Yes	Yes	Yes	Yes	Yes	Yes	Yes	Yes	Yes
Vehicle Extension (s)	3.0	3.0	3.0	3.0	3.0	3.0	3.0	3.0	3.0	3.0	3.0	3.0
Recall Mode	None	None	None	None	None	None	None	None	None	None	None	None
Walk Time (s)	7.0	7.0	7.0	7.0	7.0	7.0		7.0	7.0		7.0	7.0
Flash Don't Walk (s)	23.0	23.0	23.0	31.0	31.0	31.0		35.0	35.0		28.0	28.0
Pedestrian Calls (#/hr)	0	0	0	0	0	0		0	0		0	0
Act Effct Green (s)	23.1	23.1	23.1		17.0	17.0	10.9	26.2	26.2	6.4	19.9	19.9
Actuated g/C Ratio	0.27	0.27	0.27		0.20	0.20	0.13	0.30	0.30	0.07	0.23	0.23
v/c Ratio	0.28	0.68	0.25		0.59	0.07	0.44	0.23	0.07	0.31	0.64	0.44
Control Delay (s/veh)	31.2	39.1	10.9		42.7	0.3	48.2	26.8	0.7	53.8	40.6	17.3
Queue Delay	0.0	0.0	0.0		0.0	0.0	0.0	0.0	0.0	0.0	0.0	0.0
Total Delay (s/veh)	31.2	39.1	10.9		42.7	0.3	48.2	26.8	0.7	53.8	40.6	17.3
LOS	C	D	B		D	A	D	C	A	D	D	B
Approach Delay (s/veh)		31.4			37.7			31.1			32.6	
Approach LOS		C			D			C			C	

Intersection Summary

Area Type:	Other
Cycle Length:	135
Actuated Cycle Length:	86
Natural Cycle:	135
Control Type:	Actuated-Uncoordinated
Maximum v/c Ratio:	0.68
Intersection Signal Delay (s/veh):	32.7
Intersection LOS:	C
Intersection Capacity Utilization:	56.5%
ICU Level of Service:	B
Analysis Period (min):	15

Splits and Phases: 1: Old Redwood Hwy & Shiloh Road

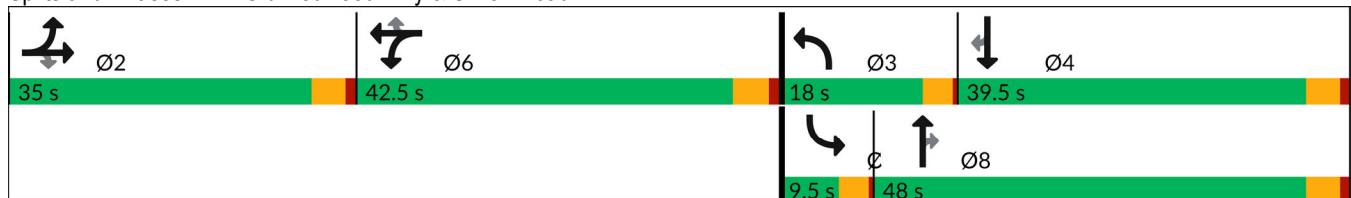

Lanes, Volumes, Timings  
2: Shiloh Road & Hembree Ln

Existing Project Alter. A Conditions  
Timing Plan: A.M. PEAK

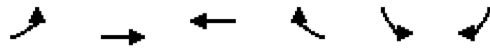

Lane Group	EBL	EBT	WBT	WBR	SBL	SBR
Lane Configurations						
Traffic Volume (vph)	305	434	392	68	71	361
Future Volume (vph)	305	434	392	68	71	361
Ideal Flow (vphpl)	1900	1900	1900	1900	1900	1900
Storage Length (ft)	0			130	0	0
Storage Lanes	2			1	1	1
Taper Length (ft)	25				25	
Lane Util. Factor	0.97	1.00	0.95	0.95	1.00	1.00
Frt			0.978			0.850
Flt Protected	0.950				0.950	
Satd. Flow (prot)	3433	1863	3461	0	1770	1583
Flt Permitted	0.950				0.950	
Satd. Flow (perm)	3433	1863	3461	0	1770	1583
Right Turn on Red				Yes		Yes
Satd. Flow (RTOR)			28			336
Link Speed (mph)		40	40		35	
Link Distance (ft)		302	1789		381	
Travel Time (s)		5.1	30.5		7.4	
Peak Hour Factor	0.88	0.88	0.97	0.97	0.94	0.94
Adj. Flow (vph)	347	493	404	70	76	384
Shared Lane Traffic (%)						
Lane Group Flow (vph)	347	493	474	0	76	384
Enter Blocked Intersection	No	No	No	No	No	No
Lane Alignment	Left	Left	Left	Right	Left	Right
Median Width(ft)		24	24		12	
Link Offset(ft)		0	0		0	
Crosswalk Width(ft)		16	16		16	
Two way Left Turn Lane						
Headway Factor	1.00	1.00	1.00	1.00	1.00	1.00
Turning Speed (mph)	15			9	15	9
Number of Detectors	1	2	2		1	1
Detector Template	Left	Thru	Thru		Left	Right
Leading Detector (ft)	20	100	100		20	20
Trailing Detector (ft)	0	0	0		0	0
Detector 1 Position(ft)	0	0	0		0	0
Detector 1 Size(ft)	20	6	6		20	20
Detector 1 Type	Cl+Ex	Cl+Ex	Cl+Ex		Cl+Ex	Cl+Ex
Detector 1 Channel						
Detector 1 Extend (s)	0.0	0.0	0.0		0.0	0.0
Detector 1 Queue (s)	0.0	0.0	0.0		0.0	0.0
Detector 1 Delay (s)	0.0	0.0	0.0		0.0	0.0
Detector 2 Position(ft)		94	94			
Detector 2 Size(ft)		6	6			
Detector 2 Type		Cl+Ex	Cl+Ex			
Detector 2 Channel						
Detector 2 Extend (s)		0.0	0.0			
Turn Type	Prot	NA	NA		Perm	pm+ov
Protected Phases	5	2	6			5
Permitted Phases					4	4 5

Lanes, Volumes, Timings  
2: Shiloh Road & Hembree Ln

Existing Project Alter. A Conditions  
Timing Plan: A.M. PEAK

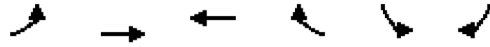

Lane Group	EBL	EBT	WBT	WBR	SBL	SBR
Detector Phase	5	2	6		4	5
Switch Phase						
Minimum Initial (s)	3.0	5.0	5.0		5.0	3.0
Minimum Split (s)	7.0	9.0	43.0		9.0	7.0
Total Split (s)	29.0	73.0	44.0		17.0	29.0
Total Split (%)	32.2%	81.1%	48.9%		18.9%	32.2%
Maximum Green (s)	25.0	69.0	40.0		13.0	25.0
Yellow Time (s)	3.0	3.0	3.0		3.0	3.0
All-Red Time (s)	1.0	1.0	1.0		1.0	1.0
Lost Time Adjust (s)	0.0	0.0	0.0		0.0	0.0
Total Lost Time (s)	4.0	4.0	4.0		4.0	4.0
Lead/Lag	Lead		Lag			Lead
Lead-Lag Optimize?	Yes		Yes			Yes
Vehicle Extension (s)	3.0	3.0	3.0		3.0	3.0
Recall Mode	None	None	None		None	None
Walk Time (s)			7.0			
Flash Don't Walk (s)			32.0			
Pedestrian Calls (#/hr)			0			
Act Effct Green (s)	10.8	29.8	11.9		7.9	16.9
Actuated g/C Ratio	0.29	0.79	0.31		0.21	0.45
v/c Ratio	0.35	0.34	0.43		0.21	0.43
Control Delay (s/veh)	13.9	3.9	12.7		17.9	3.0
Queue Delay	0.0	0.0	0.0		0.0	0.0
Total Delay (s/veh)	13.9	3.9	12.7		17.9	3.0
LOS	B	A	B		B	A
Approach Delay (s/veh)		8.0	12.7		5.5	
Approach LOS		A	B		A	

Intersection Summary

Area Type:	Other
Cycle Length:	90
Actuated Cycle Length:	37.8
Natural Cycle:	60
Control Type:	Actuated-Uncoordinated
Maximum v/c Ratio:	0.43
Intersection Signal Delay (s/veh):	8.6
Intersection LOS:	A
Intersection Capacity Utilization:	42.0%
ICU Level of Service:	A
Analysis Period (min):	15

Splits and Phases: 2: Shiloh Road & Hembree Ln



Lanes, Volumes, Timings  
 3: US 101 NB Off-Ramp & Shiloh Road

Existing Project Alter. A Conditions  
 Timing Plan: A.M. PEAK

	→	↘	↙	←	↖	↗
Lane Group	EBT	EBR	WBL	WBT	NBL	NBR
Lane Configurations	↑↑			↑	↘	↗
Traffic Volume (vph)	302	0	0	581	432	450
Future Volume (vph)	302	0	0	581	432	450
Ideal Flow (vphpl)	1900	1900	1900	1900	1900	1900
Storage Length (ft)		0	0		0	265
Storage Lanes		0	0		1	2
Taper Length (ft)			25		25	
Lane Util. Factor	0.95	1.00	1.00	1.00	1.00	0.88
Frt						0.850
Flt Protected					0.950	
Satd. Flow (prot)	3539	0	0	1863	1770	2787
Flt Permitted					0.950	
Satd. Flow (perm)	3539	0	0	1863	1770	2787
Right Turn on Red		Yes				Yes
Satd. Flow (RTOR)						592
Link Speed (mph)	40			40	30	
Link Distance (ft)	186			371	769	
Travel Time (s)	3.2			6.3	17.5	
Peak Hour Factor	0.91	0.91	0.90	0.90	0.76	0.76
Adj. Flow (vph)	332	0	0	646	568	592
Shared Lane Traffic (%)						
Lane Group Flow (vph)	332	0	0	646	568	592
Enter Blocked Intersection	No	No	No	No	No	No
Lane Alignment	Left	Right	Left	Left	Left	Right
Median Width(ft)	0			0	12	
Link Offset(ft)	0			0	0	
Crosswalk Width(ft)	16			16	16	
Two way Left Turn Lane						
Headway Factor	1.00	1.00	1.00	1.00	1.00	1.00
Turning Speed (mph)		9	15		15	9
Number of Detectors	2			2	1	1
Detector Template	Thru			Thru	Left	Right
Leading Detector (ft)	100			100	20	20
Trailing Detector (ft)	0			0	0	0
Detector 1 Position(ft)	0			0	0	0
Detector 1 Size(ft)	6			6	20	20
Detector 1 Type	Cl+Ex			Cl+Ex	Cl+Ex	Cl+Ex
Detector 1 Channel						
Detector 1 Extend (s)	0.0			0.0	0.0	0.0
Detector 1 Queue (s)	0.0			0.0	0.0	0.0
Detector 1 Delay (s)	0.0			0.0	0.0	0.0
Detector 2 Position(ft)	94			94		
Detector 2 Size(ft)	6			6		
Detector 2 Type	Cl+Ex			Cl+Ex		
Detector 2 Channel						
Detector 2 Extend (s)	0.0			0.0		
Turn Type	NA			NA	Prot	Perm
Protected Phases	2			6	8	
Permitted Phases						8

Lanes, Volumes, Timings  
 3: US 101 NB Off-Ramp & Shiloh Road

Existing Project Alter. A Conditions  
 Timing Plan: A.M. PEAK

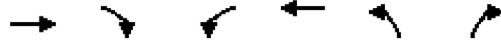

Lane Group	EBT	EBR	WBL	WBT	NBL	NBR
Detector Phase	2			6	8	8
Switch Phase						
Minimum Initial (s)	5.0			5.0	5.0	5.0
Minimum Split (s)	9.0			9.0	9.0	9.0
Total Split (s)	37.0			37.0	35.0	35.0
Total Split (%)	51.4%			51.4%	48.6%	48.6%
Maximum Green (s)	33.0			33.0	31.0	31.0
Yellow Time (s)	3.0			3.0	3.0	3.0
All-Red Time (s)	1.0			1.0	1.0	1.0
Lost Time Adjust (s)	0.0			0.0	0.0	0.0
Total Lost Time (s)	4.0			4.0	4.0	4.0
Lead/Lag						
Lead-Lag Optimize?						
Vehicle Extension (s)	3.0			3.0	3.0	3.0
Recall Mode	None			None	None	None
Act Effect Green (s)	25.3			25.3	24.1	24.1
Actuated g/C Ratio	0.44			0.44	0.42	0.42
v/c Ratio	0.22			0.80	0.77	0.39
Control Delay (s/veh)	11.2			23.7	24.1	2.2
Queue Delay	0.0			0.0	0.0	0.0
Total Delay (s/veh)	11.2			23.7	24.1	2.2
LOS	B			C	C	A
Approach Delay (s/veh)	11.2			23.7	12.9	
Approach LOS	B			C	B	

Intersection Summary

Area Type:	Other
Cycle Length:	72
Actuated Cycle Length:	58
Natural Cycle:	55
Control Type:	Actuated-Uncoordinated
Maximum v/c Ratio:	0.80
Intersection Signal Delay (s/veh):	15.9
Intersection LOS:	B
Intersection Capacity Utilization:	88.9%
ICU Level of Service:	E
Analysis Period (min):	15

Splits and Phases: 3: US 101 NB Off-Ramp & Shiloh Road

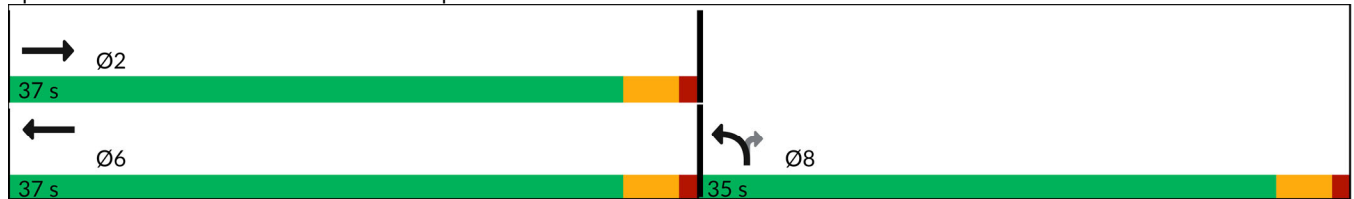



Lanes, Volumes, Timings  
4: Shiloh Road & US 101 SB Off-Ramp

Existing Project Alter. A Conditions  
Timing Plan: A.M. PEAK

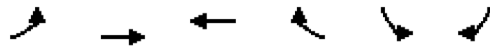

Lane Group	EBL	EBT	WBT	WBR	SBL	SBR
Lane Configurations		↑	↑		↘	↘
Traffic Volume (vph)	0	240	594	0	150	138
Future Volume (vph)	0	240	594	0	150	138
Ideal Flow (vphpl)	1900	1900	1900	1900	1900	1900
Storage Length (ft)	0			0	0	275
Storage Lanes	0			0	1	1
Taper Length (ft)	25				25	
Lane Util. Factor	1.00	1.00	1.00	1.00	1.00	1.00
Frt						0.850
Flt Protected					0.950	
Satd. Flow (prot)	0	1863	1863	0	1770	1583
Flt Permitted					0.950	
Satd. Flow (perm)	0	1863	1863	0	1770	1583
Right Turn on Red				Yes		Yes
Satd. Flow (RTOR)						150
Link Speed (mph)		40	40		30	
Link Distance (ft)		225	306		486	
Travel Time (s)		3.8	5.2		11.0	
Peak Hour Factor	0.93	0.93	0.91	0.91	0.92	0.92
Adj. Flow (vph)	0	258	653	0	163	150
Shared Lane Traffic (%)						
Lane Group Flow (vph)	0	258	653	0	163	150
Enter Blocked Intersection	No	No	No	No	No	No
Lane Alignment	Left	Left	Left	Right	Left	Right
Median Width(ft)		4	0		12	
Link Offset(ft)		0	0		0	
Crosswalk Width(ft)		16	16		16	
Two way Left Turn Lane						
Headway Factor	1.00	1.00	1.00	1.00	1.00	1.00
Turning Speed (mph)	15			9	15	9
Number of Detectors		2	2		1	1
Detector Template		Thru	Thru		Left	Right
Leading Detector (ft)		100	100		20	20
Trailing Detector (ft)		0	0		0	0
Detector 1 Position(ft)		0	0		0	0
Detector 1 Size(ft)		6	6		20	20
Detector 1 Type		Cl+Ex	Cl+Ex		Cl+Ex	Cl+Ex
Detector 1 Channel						
Detector 1 Extend (s)		0.0	0.0		0.0	0.0
Detector 1 Queue (s)		0.0	0.0		0.0	0.0
Detector 1 Delay (s)		0.0	0.0		0.0	0.0
Detector 2 Position(ft)		94	94			
Detector 2 Size(ft)		6	6			
Detector 2 Type		Cl+Ex	Cl+Ex			
Detector 2 Channel						
Detector 2 Extend (s)		0.0	0.0			
Turn Type		NA	NA		Perm	Perm
Protected Phases		2	6			
Permitted Phases					4	4

Lanes, Volumes, Timings  
4: Shiloh Road & US 101 SB Off-Ramp

Existing Project Alter. A Conditions  
Timing Plan: A.M. PEAK

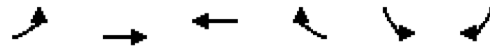

Lane Group	EBL	EBT	WBT	WBR	SBL	SBR
Detector Phase		2	6		4	4
Switch Phase						
Minimum Initial (s)		5.0	5.0		5.0	5.0
Minimum Split (s)		9.0	38.0		9.0	9.0
Total Split (s)		69.0	69.0		21.0	21.0
Total Split (%)		76.7%	76.7%		23.3%	23.3%
Maximum Green (s)		65.0	65.0		17.0	17.0
Yellow Time (s)		3.0	3.0		3.0	3.0
All-Red Time (s)		1.0	1.0		1.0	1.0
Lost Time Adjust (s)		0.0	0.0		0.0	0.0
Total Lost Time (s)		4.0	4.0		4.0	4.0
Lead/Lag						
Lead-Lag Optimize?						
Vehicle Extension (s)		3.0	3.0		3.0	3.0
Recall Mode		None	None		None	None
Walk Time (s)			7.0			
Flash Don't Walk (s)			27.0			
Pedestrian Calls (#/hr)			0			
Act Effct Green (s)		19.9	19.9		9.1	9.1
Actuated g/C Ratio		0.53	0.53		0.24	0.24
v/c Ratio		0.26	0.66		0.38	0.30
Control Delay (s/veh)		5.5	10.1		16.8	5.5
Queue Delay		0.0	0.0		0.0	0.0
Total Delay (s/veh)		5.5	10.1		16.8	5.5
LOS		A	B		B	A
Approach Delay (s/veh)		5.5	10.1		11.4	
Approach LOS		A	B		B	

Intersection Summary

Area Type:	Other
Cycle Length:	90
Actuated Cycle Length:	37.5
Natural Cycle:	50
Control Type:	Actuated-Uncoordinated
Maximum v/c Ratio:	0.66
Intersection Signal Delay (s/veh):	9.4
Intersection LOS:	A
Intersection Capacity Utilization:	60.1%
ICU Level of Service:	B
Analysis Period (min):	15

Splits and Phases: 4: Shiloh Road & US 101 SB Off-Ramp

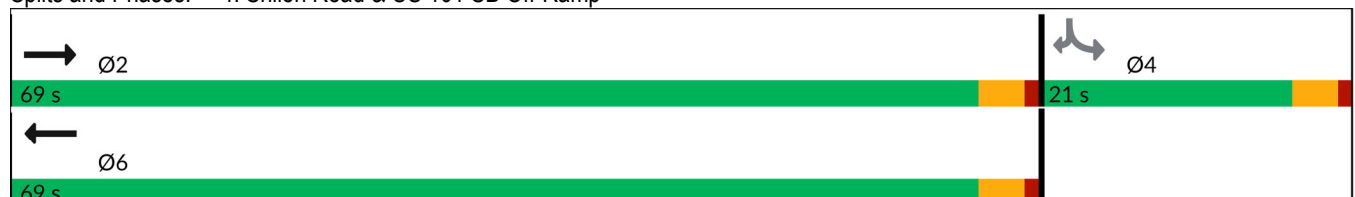

Lanes, Volumes, Timings  
5: Caletti Ave & Shiloh Road

Existing Project Alter. A Conditions  
Timing Plan: A.M. PEAK

	→	↘	↙	←	↖	↗
Lane Group	EBT	EBR	WBL	WBT	NBL	NBR
Lane Configurations	↑↑		↘	↑	↘	↗
Traffic Volume (vph)	532	22	177	557	7	121
Future Volume (vph)	532	22	177	557	7	121
Ideal Flow (vphpl)	1900	1900	1900	1900	1900	1900
Storage Length (ft)		0	68		0	0
Storage Lanes		0	1		1	1
Taper Length (ft)			50		25	
Lane Util. Factor	0.95	0.95	1.00	1.00	1.00	1.00
Frt	0.994					0.850
Flt Protected			0.950		0.950	
Satd. Flow (prot)	3518	0	1770	1863	1770	1583
Flt Permitted			0.950		0.950	
Satd. Flow (perm)	3518	0	1770	1863	1770	1583
Link Speed (mph)	40			40	30	
Link Distance (ft)	1081			184	459	
Travel Time (s)	18.4			3.1	10.4	
Peak Hour Factor	0.96	0.96	0.87	0.87	0.84	0.84
Adj. Flow (vph)	554	23	203	640	8	144
Shared Lane Traffic (%)						
Lane Group Flow (vph)	577	0	203	640	8	144
Enter Blocked Intersection	No	No	No	No	No	No
Lane Alignment	Left	Right	Left	Left	Left	Right
Median Width(ft)	12			12	12	
Link Offset(ft)	0			0	0	
Crosswalk Width(ft)	16			16	16	
Two way Left Turn Lane						
Headway Factor	1.00	1.00	1.00	1.00	1.00	1.00
Turning Speed (mph)		9	15		15	9
Sign Control	Free			Free	Stop	
<b>Intersection Summary</b>						
Area Type:	Other					
Control Type:	Unsignalized					
Intersection Capacity Utilization	39.3%			ICU Level of Service A		
Analysis Period (min)	15					

Lanes, Volumes, Timings  
6: Conde Lane & Shiloh Road

Existing Project Alter. A Conditions  
Timing Plan: A.M. PEAK

Lane Group	EBL	EBT	EBR	WBL	WBT	WBR	NBL	NBT	NBR	SBL	SBT	SBR
Lane Configurations												
Traffic Volume (vph)	25	337	5	9	361	204	4	0	12	205	1	35
Future Volume (vph)	25	337	5	9	361	204	4	0	12	205	1	35
Ideal Flow (vphpl)	1900	1900	1900	1900	1900	1900	1900	1900	1900	1900	1900	1900
Storage Length (ft)	90		0	127		0	0		0	0		40
Storage Lanes	1		0	1		0	0		0	0		1
Taper Length (ft)	70			40			25			25		
Lane Util. Factor	1.00	0.95	0.95	1.00	0.95	0.95	1.00	1.00	1.00	1.00	1.00	1.00
Frt		0.998			0.946			0.899				0.850
Flt Protected	0.950			0.950				0.988			0.953	
Satd. Flow (prot)	1770	3532	0	1770	3348	0	0	1655	0	0	1775	1583
Flt Permitted	0.950			0.950				0.988			0.953	
Satd. Flow (perm)	1770	3532	0	1770	3348	0	0	1655	0	0	1775	1583
Right Turn on Red			Yes			Yes			Yes			No
Satd. Flow (RTOR)		1			114			89				
Link Speed (mph)		40			40			30				35
Link Distance (ft)		815			1081			418				522
Travel Time (s)		13.9			18.4			9.5				10.2
Peak Hour Factor	0.95	0.95	0.95	0.85	0.85	0.85	0.57	0.57	0.57	0.86	0.86	0.86
Adj. Flow (vph)	26	355	5	11	425	240	7	0	21	238	1	41
Shared Lane Traffic (%)												
Lane Group Flow (vph)	26	360	0	11	665	0	0	28	0	0	239	41
Enter Blocked Intersection	No	No	No	No	No	No	No	No	No	No	No	No
Lane Alignment	Left	Left	Right	Left	Left	Right	Left	Left	Right	Left	Left	Right
Median Width(ft)		12			12			0				0
Link Offset(ft)		0			0			0				0
Crosswalk Width(ft)		16			16			16				16
Two way Left Turn Lane												
Headway Factor	1.00	1.00	1.00	1.00	1.00	1.00	1.00	1.00	1.00	1.00	1.00	1.00
Turning Speed (mph)	15		9	15		9	15		9	15		9
Number of Detectors	1	2		1	2		1	2		1	1	1
Detector Template	Left	Thru		Left	Thru		Left	Thru		Left	Thru	Right
Leading Detector (ft)	20	100		20	100		20	100		20	30	20
Trailing Detector (ft)	0	0		0	0		0	0		0	0	0
Detector 1 Position(ft)	0	0		0	0		0	0		0	0	0
Detector 1 Size(ft)	20	6		20	6		20	6		20	30	20
Detector 1 Type	Cl+Ex	Cl+Ex		Cl+Ex	Cl+Ex		Cl+Ex	Cl+Ex		Cl+Ex	Cl+Ex	Cl+Ex
Detector 1 Channel												
Detector 1 Extend (s)	0.0	0.0		0.0	0.0		0.0	0.0		0.0	0.0	0.0
Detector 1 Queue (s)	0.0	0.0		0.0	0.0		0.0	0.0		0.0	0.0	0.0
Detector 1 Delay (s)	0.0	0.0		0.0	0.0		0.0	0.0		0.0	0.0	0.0
Detector 2 Position(ft)		94			94			94				
Detector 2 Size(ft)		6			6			6				
Detector 2 Type		Cl+Ex			Cl+Ex			Cl+Ex				
Detector 2 Channel												
Detector 2 Extend (s)		0.0			0.0			0.0				
Turn Type	Prot	NA		Prot	NA		Split	NA		Split	NA	custom
Protected Phases	5	2		1	6		7	7		4	4	
Permitted Phases												6

Lanes, Volumes, Timings  
6: Conde Lane & Shiloh Road

Existing Project Alter. A Conditions  
Timing Plan: A.M. PEAK

Lane Group	EBL	EBT	EBR	WBL	WBT	WBR	NBL	NBT	NBR	SBL	SBT	SBR
Detector Phase	5	2		1	6		7	7		4	4	6
Switch Phase												
Minimum Initial (s)	8.0	8.0		8.0	8.0		10.0	10.0		11.0	11.0	8.0
Minimum Split (s)	12.0	46.0		12.0	12.0		37.0	37.0		15.0	15.0	12.0
Total Split (s)	13.0	46.0		12.0	45.0		37.0	37.0		15.0	15.0	45.0
Total Split (%)	11.8%	41.8%		10.9%	40.9%		33.6%	33.6%		13.6%	13.6%	40.9%
Maximum Green (s)	9.0	42.0		8.0	41.0		33.0	33.0		11.0	11.0	41.0
Yellow Time (s)	3.0	3.0		3.0	3.0		3.0	3.0		3.0	3.0	3.0
All-Red Time (s)	1.0	1.0		1.0	1.0		1.0	1.0		1.0	1.0	1.0
Lost Time Adjust (s)	0.0	0.0		0.0	0.0		0.0	0.0		0.0	0.0	0.0
Total Lost Time (s)	4.0	4.0		4.0	4.0		4.0	4.0		4.0	4.0	4.0
Lead/Lag	Lead	Lag		Lead	Lag							Lag
Lead-Lag Optimize?	Yes	Yes		Yes	Yes							Yes
Vehicle Extension (s)	3.0	3.0		3.0	3.0		3.0	3.0		3.0	3.0	3.0
Recall Mode	None	None		None	None		None	None		None	None	None
Walk Time (s)		7.0					7.0	7.0				
Flash Don't Walk (s)		35.0					26.0	26.0				
Pedestrian Calls (#/hr)		0					0	0				
Act Effct Green (s)	9.3	16.6		9.3	14.9			11.7			12.9	14.9
Actuated g/C Ratio	0.21	0.38		0.21	0.34			0.27			0.29	0.34
v/c Ratio	0.07	0.27		0.03	0.55			0.06			0.46	0.08
Control Delay (s/veh)	23.8	11.2		23.9	13.3			0.2			25.0	14.1
Queue Delay	0.0	0.0		0.0	0.0			0.0			0.0	0.0
Total Delay (s/veh)	23.8	11.2		23.9	13.3			0.2			25.0	14.1
LOS	C	B		C	B			A			C	B
Approach Delay (s/veh)		12.1			13.5			0.2			23.4	
Approach LOS		B			B			A			C	

Intersection Summary

Area Type:	Other
Cycle Length:	110
Actuated Cycle Length:	44.1
Natural Cycle:	110
Control Type:	Actuated-Uncoordinated
Maximum v/c Ratio:	0.55
Intersection Signal Delay (s/veh):	14.8
Intersection LOS:	B
Intersection Capacity Utilization:	45.5%
ICU Level of Service:	A
Analysis Period (min):	15

Splits and Phases: 6: Conde Lane & Shiloh Road



Lanes, Volumes, Timings  
7: Driveway 1/Gridley Drive & Shiloh Road

Existing Project Alter. A Conditions  
Timing Plan: A.M. PEAK





















Lane Group	EBL	EBT	EBR	WBL	WBT	WBR	NBL	NBT	NBR	SBL	SBT	SBR
Lane Configurations												
Traffic Volume (vph)	8	286	47	0	159	0	33	0	0	1	0	16
Future Volume (vph)	8	286	47	0	159	0	33	0	0	1	0	16
Ideal Flow (vphp)	1900	1900	1900	1900	1900	1900	1900	1900	1900	1900	1900	1900
Storage Length (ft)	0		150	0		0	0		0	0		0
Storage Lanes	0		1	0		0	1		0	0		0
Taper Length (ft)	25			25			25			25		
Lane Util. Factor	1.00	1.00	1.00	1.00	1.00	1.00	1.00	1.00	1.00	1.00	1.00	1.00
Ped Bike Factor												
Frt			0.850									0.871
Flt Protected		0.999					0.950					0.998
Satd. Flow (prot)	0	1861	1583	0	1863	0	1770	1863	0	0	1619	0
Flt Permitted		0.999					0.950					0.998
Satd. Flow (perm)	0	1861	1583	0	1863	0	1770	1863	0	0	1619	0
Link Speed (mph)		40			40			30			30	
Link Distance (ft)		608			2146			248			715	
Travel Time (s)		10.4			36.6			5.6			16.3	
Confl. Bikes (#/hr)			1									
Peak Hour Factor	0.91	0.91	0.91	0.85	0.85	0.85	1.00	1.00	1.00	0.71	0.71	0.71
Adj. Flow (vph)	9	314	52	0	187	0	33	0	0	1	0	23
Shared Lane Traffic (%)												
Lane Group Flow (vph)	0	323	52	0	187	0	33	0	0	0	24	0
Enter Blocked Intersection	No	No	No	No	No	No	No	No	No	No	No	No
Lane Alignment	Left	Left	Right	Left	Left	Right	Left	Left	Right	Left	Left	Right
Median Width(ft)		0			0			12			12	
Link Offset(ft)		0			0			0			0	
Crosswalk Width(ft)		16			16			16			16	
Two way Left Turn Lane												
Headway Factor	1.00	1.00	1.00	1.00	1.00	1.00	1.00	1.00	1.00	1.00	1.00	1.00
Turning Speed (mph)	15		9	15		9	15		9	15		9
Sign Control		Free			Free			Stop			Stop	

Intersection Summary	
Area Type:	Other
Control Type:	Unsignalized
Intersection Capacity Utilization	36.7%
ICU Level of Service	A
Analysis Period (min)	15

Lanes, Volumes, Timings  
8: Old Redwood Hwy & Driveway 2

Existing Project Alter. A Conditions

Timing Plan: A.M. PEAK

												
Lane Group	EBL	EBT	EBR	WBL	WBT	WBR	NBL	NBT	NBR	SBL	SBT	SBR
Lane Configurations												
Traffic Volume (vph)	1	0	0	19	0	31	0	217	28	45	316	0
Future Volume (vph)	1	0	0	19	0	31	0	217	28	45	316	0
Ideal Flow (vphp)	1900	1900	1900	1900	1900	1900	1900	1900	1900	1900	1900	1900
Storage Length (ft)	0		0	0		0	0		100	50		0
Storage Lanes	0		0	1		0	0		1	1		0
Taper Length (ft)	25			25			25			25		
Lane Util. Factor	1.00	1.00	1.00	1.00	1.00	1.00	1.00	1.00	1.00	1.00	1.00	1.00
Ped Bike Factor												
Frt					0.850				0.850			
Flt Protected		0.950		0.950						0.950		
Satd. Flow (prot)	0	1770	0	1770	1583	0	0	1863	1583	1770	1863	0
Flt Permitted		0.950		0.950						0.950		
Satd. Flow (perm)	0	1770	0	1770	1583	0	0	1863	1583	1770	1863	0
Link Speed (mph)		30			30			45			45	
Link Distance (ft)		98			385			520			748	
Travel Time (s)		2.2			8.8			7.9			11.3	
Confl. Peds. (#/hr)									1	1		
Confl. Bikes (#/hr)									1			2
Peak Hour Factor	0.25	0.25	0.25	1.00	1.00	1.00	0.99	0.99	0.99	0.90	0.90	0.90
Adj. Flow (vph)	4	0	0	19	0	31	0	219	28	50	351	0
Shared Lane Traffic (%)												
Lane Group Flow (vph)	0	4	0	19	31	0	0	219	28	50	351	0
Enter Blocked Intersection	No	No	No	No	No	No	No	No	No	No	No	No
Lane Alignment	Left	Left	Right	Left	Left	Right	Left	Left	Right	Left	Left	Right
Median Width(ft)		12			12			12			12	
Link Offset(ft)		0			0			0			0	
Crosswalk Width(ft)		16			16			16			16	
Two way Left Turn Lane												
Headway Factor	1.00	1.00	1.00	1.00	1.00	1.00	1.00	1.00	1.00	1.00	1.00	1.00
Turning Speed (mph)	15		9	15		9	15		9	15		9
Sign Control		Stop			Stop			Free			Free	

Intersection Summary

Area Type:	Other
Control Type:	Unsignalized
Intersection Capacity Utilization	41.4%
Analysis Period (min)	15
	ICU Level of Service A

Lanes, Volumes, Timings  
 9: Driveway 3 & Shiloh Road

Existing Project Alter. A Conditions  
 Timing Plan: A.M. PEAK

	→	↘	↙	←	↖	↗
Lane Group	EBT	EBR	WBL	WBT	NBL	NBR
Lane Configurations	↑	↗		↖	↘	↗
Traffic Volume (vph)	140	145	14	52	101	10
Future Volume (vph)	140	145	14	52	101	10
Ideal Flow (vphpl)	1900	1900	1900	1900	1900	1900
Storage Length (ft)		200	0		0	0
Storage Lanes		1	0		1	1
Taper Length (ft)			25		25	
Lane Util. Factor	1.00	1.00	1.00	1.00	1.00	1.00
Frt		0.850				0.850
Flt Protected				0.990	0.950	
Satd. Flow (prot)	1863	1583	0	1844	1770	1583
Flt Permitted				0.990	0.950	
Satd. Flow (perm)	1863	1583	0	1844	1770	1583
Link Speed (mph)	40			40	30	
Link Distance (ft)	2146			134	402	
Travel Time (s)	36.6			2.3	9.1	
Peak Hour Factor	0.85	0.85	0.81	0.81	1.00	1.00
Adj. Flow (vph)	165	171	17	64	101	10
Shared Lane Traffic (%)						
Lane Group Flow (vph)	165	171	0	81	101	10
Enter Blocked Intersection	No	No	No	No	No	No
Lane Alignment	Left	Right	Left	Left	Left	Right
Median Width(ft)	0			0	12	
Link Offset(ft)	0			0	0	
Crosswalk Width(ft)	16			16	16	
Two way Left Turn Lane						
Headway Factor	1.00	1.00	1.00	1.00	1.00	1.00
Turning Speed (mph)		9	15		15	9
Sign Control	Free			Free	Stop	
<b>Intersection Summary</b>						
Area Type:	Other					
Control Type:	Unsignalized					
Intersection Capacity Utilization	26.5%			ICU Level of Service A		
Analysis Period (min)	15					



Lanes, Volumes, Timings

Existing Project Alter. A Conditions

10: US 101 NB Off Ramp/Lakewood Drive & Old Redwood Highway

Timing Plan: A.M. PEAK



Lane Group	EBL	EBT	EBR	WBL	WBT	WBR	NBL	NBT	NBR	SBL	SBT	SBR
Lane Configurations												
Traffic Volume (vph)	152	177	0	0	459	149	227	221	79	118	0	534
Future Volume (vph)	152	177	0	0	459	149	227	221	79	118	0	534
Ideal Flow (vphpl)	1900	1900	1900	1900	1900	1900	1900	1900	1900	1900	1900	1900
Storage Length (ft)	155		0	0		0	270		150	120		0
Storage Lanes	1		0	0		0	1		1	1		1
Taper Length (ft)	50			25			165			75		
Lane Util. Factor	0.97	1.00	1.00	1.00	0.95	0.95	0.91	0.91	0.95	0.97	1.00	1.00
Ped Bike Factor	1.00				1.00			1.00		1.00		
Flt					0.963			0.966				0.850
Flt Protected	0.950						0.950	0.993		0.950		
Satd. Flow (prot)	3433	1863	0	0	3397	0	1610	3242	0	3433	0	1583
Flt Permitted	0.950						0.950	0.993		0.950		
Satd. Flow (perm)	3431	1863	0	0	3397	0	1610	3242	0	3427	0	1583
Right Turn on Red			Yes			Yes			Yes			Yes
Satd. Flow (RTOR)					50			41				299
Link Speed (mph)		35			35			30				30
Link Distance (ft)		226			617			716				478
Travel Time (s)		4.4			12.0			16.3				10.9
Confl. Peds. (#/hr)	1		1	1		1			2	2		
Confl. Bikes (#/hr)			1			1						
Peak Hour Factor	0.85	0.85	0.85	0.83	0.83	0.83	0.90	0.90	0.90	0.89	0.89	0.89
Adj. Flow (vph)	179	208	0	0	553	180	252	246	88	133	0	600
Shared Lane Traffic (%)							23%					
Lane Group Flow (vph)	179	208	0	0	733	0	194	392	0	133	0	600
Enter Blocked Intersection	No	No	No	No	No	No	No	No	No	No	No	No
Lane Alignment	Left	Left	Right	Left	Left	Right	Left	Left	Right	Left	Left	Right
Median Width(ft)		24			24			24				24
Link Offset(ft)		0			0			0				0
Crosswalk Width(ft)		16			16			16				16
Two way Left Turn Lane												
Headway Factor	1.00	1.00	1.00	1.00	1.00	1.00	1.00	1.00	1.00	1.00	1.00	1.00
Turning Speed (mph)	15		9	15		9	15		9	15		9
Number of Detectors	1	2			2		1	2		1		1
Detector Template	Left	Thru			Thru		Left	Thru		Left		Right
Leading Detector (ft)	20	100			100		20	100		20		20
Trailing Detector (ft)	0	0			0		0	0		0		0
Detector 1 Position(ft)	0	0			0		0	0		0		0
Detector 1 Size(ft)	20	6			6		20	6		20		20
Detector 1 Type	Cl+Ex	Cl+Ex			Cl+Ex		Cl+Ex	Cl+Ex		Cl+Ex		Cl+Ex
Detector 1 Channel												
Detector 1 Extend (s)	0.0	0.0			0.0		0.0	0.0		0.0		0.0
Detector 1 Queue (s)	0.0	0.0			0.0		0.0	0.0		0.0		0.0
Detector 1 Delay (s)	0.0	0.0			0.0		0.0	0.0		0.0		0.0
Detector 2 Position(ft)		94			94			94				
Detector 2 Size(ft)		6			6			6				
Detector 2 Type		Cl+Ex			Cl+Ex			Cl+Ex				
Detector 2 Channel												
Detector 2 Extend (s)		0.0			0.0			0.0				

Lanes, Volumes, Timings

Existing Project Alter. A Conditions

10: US 101 NB Off Ramp/Lakewood Drive & Old Redwood Highway

Timing Plan: A.M. PEAK



Lane Group	EBL	EBT	EBR	WBL	WBT	WBR	NBL	NBT	NBR	SBL	SBT	SBR
Turn Type	Prot	NA			NA		Split	NA		Prot		pm+ov
Protected Phases	5	2			6		8	8		7		5
Permitted Phases												5 8
Detector Phase	5	2			6		8	8		7		5
Switch Phase												
Minimum Initial (s)	7.0	10.0			10.0		10.0	10.0		7.0		7.0
Minimum Split (s)	11.0	32.1			32.1		33.7	33.7		11.0		11.0
Total Split (s)	13.0	45.3			32.3		33.7	33.7		11.0		13.0
Total Split (%)	14.4%	50.3%			35.9%		37.4%	37.4%		12.2%		14.4%
Maximum Green (s)	9.0	40.2			27.2		29.0	29.0		7.0		9.0
Yellow Time (s)	3.0	4.1			4.1		3.7	3.7		3.0		3.0
All-Red Time (s)	1.0	1.0			1.0		1.0	1.0		1.0		1.0
Lost Time Adjust (s)	0.0	0.0			0.0		0.0	0.0		0.0		0.0
Total Lost Time (s)	4.0	5.1			5.1		4.7	4.7		4.0		4.0
Lead/Lag	Lead				Lag		Lag	Lag		Lead		Lead
Lead-Lag Optimize?	Yes				Yes		Yes	Yes		Yes		Yes
Vehicle Extension (s)	3.0	3.0			3.0		3.0	3.0		3.0		3.0
Recall Mode	None	Max			Max		None	None		None		None
Walk Time (s)		7.0			7.0		7.0	7.0				
Flash Don't Walk (s)		20.0			17.0		22.0	22.0				
Pedestrian Calls (#/hr)		0			0		0	0				
Act Effct Green (s)	8.4	40.3			27.9		15.8	15.8		7.0		28.9
Actuated g/C Ratio	0.11	0.52			0.36		0.21	0.21		0.09		0.38
v/c Ratio	0.48	0.21			0.58		0.59	0.56		0.42		0.77
Control Delay (s/veh)	37.6	11.6			21.6		35.0	27.4		38.9		17.2
Queue Delay	0.0	0.0			0.0		0.0	0.0		0.0		0.0
Total Delay (s/veh)	37.6	11.6			21.6		35.0	27.4		38.9		17.2
LOS	D	B			C		D	C		D		B
Approach Delay (s/veh)		23.6			21.6			29.9				21.2
Approach LOS		C			C			C				C

Intersection Summary

Area Type: Other  
 Cycle Length: 90  
 Actuated Cycle Length: 77  
 Natural Cycle: 90  
 Control Type: Actuated-Uncoordinated  
 Maximum v/c Ratio: 0.77  
 Intersection Signal Delay (s/veh): 23.8  
 Intersection LOS: C  
 Intersection Capacity Utilization 75.7%  
 ICU Level of Service D  
 Analysis Period (min) 15

Splits and Phases: 10: US 101 NB Off Ramp/Lakewood Drive & Old Redwood Highway

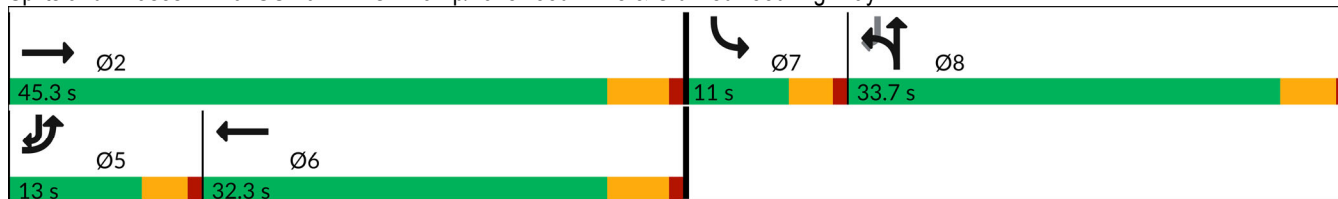

Lanes, Volumes, Timings  
 11: Old Redwood Highway & US 101 NB On Ramp

Existing Project Alter. A Conditions

Timing Plan: A.M. PEAK

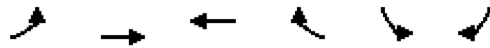

Lane Group	EBL	EBT	WBT	WBR	SBL	SBR
Lane Configurations	↶	↷	↶	↷		
Traffic Volume (vph)	86	327	1012	190	0	0
Future Volume (vph)	86	327	1012	190	0	0
Ideal Flow (vphpl)	1900	1900	1900	1900	1900	1900
Storage Length (ft)	245			0	0	0
Storage Lanes	1			0	0	0
Taper Length (ft)	50				25	
Lane Util. Factor	1.00	0.95	0.95	0.95	1.00	1.00
Ped Bike Factor						
Frt			0.976			
Flt Protected	0.950					
Satd. Flow (prot)	1770	3539	3454	0	0	0
Flt Permitted	0.950					
Satd. Flow (perm)	1770	3539	3454	0	0	0
Link Speed (mph)		35	35		30	
Link Distance (ft)		531	226		299	
Travel Time (s)		10.3	4.4		6.8	
Confl. Peds. (#/hr)	9					
Confl. Bikes (#/hr)				1		
Peak Hour Factor	0.81	0.81	0.89	0.89	0.25	0.25
Adj. Flow (vph)	106	404	1137	213	0	0
Shared Lane Traffic (%)						
Lane Group Flow (vph)	106	404	1350	0	0	0
Enter Blocked Intersection	No	No	No	No	No	No
Lane Alignment	Left	Left	Left	Right	Left	Right
Median Width(ft)		12	12		0	
Link Offset(ft)		0	0		0	
Crosswalk Width(ft)		16	16		16	
Two way Left Turn Lane						
Headway Factor	1.00	1.00	1.00	1.00	1.00	1.00
Turning Speed (mph)	15			9	15	9
Sign Control		Free	Free		Free	

Intersection Summary

Area Type:	Other
Control Type:	Unsignalized
Intersection Capacity Utilization	70.8%
Analysis Period (min)	15
	ICU Level of Service C

Lanes, Volumes, Timings

Existing Project Alter. A Conditions

12: US 101 SB On Ramp/US 101 SB Off Ramp & Old Redwood Highway

Timing Plan: A.M. PEAK



Lane Group	EBL	EBT	EBR	WBL	WBT	WBR	NBL	NBT	NBR	SBL	SBT	SBR
Lane Configurations		↑↑	↗	↘	↑↑					↘	↕	
Traffic Volume (vph)	0	298	296	513	504	0	0	0	0	120	1	65
Future Volume (vph)	0	298	296	513	504	0	0	0	0	120	1	65
Ideal Flow (vphpl)	1900	1900	1900	1900	1900	1900	1900	1900	1900	1900	1900	1900
Storage Length (ft)	0		0	250		0	0		0	420		0
Storage Lanes	0		1	0		0	0		0	1		0
Taper Length (ft)	25			165			25			75		
Lane Util. Factor	1.00	0.95	1.00	1.00	0.95	1.00	1.00	1.00	1.00	0.95	0.95	1.00
Ped Bike Factor			0.98	1.00								
Frt			0.850								0.890	
Flt Protected				0.950						0.950	0.987	
Satd. Flow (prot)	0	3539	1583	1770	3539	0	0	0	0	1681	1554	0
Flt Permitted				0.950						0.950	0.987	
Satd. Flow (perm)	0	3539	1558	1767	3539	0	0	0	0	1681	1554	0
Right Turn on Red			Yes			Yes			Yes			Yes
Satd. Flow (RTOR)			322								80	
Link Speed (mph)		35			35			30			30	
Link Distance (ft)		423			531			621			831	
Travel Time (s)		8.2			10.3			14.1			18.9	
Confl. Peds. (#/hr)	10		3	3		10						
Confl. Bikes (#/hr)			2									
Peak Hour Factor	0.92	0.92	0.92	0.89	0.89	0.89	0.25	0.25	0.25	0.81	0.81	0.81
Adj. Flow (vph)	0	324	322	576	566	0	0	0	0	148	1	80
Shared Lane Traffic (%)										19%		
Lane Group Flow (vph)	0	324	322	576	566	0	0	0	0	120	109	0
Enter Blocked Intersection	No	No	No	No	No	No	No	No	No	No	No	No
Lane Alignment	Left	Left	Right	Left	Left	Right	Left	Left	Right	Left	Left	Right
Median Width(ft)		24			24			12			12	
Link Offset(ft)		0			0			0			0	
Crosswalk Width(ft)		16			16			16			16	
Two way Left Turn Lane												
Headway Factor	1.00	1.00	1.00	1.00	1.00	1.00	1.00	1.00	1.00	1.00	1.00	1.00
Turning Speed (mph)	15		9	15		9	15		9	15		9
Number of Detectors		2	1	1	2					1	2	
Detector Template		Thru	Right	Left	Thru					Left	Thru	
Leading Detector (ft)		100	20	20	100					20	100	
Trailing Detector (ft)		0	0	0	0					0	0	
Detector 1 Position(ft)		0	0	0	0					0	0	
Detector 1 Size(ft)		6	20	20	6					20	6	
Detector 1 Type		Cl+Ex	Cl+Ex	Cl+Ex	Cl+Ex					Cl+Ex	Cl+Ex	
Detector 1 Channel												
Detector 1 Extend (s)		0.0	0.0	0.0	0.0					0.0	0.0	
Detector 1 Queue (s)		0.0	0.0	0.0	0.0					0.0	0.0	
Detector 1 Delay (s)		0.0	0.0	0.0	0.0					0.0	0.0	
Detector 2 Position(ft)		94			94							94
Detector 2 Size(ft)		6			6							6
Detector 2 Type		Cl+Ex			Cl+Ex							Cl+Ex
Detector 2 Channel												
Detector 2 Extend (s)		0.0			0.0							0.0

Lanes, Volumes, Timings

Existing Project Alter. A Conditions

12: US 101 SB On Ramp/US 101 SB Off Ramp & Old Redwood Highway

Timing Plan: A.M. PEAK



Lane Group	EBL	EBT	EBR	WBL	WBT	WBR	NBL	NBT	NBR	SBL	SBT	SBR
Turn Type		NA	Perm	Prot	NA					Perm	NA	
Protected Phases		6		5	2						8	
Permitted Phases			6							8		
Detector Phase		6	6	5	2					8	8	
Switch Phase												
Minimum Initial (s)		10.0	10.0	7.0	10.0					10.0	10.0	
Minimum Split (s)		32.1	32.1	11.0	38.1					14.7	14.7	
Total Split (s)		32.3	32.3	33.0	65.3					14.7	14.7	
Total Split (%)		40.4%	40.4%	41.3%	81.6%					18.4%	18.4%	
Maximum Green (s)		27.2	27.2	29.0	60.2					10.0	10.0	
Yellow Time (s)		4.1	4.1	3.0	4.1					3.7	3.7	
All-Red Time (s)		1.0	1.0	1.0	1.0					1.0	1.0	
Lost Time Adjust (s)		0.0	0.0	0.0	0.0					0.0	0.0	
Total Lost Time (s)		5.1	5.1	4.0	5.1					4.7	4.7	
Lead/Lag		Lag	Lag	Lead								
Lead-Lag Optimize?		Yes	Yes	Yes								
Vehicle Extension (s)		3.0	3.0	3.0	3.0					3.0	3.0	
Recall Mode		Max	Max	None	Max					None	None	
Walk Time (s)		7.0	7.0		7.0							
Flash Don't Walk (s)		20.0	20.0		25.0							
Pedestrian Calls (#/hr)		0	0		0							
Act Effct Green (s)		28.1	28.1	28.1	60.2					10.0	10.0	
Actuated g/C Ratio		0.35	0.35	0.35	0.75					0.13	0.13	
v/c Ratio		0.26	0.43	0.93	0.21					0.57	0.41	
Control Delay (s/veh)		19.6	4.4	48.8	3.1					44.7	17.5	
Queue Delay		0.0	0.0	0.0	0.0					0.0	0.0	
Total Delay (s/veh)		19.6	4.4	48.8	3.1					44.7	17.5	
LOS		B	A	D	A					D	B	
Approach Delay (s/veh)		12.0			26.2						31.8	
Approach LOS		B			C						C	

Intersection Summary





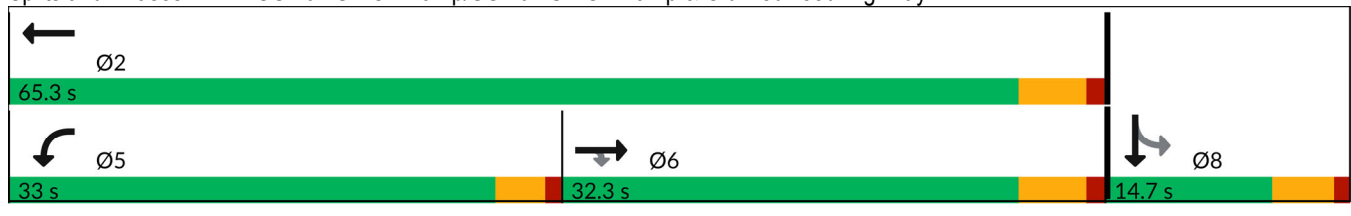

















Area Type:	Other
Cycle Length:	80
Actuated Cycle Length:	80
Natural Cycle:	80
Control Type:	Actuated-Uncoordinated
Maximum v/c Ratio:	0.93
Intersection Signal Delay (s/veh):	22.3
Intersection LOS:	C
Intersection Capacity Utilization:	70.8%
ICU Level of Service:	C
Analysis Period (min):	15

Splits and Phases: 12: US 101 SB On Ramp/US 101 SB Off Ramp & Old Redwood Highway



Lanes, Volumes, Timings  
1: Old Redwood Hwy & Shiloh Road

Existing Project Alter. A Conditions  
Timing Plan: P.M. Peak

												
Lane Group	EBL	EBT	EBR	WBL	WBT	WBR	NBL	NBT	NBR	SBL	SBT	SBR
Lane Configurations												
Traffic Volume (vph)	241	516	260	37	381	55	209	347	21	80	247	146
Future Volume (vph)	241	516	260	37	381	55	209	347	21	80	247	146
Ideal Flow (vphpl)	1900	1900	1900	1900	1900	1900	1900	1900	1900	1900	1900	1900
Storage Length (ft)	375		140	0		50	200		98	130		93
Storage Lanes	1		1	0		1	1		1	1		1
Taper Length (ft)	50			25			60			93		
Lane Util. Factor	1.00	1.00	1.00	1.00	1.00	1.00	1.00	1.00	1.00	1.00	1.00	1.00
Ped Bike Factor	1.00					0.98	1.00		0.98			0.97
Frt			0.850			0.850			0.850			0.850
Flt Protected	0.950				0.996		0.950			0.950		
Satd. Flow (prot)	1770	1863	1583	0	1855	1583	1770	1863	1583	1770	1863	1583
Flt Permitted	0.950				0.996		0.950			0.950		
Satd. Flow (perm)	1768	1863	1583	0	1855	1549	1767	1863	1546	1770	1863	1542
Right Turn on Red			Yes			Yes			Yes			Yes
Satd. Flow (RTOR)			115			105			77			105
Link Speed (mph)		40			40			45			40	
Link Distance (ft)		1789			608			748			775	
Travel Time (s)		30.5			10.4			11.3			13.2	
Confl. Peds. (#/hr)	1						1	1				1
Confl. Bikes (#/hr)									3			3
Peak Hour Factor	0.97	0.97	0.97	0.91	0.91	0.91	0.93	0.93	0.93	0.93	0.93	0.93
Adj. Flow (vph)	248	532	268	41	419	60	225	373	23	86	266	157
Shared Lane Traffic (%)												
Lane Group Flow (vph)	248	532	268	0	460	60	225	373	23	86	266	157
Enter Blocked Intersection	No	No	No	No	No	No	No	No	No	No	No	No
Lane Alignment	Left	Left	Right	Left	Left	Right	Left	Left	Right	Left	Left	Right
Median Width(ft)		12			12			12			12	
Link Offset(ft)		0			0			0			0	
Crosswalk Width(ft)		16			16			16			16	
Two way Left Turn Lane												
Headway Factor	1.00	1.00	1.00	1.00	1.00	1.00	1.00	1.00	1.00	1.00	1.00	1.00
Turning Speed (mph)	15		9	15		9	15		9	15		9
Number of Detectors	1	2	1	1	2	1	1	2	1	1	2	1
Detector Template	Left	Thru	Right	Left	Thru	Right	Left	Thru	Right	Left	Thru	Right
Leading Detector (ft)	20	100	20	20	100	20	20	100	20	20	100	20
Trailing Detector (ft)	0	0	0	0	0	0	0	0	0	0	0	0
Detector 1 Position(ft)	0	0	0	0	0	0	0	0	0	0	0	0
Detector 1 Size(ft)	20	6	20	20	6	20	20	6	20	20	6	20
Detector 1 Type	Cl+Ex	Cl+Ex	Cl+Ex	Cl+Ex	Cl+Ex	Cl+Ex	Cl+Ex	Cl+Ex	Cl+Ex	Cl+Ex	Cl+Ex	Cl+Ex
Detector 1 Channel												
Detector 1 Extend (s)	0.0	0.0	0.0	0.0	0.0	0.0	0.0	0.0	0.0	0.0	0.0	0.0
Detector 1 Queue (s)	0.0	0.0	0.0	0.0	0.0	0.0	0.0	0.0	0.0	0.0	0.0	0.0
Detector 1 Delay (s)	0.0	0.0	0.0	0.0	0.0	0.0	0.0	0.0	0.0	0.0	0.0	0.0
Detector 2 Position(ft)		94			94			94			94	
Detector 2 Size(ft)		6			6			6			6	
Detector 2 Type		Cl+Ex			Cl+Ex			Cl+Ex			Cl+Ex	
Detector 2 Channel												
Detector 2 Extend (s)		0.0			0.0			0.0			0.0	

Lanes, Volumes, Timings  
1: Old Redwood Hwy & Shiloh Road

Existing Project Alter. A Conditions  
Timing Plan: P.M. Peak



Lane Group	EBL	EBT	EBR	WBL	WBT	WBR	NBL	NBT	NBR	SBL	SBT	SBR
Turn Type	Split	NA	Perm	Split	NA	Perm	Prot	NA	Perm	Prot	NA	Perm
Protected Phases	2	2		6	6		3	8		7	4	
Permitted Phases			2			6			8			4
Detector Phase	2	2	2	6	6	6	3	8	8	7	4	4
Switch Phase												
Minimum Initial (s)	5.0	5.0	5.0	5.0	5.0	5.0	5.0	5.0	5.0	5.0	5.0	5.0
Minimum Split (s)	34.5	34.5	34.5	42.5	42.5	42.5	8.5	46.5	46.5	8.5	39.5	39.5
Total Split (s)	35.0	35.0	35.0	42.5	42.5	42.5	18.0	48.0	48.0	9.5	39.5	39.5
Total Split (%)	25.9%	25.9%	25.9%	31.5%	31.5%	31.5%	13.3%	35.6%	35.6%	7.0%	29.3%	29.3%
Maximum Green (s)	30.5	30.5	30.5	38.0	38.0	38.0	14.5	43.5	43.5	6.0	35.0	35.0
Yellow Time (s)	3.5	3.5	3.5	3.5	3.5	3.5	3.0	3.5	3.5	3.0	3.5	3.5
All-Red Time (s)	1.0	1.0	1.0	1.0	1.0	1.0	0.5	1.0	1.0	0.5	1.0	1.0
Lost Time Adjust (s)	0.0	0.0	0.0		0.0	0.0	0.0	0.0	0.0	0.0	0.0	0.0
Total Lost Time (s)	4.5	4.5	4.5		4.5	4.5	3.5	4.5	4.5	3.5	4.5	4.5
Lead/Lag	Lead	Lead	Lead	Lag	Lag	Lag	Lead	Lag	Lag	Lead	Lag	Lag
Lead-Lag Optimize?	Yes	Yes	Yes	Yes	Yes	Yes	Yes	Yes	Yes	Yes	Yes	Yes
Vehicle Extension (s)	3.0	3.0	3.0	3.0	3.0	3.0	3.0	3.0	3.0	3.0	3.0	3.0
Recall Mode	None	None	None	None	None	None	None	None	None	None	None	None
Walk Time (s)	7.0	7.0	7.0	7.0	7.0	7.0		7.0	7.0		7.0	7.0
Flash Dont Walk (s)	23.0	23.0	23.0	31.0	31.0	31.0		35.0	35.0		28.0	28.0
Pedestrian Calls (#/hr)	0	0	0	0	0	0		0	0		0	0
Act Effct Green (s)	30.8	30.8	30.8		33.3	33.3	14.6	31.0	31.0	6.1	22.4	22.4
Actuated g/C Ratio	0.26	0.26	0.26		0.28	0.28	0.12	0.26	0.26	0.05	0.19	0.19
v/c Ratio	0.54	1.10	0.54		0.88	0.12	1.03	0.77	0.05	0.96	0.76	0.42
Control Delay	45.2	112.3	27.4		60.4	1.3	121.0	51.9	0.2	141.0	59.9	19.1
Queue Delay	0.0	0.0	0.0		0.0	0.0	0.0	0.0	0.0	0.0	0.0	0.0
Total Delay	45.2	112.3	27.4		60.4	1.3	121.0	51.9	0.2	141.0	59.9	19.1
LOS	D	F	C		E	A	F	D	A	F	E	B
Approach Delay		74.7			53.6			75.0			61.0	
Approach LOS		E			D			E			E	

Intersection Summary

Area Type:	Other
Cycle Length:	135
Actuated Cycle Length:	118.3
Natural Cycle:	145
Control Type:	Actuated-Uncoordinated
Maximum v/c Ratio:	1.10
Intersection Signal Delay:	68.1
Intersection LOS:	E
Intersection Capacity Utilization:	89.3%
ICU Level of Service:	E
Analysis Period (min):	15

Splits and Phases: 1: Old Redwood Hwy & Shiloh Road



Lanes, Volumes, Timings  
2: Shiloh Road & Hembree Ln

Existing Project Alter. A Conditions  
Timing Plan: P.M. Peak

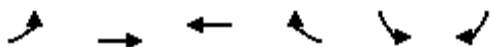

Lane Group	EBL	EBT	WBT	WBR	SBL	SBR
Lane Configurations	↙↘	↑	↕↔		↙	↘
Traffic Volume (vph)	615	866	620	141	170	491
Future Volume (vph)	615	866	620	141	170	491
Ideal Flow (vphp)	1900	1900	1900	1900	1900	1900
Storage Length (ft)	0			130	0	0
Storage Lanes	2			1	1	1
Taper Length (ft)	25				25	
Lane Util. Factor	0.97	1.00	0.95	0.95	1.00	1.00
Ped Bike Factor	1.00		1.00			
Frt			0.972			0.850
Flt Protected	0.950				0.950	
Satd. Flow (prot)	3433	1863	3432	0	1770	1583
Flt Permitted	0.950				0.950	
Satd. Flow (perm)	3431	1863	3432	0	1770	1583
Right Turn on Red				Yes		Yes
Satd. Flow (RTOR)			39			130
Link Speed (mph)		40	40		35	
Link Distance (ft)		302	1789		381	
Travel Time (s)		5.1	30.5		7.4	
Confl. Peds. (#/hr)	2			2		
Peak Hour Factor	0.94	0.94	0.87	0.87	0.95	0.95
Adj. Flow (vph)	654	921	713	162	179	517
Shared Lane Traffic (%)						
Lane Group Flow (vph)	654	921	875	0	179	517
Enter Blocked Intersection	No	No	No	No	No	No
Lane Alignment	Left	Left	Left	Right	Left	Right
Median Width(ft)		24	24		12	
Link Offset(ft)		0	0		0	
Crosswalk Width(ft)		16	16		16	
Two way Left Turn Lane						
Headway Factor	1.00	1.00	1.00	1.00	1.00	1.00
Turning Speed (mph)	15			9	15	9
Number of Detectors	1	2	2		1	1
Detector Template	Left	Thru	Thru		Left	Right
Leading Detector (ft)	20	100	100		20	20
Trailing Detector (ft)	0	0	0		0	0
Detector 1 Position(ft)	0	0	0		0	0
Detector 1 Size(ft)	20	6	6		20	20
Detector 1 Type	Cl+Ex	Cl+Ex	Cl+Ex		Cl+Ex	Cl+Ex
Detector 1 Channel						
Detector 1 Extend (s)	0.0	0.0	0.0		0.0	0.0
Detector 1 Queue (s)	0.0	0.0	0.0		0.0	0.0
Detector 1 Delay (s)	0.0	0.0	0.0		0.0	0.0
Detector 2 Position(ft)		94	94			
Detector 2 Size(ft)		6	6			
Detector 2 Type		Cl+Ex	Cl+Ex			
Detector 2 Channel						
Detector 2 Extend (s)		0.0	0.0			
Turn Type	Prot	NA	NA		Perm	pm+ov



Lanes, Volumes, Timings  
2: Shiloh Road & Hembree Ln

Existing Project Alter. A Conditions  
Timing Plan: P.M. Peak



Lane Group	EBL	EBT	WBT	WBR	SBL	SBR
Protected Phases	5	2	6			5
Permitted Phases					4	4 5
Detector Phase	5	2	6		4	5
Switch Phase						
Minimum Initial (s)	3.0	5.0	5.0		5.0	3.0
Minimum Split (s)	7.0	9.0	43.0		9.0	7.0
Total Split (s)	29.0	73.0	44.0		17.0	29.0
Total Split (%)	32.2%	81.1%	48.9%		18.9%	32.2%
Maximum Green (s)	25.0	69.0	40.0		13.0	25.0
Yellow Time (s)	3.0	3.0	3.0		3.0	3.0
All-Red Time (s)	1.0	1.0	1.0		1.0	1.0
Lost Time Adjust (s)	0.0	0.0	0.0		0.0	0.0
Total Lost Time (s)	4.0	4.0	4.0		4.0	4.0
Lead/Lag	Lead		Lag			Lead
Lead-Lag Optimize?	Yes		Yes			Yes
Vehicle Extension (s)	3.0	3.0	3.0		3.0	3.0
Recall Mode	None	None	None		None	None
Walk Time (s)			7.0			
Flash Dont Walk (s)			32.0			
Pedestrian Calls (#/hr)			0			
Act Effct Green (s)	19.3	47.5	24.0		11.5	35.0
Actuated g/C Ratio	0.29	0.71	0.36		0.17	0.52
v/c Ratio	0.67	0.70	0.70		0.59	0.58
Control Delay	25.9	9.1	21.5		38.0	12.1
Queue Delay	0.0	0.1	0.0		0.0	0.0
Total Delay	25.9	9.2	21.5		38.0	12.1
LOS	C	A	C		D	B
Approach Delay		16.1	21.5		18.8	
Approach LOS		B	C		B	

Intersection Summary

Area Type:	Other
Cycle Length:	90
Actuated Cycle Length:	67.3
Natural Cycle:	75
Control Type:	Actuated-Uncoordinated
Maximum v/c Ratio:	0.70
Intersection Signal Delay:	18.2
Intersection LOS:	B
Intersection Capacity Utilization:	61.7%
ICU Level of Service:	B
Analysis Period (min):	15

Splits and Phases: 2: Shiloh Road & Hembree Ln



Lanes, Volumes, Timings  
3: US 101 NB Off-Ramp & Shiloh Road

Existing Project Alter. A Conditions  
Timing Plan: P.M. Peak



Lane Group	EBT	EBR	WBL	WBT	NBL	NBR
Lane Configurations	↑↑			↑	↘	↗↗
Traffic Volume (vph)	561	0	0	762	526	925
Future Volume (vph)	561	0	0	762	526	925
Ideal Flow (vphpl)	1900	1900	1900	1900	1900	1900
Storage Length (ft)		0	0		0	265
Storage Lanes		0	0		1	2
Taper Length (ft)			25		25	
Lane Util. Factor	0.95	1.00	1.00	1.00	1.00	0.88
Frt						0.850
Flt Protected					0.950	
Satd. Flow (prot)	3539	0	0	1863	1770	2787
Flt Permitted					0.950	
Satd. Flow (perm)	3539	0	0	1863	1770	2787
Right Turn on Red		Yes				Yes
Satd. Flow (RTOR)						349
Link Speed (mph)	40			40	30	
Link Distance (ft)	186			371	769	
Travel Time (s)	3.2			6.3	17.5	
Peak Hour Factor	0.94	0.94	0.97	0.97	0.90	0.90
Adj. Flow (vph)	597	0	0	786	584	1028
Shared Lane Traffic (%)						
Lane Group Flow (vph)	597	0	0	786	584	1028
Enter Blocked Intersection	No	No	No	No	No	No
Lane Alignment	Left	Right	Left	Left	Left	Right
Median Width(ft)	0			0	12	
Link Offset(ft)	0			0	0	
Crosswalk Width(ft)	16			16	16	
Two way Left Turn Lane						
Headway Factor	1.00	1.00	1.00	1.00	1.00	1.00
Turning Speed (mph)		9	15		15	9
Number of Detectors	2			2	1	1
Detector Template	Thru			Thru	Left	Right
Leading Detector (ft)	100			100	20	20
Trailing Detector (ft)	0			0	0	0
Detector 1 Position(ft)	0			0	0	0
Detector 1 Size(ft)	6			6	20	20
Detector 1 Type	Cl+Ex			Cl+Ex	Cl+Ex	Cl+Ex
Detector 1 Channel						
Detector 1 Extend (s)	0.0			0.0	0.0	0.0
Detector 1 Queue (s)	0.0			0.0	0.0	0.0
Detector 1 Delay (s)	0.0			0.0	0.0	0.0
Detector 2 Position(ft)	94			94		
Detector 2 Size(ft)	6			6		
Detector 2 Type	Cl+Ex			Cl+Ex		
Detector 2 Channel						
Detector 2 Extend (s)	0.0			0.0		
Turn Type	NA			NA	Prot	Perm
Protected Phases	2			6	8	
Permitted Phases						8

Lanes, Volumes, Timings  
 3: US 101 NB Off-Ramp & Shiloh Road

Existing Project Alter. A Conditions  
 Timing Plan: P.M. Peak



Lane Group	EBT	EBR	WBL	WBT	NBL	NBR
Detector Phase	2			6	8	8
Switch Phase						
Minimum Initial (s)	5.0			5.0	5.0	5.0
Minimum Split (s)	9.0			9.0	9.0	9.0
Total Split (s)	37.0			37.0	35.0	35.0
Total Split (%)	51.4%			51.4%	48.6%	48.6%
Maximum Green (s)	33.0			33.0	31.0	31.0
Yellow Time (s)	3.0			3.0	3.0	3.0
All-Red Time (s)	1.0			1.0	1.0	1.0
Lost Time Adjust (s)	0.0			0.0	0.0	0.0
Total Lost Time (s)	4.0			4.0	4.0	4.0
Lead/Lag						
Lead-Lag Optimize?						
Vehicle Extension (s)	3.0			3.0	3.0	3.0
Recall Mode	None			None	None	None
Act Effect Green (s)	30.8			30.8	27.1	27.1
Actuated g/C Ratio	0.47			0.47	0.41	0.41
v/c Ratio	0.36			0.91	0.80	0.76
Control Delay	12.7			34.1	27.7	15.2
Queue Delay	0.0			0.0	0.0	0.0
Total Delay	12.7			34.1	27.7	15.2
LOS	B			C	C	B
Approach Delay	12.7			34.1	19.7	
Approach LOS	B			C	B	

Intersection Summary

Area Type: Other  
 Cycle Length: 72  
 Actuated Cycle Length: 66.1  
 Natural Cycle: 60  
 Control Type: Actuated-Uncoordinated  
 Maximum v/c Ratio: 0.91  
 Intersection Signal Delay: 22.1  
 Intersection LOS: C  
 Intersection Capacity Utilization 130.2%  
 ICU Level of Service H  
 Analysis Period (min) 15

Splits and Phases: 3: US 101 NB Off-Ramp & Shiloh Road

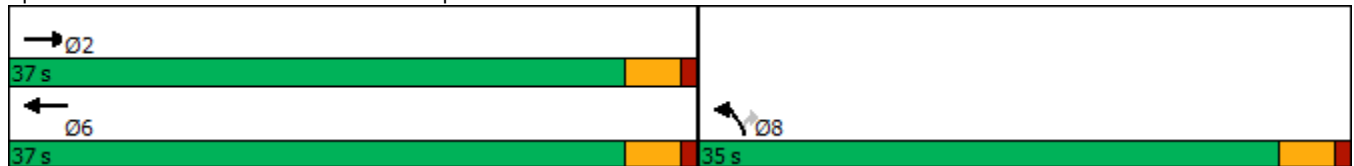

Lanes, Volumes, Timings  
4: Shiloh Road & US 101 SB Off-Ramp

Existing Project Alter. A Conditions  
Timing Plan: P.M. Peak



Lane Group	EBL	EBT	WBT	WBR	SBL	SBR
Lane Configurations		↑	↑		↓	↓
Traffic Volume (vph)	0	458	640	0	299	110
Future Volume (vph)	0	458	640	0	299	110
Ideal Flow (vphp)	1900	1900	1900	1900	1900	1900
Storage Length (ft)	0			0	0	275
Storage Lanes	0			0	1	1
Taper Length (ft)	25				25	
Lane Util. Factor	1.00	1.00	1.00	1.00	1.00	1.00
Ped Bike Factor						0.98
Frt						0.850
Flt Protected					0.950	
Satd. Flow (prot)	0	1863	1863	0	1770	1583
Flt Permitted					0.950	
Satd. Flow (perm)	0	1863	1863	0	1770	1548
Right Turn on Red				Yes		Yes
Satd. Flow (RTOR)						118
Link Speed (mph)		40	40		30	
Link Distance (ft)		225	306		486	
Travel Time (s)		3.8	5.2		11.0	
Confl. Peds. (#/hr)						1
Peak Hour Factor	0.89	0.89	0.96	0.96	0.93	0.93
Adj. Flow (vph)	0	515	667	0	322	118
Shared Lane Traffic (%)						
Lane Group Flow (vph)	0	515	667	0	322	118
Enter Blocked Intersection	No	No	No	No	No	No
Lane Alignment	Left	Left	Left	Right	Left	Right
Median Width(ft)		4	0		12	
Link Offset(ft)		0	0		0	
Crosswalk Width(ft)		16	16		16	
Two way Left Turn Lane						
Headway Factor	1.00	1.00	1.00	1.00	1.00	1.00
Turning Speed (mph)	15			9	15	9
Number of Detectors		2	2		1	1
Detector Template		Thru	Thru		Left	Right
Leading Detector (ft)		100	100		20	20
Trailing Detector (ft)		0	0		0	0
Detector 1 Position(ft)		0	0		0	0
Detector 1 Size(ft)		6	6		20	20
Detector 1 Type		Cl+Ex	Cl+Ex		Cl+Ex	Cl+Ex
Detector 1 Channel						
Detector 1 Extend (s)		0.0	0.0		0.0	0.0
Detector 1 Queue (s)		0.0	0.0		0.0	0.0
Detector 1 Delay (s)		0.0	0.0		0.0	0.0
Detector 2 Position(ft)		94	94			
Detector 2 Size(ft)		6	6			
Detector 2 Type		Cl+Ex	Cl+Ex			
Detector 2 Channel						
Detector 2 Extend (s)		0.0	0.0			
Turn Type		NA	NA		Perm	Perm

Lanes, Volumes, Timings  
4: Shiloh Road & US 101 SB Off-Ramp

Existing Project Alter. A Conditions  
Timing Plan: P.M. Peak



Lane Group	EBL	EBT	WBT	WBR	SBL	SBR
Protected Phases		2	6			
Permitted Phases					4	4
Detector Phase		2	6		4	4
Switch Phase						
Minimum Initial (s)		5.0	5.0		5.0	5.0
Minimum Split (s)		9.0	38.0		9.0	9.0
Total Split (s)		69.0	69.0		21.0	21.0
Total Split (%)		76.7%	76.7%		23.3%	23.3%
Maximum Green (s)		65.0	65.0		17.0	17.0
Yellow Time (s)		3.0	3.0		3.0	3.0
All-Red Time (s)		1.0	1.0		1.0	1.0
Lost Time Adjust (s)		0.0	0.0		0.0	0.0
Total Lost Time (s)		4.0	4.0		4.0	4.0
Lead/Lag						
Lead-Lag Optimize?						
Vehicle Extension (s)		3.0	3.0		3.0	3.0
Recall Mode		None	None		None	None
Walk Time (s)			7.0			
Flash Dont Walk (s)			27.0			
Pedestrian Calls (#/hr)			0			
Act Effct Green (s)		22.2	22.2		16.2	16.2
Actuated g/C Ratio		0.48	0.48		0.35	0.35
v/c Ratio		0.58	0.75		0.53	0.19
Control Delay		11.5	15.8		17.6	4.6
Queue Delay		0.0	0.0		0.0	0.0
Total Delay		11.5	15.8		17.6	4.6
LOS		B	B		B	A
Approach Delay		11.5	15.8		14.1	
Approach LOS		B	B		B	

Intersection Summary

Area Type:	Other
Cycle Length:	90
Actuated Cycle Length:	46.6
Natural Cycle:	55
Control Type:	Actuated-Uncoordinated
Maximum v/c Ratio:	0.75
Intersection Signal Delay:	14.0
Intersection LOS:	B
Intersection Capacity Utilization:	120.5%
ICU Level of Service:	H
Analysis Period (min):	15

Splits and Phases: 4: Shiloh Road & US 101 SB Off-Ramp





















Lanes, Volumes, Timings  
5: Caletti Ave & Shiloh Road

Existing Project Alter. A Conditions  
Timing Plan: P.M. Peak

	→	↘	↙	←	↖	↗
Lane Group	EBT	EBR	WBL	WBT	NBL	NBR
Lane Configurations	↑↑		↙	↑	↖	↗
Traffic Volume (vph)	886	28	79	676	15	149
Future Volume (vph)	886	28	79	676	15	149
Ideal Flow (vphpl)	1900	1900	1900	1900	1900	1900
Storage Length (ft)		0	68		0	0
Storage Lanes		0	1		1	1
Taper Length (ft)			50		25	
Lane Util. Factor	0.95	0.95	1.00	1.00	1.00	1.00
Frt	0.995					0.850
Flt Protected			0.950		0.950	
Satd. Flow (prot)	3522	0	1770	1863	1770	1583
Flt Permitted			0.950		0.950	
Satd. Flow (perm)	3522	0	1770	1863	1770	1583
Link Speed (mph)	40			40	30	
Link Distance (ft)	1081			184	459	
Travel Time (s)	18.4			3.1	10.4	
Peak Hour Factor	0.89	0.89	0.92	0.92	0.89	0.89
Adj. Flow (vph)	996	31	86	735	17	167
Shared Lane Traffic (%)						
Lane Group Flow (vph)	1027	0	86	735	17	167
Enter Blocked Intersection	No	No	No	No	No	No
Lane Alignment	Left	Right	Left	Left	Left	Right
Median Width(ft)	12			12	12	
Link Offset(ft)	0			0	0	
Crosswalk Width(ft)	16			16	16	
Two way Left Turn Lane						
Headway Factor	1.00	1.00	1.00	1.00	1.00	1.00
Turning Speed (mph)		9	15		15	9
Sign Control	Free			Free	Stop	
<b>Intersection Summary</b>						
Area Type:	Other					
Control Type:	Unsignalized					
Intersection Capacity Utilization	45.6%			ICU Level of Service A		
Analysis Period (min)	15					

Lanes, Volumes, Timings  
6: Conde Lane & Shiloh Road

Existing Project Alter. A Conditions  
Timing Plan: P.M. Peak

												
Lane Group	EBL	EBT	EBR	WBL	WBT	WBR	NBL	NBT	NBR	SBL	SBT	SBR
Lane Configurations												
Traffic Volume (vph)	69	505	2	7	481	289	5	3	17	297	0	39
Future Volume (vph)	69	505	2	7	481	289	5	3	17	297	0	39
Ideal Flow (vphpl)	1900	1900	1900	1900	1900	1900	1900	1900	1900	1900	1900	1900
Storage Length (ft)	90		0	127		0	0		0	0		40
Storage Lanes	1		0	1		0	0		0	0		1
Taper Length (ft)	70			40			25			25		
Lane Util. Factor	1.00	0.95	0.95	1.00	0.95	0.95	1.00	1.00	1.00	1.00	1.00	1.00
Ped Bike Factor	1.00				0.99							
Frt		0.999			0.944			0.909				0.850
Flt Protected	0.950			0.950				0.990			0.950	
Satd. Flow (prot)	1770	3536	0	1770	3314	0	0	1676	0	0	1770	1583
Flt Permitted	0.950			0.950				0.990			0.950	
Satd. Flow (perm)	1767	3536	0	1770	3314	0	0	1676	0	0	1770	1583
Right Turn on Red			Yes			Yes			Yes			No
Satd. Flow (RTOR)					130			27				
Link Speed (mph)		40			40			30				35
Link Distance (ft)		815			1081			418				522
Travel Time (s)		13.9			18.4			9.5				10.2
Confl. Peds. (#/hr)	1						1					
Peak Hour Factor	0.88	0.88	0.88	0.80	0.80	0.80	0.63	0.63	0.63	0.88	0.88	0.88
Adj. Flow (vph)	78	574	2	9	601	361	8	5	27	338	0	44
Shared Lane Traffic (%)												
Lane Group Flow (vph)	78	576	0	9	962	0	0	40	0	0	338	44
Enter Blocked Intersection	No	No	No	No	No	No	No	No	No	No	No	No
Lane Alignment	Left	Left	Right	Left	Left	Right	Left	Left	Right	Left	Left	Right
Median Width(ft)		12			12			0				0
Link Offset(ft)		0			0			0				0
Crosswalk Width(ft)		16			16			16				16
Two way Left Turn Lane												
Headway Factor	1.00	1.00	1.00	1.00	1.00	1.00	1.00	1.00	1.00	1.00	1.00	1.00
Turning Speed (mph)	15		9	15		9	15		9	15		9
Number of Detectors	1	2		1	2		1	2		1	1	1
Detector Template	Left	Thru		Left	Thru		Left	Thru		Left	Thru	Right
Leading Detector (ft)	20	100		20	100		20	100		20	30	20
Trailing Detector (ft)	0	0		0	0		0	0		0	0	0
Detector 1 Position(ft)	0	0		0	0		0	0		0	0	0
Detector 1 Size(ft)	20	6		20	6		20	6		20	30	20
Detector 1 Type	Cl+Ex	Cl+Ex		Cl+Ex	Cl+Ex		Cl+Ex	Cl+Ex		Cl+Ex	Cl+Ex	Cl+Ex
Detector 1 Channel												
Detector 1 Extend (s)	0.0	0.0		0.0	0.0		0.0	0.0		0.0	0.0	0.0
Detector 1 Queue (s)	0.0	0.0		0.0	0.0		0.0	0.0		0.0	0.0	0.0
Detector 1 Delay (s)	0.0	0.0		0.0	0.0		0.0	0.0		0.0	0.0	0.0
Detector 2 Position(ft)		94			94			94				
Detector 2 Size(ft)		6			6			6				
Detector 2 Type		Cl+Ex			Cl+Ex			Cl+Ex				
Detector 2 Channel												
Detector 2 Extend (s)		0.0			0.0			0.0				
Turn Type	Prot	NA		Prot	NA		Split	NA		Split	NA	custom

Lanes, Volumes, Timings  
6: Conde Lane & Shiloh Road

Existing Project Alter. A Conditions  
Timing Plan: P.M. Peak

Lane Group	EBL	EBT	EBR	WBL	WBT	WBR	NBL	NBT	NBR	SBL	SBT	SBR
Protected Phases	5	2		1	6		7	7		4	4	
Permitted Phases												6
Detector Phase	5	2		1	6		7	7		4	4	6
Switch Phase												
Minimum Initial (s)	8.0	8.0		8.0	8.0		10.0	10.0		11.0	11.0	8.0
Minimum Split (s)	12.0	46.0		12.0	12.0		37.0	37.0		15.0	15.0	12.0
Total Split (s)	13.0	46.0		12.0	45.0		37.0	37.0		15.0	15.0	45.0
Total Split (%)	11.8%	41.8%		10.9%	40.9%		33.6%	33.6%		13.6%	13.6%	40.9%
Maximum Green (s)	9.0	42.0		8.0	41.0		33.0	33.0		11.0	11.0	41.0
Yellow Time (s)	3.0	3.0		3.0	3.0		3.0	3.0		3.0	3.0	3.0
All-Red Time (s)	1.0	1.0		1.0	1.0		1.0	1.0		1.0	1.0	1.0
Lost Time Adjust (s)	0.0	0.0		0.0	0.0		0.0	0.0		0.0	0.0	0.0
Total Lost Time (s)	4.0	4.0		4.0	4.0		4.0	4.0		4.0	4.0	4.0
Lead/Lag	Lead	Lag		Lead	Lag							Lag
Lead-Lag Optimize?	Yes	Yes		Yes	Yes							Yes
Vehicle Extension (s)	3.0	3.0		3.0	3.0		3.0	3.0		3.0	3.0	3.0
Recall Mode	None	None		None	None		None	None		None	None	None
Walk Time (s)		7.0					7.0	7.0				
Flash Dont Walk (s)		35.0					26.0	26.0				
Pedestrian Calls (#/hr)		0					0	0				
Act Effct Green (s)	9.5	31.7		9.1	24.2		11.3	11.3		12.4	12.4	24.2
Actuated g/C Ratio	0.15	0.51		0.15	0.39		0.18	0.18		0.20	0.20	0.39
v/c Ratio	0.29	0.32		0.03	0.70		0.12	0.12		0.95	0.95	0.07
Control Delay	33.6	10.3		32.3	17.7		17.9	17.9		73.1	73.1	14.3
Queue Delay	0.0	0.0		0.0	0.0		0.0	0.0		0.0	0.0	0.0
Total Delay	33.6	10.3		32.3	17.7		17.9	17.9		73.1	73.1	14.3
LOS	C	B		C	B		B	B		E	E	B
Approach Delay		13.1			17.8		17.9	17.9		66.4	66.4	
Approach LOS		B			B		B	B		E	E	

Intersection Summary

Area Type:	Other
Cycle Length:	110
Actuated Cycle Length:	61.9
Natural Cycle:	120
Control Type:	Actuated-Uncoordinated
Maximum v/c Ratio:	0.95
Intersection Signal Delay:	25.4
Intersection LOS:	C
Intersection Capacity Utilization:	62.4%
ICU Level of Service:	B
Analysis Period (min):	15

Splits and Phases: 6: Conde Lane & Shiloh Road

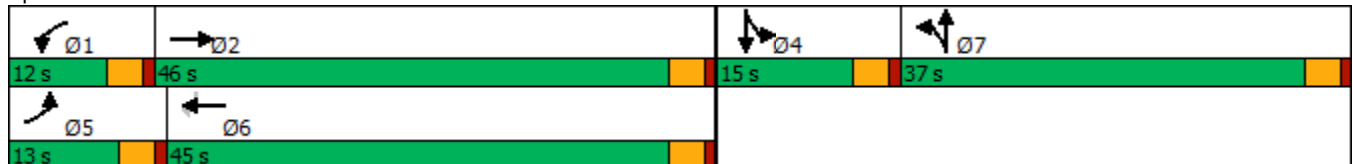



Lanes, Volumes, Timings  
7: Driveway 1/Gridley Drive & Shiloh Road

Existing Project Alter. A Conditions  
Timing Plan: P.M. Peak

Lane Group	EBL	EBT	EBR	WBL	WBT	WBR	NBL	NBT	NBR	SBL	SBT	SBR
Lane Configurations												
Traffic Volume (vph)	17	472	121	0	383	0	84	0	0	0	0	14
Future Volume (vph)	17	472	121	0	383	0	84	0	0	0	0	14
Ideal Flow (vphpl)	1900	1900	1900	1900	1900	1900	1900	1900	1900	1900	1900	1900
Storage Length (ft)	0		150	0		0	0		0	0		0
Storage Lanes	0		1	0		0	1		0	0		0
Taper Length (ft)	25			25			25			25		
Lane Util. Factor	1.00	1.00	1.00	1.00	1.00	1.00	1.00	1.00	1.00	1.00	1.00	1.00
Ped Bike Factor												
Frt			0.850								0.865	
Flt Protected		0.998					0.950					
Satd. Flow (prot)	0	1859	1583	0	1863	0	1770	1863	0	0	1611	0
Flt Permitted		0.998					0.950					
Satd. Flow (perm)	0	1859	1583	0	1863	0	1770	1863	0	0	1611	0
Link Speed (mph)		40			40			30			30	
Link Distance (ft)		608			2146			248			715	
Travel Time (s)		10.4			36.6			5.6			16.3	
Confl. Peds. (#/hr)	1											
Confl. Bikes (#/hr)			1									
Peak Hour Factor	0.94	0.94	0.94	0.69	0.69	0.69	1.00	1.00	1.00	0.58	0.58	0.58
Adj. Flow (vph)	18	502	129	0	555	0	84	0	0	0	0	24
Shared Lane Traffic (%)												
Lane Group Flow (vph)	0	520	129	0	555	0	84	0	0	0	24	0
Enter Blocked Intersection	No	No	No	No	No	No	No	No	No	No	No	No
Lane Alignment	Left	Left	Right	Left	Left	Right	Left	Left	Right	Left	Left	Right
Median Width(ft)		0			0			12			12	
Link Offset(ft)		0			0			0			0	
Crosswalk Width(ft)		16			16			16			16	
Two way Left Turn Lane												
Headway Factor	1.00	1.00	1.00	1.00	1.00	1.00	1.00	1.00	1.00	1.00	1.00	1.00
Turning Speed (mph)	15		9	15		9	15		9	15		9
Sign Control		Free			Free			Stop			Stop	

Intersection Summary	
Area Type:	Other
Control Type:	Unsignalized
Intersection Capacity Utilization	56.6%
Analysis Period (min)	15
	ICU Level of Service B

Lanes, Volumes, Timings  
8: Old Redwood Hwy & Driveway 2

Existing Project Alter. A Conditions

Timing Plan: P.M. Peak



Lane Group	EBL	EBT	EBR	WBL	WBT	WBR	NBL	NBT	NBR	SBL	SBT	SBR
Lane Configurations		↕		↖	↗			↖	↗	↖	↗	
Traffic Volume (vph)	3	0	0	49	0	79	0	505	71	114	427	0
Future Volume (vph)	3	0	0	49	0	79	0	505	71	114	427	0
Ideal Flow (vphp)	1900	1900	1900	1900	1900	1900	1900	1900	1900	1900	1900	1900
Storage Length (ft)	0		0	0		0	0		100	50		0
Storage Lanes	0		0	1		0	0		1	1		0
Taper Length (ft)	25			25			25			25		
Lane Util. Factor	1.00	1.00	1.00	1.00	1.00	1.00	1.00	1.00	1.00	1.00	1.00	1.00
Ped Bike Factor												
Frt					0.850				0.850			
Flt Protected		0.950		0.950						0.950		
Satd. Flow (prot)	0	1770	0	1770	1583	0	0	1863	1583	1770	1863	0
Flt Permitted		0.950		0.950						0.950		
Satd. Flow (perm)	0	1770	0	1770	1583	0	0	1863	1583	1770	1863	0
Link Speed (mph)		30			30			45			45	
Link Distance (ft)		98			385			520			748	
Travel Time (s)		2.2			8.8			7.9			11.3	
Confl. Bikes (#/hr)									3			5
Peak Hour Factor	0.38	0.38	0.38	1.00	1.00	1.00	0.91	0.91	0.91	0.94	0.94	0.94
Adj. Flow (vph)	8	0	0	49	0	79	0	555	78	121	454	0
Shared Lane Traffic (%)												
Lane Group Flow (vph)	0	8	0	49	79	0	0	555	78	121	454	0
Enter Blocked Intersection	No	No	No	No	No	No	No	No	No	No	No	No
Lane Alignment	Left	Left	Right	Left	Left	Right	Left	Left	Right	Left	Left	Right
Median Width(ft)		12			12			12			12	
Link Offset(ft)		0			0			0			0	
Crosswalk Width(ft)		16			16			16			16	
Two way Left Turn Lane												
Headway Factor	1.00	1.00	1.00	1.00	1.00	1.00	1.00	1.00	1.00	1.00	1.00	1.00
Turning Speed (mph)	15		9	15		9	15		9	15		9
Sign Control		Stop			Stop			Free			Free	

Intersection Summary

Area Type:	Other
Control Type:	Unsignalized
Intersection Capacity Utilization	63.9%
ICU Level of Service	B
Analysis Period (min)	15

Lanes, Volumes, Timings  
9: Driveway 3 & Shiloh Road

Existing Project Alter. A Conditions

Timing Plan: P.M. Peak

	→	↘	↙	←	↖	↗
Lane Group	EBT	EBR	WBL	WBT	NBL	NBR
Lane Configurations	↑	↗		↖	↘	↗
Traffic Volume (vph)	81	369	35	111	258	25
Future Volume (vph)	81	369	35	111	258	25
Ideal Flow (vphpl)	1900	1900	1900	1900	1900	1900
Storage Length (ft)		200	0		0	0
Storage Lanes		1	0		1	1
Taper Length (ft)			25		25	
Lane Util. Factor	1.00	1.00	1.00	1.00	1.00	1.00
Frt		0.850				0.850
Flt Protected				0.988	0.950	
Satd. Flow (prot)	1863	1583	0	1840	1770	1583
Flt Permitted				0.988	0.950	
Satd. Flow (perm)	1863	1583	0	1840	1770	1583
Link Speed (mph)	40			40	30	
Link Distance (ft)	2146			134	402	
Travel Time (s)	36.6			2.3	9.1	
Peak Hour Factor	0.92	0.92	0.68	0.68	1.00	1.00
Adj. Flow (vph)	88	401	51	163	258	25
Shared Lane Traffic (%)						
Lane Group Flow (vph)	88	401	0	214	258	25
Enter Blocked Intersection	No	No	No	No	No	No
Lane Alignment	Left	Right	Left	Left	Left	Right
Median Width(ft)	0			0	12	
Link Offset(ft)	0			0	0	
Crosswalk Width(ft)	16			16	16	
Two way Left Turn Lane						
Headway Factor	1.00	1.00	1.00	1.00	1.00	1.00
Turning Speed (mph)		9	15		15	9
Sign Control	Free			Free	Stop	
<b>Intersection Summary</b>						
Area Type:	Other					
Control Type:	Unsignalized					
Intersection Capacity Utilization	37.3%			ICU Level of Service A		
Analysis Period (min)	15					

Lanes, Volumes, Timings

Existing Project Alter. A Conditions

10: US 101 NB Off Ramp/Lakewood Drive & Old Redwood Highway

Timing Plan: P.M. Peak



Lane Group	EBL	EBT	EBR	WBL	WBT	WBR	NBL	NBT	NBR	SBL	SBT	SBR
Lane Configurations	↔↔	↑			↔↔		↔	↔↔		↔↔		↔
Traffic Volume (vph)	261	421	0	0	546	192	500	412	251	249	0	577
Future Volume (vph)	261	421	0	0	546	192	500	412	251	249	0	577
Ideal Flow (vphpl)	1900	1900	1900	1900	1900	1900	1900	1900	1900	1900	1900	1900
Storage Length (ft)	155		0	0		0	270		150	120		0
Storage Lanes	1		0	0		0	1		1	1		1
Taper Length (ft)	50			25			165			75		
Lane Util. Factor	0.97	1.00	1.00	1.00	0.95	0.95	0.91	0.91	0.95	0.97	1.00	1.00
Ped Bike Factor	1.00				0.99			0.99		1.00		
Fr <sub>t</sub>					0.961			0.951				0.850
Fl <sub>t</sub> Protected	0.950						0.950	0.993		0.950		
Satd. Flow (prot)	3433	1863	0	0	3382	0	1610	3181	0	3433	0	1583
Fl <sub>t</sub> Permitted	0.950						0.950	0.993		0.950		
Satd. Flow (perm)	3427	1863	0	0	3382	0	1610	3181	0	3420	0	1583
Right Turn on Red			Yes			Yes			Yes			Yes
Satd. Flow (RTOR)					56			85				283
Link Speed (mph)		35			35			30				30
Link Distance (ft)		226			617			716				478
Travel Time (s)		4.4			12.0			16.3				10.9
Confl. Peds. (#/hr)	3		1	1		3			8	8		
Confl. Bikes (#/hr)			2			9						
Peak Hour Factor	0.87	0.87	0.87	0.91	0.91	0.91	0.92	0.92	0.92	0.96	0.96	0.96
Adj. Flow (vph)	300	484	0	0	600	211	543	448	273	259	0	601
Shared Lane Traffic (%)							22%					
Lane Group Flow (vph)	300	484	0	0	811	0	424	840	0	259	0	601
Enter Blocked Intersection	No	No	No	No	No	No	No	No	No	No	No	No
Lane Alignment	Left	Left	Right	Left	Left	Right	Left	Left	Right	Left	Left	Right
Median Width(ft)		24			24			24				24
Link Offset(ft)		0			0			0				0
Crosswalk Width(ft)		16			16			16				16
Two way Left Turn Lane												
Headway Factor	1.00	1.00	1.00	1.00	1.00	1.00	1.00	1.00	1.00	1.00	1.00	1.00
Turning Speed (mph)	15		9	15		9	15		9	15		9
Number of Detectors	1	2			2		1	2		1		1
Detector Template	Left	Thru			Thru		Left	Thru		Left		Right
Leading Detector (ft)	20	100			100		20	100		20		20
Trailing Detector (ft)	0	0			0		0	0		0		0
Detector 1 Position(ft)	0	0			0		0	0		0		0
Detector 1 Size(ft)	20	6			6		20	6		20		20
Detector 1 Type	Cl+Ex	Cl+Ex			Cl+Ex		Cl+Ex	Cl+Ex		Cl+Ex		Cl+Ex
Detector 1 Channel												
Detector 1 Extend (s)	0.0	0.0			0.0		0.0	0.0		0.0		0.0
Detector 1 Queue (s)	0.0	0.0			0.0		0.0	0.0		0.0		0.0
Detector 1 Delay (s)	0.0	0.0			0.0		0.0	0.0		0.0		0.0
Detector 2 Position(ft)		94			94			94				
Detector 2 Size(ft)		6			6			6				
Detector 2 Type		Cl+Ex			Cl+Ex			Cl+Ex				
Detector 2 Channel												
Detector 2 Extend (s)		0.0			0.0			0.0				

Lanes, Volumes, Timings

Existing Project Alter. A Conditions

10: US 101 NB Off Ramp/Lakewood Drive & Old Redwood Highway

Timing Plan: P.M. Peak

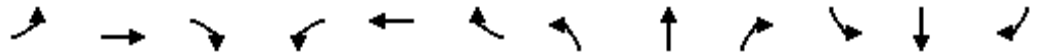

Lane Group	EBL	EBT	EBR	WBL	WBT	WBR	NBL	NBT	NBR	SBL	SBT	SBR
Turn Type	Prot	NA			NA		Split	NA		Prot		pm+ov
Protected Phases	5	2			6		8	8		7		5
Permitted Phases												5 8
Detector Phase	5	2			6		8	8		7		5
Switch Phase												
Minimum Initial (s)	7.0	10.0			10.0		10.0	10.0		7.0		7.0
Minimum Split (s)	11.0	32.1			32.1		33.7	33.7		11.0		11.0
Total Split (s)	13.0	45.3			32.3		33.7	33.7		11.0		13.0
Total Split (%)	14.4%	50.3%			35.9%		37.4%	37.4%		12.2%		14.4%
Maximum Green (s)	9.0	40.2			27.2		29.0	29.0		7.0		9.0
Yellow Time (s)	3.0	4.1			4.1		3.7	3.7		3.0		3.0
All-Red Time (s)	1.0	1.0			1.0		1.0	1.0		1.0		1.0
Lost Time Adjust (s)	0.0	0.0			0.0		0.0	0.0		0.0		0.0
Total Lost Time (s)	4.0	5.1			5.1		4.7	4.7		4.0		4.0
Lead/Lag	Lead				Lag		Lag	Lag		Lead		Lead
Lead-Lag Optimize?	Yes				Yes		Yes	Yes		Yes		Yes
Vehicle Extension (s)	3.0	3.0			3.0		3.0	3.0		3.0		3.0
Recall Mode	None	Max			Max		None	None		None		None
Walk Time (s)		7.0			7.0		7.0	7.0				
Flash Dont Walk (s)		20.0			17.0		22.0	22.0				
Pedestrian Calls (#/hr)		0			0		0	0				
Act Effct Green (s)	9.0	40.2			27.2		27.5	27.5		7.0		41.2
Actuated g/C Ratio	0.10	0.45			0.31		0.31	0.31		0.08		0.47
v/c Ratio	0.86	0.57			0.75		0.85	0.80		0.95		0.68
Control Delay	64.1	21.5			31.2		46.2	31.9		87.1		13.6
Queue Delay	0.0	0.0			0.0		0.0	0.0		0.0		0.0
Total Delay	64.1	21.5			31.2		46.2	31.9		87.1		13.6
LOS	E	C			C		D	C		F		B
Approach Delay		37.8			31.2			36.7				35.7
Approach LOS		D			C			D				D

Intersection Summary

Area Type: Other  
 Cycle Length: 90  
 Actuated Cycle Length: 88.5  
 Natural Cycle: 90  
 Control Type: Actuated-Uncoordinated  
 Maximum v/c Ratio: 0.95  
 Intersection Signal Delay: 35.5  
 Intersection LOS: D  
 Intersection Capacity Utilization 91.7%  
 ICU Level of Service F  
 Analysis Period (min) 15

Splits and Phases: 10: US 101 NB Off Ramp/Lakewood Drive & Old Redwood Highway

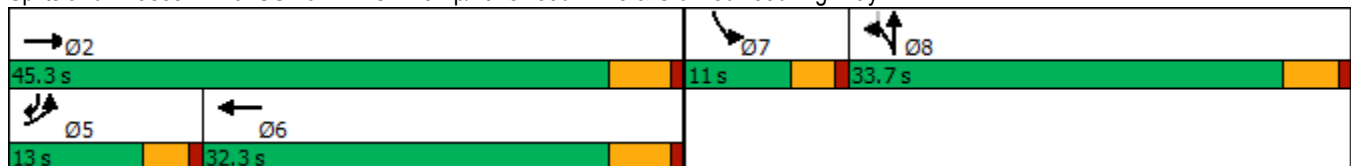

Lanes, Volumes, Timings  
 11: Old Redwood Highway & US 101 NB On Ramp

Existing Project Alter. A Conditions  
 Timing Plan: P.M. Peak



Lane Group	EBL	EBT	WBT	WBR	SBL	SBR
Lane Configurations	↖	↑↑	↗			
Traffic Volume (vph)	106	676	1403	169	0	0
Future Volume (vph)	106	676	1403	169	0	0
Ideal Flow (vphpl)	1900	1900	1900	1900	1900	1900
Storage Length (ft)	245			0	0	0
Storage Lanes	1			0	0	0
Taper Length (ft)	50				25	
Lane Util. Factor	1.00	0.95	0.95	0.95	1.00	1.00
Ped Bike Factor						
Frt			0.984			
Flt Protected	0.950					
Satd. Flow (prot)	1770	3539	3483	0	0	0
Flt Permitted	0.950					
Satd. Flow (perm)	1770	3539	3483	0	0	0
Link Speed (mph)		35	35		30	
Link Distance (ft)		531	226		299	
Travel Time (s)		10.3	4.4		6.8	
Confl. Peds. (#/hr)	17			17		
Confl. Bikes (#/hr)				8		
Peak Hour Factor	0.85	0.85	0.91	0.91	0.25	0.25
Adj. Flow (vph)	125	795	1542	186	0	0
Shared Lane Traffic (%)						
Lane Group Flow (vph)	125	795	1728	0	0	0
Enter Blocked Intersection	No	No	No	No	No	No
Lane Alignment	Left	Left	Left	Right	Left	Right
Median Width(ft)		12	12		0	
Link Offset(ft)		0	0		0	
Crosswalk Width(ft)		16	16		16	
Two way Left Turn Lane						
Headway Factor	1.00	1.00	1.00	1.00	1.00	1.00
Turning Speed (mph)	15			9	15	9
Sign Control		Free	Free		Free	

Intersection Summary	
Area Type:	Other
Control Type:	Unsignalized
Intersection Capacity Utilization	67.0% ICU Level of Service C
Analysis Period (min)	15

Lanes, Volumes, Timings

Existing Project Alter. A Conditions

12: US 101 SB On Ramp/US 101 SB Off Ramp & Old Redwood Highway

Timing Plan: P.M. Peak

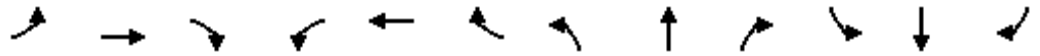

Lane Group	EBL	EBT	EBR	WBL	WBT	WBR	NBL	NBT	NBR	SBL	SBT	SBR
Lane Configurations		↑↑	↗	↖	↑↑					↖	↕	
Traffic Volume (vph)	0	535	381	381	1024	0	0	0	0	238	0	129
Future Volume (vph)	0	535	381	381	1024	0	0	0	0	238	0	129
Ideal Flow (vphpl)	1900	1900	1900	1900	1900	1900	1900	1900	1900	1900	1900	1900
Storage Length (ft)	0		0	250		0	0		0	420		0
Storage Lanes	0		1	0		0	0		0	1		0
Taper Length (ft)	25			165			25			75		
Lane Util. Factor	1.00	0.95	1.00	1.00	0.95	1.00	1.00	1.00	1.00	0.95	0.95	1.00
Ped Bike Factor			0.98	1.00								
Frt			0.850								0.890	
Flt Protected				0.950						0.950	0.987	
Satd. Flow (prot)	0	3539	1583	1770	3539	0	0	0	0	1681	1554	0
Flt Permitted				0.950						0.950	0.987	
Satd. Flow (perm)	0	3539	1558	1768	3539	0	0	0	0	1681	1554	0
Right Turn on Red			Yes			Yes			Yes			Yes
Satd. Flow (RTOR)			405									121
Link Speed (mph)		35			35			30			30	
Link Distance (ft)		423			531			621			831	
Travel Time (s)		8.2			10.3			14.1			18.9	
Confl. Peds. (#/hr)	19		2	2		18						
Confl. Bikes (#/hr)			4			2						
Peak Hour Factor	0.94	0.94	0.94	0.89	0.89	0.89	0.25	0.25	0.25	0.83	0.83	0.83
Adj. Flow (vph)	0	569	405	428	1151	0	0	0	0	287	0	155
Shared Lane Traffic (%)										20%		
Lane Group Flow (vph)	0	569	405	428	1151	0	0	0	0	230	212	0
Enter Blocked Intersection	No	No	No	No	No	No	No	No	No	No	No	No
Lane Alignment	Left	Left	Right	Left	Left	Right	Left	Left	Right	Left	Left	Right
Median Width(ft)		24			24			12			12	
Link Offset(ft)		0			0			0			0	
Crosswalk Width(ft)		16			16			16			16	
Two way Left Turn Lane												
Headway Factor	1.00	1.00	1.00	1.00	1.00	1.00	1.00	1.00	1.00	1.00	1.00	1.00
Turning Speed (mph)	15		9	15		9	15		9	15		9
Number of Detectors		2	1	1	2					1	2	
Detector Template		Thru	Right	Left	Thru					Left	Thru	
Leading Detector (ft)		100	20	20	100					20	100	
Trailing Detector (ft)		0	0	0	0					0	0	
Detector 1 Position(ft)		0	0	0	0					0	0	
Detector 1 Size(ft)		6	20	20	6					20	6	
Detector 1 Type		Cl+Ex	Cl+Ex	Cl+Ex	Cl+Ex					Cl+Ex	Cl+Ex	
Detector 1 Channel												
Detector 1 Extend (s)		0.0	0.0	0.0	0.0					0.0	0.0	
Detector 1 Queue (s)		0.0	0.0	0.0	0.0					0.0	0.0	
Detector 1 Delay (s)		0.0	0.0	0.0	0.0					0.0	0.0	
Detector 2 Position(ft)		94			94							94
Detector 2 Size(ft)		6			6							6
Detector 2 Type		Cl+Ex			Cl+Ex							Cl+Ex
Detector 2 Channel												
Detector 2 Extend (s)		0.0			0.0							0.0

Lanes, Volumes, Timings

Existing Project Alter. A Conditions

12: US 101 SB On Ramp/US 101 SB Off Ramp & Old Redwood Highway

Timing Plan: P.M. Peak



Lane Group	EBL	EBT	EBR	WBL	WBT	WBR	NBL	NBT	NBR	SBL	SBT	SBR
Turn Type		NA	Perm	Prot	NA					Perm	NA	
Protected Phases		6		5	2						8	
Permitted Phases			6							8		
Detector Phase		6	6	5	2					8	8	
Switch Phase												
Minimum Initial (s)		10.0	10.0	7.0	10.0					10.0	10.0	
Minimum Split (s)		32.1	32.1	11.0	38.1					14.7	14.7	
Total Split (s)		33.0	33.0	22.0	55.0					15.0	15.0	
Total Split (%)		47.1%	47.1%	31.4%	78.6%					21.4%	21.4%	
Maximum Green (s)		27.9	27.9	18.0	49.9					10.3	10.3	
Yellow Time (s)		4.1	4.1	3.0	4.1					3.7	3.7	
All-Red Time (s)		1.0	1.0	1.0	1.0					1.0	1.0	
Lost Time Adjust (s)		0.0	0.0	0.0	0.0					0.0	0.0	
Total Lost Time (s)		5.1	5.1	4.0	5.1					4.7	4.7	
Lead/Lag		Lag	Lag	Lead								
Lead-Lag Optimize?		Yes	Yes	Yes								
Vehicle Extension (s)		3.0	3.0	3.0	3.0					3.0	3.0	
Recall Mode		Max	Max	None	Max					None	None	
Walk Time (s)		7.0	7.0		7.0							
Flash Dont Walk (s)		20.0	20.0		25.0							
Pedestrian Calls (#/hr)		0	0		0							
Act Effct Green (s)		27.9	27.9	18.0	49.9					10.3	10.3	
Actuated g/C Ratio		0.40	0.40	0.26	0.71					0.15	0.15	
v/c Ratio		0.40	0.47	0.94	0.46					0.93	0.64	
Control Delay		16.2	3.7	58.2	5.0					75.4	23.0	
Queue Delay		0.0	0.0	0.0	0.0					0.0	0.0	
Total Delay		16.2	3.7	58.2	5.0					75.4	23.0	
LOS		B	A	E	A					E	C	
Approach Delay		11.0			19.4						50.3	
Approach LOS		B			B						D	

Intersection Summary

Area Type: Other  
 Cycle Length: 70  
 Actuated Cycle Length: 70  
 Natural Cycle: 75  
 Control Type: Actuated-Uncoordinated  
 Maximum v/c Ratio: 0.94  
 Intersection Signal Delay: 21.2  
 Intersection LOS: C  
 Intersection Capacity Utilization 67.0%  
 ICU Level of Service C  
 Analysis Period (min) 15

Splits and Phases: 12: US 101 SB On Ramp/US 101 SB Off Ramp & Old Redwood Highway

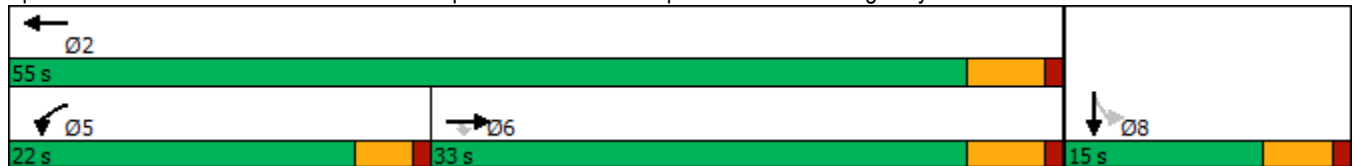



Lanes, Volumes, Timings  
1: Old Redwood Hwy & Shiloh Road

Existing Project Alter. A Conditions  
Timing Plan: Saturday Midday Peak



Lane Group	EBL	EBT	EBR	WBL	WBT	WBR	NBL	NBT	NBR	SBL	SBT	SBR
Lane Configurations												
Traffic Volume (vph)	123	472	238	21	488	6	246	243	24	73	197	180
Future Volume (vph)	123	472	238	21	488	6	246	243	24	73	197	180
Ideal Flow (vphpl)	1900	1900	1900	1900	1900	1900	1900	1900	1900	1900	1900	1900
Storage Length (ft)	375		140	0		50	200		98	130		93
Storage Lanes	1		1	0		1	1		1	1		1
Taper Length (ft)	50			25			60			93		
Lane Util. Factor	1.00	1.00	1.00	1.00	1.00	1.00	1.00	1.00	1.00	1.00	1.00	1.00
Ped Bike Factor	1.00		0.98						0.98			0.97
Frt			0.850			0.850			0.850			0.850
Flt Protected	0.950				0.998		0.950			0.950		
Satd. Flow (prot)	1770	1863	1583	0	1859	1583	1770	1863	1583	1770	1863	1583
Flt Permitted	0.950				0.998		0.950			0.950		
Satd. Flow (perm)	1764	1863	1549	0	1859	1583	1770	1863	1550	1770	1863	1540
Right Turn on Red			Yes			Yes			Yes			Yes
Satd. Flow (RTOR)			115			105			77			156
Link Speed (mph)		40			40			45				40
Link Distance (ft)		1789			608			748				775
Travel Time (s)		30.5			10.4			11.3				13.2
Confl. Peds. (#/hr)	4											
Confl. Bikes (#/hr)			1						1			5
Peak Hour Factor	0.89	0.89	0.89	0.86	0.86	0.86	0.93	0.93	0.93	0.91	0.91	0.91
Adj. Flow (vph)	138	530	267	24	567	7	265	261	26	80	216	198
Shared Lane Traffic (%)												
Lane Group Flow (vph)	138	530	267	0	591	7	265	261	26	80	216	198
Enter Blocked Intersection	No	No	No	No	No	No	No	No	No	No	No	No
Lane Alignment	Left	Left	Right	Left	Left	Right	Left	Left	Right	Left	Left	Right
Median Width(ft)		12			12			12				12
Link Offset(ft)		0			0			0				0
Crosswalk Width(ft)		16			16			16				16
Two way Left Turn Lane												
Headway Factor	1.00	1.00	1.00	1.00	1.00	1.00	1.00	1.00	1.00	1.00	1.00	1.00
Turning Speed (mph)	15		9	15		9	15		9	15		9
Number of Detectors	1	2	1	1	2	1	1	2	1	1	2	1
Detector Template	Left	Thru	Right	Left	Thru	Right	Left	Thru	Right	Left	Thru	Right
Leading Detector (ft)	20	100	20	20	100	20	20	100	20	20	100	20
Trailing Detector (ft)	0	0	0	0	0	0	0	0	0	0	0	0
Detector 1 Position(ft)	0	0	0	0	0	0	0	0	0	0	0	0
Detector 1 Size(ft)	20	6	20	20	6	20	20	6	20	20	6	20
Detector 1 Type	Cl+Ex	Cl+Ex	Cl+Ex	Cl+Ex	Cl+Ex	Cl+Ex	Cl+Ex	Cl+Ex	Cl+Ex	Cl+Ex	Cl+Ex	Cl+Ex
Detector 1 Channel												
Detector 1 Extend (s)	0.0	0.0	0.0	0.0	0.0	0.0	0.0	0.0	0.0	0.0	0.0	0.0
Detector 1 Queue (s)	0.0	0.0	0.0	0.0	0.0	0.0	0.0	0.0	0.0	0.0	0.0	0.0
Detector 1 Delay (s)	0.0	0.0	0.0	0.0	0.0	0.0	0.0	0.0	0.0	0.0	0.0	0.0
Detector 2 Position(ft)		94			94			94				94
Detector 2 Size(ft)		6			6			6				6
Detector 2 Type		Cl+Ex			Cl+Ex			Cl+Ex				Cl+Ex
Detector 2 Channel												
Detector 2 Extend (s)		0.0			0.0			0.0				0.0

Lanes, Volumes, Timings  
1: Old Redwood Hwy & Shiloh Road

Existing Project Alter. A Conditions  
Timing Plan: Saturday Midday Peak



Lane Group	EBL	EBT	EBR	WBL	WBT	WBR	NBL	NBT	NBR	SBL	SBT	SBR
Turn Type	Split	NA	Perm	Split	NA	Perm	Prot	NA	Perm	Prot	NA	Perm
Protected Phases	2	2		6	6		3	8		7	4	
Permitted Phases			2			6			8			4
Detector Phase	2	2	2	6	6	6	3	8	8	7	4	4
Switch Phase												
Minimum Initial (s)	5.0	5.0	5.0	5.0	5.0	5.0	5.0	5.0	5.0	5.0	5.0	5.0
Minimum Split (s)	34.5	34.5	34.5	42.5	42.5	42.5	8.5	46.5	46.5	8.5	39.5	39.5
Total Split (s)	35.0	35.0	35.0	42.5	42.5	42.5	18.0	48.0	48.0	9.5	39.5	39.5
Total Split (%)	25.9%	25.9%	25.9%	31.5%	31.5%	31.5%	13.3%	35.6%	35.6%	7.0%	29.3%	29.3%
Maximum Green (s)	30.5	30.5	30.5	38.0	38.0	38.0	14.5	43.5	43.5	6.0	35.0	35.0
Yellow Time (s)	3.5	3.5	3.5	3.5	3.5	3.5	3.0	3.5	3.5	3.0	3.5	3.5
All-Red Time (s)	1.0	1.0	1.0	1.0	1.0	1.0	0.5	1.0	1.0	0.5	1.0	1.0
Lost Time Adjust (s)	0.0	0.0	0.0		0.0	0.0	0.0	0.0	0.0	0.0	0.0	0.0
Total Lost Time (s)	4.5	4.5	4.5		4.5	4.5	3.5	4.5	4.5	3.5	4.5	4.5
Lead/Lag	Lead	Lead	Lead	Lag	Lag	Lag	Lead	Lag	Lag	Lead	Lag	Lag
Lead-Lag Optimize?	Yes	Yes	Yes	Yes	Yes	Yes	Yes	Yes	Yes	Yes	Yes	Yes
Vehicle Extension (s)	3.0	3.0	3.0	3.0	3.0	3.0	3.0	3.0	3.0	3.0	3.0	3.0
Recall Mode	None	None	None	None	None	None	None	None	None	None	None	None
Walk Time (s)	7.0	7.0	7.0	7.0	7.0	7.0		7.0	7.0		7.0	7.0
Flash Dont Walk (s)	23.0	23.0	23.0	31.0	31.0	31.0		35.0	35.0		28.0	28.0
Pedestrian Calls (#/hr)	0	0	0	0	0	0		0	0		0	0
Act Effct Green (s)	30.6	30.6	30.6		38.1	38.1	14.5	27.6	27.6	6.0	19.1	19.1
Actuated g/C Ratio	0.26	0.26	0.26		0.32	0.32	0.12	0.23	0.23	0.05	0.16	0.16
v/c Ratio	0.30	1.11	0.55		1.00	0.01	1.23	0.61	0.06	0.90	0.72	0.53
Control Delay	39.2	116.9	27.0		77.6	0.0	182.1	47.1	0.3	128.7	61.8	16.8
Queue Delay	0.0	0.0	0.0		0.0	0.0	0.0	0.0	0.0	0.0	0.0	0.0
Total Delay	39.2	116.9	27.0		77.6	0.0	182.1	47.1	0.3	128.7	61.8	16.8
LOS	D	F	C		E	A	F	D	A	F	E	B
Approach Delay		79.8			76.7			109.7			54.6	
Approach LOS		E			E			F			D	

Intersection Summary

Area Type:	Other
Cycle Length:	135
Actuated Cycle Length:	119.3
Natural Cycle:	145
Control Type:	Actuated-Uncoordinated
Maximum v/c Ratio:	1.23
Intersection Signal Delay:	80.7
Intersection LOS:	F
Intersection Capacity Utilization:	90.3%
ICU Level of Service:	E
Analysis Period (min):	15

Splits and Phases: 1: Old Redwood Hwy & Shiloh Road



Lanes, Volumes, Timings  
2: Shiloh Road & Hembree Ln

Existing Project Alter. A Conditions  
Timing Plan: Saturday Midday Peak



Lane Group	EBL	EBT	WBT	WBR	SBL	SBR
Lane Configurations	↶↶	↶	↶↶		↶	↷
Traffic Volume (vph)	622	745	715	159	160	580
Future Volume (vph)	622	745	715	159	160	580
Ideal Flow (vphp)	1900	1900	1900	1900	1900	1900
Storage Length (ft)	0			130	0	0
Storage Lanes	2			1	1	1
Taper Length (ft)	25				25	
Lane Util. Factor	0.97	1.00	0.95	0.95	1.00	1.00
Ped Bike Factor	1.00		1.00			
Frt			0.973			0.850
Flt Protected	0.950				0.950	
Satd. Flow (prot)	3433	1863	3436	0	1770	1583
Flt Permitted	0.950				0.950	
Satd. Flow (perm)	3432	1863	3436	0	1770	1583
Right Turn on Red				Yes		Yes
Satd. Flow (RTOR)			38			118
Link Speed (mph)		40	40		35	
Link Distance (ft)		302	1789		381	
Travel Time (s)		5.1	30.5		7.4	
Confl. Peds. (#/hr)	1			1		
Peak Hour Factor	0.94	0.94	0.96	0.96	0.91	0.91
Adj. Flow (vph)	662	793	745	166	176	637
Shared Lane Traffic (%)						
Lane Group Flow (vph)	662	793	911	0	176	637
Enter Blocked Intersection	No	No	No	No	No	No
Lane Alignment	Left	Left	Left	Right	Left	Right
Median Width(ft)		24	24		12	
Link Offset(ft)		0	0		0	
Crosswalk Width(ft)		16	16		16	
Two way Left Turn Lane						
Headway Factor	1.00	1.00	1.00	1.00	1.00	1.00
Turning Speed (mph)	15			9	15	9
Number of Detectors	1	2	2		1	1
Detector Template	Left	Thru	Thru		Left	Right
Leading Detector (ft)	20	100	100		20	20
Trailing Detector (ft)	0	0	0		0	0
Detector 1 Position(ft)	0	0	0		0	0
Detector 1 Size(ft)	20	6	6		20	20
Detector 1 Type	Cl+Ex	Cl+Ex	Cl+Ex		Cl+Ex	Cl+Ex
Detector 1 Channel						
Detector 1 Extend (s)	0.0	0.0	0.0		0.0	0.0
Detector 1 Queue (s)	0.0	0.0	0.0		0.0	0.0
Detector 1 Delay (s)	0.0	0.0	0.0		0.0	0.0
Detector 2 Position(ft)		94	94			
Detector 2 Size(ft)		6	6			
Detector 2 Type		Cl+Ex	Cl+Ex			
Detector 2 Channel						
Detector 2 Extend (s)		0.0	0.0			
Turn Type	Prot	NA	NA		Perm	pm+ov

Lanes, Volumes, Timings  
2: Shiloh Road & Hembree Ln

Existing Project Alter. A Conditions  
Timing Plan: Saturday Midday Peak



Lane Group	EBL	EBT	WBT	WBR	SBL	SBR
Protected Phases	5	2	6			5
Permitted Phases					4	4 5
Detector Phase	5	2	6		4	5
Switch Phase						
Minimum Initial (s)	3.0	5.0	5.0		5.0	3.0
Minimum Split (s)	7.0	9.0	43.0		9.0	7.0
Total Split (s)	29.0	73.0	44.0		17.0	29.0
Total Split (%)	32.2%	81.1%	48.9%		18.9%	32.2%
Maximum Green (s)	25.0	69.0	40.0		13.0	25.0
Yellow Time (s)	3.0	3.0	3.0		3.0	3.0
All-Red Time (s)	1.0	1.0	1.0		1.0	1.0
Lost Time Adjust (s)	0.0	0.0	0.0		0.0	0.0
Total Lost Time (s)	4.0	4.0	4.0		4.0	4.0
Lead/Lag	Lead		Lag			Lead
Lead-Lag Optimize?	Yes		Yes			Yes
Vehicle Extension (s)	3.0	3.0	3.0		3.0	3.0
Recall Mode	None	None	None		None	None
Walk Time (s)			7.0			
Flash Dont Walk (s)			32.0			
Pedestrian Calls (#/hr)			0			
Act Effct Green (s)	20.2	49.8	25.5		11.5	35.9
Actuated g/C Ratio	0.29	0.71	0.37		0.16	0.52
v/c Ratio	0.67	0.60	0.71		0.60	0.73
Control Delay	26.6	7.0	22.0		40.1	17.7
Queue Delay	0.0	0.1	0.0		0.0	0.0
Total Delay	26.6	7.1	22.0		40.1	17.7
LOS	C	A	C		D	B
Approach Delay		16.0	22.0		22.6	
Approach LOS		B	C		C	

Intersection Summary







Area Type:	Other
Cycle Length:	90
Actuated Cycle Length:	69.7
Natural Cycle:	80
Control Type:	Actuated-Uncoordinated
Maximum v/c Ratio:	0.73
Intersection Signal Delay:	19.4
Intersection LOS:	B
Intersection Capacity Utilization:	67.7%
ICU Level of Service:	C
Analysis Period (min):	15

Splits and Phases: 2: Shiloh Road & Hembree Ln



Lanes, Volumes, Timings  
3: US 101 NB Off-Ramp & Shiloh Road

Existing Project Alter. A Conditions  
Timing Plan: Saturday Midday Peak

						
Lane Group	EBT	EBR	WBL	WBT	NBL	NBR
Lane Configurations	↑↑			↑	↘	↗
Traffic Volume (vph)	551	0	0	952	352	814
Future Volume (vph)	551	0	0	952	352	814
Ideal Flow (vphpl)	1900	1900	1900	1900	1900	1900
Storage Length (ft)		0	0		0	265
Storage Lanes		0	0		1	2
Taper Length (ft)			25		25	
Lane Util. Factor	0.95	1.00	1.00	1.00	1.00	0.88
Ped Bike Factor						
Frt						0.850
Flt Protected					0.950	
Satd. Flow (prot)	3539	0	0	1863	1770	2787
Flt Permitted					0.950	
Satd. Flow (perm)	3539	0	0	1863	1770	2787
Right Turn on Red		Yes				Yes
Satd. Flow (RTOR)						341
Link Speed (mph)	40			40	30	
Link Distance (ft)	186			371	769	
Travel Time (s)	3.2			6.3	17.5	
Confl. Bikes (#/hr)		1				
Peak Hour Factor	0.91	0.91	0.89	0.89	0.95	0.95
Adj. Flow (vph)	605	0	0	1070	371	857
Shared Lane Traffic (%)						
Lane Group Flow (vph)	605	0	0	1070	371	857
Enter Blocked Intersection	No	No	No	No	No	No
Lane Alignment	Left	Right	Left	Left	Left	Right
Median Width(ft)	0			0	12	
Link Offset(ft)	0			0	0	
Crosswalk Width(ft)	16			16	16	
Two way Left Turn Lane						
Headway Factor	1.00	1.00	1.00	1.00	1.00	1.00
Turning Speed (mph)		9	15		15	9
Number of Detectors	2			2	1	1
Detector Template	Thru			Thru	Left	Right
Leading Detector (ft)	100			100	20	20
Trailing Detector (ft)	0			0	0	0
Detector 1 Position(ft)	0			0	0	0
Detector 1 Size(ft)	6			6	20	20
Detector 1 Type	Cl+Ex			Cl+Ex	Cl+Ex	Cl+Ex
Detector 1 Channel						
Detector 1 Extend (s)	0.0			0.0	0.0	0.0
Detector 1 Queue (s)	0.0			0.0	0.0	0.0
Detector 1 Delay (s)	0.0			0.0	0.0	0.0
Detector 2 Position(ft)	94			94		
Detector 2 Size(ft)	6			6		
Detector 2 Type	Cl+Ex			Cl+Ex		
Detector 2 Channel						
Detector 2 Extend (s)	0.0			0.0		
Turn Type	NA			NA	Prot	Perm

Lanes, Volumes, Timings  
 3: US 101 NB Off-Ramp & Shiloh Road

Existing Project Alter. A Conditions  
 Timing Plan: Saturday Midday Peak



Lane Group	EBT	EBR	WBL	WBT	NBL	NBR
Protected Phases	2			6	8	
Permitted Phases						8
Detector Phase	2			6	8	8
Switch Phase						
Minimum Initial (s)	5.0			5.0	5.0	5.0
Minimum Split (s)	9.0			9.0	9.0	9.0
Total Split (s)	37.0			37.0	35.0	35.0
Total Split (%)	51.4%			51.4%	48.6%	48.6%
Maximum Green (s)	33.0			33.0	31.0	31.0
Yellow Time (s)	3.0			3.0	3.0	3.0
All-Red Time (s)	1.0			1.0	1.0	1.0
Lost Time Adjust (s)	0.0			0.0	0.0	0.0
Total Lost Time (s)	4.0			4.0	4.0	4.0
Lead/Lag						
Lead-Lag Optimize?						
Vehicle Extension (s)	3.0			3.0	3.0	3.0
Recall Mode	None			None	None	None
Act Effct Green (s)	33.4			33.4	20.3	20.3
Actuated g/C Ratio	0.54			0.54	0.33	0.33
v/c Ratio	0.32			1.06	0.64	0.75
Control Delay	9.7			66.1	22.5	14.9
Queue Delay	0.0			0.0	0.0	0.0
Total Delay	9.7			66.1	22.5	14.9
LOS	A			E	C	B
Approach Delay	9.7			66.1	17.2	
Approach LOS	A			E	B	

Intersection Summary

Area Type: Other  
 Cycle Length: 72  
 Actuated Cycle Length: 61.7  
 Natural Cycle: 65  
 Control Type: Actuated-Uncoordinated  
 Maximum v/c Ratio: 1.06  
 Intersection Signal Delay: 33.6  
 Intersection LOS: C  
 Intersection Capacity Utilization 132.5%  
 ICU Level of Service H  
 Analysis Period (min) 15

Splits and Phases: 3: US 101 NB Off-Ramp & Shiloh Road

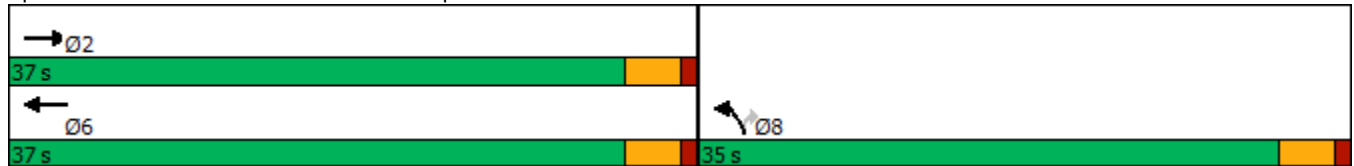

Lanes, Volumes, Timings  
4: Shiloh Road & US 101 SB Off-Ramp

Existing Project Alter. A Conditions  
Timing Plan: Saturday Midday Peak



Lane Group	EBL	EBT	WBT	WBR	SBL	SBR
Lane Configurations		↑	↑		↓	↓
Traffic Volume (vph)	0	298	549	0	332	151
Future Volume (vph)	0	298	549	0	332	151
Ideal Flow (vphp)	1900	1900	1900	1900	1900	1900
Storage Length (ft)	0			0	0	275
Storage Lanes	0			0	1	1
Taper Length (ft)	25				25	
Lane Util. Factor	1.00	1.00	1.00	1.00	1.00	1.00
Ped Bike Factor						
Frt						0.850
Flt Protected					0.950	
Satd. Flow (prot)	0	1863	1863	0	1770	1583
Flt Permitted					0.950	
Satd. Flow (perm)	0	1863	1863	0	1770	1583
Right Turn on Red				Yes		Yes
Satd. Flow (RTOR)						222
Link Speed (mph)		40	40		30	
Link Distance (ft)		225	306		486	
Travel Time (s)		3.8	5.2		11.0	
Confl. Bikes (#/hr)				2		
Peak Hour Factor	0.96	0.96	0.96	0.96	0.68	0.68
Adj. Flow (vph)	0	310	572	0	488	222
Shared Lane Traffic (%)						
Lane Group Flow (vph)	0	310	572	0	488	222
Enter Blocked Intersection	No	No	No	No	No	No
Lane Alignment	Left	Left	Left	Right	Left	Right
Median Width(ft)		4	0		12	
Link Offset(ft)		0	0		0	
Crosswalk Width(ft)		16	16		16	
Two way Left Turn Lane						
Headway Factor	1.00	1.00	1.00	1.00	1.00	1.00
Turning Speed (mph)	15			9	15	9
Number of Detectors		2	2		1	1
Detector Template		Thru	Thru		Left	Right
Leading Detector (ft)		100	100		20	20
Trailing Detector (ft)		0	0		0	0
Detector 1 Position(ft)		0	0		0	0
Detector 1 Size(ft)		6	6		20	20
Detector 1 Type		Cl+Ex	Cl+Ex		Cl+Ex	Cl+Ex
Detector 1 Channel						
Detector 1 Extend (s)		0.0	0.0		0.0	0.0
Detector 1 Queue (s)		0.0	0.0		0.0	0.0
Detector 1 Delay (s)		0.0	0.0		0.0	0.0
Detector 2 Position(ft)		94	94			
Detector 2 Size(ft)		6	6			
Detector 2 Type		Cl+Ex	Cl+Ex			
Detector 2 Channel						
Detector 2 Extend (s)		0.0	0.0			
Turn Type		NA	NA		Perm	Perm

Lanes, Volumes, Timings  
4: Shiloh Road & US 101 SB Off-Ramp

Existing Project Alter. A Conditions  
Timing Plan: Saturday Midday Peak



Lane Group	EBL	EBT	WBT	WBR	SBL	SBR
Protected Phases		2	6			
Permitted Phases					4	4
Detector Phase		2	6		4	4
Switch Phase						
Minimum Initial (s)		5.0	5.0		5.0	5.0
Minimum Split (s)		9.0	38.0		9.0	9.0
Total Split (s)		69.0	69.0		21.0	21.0
Total Split (%)		76.7%	76.7%		23.3%	23.3%
Maximum Green (s)		65.0	65.0		17.0	17.0
Yellow Time (s)		3.0	3.0		3.0	3.0
All-Red Time (s)		1.0	1.0		1.0	1.0
Lost Time Adjust (s)		0.0	0.0		0.0	0.0
Total Lost Time (s)		4.0	4.0		4.0	4.0
Lead/Lag						
Lead-Lag Optimize?						
Vehicle Extension (s)		3.0	3.0		3.0	3.0
Recall Mode		None	None		None	None
Walk Time (s)			7.0			
Flash Dont Walk (s)			27.0			
Pedestrian Calls (#/hr)			0			
Act Effct Green (s)		18.6	18.6		17.2	17.2
Actuated g/C Ratio		0.42	0.42		0.39	0.39
v/c Ratio		0.39	0.73		0.70	0.29
Control Delay		10.0	16.3		21.2	3.5
Queue Delay		0.0	0.0		0.0	0.0
Total Delay		10.0	16.3		21.2	3.5
LOS		A	B		C	A
Approach Delay		10.0	16.3		15.7	
Approach LOS		A	B		B	

Intersection Summary

Area Type:	Other
Cycle Length:	90
Actuated Cycle Length:	43.9
Natural Cycle:	60
Control Type:	Actuated-Uncoordinated
Maximum v/c Ratio:	0.73
Intersection Signal Delay:	14.8
Intersection LOS:	B
Intersection Capacity Utilization:	118.7%
ICU Level of Service:	H
Analysis Period (min):	15

Splits and Phases: 4: Shiloh Road & US 101 SB Off-Ramp





Lanes, Volumes, Timings  
5: Caletti Ave & Shiloh Road

Existing Project Alter. A Conditions  
Timing Plan: Saturday Midday Peak

	→	↘	↙	←	↖	↗
Lane Group	EBT	EBR	WBL	WBT	NBL	NBR
Lane Configurations	↑↑		↘	↑	↘	↗
Traffic Volume (vph)	570	20	81	628	16	78
Future Volume (vph)	570	20	81	628	16	78
Ideal Flow (vphp)	1900	1900	1900	1900	1900	1900
Storage Length (ft)		0	68		0	0
Storage Lanes		0	1		1	1
Taper Length (ft)			50		25	
Lane Util. Factor	0.95	0.95	1.00	1.00	1.00	1.00
Ped Bike Factor						
Frt	0.995					0.850
Flt Protected			0.950		0.950	
Satd. Flow (prot)	3522	0	1770	1863	1770	1583
Flt Permitted			0.950		0.950	
Satd. Flow (perm)	3522	0	1770	1863	1770	1583
Link Speed (mph)	40			40	30	
Link Distance (ft)	1081			184	459	
Travel Time (s)	18.4			3.1	10.4	
Confl. Peds. (#/hr)					1	
Confl. Bikes (#/hr)		1				
Peak Hour Factor	0.92	0.92	0.87	0.87	0.78	0.78
Adj. Flow (vph)	620	22	93	722	21	100
Shared Lane Traffic (%)						
Lane Group Flow (vph)	642	0	93	722	21	100
Enter Blocked Intersection	No	No	No	No	No	No
Lane Alignment	Left	Right	Left	Left	Left	Right
Median Width(ft)	12			12	12	
Link Offset(ft)	0			0	0	
Crosswalk Width(ft)	16			16	16	
Two way Left Turn Lane						
Headway Factor	1.00	1.00	1.00	1.00	1.00	1.00
Turning Speed (mph)		9	15		15	9
Sign Control	Free			Free	Stop	

Intersection Summary

Area Type:	Other
Control Type:	Unsignalized
Intersection Capacity Utilization	43.1% ICU Level of Service A
Analysis Period (min)	15

Lanes, Volumes, Timings  
6: Conde Lane & Shiloh Road

Existing Project Alter. A Conditions  
Timing Plan: Saturday Midday Peak



Lane Group	EBL	EBT	EBR	WBL	WBT	WBR	NBL	NBT	NBR	SBL	SBT	SBR
Lane Configurations												
Traffic Volume (vph)	29	386	1	9	427	204	1	0	6	197	0	28
Future Volume (vph)	29	386	1	9	427	204	1	0	6	197	0	28
Ideal Flow (vphpl)	1900	1900	1900	1900	1900	1900	1900	1900	1900	1900	1900	1900
Storage Length (ft)	90		0	127		0	0		0	0		40
Storage Lanes	1		0	1		0	0		0	0		1
Taper Length (ft)	70			40			25			25		
Lane Util. Factor	1.00	0.95	0.95	1.00	0.95	0.95	1.00	1.00	1.00	1.00	1.00	1.00
Ped Bike Factor					0.99							
Frt					0.952			0.887				0.850
Flt Protected	0.950			0.950				0.992			0.950	
Satd. Flow (prot)	1770	3539	0	1770	3345	0	0	1639	0	0	1770	1583
Flt Permitted	0.950			0.950				0.992			0.950	
Satd. Flow (perm)	1770	3539	0	1770	3345	0	0	1639	0	0	1770	1583
Right Turn on Red			Yes			Yes			Yes			No
Satd. Flow (RTOR)					83			89				
Link Speed (mph)		40			40			30				35
Link Distance (ft)		815			1081			418				522
Travel Time (s)		13.9			18.4			9.5				10.2
Confl. Bikes (#/hr)						2						
Peak Hour Factor	0.96	0.96	0.96	0.91	0.91	0.91	0.58	0.58	0.58	0.78	0.78	0.78
Adj. Flow (vph)	30	402	1	10	469	224	2	0	10	253	0	36
Shared Lane Traffic (%)												
Lane Group Flow (vph)	30	403	0	10	693	0	0	12	0	0	253	36
Enter Blocked Intersection	No	No	No	No	No	No	No	No	No	No	No	No
Lane Alignment	Left	Left	Right	Left	Left	Right	Left	Left	Right	Left	Left	Right
Median Width(ft)		12			12			0				0
Link Offset(ft)		0			0			0				0
Crosswalk Width(ft)		16			16			16				16
Two way Left Turn Lane												
Headway Factor	1.00	1.00	1.00	1.00	1.00	1.00	1.00	1.00	1.00	1.00	1.00	1.00
Turning Speed (mph)	15		9	15		9	15		9	15		9
Number of Detectors	1	2		1	2		1	2		1	1	1
Detector Template	Left	Thru		Left	Thru		Left	Thru		Left	Thru	Right
Leading Detector (ft)	20	100		20	100		20	100		20	30	20
Trailing Detector (ft)	0	0		0	0		0	0		0	0	0
Detector 1 Position(ft)	0	0		0	0		0	0		0	0	0
Detector 1 Size(ft)	20	6		20	6		20	6		20	30	20
Detector 1 Type	Cl+Ex	Cl+Ex		Cl+Ex	Cl+Ex		Cl+Ex	Cl+Ex		Cl+Ex	Cl+Ex	Cl+Ex
Detector 1 Channel												
Detector 1 Extend (s)	0.0	0.0		0.0	0.0		0.0	0.0		0.0	0.0	0.0
Detector 1 Queue (s)	0.0	0.0		0.0	0.0		0.0	0.0		0.0	0.0	0.0
Detector 1 Delay (s)	0.0	0.0		0.0	0.0		0.0	0.0		0.0	0.0	0.0
Detector 2 Position(ft)		94			94			94				
Detector 2 Size(ft)		6			6			6				
Detector 2 Type		Cl+Ex			Cl+Ex			Cl+Ex				
Detector 2 Channel												
Detector 2 Extend (s)		0.0			0.0			0.0				
Turn Type	Prot	NA		Prot	NA		Split	NA		Split	NA	custom

Lanes, Volumes, Timings  
6: Conde Lane & Shiloh Road

Existing Project Alter. A Conditions  
Timing Plan: Saturday Midday Peak

Lane Group	EBL	EBT	EBR	WBL	WBT	WBR	NBL	NBT	NBR	SBL	SBT	SBR
Protected Phases	5	2		1	6		7	7		4	4	
Permitted Phases												6
Detector Phase	5	2		1	6		7	7		4	4	6
Switch Phase												
Minimum Initial (s)	8.0	8.0		8.0	8.0		10.0	10.0		11.0	11.0	8.0
Minimum Split (s)	12.0	46.0		12.0	12.0		37.0	37.0		15.0	15.0	12.0
Total Split (s)	13.0	46.0		12.0	45.0		37.0	37.0		15.0	15.0	45.0
Total Split (%)	11.8%	41.8%		10.9%	40.9%		33.6%	33.6%		13.6%	13.6%	40.9%
Maximum Green (s)	9.0	42.0		8.0	41.0		33.0	33.0		11.0	11.0	41.0
Yellow Time (s)	3.0	3.0		3.0	3.0		3.0	3.0		3.0	3.0	3.0
All-Red Time (s)	1.0	1.0		1.0	1.0		1.0	1.0		1.0	1.0	1.0
Lost Time Adjust (s)	0.0	0.0		0.0	0.0		0.0	0.0		0.0	0.0	0.0
Total Lost Time (s)	4.0	4.0		4.0	4.0		4.0	4.0		4.0	4.0	4.0
Lead/Lag	Lead	Lag		Lead	Lag							Lag
Lead-Lag Optimize?	Yes	Yes		Yes	Yes							Yes
Vehicle Extension (s)	3.0	3.0		3.0	3.0		3.0	3.0		3.0	3.0	3.0
Recall Mode	None	None		None	None		None	None		None	None	None
Walk Time (s)		7.0					7.0	7.0				
Flash Dont Walk (s)		35.0					26.0	26.0				
Pedestrian Calls (#/hr)		0					0	0				
Act Effct Green (s)	9.0	15.2		8.9	15.2		11.1	11.1		12.3	12.3	15.2
Actuated g/C Ratio	0.23	0.39		0.23	0.39		0.28	0.28		0.31	0.31	0.39
v/c Ratio	0.07	0.29		0.02	0.52		0.02	0.02		0.46	0.46	0.06
Control Delay	19.3	10.1		19.7	10.7		0.1	0.1		21.3	21.3	10.3
Queue Delay	0.0	0.0		0.0	0.0		0.0	0.0		0.0	0.0	0.0
Total Delay	19.3	10.1		19.7	10.7		0.1	0.1		21.3	21.3	10.3
LOS	B	B		B	B		A	A		C	C	B
Approach Delay		10.7			10.8		0.1	0.1		19.9	19.9	
Approach LOS		B			B		A	A		B	B	

Intersection Summary

Area Type:	Other
Cycle Length:	110
Actuated Cycle Length:	39.3
Natural Cycle:	110
Control Type:	Actuated-Uncoordinated
Maximum v/c Ratio:	0.52
Intersection Signal Delay:	12.5
Intersection LOS:	B
Intersection Capacity Utilization:	48.3%
ICU Level of Service:	A
Analysis Period (min):	15

Splits and Phases: 6: Conde Lane & Shiloh Road

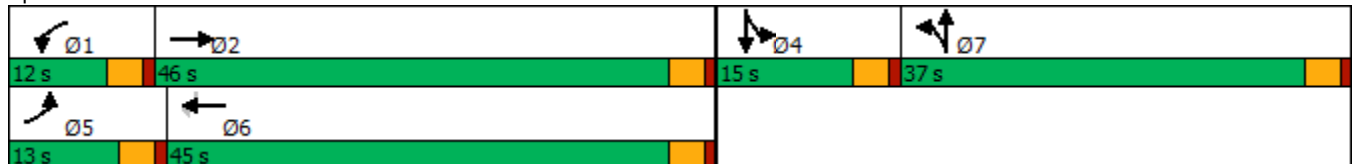

Lanes, Volumes, Timings  
7: Driveway 1/Gridley Drive & Shiloh Road





















Existing Project Alter. A Conditions  
Timing Plan: Saturday Midday Peak

Lane Group	EBL	EBT	EBR	WBL	WBT	WBR	NBL	NBT	NBR	SBL	SBT	SBR
Lane Configurations												
Traffic Volume (vph)	20	448	112	0	447	0	116	0	0	0	0	18
Future Volume (vph)	20	448	112	0	447	0	116	0	0	0	0	18
Ideal Flow (vphpl)	1900	1900	1900	1900	1900	1900	1900	1900	1900	1900	1900	1900
Storage Length (ft)	0		150	0		0	0		0	0		0
Storage Lanes	0		1	0		0	1		0	0		0
Taper Length (ft)	25			25			25			25		
Lane Util. Factor	1.00	1.00	1.00	1.00	1.00	1.00	1.00	1.00	1.00	1.00	1.00	1.00
Ped Bike Factor												
Frt			0.850								0.865	
Flt Protected		0.998					0.950					
Satd. Flow (prot)	0	1859	1583	0	1863	0	1770	1863	0	0	1611	0
Flt Permitted		0.998					0.950					
Satd. Flow (perm)	0	1859	1583	0	1863	0	1770	1863	0	0	1611	0
Link Speed (mph)		40			40			30			30	
Link Distance (ft)		608			2146			248			715	
Travel Time (s)		10.4			36.6			5.6			16.3	
Confl. Peds. (#/hr)	1											
Confl. Bikes (#/hr)			1			3						
Peak Hour Factor	0.93	0.93	0.93	0.88	0.88	0.88	1.00	1.00	1.00	0.56	0.56	0.56
Adj. Flow (vph)	22	482	120	0	508	0	116	0	0	0	0	32
Shared Lane Traffic (%)												
Lane Group Flow (vph)	0	504	120	0	508	0	116	0	0	0	32	0
Enter Blocked Intersection	No	No	No	No	No	No	No	No	No	No	No	No
Lane Alignment	Left	Left	Right	Left	Left	Right	Left	Left	Right	Left	Left	Right
Median Width(ft)		0			0			12			12	
Link Offset(ft)		0			0			0			0	
Crosswalk Width(ft)		16			16			16			16	
Two way Left Turn Lane												
Headway Factor	1.00	1.00	1.00	1.00	1.00	1.00	1.00	1.00	1.00	1.00	1.00	1.00
Turning Speed (mph)	15		9	15		9	15		9	15		9
Sign Control		Free			Free			Stop			Stop	

Intersection Summary	
Area Type:	Other
Control Type:	Unsignalized
Intersection Capacity Utilization	59.6%
Analysis Period (min)	15
	ICU Level of Service B

Lanes, Volumes, Timings  
8: Old Redwood Hwy & Driveway 2

Existing Project Alter. A Conditions  
Timing Plan: Saturday Midday Peak

												
Lane Group	EBL	EBT	EBR	WBL	WBT	WBR	NBL	NBT	NBR	SBL	SBT	SBR
Lane Configurations												
Traffic Volume (vph)	1	0	2	68	0	109	1	403	66	105	342	4
Future Volume (vph)	1	0	2	68	0	109	1	403	66	105	342	4
Ideal Flow (vphpl)	1900	1900	1900	1900	1900	1900	1900	1900	1900	1900	1900	1900
Storage Length (ft)	0		0	0		0	0		100	50		0
Storage Lanes	0		0	1		0	0		1	1		0
Taper Length (ft)	25			25			25			25		
Lane Util. Factor	1.00	1.00	1.00	1.00	1.00	1.00	1.00	1.00	1.00	1.00	1.00	1.00
Ped Bike Factor												
Frt		0.916			0.850				0.850		0.998	
Flt Protected		0.982		0.950						0.950		
Satd. Flow (prot)	0	1676	0	1770	1583	0	0	1863	1583	1770	1859	0
Flt Permitted		0.982		0.950						0.950		
Satd. Flow (perm)	0	1676	0	1770	1583	0	0	1863	1583	1770	1859	0
Link Speed (mph)		30			30			45			45	
Link Distance (ft)		98			385			520			748	
Travel Time (s)		2.2			8.8			7.9			11.3	
Confl. Peds. (#/hr)							1		4	4		1
Confl. Bikes (#/hr)									3			9
Peak Hour Factor	0.38	0.38	0.38	1.00	1.00	1.00	0.94	0.94	0.94	0.93	0.93	0.93
Adj. Flow (vph)	3	0	5	68	0	109	1	429	70	113	368	4
Shared Lane Traffic (%)												
Lane Group Flow (vph)	0	8	0	68	109	0	0	430	70	113	372	0
Enter Blocked Intersection	No	No	No	No	No	No	No	No	No	No	No	No
Lane Alignment	Left	Left	Right	Left	Left	Right	Left	Left	Right	Left	Left	Right
Median Width(ft)		12			12			12			12	
Link Offset(ft)		0			0			0			0	
Crosswalk Width(ft)		16			16			16			16	
Two way Left Turn Lane												
Headway Factor	1.00	1.00	1.00	1.00	1.00	1.00	1.00	1.00	1.00	1.00	1.00	1.00
Turning Speed (mph)	15		9	15		9	15		9	15		9
Sign Control		Stop			Stop			Free			Free	
<b>Intersection Summary</b>												
Area Type:	Other											
Control Type:	Unsignalized											
Intersection Capacity Utilization	58.9%						ICU Level of Service B					
Analysis Period (min)	15											

Lanes, Volumes, Timings  
9: Driveway 3 & Shiloh Road

Existing Project Alter. A Conditions  
Timing Plan: Saturday Midday Peak



Lane Group	EBT	EBR	WBL	WBT	NBL	NBR
Lane Configurations	↑	↑		↑	↑	↑
Traffic Volume (vph)	92	342	32	86	355	34
Future Volume (vph)	92	342	32	86	355	34
Ideal Flow (vphp)	1900	1900	1900	1900	1900	1900
Storage Length (ft)		200	0		0	0
Storage Lanes		1	0		1	1
Taper Length (ft)			25		25	
Lane Util. Factor	1.00	1.00	1.00	1.00	1.00	1.00
Ped Bike Factor						
Frt		0.850				0.850
Flt Protected				0.987	0.950	
Satd. Flow (prot)	1863	1583	0	1839	1770	1583
Flt Permitted				0.987	0.950	
Satd. Flow (perm)	1863	1583	0	1839	1770	1583
Link Speed (mph)	40			40	30	
Link Distance (ft)	2146			134	402	
Travel Time (s)	36.6			2.3	9.1	
Confl. Peds. (#/hr)		1				
Peak Hour Factor	0.88	0.88	0.80	0.80	1.00	1.00
Adj. Flow (vph)	105	389	40	108	355	34
Shared Lane Traffic (%)						
Lane Group Flow (vph)	105	389	0	148	355	34
Enter Blocked Intersection	No	No	No	No	No	No
Lane Alignment	Left	Right	Left	Left	Left	Right
Median Width(ft)	0			0	12	
Link Offset(ft)	0			0	0	
Crosswalk Width(ft)	16			16	16	
Two way Left Turn Lane						
Headway Factor	1.00	1.00	1.00	1.00	1.00	1.00
Turning Speed (mph)		9	15		15	9
Sign Control	Free			Free	Stop	
<b>Intersection Summary</b>						
Area Type:	Other					
Control Type:	Unsignalized					
Intersection Capacity Utilization	39.3%			ICU Level of Service A		
Analysis Period (min)	15					

Lanes, Volumes, Timings

Existing Project Alter. A Conditions

10: US 101 NB Off Ramp/Lakewood Drive & Old Redwood Highway Timing Plan: Saturday Midday Peak



Lane Group	EBL	EBT	EBR	WBL	WBT	WBR	NBL	NBT	NBR	SBL	SBT	SBR
Lane Configurations												
Traffic Volume (vph)	252	341	0	0	509	242	281	266	125	214	0	615
Future Volume (vph)	252	341	0	0	509	242	281	266	125	214	0	615
Ideal Flow (vphpl)	1900	1900	1900	1900	1900	1900	1900	1900	1900	1900	1900	1900
Storage Length (ft)	155		0	0		0	270		150	120		0
Storage Lanes	1		0	0		0	1		1	1		1
Taper Length (ft)	50			25			165			75		
Lane Util. Factor	0.97	1.00	1.00	1.00	0.95	0.95	0.91	0.91	0.95	0.97	1.00	1.00
Ped Bike Factor	1.00				0.99			1.00		1.00		
Fr <sub>t</sub>					0.952			0.958				0.850
Fl <sub>t</sub> Protected	0.950						0.950	0.994		0.950		
Satd. Flow (prot)	3433	1863	0	0	3352	0	1610	3217	0	3433	0	1583
Fl <sub>t</sub> Permitted	0.950						0.950	0.994		0.950		
Satd. Flow (perm)	3429	1863	0	0	3352	0	1610	3217	0	3430	0	1583
Right Turn on Red			Yes			Yes			Yes			Yes
Satd. Flow (RTOR)					92			61				293
Link Speed (mph)		35			35			30				30
Link Distance (ft)		226			617			716				478
Travel Time (s)		4.4			12.0			16.3				10.9
Confl. Peds. (#/hr)	2		1	1		2			1	1		
Confl. Bikes (#/hr)			10			3						
Peak Hour Factor	0.95	0.95	0.95	0.89	0.89	0.89	0.98	0.98	0.98	0.88	0.88	0.88
Adj. Flow (vph)	265	359	0	0	572	272	287	271	128	243	0	699
Shared Lane Traffic (%)							20%					
Lane Group Flow (vph)	265	359	0	0	844	0	230	456	0	243	0	699
Enter Blocked Intersection	No	No	No	No	No	No	No	No	No	No	No	No
Lane Alignment	Left	Left	Right	Left	Left	Right	Left	Left	Right	Left	Left	Right
Median Width(ft)		24			24			24				24
Link Offset(ft)		0			0			0				0
Crosswalk Width(ft)		16			16			16				16
Two way Left Turn Lane												
Headway Factor	1.00	1.00	1.00	1.00	1.00	1.00	1.00	1.00	1.00	1.00	1.00	1.00
Turning Speed (mph)	15		9	15		9	15		9	15		9
Number of Detectors	1	2			2		1	2		1		1
Detector Template	Left	Thru			Thru		Left	Thru		Left		Right
Leading Detector (ft)	20	100			100		20	100		20		20
Trailing Detector (ft)	0	0			0		0	0		0		0
Detector 1 Position(ft)	0	0			0		0	0		0		0
Detector 1 Size(ft)	20	6			6		20	6		20		20
Detector 1 Type	Cl+Ex	Cl+Ex			Cl+Ex		Cl+Ex	Cl+Ex		Cl+Ex		Cl+Ex
Detector 1 Channel												
Detector 1 Extend (s)	0.0	0.0			0.0		0.0	0.0		0.0		0.0
Detector 1 Queue (s)	0.0	0.0			0.0		0.0	0.0		0.0		0.0
Detector 1 Delay (s)	0.0	0.0			0.0		0.0	0.0		0.0		0.0
Detector 2 Position(ft)		94			94			94				
Detector 2 Size(ft)		6			6			6				
Detector 2 Type		Cl+Ex			Cl+Ex			Cl+Ex				
Detector 2 Channel												
Detector 2 Extend (s)		0.0			0.0			0.0				

Lanes, Volumes, Timings

Existing Project Alter. A Conditions

10: US 101 NB Off Ramp/Lakewood Drive & Old Redwood Highway Timing Plan: Saturday Midday Peak



Lane Group	EBL	EBT	EBR	WBL	WBT	WBR	NBL	NBT	NBR	SBL	SBT	SBR
Turn Type	Prot	NA			NA		Split	NA		Prot		pm+ov
Protected Phases	5	2			6		8	8		7		5
Permitted Phases												5 8
Detector Phase	5	2			6		8	8		7		5
Switch Phase												
Minimum Initial (s)	7.0	10.0			10.0		10.0	10.0		7.0		7.0
Minimum Split (s)	11.0	32.1			32.1		33.7	33.7		11.0		11.0
Total Split (s)	12.0	45.3			33.3		33.7	33.7		11.0		12.0
Total Split (%)	13.3%	50.3%			37.0%		37.4%	37.4%		12.2%		13.3%
Maximum Green (s)	8.0	40.2			28.2		29.0	29.0		7.0		8.0
Yellow Time (s)	3.0	4.1			4.1		3.7	3.7		3.0		3.0
All-Red Time (s)	1.0	1.0			1.0		1.0	1.0		1.0		1.0
Lost Time Adjust (s)	0.0	0.0			0.0		0.0	0.0		0.0		0.0
Total Lost Time (s)	4.0	5.1			5.1		4.7	4.7		4.0		4.0
Lead/Lag	Lead				Lag		Lag	Lag		Lead		Lead
Lead-Lag Optimize?	Yes				Yes		Yes	Yes		Yes		Yes
Vehicle Extension (s)	3.0	3.0			3.0		3.0	3.0		3.0		3.0
Recall Mode	None	Max			Max		None	None		None		None
Walk Time (s)		7.0			7.0		7.0	7.0				
Flash Dont Walk (s)		20.0			17.0		22.0	22.0				
Pedestrian Calls (#/hr)		0			0		0	0				
Act Effct Green (s)	8.0	40.4			28.4		18.0	18.0		7.0		30.8
Actuated g/C Ratio	0.10	0.51			0.36		0.23	0.23		0.09		0.39
v/c Ratio	0.76	0.38			0.67		0.63	0.59		0.80		0.88
Control Delay	52.0	14.5			23.2		35.3	26.2		57.8		26.7
Queue Delay	0.0	0.0			0.0		0.0	0.0		0.0		0.0
Total Delay	52.0	14.5			23.2		35.3	26.2		57.8		26.7
LOS	D	B			C		D	C		E		C
Approach Delay		30.4			23.2			29.3				34.7
Approach LOS		C			C			C				C

Intersection Summary

Area Type: Other  
 Cycle Length: 90  
 Actuated Cycle Length: 79.4  
 Natural Cycle: 90  
 Control Type: Actuated-Uncoordinated  
 Maximum v/c Ratio: 0.88  
 Intersection Signal Delay: 29.5  
 Intersection LOS: C  
 Intersection Capacity Utilization 84.9%  
 ICU Level of Service E  
 Analysis Period (min) 15

Splits and Phases: 10: US 101 NB Off Ramp/Lakewood Drive & Old Redwood Highway

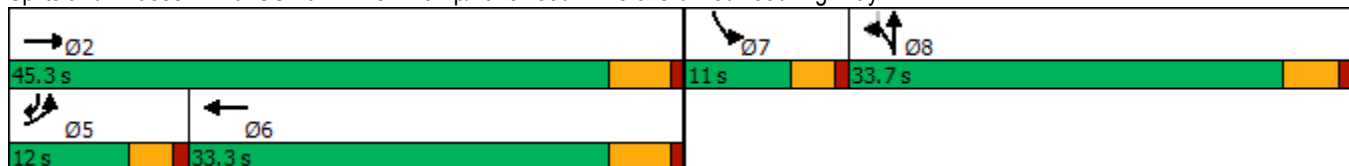



Lanes, Volumes, Timings  
 11: Old Redwood Highway & US 101 NB On Ramp

Existing Project Alter. A Conditions  
 Timing Plan: Saturday Midday Peak



Lane Group	EBL	EBT	WBT	WBR	SBL	SBR
Lane Configurations						
Traffic Volume (vph)	76	597	1150	189	0	0
Future Volume (vph)	76	597	1150	189	0	0
Ideal Flow (vphpl)	1900	1900	1900	1900	1900	1900
Storage Length (ft)	245			0	0	0
Storage Lanes	1			0	0	0
Taper Length (ft)	50				25	
Lane Util. Factor	1.00	0.95	0.95	0.95	1.00	1.00
Ped Bike Factor						
Frt			0.979			
Flt Protected	0.950					
Satd. Flow (prot)	1770	3539	3465	0	0	0
Flt Permitted	0.950					
Satd. Flow (perm)	1770	3539	3465	0	0	0
Link Speed (mph)		35	35		30	
Link Distance (ft)		531	226		299	
Travel Time (s)		10.3	4.4		6.8	
Confl. Peds. (#/hr)	8			8		
Confl. Bikes (#/hr)				4		
Peak Hour Factor	0.96	0.96	0.92	0.92	0.25	0.25
Adj. Flow (vph)	79	622	1250	205	0	0
Shared Lane Traffic (%)						
Lane Group Flow (vph)	79	622	1455	0	0	0
Enter Blocked Intersection	No	No	No	No	No	No
Lane Alignment	Left	Left	Left	Right	Left	Right
Median Width(ft)		12	12		0	
Link Offset(ft)		0	0		0	
Crosswalk Width(ft)		16	16		16	
Two way Left Turn Lane						
Headway Factor	1.00	1.00	1.00	1.00	1.00	1.00
Turning Speed (mph)	15			9	15	9
Sign Control		Free	Free		Free	

Intersection Summary	
Area Type:	Other
Control Type:	Unsignalized
Intersection Capacity Utilization	66.6% ICU Level of Service C
Analysis Period (min)	15

Lanes, Volumes, Timings

Existing Project Alter. A Conditions

12: US 101 SB On Ramp/US 101 SB Off Ramp & Old Redwood Highway Timing Plan: Saturday Midday Peak



Lane Group	EBL	EBT	EBR	WBL	WBT	WBR	NBL	NBT	NBR	SBL	SBT	SBR
Lane Configurations		↑↑	↗	↖	↑↑					↖	↕	
Traffic Volume (vph)	0	483	368	428	718	0	0	0	0	199	1	76
Future Volume (vph)	0	483	368	428	718	0	0	0	0	199	1	76
Ideal Flow (vphpl)	1900	1900	1900	1900	1900	1900	1900	1900	1900	1900	1900	1900
Storage Length (ft)	0		0	250		0	0		0	420		0
Storage Lanes	0		1	0		0	0		0	1		0
Taper Length (ft)	25			165			25			75		
Lane Util. Factor	1.00	0.95	1.00	1.00	0.95	1.00	1.00	1.00	1.00	0.95	0.95	1.00
Ped Bike Factor			0.98	1.00								
Frt			0.850								0.914	
Flt Protected				0.950						0.950	0.980	
Satd. Flow (prot)	0	3539	1583	1770	3539	0	0	0	0	1681	1585	0
Flt Permitted				0.950						0.950	0.980	
Satd. Flow (perm)	0	3539	1553	1768	3539	0	0	0	0	1681	1585	0
Right Turn on Red			Yes			Yes			Yes			Yes
Satd. Flow (RTOR)			379								82	
Link Speed (mph)		35			35			30			30	
Link Distance (ft)		423			531			621			831	
Travel Time (s)		8.2			10.3			14.1			18.9	
Confl. Peds. (#/hr)	11		2	2		11						
Confl. Bikes (#/hr)			10			2						
Peak Hour Factor	0.97	0.97	0.97	0.96	0.96	0.96	0.25	0.25	0.25	0.72	0.72	0.72
Adj. Flow (vph)	0	498	379	446	748	0	0	0	0	276	1	106
Shared Lane Traffic (%)										28%		
Lane Group Flow (vph)	0	498	379	446	748	0	0	0	0	199	184	0
Enter Blocked Intersection	No	No	No	No	No	No	No	No	No	No	No	No
Lane Alignment	Left	Left	Right	Left	Left	Right	Left	Left	Right	Left	Left	Right
Median Width(ft)		24			24			12			12	
Link Offset(ft)		0			0			0			0	
Crosswalk Width(ft)		16			16			16			16	
Two way Left Turn Lane												
Headway Factor	1.00	1.00	1.00	1.00	1.00	1.00	1.00	1.00	1.00	1.00	1.00	1.00
Turning Speed (mph)	15		9	15		9	15		9	15		9
Number of Detectors		2	1	1	2					1	2	
Detector Template		Thru	Right	Left	Thru					Left	Thru	
Leading Detector (ft)		100	20	20	100					20	100	
Trailing Detector (ft)		0	0	0	0					0	0	
Detector 1 Position(ft)		0	0	0	0					0	0	
Detector 1 Size(ft)		6	20	20	6					20	6	
Detector 1 Type		Cl+Ex	Cl+Ex	Cl+Ex	Cl+Ex					Cl+Ex	Cl+Ex	
Detector 1 Channel												
Detector 1 Extend (s)		0.0	0.0	0.0	0.0					0.0	0.0	
Detector 1 Queue (s)		0.0	0.0	0.0	0.0					0.0	0.0	
Detector 1 Delay (s)		0.0	0.0	0.0	0.0					0.0	0.0	
Detector 2 Position(ft)		94			94							94
Detector 2 Size(ft)		6			6							6
Detector 2 Type		Cl+Ex			Cl+Ex							Cl+Ex
Detector 2 Channel												
Detector 2 Extend (s)		0.0			0.0							0.0

Lanes, Volumes, Timings

Existing Project Alter. A Conditions

12: US 101 SB On Ramp/US 101 SB Off Ramp & Old Redwood Highway Timing Plan: Saturday Midday Peak



Lane Group	EBL	EBT	EBR	WBL	WBT	WBR	NBL	NBT	NBR	SBL	SBT	SBR
Turn Type		NA	Perm	Prot	NA					Perm	NA	
Protected Phases		6		5	2							8
Permitted Phases			6							8		
Detector Phase		6	6	5	2					8		8
Switch Phase												
Minimum Initial (s)		10.0	10.0	7.0	10.0					10.0	10.0	
Minimum Split (s)		32.1	32.1	11.0	38.1					14.7	14.7	
Total Split (s)		32.3	32.3	23.0	55.3					14.7	14.7	
Total Split (%)		46.1%	46.1%	32.9%	79.0%					21.0%	21.0%	
Maximum Green (s)		27.2	27.2	19.0	50.2					10.0	10.0	
Yellow Time (s)		4.1	4.1	3.0	4.1					3.7	3.7	
All-Red Time (s)		1.0	1.0	1.0	1.0					1.0	1.0	
Lost Time Adjust (s)		0.0	0.0	0.0	0.0					0.0	0.0	
Total Lost Time (s)		5.1	5.1	4.0	5.1					4.7	4.7	
Lead/Lag		Lag	Lag	Lead								
Lead-Lag Optimize?		Yes	Yes	Yes								
Vehicle Extension (s)		3.0	3.0	3.0	3.0					3.0	3.0	
Recall Mode		Max	Max	None	Max					None	None	
Walk Time (s)		7.0	7.0		7.0							
Flash Dont Walk (s)		20.0	20.0		25.0							
Pedestrian Calls (#/hr)		0	0		0							
Act Effct Green (s)		27.3	27.3	18.9	50.2					10.0	10.0	
Actuated g/C Ratio		0.39	0.39	0.27	0.72					0.14	0.14	
v/c Ratio		0.36	0.45	0.94	0.29					0.83	0.62	
Control Delay		16.1	3.8	55.6	3.9					59.3	26.6	
Queue Delay		0.0	0.0	0.0	0.0					0.0	0.0	
Total Delay		16.1	3.8	55.6	3.9					59.3	26.6	
LOS		B	A	E	A					E	C	
Approach Delay		10.8			23.2							43.6
Approach LOS		B			C							D

Intersection Summary

Area Type:	Other
Cycle Length:	70
Actuated Cycle Length:	70
Natural Cycle:	75
Control Type:	Actuated-Uncoordinated
Maximum v/c Ratio:	0.94
Intersection Signal Delay:	22.0
Intersection LOS:	C
Intersection Capacity Utilization:	66.6%
ICU Level of Service:	C
Analysis Period (min):	15

Splits and Phases: 12: US 101 SB On Ramp/US 101 SB Off Ramp & Old Redwood Highway

























Appendix D – Existing plus Alternative B Project Conditions  
Intersection Level of Service Worksheets

---

---

HCM 6th Signalized Intersection Summary  
 1: Old Redwood Hwy & Shiloh Road

Existing Project Alter. B Conditions  
 Timing Plan: A.M. PEAK

												
Movement	EBL	EBT	EBR	WBL	WBT	WBR	NBL	NBT	NBR	SBL	SBT	SBR
Lane Configurations												
Traffic Volume (veh/h)	108	274	104	22	171	26	92	125	34	35	234	169
Future Volume (veh/h)	108	274	104	22	171	26	92	125	34	35	234	169
Initial Q (Qb), veh	0	0	0	0	0	0	0	0	0	0	0	0
Ped-Bike Adj(A_pbT)	1.00		1.00	1.00		1.00	1.00		1.00	1.00		0.98
Parking Bus, Adj	1.00	1.00	1.00	1.00	1.00	1.00	1.00	1.00	1.00	1.00	1.00	1.00
Work Zone On Approach		No			No			No			No	
Adj Sat Flow, veh/h/ln	1870	1870	1870	1870	1870	1870	1870	1870	1870	1870	1870	1870
Adj Flow Rate, veh/h	133	338	128	25	192	29	99	134	37	41	275	199
Peak Hour Factor	0.81	0.81	0.81	0.89	0.89	0.89	0.93	0.93	0.93	0.85	0.85	0.85
Percent Heavy Veh, %	2	2	2	2	2	2	2	2	2	2	2	2
Cap, veh/h	436	458	388	35	269	259	160	397	336	154	390	323
Arrive On Green	0.24	0.24	0.24	0.16	0.16	0.16	0.09	0.21	0.21	0.09	0.21	0.21
Sat Flow, veh/h	1781	1870	1585	214	1645	1585	1781	1870	1585	1781	1870	1551
Grp Volume(v), veh/h	133	338	128	217	0	29	99	134	37	41	275	199
Grp Sat Flow(s),veh/h/ln	1781	1870	1585	1860	0	1585	1781	1870	1585	1781	1870	1551
Q Serve(g_s), s	3.5	9.7	3.8	6.4	0.0	0.9	3.1	3.5	1.1	1.2	7.9	6.8
Cycle Q Clear(g_c), s	3.5	9.7	3.8	6.4	0.0	0.9	3.1	3.5	1.1	1.2	7.9	6.8
Prop In Lane	1.00		1.00	0.12		1.00	1.00		1.00	1.00		1.00
Lane Grp Cap(c), veh/h	436	458	388	304	0	259	160	397	336	154	390	323
V/C Ratio(X)	0.30	0.74	0.33	0.71	0.00	0.11	0.62	0.34	0.11	0.27	0.70	0.62
Avail Cap(c_a), veh/h	937	984	834	1219	0	1039	446	1403	1189	184	1129	936
HCM Platoon Ratio	1.00	1.00	1.00	1.00	1.00	1.00	1.00	1.00	1.00	1.00	1.00	1.00
Upstream Filter(I)	1.00	1.00	1.00	1.00	0.00	1.00	1.00	1.00	1.00	1.00	1.00	1.00
Uniform Delay (d), s/veh	17.9	20.2	18.0	23.0	0.0	20.7	25.4	19.4	18.4	24.8	21.3	20.8
Incr Delay (d2), s/veh	0.4	2.3	0.5	3.1	0.0	0.2	3.9	0.5	0.1	0.9	2.3	1.9
Initial Q Delay(d3),s/veh	0.0	0.0	0.0	0.0	0.0	0.0	0.0	0.0	0.0	0.0	0.0	0.0
%ile BackOfQ(50%),veh/ln	1.3	3.9	1.2	2.8	0.0	0.3	1.3	1.4	0.4	0.5	3.3	2.3
Unsig. Movement Delay, s/veh												
LnGrp Delay(d),s/veh	18.2	22.5	18.5	26.1	0.0	20.8	29.3	19.9	18.6	25.7	23.6	22.7
LnGrp LOS	B	C	B	C	A	C	C	B	B	C	C	C
Approach Vol, veh/h		599			246			270			515	
Approach Delay, s/veh		20.7			25.5			23.2			23.4	
Approach LOS		C			C			C			C	
Timer - Assigned Phs		2	3	4		6	7	8				
Phs Duration (G+Y+Rc), s		18.7	8.7	16.6		14.0	8.5	16.8				
Change Period (Y+Rc), s		4.5	3.5	4.5		4.5	3.5	4.5				
Max Green Setting (Gmax), s		30.5	14.5	35.0		38.0	6.0	43.5				
Max Q Clear Time (g_c+I1), s		11.7	5.1	9.9		8.4	3.2	5.5				
Green Ext Time (p_c), s		2.5	0.1	2.2		1.3	0.0	0.8				
<b>Intersection Summary</b>												
HCM 6th Ctrl Delay				22.7								
HCM 6th LOS				C								

# HCM Signalized Intersection Capacity Analysis

## 2: Shiloh Road & Hembree Ln

Existing Project Alter. B Conditions  
Timing Plan: A.M. PEAK

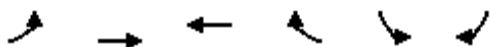

Movement	EBL	EBT	WBT	WBR	SBL	SBR
Lane Configurations	↶ ↷	↷	↶ ↷		↶ ↷	↶ ↷
Traffic Volume (vph)	305	434	392	68	71	361
Future Volume (vph)	305	434	392	68	71	361
Ideal Flow (vphpl)	1900	1900	1900	1900	1900	1900
Total Lost time (s)	4.0	4.0	4.0		4.0	4.0
Lane Util. Factor	0.97	1.00	0.95		1.00	1.00
Frt	1.00	1.00	0.98		1.00	0.85
Flt Protected	0.95	1.00	1.00		0.95	1.00
Satd. Flow (prot)	3433	1863	3461		1770	1583
Flt Permitted	0.95	1.00	1.00		0.95	1.00
Satd. Flow (perm)	3433	1863	3461		1770	1583
Peak-hour factor, PHF	0.88	0.88	0.97	0.97	0.94	0.94
Adj. Flow (vph)	347	493	404	70	76	384
RTOR Reduction (vph)	0	0	19	0	0	209
Lane Group Flow (vph)	347	493	455	0	76	175
Turn Type	Prot	NA	NA		Perm	pm+ov
Protected Phases	5	2	6			5
Permitted Phases					4	4 5
Actuated Green, G (s)	10.8	27.2	12.4		4.1	14.9
Effective Green, g (s)	10.8	27.2	12.4		4.1	14.9
Actuated g/C Ratio	0.27	0.69	0.32		0.10	0.38
Clearance Time (s)	4.0	4.0	4.0		4.0	4.0
Vehicle Extension (s)	3.0	3.0	3.0		3.0	3.0
Lane Grp Cap (vph)	943	1289	1092		184	761
v/s Ratio Prot	0.10	c0.26	0.13			0.06
v/s Ratio Perm					c0.04	0.05
v/c Ratio	0.37	0.38	0.42		0.41	0.23
Uniform Delay, d1	11.5	2.5	10.6		16.5	8.3
Progression Factor	1.00	1.00	1.00		1.00	1.00
Incremental Delay, d2	0.2	0.2	0.3		1.5	0.2
Delay (s)	11.7	2.7	10.9		18.0	8.5
Level of Service	B	A	B		B	A
Approach Delay (s)		6.4	10.9		10.0	
Approach LOS		A	B		B	

### Intersection Summary

HCM 2000 Control Delay	8.6	HCM 2000 Level of Service	A
HCM 2000 Volume to Capacity ratio	0.44		
Actuated Cycle Length (s)	39.3	Sum of lost time (s)	12.0
Intersection Capacity Utilization	42.0%	ICU Level of Service	A
Analysis Period (min)	15		

c Critical Lane Group

HCM 6th Signalized Intersection Summary  
 3: US 101 NB Off-Ramp & Shiloh Road

Existing Project Alter. B Conditions  
 Timing Plan: A.M. PEAK

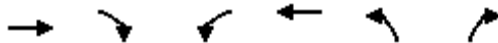

Movement	EBT	EBR	WBL	WBT	NBL	NBR
Lane Configurations	↑↑			↑	↘	↗
Traffic Volume (veh/h)	301	0	0	581	432	451
Future Volume (veh/h)	301	0	0	581	432	451
Initial Q (Qb), veh	0	0	0	0	0	0
Ped-Bike Adj(A_pbT)		1.00	1.00		1.00	1.00
Parking Bus, Adj	1.00	1.00	1.00	1.00	1.00	1.00
Work Zone On Approach	No			No	No	
Adj Sat Flow, veh/h/ln	1870	0	0	1870	1870	1870
Adj Flow Rate, veh/h	331	0	0	646	568	593
Peak Hour Factor	0.91	0.91	0.90	0.90	0.76	0.76
Percent Heavy Veh, %	2	0	0	2	2	2
Cap, veh/h	1507	0	0	793	727	1139
Arrive On Green	0.42	0.00	0.00	0.42	0.41	0.41
Sat Flow, veh/h	3741	0	0	1870	1781	2790
Grp Volume(v), veh/h	331	0	0	646	568	593
Grp Sat Flow(s),veh/h/ln	1777	0	0	1870	1781	1395
Q Serve(g_s), s	2.8	0.0	0.0	14.5	13.2	7.6
Cycle Q Clear(g_c), s	2.8	0.0	0.0	14.5	13.2	7.6
Prop In Lane		0.00	0.00		1.00	1.00
Lane Grp Cap(c), veh/h	1507	0	0	793	727	1139
V/C Ratio(X)	0.22	0.00	0.00	0.81	0.78	0.52
Avail Cap(c_a), veh/h	2455	0	0	1292	1156	1811
HCM Platoon Ratio	1.00	1.00	1.00	1.00	1.00	1.00
Upstream Filter(I)	1.00	0.00	0.00	1.00	1.00	1.00
Uniform Delay (d), s/veh	8.7	0.0	0.0	12.1	12.3	10.6
Incr Delay (d2), s/veh	0.1	0.0	0.0	2.1	1.9	0.4
Initial Q Delay(d3),s/veh	0.0	0.0	0.0	0.0	0.0	0.0
%ile BackOfQ(50%),veh/ln	0.8	0.0	0.0	4.7	4.5	1.9
Unsig. Movement Delay, s/veh						
LnGrp Delay(d),s/veh	8.8	0.0	0.0	14.2	14.1	11.0
LnGrp LOS	A	A	A	B	B	B
Approach Vol, veh/h	331			646	1161	
Approach Delay, s/veh	8.8			14.2	12.5	
Approach LOS	A			B	B	
Timer - Assigned Phs		2			6	8
Phs Duration (G+Y+Rc), s		24.3			24.3	23.5
Change Period (Y+Rc), s		4.0			4.0	4.0
Max Green Setting (Gmax), s		33.0			33.0	31.0
Max Q Clear Time (g_c+I1), s		4.8			16.5	15.2
Green Ext Time (p_c), s		2.1			3.8	4.3
<b>Intersection Summary</b>						
HCM 6th Ctrl Delay			12.5			
HCM 6th LOS			B			

HCM Signalized Intersection Capacity Analysis  
4: Shiloh Road & US 101 SB Off-Ramp

Existing Project Alter. B Conditions  
Timing Plan: A.M. PEAK



Movement	EBL	EBT	WBT	WBR	SBL	SBR
Lane Configurations		↑	↑		↘	↘
Traffic Volume (vph)	0	240	594	0	149	138
Future Volume (vph)	0	240	594	0	149	138
Ideal Flow (vphpl)	1900	1900	1900	1900	1900	1900
Total Lost time (s)		4.0	4.0		4.0	4.0
Lane Util. Factor		1.00	1.00		1.00	1.00
Frt		1.00	1.00		1.00	0.85
Flt Protected		1.00	1.00		0.95	1.00
Satd. Flow (prot)		1863	1863		1770	1583
Flt Permitted		1.00	1.00		0.95	1.00
Satd. Flow (perm)		1863	1863		1770	1583
Peak-hour factor, PHF	0.93	0.93	0.91	0.91	0.92	0.92
Adj. Flow (vph)	0	258	653	0	162	150
RTOR Reduction (vph)	0	0	0	0	0	113
Lane Group Flow (vph)	0	258	653	0	162	37
Turn Type		NA	NA		Perm	Perm
Protected Phases		2	6			
Permitted Phases					4	4
Actuated Green, G (s)		19.9	19.9		9.1	9.1
Effective Green, g (s)		19.9	19.9		9.1	9.1
Actuated g/C Ratio		0.54	0.54		0.25	0.25
Clearance Time (s)		4.0	4.0		4.0	4.0
Vehicle Extension (s)		3.0	3.0		3.0	3.0
Lane Grp Cap (vph)		1001	1001		435	389
v/s Ratio Prot		0.14	c0.35			
v/s Ratio Perm					c0.09	0.02
v/c Ratio		0.26	0.65		0.37	0.09
Uniform Delay, d1		4.6	6.1		11.6	10.8
Progression Factor		1.00	1.00		1.00	1.00
Incremental Delay, d2		0.1	1.5		0.5	0.1
Delay (s)		4.7	7.6		12.1	10.9
Level of Service		A	A		B	B
Approach Delay (s)		4.7	7.6		11.5	
Approach LOS		A	A		B	

Intersection Summary

HCM 2000 Control Delay	8.0	HCM 2000 Level of Service	A
HCM 2000 Volume to Capacity ratio	0.56		
Actuated Cycle Length (s)	37.0	Sum of lost time (s)	8.0
Intersection Capacity Utilization	60.1%	ICU Level of Service	B
Analysis Period (min)	15		

c Critical Lane Group



Intersection						
Int Delay, s/veh	2.6					
Movement	EBT	EBR	WBL	WBT	NBL	NBR
Lane Configurations	↑↑		↘	↑	↘	↘
Traffic Vol, veh/h	532	22	177	557	7	121
Future Vol, veh/h	532	22	177	557	7	121
Conflicting Peds, #/hr	0	0	0	0	0	0
Sign Control	Free	Free	Free	Free	Stop	Stop
RT Channelized	-	None	-	None	-	None
Storage Length	-	-	68	-	0	0
Veh in Median Storage, #	0	-	-	0	0	-
Grade, %	0	-	-	0	0	-
Peak Hour Factor	96	96	87	87	84	84
Heavy Vehicles, %	2	2	2	2	2	2
Mvmt Flow	554	23	203	640	8	144



















Major/Minor	Major1	Major2	Minor1		
Conflicting Flow All	0	0	577	0	1612 289
Stage 1	-	-	-	-	566 -
Stage 2	-	-	-	-	1046 -
Critical Hdwy	-	-	4.13	-	6.63 6.93
Critical Hdwy Stg 1	-	-	-	-	5.83 -
Critical Hdwy Stg 2	-	-	-	-	5.43 -
Follow-up Hdwy	-	-	2.219	-	3.519 3.319
Pot Cap-1 Maneuver	-	-	995	-	104 708
Stage 1	-	-	-	-	533 -
Stage 2	-	-	-	-	337 -
Platoon blocked, %	-	-	-	-	-
Mov Cap-1 Maneuver	-	-	995	-	83 708
Mov Cap-2 Maneuver	-	-	-	-	83 -
Stage 1	-	-	-	-	533 -
Stage 2	-	-	-	-	268 -

Approach	EB	WB	NB
HCM Control Delay, s	0	2.3	13.7
HCM LOS			B

Minor Lane/Major Mvmt	NBLn1	NBLn2	EBT	EBR	WBL	WBT
Capacity (veh/h)	83	708	-	-	995	-
HCM Lane V/C Ratio	0.1	0.203	-	-	0.204	-
HCM Control Delay (s)	53.2	11.4	-	-	9.5	-
HCM Lane LOS	F	B	-	-	A	-
HCM 95th %tile Q(veh)	0.3	0.8	-	-	0.8	-

HCM Signalized Intersection Capacity Analysis  
6: Conde Lane & Shiloh Road

Existing Project Alter. B Conditions  
Timing Plan: A.M. PEAK

													
Movement	EBL	EBT	EBR	WBL	WBT	WBR	NBL	NBT	NBR	SBL	SBT	SBR	
Lane Configurations													
Traffic Volume (vph)	25	337	5	9	361	204	4	0	12	205	1	35	
Future Volume (vph)	25	337	5	9	361	204	4	0	12	205	1	35	
Ideal Flow (vphpl)	1900	1900	1900	1900	1900	1900	1900	1900	1900	1900	1900	1900	
Total Lost time (s)	4.0	4.0		4.0	4.0			4.0			4.0	4.0	
Lane Util. Factor	1.00	0.95		1.00	0.95			1.00			1.00	1.00	
Frt	1.00	1.00		1.00	0.95			0.90			1.00	0.85	
Flt Protected	0.95	1.00		0.95	1.00			0.99			0.95	1.00	
Satd. Flow (prot)	1770	3532		1770	3348			1653			1774	1583	
Flt Permitted	0.95	1.00		0.95	1.00			0.99			0.95	1.00	
Satd. Flow (perm)	1770	3532		1770	3348			1653			1774	1583	
Peak-hour factor, PHF	0.95	0.95	0.95	0.85	0.85	0.85	0.57	0.57	0.57	0.86	0.86	0.86	
Adj. Flow (vph)	26	355	5	11	425	240	7	0	21	238	1	41	
RTOR Reduction (vph)	0	1	0	0	78	0	0	26	0	0	0	0	
Lane Group Flow (vph)	26	359	0	11	587	0	0	2	0	0	239	41	
Turn Type	Prot	NA		Prot	NA		Split	NA		Split	NA	custom	
Protected Phases	5	2		1	6		7	7		4	4		
Permitted Phases												6	
Actuated Green, G (s)	2.1	16.6		1.0	15.5			2.7			12.8	15.5	
Effective Green, g (s)	2.1	16.6		1.0	15.5			2.7			12.8	15.5	
Actuated g/C Ratio	0.04	0.34		0.02	0.32			0.05			0.26	0.32	
Clearance Time (s)	4.0	4.0		4.0	4.0			4.0			4.0	4.0	
Vehicle Extension (s)	3.0	3.0		3.0	3.0			3.0			3.0	3.0	
Lane Grp Cap (vph)	75	1194		36	1056			90			462	499	
v/s Ratio Prot	c0.01	0.10		0.01	c0.18			c0.00			c0.13		
v/s Ratio Perm												0.03	
v/c Ratio	0.35	0.30		0.31	0.56			0.02			0.52	0.08	
Uniform Delay, d1	22.8	12.0		23.7	13.9			21.9			15.5	11.8	
Progression Factor	1.00	1.00		1.00	1.00			1.00			1.00	1.00	
Incremental Delay, d2	2.8	0.1		4.8	0.6			0.1			1.0	0.1	
Delay (s)	25.6	12.1		28.5	14.6			22.0			16.5	11.9	
Level of Service	C	B		C	B			C			B	B	
Approach Delay (s)		13.0			14.8			22.0			15.8		
Approach LOS		B			B			C			B		
<b>Intersection Summary</b>													
HCM 2000 Control Delay			14.7									HCM 2000 Level of Service	B
HCM 2000 Volume to Capacity ratio			0.48										
Actuated Cycle Length (s)			49.1									Sum of lost time (s)	16.0
Intersection Capacity Utilization			45.5%									ICU Level of Service	A
Analysis Period (min)			15										

c Critical Lane Group

HCM 6th TWSC  
7: Driveway 1/Gridley Drive & Shiloh Road

Existing Project Alter. B Conditions  
Timing Plan: A.M. PEAK

Intersection												
Int Delay, s/veh	1.2											
Movement	EBL	EBT	EBR	WBL	WBT	WBR	NBL	NBT	NBR	SBL	SBT	SBR
Lane Configurations		↕	↕		↕		↕	↕			↕	
Traffic Vol, veh/h	8	286	47	0	159	0	33	0	0	1	0	16
Future Vol, veh/h	8	286	47	0	159	0	33	0	0	1	0	16
Conflicting Peds, #/hr	0	0	0	0	0	0	0	0	0	0	0	0
Sign Control	Free	Free	Free	Free	Free	Free	Stop	Stop	Stop	Stop	Stop	Stop
RT Channelized	-	-	None	-	-	None	-	-	None	-	-	None
Storage Length	-	-	150	-	-	-	0	-	-	-	-	-
Veh in Median Storage, #	-	0	-	-	0	-	-	0	-	-	0	-
Grade, %	-	0	-	-	0	-	-	0	-	-	0	-
Peak Hour Factor	91	91	91	85	85	85	100	100	100	71	71	71
Heavy Vehicles, %	2	2	2	2	2	2	2	2	2	2	2	2
Mvmt Flow	9	314	52	0	187	0	33	0	0	1	0	23

Major/Minor	Major1			Major2			Minor1			Minor2		
Conflicting Flow All	187	0	0	366	0	0	531	519	314	545	571	187
Stage 1	-	-	-	-	-	-	332	332	-	187	187	-
Stage 2	-	-	-	-	-	-	199	187	-	358	384	-
Critical Hdwy	4.12	-	-	4.12	-	-	7.12	6.52	6.22	7.12	6.52	6.22
Critical Hdwy Stg 1	-	-	-	-	-	-	6.12	5.52	-	6.12	5.52	-
Critical Hdwy Stg 2	-	-	-	-	-	-	6.12	5.52	-	6.12	5.52	-
Follow-up Hdwy	2.218	-	-	2.218	-	-	3.518	4.018	3.318	3.518	4.018	3.318
Pot Cap-1 Maneuver	1387	-	-	1193	-	-	459	461	726	449	431	855
Stage 1	-	-	-	-	-	-	681	644	-	815	745	-
Stage 2	-	-	-	-	-	-	803	745	-	660	611	-
Platoon blocked, %		-	-		-	-						
Mov Cap-1 Maneuver	1387	-	-	1193	-	-	444	457	726	446	428	855
Mov Cap-2 Maneuver	-	-	-	-	-	-	444	457	-	446	428	-
Stage 1	-	-	-	-	-	-	676	639	-	808	745	-
Stage 2	-	-	-	-	-	-	782	745	-	655	606	-

Approach	EB	WB	NB	SB
HCM Control Delay, s	0.2	0	13.8	9.6
HCM LOS			B	A

Minor Lane/Major Mvmt	NBLn1	NBLn2	EBL	EBT	EBR	WBL	WBT	WBR	SBLn1
Capacity (veh/h)	444	-	1387	-	-	1193	-	-	811
HCM Lane V/C Ratio	0.074	-	0.006	-	-	-	-	-	0.03
HCM Control Delay (s)	13.8	0	7.6	0	-	0	-	-	9.6
HCM Lane LOS	B	A	A	A	-	A	-	-	A
HCM 95th %tile Q(veh)	0.2	-	0	-	-	0	-	-	0.1

HCM 6th TWSC  
8: Old Redwood Hwy & Driveway 2

Existing Project Alter. B Conditions  
Timing Plan: A.M. PEAK

Intersection												
Int Delay, s/veh	1.5											
Movement	EBL	EBT	EBR	WBL	WBT	WBR	NBL	NBT	NBR	SBL	SBT	SBR
Lane Configurations		↕		↕	↕			↕	↕	↕	↕	
Traffic Vol, veh/h	1	0	0	19	0	31	0	217	28	45	316	0
Future Vol, veh/h	1	0	0	19	0	31	0	217	28	45	316	0
Conflicting Peds, #/hr	0	0	0	0	0	0	0	0	1	1	0	0
Sign Control	Stop	Stop	Stop	Stop	Stop	Stop	Free	Free	Free	Free	Free	Free
RT Channelized	-	-	None	-	-	None	-	-	None	-	-	None
Storage Length	-	-	-	0	-	-	-	-	100	50	-	-
Veh in Median Storage, #	-	0	-	-	0	-	-	0	-	-	0	-
Grade, %	-	0	-	-	0	-	-	0	-	-	0	-
Peak Hour Factor	25	25	25	100	100	100	99	99	99	90	90	90
Heavy Vehicles, %	2	2	2	2	2	2	2	2	2	2	2	2
Mvmt Flow	4	0	0	19	0	31	0	219	28	50	351	0

Major/Minor	Minor2		Minor1		Major1		Major2					
Conflicting Flow All	700	699	351	671	671	220	351	0	0	248	0	0
Stage 1	451	451	-	220	220	-	-	-	-	-	-	-
Stage 2	249	248	-	451	451	-	-	-	-	-	-	-
Critical Hdwy	7.12	6.52	6.22	7.12	6.52	6.22	4.12	-	-	4.12	-	-
Critical Hdwy Stg 1	6.12	5.52	-	6.12	5.52	-	-	-	-	-	-	-
Critical Hdwy Stg 2	6.12	5.52	-	6.12	5.52	-	-	-	-	-	-	-
Follow-up Hdwy	3.518	4.018	3.318	3.518	4.018	3.318	2.218	-	-	2.218	-	-
Pot Cap-1 Maneuver	354	364	692	370	378	820	1208	-	-	1318	-	-
Stage 1	588	571	-	782	721	-	-	-	-	-	-	-
Stage 2	755	701	-	588	571	-	-	-	-	-	-	-
Platoon blocked, %								-	-	-	-	-
Mov Cap-1 Maneuver	331	350	692	359	363	819	1208	-	-	1317	-	-
Mov Cap-2 Maneuver	331	350	-	359	363	-	-	-	-	-	-	-
Stage 1	588	549	-	781	720	-	-	-	-	-	-	-
Stage 2	726	700	-	566	549	-	-	-	-	-	-	-

Approach	EB	WB	NB	SB
HCM Control Delay, s	16	11.9	0	1
HCM LOS	C	B		

Minor Lane/Major Mvmt	NBL	NBT	NBR	EBLn1	WBLn1	WBLn2	SBL	SBT	SBR
Capacity (veh/h)	1208	-	-	331	359	819	1317	-	-
HCM Lane V/C Ratio	-	-	-	0.012	0.053	0.038	0.038	-	-
HCM Control Delay (s)	0	-	-	16	15.6	9.6	7.8	-	-
HCM Lane LOS	A	-	-	C	C	A	A	-	-
HCM 95th %tile Q(veh)	0	-	-	0	0.2	0.1	0.1	-	-

Intersection						
Int Delay, s/veh	2.5					
Movement	EBT	EBR	WBL	WBT	NBL	NBR
Lane Configurations	↑	↗		↖	↖	↗
Traffic Vol, veh/h	140	145	14	52	101	10
Future Vol, veh/h	140	145	14	52	101	10
Conflicting Peds, #/hr	0	0	0	0	0	0
Sign Control	Free	Free	Free	Free	Stop	Stop
RT Channelized	-	None	-	None	-	None
Storage Length	-	200	-	-	0	0
Veh in Median Storage, #	0	-	-	0	0	-
Grade, %	0	-	-	0	0	-
Peak Hour Factor	85	85	81	81	100	100
Heavy Vehicles, %	2	2	2	2	2	2
Mvmt Flow	165	171	17	64	101	10

Major/Minor	Major1	Major2	Minor1		
Conflicting Flow All	0	0	336	0	263
Stage 1	-	-	-	-	165
Stage 2	-	-	-	-	98
Critical Hdwy	-	-	4.12	-	6.42
Critical Hdwy Stg 1	-	-	-	-	5.42
Critical Hdwy Stg 2	-	-	-	-	5.42
Follow-up Hdwy	-	-	2.218	-	3.518
Pot Cap-1 Maneuver	-	-	1223	-	726
Stage 1	-	-	-	-	864
Stage 2	-	-	-	-	926
Platoon blocked, %	-	-	-	-	-
Mov Cap-1 Maneuver	-	-	1223	-	716
Mov Cap-2 Maneuver	-	-	-	-	716
Stage 1	-	-	-	-	864
Stage 2	-	-	-	-	913

Approach	EB	WB	NB
HCM Control Delay, s	0	1.7	10.7
HCM LOS			B

Minor Lane/Major Mvmt	NBLn1	NBLn2	EBT	EBR	WBL	WBT
Capacity (veh/h)	716	879	-	-	1223	-
HCM Lane V/C Ratio	0.141	0.011	-	-	0.014	-
HCM Control Delay (s)	10.9	9.1	-	-	8	0
HCM Lane LOS	B	A	-	-	A	A
HCM 95th %tile Q(veh)	0.5	0	-	-	0	-

HCM 6th Signalized Intersection Summary  
 10: US 101 NB Off Ramp/Lakewood Drive & Old Redwood Highway

Existing Project Alter. B Conditions  
 Timing Plan: A.M. PEAK



Movement	EBL	EBT	EBR	WBL	WBT	WBR	NBL	NBT	NBR	SBL	SBT	SBR
Lane Configurations	↔↔	↑			↑↑		↔	↔↔		↔↔		↔
Traffic Volume (veh/h)	152	177	0	0	459	149	227	221	79	118	0	534
Future Volume (veh/h)	152	177	0	0	459	149	227	221	79	118	0	534
Initial Q (Qb), veh	0	0	0	0	0	0	0	0	0	0	0	0
Ped-Bike Adj(A_pbT)	1.00		1.00	1.00		0.99	1.00		1.00	1.00		1.00
Parking Bus, Adj	1.00	1.00	1.00	1.00	1.00	1.00	1.00	1.00	1.00	1.00	1.00	1.00
Work Zone On Approach		No			No			No			No	
Adj Sat Flow, veh/h/ln	1870	1870	0	0	1870	1870	1870	1870	1870	1870	0	1870
Adj Flow Rate, veh/h	179	208	0	0	553	180	195	325	88	133	0	0
Peak Hour Factor	0.85	0.85	0.85	0.83	0.83	0.83	0.90	0.90	0.90	0.89	0.89	0.89
Percent Heavy Veh, %	2	2	0	0	2	2	2	2	2	2	0	2
Cap, veh/h	373	1215	0	0	1254	407	342	546	145	0	0	
Arrive On Green	0.11	0.65	0.00	0.00	0.48	0.48	0.19	0.19	0.19	0.00	0.00	0.00
Sat Flow, veh/h	3456	1870	0	0	2722	852	1781	2844	758		0	
Grp Volume(v), veh/h	179	208	0	0	373	360	195	212	201		0.0	
Grp Sat Flow(s),veh/h/ln	1728	1870	0	0	1777	1704	1781	1870	1731			
Q Serve(g_s), s	3.0	2.7	0.0	0.0	8.6	8.7	6.1	6.4	6.6			
Cycle Q Clear(g_c), s	3.0	2.7	0.0	0.0	8.6	8.7	6.1	6.4	6.6			
Prop In Lane	1.00		0.00	0.00		0.50	1.00		0.44			
Lane Grp Cap(c), veh/h	373	1215	0	0	848	813	342	359	332			
V/C Ratio(X)	0.48	0.17	0.00	0.00	0.44	0.44	0.57	0.59	0.61			
Avail Cap(c_a), veh/h	503	1215	0	0	848	813	835	877	811			
HCM Platoon Ratio	1.00	1.00	1.00	1.00	1.00	1.00	1.00	1.00	1.00			
Upstream Filter(I)	1.00	1.00	0.00	0.00	1.00	1.00	1.00	1.00	1.00			
Uniform Delay (d), s/veh	26.0	4.3	0.0	0.0	10.7	10.7	22.7	22.8	22.9			
Incr Delay (d2), s/veh	1.0	0.3	0.0	0.0	1.7	1.7	1.5	1.5	1.8			
Initial Q Delay(d3),s/veh	0.0	0.0	0.0	0.0	0.0	0.0	0.0	0.0	0.0			
%ile BackOfQ(50%),veh/ln	1.2	0.8	0.0	0.0	3.2	3.1	2.5	2.8	2.7			
Unsig. Movement Delay, s/veh												
LnGrp Delay(d),s/veh	26.9	4.6	0.0	0.0	12.4	12.5	24.2	24.3	24.6			
LnGrp LOS	C	A	A	A	B	B	C	C	C			
Approach Vol, veh/h		387			733			608				
Approach Delay, s/veh		14.9			12.4			24.4				
Approach LOS		B			B			C				
Timer - Assigned Phs		2			5	6		8				
Phs Duration (G+Y+Rc), s		45.3			10.7	34.6		16.6				
Change Period (Y+Rc), s		5.1			4.0	5.1		4.7				
Max Green Setting (Gmax), s		40.2			9.0	27.2		29.0				
Max Q Clear Time (g_c+I1), s		4.7			5.0	10.7		8.6				
Green Ext Time (p_c), s		1.2			0.2	4.2		3.0				

Intersection Summary

HCM 6th Ctrl Delay	17.2
HCM 6th LOS	B

Notes

User approved volume balancing among the lanes for turning movement.  
 Unsignalized Delay for [SBR] is excluded from calculations of the approach delay and intersection delay.

HCM 6th Signalized Intersection Summary

Existing Project Alter. B Conditions

12: US 101 SB On Ramp/US 101 SB Off Ramp & Old Redwood Highway

Timing Plan: A.M. PEAK



Movement	EBL	EBT	EBR	WBL	WBT	WBR	NBL	NBT	NBR	SBL	SBT	SBR
Lane Configurations		↑↑	↗	↘	↑↑					↘	↕	
Traffic Volume (veh/h)	0	298	296	513	504	0	0	0	0	120	1	65
Future Volume (veh/h)	0	298	296	513	504	0	0	0	0	120	1	65
Initial Q (Qb), veh	0	0	0	0	0	0				0	0	0
Ped-Bike Adj(A_pbT)	1.00		0.98	1.00		1.00				1.00		1.00
Parking Bus, Adj	1.00	1.00	1.00	1.00	1.00	1.00				1.00	1.00	1.00
Work Zone On Approach		No			No						No	
Adj Sat Flow, veh/h/ln	0	1870	1870	1870	1870	0				1870	1870	1870
Adj Flow Rate, veh/h	0	324	322	576	566	0				114	48	0
Peak Hour Factor	0.92	0.92	0.92	0.89	0.89	0.89				0.81	0.81	0.81
Percent Heavy Veh, %	0	2	2	2	2	0				2	2	2
Cap, veh/h	0	1281	563	613	2683	0				217	228	
Arrive On Green	0.00	0.36	0.36	0.34	0.76	0.00				0.12	0.12	0.00
Sat Flow, veh/h	0	3647	1560	1781	3647	0				1781	1870	0
Grp Volume(v), veh/h	0	324	322	576	566	0				114	48	0
Grp Sat Flow(s),veh/h/ln	0	1777	1560	1781	1777	0				1781	1870	0
Q Serve(g_s), s	0.0	5.1	13.3	25.0	3.7	0.0				4.8	1.8	0.0
Cycle Q Clear(g_c), s	0.0	5.1	13.3	25.0	3.7	0.0				4.8	1.8	0.0
Prop In Lane	0.00		1.00	1.00		0.00				1.00		0.00
Lane Grp Cap(c), veh/h	0	1281	563	613	2683	0				217	228	
V/C Ratio(X)	0.00	0.25	0.57	0.94	0.21	0.00				0.52	0.21	
Avail Cap(c_a), veh/h	0	1281	563	648	2683	0				223	235	
HCM Platoon Ratio	1.00	1.00	1.00	1.00	1.00	1.00				1.00	1.00	1.00
Upstream Filter(I)	0.00	1.00	1.00	1.00	1.00	0.00				1.00	1.00	0.00
Uniform Delay (d), s/veh	0.0	17.9	20.5	25.3	2.8	0.0				32.8	31.5	0.0
Incr Delay (d2), s/veh	0.0	0.5	4.2	21.1	0.2	0.0				2.1	0.5	0.0
Initial Q Delay(d3),s/veh	0.0	0.0	0.0	0.0	0.0	0.0				0.0	0.0	0.0
%ile BackOfQ(50%),veh/ln	0.0	2.1	5.1	13.3	0.8	0.0				2.1	0.8	0.0
Unsig. Movement Delay, s/veh												
LnGrp Delay(d),s/veh	0.0	18.4	24.7	46.4	3.0	0.0				34.9	32.0	0.0
LnGrp LOS	A	B	C	D	A	A				C	C	
Approach Vol, veh/h		646			1142							162
Approach Delay, s/veh		21.6			24.9							34.1
Approach LOS		C			C							C
Timer - Assigned Phs		2			5	6			8			
Phs Duration (G+Y+Rc), s		65.3			31.5	33.8			14.4			
Change Period (Y+Rc), s		5.1			4.0	5.1			4.7			
Max Green Setting (Gmax), s		60.2			29.0	27.2			10.0			
Max Q Clear Time (g_c+I1), s		5.7			27.0	15.3			6.8			
Green Ext Time (p_c), s		4.2			0.5	2.6			0.1			

Intersection Summary























HCM 6th Ctrl Delay	24.6
HCM 6th LOS	C

Notes

- User approved volume balancing among the lanes for turning movement.
- User approved ignoring U-Turning movement.
- Unsignalized Delay for [SBR] is excluded from calculations of the approach delay and intersection delay.

HCM 6th Signalized Intersection Summary  
 1: Old Redwood Hwy & Shiloh Road

Existing Project Alter. B Conditions  
 Timing Plan: P.M. Peak

												
Movement	EBL	EBT	EBR	WBL	WBT	WBR	NBL	NBT	NBR	SBL	SBT	SBR
Lane Configurations												
Traffic Volume (veh/h)	241	356	223	37	332	49	198	345	21	59	242	146
Future Volume (veh/h)	241	356	223	37	332	49	198	345	21	59	242	146
Initial Q (Qb), veh	0	0	0	0	0	0	0	0	0	0	0	0
Ped-Bike Adj(A_pbT)	1.00		1.00	1.00		1.00	1.00		0.97	1.00		0.97
Parking Bus, Adj	1.00	1.00	1.00	1.00	1.00	1.00	1.00	1.00	1.00	1.00	1.00	1.00
Work Zone On Approach		No			No			No			No	
Adj Sat Flow, veh/h/ln	1870	1870	1870	1870	1870	1870	1870	1870	1870	1870	1870	1870
Adj Flow Rate, veh/h	248	367	230	41	365	54	213	371	23	63	260	157
Peak Hour Factor	0.97	0.97	0.97	0.91	0.91	0.91	0.93	0.93	0.93	0.93	0.93	0.93
Percent Heavy Veh, %	2	2	2	2	2	2	2	2	2	2	2	2
Cap, veh/h	427	449	379	48	428	405	249	492	406	100	336	277
Arrive On Green	0.24	0.24	0.24	0.26	0.26	0.26	0.14	0.26	0.26	0.06	0.18	0.18
Sat Flow, veh/h	1781	1870	1582	188	1673	1582	1781	1870	1544	1781	1870	1539
Grp Volume(v), veh/h	248	367	230	406	0	54	213	371	23	63	260	157
Grp Sat Flow(s),veh/h/ln	1781	1870	1582	1861	0	1582	1781	1870	1544	1781	1870	1539
Q Serve(g_s), s	11.3	17.1	11.9	19.1	0.0	2.4	10.8	16.8	1.0	3.2	12.2	8.6
Cycle Q Clear(g_c), s	11.3	17.1	11.9	19.1	0.0	2.4	10.8	16.8	1.0	3.2	12.2	8.6
Prop In Lane	1.00		1.00	0.10		1.00	1.00		1.00	1.00		1.00
Lane Grp Cap(c), veh/h	427	449	379	477	0	405	249	492	406	100	336	277
V/C Ratio(X)	0.58	0.82	0.61	0.85	0.00	0.13	0.86	0.75	0.06	0.63	0.77	0.57
Avail Cap(c_a), veh/h	590	620	524	768	0	653	281	884	730	116	711	585
HCM Platoon Ratio	1.00	1.00	1.00	1.00	1.00	1.00	1.00	1.00	1.00	1.00	1.00	1.00
Upstream Filter(I)	1.00	1.00	1.00	1.00	0.00	1.00	1.00	1.00	1.00	1.00	1.00	1.00
Uniform Delay (d), s/veh	30.9	33.1	31.1	32.6	0.0	26.4	38.7	31.2	25.4	42.5	36.0	34.5
Incr Delay (d2), s/veh	1.3	6.1	1.6	5.3	0.0	0.1	20.4	2.4	0.1	8.1	3.8	1.8
Initial Q Delay(d3),s/veh	0.0	0.0	0.0	0.0	0.0	0.0	0.0	0.0	0.0	0.0	0.0	0.0
%ile BackOfQ(50%),veh/ln	4.8	8.1	4.4	8.8	0.0	0.9	5.9	7.4	0.4	1.6	5.7	3.2
Unsig. Movement Delay, s/veh												
LnGrp Delay(d),s/veh	32.1	39.1	32.7	37.8	0.0	26.5	59.1	33.6	25.4	50.6	39.8	36.3
LnGrp LOS	C	D	C	D	A	C	E	C	C	D	D	D
Approach Vol, veh/h		845			460			607			480	
Approach Delay, s/veh		35.3			36.5			42.2			40.1	
Approach LOS		D			D			D			D	
Timer - Assigned Phs		2	3	4		6	7	8				
Phs Duration (G+Y+Rc), s		26.6	16.4	21.0		28.1	8.7	28.7				
Change Period (Y+Rc), s		4.5	3.5	4.5		4.5	3.5	4.5				
Max Green Setting (Gmax), s		30.5	14.5	35.0		38.0	6.0	43.5				
Max Q Clear Time (g_c+I1), s		19.1	12.8	14.2		21.1	5.2	18.8				
Green Ext Time (p_c), s		2.9	0.1	1.9		2.3	0.0	2.1				
<b>Intersection Summary</b>												
HCM 6th Ctrl Delay			38.2									
HCM 6th LOS			D									



HCM Signalized Intersection Capacity Analysis  
 2: Shiloh Road & Hembree Ln

Existing Project Alter. B Conditions  
 Timing Plan: P.M. Peak



Movement	EBL	EBT	WBT	WBR	SBL	SBR
Lane Configurations	↔↔	↑	↕↔		↔	↔
Traffic Volume (vph)	615	669	560	141	170	491
Future Volume (vph)	615	669	560	141	170	491
Ideal Flow (vphpl)	1900	1900	1900	1900	1900	1900
Total Lost time (s)	4.0	4.0	4.0		4.0	4.0
Lane Util. Factor	0.97	1.00	0.95		1.00	1.00
Frbp, ped/bikes	1.00	1.00	1.00		1.00	1.00
Flpb, ped/bikes	1.00	1.00	1.00		1.00	1.00
Frt	1.00	1.00	0.97		1.00	0.85
Flt Protected	0.95	1.00	1.00		0.95	1.00
Satd. Flow (prot)	3433	1863	3424		1770	1583
Flt Permitted	0.95	1.00	1.00		0.95	1.00
Satd. Flow (perm)	3433	1863	3424		1770	1583
Peak-hour factor, PHF	0.94	0.94	0.87	0.87	0.95	0.95
Adj. Flow (vph)	654	712	644	162	179	517
RTOR Reduction (vph)	0	0	30	0	0	85
Lane Group Flow (vph)	654	712	776	0	179	432
Confl. Peds. (#/hr)	2			2		
Turn Type	Prot	NA	NA		Perm	pm+ov
Protected Phases	5	2	6			5
Permitted Phases					4	4 5
Actuated Green, G (s)	18.9	45.1	22.2		11.4	30.3
Effective Green, g (s)	18.9	45.1	22.2		11.4	30.3
Actuated g/C Ratio	0.29	0.70	0.34		0.18	0.47
Clearance Time (s)	4.0	4.0	4.0		4.0	4.0
Vehicle Extension (s)	3.0	3.0	3.0		3.0	3.0
Lane Grp Cap (vph)	1005	1302	1178		312	841
v/s Ratio Prot	c0.19	0.38	c0.23			c0.15
v/s Ratio Perm					0.10	0.12
v/c Ratio	0.65	0.55	0.66		0.57	0.51
Uniform Delay, d1	19.9	4.7	17.9		24.3	12.0
Progression Factor	1.00	1.00	1.00		1.00	1.00
Incremental Delay, d2	1.5	0.5	1.3		2.5	0.5
Delay (s)	21.4	5.2	19.3		26.9	12.5
Level of Service	C	A	B		C	B
Approach Delay (s)		13.0	19.3		16.2	
Approach LOS		B	B		B	
<b>Intersection Summary</b>						
HCM 2000 Control Delay			15.5		HCM 2000 Level of Service	B
HCM 2000 Volume to Capacity ratio			0.64			
Actuated Cycle Length (s)			64.5		Sum of lost time (s)	12.0
Intersection Capacity Utilization			57.9%		ICU Level of Service	B
Analysis Period (min)			15			
c Critical Lane Group						

HCM 6th Signalized Intersection Summary  
 3: US 101 NB Off-Ramp & Shiloh Road

Existing Project Alter. B Conditions  
 Timing Plan: P.M. Peak



Movement	EBT	EBR	WBL	WBT	NBL	NBR
Lane Configurations	↑↑			↑	↘	↗
Traffic Volume (veh/h)	482	0	0	722	526	807
Future Volume (veh/h)	482	0	0	722	526	807
Initial Q (Qb), veh	0	0	0	0	0	0
Ped-Bike Adj(A_pbT)		1.00	1.00		1.00	1.00
Parking Bus, Adj	1.00	1.00	1.00	1.00	1.00	1.00
Work Zone On Approach	No			No	No	
Adj Sat Flow, veh/h/ln	1870	0	0	1870	1870	1870
Adj Flow Rate, veh/h	513	0	0	744	584	897
Peak Hour Factor	0.94	0.94	0.97	0.97	0.90	0.90
Percent Heavy Veh, %	2	0	0	2	2	2
Cap, veh/h	1613	0	0	849	730	1143
Arrive On Green	0.45	0.00	0.00	0.45	0.41	0.41
Sat Flow, veh/h	3741	0	0	1870	1781	2790
Grp Volume(v), veh/h	513	0	0	744	584	897
Grp Sat Flow(s),veh/h/ln	1777	0	0	1870	1781	1395
Q Serve(g_s), s	5.4	0.0	0.0	21.1	16.9	16.4
Cycle Q Clear(g_c), s	5.4	0.0	0.0	21.1	16.9	16.4
Prop In Lane		0.00	0.00		1.00	1.00
Lane Grp Cap(c), veh/h	1613	0	0	849	730	1143
V/C Ratio(X)	0.32	0.00	0.00	0.88	0.80	0.79
Avail Cap(c_a), veh/h	2003	0	0	1054	943	1477
HCM Platoon Ratio	1.00	1.00	1.00	1.00	1.00	1.00
Upstream Filter(I)	1.00	0.00	0.00	1.00	1.00	1.00
Uniform Delay (d), s/veh	10.2	0.0	0.0	14.5	15.2	15.0
Incr Delay (d2), s/veh	0.1	0.0	0.0	7.2	3.8	2.2
Initial Q Delay(d3),s/veh	0.0	0.0	0.0	0.0	0.0	0.0
%ile BackOfQ(50%),veh/ln	1.7	0.0	0.0	8.5	6.6	4.8
Unsig. Movement Delay, s/veh						
LnGrp Delay(d),s/veh	10.3	0.0	0.0	21.7	19.0	17.2
LnGrp LOS	B	A	A	C	B	B
Approach Vol, veh/h	513			744	1481	
Approach Delay, s/veh	10.3			21.7	17.9	
Approach LOS	B			C	B	
Timer - Assigned Phs		2			6	8
Phs Duration (G+Y+Rc), s		30.6			30.6	28.0
Change Period (Y+Rc), s		4.0			4.0	4.0
Max Green Setting (Gmax), s		33.0			33.0	31.0
Max Q Clear Time (g_c+I1), s		7.4			23.1	18.9
Green Ext Time (p_c), s		3.3			3.4	5.1
<b>Intersection Summary</b>						
HCM 6th Ctrl Delay			17.5			
HCM 6th LOS			B			

HCM Signalized Intersection Capacity Analysis  
4: Shiloh Road & US 101 SB Off-Ramp

Existing Project Alter. B Conditions  
Timing Plan: P.M. Peak



Movement	EBL	EBT	WBT	WBR	SBL	SBR
Lane Configurations		↑	↑		↘	↘
Traffic Volume (vph)	0	445	636	0	233	110
Future Volume (vph)	0	445	636	0	233	110
Ideal Flow (vphpl)	1900	1900	1900	1900	1900	1900
Total Lost time (s)		4.0	4.0		4.0	4.0
Lane Util. Factor		1.00	1.00		1.00	1.00
Frbp, ped/bikes		1.00	1.00		1.00	0.98
Flpb, ped/bikes		1.00	1.00		1.00	1.00
Frt		1.00	1.00		1.00	0.85
Flt Protected		1.00	1.00		0.95	1.00
Satd. Flow (prot)		1863	1863		1770	1549
Flt Permitted		1.00	1.00		0.95	1.00
Satd. Flow (perm)		1863	1863		1770	1549
Peak-hour factor, PHF	0.89	0.89	0.96	0.96	0.93	0.93
Adj. Flow (vph)	0	500	662	0	251	118
RTOR Reduction (vph)	0	0	0	0	0	84
Lane Group Flow (vph)	0	500	663	0	251	34
Confl. Peds. (#/hr)						1
Turn Type		NA	NA		Perm	Perm
Protected Phases		2	6			
Permitted Phases					4	4
Actuated Green, G (s)		21.6	21.6		11.9	11.9
Effective Green, g (s)		21.6	21.6		11.9	11.9
Actuated g/C Ratio		0.52	0.52		0.29	0.29
Clearance Time (s)		4.0	4.0		4.0	4.0
Vehicle Extension (s)		3.0	3.0		3.0	3.0
Lane Grp Cap (vph)		969	969		507	444
v/s Ratio Prot		0.27	c0.36			
v/s Ratio Perm					c0.14	0.02
v/c Ratio		0.52	0.68		0.50	0.08
Uniform Delay, d1		6.5	7.4		12.3	10.8
Progression Factor		1.00	1.00		1.00	1.00
Incremental Delay, d2		0.5	2.0		0.8	0.1
Delay (s)		7.0	9.4		13.1	10.9
Level of Service		A	A		B	B
Approach Delay (s)		7.0	9.4		12.4	
Approach LOS		A	A		B	
<b>Intersection Summary</b>						
HCM 2000 Control Delay			9.3		HCM 2000 Level of Service	A
HCM 2000 Volume to Capacity ratio			0.62			
Actuated Cycle Length (s)			41.5		Sum of lost time (s)	8.0
Intersection Capacity Utilization			113.7%		ICU Level of Service	H
Analysis Period (min)			15			
c Critical Lane Group						

Intersection						
Int Delay, s/veh	2.5					
Movement	EBT	EBR	WBL	WBT	NBL	NBR
Lane Configurations	↑↑		↘	↑	↘	↘
Traffic Vol, veh/h	873	28	79	672	15	149
Future Vol, veh/h	873	28	79	672	15	149
Conflicting Peds, #/hr	0	0	0	0	0	0
Sign Control	Free	Free	Free	Free	Stop	Stop
RT Channelized	-	None	-	None	-	None
Storage Length	-	-	68	-	0	0
Veh in Median Storage, #	0	-	-	0	0	-
Grade, %	0	-	-	0	0	-
Peak Hour Factor	89	89	92	92	89	89
Heavy Vehicles, %	2	2	2	2	2	2
Mvmt Flow	981	31	86	730	17	167

Major/Minor	Major1	Major2	Minor1	Minor2	Minor3
Conflicting Flow All	0	0	1012	0	1899
Stage 1	-	-	-	-	997
Stage 2	-	-	-	-	902
Critical Hdwy	-	-	4.13	-	6.63
Critical Hdwy Stg 1	-	-	-	-	5.83
Critical Hdwy Stg 2	-	-	-	-	5.43
Follow-up Hdwy	-	-	2.219	-	3.519
Pot Cap-1 Maneuver	-	-	683	-	68
Stage 1	-	-	-	-	319
Stage 2	-	-	-	-	395
Platoon blocked, %	-	-	-	-	-
Mov Cap-1 Maneuver	-	-	683	-	59
Mov Cap-2 Maneuver	-	-	-	-	59
Stage 1	-	-	-	-	319
Stage 2	-	-	-	-	345

Approach	EB	WB	NB
HCM Control Delay, s	0	1.2	22.1
HCM LOS			C

Minor Lane/Major Mvmt	NBLn1	NBLn2	EBT	EBR	WBL	WBT
Capacity (veh/h)	59	512	-	-	683	-
HCM Lane V/C Ratio	0.286	0.327	-	-	0.126	-
HCM Control Delay (s)	88.8	15.4	-	-	11	-
HCM Lane LOS	F	C	-	-	B	-
HCM 95th %tile Q(veh)	1	1.4	-	-	0.4	-

HCM Signalized Intersection Capacity Analysis  
6: Conde Lane & Shiloh Road

Existing Project Alter. B Conditions  
Timing Plan: P.M. Peak

Movement	EBL	EBT	EBR	WBL	WBT	WBR	NBL	NBT	NBR	SBL	SBT	SBR
Lane Configurations												
Traffic Volume (vph)	69	492	2	7	477	289	5	3	17	297	0	39
Future Volume (vph)	69	492	2	7	477	289	5	3	17	297	0	39
Ideal Flow (vphpl)	1900	1900	1900	1900	1900	1900	1900	1900	1900	1900	1900	1900
Total Lost time (s)	4.0	4.0		4.0	4.0			4.0			4.0	4.0
Lane Util. Factor	1.00	0.95		1.00	0.95			1.00			1.00	1.00
Frbp, ped/bikes	1.00	1.00		1.00	0.99			1.00			1.00	1.00
Flpb, ped/bikes	1.00	1.00		1.00	1.00			1.00			1.00	1.00
Frt	1.00	1.00		1.00	0.94			0.91			1.00	0.85
Flt Protected	0.95	1.00		0.95	1.00			0.99			0.95	1.00
Satd. Flow (prot)	1770	3537		1770	3312			1676			1770	1583
Flt Permitted	0.95	1.00		0.95	1.00			0.99			0.95	1.00
Satd. Flow (perm)	1770	3537		1770	3312			1676			1770	1583
Peak-hour factor, PHF	0.88	0.88	0.88	0.80	0.80	0.80	0.63	0.63	0.63	0.88	0.88	0.88
Adj. Flow (vph)	78	559	2	9	596	361	8	5	27	338	0	44
RTOR Reduction (vph)	0	0	0	0	79	0	0	25	0	0	0	0
Lane Group Flow (vph)	78	561	0	9	878	0	0	15	0	0	338	44
Confl. Peds. (#/hr)	1					1						
Turn Type	Prot	NA		Prot	NA		Split	NA		Split	NA	custom
Protected Phases	5	2		1	6		7	7		4	4	
Permitted Phases												6
Actuated Green, G (s)	6.4	31.6		1.2	26.4			4.9			12.4	26.4
Effective Green, g (s)	6.4	31.6		1.2	26.4			4.9			12.4	26.4
Actuated g/C Ratio	0.10	0.48		0.02	0.40			0.07			0.19	0.40
Clearance Time (s)	4.0	4.0		4.0	4.0			4.0			4.0	4.0
Vehicle Extension (s)	3.0	3.0		3.0	3.0			3.0			3.0	3.0
Lane Grp Cap (vph)	171	1690		32	1322			124			332	632
v/s Ratio Prot	c0.04	0.16		0.01	c0.26			c0.01			c0.19	
v/s Ratio Perm												0.03
v/c Ratio	0.46	0.33		0.28	0.66			0.12			1.02	0.07
Uniform Delay, d1	28.2	10.7		32.0	16.2			28.6			26.8	12.3
Progression Factor	1.00	1.00		1.00	1.00			1.00			1.00	1.00
Incremental Delay, d2	1.9	0.1		4.8	1.3			0.4			54.1	0.0
Delay (s)	30.1	10.8		36.8	17.5			29.0			80.9	12.3
Level of Service	C	B		D	B			C			F	B
Approach Delay (s)		13.2			17.7			29.0			73.0	
Approach LOS		B			B			C			E	
<b>Intersection Summary</b>												
HCM 2000 Control Delay			26.9									HCM 2000 Level of Service C
HCM 2000 Volume to Capacity ratio			0.67									
Actuated Cycle Length (s)			66.1						16.0			
Intersection Capacity Utilization			62.3%									ICU Level of Service B
Analysis Period (min)			15									
c Critical Lane Group												

HCM 6th TWSC  
7: Driveway 1/Gridley Drive & Shiloh Road

Existing Project Alter. B Conditions  
Timing Plan: P.M. Peak

Intersection												
Int Delay, s/veh	2.1											
Movement	EBL	EBT	EBR	WBL	WBT	WBR	NBL	NBT	NBR	SBL	SBT	SBR
Lane Configurations		↔	↔		↔		↔	↔			↔	
Traffic Vol, veh/h	17	336	76	0	341	0	71	0	0	0	0	14
Future Vol, veh/h	17	336	76	0	341	0	71	0	0	0	0	14
Conflicting Peds, #/hr	1	0	0	0	0	0	0	0	0	0	0	0
Sign Control	Free	Free	Free	Free	Free	Free	Stop	Stop	Stop	Stop	Stop	Stop
RT Channelized	-	-	None	-	-	None	-	-	None	-	-	None
Storage Length	-	-	150	-	-	-	0	-	-	-	-	-
Veh in Median Storage, #	-	0	-	-	0	-	-	0	-	-	0	-
Grade, %	-	0	-	-	0	-	-	0	-	-	0	-
Peak Hour Factor	94	94	94	69	69	69	100	100	100	58	58	58
Heavy Vehicles, %	2	2	2	2	2	2	2	2	2	2	2	2
Mvmt Flow	18	357	81	0	494	0	71	0	0	0	0	24

Major/Minor	Major1			Major2			Minor1			Minor2		
Conflicting Flow All	495	0	0	438	0	0	899	888	357	929	969	495
Stage 1	-	-	-	-	-	-	393	393	-	495	495	-
Stage 2	-	-	-	-	-	-	506	495	-	434	474	-
Critical Hdwy	4.12	-	-	4.12	-	-	7.12	6.52	6.22	7.12	6.52	6.22
Critical Hdwy Stg 1	-	-	-	-	-	-	6.12	5.52	-	6.12	5.52	-
Critical Hdwy Stg 2	-	-	-	-	-	-	6.12	5.52	-	6.12	5.52	-
Follow-up Hdwy	2.218	-	-	2.218	-	-	3.518	4.018	3.318	3.518	4.018	3.318
Pot Cap-1 Maneuver	1069	-	-	1122	-	-	260	283	687	248	254	575
Stage 1	-	-	-	-	-	-	632	606	-	556	546	-
Stage 2	-	-	-	-	-	-	549	546	-	600	558	-
Platoon blocked, %		-	-		-	-						
Mov Cap-1 Maneuver	1068	-	-	1122	-	-	245	276	687	244	248	574
Mov Cap-2 Maneuver	-	-	-	-	-	-	245	276	-	244	248	-
Stage 1	-	-	-	-	-	-	617	592	-	543	545	-
Stage 2	-	-	-	-	-	-	526	545	-	586	545	-

Approach	EB	WB	NB	SB
HCM Control Delay, s	0.3	0	25.6	11.5
HCM LOS			D	B

Minor Lane/Major Mvmt	NBLn1	NBLn2	EBL	EBT	EBR	WBL	WBT	WBR	SBLn1
Capacity (veh/h)	245	-	1068	-	-	1122	-	-	574
HCM Lane V/C Ratio	0.29	-	0.017	-	-	-	-	-	0.042
HCM Control Delay (s)	25.6	0	8.4	0	-	0	-	-	11.5
HCM Lane LOS	D	A	A	A	-	A	-	-	B
HCM 95th %tile Q(veh)	1.2	-	0.1	-	-	0	-	-	0.1

HCM 6th TWSC  
8: Old Redwood Hwy & Driveway 2

Existing Project Alter. B Conditions  
Timing Plan: P.M. Peak

Intersection												
Int Delay, s/veh	2.6											
Movement	EBL	EBT	EBR	WBL	WBT	WBR	NBL	NBT	NBR	SBL	SBT	SBR
Lane Configurations		↕		↕	↕			↕	↕	↕	↕	
Traffic Vol, veh/h	3	0	0	41	0	66	0	505	45	72	427	0
Future Vol, veh/h	3	0	0	41	0	66	0	505	45	72	427	0
Conflicting Peds, #/hr	0	0	0	0	0	0	0	0	0	0	0	0
Sign Control	Stop	Stop	Stop	Stop	Stop	Stop	Free	Free	Free	Free	Free	Free
RT Channelized	-	-	None	-	-	None	-	-	None	-	-	None
Storage Length	-	-	-	0	-	-	-	-	100	50	-	-
Veh in Median Storage, #	-	0	-	-	0	-	-	0	-	-	0	-
Grade, %	-	0	-	-	0	-	-	0	-	-	0	-
Peak Hour Factor	38	38	38	100	100	100	91	91	91	94	94	94
Heavy Vehicles, %	2	2	2	2	2	2	2	2	2	2	2	2
Mvmt Flow	8	0	0	41	0	66	0	555	49	77	454	0

Major/Minor	Minor2		Minor1		Major1		Major2					
Conflicting Flow All	1221	1212	454	1163	1163	555	454	0	0	604	0	0
Stage 1	608	608	-	555	555	-	-	-	-	-	-	-
Stage 2	613	604	-	608	608	-	-	-	-	-	-	-
Critical Hdwy	7.12	6.52	6.22	7.12	6.52	6.22	4.12	-	-	4.12	-	-
Critical Hdwy Stg 1	6.12	5.52	-	6.12	5.52	-	-	-	-	-	-	-
Critical Hdwy Stg 2	6.12	5.52	-	6.12	5.52	-	-	-	-	-	-	-
Follow-up Hdwy	3.518	4.018	3.318	3.518	4.018	3.318	2.218	-	-	2.218	-	-
Pot Cap-1 Maneuver	157	182	606	172	195	531	1107	-	-	974	-	-
Stage 1	483	486	-	516	513	-	-	-	-	-	-	-
Stage 2	480	488	-	483	486	-	-	-	-	-	-	-
Platoon blocked, %								-	-	-	-	-
Mov Cap-1 Maneuver	129	168	606	162	180	531	1107	-	-	974	-	-
Mov Cap-2 Maneuver	129	168	-	162	180	-	-	-	-	-	-	-
Stage 1	483	448	-	516	513	-	-	-	-	-	-	-
Stage 2	420	488	-	445	448	-	-	-	-	-	-	-

Approach	EB		WB		NB		SB	
HCM Control Delay, s	34.7		21.1		0		1.3	
HCM LOS	D		C					

Minor Lane/Major Mvmt	NBL	NBT	NBR	EBLn1	WBLn1	WBLn2	SBL	SBT	SBR
Capacity (veh/h)	1107	-	-	129	162	531	974	-	-
HCM Lane V/C Ratio	-	-	-	0.061	0.253	0.124	0.079	-	-
HCM Control Delay (s)	0	-	-	34.7	34.6	12.7	9	-	-
HCM Lane LOS	A	-	-	D	D	B	A	-	-
HCM 95th %tile Q(veh)	0	-	-	0.2	1	0.4	0.3	-	-

Intersection						
Int Delay, s/veh	4.2					
Movement	EBT	EBR	WBL	WBT	NBL	NBR
Lane Configurations	↑	↗		↖	↖	↗
Traffic Vol, veh/h	81	233	22	111	216	21
Future Vol, veh/h	81	233	22	111	216	21
Conflicting Peds, #/hr	0	0	0	0	0	0
Sign Control	Free	Free	Free	Free	Stop	Stop
RT Channelized	-	None	-	None	-	None
Storage Length	-	200	-	-	0	0
Veh in Median Storage, #	0	-	-	0	0	-
Grade, %	0	-	-	0	0	-
Peak Hour Factor	92	92	68	68	100	100
Heavy Vehicles, %	2	2	2	2	2	2
Mvmt Flow	88	253	32	163	216	21

Major/Minor	Major1	Major2	Minor1			
Conflicting Flow All	0	0	341	0	315	88
Stage 1	-	-	-	-	88	-
Stage 2	-	-	-	-	227	-
Critical Hdwy	-	-	4.12	-	6.42	6.22
Critical Hdwy Stg 1	-	-	-	-	5.42	-
Critical Hdwy Stg 2	-	-	-	-	5.42	-
Follow-up Hdwy	-	-	2.218	-	3.518	3.318
Pot Cap-1 Maneuver	-	-	1218	-	678	970
Stage 1	-	-	-	-	935	-
Stage 2	-	-	-	-	811	-
Platoon blocked, %	-	-	-	-	-	-
Mov Cap-1 Maneuver	-	-	1218	-	658	970
Mov Cap-2 Maneuver	-	-	-	-	658	-
Stage 1	-	-	-	-	935	-
Stage 2	-	-	-	-	787	-

Approach	EB	WB	NB
HCM Control Delay, s	0	1.3	12.7
HCM LOS			B

Minor Lane/Major Mvmt	NBLn1	NBLn2	EBT	EBR	WBL	WBT
Capacity (veh/h)	658	970	-	-	1218	-
HCM Lane V/C Ratio	0.328	0.022	-	-	0.027	-
HCM Control Delay (s)	13.1	8.8	-	-	8	0
HCM Lane LOS	B	A	-	-	A	A
HCM 95th %tile Q(veh)	1.4	0.1	-	-	0.1	-



HCM 6th Signalized Intersection Summary

Existing Project Alter. B Conditions

10: US 101 NB Off Ramp/Lakewood Drive & Old Redwood Highway

Timing Plan: P.M. Peak



Movement	EBL	EBT	EBR	WBL	WBT	WBR	NBL	NBT	NBR	SBL	SBT	SBR
Lane Configurations												
Traffic Volume (veh/h)	261	395	0	0	538	192	500	412	251	249	0	577
Future Volume (veh/h)	261	395	0	0	538	192	500	412	251	249	0	577
Initial Q (Qb), veh	0	0	0	0	0	0	0	0	0	0	0	0
Ped-Bike Adj(A_pbT)	1.00		1.00	1.00		0.98	1.00		0.99	1.00		1.00
Parking Bus, Adj	1.00	1.00	1.00	1.00	1.00	1.00	1.00	1.00	1.00	1.00	1.00	1.00
Work Zone On Approach		No			No			No			No	
Adj Sat Flow, veh/h/ln	1870	1870	0	0	1870	1870	1870	1870	1870	1870	0	1870
Adj Flow Rate, veh/h	300	454	0	0	591	211	421	618	273	259	0	0
Peak Hour Factor	0.87	0.87	0.87	0.91	0.91	0.91	0.92	0.92	0.92	0.96	0.96	0.96
Percent Heavy Veh, %	2	2	0	0	2	2	2	2	2	2	0	2
Cap, veh/h	388	1010	0	0	955	340	584	805	355	0	0	0
Arrive On Green	0.11	0.54	0.00	0.00	0.37	0.37	0.33	0.33	0.33	0.00	0.00	0.00
Sat Flow, veh/h	3456	1870	0	0	2646	909	1781	2453	1083		0	
Grp Volume(v), veh/h	300	454	0	0	411	391	421	471	420		0.0	
Grp Sat Flow(s),veh/h/ln	1728	1870	0	0	1777	1685	1781	1870	1666			
Q Serve(g_s), s	6.3	11.0	0.0	0.0	14.0	14.1	15.5	16.8	16.9			
Cycle Q Clear(g_c), s	6.3	11.0	0.0	0.0	14.0	14.1	15.5	16.8	16.9			
Prop In Lane	1.00		0.00	0.00		0.54	1.00		0.65			
Lane Grp Cap(c), veh/h	388	1010	0	0	665	631	584	614	547			
V/C Ratio(X)	0.77	0.45	0.00	0.00	0.62	0.62	0.72	0.77	0.77			
Avail Cap(c_a), veh/h	418	1010	0	0	665	631	694	729	649			
HCM Platoon Ratio	1.00	1.00	1.00	1.00	1.00	1.00	1.00	1.00	1.00			
Upstream Filter(I)	1.00	1.00	0.00	0.00	1.00	1.00	1.00	1.00	1.00			
Uniform Delay (d), s/veh	32.1	10.4	0.0	0.0	19.0	19.0	22.0	22.5	22.5			
Incr Delay (d2), s/veh	8.2	1.4	0.0	0.0	4.3	4.5	3.0	4.2	4.7			
Initial Q Delay(d3),s/veh	0.0	0.0	0.0	0.0	0.0	0.0	0.0	0.0	0.0			
%ile BackOfQ(50%),veh/ln	2.9	4.3	0.0	0.0	6.0	5.8	6.5	7.6	6.9			
Unsig. Movement Delay, s/veh												
LnGrp Delay(d),s/veh	40.3	11.8	0.0	0.0	23.2	23.5	25.0	26.6	27.1			
LnGrp LOS	D	B	A	A	C	C	C	C	C			
Approach Vol, veh/h		754			802			1312				
Approach Delay, s/veh		23.2			23.4			26.2				
Approach LOS		C			C			C				
Timer - Assigned Phs		2			5	6		8				
Phs Duration (G+Y+Rc), s		45.3			12.3	33.0		29.1				
Change Period (Y+Rc), s		5.1			4.0	5.1		4.7				
Max Green Setting (Gmax), s		40.2			9.0	27.2		29.0				
Max Q Clear Time (g_c+I1), s		13.0			8.3	16.1		18.9				
Green Ext Time (p_c), s		2.9			0.1	3.8		5.2				

Intersection Summary

HCM 6th Ctrl Delay	24.6
HCM 6th LOS	C

Notes

User approved volume balancing among the lanes for turning movement.  
 Unsignalized Delay for [SBR] is excluded from calculations of the approach delay and intersection delay.

HCM 6th Signalized Intersection Summary

Existing Project Alter. B Conditions

12: US 101 SB On Ramp/US 101 SB Off Ramp & Old Redwood Highway

Timing Plan: P.M. Peak



Movement	EBL	EBT	EBR	WBL	WBT	WBR	NBL	NBT	NBR	SBL	SBT	SBR
Lane Configurations		↑↑	↗	↘	↑↑					↖	↕	
Traffic Volume (veh/h)	0	535	381	381	1024	0	0	0	0	212	0	129
Future Volume (veh/h)	0	535	381	381	1024	0	0	0	0	212	0	129
Initial Q (Qb), veh	0	0	0	0	0	0				0	0	0
Ped-Bike Adj(A_pbT)	1.00		0.98	1.00		1.00				1.00		1.00
Parking Bus, Adj	1.00	1.00	1.00	1.00	1.00	1.00				1.00	1.00	1.00
Work Zone On Approach		No			No						No	
Adj Sat Flow, veh/h/ln	0	1870	1870	1870	1870	0				1870	1870	1870
Adj Flow Rate, veh/h	0	569	405	428	1151	0				205	70	0
Peak Hour Factor	0.94	0.94	0.94	0.89	0.89	0.89				0.83	0.83	0.83
Percent Heavy Veh, %	0	2	2	2	2	0				2	2	2
Cap, veh/h	0	1423	625	460	2546	0				254	267	
Arrive On Green	0.00	0.40	0.40	0.26	0.72	0.00				0.14	0.14	0.00
Sat Flow, veh/h	0	3647	1560	1781	3647	0				1781	1870	0
Grp Volume(v), veh/h	0	569	405	428	1151	0				205	70	0
Grp Sat Flow(s),veh/h/ln	0	1777	1560	1781	1777	0				1781	1870	0
Q Serve(g_s), s	0.0	8.0	14.6	16.3	9.5	0.0				7.8	2.3	0.0
Cycle Q Clear(g_c), s	0.0	8.0	14.6	16.3	9.5	0.0				7.8	2.3	0.0
Prop In Lane	0.00		1.00	1.00		0.00				1.00		0.00
Lane Grp Cap(c), veh/h	0	1423	625	460	2546	0				254	267	
V/C Ratio(X)	0.00	0.40	0.65	0.93	0.45	0.00				0.81	0.26	
Avail Cap(c_a), veh/h	0	1423	625	460	2546	0				263	277	
HCM Platoon Ratio	1.00	1.00	1.00	1.00	1.00	1.00				1.00	1.00	1.00
Upstream Filter(I)	0.00	1.00	1.00	1.00	1.00	0.00				1.00	1.00	0.00
Uniform Delay (d), s/veh	0.0	14.9	16.9	25.2	4.1	0.0				28.9	26.6	0.0
Incr Delay (d2), s/veh	0.0	0.8	5.1	25.5	0.6	0.0				16.1	0.5	0.0
Initial Q Delay(d3),s/veh	0.0	0.0	0.0	0.0	0.0	0.0				0.0	0.0	0.0
%ile BackOfQ(50%),veh/ln	0.0	3.0	5.5	9.6	2.2	0.0				4.3	1.0	0.0
Unsig. Movement Delay, s/veh												
LnGrp Delay(d),s/veh	0.0	15.7	22.0	50.7	4.7	0.0				45.0	27.1	0.0
LnGrp LOS	A	B	C	D	A	A				D	C	
Approach Vol, veh/h		974			1579						275	
Approach Delay, s/veh		18.4			17.2						40.5	
Approach LOS		B			B						D	
Timer - Assigned Phs		2			5	6		8				
Phs Duration (G+Y+Rc), s		55.0			22.0	33.0		14.7				
Change Period (Y+Rc), s		5.1			4.0	5.1		4.7				
Max Green Setting (Gmax), s		49.9			18.0	27.9		10.3				
Max Q Clear Time (g_c+I1), s		11.5			18.3	16.6		9.8				
Green Ext Time (p_c), s		10.5			0.0	4.0		0.1				

Intersection Summary























HCM 6th Ctrl Delay	19.9
HCM 6th LOS	B

Notes

- User approved volume balancing among the lanes for turning movement.
- User approved ignoring U-Turning movement.
- Unsignalized Delay for [SBR] is excluded from calculations of the approach delay and intersection delay.

HCM 6th Signalized Intersection Summary  
 1: Old Redwood Hwy & Shiloh Road

Existing Project Alter. B Conditions  
 Timing Plan: Saturday Midday Peak

												
Movement	EBL	EBT	EBR	WBL	WBT	WBR	NBL	NBT	NBR	SBL	SBT	SBR
Lane Configurations												
Traffic Volume (veh/h)	123	441	231	21	476	69	243	242	24	69	196	180
Future Volume (veh/h)	123	441	231	21	476	69	243	242	24	69	196	180
Initial Q (Qb), veh	0	0	0	0	0	0	0	0	0	0	0	0
Ped-Bike Adj(A_pbT)	1.00		0.97	1.00		1.00	1.00		0.98	1.00		0.97
Parking Bus, Adj	1.00	1.00	1.00	1.00	1.00	1.00	1.00	1.00	1.00	1.00	1.00	1.00
Work Zone On Approach		No			No			No			No	
Adj Sat Flow, veh/h/ln	1870	1870	1870	1870	1870	1870	1870	1870	1870	1870	1870	1870
Adj Flow Rate, veh/h	138	496	260	24	553	80	261	260	26	76	215	198
Peak Hour Factor	0.89	0.89	0.89	0.86	0.86	0.86	0.93	0.93	0.93	0.91	0.91	0.91
Percent Heavy Veh, %	2	2	2	2	2	2	2	2	2	2	2	2
Cap, veh/h	458	481	396	25	574	508	218	426	353	90	292	240
Arrive On Green	0.26	0.26	0.26	0.32	0.32	0.32	0.12	0.23	0.23	0.05	0.16	0.16
Sat Flow, veh/h	1781	1870	1539	78	1789	1585	1781	1870	1551	1781	1870	1535
Grp Volume(v), veh/h	138	496	260	577	0	80	261	260	26	76	215	198
Grp Sat Flow(s),veh/h/ln	1781	1870	1539	1866	0	1585	1781	1870	1551	1781	1870	1535
Q Serve(g_s), s	7.4	30.5	17.9	36.0	0.0	4.3	14.5	14.8	1.6	5.0	13.0	14.8
Cycle Q Clear(g_c), s	7.4	30.5	17.9	36.0	0.0	4.3	14.5	14.8	1.6	5.0	13.0	14.8
Prop In Lane	1.00		1.00	0.04		1.00	1.00		1.00	1.00		1.00
Lane Grp Cap(c), veh/h	458	481	396	599	0	508	218	426	353	90	292	240
V/C Ratio(X)	0.30	1.03	0.66	0.96	0.00	0.16	1.20	0.61	0.07	0.84	0.74	0.83
Avail Cap(c_a), veh/h	458	481	396	599	0	508	218	687	569	90	552	453
HCM Platoon Ratio	1.00	1.00	1.00	1.00	1.00	1.00	1.00	1.00	1.00	1.00	1.00	1.00
Upstream Filter(I)	1.00	1.00	1.00	1.00	0.00	1.00	1.00	1.00	1.00	1.00	1.00	1.00
Uniform Delay (d), s/veh	35.4	44.0	39.3	39.6	0.0	28.8	52.0	41.0	35.9	55.8	47.7	48.4
Incr Delay (d2), s/veh	0.4	49.0	3.9	27.9	0.0	0.1	124.6	1.4	0.1	48.0	3.6	7.1
Initial Q Delay(d3),s/veh	0.0	0.0	0.0	0.0	0.0	0.0	0.0	0.0	0.0	0.0	0.0	0.0
%ile BackOfQ(50%),veh/ln	3.2	20.2	7.0	20.5	0.0	1.6	13.8	6.8	0.6	3.4	6.2	6.0
Unsig. Movement Delay, s/veh												
LnGrp Delay(d),s/veh	35.8	93.0	43.2	67.5	0.0	28.9	176.6	42.4	36.0	103.8	51.3	55.5
LnGrp LOS	D	F	D	E	A	C	F	D	D	F	D	E
Approach Vol, veh/h		894			657			547			489	
Approach Delay, s/veh		69.7			62.8			106.1			61.2	
Approach LOS		E			E			F			E	
Timer - Assigned Phs		2	3	4		6	7	8				
Phs Duration (G+Y+Rc), s		35.0	18.0	23.0		42.5	9.5	31.5				
Change Period (Y+Rc), s		4.5	3.5	4.5		4.5	3.5	4.5				
Max Green Setting (Gmax), s		30.5	14.5	35.0		38.0	6.0	43.5				
Max Q Clear Time (g_c+I1), s		32.5	16.5	16.8		38.0	7.0	16.8				
Green Ext Time (p_c), s		0.0	0.0	1.7		0.0	0.0	1.4				
<b>Intersection Summary</b>												
HCM 6th Ctrl Delay			74.0									
HCM 6th LOS			E									

HCM Signalized Intersection Capacity Analysis  
2: Shiloh Road & Hembree Ln

Existing Project Alter. B Conditions  
Timing Plan: Saturday Midday Peak

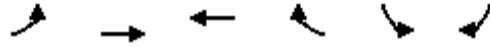

Movement	EBL	EBT	WBT	WBR	SBL	SBR
Lane Configurations	↔↔	↑	↕↔		↔	↔
Traffic Volume (vph)	622	707	700	159	160	580
Future Volume (vph)	622	707	700	159	160	580
Ideal Flow (vphpl)	1900	1900	1900	1900	1900	1900
Total Lost time (s)	4.0	4.0	4.0		4.0	4.0
Lane Util. Factor	0.97	1.00	0.95		1.00	1.00
Frpb, ped/bikes	1.00	1.00	1.00		1.00	1.00
Flpb, ped/bikes	1.00	1.00	1.00		1.00	1.00
Frt	1.00	1.00	0.97		1.00	0.85
Flt Protected	0.95	1.00	1.00		0.95	1.00
Satd. Flow (prot)	3433	1863	3433		1770	1583
Flt Permitted	0.95	1.00	1.00		0.95	1.00
Satd. Flow (perm)	3433	1863	3433		1770	1583
Peak-hour factor, PHF	0.94	0.94	0.96	0.96	0.91	0.91
Adj. Flow (vph)	662	752	729	166	176	637
RTOR Reduction (vph)	0	0	25	0	0	67
Lane Group Flow (vph)	662	752	870	0	176	570
Confl. Peds. (#/hr)	1			1		
Turn Type	Prot	NA	NA		Perm	pm+ov
Protected Phases	5	2	6			5
Permitted Phases					4	4 5
Actuated Green, G (s)	20.1	49.4	25.3		11.5	31.6
Effective Green, g (s)	20.1	49.4	25.3		11.5	31.6
Actuated g/C Ratio	0.29	0.72	0.37		0.17	0.46
Clearance Time (s)	4.0	4.0	4.0		4.0	4.0
Vehicle Extension (s)	3.0	3.0	3.0		3.0	3.0
Lane Grp Cap (vph)	1001	1335	1260		295	817
v/s Ratio Prot	0.19	0.40	c0.25			c0.20
v/s Ratio Perm					0.10	0.16
v/c Ratio	0.66	0.56	0.69		0.60	0.70
Uniform Delay, d1	21.4	4.6	18.5		26.6	14.8
Progression Factor	1.00	1.00	1.00		1.00	1.00
Incremental Delay, d2	1.7	0.5	1.7		3.2	2.6
Delay (s)	23.1	5.2	20.1		29.8	17.5
Level of Service	C	A	C		C	B
Approach Delay (s)		13.6	20.1		20.1	
Approach LOS		B	C		C	

Intersection Summary				
HCM 2000 Control Delay		17.2	HCM 2000 Level of Service	B
HCM 2000 Volume to Capacity ratio		0.74		
Actuated Cycle Length (s)		68.9	Sum of lost time (s)	12.0
Intersection Capacity Utilization		67.3%	ICU Level of Service	C
Analysis Period (min)		15		
c	Critical Lane Group			

HCM 6th Signalized Intersection Summary  
 3: US 101 NB Off-Ramp & Shiloh Road

Existing Project Alter. B Conditions  
 Timing Plan: Saturday Midday Peak



Movement	EBT	EBR	WBL	WBT	NBL	NBR
Lane Configurations	↑↑			↑	↘	↗
Traffic Volume (veh/h)	536	0	0	942	352	791
Future Volume (veh/h)	536	0	0	942	352	791
Initial Q (Qb), veh	0	0	0	0	0	0
Ped-Bike Adj(A_pbT)		1.00	1.00		1.00	1.00
Parking Bus, Adj	1.00	1.00	1.00	1.00	1.00	1.00
Work Zone On Approach	No			No	No	
Adj Sat Flow, veh/h/ln	1870	0	0	1870	1870	1870
Adj Flow Rate, veh/h	589	0	0	1058	371	833
Peak Hour Factor	0.91	0.91	0.89	0.89	0.95	0.95
Percent Heavy Veh, %	2	0	0	2	2	2
Cap, veh/h	1818	0	0	957	649	1016
Arrive On Green	0.51	0.00	0.00	0.51	0.36	0.36
Sat Flow, veh/h	3741	0	0	1870	1781	2790
Grp Volume(v), veh/h	589	0	0	1058	371	833
Grp Sat Flow(s),veh/h/ln	1777	0	0	1870	1781	1395
Q Serve(g_s), s	6.3	0.0	0.0	33.0	10.8	17.5
Cycle Q Clear(g_c), s	6.3	0.0	0.0	33.0	10.8	17.5
Prop In Lane		0.00	0.00		1.00	1.00
Lane Grp Cap(c), veh/h	1818	0	0	957	649	1016
V/C Ratio(X)	0.32	0.00	0.00	1.11	0.57	0.82
Avail Cap(c_a), veh/h	1818	0	0	957	856	1341
HCM Platoon Ratio	1.00	1.00	1.00	1.00	1.00	1.00
Upstream Filter(I)	1.00	0.00	0.00	1.00	1.00	1.00
Uniform Delay (d), s/veh	9.2	0.0	0.0	15.7	16.5	18.6
Incr Delay (d2), s/veh	0.1	0.0	0.0	62.4	0.8	3.1
Initial Q Delay(d3),s/veh	0.0	0.0	0.0	0.0	0.0	0.0
%ile BackOfQ(50%),veh/ln	1.9	0.0	0.0	27.2	4.1	5.5
Unsig. Movement Delay, s/veh						
LnGrp Delay(d),s/veh	9.3	0.0	0.0	78.2	17.3	21.7
LnGrp LOS	A	A	A	F	B	C
Approach Vol, veh/h	589			1058	1204	
Approach Delay, s/veh	9.3			78.2	20.4	
Approach LOS	A			E	C	
Timer - Assigned Phs		2			6	8
Phs Duration (G+Y+Rc), s		37.0			37.0	27.5
Change Period (Y+Rc), s		4.0			4.0	4.0
Max Green Setting (Gmax), s		33.0			33.0	31.0
Max Q Clear Time (g_c+I1), s		8.3			35.0	19.5
Green Ext Time (p_c), s		3.9			0.0	4.0
<b>Intersection Summary</b>						
HCM 6th Ctrl Delay			39.5			
HCM 6th LOS			D			

HCM Signalized Intersection Capacity Analysis  
4: Shiloh Road & US 101 SB Off-Ramp

Existing Project Alter. B Conditions  
Timing Plan: Saturday Midday Peak



Movement	EBL	EBT	WBT	WBR	SBL	SBR
Lane Configurations		↑	↑		↘	↘
Traffic Volume (vph)	0	295	548	0	320	151
Future Volume (vph)	0	295	548	0	320	151
Ideal Flow (vphpl)	1900	1900	1900	1900	1900	1900
Total Lost time (s)		4.0	4.0		4.0	4.0
Lane Util. Factor		1.00	1.00		1.00	1.00
Frbp, ped/bikes		1.00	1.00		1.00	1.00
Flpb, ped/bikes		1.00	1.00		1.00	1.00
Frt		1.00	1.00		1.00	0.85
Flt Protected		1.00	1.00		0.95	1.00
Satd. Flow (prot)		1863	1863		1770	1583
Flt Permitted		1.00	1.00		0.95	1.00
Satd. Flow (perm)		1863	1863		1770	1583
Peak-hour factor, PHF	0.96	0.96	0.96	0.96	0.68	0.68
Adj. Flow (vph)	0	307	571	0	471	222
RTOR Reduction (vph)	0	0	0	0	0	135
Lane Group Flow (vph)	0	307	571	0	471	87
Confl. Bikes (#/hr)				2		
Turn Type		NA	NA		Perm	Perm
Protected Phases		2	6			
Permitted Phases					4	4
Actuated Green, G (s)		18.5	18.5		17.2	17.2
Effective Green, g (s)		18.5	18.5		17.2	17.2
Actuated g/C Ratio		0.42	0.42		0.39	0.39
Clearance Time (s)		4.0	4.0		4.0	4.0
Vehicle Extension (s)		3.0	3.0		3.0	3.0
Lane Grp Cap (vph)		788	788		696	623
v/s Ratio Prot		0.16	c0.31			
v/s Ratio Perm					c0.27	0.06
v/c Ratio		0.39	0.72		0.68	0.14
Uniform Delay, d1		8.7	10.5		11.0	8.5
Progression Factor		1.00	1.00		1.00	1.00
Incremental Delay, d2		0.3	3.3		2.6	0.1
Delay (s)		9.0	13.8		13.6	8.6
Level of Service		A	B		B	A
Approach Delay (s)		9.0	13.8		12.0	
Approach LOS		A	B		B	
<b>Intersection Summary</b>						
HCM 2000 Control Delay			12.1		HCM 2000 Level of Service	B
HCM 2000 Volume to Capacity ratio			0.70			
Actuated Cycle Length (s)			43.7		Sum of lost time (s)	8.0
Intersection Capacity Utilization			117.3%		ICU Level of Service	H
Analysis Period (min)			15			
c Critical Lane Group						

Intersection						
Int Delay, s/veh	1.9					
Movement	EBT	EBR	WBL	WBT	NBL	NBR
Lane Configurations	↑↑		↘	↑	↘	↘
Traffic Vol, veh/h	567	20	81	627	16	78
Future Vol, veh/h	567	20	81	627	16	78
Conflicting Peds, #/hr	0	0	0	0	1	0
Sign Control	Free	Free	Free	Free	Stop	Stop
RT Channelized	-	None	-	None	-	None
Storage Length	-	-	68	-	0	0
Veh in Median Storage, #	0	-	-	0	0	-
Grade, %	0	-	-	0	0	-
Peak Hour Factor	92	92	87	87	78	78
Heavy Vehicles, %	2	2	2	2	2	2
Mvmt Flow	616	22	93	721	21	100



















Major/Minor	Major1	Major2	Minor1	Minor2	Minor3
Conflicting Flow All	0	0	638	0	1535 319
Stage 1	-	-	-	-	627 -
Stage 2	-	-	-	-	908 -
Critical Hdwy	-	-	4.13	-	6.63 6.93
Critical Hdwy Stg 1	-	-	-	-	5.83 -
Critical Hdwy Stg 2	-	-	-	-	5.43 -
Follow-up Hdwy	-	-	2.219	-	3.519 3.319
Pot Cap-1 Maneuver	-	-	944	-	117 677
Stage 1	-	-	-	-	496 -
Stage 2	-	-	-	-	392 -
Platoon blocked, %	-	-	-	-	-
Mov Cap-1 Maneuver	-	-	944	-	105 677
Mov Cap-2 Maneuver	-	-	-	-	105 -
Stage 1	-	-	-	-	496 -
Stage 2	-	-	-	-	353 -

Approach	EB	WB	NB
HCM Control Delay, s	0	1.1	17.4
HCM LOS			C

Minor Lane/Major Mvmt	NBLn1	NBLn2	EBT	EBR	WBL	WBT
Capacity (veh/h)	105	677	-	-	944	-
HCM Lane V/C Ratio	0.195	0.148	-	-	0.099	-
HCM Control Delay (s)	47.4	11.2	-	-	9.2	-
HCM Lane LOS	E	B	-	-	A	-
HCM 95th %tile Q(veh)	0.7	0.5	-	-	0.3	-

HCM Signalized Intersection Capacity Analysis  
6: Conde Lane & Shiloh Road

Existing Project Alter. B Conditions  
Timing Plan: Saturday Midday Peak

												
Movement	EBL	EBT	EBR	WBL	WBT	WBR	NBL	NBT	NBR	SBL	SBT	SBR
Lane Configurations												
Traffic Volume (vph)	29	383	1	9	426	204	1	0	6	197	0	28
Future Volume (vph)	29	383	1	9	426	204	1	0	6	197	0	28
Ideal Flow (vphp)	1900	1900	1900	1900	1900	1900	1900	1900	1900	1900	1900	1900
Total Lost time (s)	4.0	4.0		4.0	4.0			4.0			4.0	4.0
Lane Util. Factor	1.00	0.95		1.00	0.95			1.00			1.00	1.00
Frbp, ped/bikes	1.00	1.00		1.00	0.99			1.00			1.00	1.00
Flpb, ped/bikes	1.00	1.00		1.00	1.00			1.00			1.00	1.00
Frt	1.00	1.00		1.00	0.95			0.89			1.00	0.85
Flt Protected	0.95	1.00		0.95	1.00			0.99			0.95	1.00
Satd. Flow (prot)	1770	3538		1770	3343			1640			1770	1583
Flt Permitted	0.95	1.00		0.95	1.00			0.99			0.95	1.00
Satd. Flow (perm)	1770	3538		1770	3343			1640			1770	1583
Peak-hour factor, PHF	0.96	0.96	0.96	0.91	0.91	0.91	0.58	0.58	0.58	0.78	0.78	0.78
Adj. Flow (vph)	30	399	1	10	468	224	2	0	10	253	0	36
RTOR Reduction (vph)	0	0	0	0	55	0	0	12	0	0	0	0
Lane Group Flow (vph)	30	400	0	10	637	0	0	0	0	0	253	36
Confl. Bikes (#/hr)						2						
Turn Type	Prot	NA		Prot	NA		Split	NA		Split	NA	custom
Protected Phases	5	2		1	6		7	7		4	4	
Permitted Phases												6
Actuated Green, G (s)	0.9	15.2		0.9	15.2			1.1			12.3	15.2
Effective Green, g (s)	0.9	15.2		0.9	15.2			1.1			12.3	15.2
Actuated g/C Ratio	0.02	0.33		0.02	0.33			0.02			0.27	0.33
Clearance Time (s)	4.0	4.0		4.0	4.0			4.0			4.0	4.0
Vehicle Extension (s)	3.0	3.0		3.0	3.0			3.0			3.0	3.0
Lane Grp Cap (vph)	35	1181		35	1116			39			478	528
v/s Ratio Prot	c0.02	0.11		0.01	c0.19			c0.00			c0.14	
v/s Ratio Perm												0.02
v/c Ratio	0.86	0.34		0.29	0.57			0.01			0.53	0.07
Uniform Delay, d1	22.2	11.4		22.0	12.5			21.7			14.1	10.3
Progression Factor	1.00	1.00		1.00	1.00			1.00			1.00	1.00
Incremental Delay, d2	94.8	0.2		4.5	0.7			0.1			1.1	0.1
Delay (s)	117.0	11.5		26.4	13.2			21.7			15.2	10.4
Level of Service	F	B		C	B			C			B	B
Approach Delay (s)		18.9			13.4			21.7			14.6	
Approach LOS		B			B			C			B	
<b>Intersection Summary</b>												
HCM 2000 Control Delay			15.3			HCM 2000 Level of Service				B		
HCM 2000 Volume to Capacity ratio			0.54									
Actuated Cycle Length (s)			45.5			Sum of lost time (s)			16.0			
Intersection Capacity Utilization			48.3%			ICU Level of Service				A		
Analysis Period (min)			15									
c Critical Lane Group												



HCM 6th TWSC  
7: Driveway 1/Gridley Drive & Shiloh Road

Existing Project Alter. B Conditions  
Timing Plan: Saturday Midday Peak

Intersection												
Int Delay, s/veh	4.5											
Movement	EBL	EBT	EBR	WBL	WBT	WBR	NBL	NBT	NBR	SBL	SBT	SBR
Lane Configurations		↕	↗		↕		↗	↘			↕	
Traffic Vol, veh/h	20	422	103	0	438	0	113	0	0	0	0	18
Future Vol, veh/h	20	422	103	0	438	0	113	0	0	0	0	18
Conflicting Peds, #/hr	1	0	0	0	0	0	0	0	0	0	0	0
Sign Control	Free	Free	Free	Free	Free	Free	Stop	Stop	Stop	Stop	Stop	Stop
RT Channelized	-	-	None	-	-	None	-	-	None	-	-	None
Storage Length	-	-	150	-	-	-	0	-	-	-	-	-
Veh in Median Storage, #	-	0	-	-	0	-	-	0	-	-	0	-
Grade, %	-	0	-	-	0	-	-	0	-	-	0	-
Peak Hour Factor	93	93	93	88	88	88	100	100	100	56	56	56
Heavy Vehicles, %	2	2	2	2	2	2	2	2	2	2	2	2
Mvmt Flow	22	454	111	0	498	0	113	0	0	0	0	32

Major/Minor	Major1			Major2			Minor1			Minor2		
Conflicting Flow All	499	0	0	565	0	0	1012	997	454	1053	1108	499
Stage 1	-	-	-	-	-	-	498	498	-	499	499	-
Stage 2	-	-	-	-	-	-	514	499	-	554	609	-
Critical Hdwy	4.12	-	-	4.12	-	-	7.12	6.52	6.22	7.12	6.52	6.22
Critical Hdwy Stg 1	-	-	-	-	-	-	6.12	5.52	-	6.12	5.52	-
Critical Hdwy Stg 2	-	-	-	-	-	-	6.12	5.52	-	6.12	5.52	-
Follow-up Hdwy	2.218	-	-	2.218	-	-	3.518	4.018	3.318	3.518	4.018	3.318
Pot Cap-1 Maneuver	1065	-	-	1007	-	-	218	244	606	204	210	572
Stage 1	-	-	-	-	-	-	554	544	-	554	544	-
Stage 2	-	-	-	-	-	-	543	544	-	517	485	-
Platoon blocked, %		-	-		-	-						
Mov Cap-1 Maneuver	1064	-	-	1007	-	-	201	236	606	199	203	571
Mov Cap-2 Maneuver	-	-	-	-	-	-	201	236	-	199	203	-
Stage 1	-	-	-	-	-	-	537	527	-	536	543	-
Stage 2	-	-	-	-	-	-	512	543	-	501	470	-

Approach	EB	WB	NB	SB
HCM Control Delay, s	0.3	0	43.7	11.7
HCM LOS			E	B

Minor Lane/Major Mvmt	NBLn1	NBLn2	EBL	EBT	EBR	WBL	WBT	WBR	SBLn1
Capacity (veh/h)	201	-	1064	-	-	1007	-	-	571
HCM Lane V/C Ratio	0.562	-	0.02	-	-	-	-	-	0.056
HCM Control Delay (s)	43.7	0	8.5	0	-	0	-	-	11.7
HCM Lane LOS	E	A	A	A	-	A	-	-	B
HCM 95th %tile Q(veh)	3	-	0.1	-	-	0	-	-	0.2

HCM 6th TWSC  
8: Old Redwood Hwy & Driveway 2

Existing Project Alter. B Conditions  
Timing Plan: Saturday Midday Peak

Intersection												
Int Delay, s/veh	3.9											
Movement	EBL	EBT	EBR	WBL	WBT	WBR	NBL	NBT	NBR	SBL	SBT	SBR
Lane Configurations		↕		↕	↕			↕	↕	↕	↕	
Traffic Vol, veh/h	1	0	2	67	0	106	1	403	61	97	342	4
Future Vol, veh/h	1	0	2	67	0	106	1	403	61	97	342	4
Conflicting Peds, #/hr	0	0	0	0	0	0	1	0	4	4	0	1
Sign Control	Stop	Stop	Stop	Stop	Stop	Stop	Free	Free	Free	Free	Free	Free
RT Channelized	-	-	None	-	-	None	-	-	None	-	-	None
Storage Length	-	-	-	0	-	-	-	-	100	50	-	-
Veh in Median Storage, #	-	0	-	-	0	-	-	0	-	-	0	-
Grade, %	-	0	-	-	0	-	-	0	-	-	0	-
Peak Hour Factor	38	38	38	100	100	100	94	94	94	93	93	93
Heavy Vehicles, %	2	2	2	2	2	2	2	2	2	2	2	2
Mvmt Flow	3	0	5	67	0	106	1	429	65	104	368	4

Major/Minor	Minor2		Minor1		Major1		Major2					
Conflicting Flow All	1096	1079	371	1016	1016	433	373	0	0	498	0	0
Stage 1	579	579	-	435	435	-	-	-	-	-	-	-
Stage 2	517	500	-	581	581	-	-	-	-	-	-	-
Critical Hdwy	7.12	6.52	6.22	7.12	6.52	6.22	4.12	-	-	4.12	-	-
Critical Hdwy Stg 1	6.12	5.52	-	6.12	5.52	-	-	-	-	-	-	-
Critical Hdwy Stg 2	6.12	5.52	-	6.12	5.52	-	-	-	-	-	-	-
Follow-up Hdwy	3.518	4.018	3.318	3.518	4.018	3.318	2.218	-	-	2.218	-	-
Pot Cap-1 Maneuver	191	218	675	216	238	623	1185	-	-	1066	-	-
Stage 1	501	501	-	600	580	-	-	-	-	-	-	-
Stage 2	541	543	-	499	500	-	-	-	-	-	-	-
Platoon blocked, %								-	-	-	-	-
Mov Cap-1 Maneuver	146	196	674	197	213	621	1184	-	-	1062	-	-
Mov Cap-2 Maneuver	146	196	-	197	213	-	-	-	-	-	-	-
Stage 1	500	451	-	597	577	-	-	-	-	-	-	-
Stage 2	448	540	-	447	451	-	-	-	-	-	-	-

Approach	EB	WB	NB	SB
HCM Control Delay, s	17.1	19.9	0	1.9
HCM LOS	C	C		

Minor Lane/Major Mvmt	NBL	NBT	NBR	EBLn1	WBLn1	WBLn2	SBL	SBT	SBR
Capacity (veh/h)	1184	-	-	306	197	621	1062	-	-
HCM Lane V/C Ratio	0.001	-	-	0.026	0.34	0.171	0.098	-	-
HCM Control Delay (s)	8	0	-	17.1	32.4	12	8.8	-	-
HCM Lane LOS	A	A	-	C	D	B	A	-	-
HCM 95th %tile Q(veh)	0	-	-	0.1	1.4	0.6	0.3	-	-

Intersection						
Int Delay, s/veh	6.2					
Movement	EBT	EBR	WBL	WBT	NBL	NBR
Lane Configurations	↑	↗		↖	↖	↗
Traffic Vol, veh/h	92	316	30	86	346	33
Future Vol, veh/h	92	316	30	86	346	33
Conflicting Peds, #/hr	0	1	0	0	0	0
Sign Control	Free	Free	Free	Free	Stop	Stop
RT Channelized	-	None	-	None	-	None
Storage Length	-	200	-	-	0	0
Veh in Median Storage, #	0	-	-	0	0	-
Grade, %	0	-	-	0	0	-
Peak Hour Factor	88	88	80	80	100	100
Heavy Vehicles, %	2	2	2	2	2	2
Mvmt Flow	105	359	38	108	346	33

Major/Minor	Major1	Major2	Minor1		
Conflicting Flow All	0	0	465	0	290
Stage 1	-	-	-	-	106
Stage 2	-	-	-	-	184
Critical Hdwy	-	-	4.12	-	6.42
Critical Hdwy Stg 1	-	-	-	-	5.42
Critical Hdwy Stg 2	-	-	-	-	5.42
Follow-up Hdwy	-	-	2.218	-	3.518
Pot Cap-1 Maneuver	-	-	1096	-	701
Stage 1	-	-	-	-	918
Stage 2	-	-	-	-	848
Platoon blocked, %	-	-	-	-	-
Mov Cap-1 Maneuver	-	-	1095	-	674
Mov Cap-2 Maneuver	-	-	-	-	674
Stage 1	-	-	-	-	917
Stage 2	-	-	-	-	817

Approach	EB	WB	NB
HCM Control Delay, s	0	2.2	15.2
HCM LOS			C

Minor Lane/Major Mvmt	NBLn1	NBLn2	EBT	EBR	WBL	WBT
Capacity (veh/h)	674	947	-	-	1095	-
HCM Lane V/C Ratio	0.513	0.035	-	-	0.034	-
HCM Control Delay (s)	15.8	8.9	-	-	8.4	0
HCM Lane LOS	C	A	-	-	A	A
HCM 95th %tile Q(veh)	3	0.1	-	-	0.1	-

HCM 6th Signalized Intersection Summary

Existing Project Alter. B Conditions

10: US 101 NB Off Ramp/Lakewood Drive & Old Redwood Highway Timing Plan: Saturday Midday Peak



Movement	EBL	EBT	EBR	WBL	WBT	WBR	NBL	NBT	NBR	SBL	SBT	SBR
Lane Configurations												
Traffic Volume (veh/h)	252	336	0	0	508	242	281	266	125	214	0	615
Future Volume (veh/h)	252	336	0	0	508	242	281	266	125	214	0	615
Initial Q (Qb), veh	0	0	0	0	0	0	0	0	0	0	0	0
Ped-Bike Adj(A_pbT)	1.00		1.00	1.00		0.99	1.00		1.00	1.00		1.00
Parking Bus, Adj	1.00	1.00	1.00	1.00	1.00	1.00	1.00	1.00	1.00	1.00	1.00	1.00
Work Zone On Approach		No			No			No			No	
Adj Sat Flow, veh/h/ln	1870	1870	0	0	1870	1870	1870	1870	1870	1870	0	1870
Adj Flow Rate, veh/h	265	354	0	0	571	272	229	353	128	243	0	0
Peak Hour Factor	0.95	0.95	0.95	0.89	0.89	0.89	0.98	0.98	0.98	0.88	0.88	0.88
Percent Heavy Veh, %	2	2	0	0	2	2	2	2	2	2	0	2
Cap, veh/h	377	1183	0	0	1070	509	380	562	200	0	0	0
Arrive On Green	0.11	0.63	0.00	0.00	0.46	0.46	0.21	0.21	0.21	0.00	0.00	0.00
Sat Flow, veh/h	3456	1870	0	0	2417	1105	1781	2632	938		0	
Grp Volume(v), veh/h	265	354	0	0	436	407	229	249	232		0.0	
Grp Sat Flow(s),veh/h/ln	1728	1870	0	0	1777	1652	1781	1870	1700			
Q Serve(g_s), s	4.7	5.5	0.0	0.0	11.2	11.2	7.4	7.7	7.9			
Cycle Q Clear(g_c), s	4.7	5.5	0.0	0.0	11.2	11.2	7.4	7.7	7.9			
Prop In Lane	1.00		0.00	0.00		0.67	1.00		0.55			
Lane Grp Cap(c), veh/h	377	1183	0	0	818	760	380	399	363			
V/C Ratio(X)	0.70	0.30	0.00	0.00	0.53	0.53	0.60	0.62	0.64			
Avail Cap(c_a), veh/h	435	1183	0	0	818	760	813	853	775			
HCM Platoon Ratio	1.00	1.00	1.00	1.00	1.00	1.00	1.00	1.00	1.00			
Upstream Filter(I)	1.00	1.00	0.00	0.00	1.00	1.00	1.00	1.00	1.00			
Uniform Delay (d), s/veh	27.3	5.3	0.0	0.0	12.3	12.3	22.6	22.7	22.8			
Incr Delay (d2), s/veh	4.2	0.6	0.0	0.0	2.5	2.7	1.5	1.6	1.9			
Initial Q Delay(d3),s/veh	0.0	0.0	0.0	0.0	0.0	0.0	0.0	0.0	0.0			
%ile BackOfQ(50%),veh/ln	2.0	1.7	0.0	0.0	4.3	4.0	3.1	3.3	3.1			
Unsig. Movement Delay, s/veh												
LnGrp Delay(d),s/veh	31.6	5.9	0.0	0.0	14.8	15.0	24.1	24.3	24.6			
LnGrp LOS	C	A	A	A	B	B	C	C	C			
Approach Vol, veh/h		619			843			710				
Approach Delay, s/veh		16.9			14.9			24.3				
Approach LOS		B			B			C				
Timer - Assigned Phs		2			5	6		8				
Phs Duration (G+Y+Rc), s		45.3			10.9	34.4		18.3				
Change Period (Y+Rc), s		5.1			4.0	5.1		4.7				
Max Green Setting (Gmax), s		40.2			8.0	28.2		29.0				
Max Q Clear Time (g_c+I1), s		7.5			6.7	13.2		9.9				
Green Ext Time (p_c), s		2.2			0.1	4.7		3.5				

Intersection Summary

HCM 6th Ctrl Delay	18.5
HCM 6th LOS	B

Notes

User approved volume balancing among the lanes for turning movement.  
 Unsignalized Delay for [SBR] is excluded from calculations of the approach delay and intersection delay.

# HCM 6th Signalized Intersection Summary

# Existing Project Alter. B Conditions

12: US 101 SB On Ramp/US 101 SB Off Ramp & Old Redwood Highway Timing Plan: Saturday Midday Peak



Movement	EBL	EBT	EBR	WBL	WBT	WBR	NBL	NBT	NBR	SBL	SBT	SBR
Lane Configurations		↑↑	↗	↘	↑↑					↖	↕	
Traffic Volume (veh/h)	0	483	368	428	718	0	0	0	0	194	1	76
Future Volume (veh/h)	0	483	368	428	718	0	0	0	0	194	1	76
Initial Q (Qb), veh	0	0	0	0	0	0				0	0	0
Ped-Bike Adj(A_pbT)	1.00		0.98	1.00		1.00				1.00		1.00
Parking Bus, Adj	1.00	1.00	1.00	1.00	1.00	1.00				1.00	1.00	1.00
Work Zone On Approach		No			No						No	
Adj Sat Flow, veh/h/ln	0	1870	1870	1870	1870	0				1870	1870	1870
Adj Flow Rate, veh/h	0	498	379	446	748	0				188	114	0
Peak Hour Factor	0.97	0.97	0.97	0.96	0.96	0.96				0.72	0.72	0.72
Percent Heavy Veh, %	0	2	2	2	2	0				2	2	2
Cap, veh/h	0	1381	604	484	2550	0				254	267	
Arrive On Green	0.00	0.39	0.39	0.27	0.72	0.00				0.14	0.14	0.00
Sat Flow, veh/h	0	3647	1555	1781	3647	0				1781	1870	0
Grp Volume(v), veh/h	0	498	379	446	748	0				188	114	0
Grp Sat Flow(s),veh/h/ln	0	1777	1555	1781	1777	0				1781	1870	0
Q Serve(g_s), s	0.0	7.0	13.8	17.0	5.3	0.0				7.1	3.9	0.0
Cycle Q Clear(g_c), s	0.0	7.0	13.8	17.0	5.3	0.0				7.1	3.9	0.0
Prop In Lane	0.00		1.00	1.00		0.00				1.00		0.00
Lane Grp Cap(c), veh/h	0	1381	604	484	2550	0				254	267	
V/C Ratio(X)	0.00	0.36	0.63	0.92	0.29	0.00				0.74	0.43	
Avail Cap(c_a), veh/h	0	1381	604	484	2550	0				255	267	
HCM Platoon Ratio	1.00	1.00	1.00	1.00	1.00	1.00				1.00	1.00	1.00
Upstream Filter(I)	0.00	1.00	1.00	1.00	1.00	0.00				1.00	1.00	0.00
Uniform Delay (d), s/veh	0.0	15.2	17.3	24.8	3.5	0.0				28.8	27.4	0.0
Incr Delay (d2), s/veh	0.0	0.7	4.9	23.2	0.3	0.0				10.9	1.1	0.0
Initial Q Delay(d3),s/veh	0.0	0.0	0.0	0.0	0.0	0.0				0.0	0.0	0.0
%ile BackOfQ(50%),veh/ln	0.0	2.7	5.2	9.7	1.2	0.0				3.7	1.8	0.0
Unsig. Movement Delay, s/veh												
LnGrp Delay(d),s/veh	0.0	15.9	22.2	48.0	3.8	0.0				39.7	28.5	0.0
LnGrp LOS	A	B	C	D	A	A				D	C	
Approach Vol, veh/h		877				1194				302		
Approach Delay, s/veh		18.6				20.3				35.5		
Approach LOS		B				C				D		
Timer - Assigned Phs		2				5		6		8		
Phs Duration (G+Y+Rc), s		55.3				23.0		32.3		14.7		
Change Period (Y+Rc), s		5.1				4.0		5.1		4.7		
Max Green Setting (Gmax), s		50.2				19.0		27.2		10.0		
Max Q Clear Time (g_c+I1), s		7.3				19.0		15.8		9.1		
Green Ext Time (p_c), s		5.9				0.0		3.6		0.1		

### Intersection Summary

HCM 6th Ctrl Delay	21.6
HCM 6th LOS	C

### Notes

- User approved volume balancing among the lanes for turning movement.
- User approved ignoring U-Turning movement.
- Unsignalized Delay for [SBR] is excluded from calculations of the approach delay and intersection delay.

Queues  
1: Old Redwood Hwy & Shiloh Road

Existing Project Alter. B Conditions  
Timing Plan: A.M. PEAK



Lane Group	EBL	EBT	EBR	WBT	WBR	NBL	NBT	NBR	SBL	SBT	SBR
Lane Group Flow (vph)	133	338	128	217	29	99	134	37	41	275	199
v/c Ratio	0.28	0.68	0.26	0.59	0.07	0.44	0.24	0.07	0.31	0.64	0.44
Control Delay	31.3	39.3	11.0	42.8	0.3	48.4	26.9	0.7	54.0	40.7	17.3
Queue Delay	0.0	0.0	0.0	0.0	0.0	0.0	0.0	0.0	0.0	0.0	0.0
Total Delay	31.3	39.3	11.0	42.8	0.3	48.4	26.9	0.7	54.0	40.7	17.3
Queue Length 50th (ft)	58	167	9	111	0	52	58	0	22	140	35
Queue Length 95th (ft)	122	295	49	224	0	128	123	3	65	255	101
Internal Link Dist (ft)		1709		528			668			695	
Turn Bay Length (ft)	375		140		50	200		98	130		93
Base Capacity (vph)	689	726	681	899	822	327	1035	913	135	833	760
Starvation Cap Reductn	0	0	0	0	0	0	0	0	0	0	0
Spillback Cap Reductn	0	0	0	0	0	0	0	0	0	0	0
Storage Cap Reductn	0	0	0	0	0	0	0	0	0	0	0
Reduced v/c Ratio	0.19	0.47	0.19	0.24	0.04	0.30	0.13	0.04	0.30	0.33	0.26

Intersection Summary

Queues

2: Shiloh Road & Hembree Ln

Existing Project Alter. B Conditions

Timing Plan: A.M. PEAK

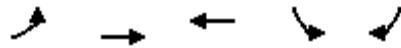

Lane Group	EBL	EBT	WBT	SBL	SBR
Lane Group Flow (vph)	347	493	474	76	384
v/c Ratio	0.35	0.34	0.43	0.21	0.43
Control Delay	13.9	3.9	12.7	17.9	3.0
Queue Delay	0.0	0.0	0.0	0.0	0.0
Total Delay	13.9	3.9	12.7	17.9	3.0
Queue Length 50th (ft)	33	44	44	15	5
Queue Length 95th (ft)	72	94	93	51	38
Internal Link Dist (ft)		222	1709	301	
Turn Bay Length (ft)					
Base Capacity (vph)	2455	1863	3179	684	1428
Starvation Cap Reductn	0	0	0	0	0
Spillback Cap Reductn	0	0	0	0	0
Storage Cap Reductn	0	0	0	0	0
Reduced v/c Ratio	0.14	0.26	0.15	0.11	0.27

Intersection Summary

Queues  
3: US 101 NB Off-Ramp & Shiloh Road

Existing Project Alter. B Conditions  
Timing Plan: A.M. PEAK

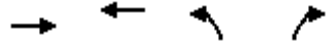

Lane Group	EBT	WBT	NBL	NBR
Lane Group Flow (vph)	331	646	568	593
v/c Ratio	0.21	0.80	0.77	0.39
Control Delay	11.2	23.7	24.1	2.2
Queue Delay	0.0	0.0	0.0	0.0
Total Delay	11.2	23.7	24.1	2.2
Queue Length 50th (ft)	37	195	171	0
Queue Length 95th (ft)	68	357	245	10
Internal Link Dist (ft)	106	291	689	
Turn Bay Length (ft)				265
Base Capacity (vph)	2166	1140	1017	1854
Starvation Cap Reductn	0	0	0	0
Spillback Cap Reductn	0	0	0	0
Storage Cap Reductn	0	0	0	0
Reduced v/c Ratio	0.15	0.57	0.56	0.32
<b>Intersection Summary</b>				



Queues  
4: Shiloh Road & US 101 SB Off-Ramp

Existing Project Alter. B Conditions  
Timing Plan: A.M. PEAK

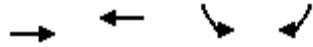

Lane Group	EBT	WBT	SBL	SBR
Lane Group Flow (vph)	258	653	162	150
v/c Ratio	0.26	0.66	0.38	0.30
Control Delay	5.5	10.1	16.7	5.5
Queue Delay	0.0	0.0	0.0	0.0
Total Delay	5.5	10.1	16.7	5.5
Queue Length 50th (ft)	22	75	26	0
Queue Length 95th (ft)	58	180	84	34
Internal Link Dist (ft)	145	226	406	
Turn Bay Length (ft)				275
Base Capacity (vph)	1863	1863	852	839
Starvation Cap Reductn	0	0	0	0
Spillback Cap Reductn	0	0	0	0
Storage Cap Reductn	0	0	0	0
Reduced v/c Ratio	0.14	0.35	0.19	0.18
<b>Intersection Summary</b>				

Queues  
6: Conde Lane & Shiloh Road

Existing Project Alter. B Conditions  
Timing Plan: A.M. PEAK

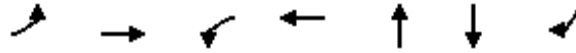

Lane Group	EBL	EBT	WBL	WBT	NBT	SBT	SBR
Lane Group Flow (vph)	26	360	11	665	28	239	41
v/c Ratio	0.07	0.27	0.03	0.55	0.06	0.46	0.08
Control Delay	23.8	11.2	23.9	13.3	0.2	25.0	14.1
Queue Delay	0.0	0.0	0.0	0.0	0.0	0.0	0.0
Total Delay	23.8	11.2	23.9	13.3	0.2	25.0	14.1
Queue Length 50th (ft)	3	18	1	31	0	29	4
Queue Length 95th (ft)	31	88	16	132	0	#196	29
Internal Link Dist (ft)		735		1001	338	442	
Turn Bay Length (ft)	90		127				40
Base Capacity (vph)	422	3021	375	2860	1343	517	1344
Starvation Cap Reductn	0	0	0	0	0	0	0
Spillback Cap Reductn	0	0	0	0	0	0	0
Storage Cap Reductn	0	0	0	0	0	0	0
Reduced v/c Ratio	0.06	0.12	0.03	0.23	0.02	0.46	0.03

Intersection Summary

# 95th percentile volume exceeds capacity, queue may be longer.  
Queue shown is maximum after two cycles.

Queues

10: US 101 NB Off Ramp/Lakewood Drive & Old Redwood Highway

Existing Project Alter. B Conditions

Timing Plan: A.M. PEAK



Lane Group	EBL	EBT	WBT	NBL	NBT	SBL	SBR
Lane Group Flow (vph)	179	208	733	194	392	133	600
v/c Ratio	0.48	0.21	0.58	0.59	0.56	0.42	0.77
Control Delay	37.6	11.6	21.6	35.0	27.4	38.9	17.2
Queue Delay	0.0	0.0	0.0	0.0	0.0	0.0	0.0
Total Delay	37.6	11.6	21.6	35.0	27.4	38.9	17.2
Queue Length 50th (ft)	41	49	135	92	82	31	119
Queue Length 95th (ft)	74	98	198	161	125	62	238
Internal Link Dist (ft)		146	537		636		
Turn Bay Length (ft)	155			270		120	
Base Capacity (vph)	403	976	1262	608	1250	313	791
Starvation Cap Reductn	0	0	0	0	0	0	0
Spillback Cap Reductn	0	0	0	0	0	0	0
Storage Cap Reductn	0	0	0	0	0	0	0
Reduced v/c Ratio	0.44	0.21	0.58	0.32	0.31	0.42	0.76

Intersection Summary

Queues

Existing Project Alter. B Conditions

12: US 101 SB On Ramp/US 101 SB Off Ramp & Old Redwood Highway

Timing Plan: A.M. PEAK



Lane Group	EBT	EBR	WBL	WBT	SBL	SBT
Lane Group Flow (vph)	324	322	576	566	120	109
v/c Ratio	0.26	0.43	0.93	0.21	0.57	0.41
Control Delay	19.6	4.4	48.8	3.1	44.7	17.5
Queue Delay	0.0	0.0	0.0	0.0	0.0	0.0
Total Delay	19.6	4.4	48.8	3.1	44.7	17.5
Queue Length 50th (ft)	61	0	267	34	60	13
Queue Length 95th (ft)	93	52	#451	46	103	50
Internal Link Dist (ft)	343			451		751
Turn Bay Length (ft)			250		420	
Base Capacity (vph)	1245	756	641	2663	210	264
Starvation Cap Reductn	0	0	0	0	0	0
Spillback Cap Reductn	0	0	0	0	0	0
Storage Cap Reductn	0	0	0	0	0	0
Reduced v/c Ratio	0.26	0.43	0.90	0.21	0.57	0.41

Intersection Summary

# 95th percentile volume exceeds capacity, queue may be longer.  
 Queue shown is maximum after two cycles.

Queues  
1: Old Redwood Hwy & Shiloh Road

Existing Project Alter. B Conditions  
Timing Plan: P.M. Peak



Lane Group	EBL	EBT	EBR	WBT	WBR	NBL	NBT	NBR	SBL	SBT	SBR
Lane Group Flow (vph)	248	367	230	406	54	213	371	23	63	260	157
v/c Ratio	0.57	0.81	0.47	0.83	0.11	0.89	0.73	0.05	0.64	0.72	0.41
Control Delay	44.9	55.7	18.9	54.1	0.4	85.7	46.9	0.2	84.4	54.9	18.7
Queue Delay	0.0	0.0	0.0	0.0	0.0	0.0	0.0	0.0	0.0	0.0	0.0
Total Delay	44.9	55.7	18.9	54.1	0.4	85.7	46.9	0.2	84.4	54.9	18.7
Queue Length 50th (ft)	154	245	50	280	0	157	250	0	46	181	32
Queue Length 95th (ft)	285	#469	145	445	0	#369	386	0	#139	289	98
Internal Link Dist (ft)		1709		528			668			695	
Turn Bay Length (ft)	375		140		50	200		98	130		93
Base Capacity (vph)	506	532	553	659	619	240	759	675	99	611	576
Starvation Cap Reductn	0	0	0	0	0	0	0	0	0	0	0
Spillback Cap Reductn	0	0	0	0	0	0	0	0	0	0	0
Storage Cap Reductn	0	0	0	0	0	0	0	0	0	0	0
Reduced v/c Ratio	0.49	0.69	0.42	0.62	0.09	0.89	0.49	0.03	0.64	0.43	0.27

Intersection Summary

# 95th percentile volume exceeds capacity, queue may be longer.  
Queue shown is maximum after two cycles.

Queues

2: Shiloh Road & Hembree Ln

Existing Project Alter. B Conditions

Timing Plan: P.M. Peak



Lane Group	EBL	EBT	WBT	SBL	SBR
Lane Group Flow (vph)	654	712	806	179	517
v/c Ratio	0.65	0.55	0.68	0.57	0.56
Control Delay	24.5	6.6	21.0	35.8	10.2
Queue Delay	0.0	0.0	0.0	0.0	0.0
Total Delay	24.5	6.7	21.0	35.8	10.2
Queue Length 50th (ft)	118	118	136	66	79
Queue Length 95th (ft)	200	183	206	#162	205
Internal Link Dist (ft)		222	1709	301	
Turn Bay Length (ft)					
Base Capacity (vph)	1378	1780	2216	369	1073
Starvation Cap Reductn	0	72	0	0	0
Spillback Cap Reductn	0	0	0	0	0
Storage Cap Reductn	0	0	0	0	0
Reduced v/c Ratio	0.47	0.42	0.36	0.49	0.48

Intersection Summary

# 95th percentile volume exceeds capacity, queue may be longer.  
 Queue shown is maximum after two cycles.

Queues  
3: US 101 NB Off-Ramp & Shiloh Road

Existing Project Alter. B Conditions  
Timing Plan: P.M. Peak

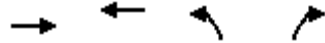

Lane Group	EBT	WBT	NBL	NBR
Lane Group Flow (vph)	513	744	584	897
v/c Ratio	0.32	0.88	0.79	0.63
Control Delay	12.4	31.2	26.4	9.5
Queue Delay	0.0	0.0	0.0	0.0
Total Delay	12.4	31.2	26.4	9.5
Queue Length 50th (ft)	72	284	212	76
Queue Length 95th (ft)	104	#499	#352	138
Internal Link Dist (ft)	106	291	689	
Turn Bay Length (ft)				265
Base Capacity (vph)	1895	997	890	1624
Starvation Cap Reductn	0	0	0	0
Spillback Cap Reductn	0	0	0	0
Storage Cap Reductn	0	0	0	0
Reduced v/c Ratio	0.27	0.75	0.66	0.55

Intersection Summary

# 95th percentile volume exceeds capacity, queue may be longer.  
Queue shown is maximum after two cycles.

Queues  
4: Shiloh Road & US 101 SB Off-Ramp

Existing Project Alter. B Conditions  
Timing Plan: P.M. Peak

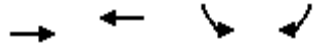

Lane Group	EBT	WBT	SBL	SBR
Lane Group Flow (vph)	500	663	251	118
v/c Ratio	0.52	0.69	0.50	0.23
Control Delay	9.1	12.3	18.0	5.0
Queue Delay	0.0	0.0	0.0	0.0
Total Delay	9.1	12.3	18.0	5.0
Queue Length 50th (ft)	64	96	48	0
Queue Length 95th (ft)	150	229	126	30
Internal Link Dist (ft)	145	226	406	
Turn Bay Length (ft)				275
Base Capacity (vph)	1863	1863	757	730
Starvation Cap Reductn	0	0	0	0
Spillback Cap Reductn	0	0	0	0
Storage Cap Reductn	0	0	0	0
Reduced v/c Ratio	0.27	0.36	0.33	0.16
Intersection Summary				



Queues  
6: Conde Lane & Shiloh Road

Existing Project Alter. B Conditions  
Timing Plan: P.M. Peak

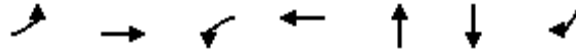

Lane Group	EBL	EBT	WBL	WBT	NBT	SBT	SBR
Lane Group Flow (vph)	78	561	9	957	40	338	44
v/c Ratio	0.29	0.31	0.03	0.70	0.12	0.95	0.07
Control Delay	33.5	10.3	32.1	17.6	17.8	72.3	14.3
Queue Delay	0.0	0.0	0.0	0.0	0.0	0.0	0.0
Total Delay	33.5	10.3	32.1	17.6	17.8	72.3	14.3
Queue Length 50th (ft)	32	65	4	164	5	~188	13
Queue Length 95th (ft)	78	129	16	187	20	#381	31
Internal Link Dist (ft)		735		1001	338	442	
Turn Bay Length (ft)	90		127				40
Base Capacity (vph)	292	2484	259	2326	1007	357	1093
Starvation Cap Reductn	0	0	0	0	0	0	0
Spillback Cap Reductn	0	0	0	0	0	0	0
Storage Cap Reductn	0	0	0	0	0	0	0
Reduced v/c Ratio	0.27	0.23	0.03	0.41	0.04	0.95	0.04

Intersection Summary

- ~ Volume exceeds capacity, queue is theoretically infinite.  
Queue shown is maximum after two cycles.
- # 95th percentile volume exceeds capacity, queue may be longer.  
Queue shown is maximum after two cycles.

Queues

Existing Project Alter. B Conditions

10: US 101 NB Off Ramp/Lakewood Drive & Old Redwood Highway

Timing Plan: P.M. Peak



Lane Group	EBL	EBT	WBT	NBL	NBT	SBL	SBR
Lane Group Flow (vph)	300	454	802	424	840	259	601
v/c Ratio	0.86	0.54	0.74	0.85	0.80	0.95	0.68
Control Delay	64.1	20.8	30.8	46.2	31.9	87.1	13.4
Queue Delay	0.0	0.0	0.0	0.0	0.0	0.0	0.0
Total Delay	64.1	20.8	30.8	46.2	31.9	87.1	13.4
Queue Length 50th (ft)	88	183	201	241	212	77	127
Queue Length 95th (ft)	#151	262	271	#413	290	#153	247
Internal Link Dist (ft)		146	537		636		
Turn Bay Length (ft)	155			270		120	
Base Capacity (vph)	349	847	1079	527	1100	272	889
Starvation Cap Reductn	0	0	0	0	0	0	0
Spillback Cap Reductn	0	0	0	0	0	0	0
Storage Cap Reductn	0	0	0	0	0	0	0
Reduced v/c Ratio	0.86	0.54	0.74	0.80	0.76	0.95	0.68

Intersection Summary

# 95th percentile volume exceeds capacity, queue may be longer.  
 Queue shown is maximum after two cycles.

Queues

Existing Project Alter. B Conditions

12: US 101 SB On Ramp/US 101 SB Off Ramp & Old Redwood Highway

Timing Plan: P.M. Peak



Lane Group	EBT	EBR	WBL	WBT	SBL	SBT
Lane Group Flow (vph)	569	405	428	1151	214	196
v/c Ratio	0.40	0.47	0.94	0.46	0.87	0.59
Control Delay	16.2	3.7	58.2	5.0	63.8	20.1
Queue Delay	0.0	0.0	0.0	0.0	0.0	0.0
Total Delay	16.2	3.7	58.2	5.0	63.8	20.1
Queue Length 50th (ft)	89	0	180	87	96	30
Queue Length 95th (ft)	128	49	#340	116	#190	81
Internal Link Dist (ft)	343			451		751
Turn Bay Length (ft)			250		420	
Base Capacity (vph)	1410	864	455	2522	247	330
Starvation Cap Reductn	0	0	0	0	0	0
Spillback Cap Reductn	0	0	0	0	0	0
Storage Cap Reductn	0	0	0	0	0	0
Reduced v/c Ratio	0.40	0.47	0.94	0.46	0.87	0.59

Intersection Summary

# 95th percentile volume exceeds capacity, queue may be longer.  
 Queue shown is maximum after two cycles.

Queues  
1: Old Redwood Hwy & Shiloh Road

Existing Project Alter. B Conditions  
Timing Plan: Saturday Midday Peak



Lane Group	EBL	EBT	EBR	WBT	WBR	NBL	NBT	NBR	SBL	SBT	SBR
Lane Group Flow (vph)	138	496	260	577	80	261	260	26	76	215	198
v/c Ratio	0.30	1.04	0.54	0.97	0.14	1.21	0.60	0.06	0.85	0.72	0.53
Control Delay	39.2	95.7	25.5	71.9	3.5	175.2	47.1	0.3	119.3	61.7	16.8
Queue Delay	0.0	0.0	0.0	0.0	0.0	0.0	0.0	0.0	0.0	0.0	0.0
Total Delay	39.2	95.7	25.5	71.9	3.5	175.2	47.1	0.3	119.3	61.7	16.8
Queue Length 50th (ft)	86	~410	91	435	0	~244	179	0	59	159	28
Queue Length 95th (ft)	153	#670	188	#683	18	#446	266	0	#163	242	99
Internal Link Dist (ft)		1709		528			668			695	
Turn Bay Length (ft)	375		140		50	200		98	130		93
Base Capacity (vph)	453	477	485	593	576	215	681	615	89	547	563
Starvation Cap Reductn	0	0	0	0	0	0	0	0	0	0	0
Spillback Cap Reductn	0	0	0	0	0	0	0	0	0	0	0
Storage Cap Reductn	0	0	0	0	0	0	0	0	0	0	0
Reduced v/c Ratio	0.30	1.04	0.54	0.97	0.14	1.21	0.38	0.04	0.85	0.39	0.35

Intersection Summary

~ Volume exceeds capacity, queue is theoretically infinite.

Queue shown is maximum after two cycles.

# 95th percentile volume exceeds capacity, queue may be longer.

Queue shown is maximum after two cycles.

Queues

2: Shiloh Road & Hembree Ln

Existing Project Alter. B Conditions

Timing Plan: Saturday Midday Peak



Lane Group	EBL	EBT	WBT	SBL	SBR
Lane Group Flow (vph)	662	752	895	176	637
v/c Ratio	0.66	0.57	0.71	0.60	0.73
Control Delay	26.3	6.6	21.9	39.6	17.1
Queue Delay	0.0	0.1	0.0	0.0	0.0
Total Delay	26.3	6.7	21.9	39.6	17.1
Queue Length 50th (ft)	132	132	169	73	160
Queue Length 95th (ft)	218	199	247	#172	362
Internal Link Dist (ft)		222	1709	301	
Turn Bay Length (ft)					
Base Capacity (vph)	1293	1725	2085	346	1004
Starvation Cap Reductn	0	142	0	0	0
Spillback Cap Reductn	0	0	0	0	0
Storage Cap Reductn	0	0	0	0	0
Reduced v/c Ratio	0.51	0.48	0.43	0.51	0.63

Intersection Summary

# 95th percentile volume exceeds capacity, queue may be longer.  
 Queue shown is maximum after two cycles.

Queues  
3: US 101 NB Off-Ramp & Shiloh Road

Existing Project Alter. B Conditions  
Timing Plan: Saturday Midday Peak

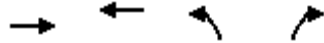

Lane Group	EBT	WBT	NBL	NBR
Lane Group Flow (vph)	589	1058	371	833
v/c Ratio	0.30	1.04	0.65	0.73
Control Delay	9.2	58.3	23.2	13.9
Queue Delay	0.0	0.0	0.0	0.0
Total Delay	9.2	58.3	23.2	13.9
Queue Length 50th (ft)	54	~385	114	81
Queue Length 95th (ft)	117	#788	187	141
Internal Link Dist (ft)	106	291	689	
Turn Bay Length (ft)				265
Base Capacity (vph)	1932	1017	908	1603
Starvation Cap Reductn	0	0	0	0
Spillback Cap Reductn	0	0	0	0
Storage Cap Reductn	0	0	0	0
Reduced v/c Ratio	0.30	1.04	0.41	0.52

Intersection Summary

- ~ Volume exceeds capacity, queue is theoretically infinite.  
Queue shown is maximum after two cycles.
- # 95th percentile volume exceeds capacity, queue may be longer.  
Queue shown is maximum after two cycles.

Queues  
4: Shiloh Road & US 101 SB Off-Ramp

Existing Project Alter. B Conditions  
Timing Plan: Saturday Midday Peak

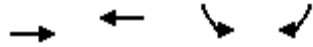

Lane Group	EBT	WBT	SBL	SBR
Lane Group Flow (vph)	307	571	471	222
v/c Ratio	0.39	0.73	0.68	0.29
Control Delay	9.9	16.3	20.2	3.5
Queue Delay	0.0	0.0	0.0	0.0
Total Delay	9.9	16.3	20.2	3.5
Queue Length 50th (ft)	49	109	92	0
Queue Length 95th (ft)	89	189	148	14
Internal Link Dist (ft)	145	226	406	
Turn Bay Length (ft)				275
Base Capacity (vph)	1863	1863	695	756
Starvation Cap Reductn	0	0	0	0
Spillback Cap Reductn	0	0	0	0
Storage Cap Reductn	0	0	0	0
Reduced v/c Ratio	0.16	0.31	0.68	0.29
<b>Intersection Summary</b>				

Queues  
6: Conde Lane & Shiloh Road

Existing Project Alter. B Conditions  
Timing Plan: Saturday Midday Peak

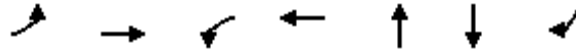

Lane Group	EBL	EBT	WBL	WBT	NBT	SBT	SBR
Lane Group Flow (vph)	30	400	10	692	12	253	36
v/c Ratio	0.07	0.29	0.02	0.52	0.02	0.46	0.06
Control Delay	19.3	10.1	19.7	10.7	0.1	21.3	10.3
Queue Delay	0.0	0.0	0.0	0.0	0.0	0.0	0.0
Total Delay	19.3	10.1	19.7	10.7	0.1	21.3	10.3
Queue Length 50th (ft)	4	21	1	35	0	35	3
Queue Length 95th (ft)	35	97	17	159	0	#187	24
Internal Link Dist (ft)		735		1001	338	442	
Turn Bay Length (ft)	90		127				40
Base Capacity (vph)	452	3258	401	3074	1444	552	1453
Starvation Cap Reductn	0	0	0	0	0	0	0
Spillback Cap Reductn	0	0	0	0	0	0	0
Storage Cap Reductn	0	0	0	0	0	0	0
Reduced v/c Ratio	0.07	0.12	0.02	0.23	0.01	0.46	0.02

Intersection Summary

# 95th percentile volume exceeds capacity, queue may be longer.  
Queue shown is maximum after two cycles.



Queues

Existing Project Alter. B Conditions

10: US 101 NB Off Ramp/Lakewood Drive & Old Redwood Highway Timing Plan: Saturday Midday Peak



Lane Group	EBL	EBT	WBT	NBL	NBT	SBL	SBR
Lane Group Flow (vph)	265	354	843	230	456	243	699
v/c Ratio	0.76	0.37	0.67	0.63	0.59	0.80	0.88
Control Delay	52.0	14.5	23.2	35.3	26.2	57.8	26.6
Queue Delay	0.0	0.0	0.0	0.0	0.0	0.0	0.0
Total Delay	52.0	14.5	23.2	35.3	26.2	57.8	26.6
Queue Length 50th (ft)	67	100	161	113	95	61	191
Queue Length 95th (ft)	#142	198	261	187	141	#134	338
Internal Link Dist (ft)		146	537		636		
Turn Bay Length (ft)	155			270		120	
Base Capacity (vph)	348	949	1256	591	1220	304	794
Starvation Cap Reductn	0	0	0	0	0	0	0
Spillback Cap Reductn	0	0	0	0	0	0	0
Storage Cap Reductn	0	0	0	0	0	0	0
Reduced v/c Ratio	0.76	0.37	0.67	0.39	0.37	0.80	0.88

Intersection Summary

# 95th percentile volume exceeds capacity, queue may be longer.  
 Queue shown is maximum after two cycles.

Queues

Existing Project Alter. B Conditions

12: US 101 SB On Ramp/US 101 SB Off Ramp & Old Redwood Highway Timing Plan: Saturday Midday Peak



























Lane Group	EBT	EBR	WBL	WBT	SBL	SBT
Lane Group Flow (vph)	498	379	446	748	194	182
v/c Ratio	0.36	0.45	0.94	0.29	0.81	0.61
Control Delay	16.1	3.8	55.6	3.9	56.6	25.6
Queue Delay	0.0	0.0	0.0	0.0	0.0	0.0
Total Delay	16.1	3.8	55.6	3.9	56.6	25.6
Queue Length 50th (ft)	77	0	186	47	86	41
Queue Length 95th (ft)	114	49	#354	67	#133	71
Internal Link Dist (ft)	343			451		751
Turn Bay Length (ft)			250		420	
Base Capacity (vph)	1381	837	480	2537	240	298
Starvation Cap Reductn	0	0	0	0	0	0
Spillback Cap Reductn	0	0	0	0	0	0
Storage Cap Reductn	0	0	0	0	0	0
Reduced v/c Ratio	0.36	0.45	0.93	0.29	0.81	0.61

Intersection Summary

# 95th percentile volume exceeds capacity, queue may be longer.  
 Queue shown is maximum after two cycles.

HCM 6th Signalized Intersection Summary  
1: Old Redwood Hwy & Shiloh Road

























Existing Project Alter. B Conditions Mitigations  
Timing Plan: A.M. PEAK

												
Movement	EBL	EBT	EBR	WBL	WBT	WBR	NBL	NBT	NBR	SBL	SBT	SBR
Lane Configurations												
Traffic Volume (veh/h)	108	274	104	22	171	26	92	125	34	35	234	169
Future Volume (veh/h)	108	274	104	22	171	26	92	125	34	35	234	169
Initial Q (Qb), veh	0	0	0	0	0	0	0	0	0	0	0	0
Ped-Bike Adj(A_pbT)	1.00		1.00	1.00		1.00	1.00		1.00	1.00		0.99
Parking Bus, Adj	1.00	1.00	1.00	1.00	1.00	1.00	1.00	1.00	1.00	1.00	1.00	1.00
Work Zone On Approach		No			No			No			No	
Adj Sat Flow, veh/h/ln	1870	1870	1870	1870	1870	1870	1870	1870	1870	1870	1870	1870
Adj Flow Rate, veh/h	133	338	128	25	192	29	99	134	37	41	275	199
Peak Hour Factor	0.81	0.81	0.81	0.89	0.89	0.89	0.93	0.93	0.93	0.85	0.85	0.85
Percent Heavy Veh, %	2	2	2	2	2	2	2	2	2	2	2	2
Cap, veh/h	441	463	392	268	281	239	306	393	333	159	394	329
Arrive On Green	0.25	0.25	0.25	0.15	0.15	0.15	0.09	0.21	0.21	0.09	0.21	0.21
Sat Flow, veh/h	1781	1870	1585	1781	1870	1585	3456	1870	1585	1781	1870	1564
Grp Volume(v), veh/h	133	338	128	25	192	29	99	134	37	41	275	199
Grp Sat Flow(s),veh/h/ln	1781	1870	1585	1781	1870	1585	1728	1870	1585	1781	1870	1564
Q Serve(g_s), s	3.4	9.3	3.7	0.7	5.4	0.9	1.5	3.4	1.1	1.2	7.6	6.5
Cycle Q Clear(g_c), s	3.4	9.3	3.7	0.7	5.4	0.9	1.5	3.4	1.1	1.2	7.6	6.5
Prop In Lane	1.00		1.00	1.00		1.00	1.00		1.00	1.00		1.00
Lane Grp Cap(c), veh/h	441	463	392	268	281	239	306	393	333	159	394	329
V/C Ratio(X)	0.30	0.73	0.33	0.09	0.68	0.12	0.32	0.34	0.11	0.26	0.70	0.60
Avail Cap(c_a), veh/h	969	1017	862	1207	1267	1074	894	1451	1230	191	1167	976
HCM Platoon Ratio	1.00	1.00	1.00	1.00	1.00	1.00	1.00	1.00	1.00	1.00	1.00	1.00
Upstream Filter(I)	1.00	1.00	1.00	1.00	1.00	1.00	1.00	1.00	1.00	1.00	1.00	1.00
Uniform Delay (d), s/veh	17.2	19.4	17.3	20.5	22.6	20.6	24.0	18.9	17.9	23.8	20.5	20.0
Incr Delay (d2), s/veh	0.4	2.2	0.5	0.1	2.9	0.2	0.6	0.5	0.1	0.9	2.2	1.8
Initial Q Delay(d3),s/veh	0.0	0.0	0.0	0.0	0.0	0.0	0.0	0.0	0.0	0.0	0.0	0.0
%ile BackOfQ(50%),veh/ln	1.3	3.8	1.2	0.3	2.3	0.3	0.6	1.3	0.3	0.5	3.1	2.2
Unsig. Movement Delay, s/veh												
LnGrp Delay(d),s/veh	17.5	21.6	17.8	20.7	25.5	20.8	24.6	19.4	18.1	24.7	22.7	21.8
LnGrp LOS	B	C	B	C	C	C	C	B	B	C	C	C
Approach Vol, veh/h		599			246			270			515	
Approach Delay, s/veh		19.9			24.4			21.1			22.5	
Approach LOS		B			C			C			C	
Timer - Assigned Phs		2	3	4		6	7	8				
Phs Duration (G+Y+Rc), s		18.4	8.5	16.3		12.9	8.5	16.3				
Change Period (Y+Rc), s		4.5	3.5	4.5		4.5	3.5	4.5				
Max Green Setting (Gmax), s		30.5	14.5	35.0		38.0	6.0	43.5				
Max Q Clear Time (g_c+I1), s		11.3	3.5	9.6		7.4	3.2	5.4				
Green Ext Time (p_c), s		2.6	0.2	2.2		1.2	0.0	0.8				
<b>Intersection Summary</b>												
HCM 6th Ctrl Delay				21.6								
HCM 6th LOS				C								

HCM 6th Signalized Intersection Summary  
1: Old Redwood Hwy & Shiloh Road

























Existing Project Alter. B Conditions Mitigations

Timing Plan: P.M. Peak

												
Movement	EBL	EBT	EBR	WBL	WBT	WBR	NBL	NBT	NBR	SBL	SBT	SBR
Lane Configurations												
Traffic Volume (veh/h)	241	356	223	37	332	49	198	345	21	59	242	146
Future Volume (veh/h)	241	356	223	37	332	49	198	345	21	59	242	146
Initial Q (Qb), veh	0	0	0	0	0	0	0	0	0	0	0	0
Ped-Bike Adj(A_pbT)	1.00		1.00	1.00		1.00	1.00		0.97	1.00		0.98
Parking Bus, Adj	1.00	1.00	1.00	1.00	1.00	1.00	1.00	1.00	1.00	1.00	1.00	1.00
Work Zone On Approach		No			No			No			No	
Adj Sat Flow, veh/h/ln	1870	1870	1870	1870	1870	1870	1870	1870	1870	1870	1870	1870
Adj Flow Rate, veh/h	248	367	230	41	365	54	213	371	23	63	260	157
Peak Hour Factor	0.97	0.97	0.97	0.91	0.91	0.91	0.93	0.93	0.93	0.93	0.93	0.93
Percent Heavy Veh, %	2	2	2	2	2	2	2	2	2	2	2	2
Cap, veh/h	441	463	392	426	447	378	308	456	376	109	404	337
Arrive On Green	0.25	0.25	0.25	0.24	0.24	0.24	0.09	0.24	0.24	0.06	0.22	0.22
Sat Flow, veh/h	1781	1870	1582	1781	1870	1582	3456	1870	1543	1781	1870	1559
Grp Volume(v), veh/h	248	367	230	41	365	54	213	371	23	63	260	157
Grp Sat Flow(s),veh/h/ln	1781	1870	1582	1781	1870	1582	1728	1870	1543	1781	1870	1559
Q Serve(g_s), s	9.9	15.0	10.5	1.5	15.1	2.2	4.9	15.3	0.9	2.8	10.3	7.2
Cycle Q Clear(g_c), s	9.9	15.0	10.5	1.5	15.1	2.2	4.9	15.3	0.9	2.8	10.3	7.2
Prop In Lane	1.00		1.00	1.00		1.00	1.00		1.00	1.00		1.00
Lane Grp Cap(c), veh/h	441	463	392	426	447	378	308	456	376	109	404	337
V/C Ratio(X)	0.56	0.79	0.59	0.10	0.82	0.14	0.69	0.81	0.06	0.58	0.64	0.47
Avail Cap(c_a), veh/h	665	698	591	829	870	736	613	996	822	131	801	668
HCM Platoon Ratio	1.00	1.00	1.00	1.00	1.00	1.00	1.00	1.00	1.00	1.00	1.00	1.00
Upstream Filter(I)	1.00	1.00	1.00	1.00	1.00	1.00	1.00	1.00	1.00	1.00	1.00	1.00
Uniform Delay (d), s/veh	26.9	28.8	27.1	24.2	29.4	24.5	36.1	29.1	23.7	37.3	29.2	27.9
Incr Delay (d2), s/veh	1.1	3.7	1.4	0.1	3.7	0.2	2.8	3.6	0.1	4.8	1.7	1.0
Initial Q Delay(d3),s/veh	0.0	0.0	0.0	0.0	0.0	0.0	0.0	0.0	0.0	0.0	0.0	0.0
%ile BackOfQ(50%),veh/ln	4.1	6.7	3.8	0.6	6.8	0.8	2.1	6.7	0.3	1.3	4.6	2.6
Unsig. Movement Delay, s/veh												
LnGrp Delay(d),s/veh	28.0	32.4	28.5	24.3	33.0	24.6	38.9	32.7	23.8	42.1	30.9	28.9
LnGrp LOS	C	C	C	C	C	C	D	C	C	D	C	C
Approach Vol, veh/h		845			460			607			480	
Approach Delay, s/veh		30.0			31.3			34.5			31.7	
Approach LOS		C			C			C			C	
Timer - Assigned Phs		2	3	4		6	7	8				
Phs Duration (G+Y+Rc), s		24.7	10.8	22.1		24.0	8.5	24.4				
Change Period (Y+Rc), s		4.5	3.5	4.5		4.5	3.5	4.5				
Max Green Setting (Gmax), s		30.5	14.5	35.0		38.0	6.0	43.5				
Max Q Clear Time (g_c+I1), s		17.0	6.9	12.3		17.1	4.8	17.3				
Green Ext Time (p_c), s		3.1	0.4	1.9		2.3	0.0	2.1				
<b>Intersection Summary</b>												
HCM 6th Ctrl Delay				31.8								
HCM 6th LOS				C								

HCM 6th Signalized Intersection Summary  
1: Old Redwood Hwy & Shiloh Road



















Existing Project Alter. B Conditions Mitigations  
Timing Plan: Saturday Midday Peak

												
Movement	EBL	EBT	EBR	WBL	WBT	WBR	NBL	NBT	NBR	SBL	SBT	SBR
Lane Configurations												
Traffic Volume (veh/h)	123	441	231	21	476	69	243	242	24	69	196	180
Future Volume (veh/h)	123	441	231	21	476	69	243	242	24	69	196	180
Initial Q (Qb), veh	0	0	0	0	0	0	0	0	0	0	0	0
Ped-Bike Adj(A_pbT)	1.00		0.97	1.00		1.00	1.00		0.98	1.00		0.98
Parking Bus, Adj	1.00	1.00	1.00	1.00	1.00	1.00	1.00	1.00	1.00	1.00	1.00	1.00
Work Zone On Approach		No			No			No			No	
Adj Sat Flow, veh/h/ln	1870	1870	1870	1870	1870	1870	1870	1870	1870	1870	1870	1870
Adj Flow Rate, veh/h	138	496	260	24	553	80	261	260	26	76	215	198
Peak Hour Factor	0.89	0.89	0.89	0.86	0.86	0.86	0.93	0.93	0.93	0.91	0.91	0.91
Percent Heavy Veh, %	2	2	2	2	2	2	2	2	2	2	2	2
Cap, veh/h	193	740	611	129	672	570	383	400	331	129	328	273
Arrive On Green	0.11	0.40	0.40	0.07	0.36	0.36	0.11	0.21	0.21	0.07	0.18	0.18
Sat Flow, veh/h	1781	1870	1544	1781	1870	1585	3456	1870	1551	1781	1870	1556
Grp Volume(v), veh/h	138	496	260	24	553	80	261	260	26	76	215	198
Grp Sat Flow(s),veh/h/ln	1781	1870	1544	1781	1870	1585	1728	1870	1551	1781	1870	1556
Q Serve(g_s), s	5.2	15.1	8.5	0.9	18.6	2.4	5.0	8.8	0.9	2.9	7.4	8.3
Cycle Q Clear(g_c), s	5.2	15.1	8.5	0.9	18.6	2.4	5.0	8.8	0.9	2.9	7.4	8.3
Prop In Lane	1.00		1.00	1.00		1.00	1.00		1.00	1.00		1.00
Lane Grp Cap(c), veh/h	193	740	611	129	672	570	383	400	331	129	328	273
V/C Ratio(X)	0.71	0.67	0.43	0.19	0.82	0.14	0.68	0.65	0.08	0.59	0.66	0.73
Avail Cap(c_a), veh/h	773	988	816	980	1204	1021	925	1196	992	240	947	788
HCM Platoon Ratio	1.00	1.00	1.00	1.00	1.00	1.00	1.00	1.00	1.00	1.00	1.00	1.00
Upstream Filter(I)	1.00	1.00	1.00	1.00	1.00	1.00	1.00	1.00	1.00	1.00	1.00	1.00
Uniform Delay (d), s/veh	29.8	17.2	15.2	30.1	20.1	14.9	29.5	24.8	21.7	31.1	26.6	26.9
Incr Delay (d2), s/veh	4.8	1.1	0.5	0.7	2.6	0.1	2.1	1.8	0.1	4.2	2.2	3.7
Initial Q Delay(d3),s/veh	0.0	0.0	0.0	0.0	0.0	0.0	0.0	0.0	0.0	0.0	0.0	0.0
%ile BackOfQ(50%),veh/ln	2.3	5.8	2.6	0.4	7.5	0.8	2.0	3.7	0.3	1.3	3.2	0.3
Unsig. Movement Delay, s/veh												
LnGrp Delay(d),s/veh	34.6	18.3	15.7	30.8	22.7	15.0	31.7	26.6	21.8	35.3	28.8	30.6
LnGrp LOS	C	B	B	C	C	B	C	C	C	D	C	C
Approach Vol, veh/h		894			657			547			489	
Approach Delay, s/veh		20.0			22.1			28.8			30.5	
Approach LOS		C			C			C			C	
Timer - Assigned Phs	1	2	3	4	5	6	7	8				
Phs Duration (G+Y+Rc), s	9.5	31.8	11.2	16.6	12.0	29.3	8.5	19.3				
Change Period (Y+Rc), s	4.5	4.5	3.5	4.5	4.5	4.5	3.5	4.5				
Max Green Setting (Gmax), s	38.0	36.5	18.5	35.0	30.0	44.5	9.3	44.2				
Max Q Clear Time (g_c+I1), s	2.9	17.1	7.0	10.3	7.2	20.6	4.9	10.8				
Green Ext Time (p_c), s	0.0	3.8	0.6	1.8	0.3	3.7	0.0	1.5				
<b>Intersection Summary</b>												
HCM 6th Ctrl Delay			24.4									
HCM 6th LOS			C									

HCM 6th Signalized Intersection Summary  
7: Driveway 1/Gridley Drive & Shiloh Road

Existing Project Alter. B Conditions Mitigations

Timing Plan: Saturday Midday Peak

												
Movement	EBL	EBT	EBR	WBL	WBT	WBR	NBL	NBT	NBR	SBL	SBT	SBR
Lane Configurations												
Traffic Volume (veh/h)	20	422	103	0	438	0	113	0	0	0	0	18
Future Volume (veh/h)	20	422	103	0	438	0	113	0	0	0	0	18
Initial Q (Qb), veh	0	0	0	0	0	0	0	0	0	0	0	0
Ped-Bike Adj(A_pbT)	1.00		0.99	1.00		1.00	1.00		1.00	1.00		1.00
Parking Bus, Adj	1.00	1.00	1.00	1.00	1.00	1.00	1.00	1.00	1.00	1.00	1.00	1.00
Work Zone On Approach		No			No			No			No	
Adj Sat Flow, veh/h/ln	1870	1870	1870	1870	1870	1870	1870	1870	1870	1870	1870	1870
Adj Flow Rate, veh/h	22	454	111	0	498	0	113	0	0	0	0	32
Peak Hour Factor	0.93	0.93	0.93	0.88	0.88	0.88	1.00	1.00	1.00	0.56	0.56	0.56
Percent Heavy Veh, %	2	2	2	2	2	2	2	2	2	2	2	2
Cap, veh/h	129	685	595	0	712	0	627	576	0	0	0	489
Arrive On Green	0.38	0.38	0.38	0.00	0.38	0.00	0.31	0.00	0.00	0.00	0.00	0.31
Sat Flow, veh/h	33	1801	1564	0	1870	0	1377	1870	0	0	0	1585
Grp Volume(v), veh/h	476	0	111	0	498	0	113	0	0	0	0	32
Grp Sat Flow(s),veh/h/ln	1835	0	1564	0	1870	0	1377	1870	0	0	0	1585
Q Serve(g_s), s	0.0	0.0	1.5	0.0	7.3	0.0	2.0	0.0	0.0	0.0	0.0	0.5
Cycle Q Clear(g_c), s	6.9	0.0	1.5	0.0	7.3	0.0	2.5	0.0	0.0	0.0	0.0	0.5
Prop In Lane	0.05		1.00	0.00		0.00	1.00		0.00	0.00		1.00
Lane Grp Cap(c), veh/h	814	0	595	0	712	0	627	576	0	0	0	489
V/C Ratio(X)	0.58	0.00	0.19	0.00	0.70	0.00	0.18	0.00	0.00	0.00	0.00	0.07
Avail Cap(c_a), veh/h	1597	0	1282	0	1533	0	1191	1343	0	0	0	1138
HCM Platoon Ratio	1.00	1.00	1.00	1.00	1.00	1.00	1.00	1.00	1.00	1.00	1.00	1.00
Upstream Filter(I)	1.00	0.00	1.00	0.00	1.00	0.00	1.00	0.00	0.00	0.00	0.00	1.00
Uniform Delay (d), s/veh	8.4	0.0	6.7	0.0	8.5	0.0	8.8	0.0	0.0	0.0	0.0	7.9
Incr Delay (d2), s/veh	0.7	0.0	0.1	0.0	1.3	0.0	0.1	0.0	0.0	0.0	0.0	0.1
Initial Q Delay(d3),s/veh	0.0	0.0	0.0	0.0	0.0	0.0	0.0	0.0	0.0	0.0	0.0	0.0
%ile BackOfQ(50%),veh/ln	1.6	0.0	0.3	0.0	1.8	0.0	0.5	0.0	0.0	0.0	0.0	0.1
Unsig. Movement Delay, s/veh												
LnGrp Delay(d),s/veh	9.0	0.0	6.9	0.0	9.7	0.0	8.9	0.0	0.0	0.0	0.0	8.0
LnGrp LOS	A	A	A	A	A	A	A	A	A	A	A	A
Approach Vol, veh/h		587			498			113				32
Approach Delay, s/veh		8.6			9.7			8.9				8.0
Approach LOS		A			A			A				A
Timer - Assigned Phs		2		4		6		8				
Phs Duration (G+Y+Rc), s		14.7		17.6		14.7		17.6				
Change Period (Y+Rc), s		* 4.7		5.4		* 4.7		5.4				
Max Green Setting (Gmax), s		* 23		26.6		* 23		26.6				
Max Q Clear Time (g_c+I1), s		4.5		8.9		2.5		9.3				
Green Ext Time (p_c), s		0.3		3.0		0.1		2.7				

Intersection Summary

HCM 6th Ctrl Delay	9.1
HCM 6th LOS	A

Notes

\* HCM 6th computational engine requires equal clearance times for the phases crossing the barrier.

Queues  
1: Old Redwood Hwy & Shiloh Road

Existing Project Alter. B Conditions  
Timing Plan: A.M. PEAK



Lane Group	EBL	EBT	EBR	WBL	WBT	WBR	NBL	NBT	NBR	SBL	SBT	SBR
Lane Group Flow (vph)	133	338	128	25	192	29	99	134	37	41	275	199
v/c Ratio	0.27	0.66	0.25	0.07	0.55	0.08	0.27	0.25	0.07	0.29	0.62	0.42
Control Delay	28.1	35.2	10.0	32.9	39.8	0.4	41.5	26.7	1.0	49.2	37.2	14.2
Queue Delay	0.0	0.0	0.0	0.0	0.0	0.0	0.0	0.0	0.0	0.0	0.0	0.0
Total Delay	28.1	35.2	10.0	32.9	39.8	0.4	41.5	26.7	1.0	49.2	37.2	14.2
Queue Length 50th (ft)	53	151	9	11	90	0	24	55	0	20	127	26
Queue Length 95th (ft)	112	270	46	37	191	0	60	121	4	61	237	86
Internal Link Dist (ft)		1709			528			668			695	
Turn Bay Length (ft)	375		150	200		50	200		98	190		105
Base Capacity (vph)	733	772	717	914	962	868	676	1101	967	144	886	814
Starvation Cap Reductn	0	0	0	0	0	0	0	0	0	0	0	0
Spillback Cap Reductn	0	0	0	0	0	0	0	0	0	0	0	0
Storage Cap Reductn	0	0	0	0	0	0	0	0	0	0	0	0
Reduced v/c Ratio	0.18	0.44	0.18	0.03	0.20	0.03	0.15	0.12	0.04	0.28	0.31	0.24

Intersection Summary

Queues  
7: Driveway 1/Gridley Drive & Shiloh Road

Existing Project Alter. B Conditions  
Timing Plan: A.M. PEAK

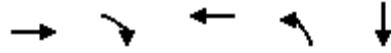

Lane Group	EBT	EBR	WBT	NBL	SBT
Lane Group Flow (vph)	323	52	187	33	24
v/c Ratio	0.47	0.08	0.27	0.09	0.05
Control Delay	8.4	2.3	6.4	8.8	3.5
Queue Delay	0.0	0.0	0.0	0.0	0.0
Total Delay	8.4	2.3	6.4	8.8	3.5
Queue Length 50th (ft)	25	0	13	3	0
Queue Length 95th (ft)	57	8	31	14	4
Internal Link Dist (ft)	528		2066		635
Turn Bay Length (ft)		150			
Base Capacity (vph)	1355	1163	1370	1016	1190
Starvation Cap Reductn	0	0	0	0	0
Spillback Cap Reductn	0	0	0	0	0
Storage Cap Reductn	0	0	0	0	0
Reduced v/c Ratio	0.24	0.04	0.14	0.03	0.02
<b>Intersection Summary</b>					



Queues  
1: Old Redwood Hwy & Shiloh Road

E+P Alternative B\_Mitigations  
Timing Plan: P.M. Peak



Lane Group	EBL	EBT	EBR	WBL	WBT	WBR	NBL	NBT	NBR	SBL	SBT	SBR
Lane Group Flow (vph)	248	367	230	41	365	54	213	371	23	63	260	157
v/c Ratio	0.55	0.77	0.45	0.09	0.78	0.12	0.54	0.76	0.05	0.59	0.68	0.38
Control Delay	41.9	50.6	16.8	33.2	50.0	0.5	52.8	48.1	0.2	77.1	50.0	16.2
Queue Delay	0.0	0.0	0.0	0.0	0.0	0.0	0.0	0.0	0.0	0.0	0.0	0.0
Total Delay	41.9	50.6	16.8	33.2	50.0	0.5	52.8	48.1	0.2	77.1	50.0	16.2
Queue Length 50th (ft)	140	223	41	22	234	0	71	237	0	43	168	25
Queue Length 95th (ft)	285	#469	137	55	392	0	133	386	0	#139	289	92
Internal Link Dist (ft)		1709			528			668			695	
Turn Bay Length (ft)	375		150	200		50	200		98	190		105
Base Capacity (vph)	543	572	590	677	712	657	501	816	720	106	656	622
Starvation Cap Reductn	0	0	0	0	0	0	0	0	0	0	0	0
Spillback Cap Reductn	0	0	0	0	0	0	0	0	0	0	0	0
Storage Cap Reductn	0	0	0	0	0	0	0	0	0	0	0	0
Reduced v/c Ratio	0.46	0.64	0.39	0.06	0.51	0.08	0.43	0.45	0.03	0.59	0.40	0.25

Intersection Summary

# 95th percentile volume exceeds capacity, queue may be longer.  
Queue shown is maximum after two cycles.

Queues  
7: Driveway 1/Gridley Drive & Shiloh Road

E+P Alternative B\_Mitigations  
Timing Plan: P.M. Peak

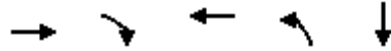

Lane Group	EBT	EBR	WBT	NBL	SBT
Lane Group Flow (vph)	375	81	494	71	24
v/c Ratio	0.48	0.11	0.61	0.21	0.04
Control Delay	8.2	2.1	10.1	11.6	0.1
Queue Delay	0.0	0.0	0.0	0.0	0.0
Total Delay	8.2	2.1	10.1	11.6	0.1
Queue Length 50th (ft)	33	0	47	8	0
Queue Length 95th (ft)	80	11	73	31	0
Internal Link Dist (ft)	528		2066		635
Turn Bay Length (ft)		150			
Base Capacity (vph)	1224	1089	1267	940	1165
Starvation Cap Reductn	0	0	0	0	0
Spillback Cap Reductn	0	0	0	0	0
Storage Cap Reductn	0	0	0	0	0
Reduced v/c Ratio	0.31	0.07	0.39	0.08	0.02
<b>Intersection Summary</b>					

Queues  
1: Old Redwood Hwy & Shiloh Road

E+P Alternative B\_Mitigations  
Timing Plan: Saturday Midday Peak

























Lane Group	EBL	EBT	EBR	WBL	WBT	WBR	NBL	NBT	NBR	SBL	SBT	SBR
Lane Group Flow (vph)	138	496	260	24	553	80	261	260	26	76	215	198
v/c Ratio	0.58	0.53	0.31	0.20	0.77	0.12	0.57	0.56	0.06	0.50	0.66	0.49
Control Delay	54.9	23.0	10.3	55.6	38.1	4.0	49.8	41.6	0.2	62.8	52.0	15.7
Queue Delay	0.0	0.0	0.0	0.0	0.2	0.0	0.0	0.0	0.0	0.0	0.0	0.0
Total Delay	54.9	23.0	10.3	55.6	38.3	4.0	49.8	41.6	0.2	62.8	52.0	15.7
Queue Length 50th (ft)	89	232	48	16	308	0	86	162	0	50	138	24
Queue Length 95th (ft)	171	420	127	47	#543	21	149	266	0	#125	244	99
Internal Link Dist (ft)		1709			528			668			695	
Turn Bay Length (ft)	375		150	200		50	200		98	190		105
Base Capacity (vph)	532	933	842	674	831	761	637	826	745	165	654	648
Starvation Cap Reductn	0	0	0	0	31	0	0	0	0	0	0	0
Spillback Cap Reductn	0	0	0	0	0	0	0	0	0	0	0	0
Storage Cap Reductn	0	0	0	0	0	0	0	0	0	0	0	0
Reduced v/c Ratio	0.26	0.53	0.31	0.04	0.69	0.11	0.41	0.31	0.03	0.46	0.33	0.31

Intersection Summary

# 95th percentile volume exceeds capacity, queue may be longer.  
Queue shown is maximum after two cycles.

Lanes, Volumes, Timings  
1: Old Redwood Hwy & Shiloh Road

Existing Project Alter. B Conditions  
Timing Plan: A.M. PEAK

												
Lane Group	EBL	EBT	EBR	WBL	WBT	WBR	NBL	NBT	NBR	SBL	SBT	SBR
Lane Configurations												
Traffic Volume (vph)	108	274	104	22	171	26	92	125	34	35	234	169
Future Volume (vph)	108	274	104	22	171	26	92	125	34	35	234	169
Ideal Flow (vphpl)	1900	1900	1900	1900	1900	1900	1900	1900	1900	1900	1900	1900
Storage Length (ft)	375		140	0		50	200		98	130		93
Storage Lanes	1		1	0		1	1		1	1		1
Taper Length (ft)	50			25			60			93		
Lane Util. Factor	1.00	1.00	1.00	1.00	1.00	1.00	1.00	1.00	1.00	1.00	1.00	1.00
Ped Bike Factor												0.98
Frt			0.850			0.850			0.850			0.850
Flt Protected	0.950				0.994		0.950			0.950		
Satd. Flow (prot)	1770	1863	1583	0	1852	1583	1770	1863	1583	1770	1863	1583
Flt Permitted	0.950				0.994		0.950			0.950		
Satd. Flow (perm)	1770	1863	1583	0	1852	1583	1770	1863	1583	1770	1863	1549
Right Turn on Red			Yes			Yes			Yes			Yes
Satd. Flow (RTOR)			105			105			77			123
Link Speed (mph)		40			40			45			40	
Link Distance (ft)		1789			608			748			775	
Travel Time (s)		30.5			10.4			11.3			13.2	
Confl. Bikes (#/hr)												1
Peak Hour Factor	0.81	0.81	0.81	0.89	0.89	0.89	0.93	0.93	0.93	0.85	0.85	0.85
Adj. Flow (vph)	133	338	128	25	192	29	99	134	37	41	275	199
Shared Lane Traffic (%)												
Lane Group Flow (vph)	133	338	128	0	217	29	99	134	37	41	275	199
Enter Blocked Intersection	No	No	No	No	No	No	No	No	No	No	No	No
Lane Alignment	Left	Left	Right	Left	Left	Right	Left	Left	Right	Left	Left	Right
Median Width(ft)		12			12			12			12	
Link Offset(ft)		0			0			0			0	
Crosswalk Width(ft)		16			16			16			16	
Two way Left Turn Lane												
Headway Factor	1.00	1.00	1.00	1.00	1.00	1.00	1.00	1.00	1.00	1.00	1.00	1.00
Turning Speed (mph)	15		9	15		9	15		9	15		9
Number of Detectors	1	2	1	1	2	1	1	2	1	1	2	1
Detector Template	Left	Thru	Right	Left	Thru	Right	Left	Thru	Right	Left	Thru	Right
Leading Detector (ft)	20	100	20	20	100	20	20	100	20	20	100	20
Trailing Detector (ft)	0	0	0	0	0	0	0	0	0	0	0	0
Detector 1 Position(ft)	0	0	0	0	0	0	0	0	0	0	0	0
Detector 1 Size(ft)	20	6	20	20	6	20	20	6	20	20	6	20
Detector 1 Type	Cl+Ex	Cl+Ex	Cl+Ex	Cl+Ex	Cl+Ex	Cl+Ex	Cl+Ex	Cl+Ex	Cl+Ex	Cl+Ex	Cl+Ex	Cl+Ex
Detector 1 Channel												
Detector 1 Extend (s)	0.0	0.0	0.0	0.0	0.0	0.0	0.0	0.0	0.0	0.0	0.0	0.0
Detector 1 Queue (s)	0.0	0.0	0.0	0.0	0.0	0.0	0.0	0.0	0.0	0.0	0.0	0.0
Detector 1 Delay (s)	0.0	0.0	0.0	0.0	0.0	0.0	0.0	0.0	0.0	0.0	0.0	0.0
Detector 2 Position(ft)		94			94			94			94	
Detector 2 Size(ft)		6			6			6			6	
Detector 2 Type		Cl+Ex			Cl+Ex			Cl+Ex			Cl+Ex	
Detector 2 Channel												
Detector 2 Extend (s)		0.0			0.0			0.0			0.0	
Turn Type	Split	NA	Perm	Split	NA	Perm	Prot	NA	Perm	Prot	NA	Perm

Lanes, Volumes, Timings  
1: Old Redwood Hwy & Shiloh Road

Existing Project Alter. B Conditions

Timing Plan: A.M. PEAK

Lane Group	EBL	EBT	EBR	WBL	WBT	WBR	NBL	NBT	NBR	SBL	SBT	SBR
Protected Phases	2	2		6	6		3	8		7	4	
Permitted Phases			2			6			8			4
Detector Phase	2	2	2	6	6	6	3	8	8	7	4	4
Switch Phase												
Minimum Initial (s)	5.0	5.0	5.0	5.0	5.0	5.0	5.0	5.0	5.0	5.0	5.0	5.0
Minimum Split (s)	34.5	34.5	34.5	42.5	42.5	42.5	8.5	46.5	46.5	8.5	39.5	39.5
Total Split (s)	35.0	35.0	35.0	42.5	42.5	42.5	18.0	48.0	48.0	9.5	39.5	39.5
Total Split (%)	25.9%	25.9%	25.9%	31.5%	31.5%	31.5%	13.3%	35.6%	35.6%	7.0%	29.3%	29.3%
Maximum Green (s)	30.5	30.5	30.5	38.0	38.0	38.0	14.5	43.5	43.5	6.0	35.0	35.0
Yellow Time (s)	3.5	3.5	3.5	3.5	3.5	3.5	3.0	3.5	3.5	3.0	3.5	3.5
All-Red Time (s)	1.0	1.0	1.0	1.0	1.0	1.0	0.5	1.0	1.0	0.5	1.0	1.0
Lost Time Adjust (s)	0.0	0.0	0.0		0.0	0.0	0.0	0.0	0.0	0.0	0.0	0.0
Total Lost Time (s)	4.5	4.5	4.5		4.5	4.5	3.5	4.5	4.5	3.5	4.5	4.5
Lead/Lag	Lead	Lead	Lead	Lag	Lag	Lag	Lead	Lag	Lag	Lead	Lag	Lag
Lead-Lag Optimize?	Yes	Yes	Yes	Yes	Yes	Yes	Yes	Yes	Yes	Yes	Yes	Yes
Vehicle Extension (s)	3.0	3.0	3.0	3.0	3.0	3.0	3.0	3.0	3.0	3.0	3.0	3.0
Recall Mode	None	None	None	None	None	None	None	None	None	None	None	None
Walk Time (s)	7.0	7.0	7.0	7.0	7.0	7.0		7.0	7.0		7.0	7.0
Flash Don't Walk (s)	23.0	23.0	23.0	31.0	31.0	31.0		35.0	35.0		28.0	28.0
Pedestrian Calls (#/hr)	0	0	0	0	0	0		0	0		0	0
Act Effct Green (s)	23.1	23.1	23.1		17.1	17.1	10.9	26.3	26.3	6.4	20.0	20.0
Actuated g/C Ratio	0.27	0.27	0.27		0.20	0.20	0.13	0.31	0.31	0.07	0.23	0.23
v/c Ratio	0.28	0.68	0.26		0.59	0.07	0.44	0.24	0.07	0.31	0.64	0.44
Control Delay (s/veh)	31.3	39.3	11.0		42.8	0.3	48.4	26.9	0.7	54.0	40.7	17.3
Queue Delay	0.0	0.0	0.0		0.0	0.0	0.0	0.0	0.0	0.0	0.0	0.0
Total Delay (s/veh)	31.3	39.3	11.0		42.8	0.3	48.4	26.9	0.7	54.0	40.7	17.3
LOS	C	D	B		D	A	D	C	A	D	D	B
Approach Delay (s/veh)		31.5			37.8			31.2			32.7	
Approach LOS		C			D			C			C	

Intersection Summary

Area Type:	Other
Cycle Length:	135
Actuated Cycle Length:	86.2
Natural Cycle:	135
Control Type:	Actuated-Uncoordinated
Maximum v/c Ratio:	0.68
Intersection Signal Delay (s/veh):	32.8
Intersection LOS:	C
Intersection Capacity Utilization:	56.6%
ICU Level of Service:	B
Analysis Period (min):	15

Splits and Phases: 1: Old Redwood Hwy & Shiloh Road

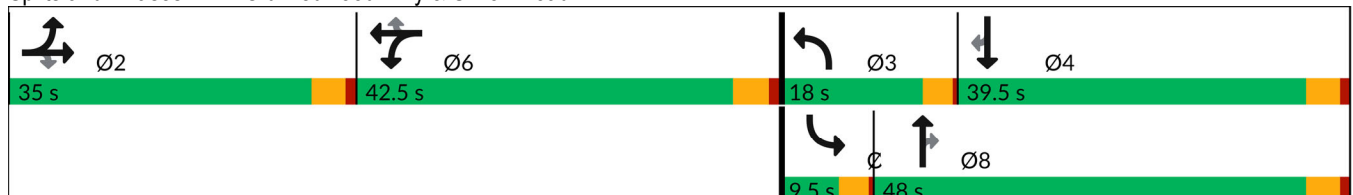

Lanes, Volumes, Timings  
2: Shiloh Road & Hembree Ln

Existing Project Alter. B Conditions  
Timing Plan: A.M. PEAK

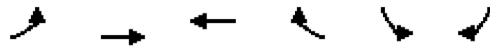

Lane Group	EBL	EBT	WBT	WBR	SBL	SBR
Lane Configurations						
Traffic Volume (vph)	305	434	392	68	71	361
Future Volume (vph)	305	434	392	68	71	361
Ideal Flow (vphpl)	1900	1900	1900	1900	1900	1900
Storage Length (ft)	0			130	0	0
Storage Lanes	2			1	1	1
Taper Length (ft)	25				25	
Lane Util. Factor	0.97	1.00	0.95	0.95	1.00	1.00
Frt			0.978			0.850
Flt Protected	0.950				0.950	
Satd. Flow (prot)	3433	1863	3461	0	1770	1583
Flt Permitted	0.950				0.950	
Satd. Flow (perm)	3433	1863	3461	0	1770	1583
Right Turn on Red				Yes		Yes
Satd. Flow (RTOR)			28			336
Link Speed (mph)		40	40		35	
Link Distance (ft)		302	1789		381	
Travel Time (s)		5.1	30.5		7.4	
Peak Hour Factor	0.88	0.88	0.97	0.97	0.94	0.94
Adj. Flow (vph)	347	493	404	70	76	384
Shared Lane Traffic (%)						
Lane Group Flow (vph)	347	493	474	0	76	384
Enter Blocked Intersection	No	No	No	No	No	No
Lane Alignment	Left	Left	Left	Right	Left	Right
Median Width(ft)		24	24		12	
Link Offset(ft)		0	0		0	
Crosswalk Width(ft)		16	16		16	
Two way Left Turn Lane						
Headway Factor	1.00	1.00	1.00	1.00	1.00	1.00
Turning Speed (mph)	15			9	15	9
Number of Detectors	1	2	2		1	1
Detector Template	Left	Thru	Thru		Left	Right
Leading Detector (ft)	20	100	100		20	20
Trailing Detector (ft)	0	0	0		0	0
Detector 1 Position(ft)	0	0	0		0	0
Detector 1 Size(ft)	20	6	6		20	20
Detector 1 Type	Cl+Ex	Cl+Ex	Cl+Ex		Cl+Ex	Cl+Ex
Detector 1 Channel						
Detector 1 Extend (s)	0.0	0.0	0.0		0.0	0.0
Detector 1 Queue (s)	0.0	0.0	0.0		0.0	0.0
Detector 1 Delay (s)	0.0	0.0	0.0		0.0	0.0
Detector 2 Position(ft)		94	94			
Detector 2 Size(ft)		6	6			
Detector 2 Type		Cl+Ex	Cl+Ex			
Detector 2 Channel						
Detector 2 Extend (s)		0.0	0.0			
Turn Type	Prot	NA	NA		Perm	pm+ov
Protected Phases	5	2	6			5
Permitted Phases					4	4 5

Lanes, Volumes, Timings  
2: Shiloh Road & Hembree Ln

Existing Project Alter. B Conditions  
Timing Plan: A.M. PEAK

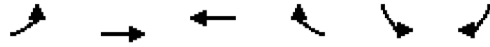

Lane Group	EBL	EBT	WBT	WBR	SBL	SBR
Detector Phase	5	2	6		4	5
Switch Phase						
Minimum Initial (s)	3.0	5.0	5.0		5.0	3.0
Minimum Split (s)	7.0	9.0	43.0		9.0	7.0
Total Split (s)	29.0	73.0	44.0		17.0	29.0
Total Split (%)	32.2%	81.1%	48.9%		18.9%	32.2%
Maximum Green (s)	25.0	69.0	40.0		13.0	25.0
Yellow Time (s)	3.0	3.0	3.0		3.0	3.0
All-Red Time (s)	1.0	1.0	1.0		1.0	1.0
Lost Time Adjust (s)	0.0	0.0	0.0		0.0	0.0
Total Lost Time (s)	4.0	4.0	4.0		4.0	4.0
Lead/Lag	Lead		Lag			Lead
Lead-Lag Optimize?	Yes		Yes			Yes
Vehicle Extension (s)	3.0	3.0	3.0		3.0	3.0
Recall Mode	None	None	None		None	None
Walk Time (s)			7.0			
Flash Don't Walk (s)			32.0			
Pedestrian Calls (#/hr)			0			
Act Effct Green (s)	10.8	29.8	11.9		7.9	16.9
Actuated g/C Ratio	0.29	0.79	0.31		0.21	0.45
v/c Ratio	0.35	0.34	0.43		0.21	0.43
Control Delay (s/veh)	13.9	3.9	12.7		17.9	3.0
Queue Delay	0.0	0.0	0.0		0.0	0.0
Total Delay (s/veh)	13.9	3.9	12.7		17.9	3.0
LOS	B	A	B		B	A
Approach Delay (s/veh)		8.0	12.7		5.5	
Approach LOS		A	B		A	

Intersection Summary

Area Type:	Other
Cycle Length:	90
Actuated Cycle Length:	37.8
Natural Cycle:	60
Control Type:	Actuated-Uncoordinated
Maximum v/c Ratio:	0.43
Intersection Signal Delay (s/veh):	8.6
Intersection LOS:	A
Intersection Capacity Utilization:	42.0%
ICU Level of Service:	A
Analysis Period (min):	15

Splits and Phases: 2: Shiloh Road & Hembree Ln



Lanes, Volumes, Timings  
 3: US 101 NB Off-Ramp & Shiloh Road

Existing Project Alter. B Conditions  
 Timing Plan: A.M. PEAK



Lane Group	EBT	EBR	WBL	WBT	NBL	NBR
Lane Configurations	↑↑			↑	↘	↗↗
Traffic Volume (vph)	301	0	0	581	432	451
Future Volume (vph)	301	0	0	581	432	451
Ideal Flow (vphpl)	1900	1900	1900	1900	1900	1900
Storage Length (ft)		0	0		0	265
Storage Lanes		0	0		1	2
Taper Length (ft)			25		25	
Lane Util. Factor	0.95	1.00	1.00	1.00	1.00	0.88
Frt						0.850
Flt Protected					0.950	
Satd. Flow (prot)	3539	0	0	1863	1770	2787
Flt Permitted					0.950	
Satd. Flow (perm)	3539	0	0	1863	1770	2787
Right Turn on Red		Yes				Yes
Satd. Flow (RTOR)						593
Link Speed (mph)	40			40	30	
Link Distance (ft)	186			371	769	
Travel Time (s)	3.2			6.3	17.5	
Peak Hour Factor	0.91	0.91	0.90	0.90	0.76	0.76
Adj. Flow (vph)	331	0	0	646	568	593
Shared Lane Traffic (%)						
Lane Group Flow (vph)	331	0	0	646	568	593
Enter Blocked Intersection	No	No	No	No	No	No
Lane Alignment	Left	Right	Left	Left	Left	Right
Median Width(ft)	0			0	12	
Link Offset(ft)	0			0	0	
Crosswalk Width(ft)	16			16	16	
Two way Left Turn Lane						
Headway Factor	1.00	1.00	1.00	1.00	1.00	1.00
Turning Speed (mph)		9	15		15	9
Number of Detectors	2			2	1	1
Detector Template	Thru			Thru	Left	Right
Leading Detector (ft)	100			100	20	20
Trailing Detector (ft)	0			0	0	0
Detector 1 Position(ft)	0			0	0	0
Detector 1 Size(ft)	6			6	20	20
Detector 1 Type	Cl+Ex			Cl+Ex	Cl+Ex	Cl+Ex
Detector 1 Channel						
Detector 1 Extend (s)	0.0			0.0	0.0	0.0
Detector 1 Queue (s)	0.0			0.0	0.0	0.0
Detector 1 Delay (s)	0.0			0.0	0.0	0.0
Detector 2 Position(ft)	94			94		
Detector 2 Size(ft)	6			6		
Detector 2 Type	Cl+Ex			Cl+Ex		
Detector 2 Channel						
Detector 2 Extend (s)	0.0			0.0		
Turn Type	NA			NA	Prot	Perm
Protected Phases	2			6	8	
Permitted Phases						8



Lanes, Volumes, Timings  
 3: US 101 NB Off-Ramp & Shiloh Road

Existing Project Alter. B Conditions  
 Timing Plan: A.M. PEAK

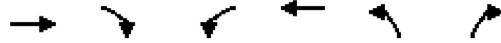

Lane Group	EBT	EBR	WBL	WBT	NBL	NBR
Detector Phase	2			6	8	8
Switch Phase						
Minimum Initial (s)	5.0			5.0	5.0	5.0
Minimum Split (s)	9.0			9.0	9.0	9.0
Total Split (s)	37.0			37.0	35.0	35.0
Total Split (%)	51.4%			51.4%	48.6%	48.6%
Maximum Green (s)	33.0			33.0	31.0	31.0
Yellow Time (s)	3.0			3.0	3.0	3.0
All-Red Time (s)	1.0			1.0	1.0	1.0
Lost Time Adjust (s)	0.0			0.0	0.0	0.0
Total Lost Time (s)	4.0			4.0	4.0	4.0
Lead/Lag						
Lead-Lag Optimize?						
Vehicle Extension (s)	3.0			3.0	3.0	3.0
Recall Mode	None			None	None	None
Act Effect Green (s)	25.3			25.3	24.1	24.1
Actuated g/C Ratio	0.44			0.44	0.42	0.42
v/c Ratio	0.21			0.80	0.77	0.39
Control Delay (s/veh)	11.2			23.7	24.1	2.2
Queue Delay	0.0			0.0	0.0	0.0
Total Delay (s/veh)	11.2			23.7	24.1	2.2
LOS	B			C	C	A
Approach Delay (s/veh)	11.2			23.7	12.9	
Approach LOS	B			C	B	

Intersection Summary

Area Type:	Other
Cycle Length:	72
Actuated Cycle Length:	58
Natural Cycle:	55
Control Type:	Actuated-Uncoordinated
Maximum v/c Ratio:	0.80
Intersection Signal Delay (s/veh):	15.9
Intersection LOS:	B
Intersection Capacity Utilization:	88.8%
ICU Level of Service:	E
Analysis Period (min):	15

Splits and Phases: 3: US 101 NB Off-Ramp & Shiloh Road

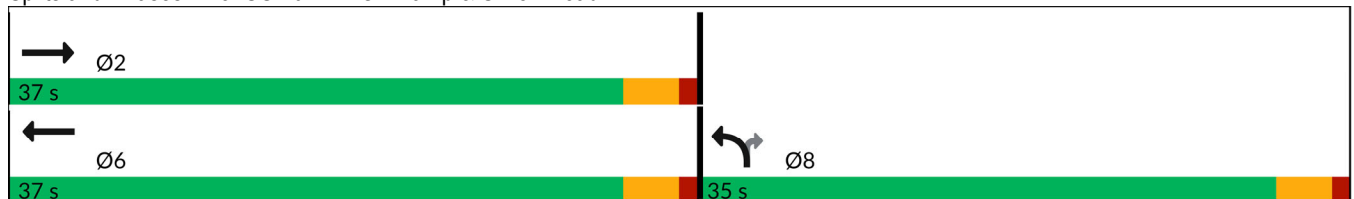

Lanes, Volumes, Timings  
4: Shiloh Road & US 101 SB Off-Ramp

Existing Project Alter. B Conditions  
Timing Plan: A.M. PEAK

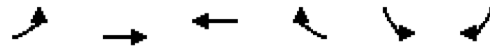

Lane Group	EBL	EBT	WBT	WBR	SBL	SBR
Lane Configurations		↑	↑		↘	↗
Traffic Volume (vph)	0	240	594	0	149	138
Future Volume (vph)	0	240	594	0	149	138
Ideal Flow (vphpl)	1900	1900	1900	1900	1900	1900
Storage Length (ft)	0			0	0	275
Storage Lanes	0			0	1	1
Taper Length (ft)	25				25	
Lane Util. Factor	1.00	1.00	1.00	1.00	1.00	1.00
Frt						0.850
Flt Protected					0.950	
Satd. Flow (prot)	0	1863	1863	0	1770	1583
Flt Permitted					0.950	
Satd. Flow (perm)	0	1863	1863	0	1770	1583
Right Turn on Red				Yes		Yes
Satd. Flow (RTOR)						150
Link Speed (mph)		40	40		30	
Link Distance (ft)		225	306		486	
Travel Time (s)		3.8	5.2		11.0	
Peak Hour Factor	0.93	0.93	0.91	0.91	0.92	0.92
Adj. Flow (vph)	0	258	653	0	162	150
Shared Lane Traffic (%)						
Lane Group Flow (vph)	0	258	653	0	162	150
Enter Blocked Intersection	No	No	No	No	No	No
Lane Alignment	Left	Left	Left	Right	Left	Right
Median Width(ft)		4	0		12	
Link Offset(ft)		0	0		0	
Crosswalk Width(ft)		16	16		16	
Two way Left Turn Lane						
Headway Factor	1.00	1.00	1.00	1.00	1.00	1.00
Turning Speed (mph)	15			9	15	9
Number of Detectors		2	2		1	1
Detector Template		Thru	Thru		Left	Right
Leading Detector (ft)		100	100		20	20
Trailing Detector (ft)		0	0		0	0
Detector 1 Position(ft)		0	0		0	0
Detector 1 Size(ft)		6	6		20	20
Detector 1 Type		Cl+Ex	Cl+Ex		Cl+Ex	Cl+Ex
Detector 1 Channel						
Detector 1 Extend (s)		0.0	0.0		0.0	0.0
Detector 1 Queue (s)		0.0	0.0		0.0	0.0
Detector 1 Delay (s)		0.0	0.0		0.0	0.0
Detector 2 Position(ft)		94	94			
Detector 2 Size(ft)		6	6			
Detector 2 Type		Cl+Ex	Cl+Ex			
Detector 2 Channel						
Detector 2 Extend (s)		0.0	0.0			
Turn Type		NA	NA		Perm	Perm
Protected Phases		2	6			
Permitted Phases					4	4

Lanes, Volumes, Timings  
4: Shiloh Road & US 101 SB Off-Ramp

Existing Project Alter. B Conditions  
Timing Plan: A.M. PEAK



Lane Group	EBL	EBT	WBT	WBR	SBL	SBR
Detector Phase		2	6		4	4
Switch Phase						
Minimum Initial (s)		5.0	5.0		5.0	5.0
Minimum Split (s)		9.0	38.0		9.0	9.0
Total Split (s)		69.0	69.0		21.0	21.0
Total Split (%)		76.7%	76.7%		23.3%	23.3%
Maximum Green (s)		65.0	65.0		17.0	17.0
Yellow Time (s)		3.0	3.0		3.0	3.0
All-Red Time (s)		1.0	1.0		1.0	1.0
Lost Time Adjust (s)		0.0	0.0		0.0	0.0
Total Lost Time (s)		4.0	4.0		4.0	4.0
Lead/Lag						
Lead-Lag Optimize?						
Vehicle Extension (s)		3.0	3.0		3.0	3.0
Recall Mode		None	None		None	None
Walk Time (s)			7.0			
Flash Don't Walk (s)			27.0			
Pedestrian Calls (#/hr)			0			
Act Effct Green (s)		19.8	19.8		9.1	9.1
Actuated g/C Ratio		0.53	0.53		0.24	0.24
v/c Ratio		0.26	0.66		0.38	0.30
Control Delay (s/veh)		5.5	10.1		16.7	5.5
Queue Delay		0.0	0.0		0.0	0.0
Total Delay (s/veh)		5.5	10.1		16.7	5.5
LOS		A	B		B	A
Approach Delay (s/veh)		5.5	10.1		11.3	
Approach LOS		A	B		B	

Intersection Summary

Area Type:	Other
Cycle Length:	90
Actuated Cycle Length:	37.4
Natural Cycle:	50
Control Type:	Actuated-Uncoordinated
Maximum v/c Ratio:	0.66
Intersection Signal Delay (s/veh):	9.4
Intersection LOS:	A
Intersection Capacity Utilization:	60.1%
ICU Level of Service:	B
Analysis Period (min):	15

Splits and Phases: 4: Shiloh Road & US 101 SB Off-Ramp

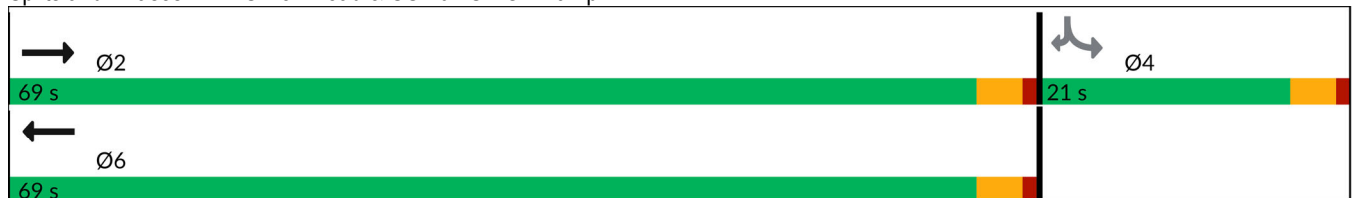



















Lanes, Volumes, Timings  
5: Caletti Ave & Shiloh Road

Existing Project Alter. B Conditions  
Timing Plan: A.M. PEAK

	→	↘	↙	←	↖	↗
Lane Group	EBT	EBR	WBL	WBT	NBL	NBR
Lane Configurations	↑↑		↘	↑	↘	↗
Traffic Volume (vph)	532	22	177	557	7	121
Future Volume (vph)	532	22	177	557	7	121
Ideal Flow (vphpl)	1900	1900	1900	1900	1900	1900
Storage Length (ft)		0	68		0	0
Storage Lanes		0	1		1	1
Taper Length (ft)			50		25	
Lane Util. Factor	0.95	0.95	1.00	1.00	1.00	1.00
Frt	0.994					0.850
Flt Protected			0.950		0.950	
Satd. Flow (prot)	3518	0	1770	1863	1770	1583
Flt Permitted			0.950		0.950	
Satd. Flow (perm)	3518	0	1770	1863	1770	1583
Link Speed (mph)	40			40	30	
Link Distance (ft)	1081			184	459	
Travel Time (s)	18.4			3.1	10.4	
Peak Hour Factor	0.96	0.96	0.87	0.87	0.84	0.84
Adj. Flow (vph)	554	23	203	640	8	144
Shared Lane Traffic (%)						
Lane Group Flow (vph)	577	0	203	640	8	144
Enter Blocked Intersection	No	No	No	No	No	No
Lane Alignment	Left	Right	Left	Left	Left	Right
Median Width(ft)	12			12	12	
Link Offset(ft)	0			0	0	
Crosswalk Width(ft)	16			16	16	
Two way Left Turn Lane						
Headway Factor	1.00	1.00	1.00	1.00	1.00	1.00
Turning Speed (mph)		9	15		15	9
Sign Control	Free			Free	Stop	
<b>Intersection Summary</b>						
Area Type:	Other					
Control Type:	Unsignalized					
Intersection Capacity Utilization	39.3%			ICU Level of Service A		
Analysis Period (min)	15					

Lanes, Volumes, Timings  
6: Conde Lane & Shiloh Road

Existing Project Alter. B Conditions  
Timing Plan: A.M. PEAK

												
Lane Group	EBL	EBT	EBR	WBL	WBT	WBR	NBL	NBT	NBR	SBL	SBT	SBR
Lane Configurations												
Traffic Volume (vph)	25	337	5	9	361	204	4	0	12	205	1	35
Future Volume (vph)	25	337	5	9	361	204	4	0	12	205	1	35
Ideal Flow (vphpl)	1900	1900	1900	1900	1900	1900	1900	1900	1900	1900	1900	1900
Storage Length (ft)	90		0	127		0	0		0	0		40
Storage Lanes	1		0	1		0	0		0	0		1
Taper Length (ft)	70			40			25			25		
Lane Util. Factor	1.00	0.95	0.95	1.00	0.95	0.95	1.00	1.00	1.00	1.00	1.00	1.00
Frt		0.998			0.946			0.899				0.850
Flt Protected	0.950			0.950				0.988			0.953	
Satd. Flow (prot)	1770	3532	0	1770	3348	0	0	1655	0	0	1775	1583
Flt Permitted	0.950			0.950				0.988			0.953	
Satd. Flow (perm)	1770	3532	0	1770	3348	0	0	1655	0	0	1775	1583
Right Turn on Red			Yes			Yes			Yes			No
Satd. Flow (RTOR)		1			114			89				
Link Speed (mph)		40			40			30				35
Link Distance (ft)		815			1081			418				522
Travel Time (s)		13.9			18.4			9.5				10.2
Peak Hour Factor	0.95	0.95	0.95	0.85	0.85	0.85	0.57	0.57	0.57	0.86	0.86	0.86
Adj. Flow (vph)	26	355	5	11	425	240	7	0	21	238	1	41
Shared Lane Traffic (%)												
Lane Group Flow (vph)	26	360	0	11	665	0	0	28	0	0	239	41
Enter Blocked Intersection	No	No	No	No	No	No	No	No	No	No	No	No
Lane Alignment	Left	Left	Right	Left	Left	Right	Left	Left	Right	Left	Left	Right
Median Width(ft)		12			12			0				0
Link Offset(ft)		0			0			0				0
Crosswalk Width(ft)		16			16			16				16
Two way Left Turn Lane												
Headway Factor	1.00	1.00	1.00	1.00	1.00	1.00	1.00	1.00	1.00	1.00	1.00	1.00
Turning Speed (mph)	15		9	15		9	15		9	15		9
Number of Detectors	1	2		1	2		1	2		1	1	1
Detector Template	Left	Thru		Left	Thru		Left	Thru		Left	Thru	Right
Leading Detector (ft)	20	100		20	100		20	100		20	30	20
Trailing Detector (ft)	0	0		0	0		0	0		0	0	0
Detector 1 Position(ft)	0	0		0	0		0	0		0	0	0
Detector 1 Size(ft)	20	6		20	6		20	6		20	30	20
Detector 1 Type	Cl+Ex	Cl+Ex		Cl+Ex	Cl+Ex		Cl+Ex	Cl+Ex		Cl+Ex	Cl+Ex	Cl+Ex
Detector 1 Channel												
Detector 1 Extend (s)	0.0	0.0		0.0	0.0		0.0	0.0		0.0	0.0	0.0
Detector 1 Queue (s)	0.0	0.0		0.0	0.0		0.0	0.0		0.0	0.0	0.0
Detector 1 Delay (s)	0.0	0.0		0.0	0.0		0.0	0.0		0.0	0.0	0.0
Detector 2 Position(ft)		94			94			94				
Detector 2 Size(ft)		6			6			6				
Detector 2 Type		Cl+Ex			Cl+Ex			Cl+Ex				
Detector 2 Channel												
Detector 2 Extend (s)		0.0			0.0			0.0				
Turn Type	Prot	NA		Prot	NA		Split	NA		Split	NA	custom
Protected Phases	5	2		1	6		7	7		4	4	
Permitted Phases												6

Lanes, Volumes, Timings  
6: Conde Lane & Shiloh Road

Existing Project Alter. B Conditions  
Timing Plan: A.M. PEAK

Lane Group	EBL	EBT	EBR	WBL	WBT	WBR	NBL	NBT	NBR	SBL	SBT	SBR
Detector Phase	5	2		1	6		7	7		4	4	6
Switch Phase												
Minimum Initial (s)	8.0	8.0		8.0	8.0		10.0	10.0		11.0	11.0	8.0
Minimum Split (s)	12.0	46.0		12.0	12.0		37.0	37.0		15.0	15.0	12.0
Total Split (s)	13.0	46.0		12.0	45.0		37.0	37.0		15.0	15.0	45.0
Total Split (%)	11.8%	41.8%		10.9%	40.9%		33.6%	33.6%		13.6%	13.6%	40.9%
Maximum Green (s)	9.0	42.0		8.0	41.0		33.0	33.0		11.0	11.0	41.0
Yellow Time (s)	3.0	3.0		3.0	3.0		3.0	3.0		3.0	3.0	3.0
All-Red Time (s)	1.0	1.0		1.0	1.0		1.0	1.0		1.0	1.0	1.0
Lost Time Adjust (s)	0.0	0.0		0.0	0.0		0.0	0.0		0.0	0.0	0.0
Total Lost Time (s)	4.0	4.0		4.0	4.0		4.0	4.0		4.0	4.0	4.0
Lead/Lag	Lead	Lag		Lead	Lag							Lag
Lead-Lag Optimize?	Yes	Yes		Yes	Yes							Yes
Vehicle Extension (s)	3.0	3.0		3.0	3.0		3.0	3.0		3.0	3.0	3.0
Recall Mode	None	None		None	None		None	None		None	None	None
Walk Time (s)		7.0					7.0	7.0				
Flash Don't Walk (s)		35.0					26.0	26.0				
Pedestrian Calls (#/hr)		0					0	0				
Act Effct Green (s)	9.3	16.6		9.3	14.9			11.7			12.9	14.9
Actuated g/C Ratio	0.21	0.38		0.21	0.34			0.27			0.29	0.34
v/c Ratio	0.07	0.27		0.03	0.55			0.06			0.46	0.08
Control Delay (s/veh)	23.8	11.2		23.9	13.3			0.2			25.0	14.1
Queue Delay	0.0	0.0		0.0	0.0			0.0			0.0	0.0
Total Delay (s/veh)	23.8	11.2		23.9	13.3			0.2			25.0	14.1
LOS	C	B		C	B			A			C	B
Approach Delay (s/veh)		12.1			13.5			0.2			23.4	
Approach LOS		B			B			A			C	

Intersection Summary





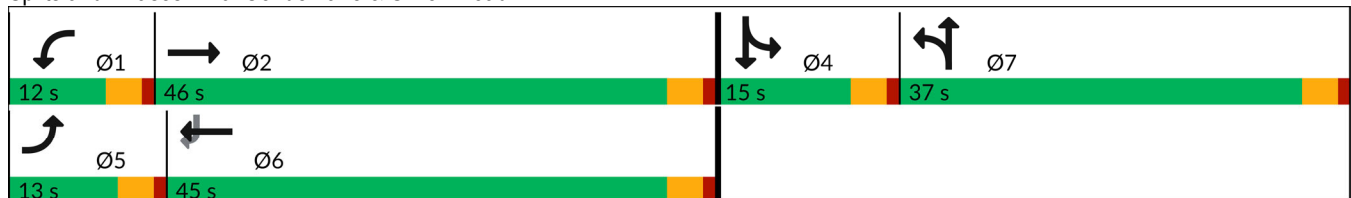













Area Type:	Other
Cycle Length:	110
Actuated Cycle Length:	44.1
Natural Cycle:	110
Control Type:	Actuated-Uncoordinated
Maximum v/c Ratio:	0.55
Intersection Signal Delay (s/veh):	14.8
Intersection LOS:	B
Intersection Capacity Utilization:	45.5%
ICU Level of Service:	A
Analysis Period (min):	15

Splits and Phases: 6: Conde Lane & Shiloh Road



Lanes, Volumes, Timings  
7: Driveway 1/Gridley Drive & Shiloh Road





















Existing Project Alter. B Conditions  
Timing Plan: A.M. PEAK

												
Lane Group	EBL	EBT	EBR	WBL	WBT	WBR	NBL	NBT	NBR	SBL	SBT	SBR
Lane Configurations												
Traffic Volume (vph)	8	286	47	0	159	0	33	0	0	1	0	16
Future Volume (vph)	8	286	47	0	159	0	33	0	0	1	0	16
Ideal Flow (vphp)	1900	1900	1900	1900	1900	1900	1900	1900	1900	1900	1900	1900
Storage Length (ft)	0		150	0		0	0		0	0		0
Storage Lanes	0		1	0		0	1		0	0		0
Taper Length (ft)	25			25			25			25		
Lane Util. Factor	1.00	1.00	1.00	1.00	1.00	1.00	1.00	1.00	1.00	1.00	1.00	1.00
Ped Bike Factor												
Frt			0.850									0.871
Flt Protected		0.999					0.950					0.998
Satd. Flow (prot)	0	1861	1583	0	1863	0	1770	1863	0	0	1619	0
Flt Permitted		0.999					0.950					0.998
Satd. Flow (perm)	0	1861	1583	0	1863	0	1770	1863	0	0	1619	0
Link Speed (mph)		40			40			30			30	
Link Distance (ft)		608			2146			248			715	
Travel Time (s)		10.4			36.6			5.6			16.3	
Confl. Bikes (#/hr)			1									
Peak Hour Factor	0.91	0.91	0.91	0.85	0.85	0.85	1.00	1.00	1.00	0.71	0.71	0.71
Adj. Flow (vph)	9	314	52	0	187	0	33	0	0	1	0	23
Shared Lane Traffic (%)												
Lane Group Flow (vph)	0	323	52	0	187	0	33	0	0	0	24	0
Enter Blocked Intersection	No	No	No	No	No	No	No	No	No	No	No	No
Lane Alignment	Left	Left	Right	Left	Left	Right	Left	Left	Right	Left	Left	Right
Median Width(ft)		0			0			12			12	
Link Offset(ft)		0			0			0			0	
Crosswalk Width(ft)		16			16			16			16	
Two way Left Turn Lane												
Headway Factor	1.00	1.00	1.00	1.00	1.00	1.00	1.00	1.00	1.00	1.00	1.00	1.00
Turning Speed (mph)	15		9	15		9	15		9	15		9
Sign Control		Free			Free			Stop			Stop	
<b>Intersection Summary</b>												
Area Type:	Other											
Control Type:	Unsignalized											
Intersection Capacity Utilization	36.7%						ICU Level of Service A					
Analysis Period (min)	15											

Lanes, Volumes, Timings  
8: Old Redwood Hwy & Driveway 2

Existing Project Alter. B Conditions

Timing Plan: A.M. PEAK

												
Lane Group	EBL	EBT	EBR	WBL	WBT	WBR	NBL	NBT	NBR	SBL	SBT	SBR
Lane Configurations												
Traffic Volume (vph)	1	0	0	19	0	31	0	217	28	45	316	0
Future Volume (vph)	1	0	0	19	0	31	0	217	28	45	316	0
Ideal Flow (vphp)	1900	1900	1900	1900	1900	1900	1900	1900	1900	1900	1900	1900
Storage Length (ft)	0		0	0		0	0		100	50		0
Storage Lanes	0		0	1		0	0		1	1		0
Taper Length (ft)	25			25			25			25		
Lane Util. Factor	1.00	1.00	1.00	1.00	1.00	1.00	1.00	1.00	1.00	1.00	1.00	1.00
Ped Bike Factor												
Frt					0.850				0.850			
Flt Protected		0.950		0.950						0.950		
Satd. Flow (prot)	0	1770	0	1770	1583	0	0	1863	1583	1770	1863	0
Flt Permitted		0.950		0.950						0.950		
Satd. Flow (perm)	0	1770	0	1770	1583	0	0	1863	1583	1770	1863	0
Link Speed (mph)		30			30			45			45	
Link Distance (ft)		98			385			520			748	
Travel Time (s)		2.2			8.8			7.9			11.3	
Confl. Peds. (#/hr)									1	1		
Confl. Bikes (#/hr)									1			2
Peak Hour Factor	0.25	0.25	0.25	1.00	1.00	1.00	0.99	0.99	0.99	0.90	0.90	0.90
Adj. Flow (vph)	4	0	0	19	0	31	0	219	28	50	351	0
Shared Lane Traffic (%)												
Lane Group Flow (vph)	0	4	0	19	31	0	0	219	28	50	351	0
Enter Blocked Intersection	No	No	No	No	No	No	No	No	No	No	No	No
Lane Alignment	Left	Left	Right	Left	Left	Right	Left	Left	Right	Left	Left	Right
Median Width(ft)		12			12			12			12	
Link Offset(ft)		0			0			0			0	
Crosswalk Width(ft)		16			16			16			16	
Two way Left Turn Lane												
Headway Factor	1.00	1.00	1.00	1.00	1.00	1.00	1.00	1.00	1.00	1.00	1.00	1.00
Turning Speed (mph)	15		9	15		9	15		9	15		9
Sign Control		Stop			Stop			Free			Free	
<b>Intersection Summary</b>												
Area Type:	Other											
Control Type:	Unsignalized											
Intersection Capacity Utilization	41.4%						ICU Level of Service A					
Analysis Period (min)	15											



Lanes, Volumes, Timings  
9: Driveway 3 & Shiloh Road

Existing Project Alter. B Conditions

Timing Plan: A.M. PEAK

	→	↘	↙	←	↖	↗
Lane Group	EBT	EBR	WBL	WBT	NBL	NBR
Lane Configurations	↑	↗		↖	↘	↗
Traffic Volume (vph)	140	145	14	52	101	10
Future Volume (vph)	140	145	14	52	101	10
Ideal Flow (vphpl)	1900	1900	1900	1900	1900	1900
Storage Length (ft)		200	0		0	0
Storage Lanes		1	0		1	1
Taper Length (ft)			25		25	
Lane Util. Factor	1.00	1.00	1.00	1.00	1.00	1.00
Frt		0.850				0.850
Flt Protected				0.990	0.950	
Satd. Flow (prot)	1863	1583	0	1844	1770	1583
Flt Permitted				0.990	0.950	
Satd. Flow (perm)	1863	1583	0	1844	1770	1583
Link Speed (mph)	40			40	30	
Link Distance (ft)	2146			134	402	
Travel Time (s)	36.6			2.3	9.1	
Peak Hour Factor	0.85	0.85	0.81	0.81	1.00	1.00
Adj. Flow (vph)	165	171	17	64	101	10
Shared Lane Traffic (%)						
Lane Group Flow (vph)	165	171	0	81	101	10
Enter Blocked Intersection	No	No	No	No	No	No
Lane Alignment	Left	Right	Left	Left	Left	Right
Median Width(ft)	0			0	12	
Link Offset(ft)	0			0	0	
Crosswalk Width(ft)	16			16	16	
Two way Left Turn Lane						
Headway Factor	1.00	1.00	1.00	1.00	1.00	1.00
Turning Speed (mph)		9	15		15	9
Sign Control	Free			Free	Stop	

Intersection Summary

Area Type:	Other
Control Type:	Unsignalized
Intersection Capacity Utilization	26.5%
ICU Level of Service	A
Analysis Period (min)	15

Lanes, Volumes, Timings

Existing Project Alter. B Conditions

10: US 101 NB Off Ramp/Lakewood Drive & Old Redwood Highway

Timing Plan: A.M. PEAK



Lane Group	EBL	EBT	EBR	WBL	WBT	WBR	NBL	NBT	NBR	SBL	SBT	SBR
Lane Configurations												
Traffic Volume (vph)	152	177	0	0	459	149	227	221	79	118	0	534
Future Volume (vph)	152	177	0	0	459	149	227	221	79	118	0	534
Ideal Flow (vphpl)	1900	1900	1900	1900	1900	1900	1900	1900	1900	1900	1900	1900
Storage Length (ft)	155		0	0		0	270		150	120		0
Storage Lanes	1		0	0		0	1		1	1		1
Taper Length (ft)	50			25			165			75		
Lane Util. Factor	0.97	1.00	1.00	1.00	0.95	0.95	0.91	0.91	0.95	0.97	1.00	1.00
Ped Bike Factor	1.00				1.00			1.00		1.00		
Fr <sub>t</sub>					0.963			0.966				0.850
Fl <sub>t</sub> Protected	0.950						0.950	0.993		0.950		
Satd. Flow (prot)	3433	1863	0	0	3397	0	1610	3242	0	3433	0	1583
Fl <sub>t</sub> Permitted	0.950						0.950	0.993		0.950		
Satd. Flow (perm)	3431	1863	0	0	3397	0	1610	3242	0	3427	0	1583
Right Turn on Red			Yes			Yes			Yes			Yes
Satd. Flow (RTOR)					50			41				299
Link Speed (mph)		35			35			30				30
Link Distance (ft)		226			617			716				478
Travel Time (s)		4.4			12.0			16.3				10.9
Confl. Peds. (#/hr)	1		1	1		1			2	2		
Confl. Bikes (#/hr)			1			1						
Peak Hour Factor	0.85	0.85	0.85	0.83	0.83	0.83	0.90	0.90	0.90	0.89	0.89	0.89
Adj. Flow (vph)	179	208	0	0	553	180	252	246	88	133	0	600
Shared Lane Traffic (%)							23%					
Lane Group Flow (vph)	179	208	0	0	733	0	194	392	0	133	0	600
Enter Blocked Intersection	No	No	No	No	No	No	No	No	No	No	No	No
Lane Alignment	Left	Left	Right	Left	Left	Right	Left	Left	Right	Left	Left	Right
Median Width(ft)		24			24			24				24
Link Offset(ft)		0			0			0				0
Crosswalk Width(ft)		16			16			16				16
Two way Left Turn Lane												
Headway Factor	1.00	1.00	1.00	1.00	1.00	1.00	1.00	1.00	1.00	1.00	1.00	1.00
Turning Speed (mph)	15		9	15		9	15		9	15		9
Number of Detectors	1	2			2		1	2		1		1
Detector Template	Left	Thru			Thru		Left	Thru		Left		Right
Leading Detector (ft)	20	100			100		20	100		20		20
Trailing Detector (ft)	0	0			0		0	0		0		0
Detector 1 Position(ft)	0	0			0		0	0		0		0
Detector 1 Size(ft)	20	6			6		20	6		20		20
Detector 1 Type	Cl+Ex	Cl+Ex			Cl+Ex		Cl+Ex	Cl+Ex		Cl+Ex		Cl+Ex
Detector 1 Channel												
Detector 1 Extend (s)	0.0	0.0			0.0		0.0	0.0		0.0		0.0
Detector 1 Queue (s)	0.0	0.0			0.0		0.0	0.0		0.0		0.0
Detector 1 Delay (s)	0.0	0.0			0.0		0.0	0.0		0.0		0.0
Detector 2 Position(ft)		94			94			94				
Detector 2 Size(ft)		6			6			6				
Detector 2 Type		Cl+Ex			Cl+Ex			Cl+Ex				
Detector 2 Channel												
Detector 2 Extend (s)		0.0			0.0			0.0				

Lanes, Volumes, Timings

Existing Project Alter. B Conditions

10: US 101 NB Off Ramp/Lakewood Drive & Old Redwood Highway

Timing Plan: A.M. PEAK



Lane Group	EBL	EBT	EBR	WBL	WBT	WBR	NBL	NBT	NBR	SBL	SBT	SBR
Turn Type	Prot	NA			NA		Split	NA		Prot		pm+ov
Protected Phases	5	2			6		8	8		7		5
Permitted Phases												5 8
Detector Phase	5	2			6		8	8		7		5
Switch Phase												
Minimum Initial (s)	7.0	10.0			10.0		10.0	10.0		7.0		7.0
Minimum Split (s)	11.0	32.1			32.1		33.7	33.7		11.0		11.0
Total Split (s)	13.0	45.3			32.3		33.7	33.7		11.0		13.0
Total Split (%)	14.4%	50.3%			35.9%		37.4%	37.4%		12.2%		14.4%
Maximum Green (s)	9.0	40.2			27.2		29.0	29.0		7.0		9.0
Yellow Time (s)	3.0	4.1			4.1		3.7	3.7		3.0		3.0
All-Red Time (s)	1.0	1.0			1.0		1.0	1.0		1.0		1.0
Lost Time Adjust (s)	0.0	0.0			0.0		0.0	0.0		0.0		0.0
Total Lost Time (s)	4.0	5.1			5.1		4.7	4.7		4.0		4.0
Lead/Lag	Lead				Lag		Lag	Lag		Lead		Lead
Lead-Lag Optimize?	Yes				Yes		Yes	Yes		Yes		Yes
Vehicle Extension (s)	3.0	3.0			3.0		3.0	3.0		3.0		3.0
Recall Mode	None	Max			Max		None	None		None		None
Walk Time (s)		7.0			7.0		7.0	7.0				
Flash Don't Walk (s)		20.0			17.0		22.0	22.0				
Pedestrian Calls (#/hr)		0			0		0	0				
Act Effct Green (s)	8.4	40.3			27.9		15.8	15.8		7.0		28.9
Actuated g/C Ratio	0.11	0.52			0.36		0.21	0.21		0.09		0.38
v/c Ratio	0.48	0.21			0.58		0.59	0.56		0.42		0.77
Control Delay (s/veh)	37.6	11.6			21.6		35.0	27.4		38.9		17.2
Queue Delay	0.0	0.0			0.0		0.0	0.0		0.0		0.0
Total Delay (s/veh)	37.6	11.6			21.6		35.0	27.4		38.9		17.2
LOS	D	B			C		D	C		D		B
Approach Delay (s/veh)		23.6			21.6			29.9				21.2
Approach LOS		C			C			C				C

Intersection Summary

Area Type: Other  
 Cycle Length: 90  
 Actuated Cycle Length: 77  
 Natural Cycle: 90  
 Control Type: Actuated-Uncoordinated  
 Maximum v/c Ratio: 0.77  
 Intersection Signal Delay (s/veh): 23.8  
 Intersection LOS: C  
 Intersection Capacity Utilization 75.7%  
 ICU Level of Service D  
 Analysis Period (min) 15

Splits and Phases: 10: US 101 NB Off Ramp/Lakewood Drive & Old Redwood Highway

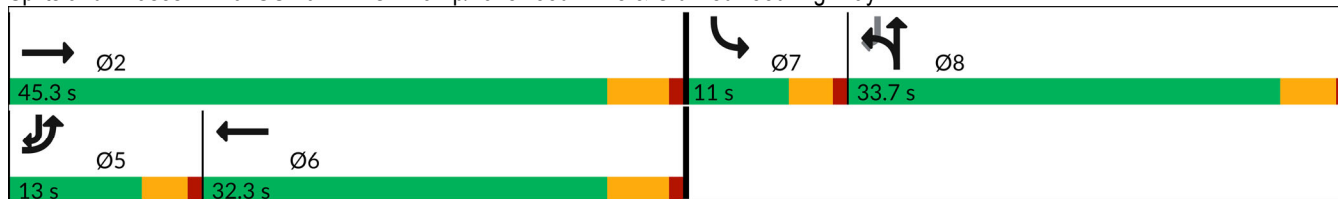

Lanes, Volumes, Timings  
 11: Old Redwood Highway & US 101 NB On Ramp

Existing Project Alter. B Conditions

Timing Plan: A.M. PEAK

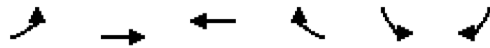

Lane Group	EBL	EBT	WBT	WBR	SBL	SBR
Lane Configurations	↶	↷	↶	↷		
Traffic Volume (vph)	86	327	1012	190	0	0
Future Volume (vph)	86	327	1012	190	0	0
Ideal Flow (vphp)	1900	1900	1900	1900	1900	1900
Storage Length (ft)	245			0	0	0
Storage Lanes	1			0	0	0
Taper Length (ft)	50				25	
Lane Util. Factor	1.00	0.95	0.95	0.95	1.00	1.00
Ped Bike Factor						
Frt			0.976			
Flt Protected	0.950					
Satd. Flow (prot)	1770	3539	3454	0	0	0
Flt Permitted	0.950					
Satd. Flow (perm)	1770	3539	3454	0	0	0
Link Speed (mph)		35	35		30	
Link Distance (ft)		531	226		299	
Travel Time (s)		10.3	4.4		6.8	
Confl. Peds. (#/hr)	9					
Confl. Bikes (#/hr)				1		
Peak Hour Factor	0.81	0.81	0.89	0.89	0.25	0.25
Adj. Flow (vph)	106	404	1137	213	0	0
Shared Lane Traffic (%)						
Lane Group Flow (vph)	106	404	1350	0	0	0
Enter Blocked Intersection	No	No	No	No	No	No
Lane Alignment	Left	Left	Left	Right	Left	Right
Median Width(ft)		12	12		0	
Link Offset(ft)		0	0		0	
Crosswalk Width(ft)		16	16		16	
Two way Left Turn Lane						
Headway Factor	1.00	1.00	1.00	1.00	1.00	1.00
Turning Speed (mph)	15			9	15	9
Sign Control		Free	Free		Free	

Intersection Summary

Area Type:	Other
Control Type:	Unsignalized
Intersection Capacity Utilization	70.8%
Analysis Period (min)	15
	ICU Level of Service C

Lanes, Volumes, Timings

Existing Project Alter. B Conditions

12: US 101 SB On Ramp/US 101 SB Off Ramp & Old Redwood Highway

Timing Plan: A.M. PEAK



Lane Group	EBL	EBT	EBR	WBL	WBT	WBR	NBL	NBT	NBR	SBL	SBT	SBR
Lane Configurations		↑↑	↗	↘	↑↑					↘	↕	
Traffic Volume (vph)	0	298	296	513	504	0	0	0	0	120	1	65
Future Volume (vph)	0	298	296	513	504	0	0	0	0	120	1	65
Ideal Flow (vphpl)	1900	1900	1900	1900	1900	1900	1900	1900	1900	1900	1900	1900
Storage Length (ft)	0		0	250		0	0		0	420		0
Storage Lanes	0		1	0		0	0		0	1		0
Taper Length (ft)	25			165			25			75		
Lane Util. Factor	1.00	0.95	1.00	1.00	0.95	1.00	1.00	1.00	1.00	0.95	0.95	1.00
Ped Bike Factor			0.98	1.00								
Frt			0.850								0.890	
Flt Protected				0.950						0.950	0.987	
Satd. Flow (prot)	0	3539	1583	1770	3539	0	0	0	0	1681	1554	0
Flt Permitted				0.950						0.950	0.987	
Satd. Flow (perm)	0	3539	1558	1767	3539	0	0	0	0	1681	1554	0
Right Turn on Red			Yes			Yes			Yes			Yes
Satd. Flow (RTOR)			322								80	
Link Speed (mph)		35			35			30			30	
Link Distance (ft)		423			531			621			831	
Travel Time (s)		8.2			10.3			14.1			18.9	
Confl. Peds. (#/hr)	10		3	3		10						
Confl. Bikes (#/hr)			2									
Peak Hour Factor	0.92	0.92	0.92	0.89	0.89	0.89	0.25	0.25	0.25	0.81	0.81	0.81
Adj. Flow (vph)	0	324	322	576	566	0	0	0	0	148	1	80
Shared Lane Traffic (%)										19%		
Lane Group Flow (vph)	0	324	322	576	566	0	0	0	0	120	109	0
Enter Blocked Intersection	No	No	No	No	No	No	No	No	No	No	No	No
Lane Alignment	Left	Left	Right	Left	Left	Right	Left	Left	Right	Left	Left	Right
Median Width(ft)		24			24			12			12	
Link Offset(ft)		0			0			0			0	
Crosswalk Width(ft)		16			16			16			16	
Two way Left Turn Lane												
Headway Factor	1.00	1.00	1.00	1.00	1.00	1.00	1.00	1.00	1.00	1.00	1.00	1.00
Turning Speed (mph)	15		9	15		9	15		9	15		9
Number of Detectors		2	1	1	2					1	2	
Detector Template		Thru	Right	Left	Thru					Left	Thru	
Leading Detector (ft)		100	20	20	100					20	100	
Trailing Detector (ft)		0	0	0	0					0	0	
Detector 1 Position(ft)		0	0	0	0					0	0	
Detector 1 Size(ft)		6	20	20	6					20	6	
Detector 1 Type		Cl+Ex	Cl+Ex	Cl+Ex	Cl+Ex					Cl+Ex	Cl+Ex	
Detector 1 Channel												
Detector 1 Extend (s)		0.0	0.0	0.0	0.0					0.0	0.0	
Detector 1 Queue (s)		0.0	0.0	0.0	0.0					0.0	0.0	
Detector 1 Delay (s)		0.0	0.0	0.0	0.0					0.0	0.0	
Detector 2 Position(ft)		94			94							94
Detector 2 Size(ft)		6			6							6
Detector 2 Type		Cl+Ex			Cl+Ex							Cl+Ex
Detector 2 Channel												
Detector 2 Extend (s)		0.0			0.0							0.0

Lanes, Volumes, Timings

Existing Project Alter. B Conditions

12: US 101 SB On Ramp/US 101 SB Off Ramp & Old Redwood Highway

Timing Plan: A.M. PEAK



Lane Group	EBL	EBT	EBR	WBL	WBT	WBR	NBL	NBT	NBR	SBL	SBT	SBR
Turn Type		NA	Perm	Prot	NA					Perm	NA	
Protected Phases		6		5	2						8	
Permitted Phases			6							8		
Detector Phase		6	6	5	2					8	8	
Switch Phase												
Minimum Initial (s)		10.0	10.0	7.0	10.0					10.0	10.0	
Minimum Split (s)		32.1	32.1	11.0	38.1					14.7	14.7	
Total Split (s)		32.3	32.3	33.0	65.3					14.7	14.7	
Total Split (%)		40.4%	40.4%	41.3%	81.6%					18.4%	18.4%	
Maximum Green (s)		27.2	27.2	29.0	60.2					10.0	10.0	
Yellow Time (s)		4.1	4.1	3.0	4.1					3.7	3.7	
All-Red Time (s)		1.0	1.0	1.0	1.0					1.0	1.0	
Lost Time Adjust (s)		0.0	0.0	0.0	0.0					0.0	0.0	
Total Lost Time (s)		5.1	5.1	4.0	5.1					4.7	4.7	
Lead/Lag		Lag	Lag	Lead								
Lead-Lag Optimize?		Yes	Yes	Yes								
Vehicle Extension (s)		3.0	3.0	3.0	3.0					3.0	3.0	
Recall Mode		Max	Max	None	Max					None	None	
Walk Time (s)		7.0	7.0		7.0							
Flash Don't Walk (s)		20.0	20.0		25.0							
Pedestrian Calls (#/hr)		0	0		0							
Act Effct Green (s)		28.1	28.1	28.1	60.2					10.0	10.0	
Actuated g/C Ratio		0.35	0.35	0.35	0.75					0.13	0.13	
v/c Ratio		0.26	0.43	0.93	0.21					0.57	0.41	
Control Delay (s/veh)		19.6	4.4	48.8	3.1					44.7	17.5	
Queue Delay		0.0	0.0	0.0	0.0					0.0	0.0	
Total Delay (s/veh)		19.6	4.4	48.8	3.1					44.7	17.5	
LOS		B	A	D	A					D	B	
Approach Delay (s/veh)		12.0			26.2						31.8	
Approach LOS		B			C						C	

Intersection Summary

Area Type: Other  
 Cycle Length: 80  
 Actuated Cycle Length: 80  
 Natural Cycle: 80  
 Control Type: Actuated-Uncoordinated  
 Maximum v/c Ratio: 0.93  
 Intersection Signal Delay (s/veh): 22.3  
 Intersection LOS: C  
 Intersection Capacity Utilization 70.8%  
 ICU Level of Service C  
 Analysis Period (min) 15



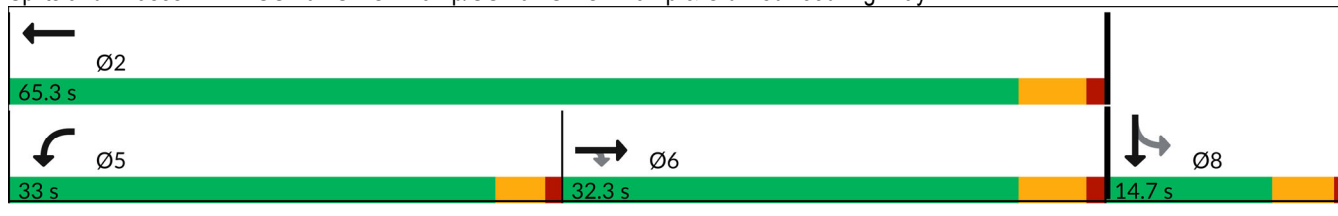



















Splits and Phases: 12: US 101 SB On Ramp/US 101 SB Off Ramp & Old Redwood Highway



Lanes, Volumes, Timings  
1: Old Redwood Hwy & Shiloh Road

Existing Project Alter. B Conditions

Timing Plan: P.M. Peak

												
Lane Group	EBL	EBT	EBR	WBL	WBT	WBR	NBL	NBT	NBR	SBL	SBT	SBR
Lane Configurations												
Traffic Volume (vph)	241	356	223	37	332	49	198	345	21	59	242	146
Future Volume (vph)	241	356	223	37	332	49	198	345	21	59	242	146
Ideal Flow (vphpl)	1900	1900	1900	1900	1900	1900	1900	1900	1900	1900	1900	1900
Storage Length (ft)	375		140	0		50	200		98	130		93
Storage Lanes	1		1	0		1	1		1	1		1
Taper Length (ft)	50			25			60			93		
Lane Util. Factor	1.00	1.00	1.00	1.00	1.00	1.00	1.00	1.00	1.00	1.00	1.00	1.00
Ped Bike Factor	1.00					0.98	1.00		0.98			0.97
Frt			0.850			0.850			0.850			0.850
Flt Protected	0.950				0.995		0.950			0.950		
Satd. Flow (prot)	1770	1863	1583	0	1853	1583	1770	1863	1583	1770	1863	1583
Flt Permitted	0.950				0.995		0.950			0.950		
Satd. Flow (perm)	1768	1863	1583	0	1853	1549	1767	1863	1546	1770	1863	1542
Right Turn on Red			Yes			Yes			Yes			Yes
Satd. Flow (RTOR)			142			105			77			105
Link Speed (mph)		40			40			45			40	
Link Distance (ft)		1789			608			748			775	
Travel Time (s)		30.5			10.4			11.3			13.2	
Confl. Peds. (#/hr)	1						1	1				1
Confl. Bikes (#/hr)									3			3
Peak Hour Factor	0.97	0.97	0.97	0.91	0.91	0.91	0.93	0.93	0.93	0.93	0.93	0.93
Adj. Flow (vph)	248	367	230	41	365	54	213	371	23	63	260	157
Shared Lane Traffic (%)												
Lane Group Flow (vph)	248	367	230	0	406	54	213	371	23	63	260	157
Enter Blocked Intersection	No	No	No	No	No	No	No	No	No	No	No	No
Lane Alignment	Left	Left	Right	Left	Left	Right	Left	Left	Right	Left	Left	Right
Median Width(ft)		12			12			12			12	
Link Offset(ft)		0			0			0			0	
Crosswalk Width(ft)		16			16			16			16	
Two way Left Turn Lane												
Headway Factor	1.00	1.00	1.00	1.00	1.00	1.00	1.00	1.00	1.00	1.00	1.00	1.00
Turning Speed (mph)	15		9	15		9	15		9	15		9
Number of Detectors	1	2	1	1	2	1	1	2	1	1	2	1
Detector Template	Left	Thru	Right	Left	Thru	Right	Left	Thru	Right	Left	Thru	Right
Leading Detector (ft)	20	100	20	20	100	20	20	100	20	20	100	20
Trailing Detector (ft)	0	0	0	0	0	0	0	0	0	0	0	0
Detector 1 Position(ft)	0	0	0	0	0	0	0	0	0	0	0	0
Detector 1 Size(ft)	20	6	20	20	6	20	20	6	20	20	6	20
Detector 1 Type	Cl+Ex	Cl+Ex	Cl+Ex	Cl+Ex	Cl+Ex	Cl+Ex	Cl+Ex	Cl+Ex	Cl+Ex	Cl+Ex	Cl+Ex	Cl+Ex
Detector 1 Channel												
Detector 1 Extend (s)	0.0	0.0	0.0	0.0	0.0	0.0	0.0	0.0	0.0	0.0	0.0	0.0
Detector 1 Queue (s)	0.0	0.0	0.0	0.0	0.0	0.0	0.0	0.0	0.0	0.0	0.0	0.0
Detector 1 Delay (s)	0.0	0.0	0.0	0.0	0.0	0.0	0.0	0.0	0.0	0.0	0.0	0.0
Detector 2 Position(ft)		94			94			94			94	
Detector 2 Size(ft)		6			6			6			6	
Detector 2 Type		Cl+Ex			Cl+Ex			Cl+Ex			Cl+Ex	
Detector 2 Channel												
Detector 2 Extend (s)		0.0			0.0			0.0			0.0	

Lanes, Volumes, Timings  
1: Old Redwood Hwy & Shiloh Road

Existing Project Alter. B Conditions  
Timing Plan: P.M. Peak

Lane Group	EBL	EBT	EBR	WBL	WBT	WBR	NBL	NBT	NBR	SBL	SBT	SBR
Turn Type	Split	NA	Perm	Split	NA	Perm	Prot	NA	Perm	Prot	NA	Perm
Protected Phases	2	2		6	6		3	8		7	4	
Permitted Phases			2			6			8			4
Detector Phase	2	2	2	6	6	6	3	8	8	7	4	4
Switch Phase												
Minimum Initial (s)	5.0	5.0	5.0	5.0	5.0	5.0	5.0	5.0	5.0	5.0	5.0	5.0
Minimum Split (s)	34.5	34.5	34.5	42.5	42.5	42.5	8.5	46.5	46.5	8.5	39.5	39.5
Total Split (s)	35.0	35.0	35.0	42.5	42.5	42.5	18.0	48.0	48.0	9.5	39.5	39.5
Total Split (%)	25.9%	25.9%	25.9%	31.5%	31.5%	31.5%	13.3%	35.6%	35.6%	7.0%	29.3%	29.3%
Maximum Green (s)	30.5	30.5	30.5	38.0	38.0	38.0	14.5	43.5	43.5	6.0	35.0	35.0
Yellow Time (s)	3.5	3.5	3.5	3.5	3.5	3.5	3.0	3.5	3.5	3.0	3.5	3.5
All-Red Time (s)	1.0	1.0	1.0	1.0	1.0	1.0	0.5	1.0	1.0	0.5	1.0	1.0
Lost Time Adjust (s)	0.0	0.0	0.0		0.0	0.0	0.0	0.0	0.0	0.0	0.0	0.0
Total Lost Time (s)	4.5	4.5	4.5		4.5	4.5	3.5	4.5	4.5	3.5	4.5	4.5
Lead/Lag	Lead	Lead	Lead	Lag	Lag	Lag	Lead	Lag	Lag	Lead	Lag	Lag
Lead-Lag Optimize?	Yes	Yes	Yes	Yes	Yes	Yes	Yes	Yes	Yes	Yes	Yes	Yes
Vehicle Extension (s)	3.0	3.0	3.0	3.0	3.0	3.0	3.0	3.0	3.0	3.0	3.0	3.0
Recall Mode	None	None	None	None	None	None	None	None	None	None	None	None
Walk Time (s)	7.0	7.0	7.0	7.0	7.0	7.0		7.0	7.0		7.0	7.0
Flash Don't Walk (s)	23.0	23.0	23.0	31.0	31.0	31.0		35.0	35.0		28.0	28.0
Pedestrian Calls (#/hr)	0	0	0	0	0	0		0	0		0	0
Act Effct Green (s)	26.9	26.9	26.9		29.3	29.3	15.0	30.2	30.2	6.2	21.4	21.4
Actuated g/C Ratio	0.24	0.24	0.24		0.27	0.27	0.14	0.27	0.27	0.06	0.19	0.19
v/c Ratio	0.57	0.81	0.47		0.83	0.11	0.89	0.73	0.05	0.64	0.72	0.41
Control Delay (s/veh)	44.9	55.7	18.9		54.1	0.4	85.7	46.9	0.2	84.4	54.9	18.7
Queue Delay	0.0	0.0	0.0		0.0	0.0	0.0	0.0	0.0	0.0	0.0	0.0
Total Delay (s/veh)	44.9	55.7	18.9		54.1	0.4	85.7	46.9	0.2	84.4	54.9	18.7
LOS	D	E	B		D	A	F	D	A	F	D	B
Approach Delay (s/veh)		42.5			47.8			58.8			47.0	
Approach LOS		D			D			E			D	

Intersection Summary

Area Type: Other  
 Cycle Length: 135  
 Actuated Cycle Length: 110.1  
 Natural Cycle: 135  
 Control Type: Actuated-Uncoordinated  
 Maximum v/c Ratio: 0.89  
 Intersection Signal Delay (s/veh): 48.6  
 Intersection LOS: D  
 Intersection Capacity Utilization 77.5%  
 ICU Level of Service D  
 Analysis Period (min) 15

Splits and Phases: 1: Old Redwood Hwy & Shiloh Road

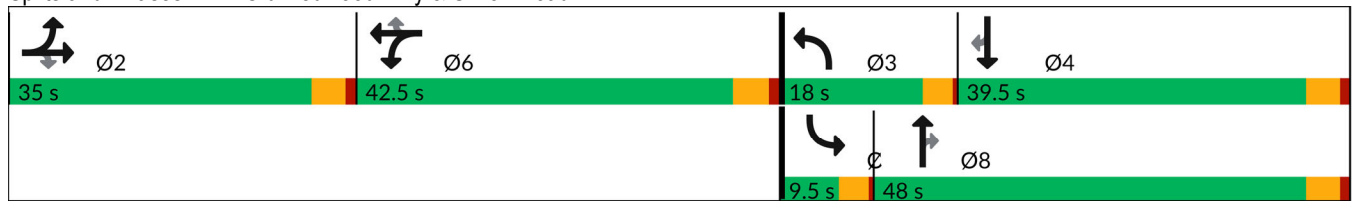



Lanes, Volumes, Timings  
2: Shiloh Road & Hembree Ln

Existing Project Alter. B Conditions

Timing Plan: P.M. Peak

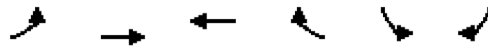

Lane Group	EBL	EBT	WBT	WBR	SBL	SBR
Lane Configurations						
Traffic Volume (vph)	615	669	560	141	170	491
Future Volume (vph)	615	669	560	141	170	491
Ideal Flow (vphp)	1900	1900	1900	1900	1900	1900
Storage Length (ft)	0			130	0	0
Storage Lanes	2			1	1	1
Taper Length (ft)	25				25	
Lane Util. Factor	0.97	1.00	0.95	0.95	1.00	1.00
Ped Bike Factor	1.00		1.00			
Frt			0.970			0.850
Flt Protected	0.950				0.950	
Satd. Flow (prot)	3433	1863	3424	0	1770	1583
Flt Permitted	0.950				0.950	
Satd. Flow (perm)	3430	1863	3424	0	1770	1583
Right Turn on Red				Yes		Yes
Satd. Flow (RTOR)			45			160
Link Speed (mph)		40	40		35	
Link Distance (ft)		302	1789		381	
Travel Time (s)		5.1	30.5		7.4	
Confl. Peds. (#/hr)	2			2		
Peak Hour Factor	0.94	0.94	0.87	0.87	0.95	0.95
Adj. Flow (vph)	654	712	644	162	179	517
Shared Lane Traffic (%)						
Lane Group Flow (vph)	654	712	806	0	179	517
Enter Blocked Intersection	No	No	No	No	No	No
Lane Alignment	Left	Left	Left	Right	Left	Right
Median Width(ft)		24	24		12	
Link Offset(ft)		0	0		0	
Crosswalk Width(ft)		16	16		16	
Two way Left Turn Lane						
Headway Factor	1.00	1.00	1.00	1.00	1.00	1.00
Turning Speed (mph)	15			9	15	9
Number of Detectors	1	2	2		1	1
Detector Template	Left	Thru	Thru		Left	Right
Leading Detector (ft)	20	100	100		20	20
Trailing Detector (ft)	0	0	0		0	0
Detector 1 Position(ft)	0	0	0		0	0
Detector 1 Size(ft)	20	6	6		20	20
Detector 1 Type	Cl+Ex	Cl+Ex	Cl+Ex		Cl+Ex	Cl+Ex
Detector 1 Channel						
Detector 1 Extend (s)	0.0	0.0	0.0		0.0	0.0
Detector 1 Queue (s)	0.0	0.0	0.0		0.0	0.0
Detector 1 Delay (s)	0.0	0.0	0.0		0.0	0.0
Detector 2 Position(ft)		94	94			
Detector 2 Size(ft)		6	6			
Detector 2 Type		Cl+Ex	Cl+Ex			
Detector 2 Channel						
Detector 2 Extend (s)		0.0	0.0			
Turn Type	Prot	NA	NA		Perm	pm+ov

Lanes, Volumes, Timings  
2: Shiloh Road & Hembree Ln

Existing Project Alter. B Conditions  
Timing Plan: P.M. Peak

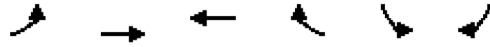

Lane Group	EBL	EBT	WBT	WBR	SBL	SBR
Protected Phases	5	2	6			5
Permitted Phases					4	4 5
Detector Phase	5	2	6		4	5
Switch Phase						
Minimum Initial (s)	3.0	5.0	5.0		5.0	3.0
Minimum Split (s)	7.0	9.0	43.0		9.0	7.0
Total Split (s)	29.0	73.0	44.0		17.0	29.0
Total Split (%)	32.2%	81.1%	48.9%		18.9%	32.2%
Maximum Green (s)	25.0	69.0	40.0		13.0	25.0
Yellow Time (s)	3.0	3.0	3.0		3.0	3.0
All-Red Time (s)	1.0	1.0	1.0		1.0	1.0
Lost Time Adjust (s)	0.0	0.0	0.0		0.0	0.0
Total Lost Time (s)	4.0	4.0	4.0		4.0	4.0
Lead/Lag	Lead		Lag			Lead
Lead-Lag Optimize?	Yes		Yes			Yes
Vehicle Extension (s)	3.0	3.0	3.0		3.0	3.0
Recall Mode	None	None	None		None	None
Walk Time (s)			7.0			
Flash Don't Walk (s)			32.0			
Pedestrian Calls (#/hr)			0			
Act Effct Green (s)	18.9	45.1	22.0		11.4	34.5
Actuated g/C Ratio	0.29	0.70	0.34		0.18	0.53
v/c Ratio	0.65	0.55	0.68		0.57	0.56
Control Delay (s/veh)	24.5	6.6	21.0		35.8	10.2
Queue Delay	0.0	0.0	0.0		0.0	0.0
Total Delay (s/veh)	24.5	6.7	21.0		35.8	10.2
LOS	C	A	C		D	B
Approach Delay (s/veh)		15.2	21.0		16.8	
Approach LOS		B	C		B	

Intersection Summary

Area Type:	Other
Cycle Length:	90
Actuated Cycle Length:	64.8
Natural Cycle:	75
Control Type:	Actuated-Uncoordinated
Maximum v/c Ratio:	0.68
Intersection Signal Delay (s/veh):	17.2
Intersection LOS:	B
Intersection Capacity Utilization:	57.9%
ICU Level of Service:	B
Analysis Period (min):	15

Splits and Phases: 2: Shiloh Road & Hembree Ln



Lanes, Volumes, Timings  
 3: US 101 NB Off-Ramp & Shiloh Road

Existing Project Alter. B Conditions  
 Timing Plan: P.M. Peak

	→	↘	↙	←	↖	↗
Lane Group	EBT	EBR	WBL	WBT	NBL	NBR
Lane Configurations	↑↑			↑	↘	↗
Traffic Volume (vph)	482	0	0	722	526	807
Future Volume (vph)	482	0	0	722	526	807
Ideal Flow (vphpl)	1900	1900	1900	1900	1900	1900
Storage Length (ft)		0	0		0	265
Storage Lanes		0	0		1	2
Taper Length (ft)			25		25	
Lane Util. Factor	0.95	1.00	1.00	1.00	1.00	0.88
Frt						0.850
Flt Protected					0.950	
Satd. Flow (prot)	3539	0	0	1863	1770	2787
Flt Permitted					0.950	
Satd. Flow (perm)	3539	0	0	1863	1770	2787
Right Turn on Red		Yes				Yes
Satd. Flow (RTOR)						447
Link Speed (mph)	40			40	30	
Link Distance (ft)	186			371	769	
Travel Time (s)	3.2			6.3	17.5	
Peak Hour Factor	0.94	0.94	0.97	0.97	0.90	0.90
Adj. Flow (vph)	513	0	0	744	584	897
Shared Lane Traffic (%)						
Lane Group Flow (vph)	513	0	0	744	584	897
Enter Blocked Intersection	No	No	No	No	No	No
Lane Alignment	Left	Right	Left	Left	Left	Right
Median Width(ft)	0			0	12	
Link Offset(ft)	0			0	0	
Crosswalk Width(ft)	16			16	16	
Two way Left Turn Lane						
Headway Factor	1.00	1.00	1.00	1.00	1.00	1.00
Turning Speed (mph)		9	15		15	9
Number of Detectors	2			2	1	1
Detector Template	Thru			Thru	Left	Right
Leading Detector (ft)	100			100	20	20
Trailing Detector (ft)	0			0	0	0
Detector 1 Position(ft)	0			0	0	0
Detector 1 Size(ft)	6			6	20	20
Detector 1 Type	Cl+Ex			Cl+Ex	Cl+Ex	Cl+Ex
Detector 1 Channel						
Detector 1 Extend (s)	0.0			0.0	0.0	0.0
Detector 1 Queue (s)	0.0			0.0	0.0	0.0
Detector 1 Delay (s)	0.0			0.0	0.0	0.0
Detector 2 Position(ft)	94			94		
Detector 2 Size(ft)	6			6		
Detector 2 Type	Cl+Ex			Cl+Ex		
Detector 2 Channel						
Detector 2 Extend (s)	0.0			0.0		
Turn Type	NA			NA	Prot	Perm
Protected Phases	2			6	8	
Permitted Phases						8

Lanes, Volumes, Timings  
 3: US 101 NB Off-Ramp & Shiloh Road

Existing Project Alter. B Conditions  
 Timing Plan: P.M. Peak



Lane Group	EBT	EBR	WBL	WBT	NBL	NBR
Detector Phase	2			6	8	8
Switch Phase						
Minimum Initial (s)	5.0			5.0	5.0	5.0
Minimum Split (s)	9.0			9.0	9.0	9.0
Total Split (s)	37.0			37.0	35.0	35.0
Total Split (%)	51.4%			51.4%	48.6%	48.6%
Maximum Green (s)	33.0			33.0	31.0	31.0
Yellow Time (s)	3.0			3.0	3.0	3.0
All-Red Time (s)	1.0			1.0	1.0	1.0
Lost Time Adjust (s)	0.0			0.0	0.0	0.0
Total Lost Time (s)	4.0			4.0	4.0	4.0
Lead/Lag						
Lead-Lag Optimize?						
Vehicle Extension (s)	3.0			3.0	3.0	3.0
Recall Mode	None			None	None	None
Act Effect Green (s)	29.0			29.0	26.7	26.7
Actuated g/C Ratio	0.45			0.45	0.42	0.42
v/c Ratio	0.32			0.88	0.79	0.63
Control Delay (s/veh)	12.4			31.2	26.4	9.5
Queue Delay	0.0			0.0	0.0	0.0
Total Delay (s/veh)	12.4			31.2	26.4	9.5
LOS	B			C	C	A
Approach Delay (s/veh)	12.4			31.2	16.1	
Approach LOS	B			C	B	

Intersection Summary

Area Type: Other  
 Cycle Length: 72  
 Actuated Cycle Length: 64.1  
 Natural Cycle: 60  
 Control Type: Actuated-Uncoordinated  
 Maximum v/c Ratio: 0.88  
 Intersection Signal Delay (s/veh): 19.5  
 Intersection LOS: B  
 Intersection Capacity Utilization 119.5%  
 ICU Level of Service H  
 Analysis Period (min) 15

Splits and Phases: 3: US 101 NB Off-Ramp & Shiloh Road

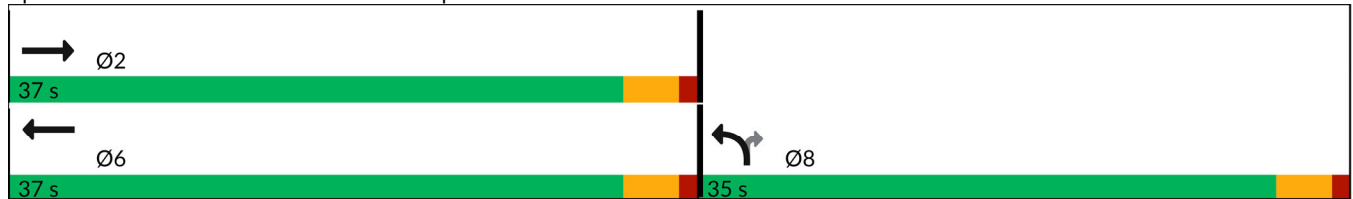

Lanes, Volumes, Timings  
4: Shiloh Road & US 101 SB Off-Ramp

Existing Project Alter. B Conditions  
Timing Plan: P.M. Peak

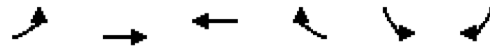

Lane Group	EBL	EBT	WBT	WBR	SBL	SBR
Lane Configurations		↑	↑		↓	↓
Traffic Volume (vph)	0	445	636	0	233	110
Future Volume (vph)	0	445	636	0	233	110
Ideal Flow (vphp)	1900	1900	1900	1900	1900	1900
Storage Length (ft)	0			0	0	275
Storage Lanes	0			0	1	1
Taper Length (ft)	25				25	
Lane Util. Factor	1.00	1.00	1.00	1.00	1.00	1.00
Ped Bike Factor						0.98
Frt						0.850
Flt Protected					0.950	
Satd. Flow (prot)	0	1863	1863	0	1770	1583
Flt Permitted					0.950	
Satd. Flow (perm)	0	1863	1863	0	1770	1548
Right Turn on Red				Yes		Yes
Satd. Flow (RTOR)						118
Link Speed (mph)		40	40		30	
Link Distance (ft)		225	306		486	
Travel Time (s)		3.8	5.2		11.0	
Confl. Peds. (#/hr)						1
Peak Hour Factor	0.89	0.89	0.96	0.96	0.93	0.93
Adj. Flow (vph)	0	500	663	0	251	118
Shared Lane Traffic (%)						
Lane Group Flow (vph)	0	500	663	0	251	118
Enter Blocked Intersection	No	No	No	No	No	No
Lane Alignment	Left	Left	Left	Right	Left	Right
Median Width(ft)		4	0		12	
Link Offset(ft)		0	0		0	
Crosswalk Width(ft)		16	16		16	
Two way Left Turn Lane						
Headway Factor	1.00	1.00	1.00	1.00	1.00	1.00
Turning Speed (mph)	15			9	15	9
Number of Detectors		2	2		1	1
Detector Template		Thru	Thru		Left	Right
Leading Detector (ft)		100	100		20	20
Trailing Detector (ft)		0	0		0	0
Detector 1 Position(ft)		0	0		0	0
Detector 1 Size(ft)		6	6		20	20
Detector 1 Type		Cl+Ex	Cl+Ex		Cl+Ex	Cl+Ex
Detector 1 Channel						
Detector 1 Extend (s)		0.0	0.0		0.0	0.0
Detector 1 Queue (s)		0.0	0.0		0.0	0.0
Detector 1 Delay (s)		0.0	0.0		0.0	0.0
Detector 2 Position(ft)		94	94			
Detector 2 Size(ft)		6	6			
Detector 2 Type		Cl+Ex	Cl+Ex			
Detector 2 Channel						
Detector 2 Extend (s)		0.0	0.0			
Turn Type		NA	NA		Perm	Perm

Lanes, Volumes, Timings  
4: Shiloh Road & US 101 SB Off-Ramp

Existing Project Alter. B Conditions  
Timing Plan: P.M. Peak

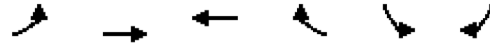

Lane Group	EBL	EBT	WBT	WBR	SBL	SBR
Protected Phases		2	6			
Permitted Phases					4	4
Detector Phase		2	6		4	4
Switch Phase						
Minimum Initial (s)		5.0	5.0		5.0	5.0
Minimum Split (s)		9.0	38.0		9.0	9.0
Total Split (s)		69.0	69.0		21.0	21.0
Total Split (%)		76.7%	76.7%		23.3%	23.3%
Maximum Green (s)		65.0	65.0		17.0	17.0
Yellow Time (s)		3.0	3.0		3.0	3.0
All-Red Time (s)		1.0	1.0		1.0	1.0
Lost Time Adjust (s)		0.0	0.0		0.0	0.0
Total Lost Time (s)		4.0	4.0		4.0	4.0
Lead/Lag						
Lead-Lag Optimize?						
Vehicle Extension (s)		3.0	3.0		3.0	3.0
Recall Mode		None	None		None	None
Walk Time (s)			7.0			
Flash Don't Walk (s)			27.0			
Pedestrian Calls (#/hr)			0			
Act Effct Green (s)		21.6	21.6		11.9	11.9
Actuated g/C Ratio		0.52	0.52		0.28	0.28
v/c Ratio		0.52	0.69		0.50	0.23
Control Delay (s/veh)		9.1	12.3		18.0	5.0
Queue Delay		0.0	0.0		0.0	0.0
Total Delay (s/veh)		9.1	12.3		18.0	5.0
LOS		A	B		B	A
Approach Delay (s/veh)		9.1	12.3		13.9	
Approach LOS		A	B		B	

Intersection Summary

Area Type:	Other
Cycle Length:	90
Actuated Cycle Length:	41.9
Natural Cycle:	55
Control Type:	Actuated-Uncoordinated
Maximum v/c Ratio:	0.69
Intersection Signal Delay (s/veh):	11.6
Intersection LOS:	B
Intersection Capacity Utilization:	113.7%
ICU Level of Service:	H
Analysis Period (min):	15

Splits and Phases: 4: Shiloh Road & US 101 SB Off-Ramp

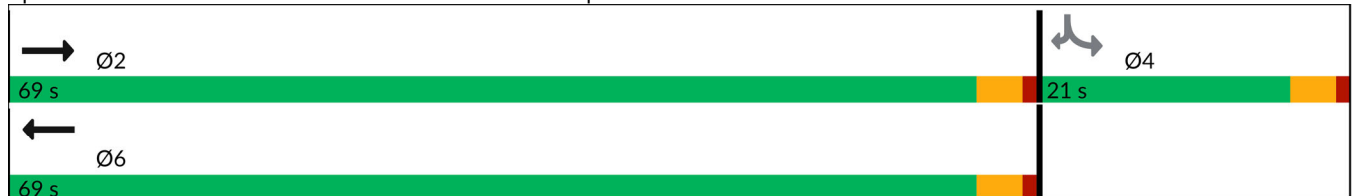



















Lanes, Volumes, Timings  
5: Caletti Ave & Shiloh Road

Existing Project Alter. B Conditions  
Timing Plan: P.M. Peak

	→	↘	↙	←	↖	↗
Lane Group	EBT	EBR	WBL	WBT	NBL	NBR
Lane Configurations	↑↑		↘	↑	↘	↗
Traffic Volume (vph)	873	28	79	672	15	149
Future Volume (vph)	873	28	79	672	15	149
Ideal Flow (vphpl)	1900	1900	1900	1900	1900	1900
Storage Length (ft)		0	68		0	0
Storage Lanes		0	1		1	1
Taper Length (ft)			50		25	
Lane Util. Factor	0.95	0.95	1.00	1.00	1.00	1.00
Frt	0.995					0.850
Flt Protected			0.950		0.950	
Satd. Flow (prot)	3522	0	1770	1863	1770	1583
Flt Permitted			0.950		0.950	
Satd. Flow (perm)	3522	0	1770	1863	1770	1583
Link Speed (mph)	40			40	30	
Link Distance (ft)	1081			184	459	
Travel Time (s)	18.4			3.1	10.4	
Peak Hour Factor	0.89	0.89	0.92	0.92	0.89	0.89
Adj. Flow (vph)	981	31	86	730	17	167
Shared Lane Traffic (%)						
Lane Group Flow (vph)	1012	0	86	730	17	167
Enter Blocked Intersection	No	No	No	No	No	No
Lane Alignment	Left	Right	Left	Left	Left	Right
Median Width(ft)	12			12	12	
Link Offset(ft)	0			0	0	
Crosswalk Width(ft)	16			16	16	
Two way Left Turn Lane						
Headway Factor	1.00	1.00	1.00	1.00	1.00	1.00
Turning Speed (mph)		9	15		15	9
Sign Control	Free			Free	Stop	
<b>Intersection Summary</b>						
Area Type:	Other					
Control Type:	Unsignalized					
Intersection Capacity Utilization	45.4%			ICU Level of Service A		
Analysis Period (min)	15					

Lanes, Volumes, Timings  
6: Conde Lane & Shiloh Road

Existing Project Alter. B Conditions  
Timing Plan: P.M. Peak

												
Lane Group	EBL	EBT	EBR	WBL	WBT	WBR	NBL	NBT	NBR	SBL	SBT	SBR
Lane Configurations												
Traffic Volume (vph)	69	492	2	7	477	289	5	3	17	297	0	39
Future Volume (vph)	69	492	2	7	477	289	5	3	17	297	0	39
Ideal Flow (vphpl)	1900	1900	1900	1900	1900	1900	1900	1900	1900	1900	1900	1900
Storage Length (ft)	90		0	127		0	0		0	0		40
Storage Lanes	1		0	1		0	0		0	0		1
Taper Length (ft)	70			40			25			25		
Lane Util. Factor	1.00	0.95	0.95	1.00	0.95	0.95	1.00	1.00	1.00	1.00	1.00	1.00
Ped Bike Factor	1.00				0.99							
Frt		0.999			0.943			0.909				0.850
Flt Protected	0.950			0.950				0.990			0.950	
Satd. Flow (prot)	1770	3536	0	1770	3311	0	0	1676	0	0	1770	1583
Flt Permitted	0.950			0.950				0.990			0.950	
Satd. Flow (perm)	1767	3536	0	1770	3311	0	0	1676	0	0	1770	1583
Right Turn on Red			Yes			Yes			Yes			No
Satd. Flow (RTOR)					132			27				
Link Speed (mph)		40			40			30				35
Link Distance (ft)		815			1081			418				522
Travel Time (s)		13.9			18.4			9.5				10.2
Confl. Peds. (#/hr)	1						1					
Peak Hour Factor	0.88	0.88	0.88	0.80	0.80	0.80	0.63	0.63	0.63	0.88	0.88	0.88
Adj. Flow (vph)	78	559	2	9	596	361	8	5	27	338	0	44
Shared Lane Traffic (%)												
Lane Group Flow (vph)	78	561	0	9	957	0	0	40	0	0	338	44
Enter Blocked Intersection	No	No	No	No	No	No	No	No	No	No	No	No
Lane Alignment	Left	Left	Right	Left	Left	Right	Left	Left	Right	Left	Left	Right
Median Width(ft)		12			12			0				0
Link Offset(ft)		0			0			0				0
Crosswalk Width(ft)		16			16			16				16
Two way Left Turn Lane												
Headway Factor	1.00	1.00	1.00	1.00	1.00	1.00	1.00	1.00	1.00	1.00	1.00	1.00
Turning Speed (mph)	15		9	15		9	15		9	15		9
Number of Detectors	1	2		1	2		1	2		1	1	1
Detector Template	Left	Thru		Left	Thru		Left	Thru		Left	Thru	Right
Leading Detector (ft)	20	100		20	100		20	100		20	30	20
Trailing Detector (ft)	0	0		0	0		0	0		0	0	0
Detector 1 Position(ft)	0	0		0	0		0	0		0	0	0
Detector 1 Size(ft)	20	6		20	6		20	6		20	30	20
Detector 1 Type	Cl+Ex	Cl+Ex		Cl+Ex	Cl+Ex		Cl+Ex	Cl+Ex		Cl+Ex	Cl+Ex	Cl+Ex
Detector 1 Channel												
Detector 1 Extend (s)	0.0	0.0		0.0	0.0		0.0	0.0		0.0	0.0	0.0
Detector 1 Queue (s)	0.0	0.0		0.0	0.0		0.0	0.0		0.0	0.0	0.0
Detector 1 Delay (s)	0.0	0.0		0.0	0.0		0.0	0.0		0.0	0.0	0.0
Detector 2 Position(ft)		94			94			94				
Detector 2 Size(ft)		6			6			6				
Detector 2 Type		Cl+Ex			Cl+Ex			Cl+Ex				
Detector 2 Channel												
Detector 2 Extend (s)		0.0			0.0			0.0				
Turn Type	Prot	NA		Prot	NA		Split	NA		Split	NA	custom



Lanes, Volumes, Timings  
6: Conde Lane & Shiloh Road

Existing Project Alter. B Conditions  
Timing Plan: P.M. Peak

Lane Group	EBL	EBT	EBR	WBL	WBT	WBR	NBL	NBT	NBR	SBL	SBT	SBR
Protected Phases	5	2		1	6		7	7		4	4	
Permitted Phases												6
Detector Phase	5	2		1	6		7	7		4	4	6
Switch Phase												
Minimum Initial (s)	8.0	8.0		8.0	8.0		10.0	10.0		11.0	11.0	8.0
Minimum Split (s)	12.0	46.0		12.0	12.0		37.0	37.0		15.0	15.0	12.0
Total Split (s)	13.0	46.0		12.0	45.0		37.0	37.0		15.0	15.0	45.0
Total Split (%)	11.8%	41.8%		10.9%	40.9%		33.6%	33.6%		13.6%	13.6%	40.9%
Maximum Green (s)	9.0	42.0		8.0	41.0		33.0	33.0		11.0	11.0	41.0
Yellow Time (s)	3.0	3.0		3.0	3.0		3.0	3.0		3.0	3.0	3.0
All-Red Time (s)	1.0	1.0		1.0	1.0		1.0	1.0		1.0	1.0	1.0
Lost Time Adjust (s)	0.0	0.0		0.0	0.0		0.0	0.0		0.0	0.0	0.0
Total Lost Time (s)	4.0	4.0		4.0	4.0		4.0	4.0		4.0	4.0	4.0
Lead/Lag	Lead	Lag		Lead	Lag							Lag
Lead-Lag Optimize?	Yes	Yes		Yes	Yes							Yes
Vehicle Extension (s)	3.0	3.0		3.0	3.0		3.0	3.0		3.0	3.0	3.0
Recall Mode	None	None		None	None		None	None		None	None	None
Walk Time (s)		7.0					7.0	7.0				
Flash Don't Walk (s)		35.0					26.0	26.0				
Pedestrian Calls (#/hr)		0					0	0				
Act Effct Green (s)	9.5	31.5		9.0	24.1			11.3			12.4	24.1
Actuated g/C Ratio	0.15	0.51		0.15	0.39			0.18			0.20	0.39
v/c Ratio	0.29	0.31		0.03	0.70			0.12			0.95	0.07
Control Delay (s/veh)	33.5	10.3		32.1	17.6			17.8			72.3	14.3
Queue Delay	0.0	0.0		0.0	0.0			0.0			0.0	0.0
Total Delay (s/veh)	33.5	10.3		32.1	17.6			17.8			72.3	14.3
LOS	C	B		C	B			B			E	B
Approach Delay (s/veh)		13.1			17.8			17.8			65.6	
Approach LOS		B			B			B			E	

Intersection Summary

Area Type:	Other
Cycle Length:	110
Actuated Cycle Length:	61.7
Natural Cycle:	120
Control Type:	Actuated-Uncoordinated
Maximum v/c Ratio:	0.95
Intersection Signal Delay (s/veh):	25.3
Intersection LOS:	C
Intersection Capacity Utilization:	62.3%
ICU Level of Service:	B
Analysis Period (min):	15

Splits and Phases: 6: Conde Lane & Shiloh Road



Lanes, Volumes, Timings  
7: Driveway 1/Gridley Drive & Shiloh Road



















Existing Project Alter. B Conditions  
Timing Plan: P.M. Peak

Lane Group	EBL	EBT	EBR	WBL	WBT	WBR	NBL	NBT	NBR	SBL	SBT	SBR
Lane Configurations												
Traffic Volume (vph)	17	336	76	0	341	0	71	0	0	0	0	14
Future Volume (vph)	17	336	76	0	341	0	71	0	0	0	0	14
Ideal Flow (vphpl)	1900	1900	1900	1900	1900	1900	1900	1900	1900	1900	1900	1900
Storage Length (ft)	0		150	0		0	0		0	0		0
Storage Lanes	0		1	0		0	1		0	0		0
Taper Length (ft)	25			25			25			25		
Lane Util. Factor	1.00	1.00	1.00	1.00	1.00	1.00	1.00	1.00	1.00	1.00	1.00	1.00
Ped Bike Factor												
Frt			0.850									0.865
Flt Protected		0.998					0.950					
Satd. Flow (prot)	0	1859	1583	0	1863	0	1770	1863	0	0	1611	0
Flt Permitted		0.998					0.950					
Satd. Flow (perm)	0	1859	1583	0	1863	0	1770	1863	0	0	1611	0
Link Speed (mph)		40			40			30			30	
Link Distance (ft)		608			2146			248			715	
Travel Time (s)		10.4			36.6			5.6			16.3	
Confl. Peds. (#/hr)	1											
Confl. Bikes (#/hr)			1									
Peak Hour Factor	0.94	0.94	0.94	0.69	0.69	0.69	1.00	1.00	1.00	0.58	0.58	0.58
Adj. Flow (vph)	18	357	81	0	494	0	71	0	0	0	0	24
Shared Lane Traffic (%)												
Lane Group Flow (vph)	0	375	81	0	494	0	71	0	0	0	24	0
Enter Blocked Intersection	No	No	No	No	No	No	No	No	No	No	No	No
Lane Alignment	Left	Left	Right	Left	Left	Right	Left	Left	Right	Left	Left	Right
Median Width(ft)		0			0			12			12	
Link Offset(ft)		0			0			0			0	
Crosswalk Width(ft)		16			16			16			16	
Two way Left Turn Lane												
Headway Factor	1.00	1.00	1.00	1.00	1.00	1.00	1.00	1.00	1.00	1.00	1.00	1.00
Turning Speed (mph)	15		9	15		9	15		9	15		9
Sign Control		Free			Free			Stop			Stop	

Intersection Summary	
Area Type:	Other
Control Type:	Unsignalized
Intersection Capacity Utilization	48.8%
Analysis Period (min)	15
	ICU Level of Service A

Lanes, Volumes, Timings  
8: Old Redwood Hwy & Driveway 2

Existing Project Alter. B Conditions  
Timing Plan: P.M. Peak

												
Lane Group	EBL	EBT	EBR	WBL	WBT	WBR	NBL	NBT	NBR	SBL	SBT	SBR
Lane Configurations												
Traffic Volume (vph)	3	0	0	41	0	66	0	505	45	72	427	0
Future Volume (vph)	3	0	0	41	0	66	0	505	45	72	427	0
Ideal Flow (vphp)	1900	1900	1900	1900	1900	1900	1900	1900	1900	1900	1900	1900
Storage Length (ft)	0		0	0		0	0		100	50		0
Storage Lanes	0		0	1		0	0		1	1		0
Taper Length (ft)	25			25			25			25		
Lane Util. Factor	1.00	1.00	1.00	1.00	1.00	1.00	1.00	1.00	1.00	1.00	1.00	1.00
Ped Bike Factor												
Frt					0.850				0.850			
Flt Protected		0.950		0.950						0.950		
Satd. Flow (prot)	0	1770	0	1770	1583	0	0	1863	1583	1770	1863	0
Flt Permitted		0.950		0.950						0.950		
Satd. Flow (perm)	0	1770	0	1770	1583	0	0	1863	1583	1770	1863	0
Link Speed (mph)		30			30			45			45	
Link Distance (ft)		98			385			520			748	
Travel Time (s)		2.2			8.8			7.9			11.3	
Confl. Bikes (#/hr)									3			5
Peak Hour Factor	0.38	0.38	0.38	1.00	1.00	1.00	0.91	0.91	0.91	0.94	0.94	0.94
Adj. Flow (vph)	8	0	0	41	0	66	0	555	49	77	454	0
Shared Lane Traffic (%)												
Lane Group Flow (vph)	0	8	0	41	66	0	0	555	49	77	454	0
Enter Blocked Intersection	No	No	No	No	No	No	No	No	No	No	No	No
Lane Alignment	Left	Left	Right	Left	Left	Right	Left	Left	Right	Left	Left	Right
Median Width(ft)		12			12			12			12	
Link Offset(ft)		0			0			0			0	
Crosswalk Width(ft)		16			16			16			16	
Two way Left Turn Lane												
Headway Factor	1.00	1.00	1.00	1.00	1.00	1.00	1.00	1.00	1.00	1.00	1.00	1.00
Turning Speed (mph)	15		9	15		9	15		9	15		9
Sign Control		Stop			Stop			Free			Free	
<b>Intersection Summary</b>												
Area Type:	Other											
Control Type:	Unsignalized											
Intersection Capacity Utilization	63.1%						ICU Level of Service B					
Analysis Period (min)	15											

Lanes, Volumes, Timings  
 9: Driveway 3 & Shiloh Road

Existing Project Alter. B Conditions

Timing Plan: P.M. Peak

	→	↘	↙	←	↖	↗
Lane Group	EBT	EBR	WBL	WBT	NBL	NBR
Lane Configurations	↑	↗		↖	↘	↗
Traffic Volume (vph)	81	233	22	111	216	21
Future Volume (vph)	81	233	22	111	216	21
Ideal Flow (vphpl)	1900	1900	1900	1900	1900	1900
Storage Length (ft)		200	0		0	0
Storage Lanes		1	0		1	1
Taper Length (ft)			25		25	
Lane Util. Factor	1.00	1.00	1.00	1.00	1.00	1.00
Frt		0.850				0.850
Flt Protected				0.992	0.950	
Satd. Flow (prot)	1863	1583	0	1848	1770	1583
Flt Permitted				0.992	0.950	
Satd. Flow (perm)	1863	1583	0	1848	1770	1583
Link Speed (mph)	40			40	30	
Link Distance (ft)	2146			134	402	
Travel Time (s)	36.6			2.3	9.1	
Peak Hour Factor	0.92	0.92	0.68	0.68	1.00	1.00
Adj. Flow (vph)	88	253	32	163	216	21
Shared Lane Traffic (%)						
Lane Group Flow (vph)	88	253	0	195	216	21
Enter Blocked Intersection	No	No	No	No	No	No
Lane Alignment	Left	Right	Left	Left	Left	Right
Median Width(ft)	0			0	12	
Link Offset(ft)	0			0	0	
Crosswalk Width(ft)	16			16	16	
Two way Left Turn Lane						
Headway Factor	1.00	1.00	1.00	1.00	1.00	1.00
Turning Speed (mph)		9	15		15	9
Sign Control	Free			Free	Stop	

Intersection Summary

Area Type:	Other
Control Type:	Unsignalized
Intersection Capacity Utilization	32.4%
ICU Level of Service	A
Analysis Period (min)	15

Lanes, Volumes, Timings

Existing Project Alter. B Conditions

10: US 101 NB Off Ramp/Lakewood Drive & Old Redwood Highway

Timing Plan: P.M. Peak



Lane Group	EBL	EBT	EBR	WBL	WBT	WBR	NBL	NBT	NBR	SBL	SBT	SBR
Lane Configurations												
Traffic Volume (vph)	261	395	0	0	538	192	500	412	251	249	0	577
Future Volume (vph)	261	395	0	0	538	192	500	412	251	249	0	577
Ideal Flow (vphpl)	1900	1900	1900	1900	1900	1900	1900	1900	1900	1900	1900	1900
Storage Length (ft)	155		0	0		0	270		150	120		0
Storage Lanes	1		0	0		0	1		1	1		1
Taper Length (ft)	50			25			165			75		
Lane Util. Factor	0.97	1.00	1.00	1.00	0.95	0.95	0.91	0.91	0.95	0.97	1.00	1.00
Ped Bike Factor	1.00				0.99			0.99		1.00		
Fr <sub>t</sub>					0.961			0.951				0.850
Fl <sub>t</sub> Protected	0.950						0.950	0.993		0.950		
Satd. Flow (prot)	3433	1863	0	0	3382	0	1610	3181	0	3433	0	1583
Fl <sub>t</sub> Permitted	0.950						0.950	0.993		0.950		
Satd. Flow (perm)	3427	1863	0	0	3382	0	1610	3181	0	3420	0	1583
Right Turn on Red			Yes			Yes			Yes			Yes
Satd. Flow (RTOR)					57			85				286
Link Speed (mph)		35			35			30				30
Link Distance (ft)		226			617			716				478
Travel Time (s)		4.4			12.0			16.3				10.9
Confl. Peds. (#/hr)	3		1	1		3			8	8		
Confl. Bikes (#/hr)			2			9						
Peak Hour Factor	0.87	0.87	0.87	0.91	0.91	0.91	0.92	0.92	0.92	0.96	0.96	0.96
Adj. Flow (vph)	300	454	0	0	591	211	543	448	273	259	0	601
Shared Lane Traffic (%)							22%					
Lane Group Flow (vph)	300	454	0	0	802	0	424	840	0	259	0	601
Enter Blocked Intersection	No	No	No	No	No	No	No	No	No	No	No	No
Lane Alignment	Left	Left	Right	Left	Left	Right	Left	Left	Right	Left	Left	Right
Median Width(ft)		24			24			24				24
Link Offset(ft)		0			0			0				0
Crosswalk Width(ft)		16			16			16				16
Two way Left Turn Lane												
Headway Factor	1.00	1.00	1.00	1.00	1.00	1.00	1.00	1.00	1.00	1.00	1.00	1.00
Turning Speed (mph)	15		9	15		9	15		9	15		9
Number of Detectors	1	2			2		1	2		1		1
Detector Template	Left	Thru			Thru		Left	Thru		Left		Right
Leading Detector (ft)	20	100			100		20	100		20		20
Trailing Detector (ft)	0	0			0		0	0		0		0
Detector 1 Position(ft)	0	0			0		0	0		0		0
Detector 1 Size(ft)	20	6			6		20	6		20		20
Detector 1 Type	Cl+Ex	Cl+Ex			Cl+Ex		Cl+Ex	Cl+Ex		Cl+Ex		Cl+Ex
Detector 1 Channel												
Detector 1 Extend (s)	0.0	0.0			0.0		0.0	0.0		0.0		0.0
Detector 1 Queue (s)	0.0	0.0			0.0		0.0	0.0		0.0		0.0
Detector 1 Delay (s)	0.0	0.0			0.0		0.0	0.0		0.0		0.0
Detector 2 Position(ft)		94			94			94				
Detector 2 Size(ft)		6			6			6				
Detector 2 Type		Cl+Ex			Cl+Ex			Cl+Ex				
Detector 2 Channel												
Detector 2 Extend (s)		0.0			0.0			0.0				

Lanes, Volumes, Timings

Existing Project Alter. B Conditions

10: US 101 NB Off Ramp/Lakewood Drive & Old Redwood Highway

Timing Plan: P.M. Peak



Lane Group	EBL	EBT	EBR	WBL	WBT	WBR	NBL	NBT	NBR	SBL	SBT	SBR
Turn Type	Prot	NA			NA		Split	NA		Prot		pm+ov
Protected Phases	5	2			6		8	8		7		5
Permitted Phases												5 8
Detector Phase	5	2			6		8	8		7		5
Switch Phase												
Minimum Initial (s)	7.0	10.0			10.0		10.0	10.0		7.0		7.0
Minimum Split (s)	11.0	32.1			32.1		33.7	33.7		11.0		11.0
Total Split (s)	13.0	45.3			32.3		33.7	33.7		11.0		13.0
Total Split (%)	14.4%	50.3%			35.9%		37.4%	37.4%		12.2%		14.4%
Maximum Green (s)	9.0	40.2			27.2		29.0	29.0		7.0		9.0
Yellow Time (s)	3.0	4.1			4.1		3.7	3.7		3.0		3.0
All-Red Time (s)	1.0	1.0			1.0		1.0	1.0		1.0		1.0
Lost Time Adjust (s)	0.0	0.0			0.0		0.0	0.0		0.0		0.0
Total Lost Time (s)	4.0	5.1			5.1		4.7	4.7		4.0		4.0
Lead/Lag	Lead				Lag		Lag	Lag		Lead		Lead
Lead-Lag Optimize?	Yes				Yes		Yes	Yes		Yes		Yes
Vehicle Extension (s)	3.0	3.0			3.0		3.0	3.0		3.0		3.0
Recall Mode	None	Max			Max		None	None		None		None
Walk Time (s)		7.0			7.0		7.0	7.0				
Flash Don't Walk (s)		20.0			17.0		22.0	22.0				
Pedestrian Calls (#/hr)		0			0		0	0				
Act Effct Green (s)	9.0	40.2			27.2		27.5	27.5		7.0		41.2
Actuated g/C Ratio	0.10	0.45			0.31		0.31	0.31		0.08		0.47
v/c Ratio	0.86	0.54			0.74		0.85	0.80		0.95		0.68
Control Delay (s/veh)	64.1	20.8			30.8		46.2	31.9		87.1		13.4
Queue Delay	0.0	0.0			0.0		0.0	0.0		0.0		0.0
Total Delay (s/veh)	64.1	20.8			30.8		46.2	31.9		87.1		13.4
LOS	E	C			C		D	C		F		B
Approach Delay (s/veh)		38.0			30.8			36.7				35.6
Approach LOS		D			C			D				D

Intersection Summary

Area Type: Other  
 Cycle Length: 90  
 Actuated Cycle Length: 88.5  
 Natural Cycle: 90  
 Control Type: Actuated-Uncoordinated  
 Maximum v/c Ratio: 0.95  
 Intersection Signal Delay (s/veh): 35.4  
 Intersection LOS: D  
 Intersection Capacity Utilization 91.5%  
 ICU Level of Service F  
 Analysis Period (min) 15

Splits and Phases: 10: US 101 NB Off Ramp/Lakewood Drive & Old Redwood Highway

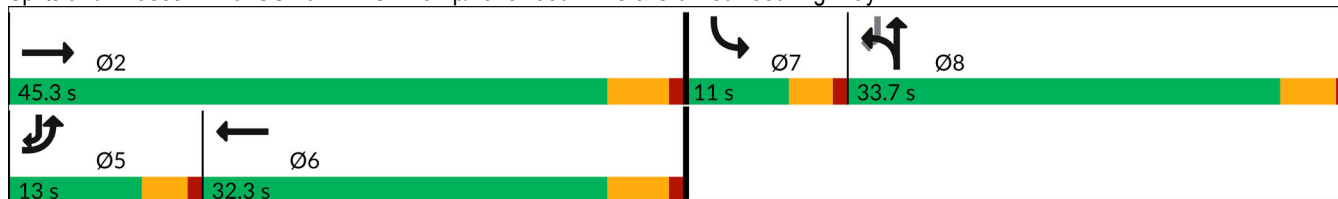

Lanes, Volumes, Timings  
 11: Old Redwood Highway & US 101 NB On Ramp

Existing Project Alter. B Conditions

Timing Plan: P.M. Peak

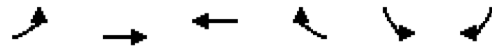

Lane Group	EBL	EBT	WBT	WBR	SBL	SBR
Lane Configurations	↶	↷	↶	↷		
Traffic Volume (vph)	106	650	1403	169	0	0
Future Volume (vph)	106	650	1403	169	0	0
Ideal Flow (vphp)	1900	1900	1900	1900	1900	1900
Storage Length (ft)	245			0	0	0
Storage Lanes	1			0	0	0
Taper Length (ft)	50				25	
Lane Util. Factor	1.00	0.95	0.95	0.95	1.00	1.00
Ped Bike Factor						
Frt			0.984			
Flt Protected	0.950					
Satd. Flow (prot)	1770	3539	3483	0	0	0
Flt Permitted	0.950					
Satd. Flow (perm)	1770	3539	3483	0	0	0
Link Speed (mph)		35	35		30	
Link Distance (ft)		531	226		299	
Travel Time (s)		10.3	4.4		6.8	
Confl. Peds. (#/hr)	17			17		
Confl. Bikes (#/hr)				8		
Peak Hour Factor	0.85	0.85	0.91	0.91	0.25	0.25
Adj. Flow (vph)	125	765	1542	186	0	0
Shared Lane Traffic (%)						
Lane Group Flow (vph)	125	765	1728	0	0	0
Enter Blocked Intersection	No	No	No	No	No	No
Lane Alignment	Left	Left	Left	Right	Left	Right
Median Width(ft)		12	12		0	
Link Offset(ft)		0	0		0	
Crosswalk Width(ft)		16	16		16	
Two way Left Turn Lane						
Headway Factor	1.00	1.00	1.00	1.00	1.00	1.00
Turning Speed (mph)	15			9	15	9
Sign Control		Free	Free		Free	

Intersection Summary

Area Type:	Other
Control Type:	Unsignalized
Intersection Capacity Utilization	66.2%
Analysis Period (min)	15
	ICU Level of Service C

Lanes, Volumes, Timings

Existing Project Alter. B Conditions

12: US 101 SB On Ramp/US 101 SB Off Ramp & Old Redwood Highway

Timing Plan: P.M. Peak



Lane Group	EBL	EBT	EBR	WBL	WBT	WBR	NBL	NBT	NBR	SBL	SBT	SBR
Lane Configurations		↑↑	↗	↘	↑↑					↘	↕	
Traffic Volume (vph)	0	535	381	381	1024	0	0	0	0	212	0	129
Future Volume (vph)	0	535	381	381	1024	0	0	0	0	212	0	129
Ideal Flow (vphpl)	1900	1900	1900	1900	1900	1900	1900	1900	1900	1900	1900	1900
Storage Length (ft)	0		0	250		0	0		0	420		0
Storage Lanes	0		1	0		0	0		0	1		0
Taper Length (ft)	25			165			25			75		
Lane Util. Factor	1.00	0.95	1.00	1.00	0.95	1.00	1.00	1.00	1.00	0.95	0.95	1.00
Ped Bike Factor			0.98	1.00								
Frt			0.850								0.881	
Flt Protected				0.950						0.950	0.990	
Satd. Flow (prot)	0	3539	1583	1770	3539	0	0	0	0	1681	1543	0
Flt Permitted				0.950						0.950	0.990	
Satd. Flow (perm)	0	3539	1558	1768	3539	0	0	0	0	1681	1543	0
Right Turn on Red			Yes			Yes			Yes			Yes
Satd. Flow (RTOR)			405								121	
Link Speed (mph)		35			35			30			30	
Link Distance (ft)		423			531			621			831	
Travel Time (s)		8.2			10.3			14.1			18.9	
Confl. Peds. (#/hr)	19		2	2		18						
Confl. Bikes (#/hr)			4			2						
Peak Hour Factor	0.94	0.94	0.94	0.89	0.89	0.89	0.25	0.25	0.25	0.83	0.83	0.83
Adj. Flow (vph)	0	569	405	428	1151	0	0	0	0	255	0	155
Shared Lane Traffic (%)										16%		
Lane Group Flow (vph)	0	569	405	428	1151	0	0	0	0	214	196	0
Enter Blocked Intersection	No	No	No	No	No	No	No	No	No	No	No	No
Lane Alignment	Left	Left	Right	Left	Left	Right	Left	Left	Right	Left	Left	Right
Median Width(ft)		24			24			12			12	
Link Offset(ft)		0			0			0			0	
Crosswalk Width(ft)		16			16			16			16	
Two way Left Turn Lane												
Headway Factor	1.00	1.00	1.00	1.00	1.00	1.00	1.00	1.00	1.00	1.00	1.00	1.00
Turning Speed (mph)	15		9	15		9	15		9	15		9
Number of Detectors		2	1	1	2					1	2	
Detector Template		Thru	Right	Left	Thru					Left	Thru	
Leading Detector (ft)		100	20	20	100					20	100	
Trailing Detector (ft)		0	0	0	0					0	0	
Detector 1 Position(ft)		0	0	0	0					0	0	
Detector 1 Size(ft)		6	20	20	6					20	6	
Detector 1 Type		Cl+Ex	Cl+Ex	Cl+Ex	Cl+Ex					Cl+Ex	Cl+Ex	
Detector 1 Channel												
Detector 1 Extend (s)		0.0	0.0	0.0	0.0					0.0	0.0	
Detector 1 Queue (s)		0.0	0.0	0.0	0.0					0.0	0.0	
Detector 1 Delay (s)		0.0	0.0	0.0	0.0					0.0	0.0	
Detector 2 Position(ft)		94			94							94
Detector 2 Size(ft)		6			6							6
Detector 2 Type		Cl+Ex			Cl+Ex							Cl+Ex
Detector 2 Channel												
Detector 2 Extend (s)		0.0			0.0							0.0



Lanes, Volumes, Timings

Existing Project Alter. B Conditions

12: US 101 SB On Ramp/US 101 SB Off Ramp & Old Redwood Highway

Timing Plan: P.M. Peak



Lane Group	EBL	EBT	EBR	WBL	WBT	WBR	NBL	NBT	NBR	SBL	SBT	SBR
Turn Type		NA	Perm	Prot	NA					Perm	NA	
Protected Phases		6		5	2						8	
Permitted Phases			6							8		
Detector Phase		6	6	5	2					8	8	
Switch Phase												
Minimum Initial (s)		10.0	10.0	7.0	10.0					10.0	10.0	
Minimum Split (s)		32.1	32.1	11.0	38.1					14.7	14.7	
Total Split (s)		33.0	33.0	22.0	55.0					15.0	15.0	
Total Split (%)		47.1%	47.1%	31.4%	78.6%					21.4%	21.4%	
Maximum Green (s)		27.9	27.9	18.0	49.9					10.3	10.3	
Yellow Time (s)		4.1	4.1	3.0	4.1					3.7	3.7	
All-Red Time (s)		1.0	1.0	1.0	1.0					1.0	1.0	
Lost Time Adjust (s)		0.0	0.0	0.0	0.0					0.0	0.0	
Total Lost Time (s)		5.1	5.1	4.0	5.1					4.7	4.7	
Lead/Lag		Lag	Lag	Lead								
Lead-Lag Optimize?		Yes	Yes	Yes								
Vehicle Extension (s)		3.0	3.0	3.0	3.0					3.0	3.0	
Recall Mode		Max	Max	None	Max					None	None	
Walk Time (s)		7.0	7.0		7.0							
Flash Don't Walk (s)		20.0	20.0		25.0							
Pedestrian Calls (#/hr)		0	0		0							
Act Effct Green (s)		27.9	27.9	18.0	49.9					10.3	10.3	
Actuated g/C Ratio		0.40	0.40	0.26	0.71					0.15	0.15	
v/c Ratio		0.40	0.47	0.94	0.46					0.87	0.59	
Control Delay (s/veh)		16.2	3.7	58.2	5.0					63.8	20.1	
Queue Delay		0.0	0.0	0.0	0.0					0.0	0.0	
Total Delay (s/veh)		16.2	3.7	58.2	5.0					63.8	20.1	
LOS		B	A	E	A					E	C	
Approach Delay (s/veh)		11.0			19.4						42.9	
Approach LOS		B			B						D	

Intersection Summary





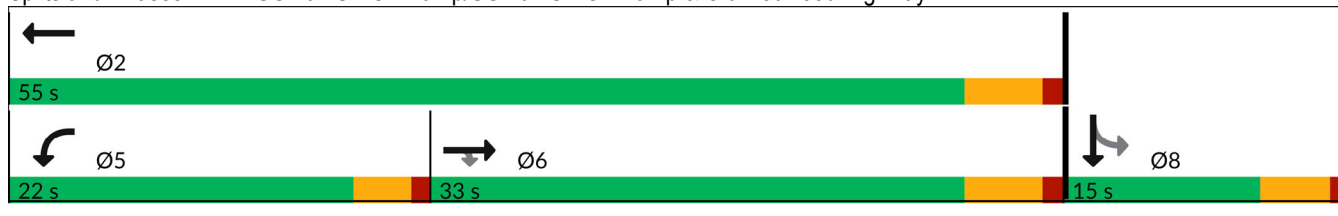

















Area Type: Other  
 Cycle Length: 70  
 Actuated Cycle Length: 70  
 Natural Cycle: 70  
 Control Type: Actuated-Uncoordinated  
 Maximum v/c Ratio: 0.94  
 Intersection Signal Delay (s/veh): 19.9  
 Intersection LOS: B  
 Intersection Capacity Utilization 66.2%  
 ICU Level of Service C  
 Analysis Period (min) 15

Splits and Phases: 12: US 101 SB On Ramp/US 101 SB Off Ramp & Old Redwood Highway



Lanes, Volumes, Timings  
1: Old Redwood Hwy & Shiloh Road

Existing Project Alter. B Conditions  
Timing Plan: Saturday Midday Peak

												
Lane Group	EBL	EBT	EBR	WBL	WBT	WBR	NBL	NBT	NBR	SBL	SBT	SBR
Lane Configurations												
Traffic Volume (vph)	123	441	231	21	476	69	243	242	24	69	196	180
Future Volume (vph)	123	441	231	21	476	69	243	242	24	69	196	180
Ideal Flow (vphpl)	1900	1900	1900	1900	1900	1900	1900	1900	1900	1900	1900	1900
Storage Length (ft)	375		140	0		50	200		98	130		93
Storage Lanes	1		1	0		1	1		1	1		1
Taper Length (ft)	50			25			60			93		
Lane Util. Factor	1.00	1.00	1.00	1.00	1.00	1.00	1.00	1.00	1.00	1.00	1.00	1.00
Ped Bike Factor	1.00		0.98						0.98			0.97
Frt			0.850			0.850			0.850			0.850
Flt Protected	0.950				0.998		0.950			0.950		
Satd. Flow (prot)	1770	1863	1583	0	1859	1583	1770	1863	1583	1770	1863	1583
Flt Permitted	0.950				0.998		0.950			0.950		
Satd. Flow (perm)	1764	1863	1549	0	1859	1583	1770	1863	1550	1770	1863	1540
Right Turn on Red			Yes			Yes			Yes			Yes
Satd. Flow (RTOR)			119			105			77			156
Link Speed (mph)		40			40			45			40	
Link Distance (ft)		1789			608			748			775	
Travel Time (s)		30.5			10.4			11.3			13.2	
Confl. Peds. (#/hr)	4											
Confl. Bikes (#/hr)			1						1			5
Peak Hour Factor	0.89	0.89	0.89	0.86	0.86	0.86	0.93	0.93	0.93	0.91	0.91	0.91
Adj. Flow (vph)	138	496	260	24	553	80	261	260	26	76	215	198
Shared Lane Traffic (%)												
Lane Group Flow (vph)	138	496	260	0	577	80	261	260	26	76	215	198
Enter Blocked Intersection	No	No	No	No	No	No	No	No	No	No	No	No
Lane Alignment	Left	Left	Right	Left	Left	Right	Left	Left	Right	Left	Left	Right
Median Width(ft)		12			12			12			12	
Link Offset(ft)		0			0			0			0	
Crosswalk Width(ft)		16			16			16			16	
Two way Left Turn Lane												
Headway Factor	1.00	1.00	1.00	1.00	1.00	1.00	1.00	1.00	1.00	1.00	1.00	1.00
Turning Speed (mph)	15		9	15		9	15		9	15		9
Number of Detectors	1	2	1	1	2	1	1	2	1	1	2	1
Detector Template	Left	Thru	Right	Left	Thru	Right	Left	Thru	Right	Left	Thru	Right
Leading Detector (ft)	20	100	20	20	100	20	20	100	20	20	100	20
Trailing Detector (ft)	0	0	0	0	0	0	0	0	0	0	0	0
Detector 1 Position(ft)	0	0	0	0	0	0	0	0	0	0	0	0
Detector 1 Size(ft)	20	6	20	20	6	20	20	6	20	20	6	20
Detector 1 Type	Cl+Ex	Cl+Ex	Cl+Ex	Cl+Ex	Cl+Ex	Cl+Ex	Cl+Ex	Cl+Ex	Cl+Ex	Cl+Ex	Cl+Ex	Cl+Ex
Detector 1 Channel												
Detector 1 Extend (s)	0.0	0.0	0.0	0.0	0.0	0.0	0.0	0.0	0.0	0.0	0.0	0.0
Detector 1 Queue (s)	0.0	0.0	0.0	0.0	0.0	0.0	0.0	0.0	0.0	0.0	0.0	0.0
Detector 1 Delay (s)	0.0	0.0	0.0	0.0	0.0	0.0	0.0	0.0	0.0	0.0	0.0	0.0
Detector 2 Position(ft)		94			94			94			94	
Detector 2 Size(ft)		6			6			6			6	
Detector 2 Type		Cl+Ex			Cl+Ex			Cl+Ex			Cl+Ex	
Detector 2 Channel												
Detector 2 Extend (s)		0.0			0.0			0.0			0.0	

Lanes, Volumes, Timings  
1: Old Redwood Hwy & Shiloh Road

Existing Project Alter. B Conditions  
Timing Plan: Saturday Midday Peak

Lane Group	EBL	EBT	EBR	WBL	WBT	WBR	NBL	NBT	NBR	SBL	SBT	SBR
Turn Type	Split	NA	Perm	Split	NA	Perm	Prot	NA	Perm	Prot	NA	Perm
Protected Phases	2	2		6	6		3	8		7	4	
Permitted Phases			2			6			8			4
Detector Phase	2	2	2	6	6	6	3	8	8	7	4	4
Switch Phase												
Minimum Initial (s)	5.0	5.0	5.0	5.0	5.0	5.0	5.0	5.0	5.0	5.0	5.0	5.0
Minimum Split (s)	34.5	34.5	34.5	42.5	42.5	42.5	8.5	46.5	46.5	8.5	39.5	39.5
Total Split (s)	35.0	35.0	35.0	42.5	42.5	42.5	18.0	48.0	48.0	9.5	39.5	39.5
Total Split (%)	25.9%	25.9%	25.9%	31.5%	31.5%	31.5%	13.3%	35.6%	35.6%	7.0%	29.3%	29.3%
Maximum Green (s)	30.5	30.5	30.5	38.0	38.0	38.0	14.5	43.5	43.5	6.0	35.0	35.0
Yellow Time (s)	3.5	3.5	3.5	3.5	3.5	3.5	3.0	3.5	3.5	3.0	3.5	3.5
All-Red Time (s)	1.0	1.0	1.0	1.0	1.0	1.0	0.5	1.0	1.0	0.5	1.0	1.0
Lost Time Adjust (s)	0.0	0.0	0.0		0.0	0.0	0.0	0.0	0.0	0.0	0.0	0.0
Total Lost Time (s)	4.5	4.5	4.5		4.5	4.5	3.5	4.5	4.5	3.5	4.5	4.5
Lead/Lag	Lead	Lead	Lead	Lag	Lag	Lag	Lead	Lag	Lag	Lead	Lag	Lag
Lead-Lag Optimize?	Yes	Yes	Yes	Yes	Yes	Yes	Yes	Yes	Yes	Yes	Yes	Yes
Vehicle Extension (s)	3.0	3.0	3.0	3.0	3.0	3.0	3.0	3.0	3.0	3.0	3.0	3.0
Recall Mode	None	None	None	None	None	None	None	None	None	None	None	None
Walk Time (s)	7.0	7.0	7.0	7.0	7.0	7.0		7.0	7.0		7.0	7.0
Flash Don't Walk (s)	23.0	23.0	23.0	31.0	31.0	31.0		35.0	35.0		28.0	28.0
Pedestrian Calls (#/hr)	0	0	0	0	0	0		0	0		0	0
Act Effct Green (s)	30.5	30.5	30.5		38.1	38.1	14.5	27.6	27.6	6.0	19.0	19.0
Actuated g/C Ratio	0.26	0.26	0.26		0.32	0.32	0.12	0.23	0.23	0.05	0.16	0.16
v/c Ratio	0.30	1.04	0.54		0.97	0.14	1.21	0.60	0.06	0.85	0.72	0.53
Control Delay (s/veh)	39.2	95.7	25.5		71.9	3.5	175.2	47.1	0.3	119.3	61.7	16.8
Queue Delay	0.0	0.0	0.0		0.0	0.0	0.0	0.0	0.0	0.0	0.0	0.0
Total Delay (s/veh)	39.2	95.7	25.5		71.9	3.5	175.2	47.1	0.3	119.3	61.7	16.8
LOS	D	F	C		E	A	F	D	A	F	E	B
Approach Delay (s/veh)		66.6			63.6			106.0			52.5	
Approach LOS		E			E			F			D	

Intersection Summary

Area Type: Other  
 Cycle Length: 135  
 Actuated Cycle Length: 119.2  
 Natural Cycle: 145  
 Control Type: Actuated-Uncoordinated  
 Maximum v/c Ratio: 1.21  
 Intersection Signal Delay (s/veh): 71.5  
 Intersection LOS: E  
 Intersection Capacity Utilization 87.8%  
 ICU Level of Service E  
 Analysis Period (min) 15

Splits and Phases: 1: Old Redwood Hwy & Shiloh Road

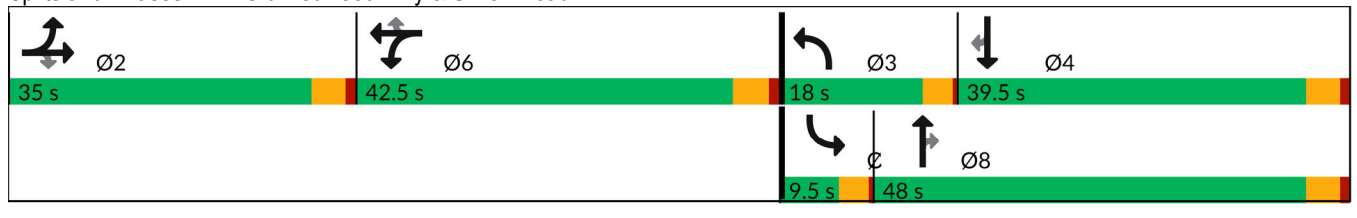

Lanes, Volumes, Timings  
2: Shiloh Road & Hembree Ln

Existing Project Alter. B Conditions  
Timing Plan: Saturday Midday Peak

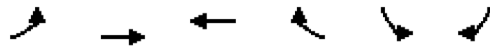

Lane Group	EBL	EBT	WBT	WBR	SBL	SBR
Lane Configurations	↙↘	↑	↕↔		↙	↗
Traffic Volume (vph)	622	707	700	159	160	580
Future Volume (vph)	622	707	700	159	160	580
Ideal Flow (vphp)	1900	1900	1900	1900	1900	1900
Storage Length (ft)	0			130	0	0
Storage Lanes	2			1	1	1
Taper Length (ft)	25				25	
Lane Util. Factor	0.97	1.00	0.95	0.95	1.00	1.00
Ped Bike Factor	1.00		1.00			
Frt			0.972			0.850
Flt Protected	0.950				0.950	
Satd. Flow (prot)	3433	1863	3432	0	1770	1583
Flt Permitted	0.950				0.950	
Satd. Flow (perm)	3432	1863	3432	0	1770	1583
Right Turn on Red				Yes		Yes
Satd. Flow (RTOR)			39			124
Link Speed (mph)		40	40		35	
Link Distance (ft)		302	1789		381	
Travel Time (s)		5.1	30.5		7.4	
Confl. Peds. (#/hr)	1			1		
Peak Hour Factor	0.94	0.94	0.96	0.96	0.91	0.91
Adj. Flow (vph)	662	752	729	166	176	637
Shared Lane Traffic (%)						
Lane Group Flow (vph)	662	752	895	0	176	637
Enter Blocked Intersection	No	No	No	No	No	No
Lane Alignment	Left	Left	Left	Right	Left	Right
Median Width(ft)		24	24		12	
Link Offset(ft)		0	0		0	
Crosswalk Width(ft)		16	16		16	
Two way Left Turn Lane						
Headway Factor	1.00	1.00	1.00	1.00	1.00	1.00
Turning Speed (mph)	15			9	15	9
Number of Detectors	1	2	2		1	1
Detector Template	Left	Thru	Thru		Left	Right
Leading Detector (ft)	20	100	100		20	20
Trailing Detector (ft)	0	0	0		0	0
Detector 1 Position(ft)	0	0	0		0	0
Detector 1 Size(ft)	20	6	6		20	20
Detector 1 Type	Cl+Ex	Cl+Ex	Cl+Ex		Cl+Ex	Cl+Ex
Detector 1 Channel						
Detector 1 Extend (s)	0.0	0.0	0.0		0.0	0.0
Detector 1 Queue (s)	0.0	0.0	0.0		0.0	0.0
Detector 1 Delay (s)	0.0	0.0	0.0		0.0	0.0
Detector 2 Position(ft)		94	94			
Detector 2 Size(ft)		6	6			
Detector 2 Type		Cl+Ex	Cl+Ex			
Detector 2 Channel						
Detector 2 Extend (s)		0.0	0.0			
Turn Type	Prot	NA	NA		Perm	pm+ov

Lanes, Volumes, Timings  
2: Shiloh Road & Hembree Ln

Existing Project Alter. B Conditions  
Timing Plan: Saturday Midday Peak

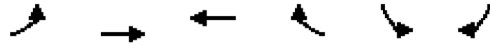

Lane Group	EBL	EBT	WBT	WBR	SBL	SBR
Protected Phases	5	2	6			5
Permitted Phases					4	4 5
Detector Phase	5	2	6		4	5
Switch Phase						
Minimum Initial (s)	3.0	5.0	5.0		5.0	3.0
Minimum Split (s)	7.0	9.0	43.0		9.0	7.0
Total Split (s)	29.0	73.0	44.0		17.0	29.0
Total Split (%)	32.2%	81.1%	48.9%		18.9%	32.2%
Maximum Green (s)	25.0	69.0	40.0		13.0	25.0
Yellow Time (s)	3.0	3.0	3.0		3.0	3.0
All-Red Time (s)	1.0	1.0	1.0		1.0	1.0
Lost Time Adjust (s)	0.0	0.0	0.0		0.0	0.0
Total Lost Time (s)	4.0	4.0	4.0		4.0	4.0
Lead/Lag	Lead		Lag			Lead
Lead-Lag Optimize?	Yes		Yes			Yes
Vehicle Extension (s)	3.0	3.0	3.0		3.0	3.0
Recall Mode	None	None	None		None	None
Walk Time (s)			7.0			
Flash Don't Walk (s)			32.0			
Pedestrian Calls (#/hr)			0			
Act Effct Green (s)	20.1	49.4	25.1		11.5	35.8
Actuated g/C Ratio	0.29	0.71	0.36		0.17	0.52
v/c Ratio	0.66	0.57	0.71		0.60	0.73
Control Delay (s/veh)	26.3	6.6	21.9		39.6	17.1
Queue Delay	0.0	0.1	0.0		0.0	0.0
Total Delay (s/veh)	26.3	6.7	21.9		39.6	17.1
LOS	C	A	C		D	B
Approach Delay (s/veh)		15.9	21.9		22.0	
Approach LOS		B	C		C	

Intersection Summary







Area Type:	Other
Cycle Length:	90
Actuated Cycle Length:	69.2
Natural Cycle:	75
Control Type:	Actuated-Uncoordinated
Maximum v/c Ratio:	0.73
Intersection Signal Delay (s/veh):	19.2
Intersection LOS:	B
Intersection Capacity Utilization:	67.3%
ICU Level of Service:	C
Analysis Period (min):	15

Splits and Phases: 2: Shiloh Road & Hembree Ln



Lanes, Volumes, Timings  
 3: US 101 NB Off-Ramp & Shiloh Road

Existing Project Alter. B Conditions  
 Timing Plan: Saturday Midday Peak

						
Lane Group	EBT	EBR	WBL	WBT	NBL	NBR
Lane Configurations	↑↑			↑	↘	↗↗
Traffic Volume (vph)	536	0	0	942	352	791
Future Volume (vph)	536	0	0	942	352	791
Ideal Flow (vphpl)	1900	1900	1900	1900	1900	1900
Storage Length (ft)		0	0		0	265
Storage Lanes		0	0		1	2
Taper Length (ft)			25		25	
Lane Util. Factor	0.95	1.00	1.00	1.00	1.00	0.88
Ped Bike Factor						
Frt						0.850
Flt Protected					0.950	
Satd. Flow (prot)	3539	0	0	1863	1770	2787
Flt Permitted					0.950	
Satd. Flow (perm)	3539	0	0	1863	1770	2787
Right Turn on Red		Yes				Yes
Satd. Flow (RTOR)						357
Link Speed (mph)	40			40	30	
Link Distance (ft)	186			371	769	
Travel Time (s)	3.2			6.3	17.5	
Confl. Bikes (#/hr)		1				
Peak Hour Factor	0.91	0.91	0.89	0.89	0.95	0.95
Adj. Flow (vph)	589	0	0	1058	371	833
Shared Lane Traffic (%)						
Lane Group Flow (vph)	589	0	0	1058	371	833
Enter Blocked Intersection	No	No	No	No	No	No
Lane Alignment	Left	Right	Left	Left	Left	Right
Median Width(ft)	0			0	12	
Link Offset(ft)	0			0	0	
Crosswalk Width(ft)	16			16	16	
Two way Left Turn Lane						
Headway Factor	1.00	1.00	1.00	1.00	1.00	1.00
Turning Speed (mph)		9	15		15	9
Number of Detectors	2			2	1	1
Detector Template	Thru			Thru	Left	Right
Leading Detector (ft)	100			100	20	20
Trailing Detector (ft)	0			0	0	0
Detector 1 Position(ft)	0			0	0	0
Detector 1 Size(ft)	6			6	20	20
Detector 1 Type	Cl+Ex			Cl+Ex	Cl+Ex	Cl+Ex
Detector 1 Channel						
Detector 1 Extend (s)	0.0			0.0	0.0	0.0
Detector 1 Queue (s)	0.0			0.0	0.0	0.0
Detector 1 Delay (s)	0.0			0.0	0.0	0.0
Detector 2 Position(ft)	94			94		
Detector 2 Size(ft)	6			6		
Detector 2 Type	Cl+Ex			Cl+Ex		
Detector 2 Channel						
Detector 2 Extend (s)	0.0			0.0		
Turn Type	NA			NA	Prot	Perm

Lanes, Volumes, Timings  
 3: US 101 NB Off-Ramp & Shiloh Road

Existing Project Alter. B Conditions  
 Timing Plan: Saturday Midday Peak



Lane Group	EBT	EBR	WBL	WBT	NBL	NBR
Protected Phases	2			6	8	
Permitted Phases						8
Detector Phase	2			6	8	8
Switch Phase						
Minimum Initial (s)	5.0			5.0	5.0	5.0
Minimum Split (s)	9.0			9.0	9.0	9.0
Total Split (s)	37.0			37.0	35.0	35.0
Total Split (%)	51.4%			51.4%	48.6%	48.6%
Maximum Green (s)	33.0			33.0	31.0	31.0
Yellow Time (s)	3.0			3.0	3.0	3.0
All-Red Time (s)	1.0			1.0	1.0	1.0
Lost Time Adjust (s)	0.0			0.0	0.0	0.0
Total Lost Time (s)	4.0			4.0	4.0	4.0
Lead/Lag						
Lead-Lag Optimize?						
Vehicle Extension (s)	3.0			3.0	3.0	3.0
Recall Mode	None			None	None	None
Act Effct Green (s)	33.3			33.3	19.6	19.6
Actuated g/C Ratio	0.55			0.55	0.32	0.32
v/c Ratio	0.30			1.04	0.65	0.73
Control Delay (s/veh)	9.2			58.3	23.2	13.9
Queue Delay	0.0			0.0	0.0	0.0
Total Delay (s/veh)	9.2			58.3	23.2	13.9
LOS	A			E	C	B
Approach Delay (s/veh)	9.2			58.3	16.8	
Approach LOS	A			E	B	

Intersection Summary

Area Type:	Other
Cycle Length:	72
Actuated Cycle Length:	61
Natural Cycle:	65
Control Type:	Actuated-Uncoordinated
Maximum v/c Ratio:	1.04
Intersection Signal Delay (s/veh):	30.6
Intersection LOS:	C
Intersection Capacity Utilization:	130.1%
ICU Level of Service:	H
Analysis Period (min):	15

Splits and Phases: 3: US 101 NB Off-Ramp & Shiloh Road

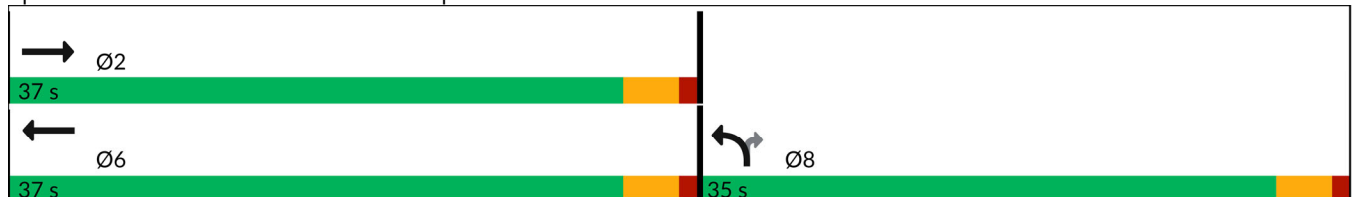

Lanes, Volumes, Timings  
4: Shiloh Road & US 101 SB Off-Ramp

Existing Project Alter. B Conditions  
Timing Plan: Saturday Midday Peak

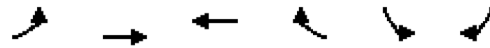

Lane Group	EBL	EBT	WBT	WBR	SBL	SBR
Lane Configurations		↑	↑		↓	↓
Traffic Volume (vph)	0	295	548	0	320	151
Future Volume (vph)	0	295	548	0	320	151
Ideal Flow (vphp)	1900	1900	1900	1900	1900	1900
Storage Length (ft)	0			0	0	275
Storage Lanes	0			0	1	1
Taper Length (ft)	25				25	
Lane Util. Factor	1.00	1.00	1.00	1.00	1.00	1.00
Ped Bike Factor						
Frt						0.850
Flt Protected					0.950	
Satd. Flow (prot)	0	1863	1863	0	1770	1583
Flt Permitted					0.950	
Satd. Flow (perm)	0	1863	1863	0	1770	1583
Right Turn on Red				Yes		Yes
Satd. Flow (RTOR)						222
Link Speed (mph)		40	40		30	
Link Distance (ft)		225	306		486	
Travel Time (s)		3.8	5.2		11.0	
Confl. Bikes (#/hr)				2		
Peak Hour Factor	0.96	0.96	0.96	0.96	0.68	0.68
Adj. Flow (vph)	0	307	571	0	471	222
Shared Lane Traffic (%)						
Lane Group Flow (vph)	0	307	571	0	471	222
Enter Blocked Intersection	No	No	No	No	No	No
Lane Alignment	Left	Left	Left	Right	Left	Right
Median Width(ft)		4	0		12	
Link Offset(ft)		0	0		0	
Crosswalk Width(ft)		16	16		16	
Two way Left Turn Lane						
Headway Factor	1.00	1.00	1.00	1.00	1.00	1.00
Turning Speed (mph)	15			9	15	9
Number of Detectors		2	2		1	1
Detector Template		Thru	Thru		Left	Right
Leading Detector (ft)		100	100		20	20
Trailing Detector (ft)		0	0		0	0
Detector 1 Position(ft)		0	0		0	0
Detector 1 Size(ft)		6	6		20	20
Detector 1 Type		Cl+Ex	Cl+Ex		Cl+Ex	Cl+Ex
Detector 1 Channel						
Detector 1 Extend (s)		0.0	0.0		0.0	0.0
Detector 1 Queue (s)		0.0	0.0		0.0	0.0
Detector 1 Delay (s)		0.0	0.0		0.0	0.0
Detector 2 Position(ft)		94	94			
Detector 2 Size(ft)		6	6			
Detector 2 Type		Cl+Ex	Cl+Ex			
Detector 2 Channel						
Detector 2 Extend (s)		0.0	0.0			
Turn Type		NA	NA		Perm	Perm



Lanes, Volumes, Timings  
4: Shiloh Road & US 101 SB Off-Ramp

Existing Project Alter. B Conditions  
Timing Plan: Saturday Midday Peak

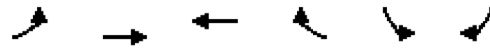

Lane Group	EBL	EBT	WBT	WBR	SBL	SBR
Protected Phases		2	6			
Permitted Phases					4	4
Detector Phase		2	6		4	4
Switch Phase						
Minimum Initial (s)		5.0	5.0		5.0	5.0
Minimum Split (s)		9.0	38.0		9.0	9.0
Total Split (s)		69.0	69.0		21.0	21.0
Total Split (%)		76.7%	76.7%		23.3%	23.3%
Maximum Green (s)		65.0	65.0		17.0	17.0
Yellow Time (s)		3.0	3.0		3.0	3.0
All-Red Time (s)		1.0	1.0		1.0	1.0
Lost Time Adjust (s)		0.0	0.0		0.0	0.0
Total Lost Time (s)		4.0	4.0		4.0	4.0
Lead/Lag						
Lead-Lag Optimize?						
Vehicle Extension (s)		3.0	3.0		3.0	3.0
Recall Mode		None	None		None	None
Walk Time (s)			7.0			
Flash Don't Walk (s)			27.0			
Pedestrian Calls (#/hr)			0			
Act Effct Green (s)		18.5	18.5		17.2	17.2
Actuated g/C Ratio		0.42	0.42		0.39	0.39
v/c Ratio		0.39	0.73		0.68	0.29
Control Delay (s/veh)		9.9	16.3		20.2	3.5
Queue Delay		0.0	0.0		0.0	0.0
Total Delay (s/veh)		9.9	16.3		20.2	3.5
LOS		A	B		C	A
Approach Delay (s/veh)		9.9	16.3		14.9	
Approach LOS		A	B		B	

Intersection Summary

Area Type:	Other
Cycle Length:	90
Actuated Cycle Length:	43.8
Natural Cycle:	60
Control Type:	Actuated-Uncoordinated
Maximum v/c Ratio:	0.73
Intersection Signal Delay (s/veh):	14.4
Intersection LOS:	B
Intersection Capacity Utilization:	117.3%
ICU Level of Service:	H
Analysis Period (min):	15

Splits and Phases: 4: Shiloh Road & US 101 SB Off-Ramp

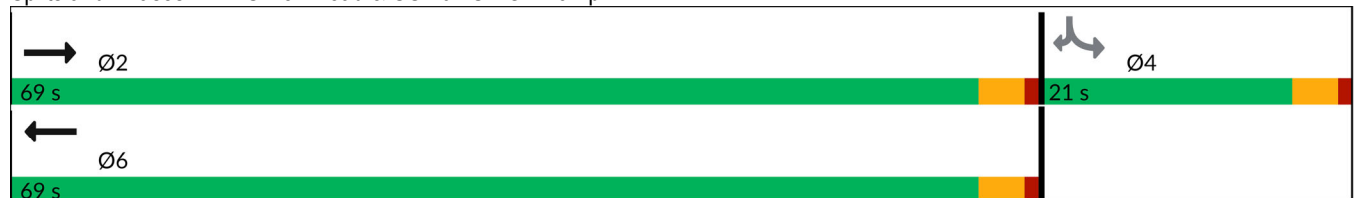

Lanes, Volumes, Timings  
5: Caletti Ave & Shiloh Road

Existing Project Alter. B Conditions  
Timing Plan: Saturday Midday Peak



















	→	↘	↙	←	↖	↗
Lane Group	EBT	EBR	WBL	WBT	NBL	NBR
Lane Configurations	↑↑		↘	↑	↘	↗
Traffic Volume (vph)	567	20	81	627	16	78
Future Volume (vph)	567	20	81	627	16	78
Ideal Flow (vphp)	1900	1900	1900	1900	1900	1900
Storage Length (ft)		0	68		0	0
Storage Lanes		0	1		1	1
Taper Length (ft)			50		25	
Lane Util. Factor	0.95	0.95	1.00	1.00	1.00	1.00
Ped Bike Factor						
Frt	0.995					0.850
Flt Protected			0.950		0.950	
Satd. Flow (prot)	3522	0	1770	1863	1770	1583
Flt Permitted			0.950		0.950	
Satd. Flow (perm)	3522	0	1770	1863	1770	1583
Link Speed (mph)	40			40	30	
Link Distance (ft)	1081			184	459	
Travel Time (s)	18.4			3.1	10.4	
Confl. Peds. (#/hr)					1	
Confl. Bikes (#/hr)		1				
Peak Hour Factor	0.92	0.92	0.87	0.87	0.78	0.78
Adj. Flow (vph)	616	22	93	721	21	100
Shared Lane Traffic (%)						
Lane Group Flow (vph)	638	0	93	721	21	100
Enter Blocked Intersection	No	No	No	No	No	No
Lane Alignment	Left	Right	Left	Left	Left	Right
Median Width(ft)	12			12	12	
Link Offset(ft)	0			0	0	
Crosswalk Width(ft)	16			16	16	
Two way Left Turn Lane						
Headway Factor	1.00	1.00	1.00	1.00	1.00	1.00
Turning Speed (mph)		9	15		15	9
Sign Control	Free			Free	Stop	

Intersection Summary

Area Type:	Other
Control Type:	Unsignalized
Intersection Capacity Utilization	43.0%
Analysis Period (min)	15
	ICU Level of Service A

Lanes, Volumes, Timings  
6: Conde Lane & Shiloh Road

Existing Project Alter. B Conditions  
Timing Plan: Saturday Midday Peak

												
Lane Group	EBL	EBT	EBR	WBL	WBT	WBR	NBL	NBT	NBR	SBL	SBT	SBR
Lane Configurations												
Traffic Volume (vph)	29	383	1	9	426	204	1	0	6	197	0	28
Future Volume (vph)	29	383	1	9	426	204	1	0	6	197	0	28
Ideal Flow (vphpl)	1900	1900	1900	1900	1900	1900	1900	1900	1900	1900	1900	1900
Storage Length (ft)	90		0	127		0	0		0	0		40
Storage Lanes	1		0	1		0	0		0	0		1
Taper Length (ft)	70			40			25			25		
Lane Util. Factor	1.00	0.95	0.95	1.00	0.95	0.95	1.00	1.00	1.00	1.00	1.00	1.00
Ped Bike Factor					0.99							
Frt					0.951			0.887				0.850
Flt Protected	0.950			0.950				0.992			0.950	
Satd. Flow (prot)	1770	3539	0	1770	3342	0	0	1639	0	0	1770	1583
Flt Permitted	0.950			0.950				0.992			0.950	
Satd. Flow (perm)	1770	3539	0	1770	3342	0	0	1639	0	0	1770	1583
Right Turn on Red			Yes			Yes			Yes			No
Satd. Flow (RTOR)					83			89				
Link Speed (mph)		40			40			30				35
Link Distance (ft)		815			1081			418				522
Travel Time (s)		13.9			18.4			9.5				10.2
Confl. Bikes (#/hr)						2						
Peak Hour Factor	0.96	0.96	0.96	0.91	0.91	0.91	0.58	0.58	0.58	0.78	0.78	0.78
Adj. Flow (vph)	30	399	1	10	468	224	2	0	10	253	0	36
Shared Lane Traffic (%)												
Lane Group Flow (vph)	30	400	0	10	692	0	0	12	0	0	253	36
Enter Blocked Intersection	No	No	No	No	No	No	No	No	No	No	No	No
Lane Alignment	Left	Left	Right	Left	Left	Right	Left	Left	Right	Left	Left	Right
Median Width(ft)		12			12			0				0
Link Offset(ft)		0			0			0				0
Crosswalk Width(ft)		16			16			16				16
Two way Left Turn Lane												
Headway Factor	1.00	1.00	1.00	1.00	1.00	1.00	1.00	1.00	1.00	1.00	1.00	1.00
Turning Speed (mph)	15		9	15		9	15		9	15		9
Number of Detectors	1	2		1	2		1	2		1	1	1
Detector Template	Left	Thru		Left	Thru		Left	Thru		Left	Thru	Right
Leading Detector (ft)	20	100		20	100		20	100		20	30	20
Trailing Detector (ft)	0	0		0	0		0	0		0	0	0
Detector 1 Position(ft)	0	0		0	0		0	0		0	0	0
Detector 1 Size(ft)	20	6		20	6		20	6		20	30	20
Detector 1 Type	Cl+Ex	Cl+Ex		Cl+Ex	Cl+Ex		Cl+Ex	Cl+Ex		Cl+Ex	Cl+Ex	Cl+Ex
Detector 1 Channel												
Detector 1 Extend (s)	0.0	0.0		0.0	0.0		0.0	0.0		0.0	0.0	0.0
Detector 1 Queue (s)	0.0	0.0		0.0	0.0		0.0	0.0		0.0	0.0	0.0
Detector 1 Delay (s)	0.0	0.0		0.0	0.0		0.0	0.0		0.0	0.0	0.0
Detector 2 Position(ft)		94			94			94				
Detector 2 Size(ft)		6			6			6				
Detector 2 Type		Cl+Ex			Cl+Ex			Cl+Ex				
Detector 2 Channel												
Detector 2 Extend (s)		0.0			0.0			0.0				
Turn Type	Prot	NA		Prot	NA		Split	NA		Split	NA	custom

Lanes, Volumes, Timings  
6: Conde Lane & Shiloh Road

Existing Project Alter. B Conditions  
Timing Plan: Saturday Midday Peak

Lane Group	EBL	EBT	EBR	WBL	WBT	WBR	NBL	NBT	NBR	SBL	SBT	SBR
Protected Phases	5	2		1	6		7	7		4	4	
Permitted Phases												6
Detector Phase	5	2		1	6		7	7		4	4	6
Switch Phase												
Minimum Initial (s)	8.0	8.0		8.0	8.0		10.0	10.0		11.0	11.0	8.0
Minimum Split (s)	12.0	46.0		12.0	12.0		37.0	37.0		15.0	15.0	12.0
Total Split (s)	13.0	46.0		12.0	45.0		37.0	37.0		15.0	15.0	45.0
Total Split (%)	11.8%	41.8%		10.9%	40.9%		33.6%	33.6%		13.6%	13.6%	40.9%
Maximum Green (s)	9.0	42.0		8.0	41.0		33.0	33.0		11.0	11.0	41.0
Yellow Time (s)	3.0	3.0		3.0	3.0		3.0	3.0		3.0	3.0	3.0
All-Red Time (s)	1.0	1.0		1.0	1.0		1.0	1.0		1.0	1.0	1.0
Lost Time Adjust (s)	0.0	0.0		0.0	0.0		0.0	0.0		0.0	0.0	0.0
Total Lost Time (s)	4.0	4.0		4.0	4.0		4.0	4.0		4.0	4.0	4.0
Lead/Lag	Lead	Lag		Lead	Lag							Lag
Lead-Lag Optimize?	Yes	Yes		Yes	Yes							Yes
Vehicle Extension (s)	3.0	3.0		3.0	3.0		3.0	3.0		3.0	3.0	3.0
Recall Mode	None	None		None	None		None	None		None	None	None
Walk Time (s)		7.0					7.0	7.0				
Flash Don't Walk (s)		35.0					26.0	26.0				
Pedestrian Calls (#/hr)		0					0	0				
Act Effct Green (s)	9.0	15.2		8.9	15.1		11.1			12.3	15.1	
Actuated g/C Ratio	0.23	0.39		0.23	0.38		0.28			0.31	0.38	
v/c Ratio	0.07	0.29		0.02	0.52		0.02			0.46	0.06	
Control Delay (s/veh)	19.3	10.1		19.7	10.7		0.1			21.3	10.3	
Queue Delay	0.0	0.0		0.0	0.0		0.0			0.0	0.0	
Total Delay (s/veh)	19.3	10.1		19.7	10.7		0.1			21.3	10.3	
LOS	B	B		B	B		A			C	B	
Approach Delay (s/veh)		10.7			10.8		0.1			19.9		
Approach LOS		B			B		A			B		

Intersection Summary

Area Type:	Other
Cycle Length:	110
Actuated Cycle Length:	39.3
Natural Cycle:	110
Control Type:	Actuated-Uncoordinated
Maximum v/c Ratio:	0.52
Intersection Signal Delay (s/veh):	12.5
Intersection LOS:	B
Intersection Capacity Utilization:	48.3%
ICU Level of Service:	A
Analysis Period (min):	15

Splits and Phases: 6: Conde Lane & Shiloh Road



Lanes, Volumes, Timings  
7: Driveway 1/Gridley Drive & Shiloh Road





















Existing Project Alter. B Conditions  
Timing Plan: Saturday Midday Peak

Lane Group	EBL	EBT	EBR	WBL	WBT	WBR	NBL	NBT	NBR	SBL	SBT	SBR
Lane Configurations												
Traffic Volume (vph)	20	422	103	0	438	0	113	0	0	0	0	18
Future Volume (vph)	20	422	103	0	438	0	113	0	0	0	0	18
Ideal Flow (vphp)	1900	1900	1900	1900	1900	1900	1900	1900	1900	1900	1900	1900
Storage Length (ft)	0		150	0		0	0		0	0		0
Storage Lanes	0		1	0		0	1		0	0		0
Taper Length (ft)	25			25			25			25		
Lane Util. Factor	1.00	1.00	1.00	1.00	1.00	1.00	1.00	1.00	1.00	1.00	1.00	1.00
Ped Bike Factor												
Frt			0.850								0.865	
Flt Protected		0.998					0.950					
Satd. Flow (prot)	0	1859	1583	0	1863	0	1770	1863	0	0	1611	0
Flt Permitted		0.998					0.950					
Satd. Flow (perm)	0	1859	1583	0	1863	0	1770	1863	0	0	1611	0
Link Speed (mph)		40			40			30			30	
Link Distance (ft)		608			2146			248			715	
Travel Time (s)		10.4			36.6			5.6			16.3	
Confl. Peds. (#/hr)	1											
Confl. Bikes (#/hr)			1			3						
Peak Hour Factor	0.93	0.93	0.93	0.88	0.88	0.88	1.00	1.00	1.00	0.56	0.56	0.56
Adj. Flow (vph)	22	454	111	0	498	0	113	0	0	0	0	32
Shared Lane Traffic (%)												
Lane Group Flow (vph)	0	476	111	0	498	0	113	0	0	0	32	0
Enter Blocked Intersection	No	No	No	No	No	No	No	No	No	No	No	No
Lane Alignment	Left	Left	Right	Left	Left	Right	Left	Left	Right	Left	Left	Right
Median Width(ft)		0			0			12			12	
Link Offset(ft)		0			0			0			0	
Crosswalk Width(ft)		16			16			16			16	
Two way Left Turn Lane												
Headway Factor	1.00	1.00	1.00	1.00	1.00	1.00	1.00	1.00	1.00	1.00	1.00	1.00
Turning Speed (mph)	15		9	15		9	15		9	15		9
Sign Control		Free			Free			Stop			Stop	

Intersection Summary												
Area Type:	Other											
Control Type:	Unsignalized											
Intersection Capacity Utilization	58.1%					ICU Level of Service B						
Analysis Period (min)	15											

Lanes, Volumes, Timings  
8: Old Redwood Hwy & Driveway 2











Existing Project Alter. B Conditions  
Timing Plan: Saturday Midday Peak

												
Lane Group	EBL	EBT	EBR	WBL	WBT	WBR	NBL	NBT	NBR	SBL	SBT	SBR
Lane Configurations												
Traffic Volume (vph)	1	0	2	67	0	106	1	403	61	97	342	4
Future Volume (vph)	1	0	2	67	0	106	1	403	61	97	342	4
Ideal Flow (vphp)	1900	1900	1900	1900	1900	1900	1900	1900	1900	1900	1900	1900
Storage Length (ft)	0		0	0		0	0		100	50		0
Storage Lanes	0		0	1		0	0		1	1		0
Taper Length (ft)	25			25			25			25		
Lane Util. Factor	1.00	1.00	1.00	1.00	1.00	1.00	1.00	1.00	1.00	1.00	1.00	1.00
Ped Bike Factor												
Frt		0.916			0.850				0.850		0.998	
Flt Protected		0.982		0.950						0.950		
Satd. Flow (prot)	0	1676	0	1770	1583	0	0	1863	1583	1770	1859	0
Flt Permitted		0.982		0.950						0.950		
Satd. Flow (perm)	0	1676	0	1770	1583	0	0	1863	1583	1770	1859	0
Link Speed (mph)		30			30			45			45	
Link Distance (ft)		98			385			520			748	
Travel Time (s)		2.2			8.8			7.9			11.3	
Confl. Peds. (#/hr)							1		4	4		1
Confl. Bikes (#/hr)									3			9
Peak Hour Factor	0.38	0.38	0.38	1.00	1.00	1.00	0.94	0.94	0.94	0.93	0.93	0.93
Adj. Flow (vph)	3	0	5	67	0	106	1	429	65	104	368	4
Shared Lane Traffic (%)												
Lane Group Flow (vph)	0	8	0	67	106	0	0	430	65	104	372	0
Enter Blocked Intersection	No	No	No	No	No	No	No	No	No	No	No	No
Lane Alignment	Left	Left	Right	Left	Left	Right	Left	Left	Right	Left	Left	Right
Median Width(ft)		12			12			12			12	
Link Offset(ft)		0			0			0			0	
Crosswalk Width(ft)		16			16			16			16	
Two way Left Turn Lane												
Headway Factor	1.00	1.00	1.00	1.00	1.00	1.00	1.00	1.00	1.00	1.00	1.00	1.00
Turning Speed (mph)	15		9	15		9	15		9	15		9
Sign Control		Stop			Stop			Free			Free	

Intersection Summary	
Area Type:	Other
Control Type:	Unsignalized
Intersection Capacity Utilization	58.8%
Analysis Period (min)	15
	ICU Level of Service B

Lanes, Volumes, Timings  
9: Driveway 3 & Shiloh Road

Existing Project Alter. B Conditions  
Timing Plan: Saturday Midday Peak

						
Lane Group	EBT	EBR	WBL	WBT	NBL	NBR
Lane Configurations						
Traffic Volume (vph)	92	316	30	86	346	33
Future Volume (vph)	92	316	30	86	346	33
Ideal Flow (vphp)	1900	1900	1900	1900	1900	1900
Storage Length (ft)		200	0		0	0
Storage Lanes		1	0		1	1
Taper Length (ft)			25		25	
Lane Util. Factor	1.00	1.00	1.00	1.00	1.00	1.00
Ped Bike Factor						
Frt		0.850				0.850
Flt Protected				0.987	0.950	
Satd. Flow (prot)	1863	1583	0	1839	1770	1583
Flt Permitted				0.987	0.950	
Satd. Flow (perm)	1863	1583	0	1839	1770	1583
Link Speed (mph)	40			40	30	
Link Distance (ft)	2146			134	402	
Travel Time (s)	36.6			2.3	9.1	
Confl. Peds. (#/hr)		1				
Peak Hour Factor	0.88	0.88	0.80	0.80	1.00	1.00
Adj. Flow (vph)	105	359	38	108	346	33
Shared Lane Traffic (%)						
Lane Group Flow (vph)	105	359	0	146	346	33
Enter Blocked Intersection	No	No	No	No	No	No
Lane Alignment	Left	Right	Left	Left	Left	Right
Median Width(ft)	0			0	12	
Link Offset(ft)	0			0	0	
Crosswalk Width(ft)	16			16	16	
Two way Left Turn Lane						
Headway Factor	1.00	1.00	1.00	1.00	1.00	1.00
Turning Speed (mph)		9	15		15	9
Sign Control	Free			Free	Stop	
<b>Intersection Summary</b>						
Area Type:	Other					
Control Type:	Unsignalized					
Intersection Capacity Utilization	38.7%			ICU Level of Service A		
Analysis Period (min)	15					

Lanes, Volumes, Timings

Existing Project Alter. B Conditions

10: US 101 NB Off Ramp/Lakewood Drive & Old Redwood Highway Timing Plan: Saturday Midday Peak



Lane Group	EBL	EBT	EBR	WBL	WBT	WBR	NBL	NBT	NBR	SBL	SBT	SBR
Lane Configurations	↔↔	↑			↔↔		↔	↔↔		↔↔		↔
Traffic Volume (vph)	252	336	0	0	508	242	281	266	125	214	0	615
Future Volume (vph)	252	336	0	0	508	242	281	266	125	214	0	615
Ideal Flow (vphpl)	1900	1900	1900	1900	1900	1900	1900	1900	1900	1900	1900	1900
Storage Length (ft)	155		0	0		0	270		150	120		0
Storage Lanes	1		0	0		0	1		1	1		1
Taper Length (ft)	50			25			165			75		
Lane Util. Factor	0.97	1.00	1.00	1.00	0.95	0.95	0.91	0.91	0.95	0.97	1.00	1.00
Ped Bike Factor	1.00				0.99			1.00		1.00		
Fr <sub>t</sub>					0.952			0.958				0.850
Fl <sub>t</sub> Protected	0.950						0.950	0.994		0.950		
Satd. Flow (prot)	3433	1863	0	0	3352	0	1610	3217	0	3433	0	1583
Fl <sub>t</sub> Permitted	0.950						0.950	0.994		0.950		
Satd. Flow (perm)	3429	1863	0	0	3352	0	1610	3217	0	3430	0	1583
Right Turn on Red			Yes			Yes			Yes			Yes
Satd. Flow (RTOR)					92			61				294
Link Speed (mph)		35			35			30				30
Link Distance (ft)		226			617			716				478
Travel Time (s)		4.4			12.0			16.3				10.9
Confl. Peds. (#/hr)	2		1	1		2			1	1		
Confl. Bikes (#/hr)			10			3						
Peak Hour Factor	0.95	0.95	0.95	0.89	0.89	0.89	0.98	0.98	0.98	0.88	0.88	0.88
Adj. Flow (vph)	265	354	0	0	571	272	287	271	128	243	0	699
Shared Lane Traffic (%)							20%					
Lane Group Flow (vph)	265	354	0	0	843	0	230	456	0	243	0	699
Enter Blocked Intersection	No	No	No	No	No	No	No	No	No	No	No	No
Lane Alignment	Left	Left	Right	Left	Left	Right	Left	Left	Right	Left	Left	Right
Median Width(ft)		24			24			24				24
Link Offset(ft)		0			0			0				0
Crosswalk Width(ft)		16			16			16				16
Two way Left Turn Lane												
Headway Factor	1.00	1.00	1.00	1.00	1.00	1.00	1.00	1.00	1.00	1.00	1.00	1.00
Turning Speed (mph)	15		9	15		9	15		9	15		9
Number of Detectors	1	2			2		1	2		1		1
Detector Template	Left	Thru			Thru		Left	Thru		Left		Right
Leading Detector (ft)	20	100			100		20	100		20		20
Trailing Detector (ft)	0	0			0		0	0		0		0
Detector 1 Position(ft)	0	0			0		0	0		0		0
Detector 1 Size(ft)	20	6			6		20	6		20		20
Detector 1 Type	Cl+Ex	Cl+Ex			Cl+Ex		Cl+Ex	Cl+Ex		Cl+Ex		Cl+Ex
Detector 1 Channel												
Detector 1 Extend (s)	0.0	0.0			0.0		0.0	0.0		0.0		0.0
Detector 1 Queue (s)	0.0	0.0			0.0		0.0	0.0		0.0		0.0
Detector 1 Delay (s)	0.0	0.0			0.0		0.0	0.0		0.0		0.0
Detector 2 Position(ft)		94			94			94				
Detector 2 Size(ft)		6			6			6				
Detector 2 Type		Cl+Ex			Cl+Ex			Cl+Ex				
Detector 2 Channel												
Detector 2 Extend (s)		0.0			0.0			0.0				



Lanes, Volumes, Timings

Existing Project Alter. B Conditions

10: US 101 NB Off Ramp/Lakewood Drive & Old Redwood Highway Timing Plan: Saturday Midday Peak



Lane Group	EBL	EBT	EBR	WBL	WBT	WBR	NBL	NBT	NBR	SBL	SBT	SBR
Turn Type	Prot	NA			NA		Split	NA		Prot		pm+ov
Protected Phases	5	2			6		8	8		7		5
Permitted Phases												5 8
Detector Phase	5	2			6		8	8		7		5
Switch Phase												
Minimum Initial (s)	7.0	10.0			10.0		10.0	10.0		7.0		7.0
Minimum Split (s)	11.0	32.1			32.1		33.7	33.7		11.0		11.0
Total Split (s)	12.0	45.3			33.3		33.7	33.7		11.0		12.0
Total Split (%)	13.3%	50.3%			37.0%		37.4%	37.4%		12.2%		13.3%
Maximum Green (s)	8.0	40.2			28.2		29.0	29.0		7.0		8.0
Yellow Time (s)	3.0	4.1			4.1		3.7	3.7		3.0		3.0
All-Red Time (s)	1.0	1.0			1.0		1.0	1.0		1.0		1.0
Lost Time Adjust (s)	0.0	0.0			0.0		0.0	0.0		0.0		0.0
Total Lost Time (s)	4.0	5.1			5.1		4.7	4.7		4.0		4.0
Lead/Lag	Lead				Lag		Lag	Lag		Lead		Lead
Lead-Lag Optimize?	Yes				Yes		Yes	Yes		Yes		Yes
Vehicle Extension (s)	3.0	3.0			3.0		3.0	3.0		3.0		3.0
Recall Mode	None	Max			Max		None	None		None		None
Walk Time (s)		7.0			7.0		7.0	7.0				
Flash Don't Walk (s)		20.0			17.0		22.0	22.0				
Pedestrian Calls (#/hr)		0			0		0	0				
Act Effct Green (s)	8.0	40.4			28.4		18.0	18.0		7.0		30.8
Actuated g/C Ratio	0.10	0.51			0.36		0.23	0.23		0.09		0.39
v/c Ratio	0.76	0.37			0.67		0.63	0.59		0.80		0.88
Control Delay (s/veh)	52.0	14.5			23.2		35.3	26.2		57.8		26.6
Queue Delay	0.0	0.0			0.0		0.0	0.0		0.0		0.0
Total Delay (s/veh)	52.0	14.5			23.2		35.3	26.2		57.8		26.6
LOS	D	B			C		D	C		E		C
Approach Delay (s/veh)		30.5			23.2			29.3				34.7
Approach LOS		C			C			C				C

Intersection Summary

Area Type: Other  
 Cycle Length: 90  
 Actuated Cycle Length: 79.4  
 Natural Cycle: 90  
 Control Type: Actuated-Uncoordinated  
 Maximum v/c Ratio: 0.88  
 Intersection Signal Delay (s/veh): 29.5  
 Intersection LOS: C  
 Intersection Capacity Utilization 84.8%  
 ICU Level of Service E  
 Analysis Period (min) 15

Splits and Phases: 10: US 101 NB Off Ramp/Lakewood Drive & Old Redwood Highway

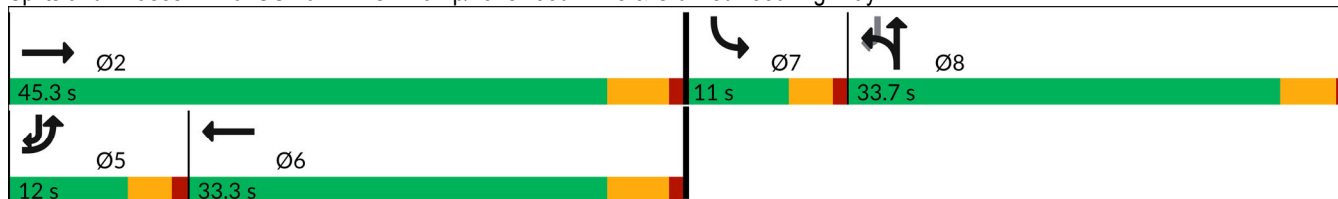

Lanes, Volumes, Timings  
 11: Old Redwood Highway & US 101 NB On Ramp

Existing Project Alter. B Conditions  
 Timing Plan: Saturday Midday Peak



Lane Group	EBL	EBT	WBT	WBR	SBL	SBR
Lane Configurations						
Traffic Volume (vph)	76	592	1150	189	0	0
Future Volume (vph)	76	592	1150	189	0	0
Ideal Flow (vphpl)	1900	1900	1900	1900	1900	1900
Storage Length (ft)	245			0	0	0
Storage Lanes	1			0	0	0
Taper Length (ft)	50				25	
Lane Util. Factor	1.00	0.95	0.95	0.95	1.00	1.00
Ped Bike Factor						
Frt			0.979			
Flt Protected	0.950					
Satd. Flow (prot)	1770	3539	3465	0	0	0
Flt Permitted	0.950					
Satd. Flow (perm)	1770	3539	3465	0	0	0
Link Speed (mph)		35	35		30	
Link Distance (ft)		531	226		299	
Travel Time (s)		10.3	4.4		6.8	
Confl. Peds. (#/hr)	8			8		
Confl. Bikes (#/hr)				4		
Peak Hour Factor	0.96	0.96	0.92	0.92	0.25	0.25
Adj. Flow (vph)	79	617	1250	205	0	0
Shared Lane Traffic (%)						
Lane Group Flow (vph)	79	617	1455	0	0	0
Enter Blocked Intersection	No	No	No	No	No	No
Lane Alignment	Left	Left	Left	Right	Left	Right
Median Width(ft)		12	12		0	
Link Offset(ft)		0	0		0	
Crosswalk Width(ft)		16	16		16	
Two way Left Turn Lane						
Headway Factor	1.00	1.00	1.00	1.00	1.00	1.00
Turning Speed (mph)	15			9	15	9
Sign Control		Free	Free		Free	

Intersection Summary	
Area Type:	Other
Control Type:	Unsignalized
Intersection Capacity Utilization	66.6% ICU Level of Service C
Analysis Period (min)	15

Lanes, Volumes, Timings

Existing Project Alter. B Conditions

12: US 101 SB On Ramp/US 101 SB Off Ramp & Old Redwood Highway Timing Plan: Saturday Midday Peak



Lane Group	EBL	EBT	EBR	WBL	WBT	WBR	NBL	NBT	NBR	SBL	SBT	SBR
Lane Configurations		↑↑	↗	↖	↑↑					↘	↕	
Traffic Volume (vph)	0	483	368	428	718	0	0	0	0	194	1	76
Future Volume (vph)	0	483	368	428	718	0	0	0	0	194	1	76
Ideal Flow (vphpl)	1900	1900	1900	1900	1900	1900	1900	1900	1900	1900	1900	1900
Storage Length (ft)	0		0	250		0	0		0	420		0
Storage Lanes	0		1	0		0	0		0	1		0
Taper Length (ft)	25			165			25			75		
Lane Util. Factor	1.00	0.95	1.00	1.00	0.95	1.00	1.00	1.00	1.00	0.95	0.95	1.00
Ped Bike Factor			0.98	1.00								
Frt			0.850								0.913	
Flt Protected				0.950						0.950	0.980	
Satd. Flow (prot)	0	3539	1583	1770	3539	0	0	0	0	1681	1583	0
Flt Permitted				0.950						0.950	0.980	
Satd. Flow (perm)	0	3539	1553	1768	3539	0	0	0	0	1681	1583	0
Right Turn on Red			Yes			Yes			Yes			Yes
Satd. Flow (RTOR)			379								84	
Link Speed (mph)		35			35			30			30	
Link Distance (ft)		423			531			621			831	
Travel Time (s)		8.2			10.3			14.1			18.9	
Confl. Peds. (#/hr)	11		2	2		11						
Confl. Bikes (#/hr)			10			2						
Peak Hour Factor	0.97	0.97	0.97	0.96	0.96	0.96	0.25	0.25	0.25	0.72	0.72	0.72
Adj. Flow (vph)	0	498	379	446	748	0	0	0	0	269	1	106
Shared Lane Traffic (%)										28%		
Lane Group Flow (vph)	0	498	379	446	748	0	0	0	0	194	182	0
Enter Blocked Intersection	No	No	No	No	No	No	No	No	No	No	No	No
Lane Alignment	Left	Left	Right	Left	Left	Right	Left	Left	Right	Left	Left	Right
Median Width(ft)		24			24			12			12	
Link Offset(ft)		0			0			0			0	
Crosswalk Width(ft)		16			16			16			16	
Two way Left Turn Lane												
Headway Factor	1.00	1.00	1.00	1.00	1.00	1.00	1.00	1.00	1.00	1.00	1.00	1.00
Turning Speed (mph)	15		9	15		9	15		9	15		9
Number of Detectors		2	1	1	2					1	2	
Detector Template		Thru	Right	Left	Thru					Left	Thru	
Leading Detector (ft)		100	20	20	100					20	100	
Trailing Detector (ft)		0	0	0	0					0	0	
Detector 1 Position(ft)		0	0	0	0					0	0	
Detector 1 Size(ft)		6	20	20	6					20	6	
Detector 1 Type		Cl+Ex	Cl+Ex	Cl+Ex	Cl+Ex					Cl+Ex	Cl+Ex	
Detector 1 Channel												
Detector 1 Extend (s)		0.0	0.0	0.0	0.0					0.0	0.0	
Detector 1 Queue (s)		0.0	0.0	0.0	0.0					0.0	0.0	
Detector 1 Delay (s)		0.0	0.0	0.0	0.0					0.0	0.0	
Detector 2 Position(ft)		94			94							94
Detector 2 Size(ft)		6			6							6
Detector 2 Type		Cl+Ex			Cl+Ex							Cl+Ex
Detector 2 Channel												
Detector 2 Extend (s)		0.0			0.0							0.0

Lanes, Volumes, Timings

Existing Project Alter. B Conditions

12: US 101 SB On Ramp/US 101 SB Off Ramp & Old Redwood Highway Timing Plan: Saturday Midday Peak



Lane Group	EBL	EBT	EBR	WBL	WBT	WBR	NBL	NBT	NBR	SBL	SBT	SBR
Turn Type		NA	Perm	Prot	NA					Perm	NA	
Protected Phases		6		5	2						8	
Permitted Phases			6							8		
Detector Phase		6	6	5	2					8	8	
Switch Phase												
Minimum Initial (s)		10.0	10.0	7.0	10.0					10.0	10.0	
Minimum Split (s)		32.1	32.1	11.0	38.1					14.7	14.7	
Total Split (s)		32.3	32.3	23.0	55.3					14.7	14.7	
Total Split (%)		46.1%	46.1%	32.9%	79.0%					21.0%	21.0%	
Maximum Green (s)		27.2	27.2	19.0	50.2					10.0	10.0	
Yellow Time (s)		4.1	4.1	3.0	4.1					3.7	3.7	
All-Red Time (s)		1.0	1.0	1.0	1.0					1.0	1.0	
Lost Time Adjust (s)		0.0	0.0	0.0	0.0					0.0	0.0	
Total Lost Time (s)		5.1	5.1	4.0	5.1					4.7	4.7	
Lead/Lag		Lag	Lag	Lead								
Lead-Lag Optimize?		Yes	Yes	Yes								
Vehicle Extension (s)		3.0	3.0	3.0	3.0					3.0	3.0	
Recall Mode		Max	Max	None	Max					None	None	
Walk Time (s)		7.0	7.0		7.0							
Flash Don't Walk (s)		20.0	20.0		25.0							
Pedestrian Calls (#/hr)		0	0		0							
Act Effct Green (s)		27.3	27.3	18.9	50.2					10.0	10.0	
Actuated g/C Ratio		0.39	0.39	0.27	0.72					0.14	0.14	
v/c Ratio		0.36	0.45	0.94	0.29					0.81	0.61	
Control Delay (s/veh)		16.1	3.8	55.6	3.9					56.6	25.6	
Queue Delay		0.0	0.0	0.0	0.0					0.0	0.0	
Total Delay (s/veh)		16.1	3.8	55.6	3.9					56.6	25.6	
LOS		B	A	E	A					E	C	
Approach Delay (s/veh)		10.8			23.2						41.6	
Approach LOS		B			C						D	

Intersection Summary

Area Type: Other  
 Cycle Length: 70  
 Actuated Cycle Length: 70  
 Natural Cycle: 70  
 Control Type: Actuated-Uncoordinated  
 Maximum v/c Ratio: 0.94  
 Intersection Signal Delay (s/veh): 21.6  
 Intersection LOS: C  
 Intersection Capacity Utilization 66.6%  
 ICU Level of Service C  
 Analysis Period (min) 15



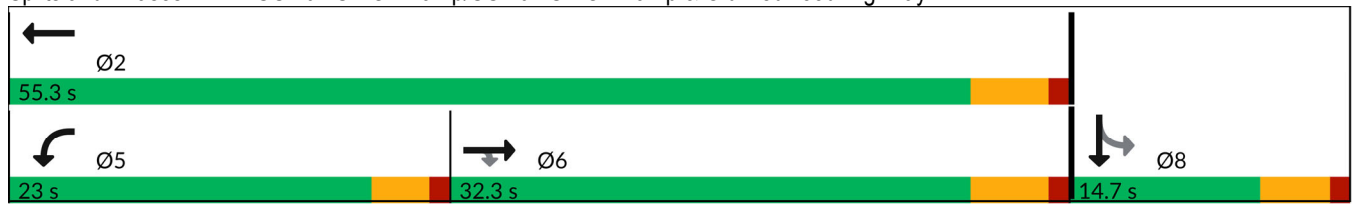



















Splits and Phases: 12: US 101 SB On Ramp/US 101 SB Off Ramp & Old Redwood Highway



Appendix E – Existing plus Alternative C Project Conditions  
Intersection Level of Service Worksheets

HCM 6th Signalized Intersection Summary  
 1: Old Redwood Hwy & Shiloh Road

Existing Project Alter. C Conditions  
 Timing Plan: A.M. PEAK

												
Movement	EBL	EBT	EBR	WBL	WBT	WBR	NBL	NBT	NBR	SBL	SBT	SBR
Lane Configurations												
Traffic Volume (veh/h)	108	160	78	22	89	16	74	122	34	20	230	169
Future Volume (veh/h)	108	160	78	22	89	16	74	122	34	20	230	169
Initial Q (Qb), veh	0	0	0	0	0	0	0	0	0	0	0	0
Ped-Bike Adj(A_pbT)	1.00		1.00	1.00		1.00	1.00		1.00	1.00		0.98
Parking Bus, Adj	1.00	1.00	1.00	1.00	1.00	1.00	1.00	1.00	1.00	1.00	1.00	1.00
Work Zone On Approach		No			No			No			No	
Adj Sat Flow, veh/h/ln	1870	1870	1870	1870	1870	1870	1870	1870	1870	1870	1870	1870
Adj Flow Rate, veh/h	133	198	96	25	100	18	80	131	37	24	271	199
Peak Hour Factor	0.81	0.81	0.81	0.89	0.89	0.89	0.93	0.93	0.93	0.85	0.85	0.85
Percent Heavy Veh, %	2	2	2	2	2	2	2	2	2	2	2	2
Cap, veh/h	320	336	284	38	154	165	193	414	351	200	422	350
Arrive On Green	0.18	0.18	0.18	0.10	0.10	0.10	0.11	0.22	0.22	0.11	0.23	0.23
Sat Flow, veh/h	1781	1870	1585	370	1481	1585	1781	1870	1585	1781	1870	1551
Grp Volume(v), veh/h	133	198	96	125	0	18	80	131	37	24	271	199
Grp Sat Flow(s),veh/h/ln	1781	1870	1585	1852	0	1585	1781	1870	1585	1781	1870	1551
Q Serve(g_s), s	2.9	4.3	2.4	2.9	0.0	0.5	1.9	2.6	0.8	0.5	5.8	5.1
Cycle Q Clear(g_c), s	2.9	4.3	2.4	2.9	0.0	0.5	1.9	2.6	0.8	0.5	5.8	5.1
Prop In Lane	1.00		1.00	0.20		1.00	1.00		1.00	1.00		1.00
Lane Grp Cap(c), veh/h	320	336	284	192	0	165	193	414	351	200	422	350
V/C Ratio(X)	0.42	0.59	0.34	0.65	0.00	0.11	0.41	0.32	0.11	0.12	0.64	0.57
Avail Cap(c_a), veh/h	1223	1284	1088	1584	0	1355	581	1831	1552	241	1473	1221
HCM Platoon Ratio	1.00	1.00	1.00	1.00	1.00	1.00	1.00	1.00	1.00	1.00	1.00	1.00
Upstream Filter(I)	1.00	1.00	1.00	1.00	0.00	1.00	1.00	1.00	1.00	1.00	1.00	1.00
Uniform Delay (d), s/veh	16.2	16.7	15.9	19.1	0.0	18.0	18.5	14.5	13.8	17.7	15.6	15.3
Incr Delay (d2), s/veh	0.9	1.7	0.7	3.7	0.0	0.3	1.4	0.4	0.1	0.3	1.6	1.5
Initial Q Delay(d3),s/veh	0.0	0.0	0.0	0.0	0.0	0.0	0.0	0.0	0.0	0.0	0.0	0.0
%ile BackOfQ(50%),veh/ln	1.0	1.7	0.7	1.2	0.0	0.1	0.7	0.9	0.2	0.2	2.2	1.6
Unsig. Movement Delay, s/veh												
LnGrp Delay(d),s/veh	17.0	18.4	16.6	22.8	0.0	18.3	19.9	14.9	13.9	18.0	17.2	16.8
LnGrp LOS	B	B	B	C	A	B	B	B	B	B	B	B
Approach Vol, veh/h		427			143			248			494	
Approach Delay, s/veh		17.6			22.2			16.4			17.1	
Approach LOS		B			C			B			B	
Timer - Assigned Phs		2	3	4		6	7	8				
Phs Duration (G+Y+Rc), s		12.5	8.3	14.5		9.1	8.5	14.3				
Change Period (Y+Rc), s		4.5	3.5	4.5		4.5	3.5	4.5				
Max Green Setting (Gmax), s		30.5	14.5	35.0		38.0	6.0	43.5				
Max Q Clear Time (g_c+I1), s		6.3	3.9	7.8		4.9	2.5	4.6				
Green Ext Time (p_c), s		1.7	0.1	2.2		0.7	0.0	0.8				
<b>Intersection Summary</b>												
HCM 6th Ctrl Delay				17.7								
HCM 6th LOS				B								

HCM Signalized Intersection Capacity Analysis  
2: Shiloh Road & Hembree Ln

Existing Project Alter. C Conditions  
Timing Plan: A.M. PEAK



Movement	EBL	EBT	WBT	WBR	SBL	SBR
Lane Configurations	↖ ↗	↑	↖ ↗		↖	↗
Traffic Volume (vph)	305	294	292	68	71	361
Future Volume (vph)	305	294	292	68	71	361
Ideal Flow (vphpl)	1900	1900	1900	1900	1900	1900
Total Lost time (s)	4.0	4.0	4.0		4.0	4.0
Lane Util. Factor	0.97	1.00	0.95		1.00	1.00
Frt	1.00	1.00	0.97		1.00	0.85
Flt Protected	0.95	1.00	1.00		0.95	1.00
Satd. Flow (prot)	3433	1863	3439		1770	1583
Flt Permitted	0.95	1.00	1.00		0.95	1.00
Satd. Flow (perm)	3433	1863	3439		1770	1583
Peak-hour factor, PHF	0.88	0.88	0.97	0.97	0.94	0.94
Adj. Flow (vph)	347	334	301	70	76	384
RTOR Reduction (vph)	0	0	29	0	0	234
Lane Group Flow (vph)	347	334	342	0	76	150
Turn Type	Prot	NA	NA		Perm	pm+ov
Protected Phases	5	2	6			5
Permitted Phases					4	4 5
Actuated Green, G (s)	10.4	24.9	10.5		4.1	14.5
Effective Green, g (s)	10.4	24.9	10.5		4.1	14.5
Actuated g/C Ratio	0.28	0.67	0.28		0.11	0.39
Clearance Time (s)	4.0	4.0	4.0		4.0	4.0
Vehicle Extension (s)	3.0	3.0	3.0		3.0	3.0
Lane Grp Cap (vph)	964	1253	975		196	791
v/s Ratio Prot	c0.10	0.18	c0.10			0.05
v/s Ratio Perm					c0.04	0.04
v/c Ratio	0.36	0.27	0.35		0.39	0.19
Uniform Delay, d1	10.6	2.4	10.5		15.3	7.4
Progression Factor	1.00	1.00	1.00		1.00	1.00
Incremental Delay, d2	0.2	0.1	0.2		1.3	0.1
Delay (s)	10.9	2.5	10.8		16.6	7.5
Level of Service	B	A	B		B	A
Approach Delay (s)		6.8	10.8		9.0	
Approach LOS		A	B		A	

Intersection Summary				
HCM 2000 Control Delay		8.4	HCM 2000 Level of Service	A
HCM 2000 Volume to Capacity ratio		0.36		
Actuated Cycle Length (s)		37.0	Sum of lost time (s)	12.0
Intersection Capacity Utilization		39.3%	ICU Level of Service	A
Analysis Period (min)		15		

c Critical Lane Group

HCM 6th Signalized Intersection Summary  
 3: US 101 NB Off-Ramp & Shiloh Road

Existing Project Alter. C Conditions  
 Timing Plan: A.M. PEAK



Movement	EBT	EBR	WBL	WBT	NBL	NBR
Lane Configurations	↑↑			↑	↘	↗↗
Traffic Volume (veh/h)	246	0	0	515	432	366
Future Volume (veh/h)	246	0	0	515	432	366
Initial Q (Qb), veh	0	0	0	0	0	0
Ped-Bike Adj(A_pbT)		1.00	1.00		1.00	1.00
Parking Bus, Adj	1.00	1.00	1.00	1.00	1.00	1.00
Work Zone On Approach	No			No	No	
Adj Sat Flow, veh/h/ln	1870	0	0	1870	1870	1870
Adj Flow Rate, veh/h	270	0	0	572	568	482
Peak Hour Factor	0.91	0.91	0.90	0.90	0.76	0.76
Percent Heavy Veh, %	2	0	0	2	2	2
Cap, veh/h	1405	0	0	739	738	1156
Arrive On Green	0.40	0.00	0.00	0.40	0.41	0.41
Sat Flow, veh/h	3741	0	0	1870	1781	2790
Grp Volume(v), veh/h	270	0	0	572	568	482
Grp Sat Flow(s),veh/h/ln	1777	0	0	1870	1781	1395
Q Serve(g_s), s	2.1	0.0	0.0	11.2	11.5	5.1
Cycle Q Clear(g_c), s	2.1	0.0	0.0	11.2	11.5	5.1
Prop In Lane		0.00	0.00		1.00	1.00
Lane Grp Cap(c), veh/h	1405	0	0	739	738	1156
V/C Ratio(X)	0.19	0.00	0.00	0.77	0.77	0.42
Avail Cap(c_a), veh/h	2791	0	0	1469	1314	2058
HCM Platoon Ratio	1.00	1.00	1.00	1.00	1.00	1.00
Upstream Filter(I)	1.00	0.00	0.00	1.00	1.00	1.00
Uniform Delay (d), s/veh	8.3	0.0	0.0	11.1	10.6	8.7
Incr Delay (d2), s/veh	0.1	0.0	0.0	1.8	1.7	0.2
Initial Q Delay(d3),s/veh	0.0	0.0	0.0	0.0	0.0	0.0
%ile BackOfQ(50%),veh/ln	0.6	0.0	0.0	3.4	3.7	1.2
Unsig. Movement Delay, s/veh						
LnGrp Delay(d),s/veh	8.4	0.0	0.0	12.8	12.3	9.0
LnGrp LOS	A	A	A	B	B	A
Approach Vol, veh/h	270			572	1050	
Approach Delay, s/veh	8.4			12.8	10.8	
Approach LOS	A			B	B	
Timer - Assigned Phs		2			6	8
Phs Duration (G+Y+Rc), s		20.6			20.6	21.4
Change Period (Y+Rc), s		4.0			4.0	4.0
Max Green Setting (Gmax), s		33.0			33.0	31.0
Max Q Clear Time (g_c+I1), s		4.1			13.2	13.5
Green Ext Time (p_c), s		1.6			3.4	3.9
<b>Intersection Summary</b>						
HCM 6th Ctrl Delay			11.1			
HCM 6th LOS			B			



HCM Signalized Intersection Capacity Analysis  
4: Shiloh Road & US 101 SB Off-Ramp

Existing Project Alter. C Conditions  
Timing Plan: A.M. PEAK



Movement	EBL	EBT	WBT	WBR	SBL	SBR
Lane Configurations		↑	↑		↘	↗
Traffic Volume (vph)	0	231	587	0	103	138
Future Volume (vph)	0	231	587	0	103	138
Ideal Flow (vphpl)	1900	1900	1900	1900	1900	1900
Total Lost time (s)		4.0	4.0		4.0	4.0
Lane Util. Factor		1.00	1.00		1.00	1.00
Frt		1.00	1.00		1.00	0.85
Flt Protected		1.00	1.00		0.95	1.00
Satd. Flow (prot)		1863	1863		1770	1583
Flt Permitted		1.00	1.00		0.95	1.00
Satd. Flow (perm)		1863	1863		1770	1583
Peak-hour factor, PHF	0.93	0.93	0.91	0.91	0.92	0.92
Adj. Flow (vph)	0	248	645	0	112	150
RTOR Reduction (vph)	0	0	0	0	0	123
Lane Group Flow (vph)	0	248	645	0	112	27
Turn Type		NA	NA		Perm	Perm
Protected Phases		2	6			
Permitted Phases					4	4
Actuated Green, G (s)		19.2	19.2		5.9	5.9
Effective Green, g (s)		19.2	19.2		5.9	5.9
Actuated g/C Ratio		0.58	0.58		0.18	0.18
Clearance Time (s)		4.0	4.0		4.0	4.0
Vehicle Extension (s)		3.0	3.0		3.0	3.0
Lane Grp Cap (vph)		1080	1080		315	282
v/s Ratio Prot		0.13	c0.35			
v/s Ratio Perm					c0.06	0.02
v/c Ratio		0.23	0.60		0.36	0.09
Uniform Delay, d1		3.4	4.5		11.9	11.4
Progression Factor		1.00	1.00		1.00	1.00
Incremental Delay, d2		0.1	0.9		0.7	0.1
Delay (s)		3.5	5.4		12.6	11.5
Level of Service		A	A		B	B
Approach Delay (s)		3.5	5.4		12.0	
Approach LOS		A	A		B	

Intersection Summary			
HCM 2000 Control Delay	6.5	HCM 2000 Level of Service	A
HCM 2000 Volume to Capacity ratio	0.54		
Actuated Cycle Length (s)	33.1	Sum of lost time (s)	8.0
Intersection Capacity Utilization	56.1%	ICU Level of Service	B
Analysis Period (min)	15		

c Critical Lane Group

Intersection						
Int Delay, s/veh	2.6					
Movement	EBT	EBR	WBL	WBT	NBL	NBR
Lane Configurations	↑↑		↘	↑	↘	↘
Traffic Vol, veh/h	523	22	177	550	7	121
Future Vol, veh/h	523	22	177	550	7	121
Conflicting Peds, #/hr	0	0	0	0	0	0
Sign Control	Free	Free	Free	Free	Stop	Stop
RT Channelized	-	None	-	None	-	None
Storage Length	-	-	68	-	0	0
Veh in Median Storage, #	0	-	-	0	0	-
Grade, %	0	-	-	0	0	-
Peak Hour Factor	96	96	87	87	84	84
Heavy Vehicles, %	2	2	2	2	2	2
Mvmt Flow	545	23	203	632	8	144

Major/Minor	Major1	Major2	Minor1		
Conflicting Flow All	0	0	568	0	1595 284
Stage 1	-	-	-	-	557 -
Stage 2	-	-	-	-	1038 -
Critical Hdwy	-	-	4.13	-	6.63 6.93
Critical Hdwy Stg 1	-	-	-	-	5.83 -
Critical Hdwy Stg 2	-	-	-	-	5.43 -
Follow-up Hdwy	-	-	2.219	-	3.519 3.319
Pot Cap-1 Maneuver	-	-	1002	-	107 714
Stage 1	-	-	-	-	538 -
Stage 2	-	-	-	-	340 -
Platoon blocked, %	-	-	-	-	-
Mov Cap-1 Maneuver	-	-	1002	-	85 714
Mov Cap-2 Maneuver	-	-	-	-	85 -
Stage 1	-	-	-	-	538 -
Stage 2	-	-	-	-	271 -

Approach	EB	WB	NB
HCM Control Delay, s	0	2.3	13.5
HCM LOS			B

Minor Lane/Major Mvmt	NBLn1	NBLn2	EBT	EBR	WBL	WBT
Capacity (veh/h)	85	714	-	-	1002	-
HCM Lane V/C Ratio	0.098	0.202	-	-	0.203	-
HCM Control Delay (s)	51.9	11.3	-	-	9.5	-
HCM Lane LOS	F	B	-	-	A	-
HCM 95th %tile Q(veh)	0.3	0.8	-	-	0.8	-

HCM Signalized Intersection Capacity Analysis  
6: Conde Lane & Shiloh Road

Existing Project Alter. C Conditions  
Timing Plan: A.M. PEAK

Movement	EBL	EBT	EBR	WBL	WBT	WBR	NBL	NBT	NBR	SBL	SBT	SBR
Lane Configurations												
Traffic Volume (vph)	25	328	5	9	354	204	4	0	12	205	1	35
Future Volume (vph)	25	328	5	9	354	204	4	0	12	205	1	35
Ideal Flow (vphpl)	1900	1900	1900	1900	1900	1900	1900	1900	1900	1900	1900	1900
Total Lost time (s)	4.0	4.0		4.0	4.0			4.0			4.0	4.0
Lane Util. Factor	1.00	0.95		1.00	0.95			1.00			1.00	1.00
Frt	1.00	1.00		1.00	0.95			0.90			1.00	0.85
Flt Protected	0.95	1.00		0.95	1.00			0.99			0.95	1.00
Satd. Flow (prot)	1770	3532		1770	3345			1653			1774	1583
Flt Permitted	0.95	1.00		0.95	1.00			0.99			0.95	1.00
Satd. Flow (perm)	1770	3532		1770	3345			1653			1774	1583
Peak-hour factor, PHF	0.95	0.95	0.95	0.85	0.85	0.85	0.57	0.57	0.57	0.86	0.86	0.86
Adj. Flow (vph)	26	345	5	11	416	240	7	0	21	238	1	41
RTOR Reduction (vph)	0	1	0	0	82	0	0	26	0	0	0	0
Lane Group Flow (vph)	26	349	0	11	574	0	0	2	0	0	239	41
Turn Type	Prot	NA		Prot	NA		Split	NA		Split	NA	custom
Protected Phases	5	2		1	6		7	7		4	4	
Permitted Phases												6
Actuated Green, G (s)	2.1	16.4		1.0	15.3			2.7			12.8	15.3
Effective Green, g (s)	2.1	16.4		1.0	15.3			2.7			12.8	15.3
Actuated g/C Ratio	0.04	0.34		0.02	0.31			0.06			0.26	0.31
Clearance Time (s)	4.0	4.0		4.0	4.0			4.0			4.0	4.0
Vehicle Extension (s)	3.0	3.0		3.0	3.0			3.0			3.0	3.0
Lane Grp Cap (vph)	76	1184		36	1046			91			464	495
v/s Ratio Prot	c0.01	0.10		0.01	c0.17			c0.00			c0.13	
v/s Ratio Perm												0.03
v/c Ratio	0.34	0.30		0.31	0.55			0.02			0.52	0.08
Uniform Delay, d1	22.7	12.0		23.6	13.9			21.8			15.4	11.9
Progression Factor	1.00	1.00		1.00	1.00			1.00			1.00	1.00
Incremental Delay, d2	2.7	0.1		4.8	0.6			0.1			1.0	0.1
Delay (s)	25.4	12.1		28.4	14.5			21.9			16.4	11.9
Level of Service	C	B		C	B			C			B	B
Approach Delay (s)		13.0			14.8			21.9			15.7	
Approach LOS		B			B			C			B	
<b>Intersection Summary</b>												
HCM 2000 Control Delay			14.6			HCM 2000 Level of Service				B		
HCM 2000 Volume to Capacity ratio			0.48									
Actuated Cycle Length (s)			48.9			Sum of lost time (s)			16.0			
Intersection Capacity Utilization			45.5%			ICU Level of Service			A			
Analysis Period (min)			15									

c Critical Lane Group

HCM 6th TWSC  
7: Entrance 1/Gridley Drive & Shiloh Road

Existing Project Alter. C Conditions  
Timing Plan: A.M. PEAK

Intersection												
Int Delay, s/veh	2.2											
Movement	EBL	EBT	EBR	WBL	WBT	WBR	NBL	NBT	NBR	SBL	SBT	SBR
Lane Configurations		↕			↕		↕	↕			↕	
Traffic Vol, veh/h	8	141	64	5	58	0	42	0	3	1	0	16
Future Vol, veh/h	8	141	64	5	58	0	42	0	3	1	0	16
Conflicting Peds, #/hr	0	0	0	0	0	0	0	0	0	0	0	0
Sign Control	Free	Free	Free	Free	Free	Free	Stop	Stop	Stop	Stop	Stop	Stop
RT Channelized	-	-	None	-	-	None	-	-	None	-	-	None
Storage Length	-	-	-	-	-	-	0	-	-	-	-	-
Veh in Median Storage, #	-	0	-	-	0	-	-	0	-	-	0	-
Grade, %	-	0	-	-	0	-	-	0	-	-	0	-
Peak Hour Factor	91	91	91	85	85	85	100	100	100	71	71	71
Heavy Vehicles, %	2	2	2	2	2	2	2	2	2	2	2	2
Mvmt Flow	9	155	70	6	68	0	42	0	3	1	0	23

Major/Minor	Major1			Major2			Minor1			Minor2		
Conflicting Flow All	68	0	0	225	0	0	300	288	190	290	323	68
Stage 1	-	-	-	-	-	-	208	208	-	80	80	-
Stage 2	-	-	-	-	-	-	92	80	-	210	243	-
Critical Hdwy	4.12	-	-	4.12	-	-	7.12	6.52	6.22	7.12	6.52	6.22
Critical Hdwy Stg 1	-	-	-	-	-	-	6.12	5.52	-	6.12	5.52	-
Critical Hdwy Stg 2	-	-	-	-	-	-	6.12	5.52	-	6.12	5.52	-
Follow-up Hdwy	2.218	-	-	2.218	-	-	3.518	4.018	3.318	3.518	4.018	3.318
Pot Cap-1 Maneuver	1533	-	-	1344	-	-	652	622	852	662	595	995
Stage 1	-	-	-	-	-	-	794	730	-	929	828	-
Stage 2	-	-	-	-	-	-	915	828	-	792	705	-
Platoon blocked, %		-	-		-	-						
Mov Cap-1 Maneuver	1533	-	-	1344	-	-	631	615	852	653	588	995
Mov Cap-2 Maneuver	-	-	-	-	-	-	631	615	-	653	588	-
Stage 1	-	-	-	-	-	-	788	725	-	922	824	-
Stage 2	-	-	-	-	-	-	890	824	-	784	700	-

Approach	EB			WB			NB			SB		
HCM Control Delay, s	0.3			0.6			11			8.8		
HCM LOS							B			A		

Minor Lane/Major Mvmt	NBLn1	NBLn2	EBL	EBT	EBR	WBL	WBT	WBR	SBLn1
Capacity (veh/h)	631	852	1533	-	-	1344	-	-	965
HCM Lane V/C Ratio	0.067	0.004	0.006	-	-	0.004	-	-	0.025
HCM Control Delay (s)	11.1	9.2	7.4	0	-	7.7	0	-	8.8
HCM Lane LOS	B	A	A	A	-	A	A	-	A
HCM 95th %tile Q(veh)	0.2	0	0	-	-	0	-	-	0.1

HCM 6th TWSC  
8: Old Redwood Hwy & Entrance 1

Existing Project Alter. C Conditions  
Timing Plan: A.M. PEAK

Intersection												
Int Delay, s/veh	0.6											
Movement	EBL	EBT	EBR	WBL	WBT	WBR	NBL	NBT	NBR	SBL	SBT	SBR
Lane Configurations		↕		↕	↕			↕		↕	↕	
Traffic Vol, veh/h	1	0	0	6	0	10	0	217	9	15	316	0
Future Vol, veh/h	1	0	0	6	0	10	0	217	9	15	316	0
Conflicting Peds, #/hr	0	0	0	0	0	0	0	0	1	1	0	0
Sign Control	Stop	Stop	Stop	Stop	Stop	Stop	Free	Free	Free	Free	Free	Free
RT Channelized	-	-	None	-	-	None	-	-	None	-	-	None
Storage Length	-	-	-	0	-	-	-	-	-	50	-	-
Veh in Median Storage, #	-	0	-	-	0	-	-	0	-	-	0	-
Grade, %	-	0	-	-	0	-	-	0	-	-	0	-
Peak Hour Factor	25	25	25	100	100	100	99	99	99	90	90	90
Heavy Vehicles, %	2	2	2	2	2	2	2	2	2	2	2	2
Mvmt Flow	4	0	0	6	0	10	0	219	9	17	351	0

Major/Minor	Minor2		Minor1		Major1		Major2					
Conflicting Flow All	614	614	351	610	610	225	351	0	0	229	0	0
Stage 1	385	385	-	225	225	-	-	-	-	-	-	-
Stage 2	229	229	-	385	385	-	-	-	-	-	-	-
Critical Hdwy	7.12	6.52	6.22	7.12	6.52	6.22	4.12	-	-	4.12	-	-
Critical Hdwy Stg 1	6.12	5.52	-	6.12	5.52	-	-	-	-	-	-	-
Critical Hdwy Stg 2	6.12	5.52	-	6.12	5.52	-	-	-	-	-	-	-
Follow-up Hdwy	3.518	4.018	3.318	3.518	4.018	3.318	2.218	-	-	2.218	-	-
Pot Cap-1 Maneuver	404	407	692	407	409	814	1208	-	-	1339	-	-
Stage 1	638	611	-	778	718	-	-	-	-	-	-	-
Stage 2	774	715	-	638	611	-	-	-	-	-	-	-
Platoon blocked, %								-	-	-	-	-
Mov Cap-1 Maneuver	395	401	692	403	403	813	1208	-	-	1338	-	-
Mov Cap-2 Maneuver	395	401	-	403	403	-	-	-	-	-	-	-
Stage 1	638	603	-	777	717	-	-	-	-	-	-	-
Stage 2	764	714	-	630	603	-	-	-	-	-	-	-

Approach	EB		WB		NB		SB	
HCM Control Delay, s	14.2		11.2		0		0.4	
HCM LOS	B		B					

Minor Lane/Major Mvmt	NBL	NBT	NBR	EBLn1	WBLn1	WBLn2	SBL	SBT	SBR
Capacity (veh/h)	1208	-	-	395	403	813	1338	-	-
HCM Lane V/C Ratio	-	-	-	0.01	0.015	0.012	0.012	-	-
HCM Control Delay (s)	0	-	-	14.2	14.1	9.5	7.7	-	-
HCM Lane LOS	A	-	-	B	B	A	A	-	-
HCM 95th %tile Q(veh)	0	-	-	0	0	0	0	-	-

Intersection						
Int Delay, s/veh	0					
Movement	EBT	EBR	WBL	WBT	NBL	NBR
Lane Configurations	↔			↔	↔	↔
Traffic Vol, veh/h	143	0	0	57	0	0
Future Vol, veh/h	143	0	0	57	0	0
Conflicting Peds, #/hr	0	0	0	0	0	0
Sign Control	Free	Free	Free	Free	Stop	Stop
RT Channelized	-	None	-	None	-	None
Storage Length	-	-	-	-	0	0
Veh in Median Storage, #	0	-	-	0	0	-
Grade, %	0	-	-	0	0	-
Peak Hour Factor	85	85	81	81	100	100
Heavy Vehicles, %	2	2	2	2	2	2
Mvmt Flow	168	0	0	70	0	0

Major/Minor	Major1	Major2	Minor1		
Conflicting Flow All	0	0	168	0	238
Stage 1	-	-	-	-	168
Stage 2	-	-	-	-	70
Critical Hdwy	-	-	4.12	-	6.42
Critical Hdwy Stg 1	-	-	-	-	5.42
Critical Hdwy Stg 2	-	-	-	-	5.42
Follow-up Hdwy	-	-	2.218	-	3.518
Pot Cap-1 Maneuver	-	-	1410	-	750
Stage 1	-	-	-	-	862
Stage 2	-	-	-	-	953
Platoon blocked, %	-	-	-	-	-
Mov Cap-1 Maneuver	-	-	1410	-	750
Mov Cap-2 Maneuver	-	-	-	-	750
Stage 1	-	-	-	-	862
Stage 2	-	-	-	-	953

Approach	EB	WB	NB
HCM Control Delay, s	0	0	0
HCM LOS			A

Minor Lane/Major Mvmt	NBLn1	NBLn2	EBT	EBR	WBL	WBT
Capacity (veh/h)	-	-	-	-	1410	-
HCM Lane V/C Ratio	-	-	-	-	-	-
HCM Control Delay (s)	0	0	-	-	0	-
HCM Lane LOS	A	A	-	-	A	-
HCM 95th %tile Q(veh)	-	-	-	-	0	-

HCM 6th Signalized Intersection Summary  
 10: US 101 NB Off Ramp/Lakewood Drive & Old Redwood Highway

Existing Project Alter. C Conditions  
 Timing Plan: A.M. PEAK



Movement	EBL	EBT	EBR	WBL	WBT	WBR	NBL	NBT	NBR	SBL	SBT	SBR
Lane Configurations	↔↔	↑			↑↑		↔	↔↔		↔↔		↔
Traffic Volume (veh/h)	152	158	0	0	446	149	227	221	79	118	0	534
Future Volume (veh/h)	152	158	0	0	446	149	227	221	79	118	0	534
Initial Q (Qb), veh	0	0	0	0	0	0	0	0	0	0	0	0
Ped-Bike Adj(A_pbT)	1.00		1.00	1.00		0.99	1.00		1.00	1.00		1.00
Parking Bus, Adj	1.00	1.00	1.00	1.00	1.00	1.00	1.00	1.00	1.00	1.00	1.00	1.00
Work Zone On Approach		No			No			No			No	
Adj Sat Flow, veh/h/ln	1870	1870	0	0	1870	1870	1870	1870	1870	1870	0	1870
Adj Flow Rate, veh/h	179	186	0	0	537	180	195	325	88	133	0	0
Peak Hour Factor	0.85	0.85	0.85	0.83	0.83	0.83	0.90	0.90	0.90	0.89	0.89	0.89
Percent Heavy Veh, %	2	2	0	0	2	2	2	2	2	2	0	2
Cap, veh/h	373	1215	0	0	1244	415	342	546	145	0	0	
Arrive On Green	0.11	0.65	0.00	0.00	0.48	0.48	0.19	0.19	0.19	0.00	0.00	0.00
Sat Flow, veh/h	3456	1870	0	0	2700	870	1781	2844	758		0	
Grp Volume(v), veh/h	179	186	0	0	365	352	195	212	201		0.0	
Grp Sat Flow(s),veh/h/ln	1728	1870	0	0	1777	1700	1781	1870	1731			
Q Serve(g_s), s	3.0	2.4	0.0	0.0	8.4	8.4	6.1	6.4	6.6			
Cycle Q Clear(g_c), s	3.0	2.4	0.0	0.0	8.4	8.4	6.1	6.4	6.6			
Prop In Lane	1.00		0.00	0.00		0.51	1.00		0.44			
Lane Grp Cap(c), veh/h	373	1215	0	0	848	811	342	359	332			
V/C Ratio(X)	0.48	0.15	0.00	0.00	0.43	0.43	0.57	0.59	0.61			
Avail Cap(c_a), veh/h	503	1215	0	0	848	811	835	877	811			
HCM Platoon Ratio	1.00	1.00	1.00	1.00	1.00	1.00	1.00	1.00	1.00			
Upstream Filter(I)	1.00	1.00	0.00	0.00	1.00	1.00	1.00	1.00	1.00			
Uniform Delay (d), s/veh	26.0	4.2	0.0	0.0	10.6	10.7	22.7	22.8	22.9			
Incr Delay (d2), s/veh	1.0	0.3	0.0	0.0	1.6	1.7	1.5	1.5	1.8			
Initial Q Delay(d3),s/veh	0.0	0.0	0.0	0.0	0.0	0.0	0.0	0.0	0.0			
%ile BackOfQ(50%),veh/ln	1.2	0.7	0.0	0.0	3.1	3.0	2.5	2.8	2.7			
Unsig. Movement Delay, s/veh												
LnGrp Delay(d),s/veh	26.9	4.5	0.0	0.0	12.2	12.4	24.2	24.3	24.6			
LnGrp LOS	C	A	A	A	B	B	C	C	C			
Approach Vol, veh/h		365			717			608				
Approach Delay, s/veh		15.5			12.3			24.4				
Approach LOS		B			B			C				
Timer - Assigned Phs		2			5	6		8				
Phs Duration (G+Y+Rc), s		45.3			10.7	34.6		16.6				
Change Period (Y+Rc), s		5.1			4.0	5.1		4.7				
Max Green Setting (Gmax), s		40.2			9.0	27.2		29.0				
Max Q Clear Time (g_c+I1), s		4.4			5.0	10.4		8.6				
Green Ext Time (p_c), s		1.1			0.2	4.1		3.0				

Intersection Summary

HCM 6th Ctrl Delay	17.3
HCM 6th LOS	B

Notes

User approved volume balancing among the lanes for turning movement.  
 Unsignalized Delay for [SBR] is excluded from calculations of the approach delay and intersection delay.

HCM 6th Signalized Intersection Summary

Existing Project Alter. C Conditions

12: US 101 SB On Ramp/US 101 SB Off Ramp & Old Redwood Highway

Timing Plan: A.M. PEAK



Movement	EBL	EBT	EBR	WBL	WBT	WBR	NBL	NBT	NBR	SBL	SBT	SBR
Lane Configurations		↑↑	↗	↘	↑↑					↘	↕	
Traffic Volume (veh/h)	0	298	296	513	504	0	0	0	0	101	1	65
Future Volume (veh/h)	0	298	296	513	504	0	0	0	0	101	1	65
Initial Q (Qb), veh	0	0	0	0	0	0				0	0	0
Ped-Bike Adj(A_pbT)	1.00		0.98	1.00		1.00				1.00		1.00
Parking Bus, Adj	1.00	1.00	1.00	1.00	1.00	1.00				1.00	1.00	1.00
Work Zone On Approach		No			No						No	
Adj Sat Flow, veh/h/ln	0	1870	1870	1870	1870	0				1870	1870	1870
Adj Flow Rate, veh/h	0	324	322	576	566	0				103	32	0
Peak Hour Factor	0.92	0.92	0.92	0.89	0.89	0.89				0.81	0.81	0.81
Percent Heavy Veh, %	0	2	2	2	2	0				2	2	2
Cap, veh/h	0	1288	565	614	2691	0				213	223	
Arrive On Green	0.00	0.36	0.36	0.34	0.76	0.00				0.12	0.12	0.00
Sat Flow, veh/h	0	3647	1560	1781	3647	0				1781	1870	0
Grp Volume(v), veh/h	0	324	322	576	566	0				103	32	0
Grp Sat Flow(s),veh/h/ln	0	1777	1560	1781	1777	0				1781	1870	0
Q Serve(g_s), s	0.0	5.1	13.2	24.9	3.7	0.0				4.3	1.2	0.0
Cycle Q Clear(g_c), s	0.0	5.1	13.2	24.9	3.7	0.0				4.3	1.2	0.0
Prop In Lane	0.00		1.00	1.00		0.00				1.00		0.00
Lane Grp Cap(c), veh/h	0	1288	565	614	2691	0				213	223	
V/C Ratio(X)	0.00	0.25	0.57	0.94	0.21	0.00				0.48	0.14	
Avail Cap(c_a), veh/h	0	1288	565	650	2691	0				224	235	
HCM Platoon Ratio	1.00	1.00	1.00	1.00	1.00	1.00				1.00	1.00	1.00
Upstream Filter(I)	0.00	1.00	1.00	1.00	1.00	0.00				1.00	1.00	0.00
Uniform Delay (d), s/veh	0.0	17.8	20.4	25.2	2.8	0.0				32.7	31.4	0.0
Incr Delay (d2), s/veh	0.0	0.5	4.1	20.9	0.2	0.0				1.7	0.3	0.0
Initial Q Delay(d3),s/veh	0.0	0.0	0.0	0.0	0.0	0.0				0.0	0.0	0.0
%ile BackOfQ(50%),veh/ln	0.0	2.0	5.1	13.2	0.8	0.0				1.9	0.6	0.0
Unsig. Movement Delay, s/veh												
LnGrp Delay(d),s/veh	0.0	18.2	24.5	46.1	3.0	0.0				34.4	31.6	0.0
LnGrp LOS	A	B	C	D	A	A				C	C	
Approach Vol, veh/h		646			1142							135
Approach Delay, s/veh		21.4			24.7							33.8
Approach LOS		C			C							C
Timer - Assigned Phs		2			5	6			8			
Phs Duration (G+Y+Rc), s		65.3			31.4	33.9			14.2			
Change Period (Y+Rc), s		5.1			4.0	5.1			4.7			
Max Green Setting (Gmax), s		60.2			29.0	27.2			10.0			
Max Q Clear Time (g_c+I1), s		5.7			26.9	15.2			6.3			
Green Ext Time (p_c), s		4.2			0.5	2.6			0.1			

Intersection Summary

HCM 6th Ctrl Delay	24.2
HCM 6th LOS	C























Notes

- User approved volume balancing among the lanes for turning movement.
- User approved ignoring U-Turning movement.
- Unsignalized Delay for [SBR] is excluded from calculations of the approach delay and intersection delay.



HCM 6th Signalized Intersection Summary  
 1: Old Redwood Hwy & Shiloh Road

Existing Project Alter. C Conditions  
 Timing Plan: P.M. Peak

												
Movement	EBL	EBT	EBR	WBL	WBT	WBR	NBL	NBT	NBR	SBL	SBT	SBR
Lane Configurations												
Traffic Volume (veh/h)	241	146	174	37	137	23	153	339	21	31	235	146
Future Volume (veh/h)	241	146	174	37	137	23	153	339	21	31	235	146
Initial Q (Qb), veh	0	0	0	0	0	0	0	0	0	0	0	0
Ped-Bike Adj(A_pbT)	1.00		1.00	1.00		1.00	1.00		0.97	1.00		0.97
Parking Bus, Adj	1.00	1.00	1.00	1.00	1.00	1.00	1.00	1.00	1.00	1.00	1.00	1.00
Work Zone On Approach		No			No			No			No	
Adj Sat Flow, veh/h/ln	1870	1870	1870	1870	1870	1870	1870	1870	1870	1870	1870	1870
Adj Flow Rate, veh/h	248	151	179	41	151	25	165	365	23	33	253	157
Peak Hour Factor	0.97	0.97	0.97	0.91	0.91	0.91	0.93	0.93	0.93	0.93	0.93	0.93
Percent Heavy Veh, %	2	2	2	2	2	2	2	2	2	2	2	2
Cap, veh/h	361	379	320	60	221	240	228	486	401	156	410	338
Arrive On Green	0.20	0.20	0.20	0.15	0.15	0.15	0.13	0.26	0.26	0.09	0.22	0.22
Sat Flow, veh/h	1781	1870	1581	395	1455	1580	1781	1870	1544	1781	1870	1542
Grp Volume(v), veh/h	248	151	179	192	0	25	165	365	23	33	253	157
Grp Sat Flow(s),veh/h/ln	1781	1870	1581	1851	0	1580	1781	1870	1544	1781	1870	1542
Q Serve(g_s), s	7.4	4.0	5.8	5.6	0.0	0.8	5.1	10.2	0.6	1.0	7.0	5.0
Cycle Q Clear(g_c), s	7.4	4.0	5.8	5.6	0.0	0.8	5.1	10.2	0.6	1.0	7.0	5.0
Prop In Lane	1.00		1.00	0.21		1.00	1.00		1.00	1.00		1.00
Lane Grp Cap(c), veh/h	361	379	320	281	0	240	228	486	401	156	410	338
V/C Ratio(X)	0.69	0.40	0.56	0.68	0.00	0.10	0.72	0.75	0.06	0.21	0.62	0.46
Avail Cap(c_a), veh/h	953	1000	846	1233	0	1053	453	1427	1178	187	1148	946
HCM Platoon Ratio	1.00	1.00	1.00	1.00	1.00	1.00	1.00	1.00	1.00	1.00	1.00	1.00
Upstream Filter(I)	1.00	1.00	1.00	1.00	0.00	1.00	1.00	1.00	1.00	1.00	1.00	1.00
Uniform Delay (d), s/veh	21.1	19.7	20.4	22.9	0.0	20.8	23.9	19.4	15.9	24.2	20.1	19.3
Incr Delay (d2), s/veh	2.3	0.7	1.5	2.9	0.0	0.2	4.3	2.4	0.1	0.7	1.5	1.0
Initial Q Delay(d3),s/veh	0.0	0.0	0.0	0.0	0.0	0.0	0.0	0.0	0.0	0.0	0.0	0.0
%ile BackOfQ(50%),veh/ln	2.9	1.6	2.0	2.4	0.0	0.3	2.1	4.0	0.2	0.4	2.8	1.7
Unsig. Movement Delay, s/veh												
LnGrp Delay(d),s/veh	23.4	20.4	22.0	25.8	0.0	21.0	28.2	21.8	15.9	24.8	21.6	20.3
LnGrp LOS	C	C	C	C	A	C	C	C	B	C	C	C
Approach Vol, veh/h		578			217			553			443	
Approach Delay, s/veh		22.2			25.3			23.5			21.4	
Approach LOS		C			C			C			C	
Timer - Assigned Phs		2	3	4		6	7	8				
Phs Duration (G+Y+Rc), s		16.1	10.8	17.0		13.2	8.5	19.3				
Change Period (Y+Rc), s		4.5	3.5	4.5		4.5	3.5	4.5				
Max Green Setting (Gmax), s		30.5	14.5	35.0		38.0	6.0	43.5				
Max Q Clear Time (g_c+I1), s		9.4	7.1	9.0		7.6	3.0	12.2				
Green Ext Time (p_c), s		2.1	0.2	1.9		1.1	0.0	2.1				
<b>Intersection Summary</b>												
HCM 6th Ctrl Delay				22.7								
HCM 6th LOS				C								

# HCM Signalized Intersection Capacity Analysis

## 2: Shiloh Road & Hembree Ln

Existing Project Alter. C Conditions

Timing Plan: P.M. Peak

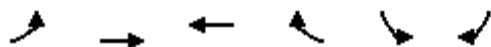

Movement	EBL	EBT	WBT	WBR	SBL	SBR
Lane Configurations	↔↔	↑	↑↔		↔	↔
Traffic Volume (vph)	615	410	320	141	170	491
Future Volume (vph)	615	410	320	141	170	491
Ideal Flow (vphpl)	1900	1900	1900	1900	1900	1900
Total Lost time (s)	4.0	4.0	4.0		4.0	4.0
Lane Util. Factor	0.97	1.00	0.95		1.00	1.00
Frbp, ped/bikes	1.00	1.00	1.00		1.00	1.00
Flpb, ped/bikes	1.00	1.00	1.00		1.00	1.00
Frt	1.00	1.00	0.95		1.00	0.85
Flt Protected	0.95	1.00	1.00		0.95	1.00
Satd. Flow (prot)	3433	1863	3364		1770	1583
Flt Permitted	0.95	1.00	1.00		0.95	1.00
Satd. Flow (perm)	3433	1863	3364		1770	1583
Peak-hour factor, PHF	0.94	0.94	0.87	0.87	0.95	0.95
Adj. Flow (vph)	654	436	368	162	179	517
RTOR Reduction (vph)	0	0	75	0	0	175
Lane Group Flow (vph)	654	436	455	0	179	342
Confl. Peds. (#/hr)	2			2		
Turn Type	Prot	NA	NA		Perm	pm+ov
Protected Phases	5	2	6			5
Permitted Phases					4	4 5
Actuated Green, G (s)	17.4	35.1	13.7		11.0	28.4
Effective Green, g (s)	17.4	35.1	13.7		11.0	28.4
Actuated g/C Ratio	0.32	0.65	0.25		0.20	0.52
Clearance Time (s)	4.0	4.0	4.0		4.0	4.0
Vehicle Extension (s)	3.0	3.0	3.0		3.0	3.0
Lane Grp Cap (vph)	1104	1208	851		359	948
v/s Ratio Prot	c0.19	0.23	c0.14			0.12
v/s Ratio Perm					c0.10	0.10
v/c Ratio	0.59	0.36	0.54		0.50	0.36
Uniform Delay, d1	15.4	4.4	17.4		19.1	7.5
Progression Factor	1.00	1.00	1.00		1.00	1.00
Incremental Delay, d2	0.9	0.2	0.7		1.1	0.2
Delay (s)	16.2	4.5	18.1		20.2	7.8
Level of Service	B	A	B		C	A
Approach Delay (s)		11.6	18.1		11.0	
Approach LOS		B	B		B	
<b>Intersection Summary</b>						
HCM 2000 Control Delay			12.9		HCM 2000 Level of Service	B
HCM 2000 Volume to Capacity ratio			0.55			
Actuated Cycle Length (s)			54.1		Sum of lost time (s)	12.0
Intersection Capacity Utilization			51.7%		ICU Level of Service	A
Analysis Period (min)			15			
c Critical Lane Group						

HCM 6th Signalized Intersection Summary  
 3: US 101 NB Off-Ramp & Shiloh Road

Existing Project Alter. C Conditions  
 Timing Plan: P.M. Peak



Movement	EBT	EBR	WBL	WBT	NBL	NBR
Lane Configurations	↑↑			↑	↘	↗↗
Traffic Volume (veh/h)	379	0	0	562	526	651
Future Volume (veh/h)	379	0	0	562	526	651
Initial Q (Qb), veh	0	0	0	0	0	0
Ped-Bike Adj(A_pbT)		1.00	1.00		1.00	1.00
Parking Bus, Adj	1.00	1.00	1.00	1.00	1.00	1.00
Work Zone On Approach	No			No	No	
Adj Sat Flow, veh/h/ln	1870	0	0	1870	1870	1870
Adj Flow Rate, veh/h	403	0	0	579	584	723
Peak Hour Factor	0.94	0.94	0.97	0.97	0.90	0.90
Percent Heavy Veh, %	2	0	0	2	2	2
Cap, veh/h	1392	0	0	733	770	1205
Arrive On Green	0.39	0.00	0.00	0.39	0.43	0.43
Sat Flow, veh/h	3741	0	0	1870	1781	2790
Grp Volume(v), veh/h	403	0	0	579	584	723
Grp Sat Flow(s),veh/h/ln	1777	0	0	1870	1781	1395
Q Serve(g_s), s	3.5	0.0	0.0	12.4	12.6	9.0
Cycle Q Clear(g_c), s	3.5	0.0	0.0	12.4	12.6	9.0
Prop In Lane		0.00	0.00		1.00	1.00
Lane Grp Cap(c), veh/h	1392	0	0	733	770	1205
V/C Ratio(X)	0.29	0.00	0.00	0.79	0.76	0.60
Avail Cap(c_a), veh/h	2584	0	0	1360	1217	1905
HCM Platoon Ratio	1.00	1.00	1.00	1.00	1.00	1.00
Upstream Filter(I)	1.00	0.00	0.00	1.00	1.00	1.00
Uniform Delay (d), s/veh	9.5	0.0	0.0	12.2	10.9	9.9
Incr Delay (d2), s/veh	0.1	0.0	0.0	2.0	1.6	0.5
Initial Q Delay(d3),s/veh	0.0	0.0	0.0	0.0	0.0	0.0
%ile BackOfQ(50%),veh/ln	1.0	0.0	0.0	4.0	4.0	2.2
Unsig. Movement Delay, s/veh						
LnGrp Delay(d),s/veh	9.6	0.0	0.0	14.1	12.5	10.4
LnGrp LOS	A	A	A	B	B	B
Approach Vol, veh/h	403			579	1307	
Approach Delay, s/veh	9.6			14.1	11.3	
Approach LOS	A			B	B	
Timer - Assigned Phs		2			6	8
Phs Duration (G+Y+Rc), s		21.8			21.8	23.6
Change Period (Y+Rc), s		4.0			4.0	4.0
Max Green Setting (Gmax), s		33.0			33.0	31.0
Max Q Clear Time (g_c+I1), s		5.5			14.4	14.6
Green Ext Time (p_c), s		2.6			3.4	5.0
<b>Intersection Summary</b>						
HCM 6th Ctrl Delay			11.7			
HCM 6th LOS			B			

HCM Signalized Intersection Capacity Analysis  
4: Shiloh Road & US 101 SB Off-Ramp

Existing Project Alter. C Conditions  
Timing Plan: P.M. Peak



Movement	EBL	EBT	WBT	WBR	SBL	SBR
Lane Configurations		↑	↑		↘	↗
Traffic Volume (vph)	0	428	620	0	147	110
Future Volume (vph)	0	428	620	0	147	110
Ideal Flow (vphpl)	1900	1900	1900	1900	1900	1900
Total Lost time (s)		4.0	4.0		4.0	4.0
Lane Util. Factor		1.00	1.00		1.00	1.00
Frbp, ped/bikes		1.00	1.00		1.00	0.98
Flpb, ped/bikes		1.00	1.00		1.00	1.00
Frt		1.00	1.00		1.00	0.85
Flt Protected		1.00	1.00		0.95	1.00
Satd. Flow (prot)		1863	1863		1770	1548
Flt Permitted		1.00	1.00		0.95	1.00
Satd. Flow (perm)		1863	1863		1770	1548
Peak-hour factor, PHF	0.89	0.89	0.96	0.96	0.93	0.93
Adj. Flow (vph)	0	481	646	0	158	118
RTOR Reduction (vph)	0	0	0	0	0	96
Lane Group Flow (vph)	0	481	646	0	158	22
Confl. Peds. (#/hr)						1
Turn Type		NA	NA		Perm	Perm
Protected Phases		2	6			
Permitted Phases					4	4
Actuated Green, G (s)		20.5	20.5		6.7	6.7
Effective Green, g (s)		20.5	20.5		6.7	6.7
Actuated g/C Ratio		0.58	0.58		0.19	0.19
Clearance Time (s)		4.0	4.0		4.0	4.0
Vehicle Extension (s)		3.0	3.0		3.0	3.0
Lane Grp Cap (vph)		1084	1084		336	294
v/s Ratio Prot		0.26	c0.35			
v/s Ratio Perm					c0.09	0.01
v/c Ratio		0.44	0.60		0.47	0.08
Uniform Delay, d1		4.1	4.7		12.7	11.7
Progression Factor		1.00	1.00		1.00	1.00
Incremental Delay, d2		0.3	0.9		1.0	0.1
Delay (s)		4.4	5.6		13.7	11.8
Level of Service		A	A		B	B
Approach Delay (s)		4.4	5.6		12.9	
Approach LOS		A	A		B	
<b>Intersection Summary</b>						
HCM 2000 Control Delay			6.6		HCM 2000 Level of Service	A
HCM 2000 Volume to Capacity ratio			0.56			
Actuated Cycle Length (s)			35.2		Sum of lost time (s)	8.0
Intersection Capacity Utilization			61.0%		ICU Level of Service	B
Analysis Period (min)			15			
c Critical Lane Group						

Intersection						
Int Delay, s/veh	2.5					
Movement	EBT	EBR	WBL	WBT	NBL	NBR
Lane Configurations	↑↑		↘	↑	↘	↘
Traffic Vol, veh/h	856	28	79	656	15	149
Future Vol, veh/h	856	28	79	656	15	149
Conflicting Peds, #/hr	0	0	0	0	0	0
Sign Control	Free	Free	Free	Free	Stop	Stop
RT Channelized	-	None	-	None	-	None
Storage Length	-	-	68	-	0	0
Veh in Median Storage, #	0	-	-	0	0	-
Grade, %	0	-	-	0	0	-
Peak Hour Factor	89	89	92	92	89	89
Heavy Vehicles, %	2	2	2	2	2	2
Mvmt Flow	962	31	86	713	17	167



















Major/Minor	Major1	Major2	Minor1		
Conflicting Flow All	0	0	993	0	1863 497
Stage 1	-	-	-	-	978 -
Stage 2	-	-	-	-	885 -
Critical Hdwy	-	-	4.13	-	6.63 6.93
Critical Hdwy Stg 1	-	-	-	-	5.83 -
Critical Hdwy Stg 2	-	-	-	-	5.43 -
Follow-up Hdwy	-	-	2.219	-	3.519 3.319
Pot Cap-1 Maneuver	-	-	694	-	72 519
Stage 1	-	-	-	-	326 -
Stage 2	-	-	-	-	402 -
Platoon blocked, %	-	-	-	-	-
Mov Cap-1 Maneuver	-	-	694	-	63 519
Mov Cap-2 Maneuver	-	-	-	-	63 -
Stage 1	-	-	-	-	326 -
Stage 2	-	-	-	-	352 -

Approach	EB	WB	NB
HCM Control Delay, s	0	1.2	21.3
HCM LOS			C

Minor Lane/Major Mvmt	NBLn1	NBLn2	EBT	EBR	WBL	WBT
Capacity (veh/h)	63	519	-	-	694	-
HCM Lane V/C Ratio	0.268	0.323	-	-	0.124	-
HCM Control Delay (s)	81.8	15.2	-	-	10.9	-
HCM Lane LOS	F	C	-	-	B	-
HCM 95th %tile Q(veh)	0.9	1.4	-	-	0.4	-

HCM Signalized Intersection Capacity Analysis  
6: Conde Lane & Shiloh Road

Existing Project Alter. C Conditions  
Timing Plan: P.M. Peak

												
Movement	EBL	EBT	EBR	WBL	WBT	WBR	NBL	NBT	NBR	SBL	SBT	SBR
Lane Configurations												
Traffic Volume (vph)	69	475	2	7	461	289	5	3	17	297	0	39
Future Volume (vph)	69	475	2	7	461	289	5	3	17	297	0	39
Ideal Flow (vphpl)	1900	1900	1900	1900	1900	1900	1900	1900	1900	1900	1900	1900
Total Lost time (s)	4.0	4.0		4.0	4.0			4.0			4.0	4.0
Lane Util. Factor	1.00	0.95		1.00	0.95			1.00			1.00	1.00
Frbp, ped/bikes	1.00	1.00		1.00	0.99			1.00			1.00	1.00
Flpb, ped/bikes	1.00	1.00		1.00	1.00			1.00			1.00	1.00
Frt	1.00	1.00		1.00	0.94			0.91			1.00	0.85
Flt Protected	0.95	1.00		0.95	1.00			0.99			0.95	1.00
Satd. Flow (prot)	1770	3537		1770	3307			1676			1770	1583
Flt Permitted	0.95	1.00		0.95	1.00			0.99			0.95	1.00
Satd. Flow (perm)	1770	3537		1770	3307			1676			1770	1583
Peak-hour factor, PHF	0.88	0.88	0.88	0.80	0.80	0.80	0.63	0.63	0.63	0.88	0.88	0.88
Adj. Flow (vph)	78	540	2	9	576	361	8	5	27	338	0	44
RTOR Reduction (vph)	0	0	0	0	88	0	0	25	0	0	0	0
Lane Group Flow (vph)	78	542	0	9	849	0	0	15	0	0	338	44
Confl. Peds. (#/hr)	1					1						
Turn Type	Prot	NA		Prot	NA		Split	NA		Split	NA	custom
Protected Phases	5	2		1	6		7	7		4	4	
Permitted Phases												6
Actuated Green, G (s)	6.4	30.4		1.2	25.2			4.9			12.6	25.2
Effective Green, g (s)	6.4	30.4		1.2	25.2			4.9			12.6	25.2
Actuated g/C Ratio	0.10	0.47		0.02	0.39			0.08			0.19	0.39
Clearance Time (s)	4.0	4.0		4.0	4.0			4.0			4.0	4.0
Vehicle Extension (s)	3.0	3.0		3.0	3.0			3.0			3.0	3.0
Lane Grp Cap (vph)	174	1651		32	1280			126			342	612
v/s Ratio Prot	c0.04	0.15		0.01	c0.26			c0.01			c0.19	
v/s Ratio Perm												0.03
v/c Ratio	0.45	0.33		0.28	0.66			0.12			0.99	0.07
Uniform Delay, d1	27.7	10.9		31.5	16.5			28.1			26.2	12.6
Progression Factor	1.00	1.00		1.00	1.00			1.00			1.00	1.00
Incremental Delay, d2	1.8	0.1		4.8	1.3			0.4			45.0	0.1
Delay (s)	29.5	11.0		36.3	17.8			28.5			71.2	12.6
Level of Service	C	B		D	B			C			E	B
Approach Delay (s)		13.4			17.9			28.5			64.5	
Approach LOS		B			B			C			E	
<b>Intersection Summary</b>												
HCM 2000 Control Delay			25.7									HCM 2000 Level of Service C
HCM 2000 Volume to Capacity ratio			0.66									
Actuated Cycle Length (s)			65.1							16.0		
Intersection Capacity Utilization			61.8%									ICU Level of Service B
Analysis Period (min)			15									
c Critical Lane Group												

HCM 6th TWSC  
7: Entrance 1/Gridley Drive & Shiloh Road

Existing Project Alter. C Conditions  
Timing Plan: P.M. Peak

Intersection												
Int Delay, s/veh	2.7											
Movement	EBL	EBT	EBR	WBL	WBT	WBR	NBL	NBT	NBR	SBL	SBT	SBR
Lane Configurations		↕			↕		↕	↕			↕	
Traffic Vol, veh/h	17	103	70	5	125	0	66	0	5	0	0	14
Future Vol, veh/h	17	103	70	5	125	0	66	0	5	0	0	14
Conflicting Peds, #/hr	1	0	0	0	0	0	0	0	0	0	0	0
Sign Control	Free	Free	Free	Free	Free	Free	Stop	Stop	Stop	Stop	Stop	Stop
RT Channelized	-	-	None	-	-	None	-	-	None	-	-	None
Storage Length	-	-	-	-	-	-	0	-	-	-	-	-
Veh in Median Storage, #	-	0	-	-	0	-	-	0	-	-	0	-
Grade, %	-	0	-	-	0	-	-	0	-	-	0	-
Peak Hour Factor	94	94	94	69	69	69	100	100	100	58	58	58
Heavy Vehicles, %	2	2	2	2	2	2	2	2	2	2	2	2
Mvmt Flow	18	110	74	7	181	0	66	0	5	0	0	24

Major/Minor	Major1			Major2			Minor1			Minor2		
Conflicting Flow All	182	0	0	184	0	0	390	379	147	382	416	182
Stage 1	-	-	-	-	-	-	183	183	-	196	196	-
Stage 2	-	-	-	-	-	-	207	196	-	186	220	-
Critical Hdwy	4.12	-	-	4.12	-	-	7.12	6.52	6.22	7.12	6.52	6.22
Critical Hdwy Stg 1	-	-	-	-	-	-	6.12	5.52	-	6.12	5.52	-
Critical Hdwy Stg 2	-	-	-	-	-	-	6.12	5.52	-	6.12	5.52	-
Follow-up Hdwy	2.218	-	-	2.218	-	-	3.518	4.018	3.318	3.518	4.018	3.318
Pot Cap-1 Maneuver	1393	-	-	1391	-	-	569	553	900	576	527	861
Stage 1	-	-	-	-	-	-	819	748	-	806	739	-
Stage 2	-	-	-	-	-	-	795	739	-	816	721	-
Platoon blocked, %		-	-		-	-						
Mov Cap-1 Maneuver	1392	-	-	1391	-	-	544	541	900	563	515	860
Mov Cap-2 Maneuver	-	-	-	-	-	-	544	541	-	563	515	-
Stage 1	-	-	-	-	-	-	807	737	-	793	734	-
Stage 2	-	-	-	-	-	-	768	734	-	799	710	-

Approach	EB			WB			NB			SB		
HCM Control Delay, s	0.7			0.3			12.3			9.3		
HCM LOS							B			A		

Minor Lane/Major Mvmt	NBLn1	NBLn2	EBL	EBT	EBR	WBL	WBT	WBR	SBLn1
Capacity (veh/h)	544	900	1392	-	-	1391	-	-	860
HCM Lane V/C Ratio	0.121	0.006	0.013	-	-	0.005	-	-	0.028
HCM Control Delay (s)	12.5	9	7.6	0	-	7.6	0	-	9.3
HCM Lane LOS	B	A	A	A	-	A	A	-	A
HCM 95th %tile Q(veh)	0.4	0	0	-	-	0	-	-	0.1

HCM 6th TWSC  
8: Old Redwood Hwy & Entrance 1

Existing Project Alter. C Conditions  
Timing Plan: P.M. Peak

Intersection												
Int Delay, s/veh	0.7											
Movement	EBL	EBT	EBR	WBL	WBT	WBR	NBL	NBT	NBR	SBL	SBT	SBR
Lane Configurations		↕		↕	↕			↕		↕	↕	
Traffic Vol, veh/h	3	0	0	9	0	15	0	505	10	16	427	0
Future Vol, veh/h	3	0	0	9	0	15	0	505	10	16	427	0
Conflicting Peds, #/hr	0	0	0	0	0	0	0	0	0	0	0	0
Sign Control	Stop	Stop	Stop	Stop	Stop	Stop	Free	Free	Free	Free	Free	Free
RT Channelized	-	-	None	-	-	None	-	-	None	-	-	None
Storage Length	-	-	-	0	-	-	-	-	-	50	-	-
Veh in Median Storage, #	-	0	-	-	0	-	-	0	-	-	0	-
Grade, %	-	0	-	-	0	-	-	0	-	-	0	-
Peak Hour Factor	38	38	38	100	100	100	91	91	91	94	94	94
Heavy Vehicles, %	2	2	2	2	2	2	2	2	2	2	2	2
Mvmt Flow	8	0	0	9	0	15	0	555	11	17	454	0

Major/Minor	Minor2		Minor1		Major1		Major2					
Conflicting Flow All	1056	1054	454	1049	1049	561	454	0	0	566	0	0
Stage 1	488	488	-	561	561	-	-	-	-	-	-	-
Stage 2	568	566	-	488	488	-	-	-	-	-	-	-
Critical Hdwy	7.12	6.52	6.22	7.12	6.52	6.22	4.12	-	-	4.12	-	-
Critical Hdwy Stg 1	6.12	5.52	-	6.12	5.52	-	-	-	-	-	-	-
Critical Hdwy Stg 2	6.12	5.52	-	6.12	5.52	-	-	-	-	-	-	-
Follow-up Hdwy	3.518	4.018	3.318	3.518	4.018	3.318	2.218	-	-	2.218	-	-
Pot Cap-1 Maneuver	203	226	606	205	227	527	1107	-	-	1006	-	-
Stage 1	561	550	-	512	510	-	-	-	-	-	-	-
Stage 2	508	507	-	561	550	-	-	-	-	-	-	-
Platoon blocked, %								-	-	-	-	-
Mov Cap-1 Maneuver	195	222	606	202	223	527	1107	-	-	1006	-	-
Mov Cap-2 Maneuver	195	222	-	202	223	-	-	-	-	-	-	-
Stage 1	561	541	-	512	510	-	-	-	-	-	-	-
Stage 2	494	507	-	552	541	-	-	-	-	-	-	-

Approach	EB		WB		NB		SB	
HCM Control Delay, s	24.2		16.4		0		0.3	
HCM LOS	C		C					

Minor Lane/Major Mvmt	NBL	NBT	NBR	EBLn1	WBLn1	WBLn2	SBL	SBT	SBR
Capacity (veh/h)	1107	-	-	195	202	527	1006	-	-
HCM Lane V/C Ratio	-	-	-	0.04	0.045	0.028	0.017	-	-
HCM Control Delay (s)	0	-	-	24.2	23.7	12	8.6	-	-
HCM Lane LOS	A	-	-	C	C	B	A	-	-
HCM 95th %tile Q(veh)	0	-	-	0.1	0.1	0.1	0.1	-	-



Intersection						
Int Delay, s/veh	0					
Movement	EBT	EBR	WBL	WBT	NBL	NBR
Lane Configurations	↔			↔	↔	↔
Traffic Vol, veh/h	86	0	0	116	0	0
Future Vol, veh/h	86	0	0	116	0	0
Conflicting Peds, #/hr	0	0	0	0	0	0
Sign Control	Free	Free	Free	Free	Stop	Stop
RT Channelized	-	None	-	None	-	None
Storage Length	-	-	-	-	0	0
Veh in Median Storage, #	0	-	-	0	0	-
Grade, %	0	-	-	0	0	-
Peak Hour Factor	92	92	68	68	100	100
Heavy Vehicles, %	2	2	2	2	2	2
Mvmt Flow	93	0	0	171	0	0

Major/Minor	Major1	Major2	Minor1		
Conflicting Flow All	0	0	93	0	264 93
Stage 1	-	-	-	-	93 -
Stage 2	-	-	-	-	171 -
Critical Hdwy	-	-	4.12	-	6.42 6.22
Critical Hdwy Stg 1	-	-	-	-	5.42 -
Critical Hdwy Stg 2	-	-	-	-	5.42 -
Follow-up Hdwy	-	-	2.218	-	3.518 3.318
Pot Cap-1 Maneuver	-	-	1501	-	725 964
Stage 1	-	-	-	-	931 -
Stage 2	-	-	-	-	859 -
Platoon blocked, %	-	-	-	-	-
Mov Cap-1 Maneuver	-	-	1501	-	725 964
Mov Cap-2 Maneuver	-	-	-	-	725 -
Stage 1	-	-	-	-	931 -
Stage 2	-	-	-	-	859 -

Approach	EB	WB	NB
HCM Control Delay, s	0	0	0
HCM LOS			A

Minor Lane/Major Mvmt	NBLn1	NBLn2	EBT	EBR	WBL	WBT
Capacity (veh/h)	-	-	-	-	1501	-
HCM Lane V/C Ratio	-	-	-	-	-	-
HCM Control Delay (s)	0	0	-	-	0	-
HCM Lane LOS	A	A	-	-	A	-
HCM 95th %tile Q(veh)	-	-	-	-	0	-

HCM 6th Signalized Intersection Summary

Existing Project Alter. C Conditions

10: US 101 NB Off Ramp/Lakewood Drive & Old Redwood Highway

Timing Plan: P.M. Peak



Movement	EBL	EBT	EBR	WBL	WBT	WBR	NBL	NBT	NBR	SBL	SBT	SBR
Lane Configurations	↔↔	↑			↑↑		↔	↔↔		↔↔		↔
Traffic Volume (veh/h)	261	360	0	0	506	192	500	412	251	249	0	577
Future Volume (veh/h)	261	360	0	0	506	192	500	412	251	249	0	577
Initial Q (Qb), veh	0	0	0	0	0	0	0	0	0	0	0	0
Ped-Bike Adj(A_pbT)	1.00		1.00	1.00		0.98	1.00		0.99	1.00		1.00
Parking Bus, Adj	1.00	1.00	1.00	1.00	1.00	1.00	1.00	1.00	1.00	1.00	1.00	1.00
Work Zone On Approach		No			No			No			No	
Adj Sat Flow, veh/h/ln	1870	1870	0	0	1870	1870	1870	1870	1870	1870	0	1870
Adj Flow Rate, veh/h	300	414	0	0	556	211	421	618	273	259	0	0
Peak Hour Factor	0.87	0.87	0.87	0.91	0.91	0.91	0.92	0.92	0.92	0.96	0.96	0.96
Percent Heavy Veh, %	2	2	0	0	2	2	2	2	2	2	0	2
Cap, veh/h	388	1010	0	0	938	355	584	805	355	0	0	0
Arrive On Green	0.11	0.54	0.00	0.00	0.37	0.37	0.33	0.33	0.33	0.00	0.00	0.00
Sat Flow, veh/h	3456	1870	0	0	2600	948	1781	2453	1083		0	
Grp Volume(v), veh/h	300	414	0	0	394	373	421	471	420		0.0	
Grp Sat Flow(s),veh/h/ln	1728	1870	0	0	1777	1677	1781	1870	1666			
Q Serve(g_s), s	6.3	9.7	0.0	0.0	13.3	13.3	15.5	16.8	16.9			
Cycle Q Clear(g_c), s	6.3	9.7	0.0	0.0	13.3	13.3	15.5	16.8	16.9			
Prop In Lane	1.00		0.00	0.00		0.57	1.00		0.65			
Lane Grp Cap(c), veh/h	388	1010	0	0	665	628	584	614	547			
V/C Ratio(X)	0.77	0.41	0.00	0.00	0.59	0.59	0.72	0.77	0.77			
Avail Cap(c_a), veh/h	418	1010	0	0	665	628	694	729	649			
HCM Platoon Ratio	1.00	1.00	1.00	1.00	1.00	1.00	1.00	1.00	1.00			
Upstream Filter(I)	1.00	1.00	0.00	0.00	1.00	1.00	1.00	1.00	1.00			
Uniform Delay (d), s/veh	32.1	10.1	0.0	0.0	18.7	18.7	22.0	22.5	22.5			
Incr Delay (d2), s/veh	8.2	1.2	0.0	0.0	3.8	4.1	3.0	4.2	4.7			
Initial Q Delay(d3),s/veh	0.0	0.0	0.0	0.0	0.0	0.0	0.0	0.0	0.0			
%ile BackOfQ(50%),veh/ln	2.9	3.7	0.0	0.0	5.7	5.4	6.5	7.6	6.9			
Unsig. Movement Delay, s/veh												
LnGrp Delay(d),s/veh	40.3	11.3	0.0	0.0	22.6	22.9	25.0	26.6	27.1			
LnGrp LOS	D	B	A	A	C	C	C	C	C			
Approach Vol, veh/h		714			767			1312				
Approach Delay, s/veh		23.5			22.7			26.2				
Approach LOS		C			C			C				
Timer - Assigned Phs		2			5	6		8				
Phs Duration (G+Y+Rc), s		45.3			12.3	33.0		29.1				
Change Period (Y+Rc), s		5.1			4.0	5.1		4.7				
Max Green Setting (Gmax), s		40.2			9.0	27.2		29.0				
Max Q Clear Time (g_c+I1), s		11.7			8.3	15.3		18.9				
Green Ext Time (p_c), s		2.6			0.1	3.8		5.2				

Intersection Summary

HCM 6th Ctrl Delay	24.6
HCM 6th LOS	C

Notes

User approved volume balancing among the lanes for turning movement.  
 Unsignalized Delay for [SBR] is excluded from calculations of the approach delay and intersection delay.

HCM 6th Signalized Intersection Summary

Existing Project Alter. C Conditions

12: US 101 SB On Ramp/US 101 SB Off Ramp & Old Redwood Highway

Timing Plan: P.M. Peak



Movement	EBL	EBT	EBR	WBL	WBT	WBR	NBL	NBT	NBR	SBL	SBT	SBR
Lane Configurations		↑↑	↗	↘	↑↑					↘	↔	
Traffic Volume (veh/h)	0	535	381	381	1024	0	0	0	0	177	0	129
Future Volume (veh/h)	0	535	381	381	1024	0	0	0	0	177	0	129
Initial Q (Qb), veh	0	0	0	0	0	0				0	0	0
Ped-Bike Adj(A_pbT)	1.00		0.98	1.00		1.00				1.00		1.00
Parking Bus, Adj	1.00	1.00	1.00	1.00	1.00	1.00				1.00	1.00	1.00
Work Zone On Approach		No			No						No	
Adj Sat Flow, veh/h/ln	0	1870	1870	1870	1870	0				1870	1870	1870
Adj Flow Rate, veh/h	0	569	405	428	1151	0				184	41	0
Peak Hour Factor	0.94	0.94	0.94	0.89	0.89	0.89				0.83	0.83	0.83
Percent Heavy Veh, %	0	2	2	2	2	0				2	2	2
Cap, veh/h	0	1425	626	461	2549	0				253	265	
Arrive On Green	0.00	0.40	0.40	0.26	0.72	0.00				0.14	0.14	0.00
Sat Flow, veh/h	0	3647	1560	1781	3647	0				1781	1870	0
Grp Volume(v), veh/h	0	569	405	428	1151	0				184	41	0
Grp Sat Flow(s),veh/h/ln	0	1777	1560	1781	1777	0				1781	1870	0
Q Serve(g_s), s	0.0	7.9	14.6	16.3	9.4	0.0				6.9	1.3	0.0
Cycle Q Clear(g_c), s	0.0	7.9	14.6	16.3	9.4	0.0				6.9	1.3	0.0
Prop In Lane	0.00		1.00	1.00		0.00				1.00		0.00
Lane Grp Cap(c), veh/h	0	1425	626	461	2549	0				253	265	
V/C Ratio(X)	0.00	0.40	0.65	0.93	0.45	0.00				0.73	0.15	
Avail Cap(c_a), veh/h	0	1425	626	461	2549	0				264	277	
HCM Platoon Ratio	1.00	1.00	1.00	1.00	1.00	1.00				1.00	1.00	1.00
Upstream Filter(I)	0.00	1.00	1.00	1.00	1.00	0.00				1.00	1.00	0.00
Uniform Delay (d), s/veh	0.0	14.9	16.9	25.2	4.1	0.0				28.6	26.2	0.0
Incr Delay (d2), s/veh	0.0	0.8	5.1	25.3	0.6	0.0				9.3	0.3	0.0
Initial Q Delay(d3),s/veh	0.0	0.0	0.0	0.0	0.0	0.0				0.0	0.0	0.0
%ile BackOfQ(50%),veh/ln	0.0	3.0	5.5	9.5	2.2	0.0				3.5	0.6	0.0
Unsig. Movement Delay, s/veh												
LnGrp Delay(d),s/veh	0.0	15.7	22.0	50.4	4.7	0.0				37.9	26.5	0.0
LnGrp LOS	A	B	C	D	A	A				D	C	
Approach Vol, veh/h		974			1579						225	
Approach Delay, s/veh		18.3			17.1						35.8	
Approach LOS		B			B						D	
Timer - Assigned Phs		2			5	6		8				
Phs Duration (G+Y+Rc), s		55.0			22.0	33.0		14.6				
Change Period (Y+Rc), s		5.1			4.0	5.1		4.7				
Max Green Setting (Gmax), s		49.9			18.0	27.9		10.3				
Max Q Clear Time (g_c+I1), s		11.4			18.3	16.6		8.9				
Green Ext Time (p_c), s		10.5			0.0	4.1		0.1				

Intersection Summary























HCM 6th Ctrl Delay	19.0
HCM 6th LOS	B

Notes

- User approved volume balancing among the lanes for turning movement.
- User approved ignoring U-Turning movement.
- Unsignalized Delay for [SBR] is excluded from calculations of the approach delay and intersection delay.

HCM 6th Signalized Intersection Summary  
 1: Old Redwood Hwy & Shiloh Road

Existing Project Alter. C Conditions  
 Timing Plan: Saturday Midday Peak

												
Movement	EBL	EBT	EBR	WBL	WBT	WBR	NBL	NBT	NBR	SBL	SBT	SBR
Lane Configurations												
Traffic Volume (veh/h)	123	175	170	21	188	30	177	233	24	34	187	180
Future Volume (veh/h)	123	175	170	21	188	30	177	233	24	34	187	180
Initial Q (Qb), veh	0	0	0	0	0	0	0	0	0	0	0	0
Ped-Bike Adj(A_pbT)	1.00		0.97	1.00		1.00	1.00		0.98	1.00		0.97
Parking Bus, Adj	1.00	1.00	1.00	1.00	1.00	1.00	1.00	1.00	1.00	1.00	1.00	1.00
Work Zone On Approach		No			No			No			No	
Adj Sat Flow, veh/h/ln	1870	1870	1870	1870	1870	1870	1870	1870	1870	1870	1870	1870
Adj Flow Rate, veh/h	138	197	191	24	219	35	190	251	26	37	205	198
Peak Hour Factor	0.89	0.89	0.89	0.86	0.86	0.86	0.93	0.93	0.93	0.91	0.91	0.91
Percent Heavy Veh, %	2	2	2	2	2	2	2	2	2	2	2	2
Cap, veh/h	348	366	300	33	303	286	252	450	373	155	348	286
Arrive On Green	0.20	0.20	0.20	0.18	0.18	0.18	0.14	0.24	0.24	0.09	0.19	0.19
Sat Flow, veh/h	1781	1870	1534	184	1677	1585	1781	1870	1551	1781	1870	1538
Grp Volume(v), veh/h	138	197	191	243	0	35	190	251	26	37	205	198
Grp Sat Flow(s),veh/h/ln	1781	1870	1534	1861	0	1585	1781	1870	1551	1781	1870	1538
Q Serve(g_s), s	3.9	5.4	6.6	7.1	0.0	1.1	5.9	6.8	0.7	1.1	5.8	6.9
Cycle Q Clear(g_c), s	3.9	5.4	6.6	7.1	0.0	1.1	5.9	6.8	0.7	1.1	5.8	6.9
Prop In Lane	1.00		1.00	0.10		1.00	1.00		1.00	1.00		1.00
Lane Grp Cap(c), veh/h	348	366	300	336	0	286	252	450	373	155	348	286
V/C Ratio(X)	0.40	0.54	0.64	0.72	0.00	0.12	0.75	0.56	0.07	0.24	0.59	0.69
Avail Cap(c_a), veh/h	946	993	815	1232	0	1049	450	1417	1175	186	1140	937
HCM Platoon Ratio	1.00	1.00	1.00	1.00	1.00	1.00	1.00	1.00	1.00	1.00	1.00	1.00
Upstream Filter(I)	1.00	1.00	1.00	1.00	0.00	1.00	1.00	1.00	1.00	1.00	1.00	1.00
Uniform Delay (d), s/veh	20.1	20.8	21.2	22.2	0.0	19.7	23.7	19.1	16.8	24.4	21.4	21.8
Incr Delay (d2), s/veh	0.7	1.2	2.2	2.9	0.0	0.2	4.5	1.1	0.1	0.8	1.6	3.0
Initial Q Delay(d3),s/veh	0.0	0.0	0.0	0.0	0.0	0.0	0.0	0.0	0.0	0.0	0.0	0.0
%ile BackOfQ(50%),veh/ln	1.5	2.2	2.2	3.0	0.0	0.4	2.5	2.6	0.2	0.5	2.4	2.4
Unsig. Movement Delay, s/veh												
LnGrp Delay(d),s/veh	20.9	22.0	23.5	25.1	0.0	19.9	28.2	20.2	16.9	25.2	23.0	24.8
LnGrp LOS	C	C	C	C	A	B	C	C	B	C	C	C
Approach Vol, veh/h		526			278			467			440	
Approach Delay, s/veh		22.2			24.5			23.3			24.0	
Approach LOS		C			C			C			C	
Timer - Assigned Phs		2	3	4		6	7	8				
Phs Duration (G+Y+Rc), s		15.7	11.6	15.2		14.9	8.5	18.3				
Change Period (Y+Rc), s		4.5	3.5	4.5		4.5	3.5	4.5				
Max Green Setting (Gmax), s		30.5	14.5	35.0		38.0	6.0	43.5				
Max Q Clear Time (g_c+I1), s		8.6	7.9	8.9		9.1	3.1	8.8				
Green Ext Time (p_c), s		2.0	0.3	1.8		1.4	0.0	1.4				
<b>Intersection Summary</b>												
HCM 6th Ctrl Delay				23.3								
HCM 6th LOS				C								

# HCM Signalized Intersection Capacity Analysis

## 2: Shiloh Road & Hembree Ln

Existing Project Alter. C Conditions  
Timing Plan: Saturday Midday Peak



Movement	EBL	EBT	WBT	WBR	SBL	SBR
Lane Configurations	↔↔	↑	↕↔		↔	↔
Traffic Volume (vph)	622	380	346	159	160	580
Future Volume (vph)	622	380	346	159	160	580
Ideal Flow (vphpl)	1900	1900	1900	1900	1900	1900
Total Lost time (s)	4.0	4.0	4.0		4.0	4.0
Lane Util. Factor	0.97	1.00	0.95		1.00	1.00
Frpb, ped/bikes	1.00	1.00	1.00		1.00	1.00
Flpb, ped/bikes	1.00	1.00	1.00		1.00	1.00
Frt	1.00	1.00	0.95		1.00	0.85
Flt Protected	0.95	1.00	1.00		0.95	1.00
Satd. Flow (prot)	3433	1863	3358		1770	1583
Flt Permitted	0.95	1.00	1.00		0.95	1.00
Satd. Flow (perm)	3433	1863	3358		1770	1583
Peak-hour factor, PHF	0.94	0.94	0.96	0.96	0.91	0.91
Adj. Flow (vph)	662	404	360	166	176	637
RTOR Reduction (vph)	0	0	81	0	0	178
Lane Group Flow (vph)	662	404	445	0	176	459
Confl. Peds. (#/hr)	1			1		
Turn Type	Prot	NA	NA		Perm	pm+ov
Protected Phases	5	2	6			5
Permitted Phases					4	4 5
Actuated Green, G (s)	18.0	35.4	13.4		10.9	28.9
Effective Green, g (s)	18.0	35.4	13.4		10.9	28.9
Actuated g/C Ratio	0.33	0.65	0.25		0.20	0.53
Clearance Time (s)	4.0	4.0	4.0		4.0	4.0
Vehicle Extension (s)	3.0	3.0	3.0		3.0	3.0
Lane Grp Cap (vph)	1138	1214	828		355	959
v/s Ratio Prot	c0.19	0.22	c0.13			c0.16
v/s Ratio Perm					0.10	0.13
v/c Ratio	0.58	0.33	0.54		0.50	0.48
Uniform Delay, d1	15.0	4.2	17.8		19.3	8.0
Progression Factor	1.00	1.00	1.00		1.00	1.00
Incremental Delay, d2	0.8	0.2	0.7		1.1	0.4
Delay (s)	15.8	4.4	18.4		20.4	8.3
Level of Service	B	A	B		C	A
Approach Delay (s)		11.5	18.4		10.9	
Approach LOS		B	B		B	
<b>Intersection Summary</b>						
HCM 2000 Control Delay			12.8		HCM 2000 Level of Service	B
HCM 2000 Volume to Capacity ratio			0.56			
Actuated Cycle Length (s)			54.3		Sum of lost time (s)	12.0
Intersection Capacity Utilization			57.9%		ICU Level of Service	B
Analysis Period (min)			15			
c Critical Lane Group						

HCM 6th Signalized Intersection Summary  
 3: US 101 NB Off-Ramp & Shiloh Road

Existing Project Alter. C Conditions  
 Timing Plan: Saturday Midday Peak



Movement	EBT	EBR	WBL	WBT	NBL	NBR
Lane Configurations	↑↑			↑	↘	↗↗
Traffic Volume (veh/h)	405	0	0	706	352	595
Future Volume (veh/h)	405	0	0	706	352	595
Initial Q (Qb), veh	0	0	0	0	0	0
Ped-Bike Adj(A_pbT)		1.00	1.00		1.00	1.00
Parking Bus, Adj	1.00	1.00	1.00	1.00	1.00	1.00
Work Zone On Approach	No			No	No	
Adj Sat Flow, veh/h/ln	1870	0	0	1870	1870	1870
Adj Flow Rate, veh/h	445	0	0	793	371	626
Peak Hour Factor	0.91	0.91	0.89	0.89	0.95	0.95
Percent Heavy Veh, %	2	0	0	2	2	2
Cap, veh/h	1797	0	0	946	575	900
Arrive On Green	0.51	0.00	0.00	0.51	0.32	0.32
Sat Flow, veh/h	3741	0	0	1870	1781	2790
Grp Volume(v), veh/h	445	0	0	793	371	626
Grp Sat Flow(s),veh/h/ln	1777	0	0	1870	1781	1395
Q Serve(g_s), s	3.3	0.0	0.0	16.9	8.3	9.1
Cycle Q Clear(g_c), s	3.3	0.0	0.0	16.9	8.3	9.1
Prop In Lane		0.00	0.00		1.00	1.00
Lane Grp Cap(c), veh/h	1797	0	0	946	575	900
V/C Ratio(X)	0.25	0.00	0.00	0.84	0.65	0.70
Avail Cap(c_a), veh/h	2519	0	0	1326	1186	1858
HCM Platoon Ratio	1.00	1.00	1.00	1.00	1.00	1.00
Upstream Filter(I)	1.00	0.00	0.00	1.00	1.00	1.00
Uniform Delay (d), s/veh	6.5	0.0	0.0	9.9	13.5	13.8
Incr Delay (d2), s/veh	0.1	0.0	0.0	3.5	1.2	1.0
Initial Q Delay(d3),s/veh	0.0	0.0	0.0	0.0	0.0	0.0
%ile BackOfQ(50%),veh/ln	0.8	0.0	0.0	5.1	2.9	2.5
Unsig. Movement Delay, s/veh						
LnGrp Delay(d),s/veh	6.6	0.0	0.0	13.4	14.7	14.8
LnGrp LOS	A	A	A	B	B	B
Approach Vol, veh/h	445			793	997	
Approach Delay, s/veh	6.6			13.4	14.7	
Approach LOS	A			B	B	
Timer - Assigned Phs		2			6	8
Phs Duration (G+Y+Rc), s		27.5			27.5	19.0
Change Period (Y+Rc), s		4.0			4.0	4.0
Max Green Setting (Gmax), s		33.0			33.0	31.0
Max Q Clear Time (g_c+I1), s		5.3			18.9	11.1
Green Ext Time (p_c), s		2.9			4.6	3.9
<b>Intersection Summary</b>						
HCM 6th Ctrl Delay			12.6			
HCM 6th LOS			B			

HCM Signalized Intersection Capacity Analysis  
4: Shiloh Road & US 101 SB Off-Ramp

Existing Project Alter. C Conditions  
Timing Plan: Saturday Midday Peak



Movement	EBL	EBT	WBT	WBR	SBL	SBR
Lane Configurations		↑	↑		↘	↘
Traffic Volume (vph)	0	273	525	0	211	151
Future Volume (vph)	0	273	525	0	211	151
Ideal Flow (vphpl)	1900	1900	1900	1900	1900	1900
Total Lost time (s)		4.0	4.0		4.0	4.0
Lane Util. Factor		1.00	1.00		1.00	1.00
Frbp, ped/bikes		1.00	1.00		1.00	1.00
Flpb, ped/bikes		1.00	1.00		1.00	1.00
Frt		1.00	1.00		1.00	0.85
Flt Protected		1.00	1.00		0.95	1.00
Satd. Flow (prot)		1863	1863		1770	1583
Flt Permitted		1.00	1.00		0.95	1.00
Satd. Flow (perm)		1863	1863		1770	1583
Peak-hour factor, PHF	0.96	0.96	0.96	0.96	0.68	0.68
Adj. Flow (vph)	0	284	547	0	310	222
RTOR Reduction (vph)	0	0	0	0	0	142
Lane Group Flow (vph)	0	284	547	0	310	80
Confl. Bikes (#/hr)				2		
Turn Type		NA	NA		Perm	Perm
Protected Phases		2	6			
Permitted Phases					4	4
Actuated Green, G (s)		17.8	17.8		14.4	14.4
Effective Green, g (s)		17.8	17.8		14.4	14.4
Actuated g/C Ratio		0.44	0.44		0.36	0.36
Clearance Time (s)		4.0	4.0		4.0	4.0
Vehicle Extension (s)		3.0	3.0		3.0	3.0
Lane Grp Cap (vph)		824	824		634	567
v/s Ratio Prot		0.15	c0.29			
v/s Ratio Perm					c0.18	0.05
v/c Ratio		0.34	0.66		0.49	0.14
Uniform Delay, d1		7.4	8.8		10.0	8.7
Progression Factor		1.00	1.00		1.00	1.00
Incremental Delay, d2		0.3	2.0		0.6	0.1
Delay (s)		7.6	10.9		10.6	8.8
Level of Service		A	B		B	A
Approach Delay (s)		7.6	10.9		9.9	
Approach LOS		A	B		A	
<b>Intersection Summary</b>						
HCM 2000 Control Delay			9.8		HCM 2000 Level of Service	A
HCM 2000 Volume to Capacity ratio			0.59			
Actuated Cycle Length (s)			40.2		Sum of lost time (s)	8.0
Intersection Capacity Utilization			95.8%		ICU Level of Service	F
Analysis Period (min)			15			
c Critical Lane Group						

Intersection						
Int Delay, s/veh	1.9					
Movement	EBT	EBR	WBL	WBT	NBL	NBR
Lane Configurations	↑↑		↘	↑	↘	↘
Traffic Vol, veh/h	545	20	81	604	16	78
Future Vol, veh/h	545	20	81	604	16	78
Conflicting Peds, #/hr	0	0	0	0	1	0
Sign Control	Free	Free	Free	Free	Stop	Stop
RT Channelized	-	None	-	None	-	None
Storage Length	-	-	68	-	0	0
Veh in Median Storage, #	0	-	-	0	0	-
Grade, %	0	-	-	0	0	-
Peak Hour Factor	92	92	87	87	78	78
Heavy Vehicles, %	2	2	2	2	2	2
Mvmt Flow	592	22	93	694	21	100

Major/Minor	Major1	Major2	Minor1	Minor2	Minor3
Conflicting Flow All	0	0	614	0	1484 307
Stage 1	-	-	-	-	603 -
Stage 2	-	-	-	-	881 -
Critical Hdwy	-	-	4.13	-	6.63 6.93
Critical Hdwy Stg 1	-	-	-	-	5.83 -
Critical Hdwy Stg 2	-	-	-	-	5.43 -
Follow-up Hdwy	-	-	2.219	-	3.519 3.319
Pot Cap-1 Maneuver	-	-	963	-	126 690
Stage 1	-	-	-	-	510 -
Stage 2	-	-	-	-	404 -
Platoon blocked, %	-	-	-	-	-
Mov Cap-1 Maneuver	-	-	963	-	114 690
Mov Cap-2 Maneuver	-	-	-	-	114 -
Stage 1	-	-	-	-	510 -
Stage 2	-	-	-	-	364 -



















Approach	EB	WB	NB
HCM Control Delay, s	0	1.1	16.6
HCM LOS			C

Minor Lane/Major Mvmt	NBLn1	NBLn2	EBT	EBR	WBL	WBT
Capacity (veh/h)	114	690	-	-	963	-
HCM Lane V/C Ratio	0.18	0.145	-	-	0.097	-
HCM Control Delay (s)	43.4	11.1	-	-	9.1	-
HCM Lane LOS	E	B	-	-	A	-
HCM 95th %tile Q(veh)	0.6	0.5	-	-	0.3	-



HCM Signalized Intersection Capacity Analysis  
6: Conde Lane & Shiloh Road

Existing Project Alter. C Conditions  
Timing Plan: Saturday Midday Peak

												
Movement	EBL	EBT	EBR	WBL	WBT	WBR	NBL	NBT	NBR	SBL	SBT	SBR
Lane Configurations												
Traffic Volume (vph)	29	361	1	9	403	204	1	0	6	197	0	28
Future Volume (vph)	29	361	1	9	403	204	1	0	6	197	0	28
Ideal Flow (vphp)	1900	1900	1900	1900	1900	1900	1900	1900	1900	1900	1900	1900
Total Lost time (s)	4.0	4.0		4.0	4.0			4.0			4.0	4.0
Lane Util. Factor	1.00	0.95		1.00	0.95			1.00			1.00	1.00
Frbp, ped/bikes	1.00	1.00		1.00	0.99			1.00			1.00	1.00
Flpb, ped/bikes	1.00	1.00		1.00	1.00			1.00			1.00	1.00
Frt	1.00	1.00		1.00	0.95			0.89			1.00	0.85
Flt Protected	0.95	1.00		0.95	1.00			0.99			0.95	1.00
Satd. Flow (prot)	1770	3538		1770	3336			1640			1770	1583
Flt Permitted	0.95	1.00		0.95	1.00			0.99			0.95	1.00
Satd. Flow (perm)	1770	3538		1770	3336			1640			1770	1583
Peak-hour factor, PHF	0.96	0.96	0.96	0.91	0.91	0.91	0.58	0.58	0.58	0.78	0.78	0.78
Adj. Flow (vph)	30	376	1	10	443	224	2	0	10	253	0	36
RTOR Reduction (vph)	0	0	0	0	62	0	0	12	0	0	0	0
Lane Group Flow (vph)	30	377	0	10	605	0	0	0	0	0	253	36
Confl. Bikes (#/hr)						2						
Turn Type	Prot	NA		Prot	NA		Split	NA		Split	NA	custom
Protected Phases	5	2		1	6		7	7		4	4	
Permitted Phases												6
Actuated Green, G (s)	0.9	14.5		0.9	14.5			1.1			12.3	14.5
Effective Green, g (s)	0.9	14.5		0.9	14.5			1.1			12.3	14.5
Actuated g/C Ratio	0.02	0.32		0.02	0.32			0.02			0.27	0.32
Clearance Time (s)	4.0	4.0		4.0	4.0			4.0			4.0	4.0
Vehicle Extension (s)	3.0	3.0		3.0	3.0			3.0			3.0	3.0
Lane Grp Cap (vph)	35	1145		35	1079			40			485	512
v/s Ratio Prot	c0.02	0.11		0.01	c0.18			c0.00			c0.14	
v/s Ratio Perm												0.02
v/c Ratio	0.86	0.33		0.29	0.56			0.01			0.52	0.07
Uniform Delay, d1	21.9	11.5		21.6	12.5			21.3			13.8	10.5
Progression Factor	1.00	1.00		1.00	1.00			1.00			1.00	1.00
Incremental Delay, d2	94.8	0.2		4.5	0.7			0.1			1.0	0.1
Delay (s)	116.7	11.6		26.1	13.2			21.4			14.8	10.5
Level of Service	F	B		C	B			C			B	B
Approach Delay (s)		19.4			13.4			21.4			14.2	
Approach LOS		B			B			C			B	
<b>Intersection Summary</b>												
HCM 2000 Control Delay			15.4			HCM 2000 Level of Service				B		
HCM 2000 Volume to Capacity ratio			0.53									
Actuated Cycle Length (s)			44.8			Sum of lost time (s)			16.0			
Intersection Capacity Utilization			48.3%			ICU Level of Service				A		
Analysis Period (min)			15									
c Critical Lane Group												

HCM 6th TWSC  
7: Entrance 1/Gridley Drive & Shiloh Road

Existing Project Alter. C Conditions  
Timing Plan: Saturday Midday Peak

Intersection												
Int Delay, s/veh	4.3											
Movement	EBL	EBT	EBR	WBL	WBT	WBR	NBL	NBT	NBR	SBL	SBT	SBR
Lane Configurations		↕			↕		↕	↕			↕	
Traffic Vol, veh/h	20	106	118	8	92	0	133	0	9	0	0	18
Future Vol, veh/h	20	106	118	8	92	0	133	0	9	0	0	18
Conflicting Peds, #/hr	1	0	0	0	0	0	0	0	0	0	0	0
Sign Control	Free	Free	Free	Free	Free	Free	Stop	Stop	Stop	Stop	Stop	Stop
RT Channelized	-	-	None	-	-	None	-	-	None	-	-	None
Storage Length	-	-	-	-	-	-	0	-	-	-	-	-
Veh in Median Storage, #	-	0	-	-	0	-	-	0	-	-	0	-
Grade, %	-	0	-	-	0	-	-	0	-	-	0	-
Peak Hour Factor	93	93	93	88	88	88	100	100	100	56	56	56
Heavy Vehicles, %	2	2	2	2	2	2	2	2	2	2	2	2
Mvmt Flow	22	114	127	9	105	0	133	0	9	0	0	32

Major/Minor	Major1			Major2			Minor1			Minor2		
Conflicting Flow All	106	0	0	241	0	0	361	346	178	350	409	106
Stage 1	-	-	-	-	-	-	222	222	-	124	124	-
Stage 2	-	-	-	-	-	-	139	124	-	226	285	-
Critical Hdwy	4.12	-	-	4.12	-	-	7.12	6.52	6.22	7.12	6.52	6.22
Critical Hdwy Stg 1	-	-	-	-	-	-	6.12	5.52	-	6.12	5.52	-
Critical Hdwy Stg 2	-	-	-	-	-	-	6.12	5.52	-	6.12	5.52	-
Follow-up Hdwy	2.218	-	-	2.218	-	-	3.518	4.018	3.318	3.518	4.018	3.318
Pot Cap-1 Maneuver	1485	-	-	1326	-	-	595	577	865	605	532	948
Stage 1	-	-	-	-	-	-	780	720	-	880	793	-
Stage 2	-	-	-	-	-	-	864	793	-	777	676	-
Platoon blocked, %		-	-		-	-						
Mov Cap-1 Maneuver	1484	-	-	1326	-	-	564	563	865	587	519	947
Mov Cap-2 Maneuver	-	-	-	-	-	-	564	563	-	587	519	-
Stage 1	-	-	-	-	-	-	767	708	-	864	787	-
Stage 2	-	-	-	-	-	-	829	787	-	756	665	-

Approach	EB			WB			NB			SB		
HCM Control Delay, s	0.6			0.6			13			8.9		
HCM LOS							B			A		

Minor Lane/Major Mvmt	NBLn1	NBLn2	EBL	EBT	EBR	WBL	WBT	WBR	SBLn1
Capacity (veh/h)	564	865	1484	-	-	1326	-	-	947
HCM Lane V/C Ratio	0.236	0.01	0.014	-	-	0.007	-	-	0.034
HCM Control Delay (s)	13.3	9.2	7.5	0	-	7.7	0	-	8.9
HCM Lane LOS	B	A	A	A	-	A	A	-	A
HCM 95th %tile Q(veh)	0.9	0	0	-	-	0	-	-	0.1

HCM 6th TWSC  
8: Old Redwood Hwy & Entrance 1

Existing Project Alter. C Conditions  
Timing Plan: Saturday Midday Peak

Intersection												
Int Delay, s/veh	1.2											
Movement	EBL	EBT	EBR	WBL	WBT	WBR	NBL	NBT	NBR	SBL	SBT	SBR
Lane Configurations		↕		↕	↕			↕		↕	↕	
Traffic Vol, veh/h	1	0	2	19	0	31	1	403	17	27	342	4
Future Vol, veh/h	1	0	2	19	0	31	1	403	17	27	342	4
Conflicting Peds, #/hr	0	0	0	0	0	0	1	0	4	4	0	1
Sign Control	Stop	Stop	Stop	Stop	Stop	Stop	Free	Free	Free	Free	Free	Free
RT Channelized	-	-	None	-	-	None	-	-	None	-	-	None
Storage Length	-	-	-	0	-	-	-	-	-	50	-	-
Veh in Median Storage, #	-	0	-	-	0	-	-	0	-	-	0	-
Grade, %	-	0	-	-	0	-	-	0	-	-	0	-
Peak Hour Factor	38	38	38	100	100	100	94	94	94	93	93	93
Heavy Vehicles, %	2	2	2	2	2	2	2	2	2	2	2	2
Mvmt Flow	3	0	5	19	0	31	1	429	18	29	368	4

Major/Minor	Minor2		Minor1		Major1		Major2					
Conflicting Flow All	885	882	371	875	875	442	373	0	0	451	0	0
Stage 1	429	429	-	444	444	-	-	-	-	-	-	-
Stage 2	456	453	-	431	431	-	-	-	-	-	-	-
Critical Hdwy	7.12	6.52	6.22	7.12	6.52	6.22	4.12	-	-	4.12	-	-
Critical Hdwy Stg 1	6.12	5.52	-	6.12	5.52	-	-	-	-	-	-	-
Critical Hdwy Stg 2	6.12	5.52	-	6.12	5.52	-	-	-	-	-	-	-
Follow-up Hdwy	3.518	4.018	3.318	3.518	4.018	3.318	2.218	-	-	2.218	-	-
Pot Cap-1 Maneuver	266	285	675	270	288	615	1185	-	-	1109	-	-
Stage 1	604	584	-	593	575	-	-	-	-	-	-	-
Stage 2	584	570	-	603	583	-	-	-	-	-	-	-
Platoon blocked, %								-	-	-	-	-
Mov Cap-1 Maneuver	247	276	674	261	279	613	1184	-	-	1105	-	-
Mov Cap-2 Maneuver	247	276	-	261	279	-	-	-	-	-	-	-
Stage 1	603	568	-	590	572	-	-	-	-	-	-	-
Stage 2	554	567	-	583	567	-	-	-	-	-	-	-

Approach	EB		WB		NB		SB	
HCM Control Delay, s	13.6		14.5		0		0.6	
HCM LOS	B		B					

Minor Lane/Major Mvmt	NBL	NBT	NBR	EBLn1	WBLn1	WBLn2	SBL	SBT	SBR
Capacity (veh/h)	1184	-	-	428	261	613	1105	-	-
HCM Lane V/C Ratio	0.001	-	-	0.018	0.073	0.051	0.026	-	-
HCM Control Delay (s)	8	0	-	13.6	19.9	11.2	8.3	-	-
HCM Lane LOS	A	A	-	B	C	B	A	-	-
HCM 95th %tile Q(veh)	0	-	-	0.1	0.2	0.2	0.1	-	-

Intersection						
Int Delay, s/veh	0					
Movement	EBT	EBR	WBL	WBT	NBL	NBR
Lane Configurations	↔			↔	↔	↔
Traffic Vol, veh/h	101	0	0	94	0	0
Future Vol, veh/h	101	0	0	94	0	0
Conflicting Peds, #/hr	0	1	0	0	0	0
Sign Control	Free	Free	Free	Free	Stop	Stop
RT Channelized	-	None	-	None	-	None
Storage Length	-	-	-	-	0	0
Veh in Median Storage, #	0	-	-	0	0	-
Grade, %	0	-	-	0	0	-
Peak Hour Factor	88	88	80	80	100	100
Heavy Vehicles, %	2	2	2	2	2	2
Mvmt Flow	115	0	0	118	0	0

Major/Minor	Major1	Major2	Minor1		
Conflicting Flow All	0	0	116	0	234
Stage 1	-	-	-	-	116
Stage 2	-	-	-	-	118
Critical Hdwy	-	-	4.12	-	6.42
Critical Hdwy Stg 1	-	-	-	-	5.42
Critical Hdwy Stg 2	-	-	-	-	5.42
Follow-up Hdwy	-	-	2.218	-	3.518
Pot Cap-1 Maneuver	-	-	1473	-	754
Stage 1	-	-	-	-	909
Stage 2	-	-	-	-	907
Platoon blocked, %	-	-	-	-	-
Mov Cap-1 Maneuver	-	-	1472	-	753
Mov Cap-2 Maneuver	-	-	-	-	753
Stage 1	-	-	-	-	908
Stage 2	-	-	-	-	907

Approach	EB	WB	NB
HCM Control Delay, s	0	0	0
HCM LOS			A

Minor Lane/Major Mvmt	NBLn1	NBLn2	EBT	EBR	WBL	WBT
Capacity (veh/h)	-	-	-	-	1472	-
HCM Lane V/C Ratio	-	-	-	-	-	-
HCM Control Delay (s)	0	0	-	-	0	-
HCM Lane LOS	A	A	-	-	A	-
HCM 95th %tile Q(veh)	-	-	-	-	0	-

HCM 6th Signalized Intersection Summary

Existing Project Alter. C Conditions

10: US 101 NB Off Ramp/Lakewood Drive & Old Redwood Highway Timing Plan: Saturday Midday Peak



Movement	EBL	EBT	EBR	WBL	WBT	WBR	NBL	NBT	NBR	SBL	SBT	SBR
Lane Configurations												
Traffic Volume (veh/h)	252	292	0	0	460	242	281	266	125	214	0	615
Future Volume (veh/h)	252	292	0	0	460	242	281	266	125	214	0	615
Initial Q (Qb), veh	0	0	0	0	0	0	0	0	0	0	0	0
Ped-Bike Adj(A_pbT)	1.00		1.00	1.00		0.99	1.00		1.00	1.00		1.00
Parking Bus, Adj	1.00	1.00	1.00	1.00	1.00	1.00	1.00	1.00	1.00	1.00	1.00	1.00
Work Zone On Approach		No			No			No			No	
Adj Sat Flow, veh/h/ln	1870	1870	0	0	1870	1870	1870	1870	1870	1870	0	1870
Adj Flow Rate, veh/h	265	307	0	0	517	272	229	353	128	243	0	0
Peak Hour Factor	0.95	0.95	0.95	0.89	0.89	0.89	0.98	0.98	0.98	0.88	0.88	0.88
Percent Heavy Veh, %	2	2	0	0	2	2	2	2	2	2	0	2
Cap, veh/h	377	1183	0	0	1031	541	380	562	200	0	0	0
Arrive On Green	0.11	0.63	0.00	0.00	0.46	0.46	0.21	0.21	0.21	0.00	0.00	0.00
Sat Flow, veh/h	3456	1870	0	0	2334	1175	1781	2632	938		0	
Grp Volume(v), veh/h	265	307	0	0	410	379	229	249	232		0.0	
Grp Sat Flow(s),veh/h/ln	1728	1870	0	0	1777	1638	1781	1870	1700			
Q Serve(g_s), s	4.7	4.6	0.0	0.0	10.3	10.3	7.4	7.7	7.9			
Cycle Q Clear(g_c), s	4.7	4.6	0.0	0.0	10.3	10.3	7.4	7.7	7.9			
Prop In Lane	1.00		0.00	0.00		0.72	1.00		0.55			
Lane Grp Cap(c), veh/h	377	1183	0	0	818	754	380	399	363			
V/C Ratio(X)	0.70	0.26	0.00	0.00	0.50	0.50	0.60	0.62	0.64			
Avail Cap(c_a), veh/h	435	1183	0	0	818	754	813	853	775			
HCM Platoon Ratio	1.00	1.00	1.00	1.00	1.00	1.00	1.00	1.00	1.00			
Upstream Filter(I)	1.00	1.00	0.00	0.00	1.00	1.00	1.00	1.00	1.00			
Uniform Delay (d), s/veh	27.3	5.1	0.0	0.0	12.0	12.0	22.6	22.7	22.8			
Incr Delay (d2), s/veh	4.2	0.5	0.0	0.0	2.2	2.4	1.5	1.6	1.9			
Initial Q Delay(d3),s/veh	0.0	0.0	0.0	0.0	0.0	0.0	0.0	0.0	0.0			
%ile BackOfQ(50%),veh/ln	2.0	1.4	0.0	0.0	3.9	3.7	3.1	3.3	3.1			
Unsig. Movement Delay, s/veh												
LnGrp Delay(d),s/veh	31.6	5.7	0.0	0.0	14.2	14.4	24.1	24.3	24.6			
LnGrp LOS	C	A	A	A	B	B	C	C	C			
Approach Vol, veh/h		572			789			710				
Approach Delay, s/veh		17.7			14.3			24.3				
Approach LOS		B			B			C				
Timer - Assigned Phs		2			5	6		8				
Phs Duration (G+Y+Rc), s		45.3			10.9	34.4		18.3				
Change Period (Y+Rc), s		5.1			4.0	5.1		4.7				
Max Green Setting (Gmax), s		40.2			8.0	28.2		29.0				
Max Q Clear Time (g_c+I1), s		6.6			6.7	12.3		9.9				
Green Ext Time (p_c), s		1.9			0.1	4.5		3.5				

Intersection Summary

HCM 6th Ctrl Delay	18.7
HCM 6th LOS	B

Notes

User approved volume balancing among the lanes for turning movement.  
 Unsignalized Delay for [SBR] is excluded from calculations of the approach delay and intersection delay.

HCM 6th Signalized Intersection Summary

Existing Project Alter. C Conditions

12: US 101 SB On Ramp/US 101 SB Off Ramp & Old Redwood Highway Timing Plan: Saturday Midday Peak



Movement	EBL	EBT	EBR	WBL	WBT	WBR	NBL	NBT	NBR	SBL	SBT	SBR
Lane Configurations		↑↑	↗	↘	↑↑					↖	↕	
Traffic Volume (veh/h)	0	483	368	428	718	0	0	0	0	150	1	76
Future Volume (veh/h)	0	483	368	428	718	0	0	0	0	150	1	76
Initial Q (Qb), veh	0	0	0	0	0	0				0	0	0
Ped-Bike Adj(A_pbT)	1.00		0.98	1.00		1.00				1.00		1.00
Parking Bus, Adj	1.00	1.00	1.00	1.00	1.00	1.00				1.00	1.00	1.00
Work Zone On Approach		No			No						No	
Adj Sat Flow, veh/h/ln	0	1870	1870	1870	1870	0				1870	1870	1870
Adj Flow Rate, veh/h	0	498	379	446	748	0				158	72	0
Peak Hour Factor	0.97	0.97	0.97	0.96	0.96	0.96				0.72	0.72	0.72
Percent Heavy Veh, %	0	2	2	2	2	0				2	2	2
Cap, veh/h	0	1383	605	484	2553	0				252	265	
Arrive On Green	0.00	0.39	0.39	0.27	0.72	0.00				0.14	0.14	0.00
Sat Flow, veh/h	0	3647	1555	1781	3647	0				1781	1870	0
Grp Volume(v), veh/h	0	498	379	446	748	0				158	72	0
Grp Sat Flow(s),veh/h/ln	0	1777	1555	1781	1777	0				1781	1870	0
Q Serve(g_s), s	0.0	7.0	13.8	17.0	5.2	0.0				5.8	2.4	0.0
Cycle Q Clear(g_c), s	0.0	7.0	13.8	17.0	5.2	0.0				5.8	2.4	0.0
Prop In Lane	0.00		1.00	1.00		0.00				1.00		0.00
Lane Grp Cap(c), veh/h	0	1383	605	484	2553	0				252	265	
V/C Ratio(X)	0.00	0.36	0.63	0.92	0.29	0.00				0.63	0.27	
Avail Cap(c_a), veh/h	0	1383	605	484	2553	0				255	268	
HCM Platoon Ratio	1.00	1.00	1.00	1.00	1.00	1.00				1.00	1.00	1.00
Upstream Filter(I)	0.00	1.00	1.00	1.00	1.00	0.00				1.00	1.00	0.00
Uniform Delay (d), s/veh	0.0	15.2	17.2	24.7	3.5	0.0				28.3	26.8	0.0
Incr Delay (d2), s/veh	0.0	0.7	4.8	23.1	0.3	0.0				4.7	0.5	0.0
Initial Q Delay(d3),s/veh	0.0	0.0	0.0	0.0	0.0	0.0				0.0	0.0	0.0
%ile BackOfQ(50%),veh/ln	0.0	2.7	5.2	9.7	1.2	0.0				2.7	1.1	0.0
Unsig. Movement Delay, s/veh												
LnGrp Delay(d),s/veh	0.0	15.9	22.1	47.8	3.8	0.0				33.0	27.3	0.0
LnGrp LOS	A	B	C	D	A	A				C	C	
Approach Vol, veh/h		877			1194						230	
Approach Delay, s/veh		18.6			20.2						31.2	
Approach LOS		B			C						C	
Timer - Assigned Phs		2			5	6		8				
Phs Duration (G+Y+Rc), s		55.3			23.0	32.3		14.6				
Change Period (Y+Rc), s		5.1			4.0	5.1		4.7				
Max Green Setting (Gmax), s		50.2			19.0	27.2		10.0				
Max Q Clear Time (g_c+I1), s		7.2			19.0	15.8		7.8				
Green Ext Time (p_c), s		5.9			0.0	3.6		0.2				

Intersection Summary

HCM 6th Ctrl Delay	20.7
HCM 6th LOS	C

Notes

- User approved volume balancing among the lanes for turning movement.
- User approved ignoring U-Turning movement.
- Unsignalized Delay for [SBR] is excluded from calculations of the approach delay and intersection delay.

Queues  
1: Old Redwood Hwy & Shiloh Road

Existing Project Alter. C Conditions  
Timing Plan: A.M. PEAK



Lane Group	EBL	EBT	EBR	WBT	WBR	NBL	NBT	NBR	SBL	SBT	SBR
Lane Group Flow (vph)	133	198	96	125	18	80	131	37	24	271	199
v/c Ratio	0.36	0.51	0.23	0.40	0.05	0.32	0.20	0.06	0.14	0.58	0.41
Control Delay	29.6	32.0	7.1	34.0	0.2	35.1	18.2	1.0	38.7	30.0	13.3
Queue Delay	0.0	0.0	0.0	0.0	0.0	0.0	0.0	0.0	0.0	0.0	0.0
Total Delay	29.6	32.0	7.1	34.0	0.2	35.1	18.2	1.0	38.7	30.0	13.3
Queue Length 50th (ft)	47	72	0	46	0	30	31	0	9	97	24
Queue Length 95th (ft)	107	152	26	121	0	88	97	4	37	204	83
Internal Link Dist (ft)		1709		528			668			695	
Turn Bay Length (ft)	375		140		50	200		98	130		93
Base Capacity (vph)	882	928	841	1145	1022	419	1279	1111	173	1065	939
Starvation Cap Reductn	0	0	0	0	0	0	0	0	0	0	0
Spillback Cap Reductn	0	0	0	0	0	0	0	0	0	0	0
Storage Cap Reductn	0	0	0	0	0	0	0	0	0	0	0
Reduced v/c Ratio	0.15	0.21	0.11	0.11	0.02	0.19	0.10	0.03	0.14	0.25	0.21

Intersection Summary

Queues

2: Shiloh Road & Hembree Ln

Existing Project Alter. C Conditions

Timing Plan: A.M. PEAK

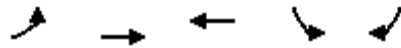

Lane Group	EBL	EBT	WBT	SBL	SBR
Lane Group Flow (vph)	347	334	371	76	384
v/c Ratio	0.34	0.23	0.37	0.20	0.41
Control Delay	12.6	3.6	12.1	16.3	2.2
Queue Delay	0.0	0.0	0.0	0.0	0.0
Total Delay	12.6	3.6	12.1	16.3	2.2
Queue Length 50th (ft)	31	26	31	14	0
Queue Length 95th (ft)	65	59	70	46	25
Internal Link Dist (ft)		222	1709	301	
Turn Bay Length (ft)					
Base Capacity (vph)	2565	1863	3271	724	1484
Starvation Cap Reductn	0	0	0	0	0
Spillback Cap Reductn	0	0	0	0	0
Storage Cap Reductn	0	0	0	0	0
Reduced v/c Ratio	0.14	0.18	0.11	0.10	0.26

Intersection Summary



Queues  
3: US 101 NB Off-Ramp & Shiloh Road

Existing Project Alter. C Conditions  
Timing Plan: A.M. PEAK

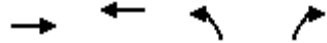

Lane Group	EBT	WBT	NBL	NBR
Lane Group Flow (vph)	270	572	568	482
v/c Ratio	0.18	0.74	0.76	0.33
Control Delay	11.1	21.0	22.2	2.1
Queue Delay	0.0	0.0	0.0	0.0
Total Delay	11.1	21.0	22.2	2.1
Queue Length 50th (ft)	28	152	149	0
Queue Length 95th (ft)	56	298	245	11
Internal Link Dist (ft)	106	291	689	
Turn Bay Length (ft)				265
Base Capacity (vph)	2331	1227	1107	1923
Starvation Cap Reductn	0	0	0	0
Spillback Cap Reductn	0	0	0	0
Storage Cap Reductn	0	0	0	0
Reduced v/c Ratio	0.12	0.47	0.51	0.25
<b>Intersection Summary</b>				

Queues  
4: Shiloh Road & US 101 SB Off-Ramp

Existing Project Alter. C Conditions  
Timing Plan: A.M. PEAK

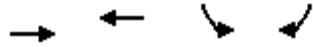

Lane Group	EBT	WBT	SBL	SBR
Lane Group Flow (vph)	248	645	112	150
v/c Ratio	0.21	0.54	0.24	0.29
Control Delay	4.6	7.3	14.7	5.3
Queue Delay	0.0	0.0	0.0	0.0
Total Delay	4.6	7.3	14.7	5.3
Queue Length 50th (ft)	19	66	16	0
Queue Length 95th (ft)	49	155	59	34
Internal Link Dist (ft)	145	226	406	
Turn Bay Length (ft)				275
Base Capacity (vph)	1863	1863	1020	976
Starvation Cap Reductn	0	0	0	0
Spillback Cap Reductn	0	0	0	0
Storage Cap Reductn	0	0	0	0
Reduced v/c Ratio	0.13	0.35	0.11	0.15
<b>Intersection Summary</b>				

Queues  
6: Conde Lane & Shiloh Road

Existing Project Alter. C Conditions  
Timing Plan: A.M. PEAK

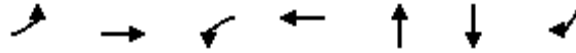

Lane Group	EBL	EBT	WBL	WBT	NBT	SBT	SBR
Lane Group Flow (vph)	26	350	11	656	28	239	41
v/c Ratio	0.07	0.27	0.03	0.55	0.06	0.46	0.08
Control Delay	23.6	11.2	23.8	13.1	0.2	24.8	14.1
Queue Delay	0.0	0.0	0.0	0.0	0.0	0.0	0.0
Total Delay	23.6	11.2	23.8	13.1	0.2	24.8	14.1
Queue Length 50th (ft)	3	18	1	30	0	29	4
Queue Length 95th (ft)	30	86	16	128	0	#195	29
Internal Link Dist (ft)		735		1001	338	442	
Turn Bay Length (ft)	90		127				40
Base Capacity (vph)	424	3025	376	2862	1344	519	1346
Starvation Cap Reductn	0	0	0	0	0	0	0
Spillback Cap Reductn	0	0	0	0	0	0	0
Storage Cap Reductn	0	0	0	0	0	0	0
Reduced v/c Ratio	0.06	0.12	0.03	0.23	0.02	0.46	0.03

Intersection Summary

# 95th percentile volume exceeds capacity, queue may be longer.  
Queue shown is maximum after two cycles.

## Queues

## 10: US 101 NB Off Ramp/Lakewood Drive &amp; Old Redwood Highway

Existing Project Alter. C Conditions

Timing Plan: A.M. PEAK



Lane Group	EBL	EBT	WBT	NBL	NBT	SBL	SBR
Lane Group Flow (vph)	179	186	717	194	392	133	600
v/c Ratio	0.48	0.19	0.57	0.59	0.56	0.42	0.76
Control Delay	37.6	11.4	21.3	35.0	27.4	38.9	16.8
Queue Delay	0.0	0.0	0.0	0.0	0.0	0.0	0.0
Total Delay	37.6	11.4	21.3	35.0	27.4	38.9	16.8
Queue Length 50th (ft)	41	43	130	92	82	31	116
Queue Length 95th (ft)	74	89	192	161	125	62	233
Internal Link Dist (ft)		146	537		636		
Turn Bay Length (ft)	155			270		120	
Base Capacity (vph)	403	976	1262	608	1250	313	795
Starvation Cap Reductn	0	0	0	0	0	0	0
Spillback Cap Reductn	0	0	0	0	0	0	0
Storage Cap Reductn	0	0	0	0	0	0	0
Reduced v/c Ratio	0.44	0.19	0.57	0.32	0.31	0.42	0.75

## Intersection Summary

Queues

Existing Project Alter. C Conditions

12: US 101 SB On Ramp/US 101 SB Off Ramp & Old Redwood Highway

Timing Plan: A.M. PEAK



Lane Group	EBT	EBR	WBL	WBT	SBL	SBT
Lane Group Flow (vph)	324	322	576	566	107	99
v/c Ratio	0.24	0.41	0.92	0.20	0.49	0.37
Control Delay	18.7	4.2	47.4	2.8	40.9	15.7
Queue Delay	0.0	0.0	0.0	0.0	0.0	0.0
Total Delay	18.7	4.2	47.4	2.8	40.9	15.7
Queue Length 50th (ft)	61	0	267	34	53	9
Queue Length 95th (ft)	93	52	#451	46	93	44
Internal Link Dist (ft)	343			451		751
Turn Bay Length (ft)			250		420	
Base Capacity (vph)	1350	793	670	2838	219	270
Starvation Cap Reductn	0	0	0	0	0	0
Spillback Cap Reductn	0	0	0	0	0	0
Storage Cap Reductn	0	0	0	0	0	0
Reduced v/c Ratio	0.24	0.41	0.86	0.20	0.49	0.37

Intersection Summary

# 95th percentile volume exceeds capacity, queue may be longer.  
 Queue shown is maximum after two cycles.

Queues  
1: Old Redwood Hwy & Shiloh Road

Existing Project Alter. C Conditions  
Timing Plan: P.M. Peak



Lane Group	EBL	EBT	EBR	WBT	WBR	NBL	NBT	NBR	SBL	SBT	SBR
Lane Group Flow (vph)	248	151	179	192	25	165	365	23	33	253	157
v/c Ratio	0.63	0.36	0.36	0.58	0.07	0.56	0.54	0.04	0.25	0.64	0.38
Control Delay	38.5	31.9	7.2	41.0	0.3	44.8	28.0	0.1	48.6	39.5	15.1
Queue Delay	0.0	0.0	0.0	0.0	0.0	0.0	0.0	0.0	0.0	0.0	0.0
Total Delay	38.5	31.9	7.2	41.0	0.3	44.8	28.0	0.1	48.6	39.5	15.1
Queue Length 50th (ft)	115	66	0	91	0	77	158	0	16	119	22
Queue Length 95th (ft)	234	144	53	197	0	#211	320	0	56	242	86
Internal Link Dist (ft)		1709		528			668			695	
Turn Bay Length (ft)	375		140		50	200		98	130		93
Base Capacity (vph)	688	725	725	893	805	327	1033	892	135	831	746
Starvation Cap Reductn	0	0	0	0	0	0	0	0	0	0	0
Spillback Cap Reductn	0	0	0	0	0	0	0	0	0	0	0
Storage Cap Reductn	0	0	0	0	0	0	0	0	0	0	0
Reduced v/c Ratio	0.36	0.21	0.25	0.22	0.03	0.50	0.35	0.03	0.24	0.30	0.21

Intersection Summary

# 95th percentile volume exceeds capacity, queue may be longer.  
Queue shown is maximum after two cycles.

Queues

2: Shiloh Road & Hembree Ln

Existing Project Alter. C Conditions

Timing Plan: P.M. Peak

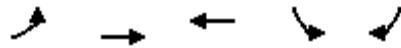

Lane Group	EBL	EBT	WBT	SBL	SBR
Lane Group Flow (vph)	654	436	530	179	517
v/c Ratio	0.60	0.36	0.58	0.50	0.47
Control Delay	18.7	5.4	18.0	27.1	3.5
Queue Delay	0.0	0.0	0.0	0.0	0.0
Total Delay	18.7	5.4	18.0	27.1	3.5
Queue Length 50th (ft)	92	55	63	52	18
Queue Length 95th (ft)	155	96	118	127	62
Internal Link Dist (ft)		222	1709	301	
Turn Bay Length (ft)					
Base Capacity (vph)	1636	1863	2584	438	1286
Starvation Cap Reductn	0	0	0	0	0
Spillback Cap Reductn	0	0	0	0	0
Storage Cap Reductn	0	0	0	0	0
Reduced v/c Ratio	0.40	0.23	0.21	0.41	0.40

Intersection Summary

Queues  
3: US 101 NB Off-Ramp & Shiloh Road

Existing Project Alter. C Conditions  
Timing Plan: P.M. Peak

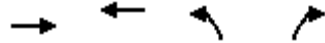

Lane Group	EBT	WBT	NBL	NBR
Lane Group Flow (vph)	403	579	584	723
v/c Ratio	0.28	0.75	0.76	0.46
Control Delay	11.9	21.9	22.7	3.4
Queue Delay	0.0	0.0	0.0	0.0
Total Delay	11.9	21.9	22.7	3.4
Queue Length 50th (ft)	47	168	163	11
Queue Length 95th (ft)	82	303	#352	49
Internal Link Dist (ft)	106	291	689	
Turn Bay Length (ft)				265
Base Capacity (vph)	2248	1183	1056	1911
Starvation Cap Reductn	0	0	0	0
Spillback Cap Reductn	0	0	0	0
Storage Cap Reductn	0	0	0	0
Reduced v/c Ratio	0.18	0.49	0.55	0.38

Intersection Summary

# 95th percentile volume exceeds capacity, queue may be longer.  
Queue shown is maximum after two cycles.



Queues  
4: Shiloh Road & US 101 SB Off-Ramp

Existing Project Alter. C Conditions  
Timing Plan: P.M. Peak

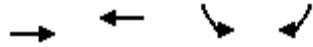

Lane Group	EBT	WBT	SBL	SBR
Lane Group Flow (vph)	481	646	158	118
v/c Ratio	0.40	0.54	0.32	0.23
Control Delay	6.2	7.7	15.8	5.3
Queue Delay	0.0	0.0	0.0	0.0
Total Delay	6.2	7.7	15.8	5.3
Queue Length 50th (ft)	47	72	25	0
Queue Length 95th (ft)	113	175	82	30
Internal Link Dist (ft)	145	226	406	
Turn Bay Length (ft)				275
Base Capacity (vph)	1863	1863	979	908
Starvation Cap Reductn	0	0	0	0
Spillback Cap Reductn	0	0	0	0
Storage Cap Reductn	0	0	0	0
Reduced v/c Ratio	0.26	0.35	0.16	0.13
<b>Intersection Summary</b>				

Queues  
6: Conde Lane & Shiloh Road

Existing Project Alter. C Conditions  
Timing Plan: P.M. Peak

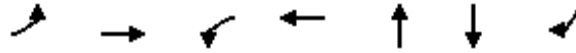

Lane Group	EBL	EBT	WBL	WBT	NBT	SBT	SBR
Lane Group Flow (vph)	78	542	9	937	40	338	44
v/c Ratio	0.28	0.31	0.03	0.70	0.12	0.93	0.07
Control Delay	32.9	10.4	31.7	17.6	17.6	67.2	14.5
Queue Delay	0.0	0.0	0.0	0.0	0.0	0.0	0.0
Total Delay	32.9	10.4	31.7	17.6	17.6	67.2	14.5
Queue Length 50th (ft)	32	63	4	156	5	~185	13
Queue Length 95th (ft)	77	124	16	180	19	#376	31
Internal Link Dist (ft)		735		1001	338	442	
Turn Bay Length (ft)	90		127				40
Base Capacity (vph)	299	2514	265	2354	1019	365	1106
Starvation Cap Reductn	0	0	0	0	0	0	0
Spillback Cap Reductn	0	0	0	0	0	0	0
Storage Cap Reductn	0	0	0	0	0	0	0
Reduced v/c Ratio	0.26	0.22	0.03	0.40	0.04	0.93	0.04

Intersection Summary

~ Volume exceeds capacity, queue is theoretically infinite.

Queue shown is maximum after two cycles.

# 95th percentile volume exceeds capacity, queue may be longer.

Queue shown is maximum after two cycles.

Queues

10: US 101 NB Off Ramp/Lakewood Drive & Old Redwood Highway

Existing Project Alter. C Conditions

Timing Plan: P.M. Peak



Lane Group	EBL	EBT	WBT	NBL	NBT	SBL	SBR
Lane Group Flow (vph)	300	414	767	424	840	259	601
v/c Ratio	0.86	0.49	0.71	0.85	0.80	0.95	0.67
Control Delay	64.1	19.8	29.4	46.2	31.9	87.1	12.9
Queue Delay	0.0	0.0	0.0	0.0	0.0	0.0	0.0
Total Delay	64.1	19.8	29.4	46.2	31.9	87.1	12.9
Queue Length 50th (ft)	88	162	187	241	212	77	121
Queue Length 95th (ft)	#151	234	254	#413	290	#153	241
Internal Link Dist (ft)		146	537		636		
Turn Bay Length (ft)	155			270		120	
Base Capacity (vph)	349	847	1081	527	1100	272	895
Starvation Cap Reductn	0	0	0	0	0	0	0
Spillback Cap Reductn	0	0	0	0	0	0	0
Storage Cap Reductn	0	0	0	0	0	0	0
Reduced v/c Ratio	0.86	0.49	0.71	0.80	0.76	0.95	0.67

Intersection Summary

# 95th percentile volume exceeds capacity, queue may be longer.  
 Queue shown is maximum after two cycles.

## Queues

Existing Project Alter. C Conditions

12: US 101 SB On Ramp/US 101 SB Off Ramp &amp; Old Redwood Highway

Timing Plan: P.M. Peak



Lane Group	EBT	EBR	WBL	WBT	SBL	SBT
Lane Group Flow (vph)	569	405	428	1151	192	176
v/c Ratio	0.40	0.47	0.94	0.46	0.78	0.54
Control Delay	16.1	3.7	58.1	5.0	52.8	17.2
Queue Delay	0.0	0.0	0.0	0.0	0.0	0.0
Total Delay	16.1	3.7	58.1	5.0	52.8	17.2
Queue Length 50th (ft)	89	0	180	87	85	22
Queue Length 95th (ft)	128	49	#340	116	#165	67
Internal Link Dist (ft)	343			451		751
Turn Bay Length (ft)			250		420	
Base Capacity (vph)	1411	864	455	2524	247	327
Starvation Cap Reductn	0	0	0	0	0	0
Spillback Cap Reductn	0	0	0	0	0	0
Storage Cap Reductn	0	0	0	0	0	0
Reduced v/c Ratio	0.40	0.47	0.94	0.46	0.78	0.54

## Intersection Summary

# 95th percentile volume exceeds capacity, queue may be longer.

Queue shown is maximum after two cycles.

Queues  
1: Old Redwood Hwy & Shiloh Road

Existing Project Alter. C Conditions  
Timing Plan: Saturday Midday Peak



Lane Group	EBL	EBT	EBR	WBT	WBR	NBL	NBT	NBR	SBL	SBT	SBR
Lane Group Flow (vph)	138	197	191	243	35	190	251	26	37	205	198
v/c Ratio	0.42	0.56	0.43	0.63	0.08	0.56	0.37	0.04	0.27	0.58	0.47
Control Delay	34.2	37.5	8.3	37.8	0.4	41.2	24.5	0.1	45.9	38.0	12.2
Queue Delay	0.0	0.0	0.0	0.0	0.0	0.0	0.0	0.0	0.0	0.0	0.0
Total Delay	34.2	37.5	8.3	37.8	0.4	41.2	24.5	0.1	45.9	38.0	12.2
Queue Length 50th (ft)	58	86	0	105	0	82	95	0	17	89	13
Queue Length 95th (ft)	133	182	54	210	0	#234	208	0	58	192	80
Internal Link Dist (ft)		1709		528			668			695	
Turn Bay Length (ft)	375		140		50	200		98	130		93
Base Capacity (vph)	709	746	735	924	842	337	1064	918	139	856	796
Starvation Cap Reductn	0	0	0	0	0	0	0	0	0	0	0
Spillback Cap Reductn	0	0	0	0	0	0	0	0	0	0	0
Storage Cap Reductn	0	0	0	0	0	0	0	0	0	0	0
Reduced v/c Ratio	0.19	0.26	0.26	0.26	0.04	0.56	0.24	0.03	0.27	0.24	0.25

Intersection Summary

# 95th percentile volume exceeds capacity, queue may be longer.  
Queue shown is maximum after two cycles.

Queues

2: Shiloh Road & Hembree Ln

Existing Project Alter. C Conditions

Timing Plan: Saturday Midday Peak

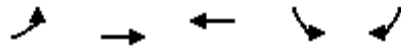

Lane Group	EBL	EBT	WBT	SBL	SBR
Lane Group Flow (vph)	662	404	526	176	637
v/c Ratio	0.58	0.33	0.59	0.50	0.57
Control Delay	18.1	5.2	18.2	27.2	4.9
Queue Delay	0.0	0.0	0.0	0.0	0.0
Total Delay	18.1	5.2	18.2	27.2	4.9
Queue Length 50th (ft)	90	49	62	51	32
Queue Length 95th (ft)	156	88	122	124	107
Internal Link Dist (ft)		222	1709	301	
Turn Bay Length (ft)					
Base Capacity (vph)	1630	1863	2570	437	1284
Starvation Cap Reductn	0	0	0	0	0
Spillback Cap Reductn	0	0	0	0	0
Storage Cap Reductn	0	0	0	0	0
Reduced v/c Ratio	0.41	0.22	0.20	0.40	0.50

Intersection Summary

Queues  
3: US 101 NB Off-Ramp & Shiloh Road

Existing Project Alter. C Conditions  
Timing Plan: Saturday Midday Peak

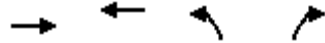

Lane Group	EBT	WBT	NBL	NBR
Lane Group Flow (vph)	445	793	371	626
v/c Ratio	0.24	0.82	0.64	0.49
Control Delay	8.6	21.7	22.0	4.0
Queue Delay	0.0	0.0	0.0	0.0
Total Delay	8.6	21.7	22.0	4.0
Queue Length 50th (ft)	38	202	114	11
Queue Length 95th (ft)	83	#503	189	44
Internal Link Dist (ft)	106	291	689	
Turn Bay Length (ft)				265
Base Capacity (vph)	2172	1143	1020	1837
Starvation Cap Reductn	0	0	0	0
Spillback Cap Reductn	0	0	0	0
Storage Cap Reductn	0	0	0	0
Reduced v/c Ratio	0.20	0.69	0.36	0.34

Intersection Summary

# 95th percentile volume exceeds capacity, queue may be longer.  
Queue shown is maximum after two cycles.

Queues  
4: Shiloh Road & US 101 SB Off-Ramp

Existing Project Alter. C Conditions  
Timing Plan: Saturday Midday Peak

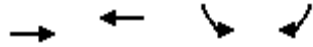

Lane Group	EBT	WBT	SBL	SBR
Lane Group Flow (vph)	284	547	310	222
v/c Ratio	0.35	0.67	0.49	0.31
Control Delay	8.8	13.7	14.5	3.6
Queue Delay	0.0	0.0	0.0	0.0
Total Delay	8.8	13.7	14.5	3.6
Queue Length 50th (ft)	39	89	52	0
Queue Length 95th (ft)	82	180	91	14
Internal Link Dist (ft)	145	226	406	
Turn Bay Length (ft)				275
Base Capacity (vph)	1863	1863	764	809
Starvation Cap Reductn	0	0	0	0
Spillback Cap Reductn	0	0	0	0
Storage Cap Reductn	0	0	0	0
Reduced v/c Ratio	0.15	0.29	0.41	0.27
Intersection Summary				



Queues  
6: Conde Lane & Shiloh Road

Existing Project Alter. C Conditions  
Timing Plan: Saturday Midday Peak

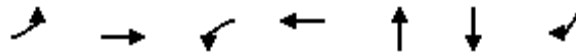

Lane Group	EBL	EBT	WBL	WBT	NBT	SBT	SBR
Lane Group Flow (vph)	30	377	10	667	12	253	36
v/c Ratio	0.07	0.28	0.02	0.51	0.02	0.45	0.06
Control Delay	18.9	10.2	19.2	10.6	0.1	20.7	10.5
Queue Delay	0.0	0.0	0.0	0.0	0.0	0.0	0.0
Total Delay	18.9	10.2	19.2	10.6	0.1	20.7	10.5
Queue Length 50th (ft)	4	20	1	33	0	32	3
Queue Length 95th (ft)	34	92	17	150	0	#183	24
Internal Link Dist (ft)		735		1001	338	442	
Turn Bay Length (ft)	90		127				40
Base Capacity (vph)	460	3264	409	3075	1461	562	1455
Starvation Cap Reductn	0	0	0	0	0	0	0
Spillback Cap Reductn	0	0	0	0	0	0	0
Storage Cap Reductn	0	0	0	0	0	0	0
Reduced v/c Ratio	0.07	0.12	0.02	0.22	0.01	0.45	0.02

Intersection Summary

# 95th percentile volume exceeds capacity, queue may be longer.  
Queue shown is maximum after two cycles.

Queues

Existing Project Alter. C Conditions

10: US 101 NB Off Ramp/Lakewood Drive & Old Redwood Highway Timing Plan: Saturday Midday Peak



Lane Group	EBL	EBT	WBT	NBL	NBT	SBL	SBR
Lane Group Flow (vph)	265	307	789	230	456	243	699
v/c Ratio	0.76	0.32	0.62	0.63	0.59	0.80	0.87
Control Delay	52.0	13.9	21.5	35.3	26.2	57.8	24.5
Queue Delay	0.0	0.0	0.0	0.0	0.0	0.0	0.0
Total Delay	52.0	13.9	21.5	35.3	26.2	57.8	24.5
Queue Length 50th (ft)	67	84	142	113	95	61	179
Queue Length 95th (ft)	#142	170	234	187	141	#134	323
Internal Link Dist (ft)		146	537		636		
Turn Bay Length (ft)	155			270		120	
Base Capacity (vph)	348	949	1263	591	1220	304	806
Starvation Cap Reductn	0	0	0	0	0	0	0
Spillback Cap Reductn	0	0	0	0	0	0	0
Storage Cap Reductn	0	0	0	0	0	0	0
Reduced v/c Ratio	0.76	0.32	0.62	0.39	0.37	0.80	0.87

Intersection Summary

# 95th percentile volume exceeds capacity, queue may be longer.  
 Queue shown is maximum after two cycles.

Queues

Existing Project Alter. C Conditions

12: US 101 SB On Ramp/US 101 SB Off Ramp & Old Redwood Highway  
 Timing Plan: Saturday Midday Peak

























Lane Group	EBT	EBR	WBL	WBT	SBL	SBT
Lane Group Flow (vph)	498	379	446	748	164	151
v/c Ratio	0.36	0.45	0.94	0.29	0.68	0.48
Control Delay	16.1	3.8	55.6	3.9	45.2	16.1
Queue Delay	0.0	0.0	0.0	0.0	0.0	0.0
Total Delay	16.1	3.8	55.6	3.9	45.2	16.1
Queue Length 50th (ft)	77	0	186	47	71	17
Queue Length 95th (ft)	114	49	#354	67	103	45
Internal Link Dist (ft)	343			451		751
Turn Bay Length (ft)			250		420	
Base Capacity (vph)	1381	837	480	2537	240	314
Starvation Cap Reductn	0	0	0	0	0	0
Spillback Cap Reductn	0	0	0	0	0	0
Storage Cap Reductn	0	0	0	0	0	0
Reduced v/c Ratio	0.36	0.45	0.93	0.29	0.68	0.48

Intersection Summary

# 95th percentile volume exceeds capacity, queue may be longer.  
 Queue shown is maximum after two cycles.

Lanes, Volumes, Timings  
1: Old Redwood Hwy & Shiloh Road

Existing Project Alter. C Conditions  
Timing Plan: A.M. PEAK

												
Lane Group	EBL	EBT	EBR	WBL	WBT	WBR	NBL	NBT	NBR	SBL	SBT	SBR
Lane Configurations												
Traffic Volume (vph)	108	160	78	22	89	16	74	122	34	20	230	169
Future Volume (vph)	108	160	78	22	89	16	74	122	34	20	230	169
Ideal Flow (vphpl)	1900	1900	1900	1900	1900	1900	1900	1900	1900	1900	1900	1900
Storage Length (ft)	375		140	0		50	200		98	130		93
Storage Lanes	1		1	0		1	1		1	1		1
Taper Length (ft)	50			25			60			93		
Lane Util. Factor	1.00	1.00	1.00	1.00	1.00	1.00	1.00	1.00	1.00	1.00	1.00	1.00
Ped Bike Factor												0.98
Frt			0.850			0.850			0.850			0.850
Flt Protected	0.950				0.990		0.950			0.950		
Satd. Flow (prot)	1770	1863	1583	0	1844	1583	1770	1863	1583	1770	1863	1583
Flt Permitted	0.950				0.990		0.950			0.950		
Satd. Flow (perm)	1770	1863	1583	0	1844	1583	1770	1863	1583	1770	1863	1549
Right Turn on Red			Yes			Yes			Yes			Yes
Satd. Flow (RTOR)			105			105			77			125
Link Speed (mph)		40			40			45			40	
Link Distance (ft)		1789			608			748			775	
Travel Time (s)		30.5			10.4			11.3			13.2	
Confl. Bikes (#/hr)												1
Peak Hour Factor	0.81	0.81	0.81	0.89	0.89	0.89	0.93	0.93	0.93	0.85	0.85	0.85
Adj. Flow (vph)	133	198	96	25	100	18	80	131	37	24	271	199
Shared Lane Traffic (%)												
Lane Group Flow (vph)	133	198	96	0	125	18	80	131	37	24	271	199
Enter Blocked Intersection	No	No	No	No	No	No	No	No	No	No	No	No
Lane Alignment	Left	Left	Right	Left	Left	Right	Left	Left	Right	Left	Left	Right
Median Width(ft)		12			12			12			12	
Link Offset(ft)		0			0			0			0	
Crosswalk Width(ft)		16			16			16			16	
Two way Left Turn Lane												
Headway Factor	1.00	1.00	1.00	1.00	1.00	1.00	1.00	1.00	1.00	1.00	1.00	1.00
Turning Speed (mph)	15		9	15		9	15		9	15		9
Number of Detectors	1	2	1	1	2	1	1	2	1	1	2	1
Detector Template	Left	Thru	Right	Left	Thru	Right	Left	Thru	Right	Left	Thru	Right
Leading Detector (ft)	20	100	20	20	100	20	20	100	20	20	100	20
Trailing Detector (ft)	0	0	0	0	0	0	0	0	0	0	0	0
Detector 1 Position(ft)	0	0	0	0	0	0	0	0	0	0	0	0
Detector 1 Size(ft)	20	6	20	20	6	20	20	6	20	20	6	20
Detector 1 Type	Cl+Ex	Cl+Ex	Cl+Ex	Cl+Ex	Cl+Ex	Cl+Ex	Cl+Ex	Cl+Ex	Cl+Ex	Cl+Ex	Cl+Ex	Cl+Ex
Detector 1 Channel												
Detector 1 Extend (s)	0.0	0.0	0.0	0.0	0.0	0.0	0.0	0.0	0.0	0.0	0.0	0.0
Detector 1 Queue (s)	0.0	0.0	0.0	0.0	0.0	0.0	0.0	0.0	0.0	0.0	0.0	0.0
Detector 1 Delay (s)	0.0	0.0	0.0	0.0	0.0	0.0	0.0	0.0	0.0	0.0	0.0	0.0
Detector 2 Position(ft)		94			94			94			94	
Detector 2 Size(ft)		6			6			6			6	
Detector 2 Type		Cl+Ex			Cl+Ex			Cl+Ex			Cl+Ex	
Detector 2 Channel												
Detector 2 Extend (s)		0.0			0.0			0.0			0.0	
Turn Type	Split	NA	Perm	Split	NA	Perm	Prot	NA	Perm	Prot	NA	Perm

Lanes, Volumes, Timings  
1: Old Redwood Hwy & Shiloh Road

Existing Project Alter. C Conditions  
Timing Plan: A.M. PEAK

Lane Group	EBL	EBT	EBR	WBL	WBT	WBR	NBL	NBT	NBR	SBL	SBT	SBR
Protected Phases	2	2		6	6		3	8		7	4	
Permitted Phases			2			6			8			4
Detector Phase	2	2	2	6	6	6	3	8	8	7	4	4
Switch Phase												
Minimum Initial (s)	5.0	5.0	5.0	5.0	5.0	5.0	5.0	5.0	5.0	5.0	5.0	5.0
Minimum Split (s)	34.5	34.5	34.5	42.5	42.5	42.5	8.5	46.5	46.5	8.5	39.5	39.5
Total Split (s)	35.0	35.0	35.0	42.5	42.5	42.5	18.0	48.0	48.0	9.5	39.5	39.5
Total Split (%)	25.9%	25.9%	25.9%	31.5%	31.5%	31.5%	13.3%	35.6%	35.6%	7.0%	29.3%	29.3%
Maximum Green (s)	30.5	30.5	30.5	38.0	38.0	38.0	14.5	43.5	43.5	6.0	35.0	35.0
Yellow Time (s)	3.5	3.5	3.5	3.5	3.5	3.5	3.0	3.5	3.5	3.0	3.5	3.5
All-Red Time (s)	1.0	1.0	1.0	1.0	1.0	1.0	0.5	1.0	1.0	0.5	1.0	1.0
Lost Time Adjust (s)	0.0	0.0	0.0		0.0	0.0	0.0	0.0	0.0	0.0	0.0	0.0
Total Lost Time (s)	4.5	4.5	4.5		4.5	4.5	3.5	4.5	4.5	3.5	4.5	4.5
Lead/Lag	Lead	Lead	Lead	Lag	Lag	Lag	Lead	Lag	Lag	Lead	Lag	Lag
Lead-Lag Optimize?	Yes	Yes	Yes	Yes	Yes	Yes	Yes	Yes	Yes	Yes	Yes	Yes
Vehicle Extension (s)	3.0	3.0	3.0	3.0	3.0	3.0	3.0	3.0	3.0	3.0	3.0	3.0
Recall Mode	None	None	None	None	None	None	None	None	None	None	None	None
Walk Time (s)	7.0	7.0	7.0	7.0	7.0	7.0		7.0	7.0		7.0	7.0
Flash Dont Walk (s)	23.0	23.0	23.0	31.0	31.0	31.0		35.0	35.0		28.0	28.0
Pedestrian Calls (#/hr)	0	0	0	0	0	0		0	0		0	0
Act Effct Green (s)	14.1	14.1	14.1		11.2	11.2	9.4	23.9	23.9	6.4	17.0	17.0
Actuated g/C Ratio	0.21	0.21	0.21		0.17	0.17	0.14	0.36	0.36	0.10	0.25	0.25
v/c Ratio	0.36	0.51	0.23		0.40	0.05	0.32	0.20	0.06	0.14	0.58	0.41
Control Delay	29.6	32.0	7.1		34.0	0.2	35.1	18.2	1.0	38.7	30.0	13.3
Queue Delay	0.0	0.0	0.0		0.0	0.0	0.0	0.0	0.0	0.0	0.0	0.0
Total Delay	29.6	32.0	7.1		34.0	0.2	35.1	18.2	1.0	38.7	30.0	13.3
LOS	C	C	A		C	A	D	B	A	D	C	B
Approach Delay		25.7			29.7			21.1			23.7	
Approach LOS		C			C			C			C	

Intersection Summary

Area Type:	Other
Cycle Length:	135
Actuated Cycle Length:	67
Natural Cycle:	135
Control Type:	Actuated-Uncoordinated
Maximum v/c Ratio:	0.58
Intersection Signal Delay:	24.5
Intersection LOS:	C
Intersection Capacity Utilization:	45.2%
ICU Level of Service:	A
Analysis Period (min):	15

Splits and Phases: 1: Old Redwood Hwy & Shiloh Road



Lanes, Volumes, Timings  
2: Shiloh Road & Hembree Ln

Existing Project Alter. C Conditions  
Timing Plan: A.M. PEAK



Lane Group	EBL	EBT	WBT	WBR	SBL	SBR
Lane Configurations						
Traffic Volume (vph)	305	294	292	68	71	361
Future Volume (vph)	305	294	292	68	71	361
Ideal Flow (vphpl)	1900	1900	1900	1900	1900	1900
Storage Length (ft)	0			130	0	0
Storage Lanes	2			1	1	1
Taper Length (ft)	25				25	
Lane Util. Factor	0.97	1.00	0.95	0.95	1.00	1.00
Frt			0.972			0.850
Flt Protected	0.950				0.950	
Satd. Flow (prot)	3433	1863	3440	0	1770	1583
Flt Permitted	0.950				0.950	
Satd. Flow (perm)	3433	1863	3440	0	1770	1583
Right Turn on Red				Yes		Yes
Satd. Flow (RTOR)			40			384
Link Speed (mph)		40	40		35	
Link Distance (ft)		302	1789		381	
Travel Time (s)		5.1	30.5		7.4	
Peak Hour Factor	0.88	0.88	0.97	0.97	0.94	0.94
Adj. Flow (vph)	347	334	301	70	76	384
Shared Lane Traffic (%)						
Lane Group Flow (vph)	347	334	371	0	76	384
Enter Blocked Intersection	No	No	No	No	No	No
Lane Alignment	Left	Left	Left	Right	Left	Right
Median Width(ft)		24	24		12	
Link Offset(ft)		0	0		0	
Crosswalk Width(ft)		16	16		16	
Two way Left Turn Lane						
Headway Factor	1.00	1.00	1.00	1.00	1.00	1.00
Turning Speed (mph)	15			9	15	9
Number of Detectors	1	2	2		1	1
Detector Template	Left	Thru	Thru		Left	Right
Leading Detector (ft)	20	100	100		20	20
Trailing Detector (ft)	0	0	0		0	0
Detector 1 Position(ft)	0	0	0		0	0
Detector 1 Size(ft)	20	6	6		20	20
Detector 1 Type	Cl+Ex	Cl+Ex	Cl+Ex		Cl+Ex	Cl+Ex
Detector 1 Channel						
Detector 1 Extend (s)	0.0	0.0	0.0		0.0	0.0
Detector 1 Queue (s)	0.0	0.0	0.0		0.0	0.0
Detector 1 Delay (s)	0.0	0.0	0.0		0.0	0.0
Detector 2 Position(ft)		94	94			
Detector 2 Size(ft)		6	6			
Detector 2 Type		Cl+Ex	Cl+Ex			
Detector 2 Channel						
Detector 2 Extend (s)		0.0	0.0			
Turn Type	Prot	NA	NA		Perm	pm+ov
Protected Phases	5	2	6			5
Permitted Phases					4	4 5

Lanes, Volumes, Timings  
2: Shiloh Road & Hembree Ln

Existing Project Alter. C Conditions  
Timing Plan: A.M. PEAK



Lane Group	EBL	EBT	WBT	WBR	SBL	SBR
Detector Phase	5	2	6		4	5
Switch Phase						
Minimum Initial (s)	3.0	5.0	5.0		5.0	3.0
Minimum Split (s)	7.0	9.0	43.0		9.0	7.0
Total Split (s)	29.0	73.0	44.0		17.0	29.0
Total Split (%)	32.2%	81.1%	48.9%		18.9%	32.2%
Maximum Green (s)	25.0	69.0	40.0		13.0	25.0
Yellow Time (s)	3.0	3.0	3.0		3.0	3.0
All-Red Time (s)	1.0	1.0	1.0		1.0	1.0
Lost Time Adjust (s)	0.0	0.0	0.0		0.0	0.0
Total Lost Time (s)	4.0	4.0	4.0		4.0	4.0
Lead/Lag	Lead		Lag		Lead	
Lead-Lag Optimize?	Yes		Yes		Yes	
Vehicle Extension (s)	3.0	3.0	3.0		3.0	3.0
Recall Mode	None	None	None		None	None
Walk Time (s)			7.0			
Flash Dont Walk (s)			32.0			
Pedestrian Calls (#/hr)			0			
Act Effct Green (s)	10.4	27.3	10.0		7.7	16.4
Actuated g/C Ratio	0.29	0.77	0.28		0.22	0.46
v/c Ratio	0.34	0.23	0.37		0.20	0.41
Control Delay	12.6	3.6	12.1		16.3	2.2
Queue Delay	0.0	0.0	0.0		0.0	0.0
Total Delay	12.6	3.6	12.1		16.3	2.2
LOS	B	A	B		B	A
Approach Delay		8.2	12.1		4.5	
Approach LOS		A	B		A	

Intersection Summary

Area Type:	Other
Cycle Length:	90
Actuated Cycle Length:	35.3
Natural Cycle:	60
Control Type:	Actuated-Uncoordinated
Maximum v/c Ratio:	0.41
Intersection Signal Delay:	8.0
Intersection LOS:	A
Intersection Capacity Utilization:	39.3%
ICU Level of Service:	A
Analysis Period (min):	15

Splits and Phases: 2: Shiloh Road & Hembree Ln



Lanes, Volumes, Timings  
3: US 101 NB Off-Ramp & Shiloh Road

Existing Project Alter. C Conditions  
Timing Plan: A.M. PEAK



Lane Group	EBT	EBR	WBL	WBT	NBL	NBR
Lane Configurations	↑↑			↑	↘	↗↗
Traffic Volume (vph)	246	0	0	515	432	366
Future Volume (vph)	246	0	0	515	432	366
Ideal Flow (vphpl)	1900	1900	1900	1900	1900	1900
Storage Length (ft)		0	0		0	265
Storage Lanes		0	0		1	2
Taper Length (ft)			25		25	
Lane Util. Factor	0.95	1.00	1.00	1.00	1.00	0.88
Frt						0.850
Flt Protected					0.950	
Satd. Flow (prot)	3539	0	0	1863	1770	2787
Flt Permitted					0.950	
Satd. Flow (perm)	3539	0	0	1863	1770	2787
Right Turn on Red		Yes				Yes
Satd. Flow (RTOR)						482
Link Speed (mph)	40			40	30	
Link Distance (ft)	186			371	769	
Travel Time (s)	3.2			6.3	17.5	
Peak Hour Factor	0.91	0.91	0.90	0.90	0.76	0.76
Adj. Flow (vph)	270	0	0	572	568	482
Shared Lane Traffic (%)						
Lane Group Flow (vph)	270	0	0	572	568	482
Enter Blocked Intersection	No	No	No	No	No	No
Lane Alignment	Left	Right	Left	Left	Left	Right
Median Width(ft)	0			0	12	
Link Offset(ft)	0			0	0	
Crosswalk Width(ft)	16			16	16	
Two way Left Turn Lane						
Headway Factor	1.00	1.00	1.00	1.00	1.00	1.00
Turning Speed (mph)		9	15		15	9
Number of Detectors	2			2	1	1
Detector Template	Thru			Thru	Left	Right
Leading Detector (ft)	100			100	20	20
Trailing Detector (ft)	0			0	0	0
Detector 1 Position(ft)	0			0	0	0
Detector 1 Size(ft)	6			6	20	20
Detector 1 Type	Cl+Ex			Cl+Ex	Cl+Ex	Cl+Ex
Detector 1 Channel						
Detector 1 Extend (s)	0.0			0.0	0.0	0.0
Detector 1 Queue (s)	0.0			0.0	0.0	0.0
Detector 1 Delay (s)	0.0			0.0	0.0	0.0
Detector 2 Position(ft)	94			94		
Detector 2 Size(ft)	6			6		
Detector 2 Type	Cl+Ex			Cl+Ex		
Detector 2 Channel						
Detector 2 Extend (s)	0.0			0.0		
Turn Type	NA			NA	Prot	Perm
Protected Phases	2			6	8	
Permitted Phases						8



Lanes, Volumes, Timings  
 3: US 101 NB Off-Ramp & Shiloh Road

Existing Project Alter. C Conditions  
 Timing Plan: A.M. PEAK



Lane Group	EBT	EBR	WBL	WBT	NBL	NBR
Detector Phase	2			6	8	8
Switch Phase						
Minimum Initial (s)	5.0			5.0	5.0	5.0
Minimum Split (s)	9.0			9.0	9.0	9.0
Total Split (s)	37.0			37.0	35.0	35.0
Total Split (%)	51.4%			51.4%	48.6%	48.6%
Maximum Green (s)	33.0			33.0	31.0	31.0
Yellow Time (s)	3.0			3.0	3.0	3.0
All-Red Time (s)	1.0			1.0	1.0	1.0
Lost Time Adjust (s)	0.0			0.0	0.0	0.0
Total Lost Time (s)	4.0			4.0	4.0	4.0
Lead/Lag						
Lead-Lag Optimize?						
Vehicle Extension (s)	3.0			3.0	3.0	3.0
Recall Mode	None			None	None	None
Act Effect Green (s)	22.5			22.5	23.0	23.0
Actuated g/C Ratio	0.41			0.41	0.42	0.42
v/c Ratio	0.18			0.74	0.76	0.33
Control Delay	11.1			21.0	22.2	2.1
Queue Delay	0.0			0.0	0.0	0.0
Total Delay	11.1			21.0	22.2	2.1
LOS	B			C	C	A
Approach Delay	11.1			21.0	13.0	
Approach LOS	B			C	B	

Intersection Summary

Area Type: Other  
 Cycle Length: 72  
 Actuated Cycle Length: 54.3  
 Natural Cycle: 50  
 Control Type: Actuated-Uncoordinated  
 Maximum v/c Ratio: 0.76  
 Intersection Signal Delay: 15.1  
 Intersection LOS: B  
 Intersection Capacity Utilization 80.4%  
 ICU Level of Service D  
 Analysis Period (min) 15

Splits and Phases: 3: US 101 NB Off-Ramp & Shiloh Road

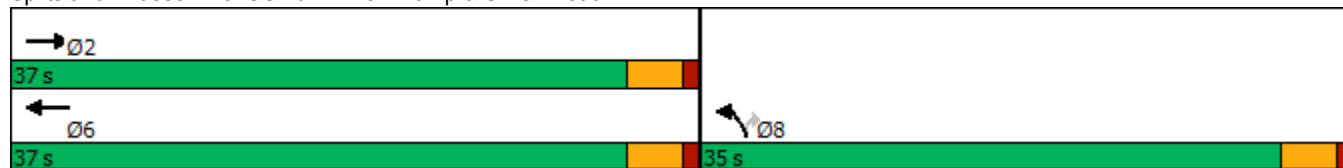

Lanes, Volumes, Timings  
4: Shiloh Road & US 101 SB Off-Ramp

Existing Project Alter. C Conditions  
Timing Plan: A.M. PEAK



Lane Group	EBL	EBT	WBT	WBR	SBL	SBR
Lane Configurations		↑	↑		↘	↗
Traffic Volume (vph)	0	231	587	0	103	138
Future Volume (vph)	0	231	587	0	103	138
Ideal Flow (vphpl)	1900	1900	1900	1900	1900	1900
Storage Length (ft)	0			0	0	275
Storage Lanes	0			0	1	1
Taper Length (ft)	25				25	
Lane Util. Factor	1.00	1.00	1.00	1.00	1.00	1.00
Frt						0.850
Flt Protected					0.950	
Satd. Flow (prot)	0	1863	1863	0	1770	1583
Flt Permitted					0.950	
Satd. Flow (perm)	0	1863	1863	0	1770	1583
Right Turn on Red				Yes		Yes
Satd. Flow (RTOR)						150
Link Speed (mph)		40	40		30	
Link Distance (ft)		225	306		486	
Travel Time (s)		3.8	5.2		11.0	
Peak Hour Factor	0.93	0.93	0.91	0.91	0.92	0.92
Adj. Flow (vph)	0	248	645	0	112	150
Shared Lane Traffic (%)						
Lane Group Flow (vph)	0	248	645	0	112	150
Enter Blocked Intersection	No	No	No	No	No	No
Lane Alignment	Left	Left	Left	Right	Left	Right
Median Width(ft)		4	0		12	
Link Offset(ft)		0	0		0	
Crosswalk Width(ft)		16	16		16	
Two way Left Turn Lane						
Headway Factor	1.00	1.00	1.00	1.00	1.00	1.00
Turning Speed (mph)	15			9	15	9
Number of Detectors		2	2		1	1
Detector Template		Thru	Thru		Left	Right
Leading Detector (ft)		100	100		20	20
Trailing Detector (ft)		0	0		0	0
Detector 1 Position(ft)		0	0		0	0
Detector 1 Size(ft)		6	6		20	20
Detector 1 Type		Cl+Ex	Cl+Ex		Cl+Ex	Cl+Ex
Detector 1 Channel						
Detector 1 Extend (s)		0.0	0.0		0.0	0.0
Detector 1 Queue (s)		0.0	0.0		0.0	0.0
Detector 1 Delay (s)		0.0	0.0		0.0	0.0
Detector 2 Position(ft)		94	94			
Detector 2 Size(ft)		6	6			
Detector 2 Type		Cl+Ex	Cl+Ex			
Detector 2 Channel						
Detector 2 Extend (s)		0.0	0.0			
Turn Type		NA	NA		Perm	Perm
Protected Phases		2	6			
Permitted Phases					4	4

Lanes, Volumes, Timings  
4: Shiloh Road & US 101 SB Off-Ramp

Existing Project Alter. C Conditions  
Timing Plan: A.M. PEAK

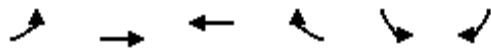

Lane Group	EBL	EBT	WBT	WBR	SBL	SBR
Detector Phase		2	6		4	4
Switch Phase						
Minimum Initial (s)		5.0	5.0		5.0	5.0
Minimum Split (s)		9.0	38.0		9.0	9.0
Total Split (s)		69.0	69.0		21.0	21.0
Total Split (%)		76.7%	76.7%		23.3%	23.3%
Maximum Green (s)		65.0	65.0		17.0	17.0
Yellow Time (s)		3.0	3.0		3.0	3.0
All-Red Time (s)		1.0	1.0		1.0	1.0
Lost Time Adjust (s)		0.0	0.0		0.0	0.0
Total Lost Time (s)		4.0	4.0		4.0	4.0
Lead/Lag						
Lead-Lag Optimize?						
Vehicle Extension (s)		3.0	3.0		3.0	3.0
Recall Mode		None	None		None	None
Walk Time (s)			7.0			
Flash Dont Walk (s)			27.0			
Pedestrian Calls (#/hr)			0			
Act Effct Green (s)		21.0	21.0		8.5	8.5
Actuated g/C Ratio		0.64	0.64		0.26	0.26
v/c Ratio		0.21	0.54		0.24	0.29
Control Delay		4.6	7.3		14.7	5.3
Queue Delay		0.0	0.0		0.0	0.0
Total Delay		4.6	7.3		14.7	5.3
LOS		A	A		B	A
Approach Delay		4.6	7.3		9.3	
Approach LOS		A	A		A	

Intersection Summary

Area Type:	Other
Cycle Length:	90
Actuated Cycle Length:	32.8
Natural Cycle:	50
Control Type:	Actuated-Uncoordinated
Maximum v/c Ratio:	0.54
Intersection Signal Delay:	7.2
Intersection LOS:	A
Intersection Capacity Utilization:	56.1%
ICU Level of Service:	B
Analysis Period (min):	15

Splits and Phases: 4: Shiloh Road & US 101 SB Off-Ramp



Lanes, Volumes, Timings  
5: Caletti Ave & Shiloh Road

Existing Project Alter. C Conditions  
Timing Plan: A.M. PEAK



Lane Group	EBT	EBR	WBL	WBT	NBL	NBR
Lane Configurations	↑↑		↵	↑	↵	↵
Traffic Volume (vph)	523	22	177	550	7	121
Future Volume (vph)	523	22	177	550	7	121
Ideal Flow (vphpl)	1900	1900	1900	1900	1900	1900
Storage Length (ft)		0	68		0	0
Storage Lanes		0	1		1	1
Taper Length (ft)			50		25	
Lane Util. Factor	0.95	0.95	1.00	1.00	1.00	1.00
Frt	0.994					0.850
Flt Protected			0.950		0.950	
Satd. Flow (prot)	3518	0	1770	1863	1770	1583
Flt Permitted			0.950		0.950	
Satd. Flow (perm)	3518	0	1770	1863	1770	1583
Link Speed (mph)	40			40	30	
Link Distance (ft)	1081			184	459	
Travel Time (s)	18.4			3.1	10.4	
Peak Hour Factor	0.96	0.96	0.87	0.87	0.84	0.84
Adj. Flow (vph)	545	23	203	632	8	144
Shared Lane Traffic (%)						
Lane Group Flow (vph)	568	0	203	632	8	144
Enter Blocked Intersection	No	No	No	No	No	No
Lane Alignment	Left	Right	Left	Left	Left	Right
Median Width(ft)	12			12	12	
Link Offset(ft)	0			0	0	
Crosswalk Width(ft)	16			16	16	
Two way Left Turn Lane						
Headway Factor	1.00	1.00	1.00	1.00	1.00	1.00
Turning Speed (mph)		9	15		15	9
Sign Control	Free			Free	Stop	

Intersection Summary

Area Type:	Other
Control Type:	Unsignalized
Intersection Capacity Utilization	38.9%
ICU Level of Service	A
Analysis Period (min)	15

Lanes, Volumes, Timings  
6: Conde Lane & Shiloh Road

Existing Project Alter. C Conditions  
Timing Plan: A.M. PEAK



Lane Group	EBL	EBT	EBR	WBL	WBT	WBR	NBL	NBT	NBR	SBL	SBT	SBR
Lane Configurations												
Traffic Volume (vph)	25	328	5	9	354	204	4	0	12	205	1	35
Future Volume (vph)	25	328	5	9	354	204	4	0	12	205	1	35
Ideal Flow (vphpl)	1900	1900	1900	1900	1900	1900	1900	1900	1900	1900	1900	1900
Storage Length (ft)	90		0	127		0	0		0	0		40
Storage Lanes	1		0	1		0	0		0	0		1
Taper Length (ft)	70			40			25			25		
Lane Util. Factor	1.00	0.95	0.95	1.00	0.95	0.95	1.00	1.00	1.00	1.00	1.00	1.00
Frt		0.998			0.945			0.899				0.850
Flt Protected	0.950			0.950				0.988			0.953	
Satd. Flow (prot)	1770	3532	0	1770	3345	0	0	1655	0	0	1775	1583
Flt Permitted	0.950			0.950				0.988			0.953	
Satd. Flow (perm)	1770	3532	0	1770	3345	0	0	1655	0	0	1775	1583
Right Turn on Red			Yes			Yes			Yes			No
Satd. Flow (RTOR)		1			119			89				
Link Speed (mph)		40			40			30				35
Link Distance (ft)		815			1081			418				522
Travel Time (s)		13.9			18.4			9.5				10.2
Peak Hour Factor	0.95	0.95	0.95	0.85	0.85	0.85	0.57	0.57	0.57	0.86	0.86	0.86
Adj. Flow (vph)	26	345	5	11	416	240	7	0	21	238	1	41
Shared Lane Traffic (%)												
Lane Group Flow (vph)	26	350	0	11	656	0	0	28	0	0	239	41
Enter Blocked Intersection	No	No	No	No	No	No	No	No	No	No	No	No
Lane Alignment	Left	Left	Right	Left	Left	Right	Left	Left	Right	Left	Left	Right
Median Width(ft)		12			12			0				0
Link Offset(ft)		0			0			0				0
Crosswalk Width(ft)		16			16			16				16
Two way Left Turn Lane												
Headway Factor	1.00	1.00	1.00	1.00	1.00	1.00	1.00	1.00	1.00	1.00	1.00	1.00
Turning Speed (mph)	15		9	15		9	15		9	15		9
Number of Detectors	1	2		1	2		1	2		1	1	1
Detector Template	Left	Thru		Left	Thru		Left	Thru		Left	Thru	Right
Leading Detector (ft)	20	100		20	100		20	100		20	30	20
Trailing Detector (ft)	0	0		0	0		0	0		0	0	0
Detector 1 Position(ft)	0	0		0	0		0	0		0	0	0
Detector 1 Size(ft)	20	6		20	6		20	6		20	30	20
Detector 1 Type	Cl+Ex	Cl+Ex		Cl+Ex	Cl+Ex		Cl+Ex	Cl+Ex		Cl+Ex	Cl+Ex	Cl+Ex
Detector 1 Channel												
Detector 1 Extend (s)	0.0	0.0		0.0	0.0		0.0	0.0		0.0	0.0	0.0
Detector 1 Queue (s)	0.0	0.0		0.0	0.0		0.0	0.0		0.0	0.0	0.0
Detector 1 Delay (s)	0.0	0.0		0.0	0.0		0.0	0.0		0.0	0.0	0.0
Detector 2 Position(ft)		94			94			94				
Detector 2 Size(ft)		6			6			6				
Detector 2 Type		Cl+Ex			Cl+Ex			Cl+Ex				
Detector 2 Channel												
Detector 2 Extend (s)		0.0			0.0			0.0				
Turn Type	Prot	NA		Prot	NA		Split	NA		Split	NA	custom
Protected Phases	5	2		1	6		7	7		4	4	
Permitted Phases												6

Lanes, Volumes, Timings  
6: Conde Lane & Shiloh Road

Existing Project Alter. C Conditions  
Timing Plan: A.M. PEAK

Lane Group	EBL	EBT	EBR	WBL	WBT	WBR	NBL	NBT	NBR	SBL	SBT	SBR
Detector Phase	5	2		1	6		7	7		4	4	6
Switch Phase												
Minimum Initial (s)	8.0	8.0		8.0	8.0		10.0	10.0		11.0	11.0	8.0
Minimum Split (s)	12.0	46.0		12.0	12.0		37.0	37.0		15.0	15.0	12.0
Total Split (s)	13.0	46.0		12.0	45.0		37.0	37.0		15.0	15.0	45.0
Total Split (%)	11.8%	41.8%		10.9%	40.9%		33.6%	33.6%		13.6%	13.6%	40.9%
Maximum Green (s)	9.0	42.0		8.0	41.0		33.0	33.0		11.0	11.0	41.0
Yellow Time (s)	3.0	3.0		3.0	3.0		3.0	3.0		3.0	3.0	3.0
All-Red Time (s)	1.0	1.0		1.0	1.0		1.0	1.0		1.0	1.0	1.0
Lost Time Adjust (s)	0.0	0.0		0.0	0.0		0.0	0.0		0.0	0.0	0.0
Total Lost Time (s)	4.0	4.0		4.0	4.0		4.0	4.0		4.0	4.0	4.0
Lead/Lag	Lead	Lag		Lead	Lag							Lag
Lead-Lag Optimize?	Yes	Yes		Yes	Yes							Yes
Vehicle Extension (s)	3.0	3.0		3.0	3.0		3.0	3.0		3.0	3.0	3.0
Recall Mode	None	None		None	None		None	None		None	None	None
Walk Time (s)		7.0					7.0	7.0				
Flash Dont Walk (s)		35.0					26.0	26.0				
Pedestrian Calls (#/hr)		0					0	0				
Act Effct Green (s)	9.3	16.4		9.3	14.7			11.7			12.9	14.7
Actuated g/C Ratio	0.21	0.37		0.21	0.33			0.27			0.29	0.33
v/c Ratio	0.07	0.27		0.03	0.55			0.06			0.46	0.08
Control Delay	23.6	11.2		23.8	13.1			0.2			24.8	14.1
Queue Delay	0.0	0.0		0.0	0.0			0.0			0.0	0.0
Total Delay	23.6	11.2		23.8	13.1			0.2			24.8	14.1
LOS	C	B		C	B			A			C	B
Approach Delay		12.1			13.3			0.2			23.2	
Approach LOS		B			B			A			C	

Intersection Summary





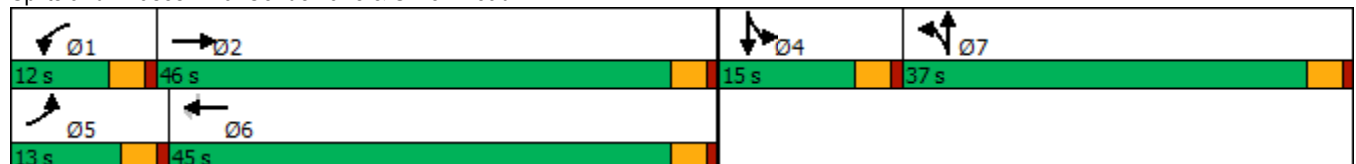











Area Type:	Other
Cycle Length:	110
Actuated Cycle Length:	43.9
Natural Cycle:	110
Control Type:	Actuated-Uncoordinated
Maximum v/c Ratio:	0.55
Intersection Signal Delay:	14.8
Intersection LOS:	B
Intersection Capacity Utilization:	45.5%
ICU Level of Service:	A
Analysis Period (min):	15

Splits and Phases: 6: Conde Lane & Shiloh Road



Lanes, Volumes, Timings  
7: Entrance 1/Gridley Drive & Shiloh Road



















Existing Project Alter. C Conditions  
Timing Plan: A.M. PEAK

												
Lane Group	EBL	EBT	EBR	WBL	WBT	WBR	NBL	NBT	NBR	SBL	SBT	SBR
Lane Configurations												
Traffic Volume (vph)	8	141	64	5	58	0	42	0	3	1	0	16
Future Volume (vph)	8	141	64	5	58	0	42	0	3	1	0	16
Ideal Flow (vphpl)	1900	1900	1900	1900	1900	1900	1900	1900	1900	1900	1900	1900
Lane Util. Factor	1.00	1.00	1.00	1.00	1.00	1.00	1.00	1.00	1.00	1.00	1.00	1.00
Ped Bike Factor												
Frt	0.960						0.850				0.871	
Flt Protected	0.998				0.996		0.950				0.998	
Satd. Flow (prot)	0	1785	0	0	1855	0	1770	1583	0	0	1619	0
Flt Permitted	0.998				0.996		0.950				0.998	
Satd. Flow (perm)	0	1785	0	0	1855	0	1770	1583	0	0	1619	0
Link Speed (mph)	40				40		30				30	
Link Distance (ft)	608				2146		248				715	
Travel Time (s)	10.4				36.6		5.6				16.3	
Confl. Bikes (#/hr)			1									
Peak Hour Factor	0.91	0.91	0.91	0.85	0.85	0.85	1.00	1.00	1.00	0.71	0.71	0.71
Adj. Flow (vph)	9	155	70	6	68	0	42	0	3	1	0	23
Shared Lane Traffic (%)												
Lane Group Flow (vph)	0	234	0	0	74	0	42	3	0	0	24	0
Enter Blocked Intersection	No	No	No	No	No	No	No	No	No	No	No	No
Lane Alignment	Left	Left	Right	Left	Left	Right	Left	Left	Right	Left	Left	Right
Median Width(ft)	0				0		12				12	
Link Offset(ft)	0				0		0				0	
Crosswalk Width(ft)	16				16		16				16	
Two way Left Turn Lane												
Headway Factor	1.00	1.00	1.00	1.00	1.00	1.00	1.00	1.00	1.00	1.00	1.00	1.00
Turning Speed (mph)	15		9	15		9	15		9	15		9
Sign Control	Free				Free		Stop				Stop	

Intersection Summary	
Area Type:	Other
Control Type:	Unsignalized
Intersection Capacity Utilization	29.0%
Analysis Period (min)	15
	ICU Level of Service A

Lanes, Volumes, Timings  
8: Old Redwood Hwy & Entrance 1

Existing Project Alter. C Conditions  
Timing Plan: A.M. PEAK











												
Lane Group	EBL	EBT	EBR	WBL	WBT	WBR	NBL	NBT	NBR	SBL	SBT	SBR
Lane Configurations												
Traffic Volume (vph)	1	0	0	6	0	10	0	217	9	15	316	0
Future Volume (vph)	1	0	0	6	0	10	0	217	9	15	316	0
Ideal Flow (vphp)	1900	1900	1900	1900	1900	1900	1900	1900	1900	1900	1900	1900
Storage Length (ft)	0		0	0		0	0		0	50		0
Storage Lanes	0		0	1		0	0		0	1		0
Taper Length (ft)	25			25			25			25		
Lane Util. Factor	1.00	1.00	1.00	1.00	1.00	1.00	1.00	1.00	1.00	1.00	1.00	1.00
Ped Bike Factor												
Frt					0.850			0.995				
Flt Protected		0.950		0.950						0.950		
Satd. Flow (prot)	0	1770	0	1770	1583	0	0	1853	0	1770	1863	0
Flt Permitted		0.950		0.950						0.950		
Satd. Flow (perm)	0	1770	0	1770	1583	0	0	1853	0	1770	1863	0
Link Speed (mph)		30			30			45			45	
Link Distance (ft)		98			385			520			748	
Travel Time (s)		2.2			8.8			7.9			11.3	
Confl. Peds. (#/hr)									1	1		
Confl. Bikes (#/hr)									1			2
Peak Hour Factor	0.25	0.25	0.25	1.00	1.00	1.00	0.99	0.99	0.99	0.90	0.90	0.90
Adj. Flow (vph)	4	0	0	6	0	10	0	219	9	17	351	0
Shared Lane Traffic (%)												
Lane Group Flow (vph)	0	4	0	6	10	0	0	228	0	17	351	0
Enter Blocked Intersection	No	No	No	No	No	No	No	No	No	No	No	No
Lane Alignment	Left	Left	Right	Left	Left	Right	Left	Left	Right	Left	Left	Right
Median Width(ft)		12			12			12			12	
Link Offset(ft)		0			0			0			0	
Crosswalk Width(ft)		16			16			16			16	
Two way Left Turn Lane												
Headway Factor	1.00	1.00	1.00	1.00	1.00	1.00	1.00	1.00	1.00	1.00	1.00	1.00
Turning Speed (mph)	15		9	15		9	15		9	15		9
Sign Control		Stop			Stop			Free			Free	

Intersection Summary	
Area Type:	Other
Control Type:	Unsignalized
Intersection Capacity Utilization	26.6%
Analysis Period (min)	15
	ICU Level of Service A



Lanes, Volumes, Timings  
9: Entrance 2 & Shiloh Road

Existing Project Alter. C Conditions  
Timing Plan: A.M. PEAK

						
Lane Group	EBT	EBR	WBL	WBT	NBL	NBR
Lane Configurations						
Traffic Volume (vph)	143	0	0	57	0	0
Future Volume (vph)	143	0	0	57	0	0
Ideal Flow (vphp)	1900	1900	1900	1900	1900	1900
Lane Util. Factor	1.00	1.00	1.00	1.00	1.00	1.00
Frt						
Flt Protected						
Satd. Flow (prot)	1863	0	0	1863	1863	1863
Flt Permitted						
Satd. Flow (perm)	1863	0	0	1863	1863	1863
Link Speed (mph)	40			40	30	
Link Distance (ft)	2146			134	402	
Travel Time (s)	36.6			2.3	9.1	
Peak Hour Factor	0.85	0.85	0.81	0.81	1.00	1.00
Adj. Flow (vph)	168	0	0	70	0	0
Shared Lane Traffic (%)						
Lane Group Flow (vph)	168	0	0	70	0	0
Enter Blocked Intersection	No	No	No	No	No	No
Lane Alignment	Left	Right	Left	Left	Left	Right
Median Width(ft)	0			0	12	
Link Offset(ft)	0			0	0	
Crosswalk Width(ft)	16			16	16	
Two way Left Turn Lane						
Headway Factor	1.00	1.00	1.00	1.00	1.00	1.00
Turning Speed (mph)		9	15		15	9
Sign Control	Free			Free	Stop	
Intersection Summary						
Area Type:	Other					
Control Type:	Unsignalized					
Intersection Capacity Utilization	10.9%			ICU Level of Service A		
Analysis Period (min)	15					

Lanes, Volumes, Timings

Existing Project Alter. C Conditions

10: US 101 NB Off Ramp/Lakewood Drive & Old Redwood Highway

Timing Plan: A.M. PEAK

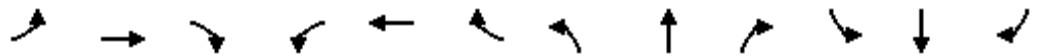

Lane Group	EBL	EBT	EBR	WBL	WBT	WBR	NBL	NBT	NBR	SBL	SBT	SBR
Lane Configurations												
Traffic Volume (vph)	152	158	0	0	446	149	227	221	79	118	0	534
Future Volume (vph)	152	158	0	0	446	149	227	221	79	118	0	534
Ideal Flow (vphpl)	1900	1900	1900	1900	1900	1900	1900	1900	1900	1900	1900	1900
Storage Length (ft)	155		0	0		0	270		150	120		0
Storage Lanes	1		0	0		0	1		1	1		1
Taper Length (ft)	50			25			165			75		
Lane Util. Factor	0.97	1.00	1.00	1.00	0.95	0.95	0.91	0.91	0.95	0.97	1.00	1.00
Ped Bike Factor	1.00				1.00			1.00		1.00		
Flt					0.962			0.966				0.850
Flt Protected	0.950						0.950	0.993		0.950		
Satd. Flow (prot)	3433	1863	0	0	3393	0	1610	3242	0	3433	0	1583
Flt Permitted	0.950						0.950	0.993		0.950		
Satd. Flow (perm)	3431	1863	0	0	3393	0	1610	3242	0	3427	0	1583
Right Turn on Red			Yes			Yes			Yes			Yes
Satd. Flow (RTOR)					52			41				305
Link Speed (mph)		35			35			30				30
Link Distance (ft)		226			617			716				478
Travel Time (s)		4.4			12.0			16.3				10.9
Confl. Peds. (#/hr)	1		1	1		1			2	2		
Confl. Bikes (#/hr)			1			1						
Peak Hour Factor	0.85	0.85	0.85	0.83	0.83	0.83	0.90	0.90	0.90	0.89	0.89	0.89
Adj. Flow (vph)	179	186	0	0	537	180	252	246	88	133	0	600
Shared Lane Traffic (%)							23%					
Lane Group Flow (vph)	179	186	0	0	717	0	194	392	0	133	0	600
Enter Blocked Intersection	No	No	No	No	No	No	No	No	No	No	No	No
Lane Alignment	Left	Left	Right	Left	Left	Right	Left	Left	Right	Left	Left	Right
Median Width(ft)		24			24			24				24
Link Offset(ft)		0			0			0				0
Crosswalk Width(ft)		16			16			16				16
Two way Left Turn Lane												
Headway Factor	1.00	1.00	1.00	1.00	1.00	1.00	1.00	1.00	1.00	1.00	1.00	1.00
Turning Speed (mph)	15		9	15		9	15		9	15		9
Number of Detectors	1	2			2		1	2		1		1
Detector Template	Left	Thru			Thru		Left	Thru		Left		Right
Leading Detector (ft)	20	100			100		20	100		20		20
Trailing Detector (ft)	0	0			0		0	0		0		0
Detector 1 Position(ft)	0	0			0		0	0		0		0
Detector 1 Size(ft)	20	6			6		20	6		20		20
Detector 1 Type	Cl+Ex	Cl+Ex			Cl+Ex		Cl+Ex	Cl+Ex		Cl+Ex		Cl+Ex
Detector 1 Channel												
Detector 1 Extend (s)	0.0	0.0			0.0		0.0	0.0		0.0		0.0
Detector 1 Queue (s)	0.0	0.0			0.0		0.0	0.0		0.0		0.0
Detector 1 Delay (s)	0.0	0.0			0.0		0.0	0.0		0.0		0.0
Detector 2 Position(ft)		94			94			94				
Detector 2 Size(ft)		6			6			6				
Detector 2 Type		Cl+Ex			Cl+Ex			Cl+Ex				
Detector 2 Channel												
Detector 2 Extend (s)		0.0			0.0			0.0				

Lanes, Volumes, Timings

Existing Project Alter. C Conditions

10: US 101 NB Off Ramp/Lakewood Drive & Old Redwood Highway

Timing Plan: A.M. PEAK



Lane Group	EBL	EBT	EBR	WBL	WBT	WBR	NBL	NBT	NBR	SBL	SBT	SBR
Turn Type	Prot	NA			NA		Split	NA		Prot		pm+ov
Protected Phases	5	2			6		8	8		7		5
Permitted Phases												5 8
Detector Phase	5	2			6		8	8		7		5
Switch Phase												
Minimum Initial (s)	7.0	10.0			10.0		10.0	10.0		7.0		7.0
Minimum Split (s)	11.0	32.1			32.1		33.7	33.7		11.0		11.0
Total Split (s)	13.0	45.3			32.3		33.7	33.7		11.0		13.0
Total Split (%)	14.4%	50.3%			35.9%		37.4%	37.4%		12.2%		14.4%
Maximum Green (s)	9.0	40.2			27.2		29.0	29.0		7.0		9.0
Yellow Time (s)	3.0	4.1			4.1		3.7	3.7		3.0		3.0
All-Red Time (s)	1.0	1.0			1.0		1.0	1.0		1.0		1.0
Lost Time Adjust (s)	0.0	0.0			0.0		0.0	0.0		0.0		0.0
Total Lost Time (s)	4.0	5.1			5.1		4.7	4.7		4.0		4.0
Lead/Lag	Lead				Lag		Lag	Lag		Lead		Lead
Lead-Lag Optimize?	Yes				Yes		Yes	Yes		Yes		Yes
Vehicle Extension (s)	3.0	3.0			3.0		3.0	3.0		3.0		3.0
Recall Mode	None	Max			Max		None	None		None		None
Walk Time (s)		7.0			7.0		7.0	7.0				
Flash Dont Walk (s)		20.0			17.0		22.0	22.0				
Pedestrian Calls (#/hr)		0			0		0	0				
Act Effct Green (s)	8.4	40.3			27.9		15.8	15.8		7.0		28.9
Actuated g/C Ratio	0.11	0.52			0.36		0.21	0.21		0.09		0.38
v/c Ratio	0.48	0.19			0.57		0.59	0.56		0.42		0.76
Control Delay	37.6	11.4			21.3		35.0	27.4		38.9		16.8
Queue Delay	0.0	0.0			0.0		0.0	0.0		0.0		0.0
Total Delay	37.6	11.4			21.3		35.0	27.4		38.9		16.8
LOS	D	B			C		D	C		D		B
Approach Delay		24.3			21.3			29.9				20.8
Approach LOS		C			C			C				C

Intersection Summary

Area Type:	Other
Cycle Length:	90
Actuated Cycle Length:	77
Natural Cycle:	90
Control Type:	Actuated-Uncoordinated
Maximum v/c Ratio:	0.76
Intersection Signal Delay:	23.7
Intersection LOS:	C
Intersection Capacity Utilization:	75.7%
ICU Level of Service:	D
Analysis Period (min):	15

Splits and Phases: 10: US 101 NB Off Ramp/Lakewood Drive & Old Redwood Highway

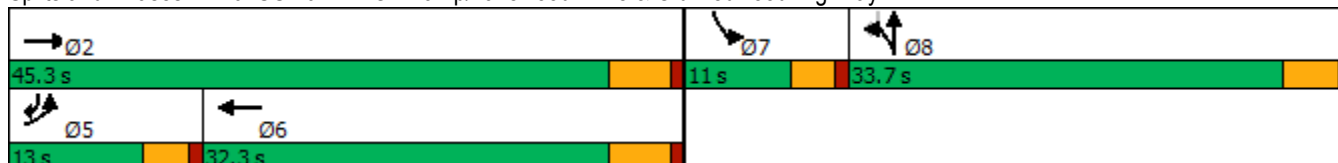

Lanes, Volumes, Timings  
 11: Old Redwood Highway & US 101 NB On Ramp

Existing Project Alter. C Conditions  
 Timing Plan: A.M. PEAK

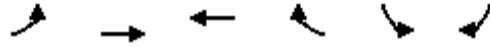

Lane Group	EBL	EBT	WBT	WBR	SBL	SBR
Lane Configurations	↶	↕↕	↶↕			
Traffic Volume (vph)	86	308	1012	190	0	0
Future Volume (vph)	86	308	1012	190	0	0
Ideal Flow (vphpl)	1900	1900	1900	1900	1900	1900
Storage Length (ft)	245			0	0	0
Storage Lanes	1			0	0	0
Taper Length (ft)	50				25	
Lane Util. Factor	1.00	0.95	0.95	0.95	1.00	1.00
Ped Bike Factor						
Frt			0.976			
Flt Protected	0.950					
Satd. Flow (prot)	1770	3539	3454	0	0	0
Flt Permitted	0.950					
Satd. Flow (perm)	1770	3539	3454	0	0	0
Link Speed (mph)		35	35		30	
Link Distance (ft)		531	226		299	
Travel Time (s)		10.3	4.4		6.8	
Confl. Peds. (#/hr)	9					
Confl. Bikes (#/hr)				1		
Peak Hour Factor	0.81	0.81	0.89	0.89	0.25	0.25
Adj. Flow (vph)	106	380	1137	213	0	0
Shared Lane Traffic (%)						
Lane Group Flow (vph)	106	380	1350	0	0	0
Enter Blocked Intersection	No	No	No	No	No	No
Lane Alignment	Left	Left	Left	Right	Left	Right
Median Width(ft)		12	12		0	
Link Offset(ft)		0	0		0	
Crosswalk Width(ft)		16	16		16	
Two way Left Turn Lane						
Headway Factor	1.00	1.00	1.00	1.00	1.00	1.00
Turning Speed (mph)	15			9	15	9
Sign Control		Free	Free		Free	

Intersection Summary	
Area Type:	Other
Control Type:	Unsignalized
Intersection Capacity Utilization	70.8%
Analysis Period (min)	15
	ICU Level of Service C

Lanes, Volumes, Timings

Existing Project Alter. C Conditions

12: US 101 SB On Ramp/US 101 SB Off Ramp & Old Redwood Highway

Timing Plan: A.M. PEAK



Lane Group	EBL	EBT	EBR	WBL	WBT	WBR	NBL	NBT	NBR	SBL	SBT	SBR
Lane Configurations		↑↑	↗	↖	↑↑					↖	↕	
Traffic Volume (vph)	0	298	296	513	504	0	0	0	0	101	1	65
Future Volume (vph)	0	298	296	513	504	0	0	0	0	101	1	65
Ideal Flow (vphpl)	1900	1900	1900	1900	1900	1900	1900	1900	1900	1900	1900	1900
Storage Length (ft)	0		0	250		0	0		0	420		0
Storage Lanes	0		1	0		0	0		0	1		0
Taper Length (ft)	25			165			25			75		
Lane Util. Factor	1.00	0.95	1.00	1.00	0.95	1.00	1.00	1.00	1.00	0.95	0.95	1.00
Ped Bike Factor			0.98	1.00								
Frt			0.850								0.879	
Flt Protected				0.950						0.950	0.991	
Satd. Flow (prot)	0	3539	1583	1770	3539	0	0	0	0	1681	1541	0
Flt Permitted				0.950						0.950	0.991	
Satd. Flow (perm)	0	3539	1558	1767	3539	0	0	0	0	1681	1541	0
Right Turn on Red			Yes			Yes			Yes			Yes
Satd. Flow (RTOR)			322								80	
Link Speed (mph)		35			35			30			30	
Link Distance (ft)		423			531			621			831	
Travel Time (s)		8.2			10.3			14.1			18.9	
Confl. Peds. (#/hr)	10		3	3		10						
Confl. Bikes (#/hr)			2									
Peak Hour Factor	0.92	0.92	0.92	0.89	0.89	0.89	0.25	0.25	0.25	0.81	0.81	0.81
Adj. Flow (vph)	0	324	322	576	566	0	0	0	0	125	1	80
Shared Lane Traffic (%)										14%		
Lane Group Flow (vph)	0	324	322	576	566	0	0	0	0	107	99	0
Enter Blocked Intersection	No	No	No	No	No	No	No	No	No	No	No	No
Lane Alignment	Left	Left	Right	Left	Left	Right	Left	Left	Right	Left	Left	Right
Median Width(ft)		24			24			12			12	
Link Offset(ft)		0			0			0			0	
Crosswalk Width(ft)		16			16			16			16	
Two way Left Turn Lane												
Headway Factor	1.00	1.00	1.00	1.00	1.00	1.00	1.00	1.00	1.00	1.00	1.00	1.00
Turning Speed (mph)	15		9	15		9	15		9	15		9
Number of Detectors		2	1	1	2					1	2	
Detector Template		Thru	Right	Left	Thru					Left	Thru	
Leading Detector (ft)		100	20	20	100					20	100	
Trailing Detector (ft)		0	0	0	0					0	0	
Detector 1 Position(ft)		0	0	0	0					0	0	
Detector 1 Size(ft)		6	20	20	6					20	6	
Detector 1 Type		Cl+Ex	Cl+Ex	Cl+Ex	Cl+Ex					Cl+Ex	Cl+Ex	
Detector 1 Channel												
Detector 1 Extend (s)		0.0	0.0	0.0	0.0					0.0	0.0	
Detector 1 Queue (s)		0.0	0.0	0.0	0.0					0.0	0.0	
Detector 1 Delay (s)		0.0	0.0	0.0	0.0					0.0	0.0	
Detector 2 Position(ft)		94			94							94
Detector 2 Size(ft)		6			6							6
Detector 2 Type		Cl+Ex			Cl+Ex							Cl+Ex
Detector 2 Channel												
Detector 2 Extend (s)		0.0			0.0							0.0

Lanes, Volumes, Timings

Existing Project Alter. C Conditions

12: US 101 SB On Ramp/US 101 SB Off Ramp & Old Redwood Highway

Timing Plan: A.M. PEAK

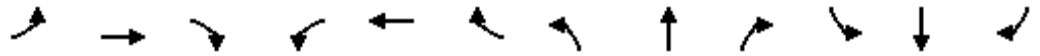

Lane Group	EBL	EBT	EBR	WBL	WBT	WBR	NBL	NBT	NBR	SBL	SBT	SBR
Turn Type		NA	Perm	Prot	NA					Perm	NA	
Protected Phases		6		5	2						8	
Permitted Phases			6							8		
Detector Phase		6	6	5	2					8	8	
Switch Phase												
Minimum Initial (s)		10.0	10.0	7.0	10.0					10.0	10.0	
Minimum Split (s)		32.1	32.1	11.0	38.1					14.7	14.7	
Total Split (s)		32.3	32.3	33.0	65.3					14.7	14.7	
Total Split (%)		40.4%	40.4%	41.3%	81.6%					18.4%	18.4%	
Maximum Green (s)		27.2	27.2	29.0	60.2					10.0	10.0	
Yellow Time (s)		4.1	4.1	3.0	4.1					3.7	3.7	
All-Red Time (s)		1.0	1.0	1.0	1.0					1.0	1.0	
Lost Time Adjust (s)		0.0	0.0	0.0	0.0					0.0	0.0	
Total Lost Time (s)		5.1	5.1	4.0	5.1					4.7	4.7	
Lead/Lag		Lag	Lag	Lead								
Lead-Lag Optimize?		Yes	Yes	Yes								
Vehicle Extension (s)		3.0	3.0	3.0	3.0					3.0	3.0	
Recall Mode		Max	Max	None	Max					None	None	
Walk Time (s)		7.0	7.0		7.0							
Flash Dont Walk (s)		20.0	20.0		25.0							
Pedestrian Calls (#/hr)		0	0		0							
Act Effct Green (s)		29.4	29.4	27.2	61.8					10.1	10.1	
Actuated g/C Ratio		0.38	0.38	0.35	0.80					0.13	0.13	
v/c Ratio		0.24	0.41	0.92	0.20					0.49	0.37	
Control Delay		18.7	4.2	47.4	2.8					40.9	15.7	
Queue Delay		0.0	0.0	0.0	0.0					0.0	0.0	
Total Delay		18.7	4.2	47.4	2.8					40.9	15.7	
LOS		B	A	D	A					D	B	
Approach Delay		11.5			25.3						28.8	
Approach LOS		B			C						C	

Intersection Summary





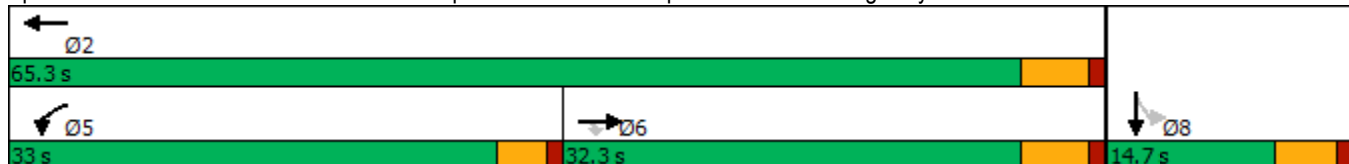

















Area Type: Other  
 Cycle Length: 80  
 Actuated Cycle Length: 77.1  
 Natural Cycle: 80  
 Control Type: Actuated-Uncoordinated  
 Maximum v/c Ratio: 0.92  
 Intersection Signal Delay: 21.2  
 Intersection LOS: C  
 Intersection Capacity Utilization 70.8%  
 ICU Level of Service C  
 Analysis Period (min) 15

Splits and Phases: 12: US 101 SB On Ramp/US 101 SB Off Ramp & Old Redwood Highway



Lanes, Volumes, Timings  
1: Old Redwood Hwy & Shiloh Road

Existing Project Alter. C Conditions  
Timing Plan: P.M. Peak

												
Lane Group	EBL	EBT	EBR	WBL	WBT	WBR	NBL	NBT	NBR	SBL	SBT	SBR
Lane Configurations												
Traffic Volume (vph)	241	146	174	37	137	23	153	339	21	31	235	146
Future Volume (vph)	241	146	174	37	137	23	153	339	21	31	235	146
Ideal Flow (vphpl)	1900	1900	1900	1900	1900	1900	1900	1900	1900	1900	1900	1900
Storage Length (ft)	375		140	0		50	200		98	130		93
Storage Lanes	1		1	0		1	1		1	1		1
Taper Length (ft)	50			25			60			93		
Lane Util. Factor	1.00	1.00	1.00	1.00	1.00	1.00	1.00	1.00	1.00	1.00	1.00	1.00
Ped Bike Factor	1.00					0.98	1.00		0.98			0.97
Frt			0.850			0.850			0.850			0.850
Flt Protected	0.950				0.989		0.950			0.950		
Satd. Flow (prot)	1770	1863	1583	0	1842	1583	1770	1863	1583	1770	1863	1583
Flt Permitted	0.950				0.989		0.950			0.950		
Satd. Flow (perm)	1767	1863	1583	0	1842	1549	1767	1863	1546	1770	1863	1542
Right Turn on Red			Yes			Yes			Yes			Yes
Satd. Flow (RTOR)			179			105			77			105
Link Speed (mph)		40			40			45				40
Link Distance (ft)		1789			608			748				775
Travel Time (s)		30.5			10.4			11.3				13.2
Confl. Peds. (#/hr)	1						1	1				1
Confl. Bikes (#/hr)									3			3
Peak Hour Factor	0.97	0.97	0.97	0.91	0.91	0.91	0.93	0.93	0.93	0.93	0.93	0.93
Adj. Flow (vph)	248	151	179	41	151	25	165	365	23	33	253	157
Shared Lane Traffic (%)												
Lane Group Flow (vph)	248	151	179	0	192	25	165	365	23	33	253	157
Enter Blocked Intersection	No	No	No	No	No	No	No	No	No	No	No	No
Lane Alignment	Left	Left	Right	Left	Left	Right	Left	Left	Right	Left	Left	Right
Median Width(ft)		12			12			12				12
Link Offset(ft)		0			0			0				0
Crosswalk Width(ft)		16			16			16				16
Two way Left Turn Lane												
Headway Factor	1.00	1.00	1.00	1.00	1.00	1.00	1.00	1.00	1.00	1.00	1.00	1.00
Turning Speed (mph)	15		9	15		9	15		9	15		9
Number of Detectors	1	2	1	1	2	1	1	2	1	1	2	1
Detector Template	Left	Thru	Right	Left	Thru	Right	Left	Thru	Right	Left	Thru	Right
Leading Detector (ft)	20	100	20	20	100	20	20	100	20	20	100	20
Trailing Detector (ft)	0	0	0	0	0	0	0	0	0	0	0	0
Detector 1 Position(ft)	0	0	0	0	0	0	0	0	0	0	0	0
Detector 1 Size(ft)	20	6	20	20	6	20	20	6	20	20	6	20
Detector 1 Type	Cl+Ex	Cl+Ex	Cl+Ex	Cl+Ex	Cl+Ex	Cl+Ex	Cl+Ex	Cl+Ex	Cl+Ex	Cl+Ex	Cl+Ex	Cl+Ex
Detector 1 Channel												
Detector 1 Extend (s)	0.0	0.0	0.0	0.0	0.0	0.0	0.0	0.0	0.0	0.0	0.0	0.0
Detector 1 Queue (s)	0.0	0.0	0.0	0.0	0.0	0.0	0.0	0.0	0.0	0.0	0.0	0.0
Detector 1 Delay (s)	0.0	0.0	0.0	0.0	0.0	0.0	0.0	0.0	0.0	0.0	0.0	0.0
Detector 2 Position(ft)		94			94			94				94
Detector 2 Size(ft)		6			6			6				6
Detector 2 Type		Cl+Ex			Cl+Ex			Cl+Ex				Cl+Ex
Detector 2 Channel												
Detector 2 Extend (s)		0.0			0.0			0.0				0.0

Lanes, Volumes, Timings  
1: Old Redwood Hwy & Shiloh Road

Existing Project Alter. C Conditions  
Timing Plan: P.M. Peak



Lane Group	EBL	EBT	EBR	WBL	WBT	WBR	NBL	NBT	NBR	SBL	SBT	SBR
Turn Type	Split	NA	Perm	Split	NA	Perm	Prot	NA	Perm	Prot	NA	Perm
Protected Phases	2	2		6	6		3	8		7	4	
Permitted Phases			2			6			8			4
Detector Phase	2	2	2	6	6	6	3	8	8	7	4	4
Switch Phase												
Minimum Initial (s)	5.0	5.0	5.0	5.0	5.0	5.0	5.0	5.0	5.0	5.0	5.0	5.0
Minimum Split (s)	34.5	34.5	34.5	42.5	42.5	42.5	8.5	46.5	46.5	8.5	39.5	39.5
Total Split (s)	35.0	35.0	35.0	42.5	42.5	42.5	18.0	48.0	48.0	9.5	39.5	39.5
Total Split (%)	25.9%	25.9%	25.9%	31.5%	31.5%	31.5%	13.3%	35.6%	35.6%	7.0%	29.3%	29.3%
Maximum Green (s)	30.5	30.5	30.5	38.0	38.0	38.0	14.5	43.5	43.5	6.0	35.0	35.0
Yellow Time (s)	3.5	3.5	3.5	3.5	3.5	3.5	3.0	3.5	3.5	3.0	3.5	3.5
All-Red Time (s)	1.0	1.0	1.0	1.0	1.0	1.0	0.5	1.0	1.0	0.5	1.0	1.0
Lost Time Adjust (s)	0.0	0.0	0.0		0.0	0.0	0.0	0.0	0.0	0.0	0.0	0.0
Total Lost Time (s)	4.5	4.5	4.5		4.5	4.5	3.5	4.5	4.5	3.5	4.5	4.5
Lead/Lag	Lead	Lead	Lead	Lag	Lag	Lag	Lead	Lag	Lag	Lead	Lag	Lag
Lead-Lag Optimize?	Yes	Yes	Yes	Yes	Yes	Yes	Yes	Yes	Yes	Yes	Yes	Yes
Vehicle Extension (s)	3.0	3.0	3.0	3.0	3.0	3.0	3.0	3.0	3.0	3.0	3.0	3.0
Recall Mode	None	None	None	None	None	None	None	None	None	None	None	None
Walk Time (s)	7.0	7.0	7.0	7.0	7.0	7.0		7.0	7.0		7.0	7.0
Flash Dont Walk (s)	23.0	23.0	23.0	31.0	31.0	31.0		35.0	35.0		28.0	28.0
Pedestrian Calls (#/hr)	0	0	0	0	0	0		0	0		0	0
Act Effct Green (s)	18.4	18.4	18.4		15.0	15.0	13.7	29.9	29.9	6.2	17.6	17.6
Actuated g/C Ratio	0.22	0.22	0.22		0.18	0.18	0.17	0.36	0.36	0.08	0.21	0.21
v/c Ratio	0.63	0.36	0.36		0.58	0.07	0.56	0.54	0.04	0.25	0.64	0.38
Control Delay	38.5	31.9	7.2		41.0	0.3	44.8	28.0	0.1	48.6	39.5	15.1
Queue Delay	0.0	0.0	0.0		0.0	0.0	0.0	0.0	0.0	0.0	0.0	0.0
Total Delay	38.5	31.9	7.2		41.0	0.3	44.8	28.0	0.1	48.6	39.5	15.1
LOS	D	C	A		D	A	D	C	A	D	D	B
Approach Delay		27.1			36.3			31.9			31.5	
Approach LOS		C			D			C			C	

Intersection Summary

Area Type: Other  
 Cycle Length: 135  
 Actuated Cycle Length: 82.5  
 Natural Cycle: 135  
 Control Type: Actuated-Uncoordinated  
 Maximum v/c Ratio: 0.64  
 Intersection Signal Delay: 30.8  
 Intersection LOS: C  
 Intersection Capacity Utilization 59.9%  
 ICU Level of Service B  
 Analysis Period (min) 15

Splits and Phases: 1: Old Redwood Hwy & Shiloh Road





Lanes, Volumes, Timings  
2: Shiloh Road & Hembree Ln

Existing Project Alter. C Conditions  
Timing Plan: P.M. Peak



Lane Group	EBL	EBT	WBT	WBR	SBL	SBR
Lane Configurations	↶↶	↶	↶↶		↶	↷
Traffic Volume (vph)	615	410	320	141	170	491
Future Volume (vph)	615	410	320	141	170	491
Ideal Flow (vphp)	1900	1900	1900	1900	1900	1900
Storage Length (ft)	0			130	0	0
Storage Lanes	2			1	1	1
Taper Length (ft)	25				25	
Lane Util. Factor	0.97	1.00	0.95	0.95	1.00	1.00
Ped Bike Factor	1.00		1.00			
Frt			0.954			0.850
Flt Protected	0.950				0.950	
Satd. Flow (prot)	3433	1863	3363	0	1770	1583
Flt Permitted	0.950				0.950	
Satd. Flow (perm)	3429	1863	3363	0	1770	1583
Right Turn on Red				Yes		Yes
Satd. Flow (RTOR)			100			369
Link Speed (mph)		40	40		35	
Link Distance (ft)		302	1789		381	
Travel Time (s)		5.1	30.5		7.4	
Confl. Peds. (#/hr)	2			2		
Peak Hour Factor	0.94	0.94	0.87	0.87	0.95	0.95
Adj. Flow (vph)	654	436	368	162	179	517
Shared Lane Traffic (%)						
Lane Group Flow (vph)	654	436	530	0	179	517
Enter Blocked Intersection	No	No	No	No	No	No
Lane Alignment	Left	Left	Left	Right	Left	Right
Median Width(ft)		24	24		12	
Link Offset(ft)		0	0		0	
Crosswalk Width(ft)		16	16		16	
Two way Left Turn Lane						
Headway Factor	1.00	1.00	1.00	1.00	1.00	1.00
Turning Speed (mph)	15			9	15	9
Number of Detectors	1	2	2		1	1
Detector Template	Left	Thru	Thru		Left	Right
Leading Detector (ft)	20	100	100		20	20
Trailing Detector (ft)	0	0	0		0	0
Detector 1 Position(ft)	0	0	0		0	0
Detector 1 Size(ft)	20	6	6		20	20
Detector 1 Type	Cl+Ex	Cl+Ex	Cl+Ex		Cl+Ex	Cl+Ex
Detector 1 Channel						
Detector 1 Extend (s)	0.0	0.0	0.0		0.0	0.0
Detector 1 Queue (s)	0.0	0.0	0.0		0.0	0.0
Detector 1 Delay (s)	0.0	0.0	0.0		0.0	0.0
Detector 2 Position(ft)		94	94			
Detector 2 Size(ft)		6	6			
Detector 2 Type		Cl+Ex	Cl+Ex			
Detector 2 Channel						
Detector 2 Extend (s)		0.0	0.0			
Turn Type	Prot	NA	NA		Perm	pm+ov

Lanes, Volumes, Timings  
2: Shiloh Road & Hembree Ln

Existing Project Alter. C Conditions  
Timing Plan: P.M. Peak



Lane Group	EBL	EBT	WBT	WBR	SBL	SBR
Protected Phases	5	2	6			5
Permitted Phases					4	4 5
Detector Phase	5	2	6		4	5
Switch Phase						
Minimum Initial (s)	3.0	5.0	5.0		5.0	3.0
Minimum Split (s)	7.0	9.0	43.0		9.0	7.0
Total Split (s)	29.0	73.0	44.0		17.0	29.0
Total Split (%)	32.2%	81.1%	48.9%		18.9%	32.2%
Maximum Green (s)	25.0	69.0	40.0		13.0	25.0
Yellow Time (s)	3.0	3.0	3.0		3.0	3.0
All-Red Time (s)	1.0	1.0	1.0		1.0	1.0
Lost Time Adjust (s)	0.0	0.0	0.0		0.0	0.0
Total Lost Time (s)	4.0	4.0	4.0		4.0	4.0
Lead/Lag	Lead		Lag			Lead
Lead-Lag Optimize?	Yes		Yes			Yes
Vehicle Extension (s)	3.0	3.0	3.0		3.0	3.0
Recall Mode	None	None	None		None	None
Walk Time (s)			7.0			
Flash Dont Walk (s)			32.0			
Pedestrian Calls (#/hr)			0			
Act Effct Green (s)	17.4	35.1	13.6		11.0	32.5
Actuated g/C Ratio	0.32	0.65	0.25		0.20	0.60
v/c Ratio	0.60	0.36	0.58		0.50	0.47
Control Delay	18.7	5.4	18.0		27.1	3.5
Queue Delay	0.0	0.0	0.0		0.0	0.0
Total Delay	18.7	5.4	18.0		27.1	3.5
LOS	B	A	B		C	A
Approach Delay		13.4	18.0		9.5	
Approach LOS		B	B		A	

Intersection Summary

Area Type:	Other
Cycle Length:	90
Actuated Cycle Length:	54.4
Natural Cycle:	75
Control Type:	Actuated-Uncoordinated
Maximum v/c Ratio:	0.60
Intersection Signal Delay:	13.3
Intersection LOS:	B
Intersection Capacity Utilization:	51.7%
ICU Level of Service:	A
Analysis Period (min):	15

Splits and Phases: 2: Shiloh Road & Hembree Ln



Lanes, Volumes, Timings  
3: US 101 NB Off-Ramp & Shiloh Road

Existing Project Alter. C Conditions  
Timing Plan: P.M. Peak

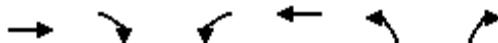

Lane Group	EBT	EBR	WBL	WBT	NBL	NBR
Lane Configurations	↑↑			↑	↘	↗↗
Traffic Volume (vph)	379	0	0	562	526	651
Future Volume (vph)	379	0	0	562	526	651
Ideal Flow (vphpl)	1900	1900	1900	1900	1900	1900
Storage Length (ft)		0	0		0	265
Storage Lanes		0	0		1	2
Taper Length (ft)			25		25	
Lane Util. Factor	0.95	1.00	1.00	1.00	1.00	0.88
Frt						0.850
Flt Protected					0.950	
Satd. Flow (prot)	3539	0	0	1863	1770	2787
Flt Permitted					0.950	
Satd. Flow (perm)	3539	0	0	1863	1770	2787
Right Turn on Red		Yes				Yes
Satd. Flow (RTOR)						615
Link Speed (mph)	40			40	30	
Link Distance (ft)	186			371	769	
Travel Time (s)	3.2			6.3	17.5	
Peak Hour Factor	0.94	0.94	0.97	0.97	0.90	0.90
Adj. Flow (vph)	403	0	0	579	584	723
Shared Lane Traffic (%)						
Lane Group Flow (vph)	403	0	0	579	584	723
Enter Blocked Intersection	No	No	No	No	No	No
Lane Alignment	Left	Right	Left	Left	Left	Right
Median Width(ft)	0			0	12	
Link Offset(ft)	0			0	0	
Crosswalk Width(ft)	16			16	16	
Two way Left Turn Lane						
Headway Factor	1.00	1.00	1.00	1.00	1.00	1.00
Turning Speed (mph)		9	15		15	9
Number of Detectors	2			2	1	1
Detector Template	Thru			Thru	Left	Right
Leading Detector (ft)	100			100	20	20
Trailing Detector (ft)	0			0	0	0
Detector 1 Position(ft)	0			0	0	0
Detector 1 Size(ft)	6			6	20	20
Detector 1 Type	Cl+Ex			Cl+Ex	Cl+Ex	Cl+Ex
Detector 1 Channel						
Detector 1 Extend (s)	0.0			0.0	0.0	0.0
Detector 1 Queue (s)	0.0			0.0	0.0	0.0
Detector 1 Delay (s)	0.0			0.0	0.0	0.0
Detector 2 Position(ft)	94			94		
Detector 2 Size(ft)	6			6		
Detector 2 Type	Cl+Ex			Cl+Ex		
Detector 2 Channel						
Detector 2 Extend (s)	0.0			0.0		
Turn Type	NA			NA	Prot	Perm
Protected Phases	2			6	8	
Permitted Phases						8

Lanes, Volumes, Timings  
 3: US 101 NB Off-Ramp & Shiloh Road

Existing Project Alter. C Conditions  
 Timing Plan: P.M. Peak

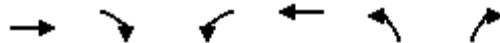

Lane Group	EBT	EBR	WBL	WBT	NBL	NBR
Detector Phase	2			6	8	8
Switch Phase						
Minimum Initial (s)	5.0			5.0	5.0	5.0
Minimum Split (s)	9.0			9.0	9.0	9.0
Total Split (s)	37.0			37.0	35.0	35.0
Total Split (%)	51.4%			51.4%	48.6%	48.6%
Maximum Green (s)	33.0			33.0	31.0	31.0
Yellow Time (s)	3.0			3.0	3.0	3.0
All-Red Time (s)	1.0			1.0	1.0	1.0
Lost Time Adjust (s)	0.0			0.0	0.0	0.0
Total Lost Time (s)	4.0			4.0	4.0	4.0
Lead/Lag						
Lead-Lag Optimize?						
Vehicle Extension (s)	3.0			3.0	3.0	3.0
Recall Mode	None			None	None	None
Act Effect Green (s)	23.2			23.2	24.3	24.3
Actuated g/C Ratio	0.41			0.41	0.43	0.43
v/c Ratio	0.28			0.75	0.76	0.46
Control Delay	11.9			21.9	22.7	3.4
Queue Delay	0.0			0.0	0.0	0.0
Total Delay	11.9			21.9	22.7	3.4
LOS	B			C	C	A
Approach Delay	11.9			21.9	12.0	
Approach LOS	B			C	B	

Intersection Summary

Area Type: Other  
 Cycle Length: 72  
 Actuated Cycle Length: 56.1  
 Natural Cycle: 50  
 Control Type: Actuated-Uncoordinated  
 Maximum v/c Ratio: 0.76  
 Intersection Signal Delay: 14.5  
 Intersection LOS: B  
 Intersection Capacity Utilization 100.7%  
 ICU Level of Service G  
 Analysis Period (min) 15

Splits and Phases: 3: US 101 NB Off-Ramp & Shiloh Road

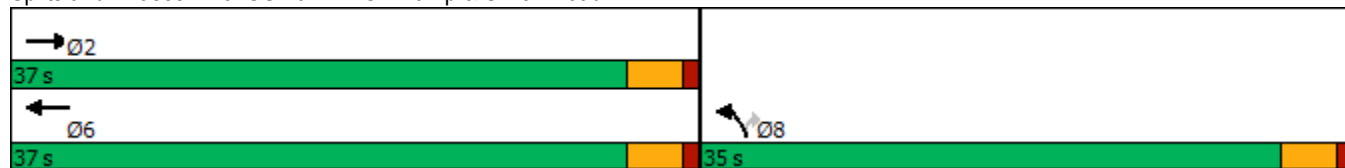

Lanes, Volumes, Timings  
4: Shiloh Road & US 101 SB Off-Ramp

Existing Project Alter. C Conditions  
Timing Plan: P.M. Peak



Lane Group	EBL	EBT	WBT	WBR	SBL	SBR
Lane Configurations		↑	↑		↓	↓
Traffic Volume (vph)	0	428	620	0	147	110
Future Volume (vph)	0	428	620	0	147	110
Ideal Flow (vphp)	1900	1900	1900	1900	1900	1900
Storage Length (ft)	0			0	0	275
Storage Lanes	0			0	1	1
Taper Length (ft)	25				25	
Lane Util. Factor	1.00	1.00	1.00	1.00	1.00	1.00
Ped Bike Factor						0.98
Frt						0.850
Flt Protected					0.950	
Satd. Flow (prot)	0	1863	1863	0	1770	1583
Flt Permitted					0.950	
Satd. Flow (perm)	0	1863	1863	0	1770	1548
Right Turn on Red				Yes		Yes
Satd. Flow (RTOR)						118
Link Speed (mph)		40	40		30	
Link Distance (ft)		225	306		486	
Travel Time (s)		3.8	5.2		11.0	
Confl. Peds. (#/hr)						1
Peak Hour Factor	0.89	0.89	0.96	0.96	0.93	0.93
Adj. Flow (vph)	0	481	646	0	158	118
Shared Lane Traffic (%)						
Lane Group Flow (vph)	0	481	646	0	158	118
Enter Blocked Intersection	No	No	No	No	No	No
Lane Alignment	Left	Left	Left	Right	Left	Right
Median Width(ft)		4	0		12	
Link Offset(ft)		0	0		0	
Crosswalk Width(ft)		16	16		16	
Two way Left Turn Lane						
Headway Factor	1.00	1.00	1.00	1.00	1.00	1.00
Turning Speed (mph)	15			9	15	9
Number of Detectors		2	2		1	1
Detector Template		Thru	Thru		Left	Right
Leading Detector (ft)		100	100		20	20
Trailing Detector (ft)		0	0		0	0
Detector 1 Position(ft)		0	0		0	0
Detector 1 Size(ft)		6	6		20	20
Detector 1 Type		Cl+Ex	Cl+Ex		Cl+Ex	Cl+Ex
Detector 1 Channel						
Detector 1 Extend (s)		0.0	0.0		0.0	0.0
Detector 1 Queue (s)		0.0	0.0		0.0	0.0
Detector 1 Delay (s)		0.0	0.0		0.0	0.0
Detector 2 Position(ft)		94	94			
Detector 2 Size(ft)		6	6			
Detector 2 Type		Cl+Ex	Cl+Ex			
Detector 2 Channel						
Detector 2 Extend (s)		0.0	0.0			
Turn Type		NA	NA		Perm	Perm

Lanes, Volumes, Timings  
4: Shiloh Road & US 101 SB Off-Ramp

Existing Project Alter. C Conditions  
Timing Plan: P.M. Peak



Lane Group	EBL	EBT	WBT	WBR	SBL	SBR
Protected Phases		2	6			
Permitted Phases					4	4
Detector Phase		2	6		4	4
Switch Phase						
Minimum Initial (s)		5.0	5.0		5.0	5.0
Minimum Split (s)		9.0	38.0		9.0	9.0
Total Split (s)		69.0	69.0		21.0	21.0
Total Split (%)		76.7%	76.7%		23.3%	23.3%
Maximum Green (s)		65.0	65.0		17.0	17.0
Yellow Time (s)		3.0	3.0		3.0	3.0
All-Red Time (s)		1.0	1.0		1.0	1.0
Lost Time Adjust (s)		0.0	0.0		0.0	0.0
Total Lost Time (s)		4.0	4.0		4.0	4.0
Lead/Lag						
Lead-Lag Optimize?						
Vehicle Extension (s)		3.0	3.0		3.0	3.0
Recall Mode		None	None		None	None
Walk Time (s)			7.0			
Flash Dont Walk (s)			27.0			
Pedestrian Calls (#/hr)			0			
Act Effct Green (s)		22.4	22.4		9.6	9.6
Actuated g/C Ratio		0.64	0.64		0.28	0.28
v/c Ratio		0.40	0.54		0.32	0.23
Control Delay		6.2	7.7		15.8	5.3
Queue Delay		0.0	0.0		0.0	0.0
Total Delay		6.2	7.7		15.8	5.3
LOS		A	A		B	A
Approach Delay		6.2	7.7		11.3	
Approach LOS		A	A		B	

Intersection Summary

Area Type:	Other
Cycle Length:	90
Actuated Cycle Length:	34.9
Natural Cycle:	50
Control Type:	Actuated-Uncoordinated
Maximum v/c Ratio:	0.54
Intersection Signal Delay:	7.9
Intersection LOS:	A
Intersection Capacity Utilization:	61.0%
ICU Level of Service:	B
Analysis Period (min):	15

Splits and Phases: 4: Shiloh Road & US 101 SB Off-Ramp





















Lanes, Volumes, Timings  
5: Caletti Ave & Shiloh Road

Existing Project Alter. C Conditions  
Timing Plan: P.M. Peak

	→	↘	↙	←	↖	↗
Lane Group	EBT	EBR	WBL	WBT	NBL	NBR
Lane Configurations	↑↑		↘	↑	↘	↗
Traffic Volume (vph)	856	28	79	656	15	149
Future Volume (vph)	856	28	79	656	15	149
Ideal Flow (vphpl)	1900	1900	1900	1900	1900	1900
Storage Length (ft)		0	68		0	0
Storage Lanes		0	1		1	1
Taper Length (ft)			50		25	
Lane Util. Factor	0.95	0.95	1.00	1.00	1.00	1.00
Frt	0.995					0.850
Flt Protected			0.950		0.950	
Satd. Flow (prot)	3522	0	1770	1863	1770	1583
Flt Permitted			0.950		0.950	
Satd. Flow (perm)	3522	0	1770	1863	1770	1583
Link Speed (mph)	40			40	30	
Link Distance (ft)	1081			184	459	
Travel Time (s)	18.4			3.1	10.4	
Peak Hour Factor	0.89	0.89	0.92	0.92	0.89	0.89
Adj. Flow (vph)	962	31	86	713	17	167
Shared Lane Traffic (%)						
Lane Group Flow (vph)	993	0	86	713	17	167
Enter Blocked Intersection	No	No	No	No	No	No
Lane Alignment	Left	Right	Left	Left	Left	Right
Median Width(ft)	12			12	12	
Link Offset(ft)	0			0	0	
Crosswalk Width(ft)	16			16	16	
Two way Left Turn Lane						
Headway Factor	1.00	1.00	1.00	1.00	1.00	1.00
Turning Speed (mph)		9	15		15	9
Sign Control	Free			Free	Stop	
<b>Intersection Summary</b>						
Area Type:	Other					
Control Type:	Unsignalized					
Intersection Capacity Utilization	44.5%			ICU Level of Service A		
Analysis Period (min)	15					

Lanes, Volumes, Timings  
6: Conde Lane & Shiloh Road

Existing Project Alter. C Conditions  
Timing Plan: P.M. Peak

												
Lane Group	EBL	EBT	EBR	WBL	WBT	WBR	NBL	NBT	NBR	SBL	SBT	SBR
Lane Configurations												
Traffic Volume (vph)	69	475	2	7	461	289	5	3	17	297	0	39
Future Volume (vph)	69	475	2	7	461	289	5	3	17	297	0	39
Ideal Flow (vphpl)	1900	1900	1900	1900	1900	1900	1900	1900	1900	1900	1900	1900
Storage Length (ft)	90		0	127		0	0		0	0		40
Storage Lanes	1		0	1		0	0		0	0		1
Taper Length (ft)	70			40			25			25		
Lane Util. Factor	1.00	0.95	0.95	1.00	0.95	0.95	1.00	1.00	1.00	1.00	1.00	1.00
Ped Bike Factor	1.00				0.99							
Frt		0.999			0.942			0.909				0.850
Flt Protected	0.950			0.950				0.990			0.950	
Satd. Flow (prot)	1770	3536	0	1770	3307	0	0	1676	0	0	1770	1583
Flt Permitted	0.950			0.950				0.990			0.950	
Satd. Flow (perm)	1767	3536	0	1770	3307	0	0	1676	0	0	1770	1583
Right Turn on Red			Yes			Yes			Yes			No
Satd. Flow (RTOR)					143			27				
Link Speed (mph)		40			40			30				35
Link Distance (ft)		815			1081			418				522
Travel Time (s)		13.9			18.4			9.5				10.2
Confl. Peds. (#/hr)	1						1					
Peak Hour Factor	0.88	0.88	0.88	0.80	0.80	0.80	0.63	0.63	0.63	0.88	0.88	0.88
Adj. Flow (vph)	78	540	2	9	576	361	8	5	27	338	0	44
Shared Lane Traffic (%)												
Lane Group Flow (vph)	78	542	0	9	937	0	0	40	0	0	338	44
Enter Blocked Intersection	No	No	No	No	No	No	No	No	No	No	No	No
Lane Alignment	Left	Left	Right	Left	Left	Right	Left	Left	Right	Left	Left	Right
Median Width(ft)		12			12			0				0
Link Offset(ft)		0			0			0				0
Crosswalk Width(ft)		16			16			16				16
Two way Left Turn Lane												
Headway Factor	1.00	1.00	1.00	1.00	1.00	1.00	1.00	1.00	1.00	1.00	1.00	1.00
Turning Speed (mph)	15		9	15		9	15		9	15		9
Number of Detectors	1	2		1	2		1	2		1	1	1
Detector Template	Left	Thru		Left	Thru		Left	Thru		Left	Thru	Right
Leading Detector (ft)	20	100		20	100		20	100		20	30	20
Trailing Detector (ft)	0	0		0	0		0	0		0	0	0
Detector 1 Position(ft)	0	0		0	0		0	0		0	0	0
Detector 1 Size(ft)	20	6		20	6		20	6		20	30	20
Detector 1 Type	Cl+Ex	Cl+Ex		Cl+Ex	Cl+Ex		Cl+Ex	Cl+Ex		Cl+Ex	Cl+Ex	Cl+Ex
Detector 1 Channel												
Detector 1 Extend (s)	0.0	0.0		0.0	0.0		0.0	0.0		0.0	0.0	0.0
Detector 1 Queue (s)	0.0	0.0		0.0	0.0		0.0	0.0		0.0	0.0	0.0
Detector 1 Delay (s)	0.0	0.0		0.0	0.0		0.0	0.0		0.0	0.0	0.0
Detector 2 Position(ft)		94			94			94				
Detector 2 Size(ft)		6			6			6				
Detector 2 Type		Cl+Ex			Cl+Ex			Cl+Ex				
Detector 2 Channel												
Detector 2 Extend (s)		0.0			0.0			0.0				
Turn Type	Prot	NA		Prot	NA		Split	NA		Split	NA	custom



Lanes, Volumes, Timings  
6: Conde Lane & Shiloh Road

Existing Project Alter. C Conditions  
Timing Plan: P.M. Peak

Lane Group	EBL	EBT	EBR	WBL	WBT	WBR	NBL	NBT	NBR	SBL	SBT	SBR
Protected Phases	5	2		1	6		7	7		4	4	
Permitted Phases												6
Detector Phase	5	2		1	6		7	7		4	4	6
Switch Phase												
Minimum Initial (s)	8.0	8.0		8.0	8.0		10.0	10.0		11.0	11.0	8.0
Minimum Split (s)	12.0	46.0		12.0	12.0		37.0	37.0		15.0	15.0	12.0
Total Split (s)	13.0	46.0		12.0	45.0		37.0	37.0		15.0	15.0	45.0
Total Split (%)	11.8%	41.8%		10.9%	40.9%		33.6%	33.6%		13.6%	13.6%	40.9%
Maximum Green (s)	9.0	42.0		8.0	41.0		33.0	33.0		11.0	11.0	41.0
Yellow Time (s)	3.0	3.0		3.0	3.0		3.0	3.0		3.0	3.0	3.0
All-Red Time (s)	1.0	1.0		1.0	1.0		1.0	1.0		1.0	1.0	1.0
Lost Time Adjust (s)	0.0	0.0		0.0	0.0		0.0	0.0		0.0	0.0	0.0
Total Lost Time (s)	4.0	4.0		4.0	4.0		4.0	4.0		4.0	4.0	4.0
Lead/Lag	Lead	Lag		Lead	Lag							Lag
Lead-Lag Optimize?	Yes	Yes		Yes	Yes							Yes
Vehicle Extension (s)	3.0	3.0		3.0	3.0		3.0	3.0		3.0	3.0	3.0
Recall Mode	None	None		None	None		None	None		None	None	None
Walk Time (s)		7.0					7.0	7.0				
Flash Dont Walk (s)		35.0					26.0	26.0				
Pedestrian Calls (#/hr)		0					0	0				
Act Effct Green (s)	9.6	30.4		9.1	22.9		11.4	11.4		12.5	12.5	22.9
Actuated g/C Ratio	0.16	0.50		0.15	0.38		0.19	0.19		0.21	0.21	0.38
v/c Ratio	0.28	0.31		0.03	0.70		0.12	0.12		0.93	0.93	0.07
Control Delay	32.9	10.4		31.7	17.6		17.6	17.6		67.2	67.2	14.5
Queue Delay	0.0	0.0		0.0	0.0		0.0	0.0		0.0	0.0	0.0
Total Delay	32.9	10.4		31.7	17.6		17.6	17.6		67.2	67.2	14.5
LOS	C	B		C	B		B	B		E	E	B
Approach Delay		13.2			17.7		17.6	17.6		61.1	61.1	
Approach LOS		B			B		B	B		E	E	

Intersection Summary





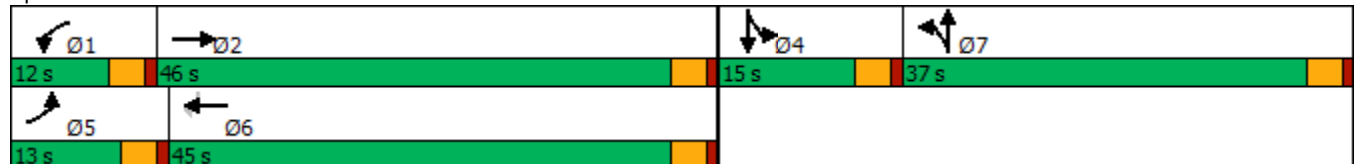











Area Type:	Other
Cycle Length:	110
Actuated Cycle Length:	60.7
Natural Cycle:	120
Control Type:	Actuated-Uncoordinated
Maximum v/c Ratio:	0.93
Intersection Signal Delay:	24.6
Intersection LOS:	C
Intersection Capacity Utilization:	61.8%
ICU Level of Service:	B
Analysis Period (min):	15

Splits and Phases: 6: Conde Lane & Shiloh Road



Lanes, Volumes, Timings  
7: Entrance 1/Gridley Drive & Shiloh Road

Existing Project Alter. C Conditions  
Timing Plan: P.M. Peak

												
Lane Group	EBL	EBT	EBR	WBL	WBT	WBR	NBL	NBT	NBR	SBL	SBT	SBR
Lane Configurations												
Traffic Volume (vph)	17	103	70	5	125	0	66	0	5	0	0	14
Future Volume (vph)	17	103	70	5	125	0	66	0	5	0	0	14
Ideal Flow (vphpl)	1900	1900	1900	1900	1900	1900	1900	1900	1900	1900	1900	1900
Lane Util. Factor	1.00	1.00	1.00	1.00	1.00	1.00	1.00	1.00	1.00	1.00	1.00	1.00
Ped Bike Factor												
Frt		0.951						0.850			0.865	
Flt Protected		0.996			0.998		0.950					
Satd. Flow (prot)	0	1764	0	0	1859	0	1770	1583	0	0	1611	0
Flt Permitted		0.996			0.998		0.950					
Satd. Flow (perm)	0	1764	0	0	1859	0	1770	1583	0	0	1611	0
Link Speed (mph)		40			40			30			30	
Link Distance (ft)		608			2146			248			715	
Travel Time (s)		10.4			36.6			5.6			16.3	
Confl. Peds. (#/hr)	1											
Confl. Bikes (#/hr)			1									
Peak Hour Factor	0.94	0.94	0.94	0.69	0.69	0.69	1.00	1.00	1.00	0.58	0.58	0.58
Adj. Flow (vph)	18	110	74	7	181	0	66	0	5	0	0	24
Shared Lane Traffic (%)												
Lane Group Flow (vph)	0	202	0	0	188	0	66	5	0	0	24	0
Enter Blocked Intersection	No	No	No	No	No	No	No	No	No	No	No	No
Lane Alignment	Left	Left	Right	Left	Left	Right	Left	Left	Right	Left	Left	Right
Median Width(ft)		0			0			12			12	
Link Offset(ft)		0			0			0			0	
Crosswalk Width(ft)		16			16			16			16	
Two way Left Turn Lane												
Headway Factor	1.00	1.00	1.00	1.00	1.00	1.00	1.00	1.00	1.00	1.00	1.00	1.00
Turning Speed (mph)	15		9	15		9	15		9	15		9
Sign Control		Free			Free			Stop			Stop	
<b>Intersection Summary</b>												
Area Type:	Other											
Control Type:	Unsignalized											
Intersection Capacity Utilization	33.9%						ICU Level of Service A					
Analysis Period (min)	15											

Lanes, Volumes, Timings  
8: Old Redwood Hwy & Entrance 1

Existing Project Alter. C Conditions  
Timing Plan: P.M. Peak

Lane Group	EBL	EBT	EBR	WBL	WBT	WBR	NBL	NBT	NBR	SBL	SBT	SBR
Lane Configurations												
Traffic Volume (vph)	3	0	0	9	0	15	0	505	10	16	427	0
Future Volume (vph)	3	0	0	9	0	15	0	505	10	16	427	0
Ideal Flow (vphp)	1900	1900	1900	1900	1900	1900	1900	1900	1900	1900	1900	1900
Storage Length (ft)	0		0	0		0	0		0	50		0
Storage Lanes	0		0	1		0	0		0	1		0
Taper Length (ft)	25			25			25			25		
Lane Util. Factor	1.00	1.00	1.00	1.00	1.00	1.00	1.00	1.00	1.00	1.00	1.00	1.00
Ped Bike Factor												
Fr <sub>t</sub>					0.850			0.997				
Fl <sub>t</sub> Protected		0.950		0.950						0.950		
Satd. Flow (prot)	0	1770	0	1770	1583	0	0	1857	0	1770	1863	0
Fl <sub>t</sub> Permitted		0.950		0.950						0.950		
Satd. Flow (perm)	0	1770	0	1770	1583	0	0	1857	0	1770	1863	0
Link Speed (mph)		30			30			45			45	
Link Distance (ft)		98			385			520			748	
Travel Time (s)		2.2			8.8			7.9			11.3	
Confl. Bikes (#/hr)									3			5
Peak Hour Factor	0.38	0.38	0.38	1.00	1.00	1.00	0.91	0.91	0.91	0.94	0.94	0.94
Adj. Flow (vph)	8	0	0	9	0	15	0	555	11	17	454	0
Shared Lane Traffic (%)												
Lane Group Flow (vph)	0	8	0	9	15	0	0	566	0	17	454	0
Enter Blocked Intersection	No	No	No	No	No	No	No	No	No	No	No	No
Lane Alignment	Left	Left	Right	Left	Left	Right	Left	Left	Right	Left	Left	Right
Median Width(ft)		12			12			12			12	
Link Offset(ft)		0			0			0			0	
Crosswalk Width(ft)		16			16			16			16	
Two way Left Turn Lane												
Headway Factor	1.00	1.00	1.00	1.00	1.00	1.00	1.00	1.00	1.00	1.00	1.00	1.00
Turning Speed (mph)	15		9	15		9	15		9	15		9
Sign Control		Stop			Stop			Free			Free	
<b>Intersection Summary</b>												
Area Type:	Other											
Control Type:	Unsignalized											
Intersection Capacity Utilization	37.2%						ICU Level of Service A					
Analysis Period (min)	15											

Lanes, Volumes, Timings  
9: Entrance 2 & Shiloh Road

Existing Project Alter. C Conditions  
Timing Plan: P.M. Peak

	→	↘	↙	←	↖	↗
Lane Group	EBT	EBR	WBL	WBT	NBL	NBR
Lane Configurations	↗			↖	↘	↗
Traffic Volume (vph)	86	0	0	116	0	0
Future Volume (vph)	86	0	0	116	0	0
Ideal Flow (vphpl)	1900	1900	1900	1900	1900	1900
Lane Util. Factor	1.00	1.00	1.00	1.00	1.00	1.00
<b>Fr</b>						
Flt Protected						
Satd. Flow (prot)	1863	0	0	1863	1863	1863
Flt Permitted						
Satd. Flow (perm)	1863	0	0	1863	1863	1863
Link Speed (mph)	40			40	30	
Link Distance (ft)	2146			134	402	
Travel Time (s)	36.6			2.3	9.1	
Peak Hour Factor	0.92	0.92	0.68	0.68	1.00	1.00
Adj. Flow (vph)	93	0	0	171	0	0
Shared Lane Traffic (%)						
Lane Group Flow (vph)	93	0	0	171	0	0
Enter Blocked Intersection	No	No	No	No	No	No
Lane Alignment	Left	Right	Left	Left	Left	Right
Median Width(ft)	0			0	12	
Link Offset(ft)	0			0	0	
Crosswalk Width(ft)	16			16	16	
Two way Left Turn Lane						
Headway Factor	1.00	1.00	1.00	1.00	1.00	1.00
Turning Speed (mph)		9	15		15	9
Sign Control	Free			Free	Stop	
<b>Intersection Summary</b>						
Area Type:	Other					
Control Type:	Unsignalized					
Intersection Capacity Utilization	9.4%			ICU Level of Service A		
Analysis Period (min)	15					

Lanes, Volumes, Timings

Existing Project Alter. C Conditions

10: US 101 NB Off Ramp/Lakewood Drive & Old Redwood Highway

Timing Plan: P.M. Peak



Lane Group	EBL	EBT	EBR	WBL	WBT	WBR	NBL	NBT	NBR	SBL	SBT	SBR
Lane Configurations												
Traffic Volume (vph)	261	360	0	0	506	192	500	412	251	249	0	577
Future Volume (vph)	261	360	0	0	506	192	500	412	251	249	0	577
Ideal Flow (vphpl)	1900	1900	1900	1900	1900	1900	1900	1900	1900	1900	1900	1900
Storage Length (ft)	155		0	0		0	270		150	120		0
Storage Lanes	1		0	0		0	1		1	1		1
Taper Length (ft)	50			25			165			75		
Lane Util. Factor	0.97	1.00	1.00	1.00	0.95	0.95	0.91	0.91	0.95	0.97	1.00	1.00
Ped Bike Factor	1.00				0.99			0.99		1.00		
Fr <sub>t</sub>					0.959			0.951				0.850
Fl <sub>t</sub> Protected	0.950						0.950	0.993		0.950		
Satd. Flow (prot)	3433	1863	0	0	3374	0	1610	3181	0	3433	0	1583
Fl <sub>t</sub> Permitted	0.950						0.950	0.993		0.950		
Satd. Flow (perm)	3426	1863	0	0	3374	0	1610	3181	0	3420	0	1583
Right Turn on Red			Yes			Yes			Yes			Yes
Satd. Flow (RTOR)					63			85				297
Link Speed (mph)		35			35			30				30
Link Distance (ft)		226			617			716				478
Travel Time (s)		4.4			12.0			16.3				10.9
Confl. Peds. (#/hr)	3		1	1		3			8	8		
Confl. Bikes (#/hr)			2			9						
Peak Hour Factor	0.87	0.87	0.87	0.91	0.91	0.91	0.92	0.92	0.92	0.96	0.96	0.96
Adj. Flow (vph)	300	414	0	0	556	211	543	448	273	259	0	601
Shared Lane Traffic (%)							22%					
Lane Group Flow (vph)	300	414	0	0	767	0	424	840	0	259	0	601
Enter Blocked Intersection	No	No	No	No	No	No	No	No	No	No	No	No
Lane Alignment	Left	Left	Right	Left	Left	Right	Left	Left	Right	Left	Left	Right
Median Width(ft)		24			24			24				24
Link Offset(ft)		0			0			0				0
Crosswalk Width(ft)		16			16			16				16
Two way Left Turn Lane												
Headway Factor	1.00	1.00	1.00	1.00	1.00	1.00	1.00	1.00	1.00	1.00	1.00	1.00
Turning Speed (mph)	15		9	15		9	15		9	15		9
Number of Detectors	1	2			2		1	2		1		1
Detector Template	Left	Thru			Thru		Left	Thru		Left		Right
Leading Detector (ft)	20	100			100		20	100		20		20
Trailing Detector (ft)	0	0			0		0	0		0		0
Detector 1 Position(ft)	0	0			0		0	0		0		0
Detector 1 Size(ft)	20	6			6		20	6		20		20
Detector 1 Type	Cl+Ex	Cl+Ex			Cl+Ex		Cl+Ex	Cl+Ex		Cl+Ex		Cl+Ex
Detector 1 Channel												
Detector 1 Extend (s)	0.0	0.0			0.0		0.0	0.0		0.0		0.0
Detector 1 Queue (s)	0.0	0.0			0.0		0.0	0.0		0.0		0.0
Detector 1 Delay (s)	0.0	0.0			0.0		0.0	0.0		0.0		0.0
Detector 2 Position(ft)		94			94			94				
Detector 2 Size(ft)		6			6			6				
Detector 2 Type		Cl+Ex			Cl+Ex			Cl+Ex				
Detector 2 Channel												
Detector 2 Extend (s)		0.0			0.0			0.0				

Lanes, Volumes, Timings

Existing Project Alter. C Conditions

10: US 101 NB Off Ramp/Lakewood Drive & Old Redwood Highway

Timing Plan: P.M. Peak

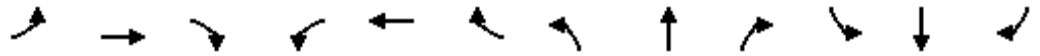

Lane Group	EBL	EBT	EBR	WBL	WBT	WBR	NBL	NBT	NBR	SBL	SBT	SBR
Turn Type	Prot	NA			NA		Split	NA		Prot		pm+ov
Protected Phases	5	2			6		8	8		7		5
Permitted Phases												5 8
Detector Phase	5	2			6		8	8		7		5
Switch Phase												
Minimum Initial (s)	7.0	10.0			10.0		10.0	10.0		7.0		7.0
Minimum Split (s)	11.0	32.1			32.1		33.7	33.7		11.0		11.0
Total Split (s)	13.0	45.3			32.3		33.7	33.7		11.0		13.0
Total Split (%)	14.4%	50.3%			35.9%		37.4%	37.4%		12.2%		14.4%
Maximum Green (s)	9.0	40.2			27.2		29.0	29.0		7.0		9.0
Yellow Time (s)	3.0	4.1			4.1		3.7	3.7		3.0		3.0
All-Red Time (s)	1.0	1.0			1.0		1.0	1.0		1.0		1.0
Lost Time Adjust (s)	0.0	0.0			0.0		0.0	0.0		0.0		0.0
Total Lost Time (s)	4.0	5.1			5.1		4.7	4.7		4.0		4.0
Lead/Lag	Lead				Lag		Lag	Lag		Lead		Lead
Lead-Lag Optimize?	Yes				Yes		Yes	Yes		Yes		Yes
Vehicle Extension (s)	3.0	3.0			3.0		3.0	3.0		3.0		3.0
Recall Mode	None	Max			Max		None	None		None		None
Walk Time (s)		7.0			7.0		7.0	7.0				
Flash Dont Walk (s)		20.0			17.0		22.0	22.0				
Pedestrian Calls (#/hr)		0			0		0	0				
Act Effct Green (s)	9.0	40.2			27.2		27.5	27.5		7.0		41.2
Actuated g/C Ratio	0.10	0.45			0.31		0.31	0.31		0.08		0.47
v/c Ratio	0.86	0.49			0.71		0.85	0.80		0.95		0.67
Control Delay	64.1	19.8			29.4		46.2	31.9		87.1		12.9
Queue Delay	0.0	0.0			0.0		0.0	0.0		0.0		0.0
Total Delay	64.1	19.8			29.4		46.2	31.9		87.1		12.9
LOS	E	B			C		D	C		F		B
Approach Delay		38.4			29.4			36.7				35.3
Approach LOS		D			C			D				D

Intersection Summary

Area Type: Other

Cycle Length: 90

Actuated Cycle Length: 88.5

Natural Cycle: 90

Control Type: Actuated-Uncoordinated

Maximum v/c Ratio: 0.95

Intersection Signal Delay: 35.1

Intersection LOS: D

Intersection Capacity Utilization 90.6%

ICU Level of Service E

Analysis Period (min) 15

Splits and Phases: 10: US 101 NB Off Ramp/Lakewood Drive & Old Redwood Highway

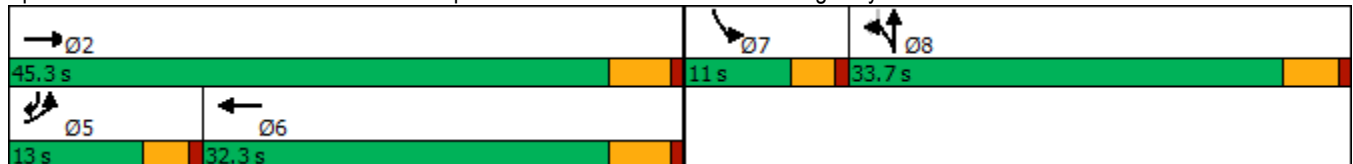

Lanes, Volumes, Timings  
 11: Old Redwood Highway & US 101 NB On Ramp

Existing Project Alter. C Conditions  
 Timing Plan: P.M. Peak

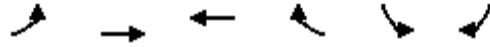

Lane Group	EBL	EBT	WBT	WBR	SBL	SBR
Lane Configurations	↖	↗↗	↖↖			
Traffic Volume (vph)	106	615	1403	169	0	0
Future Volume (vph)	106	615	1403	169	0	0
Ideal Flow (vphpl)	1900	1900	1900	1900	1900	1900
Storage Length (ft)	245			0	0	0
Storage Lanes	1			0	0	0
Taper Length (ft)	50				25	
Lane Util. Factor	1.00	0.95	0.95	0.95	1.00	1.00
Ped Bike Factor						
Frt			0.984			
Flt Protected	0.950					
Satd. Flow (prot)	1770	3539	3483	0	0	0
Flt Permitted	0.950					
Satd. Flow (perm)	1770	3539	3483	0	0	0
Link Speed (mph)		35	35		30	
Link Distance (ft)		531	226		299	
Travel Time (s)		10.3	4.4		6.8	
Confl. Peds. (#/hr)	17			17		
Confl. Bikes (#/hr)				8		
Peak Hour Factor	0.85	0.85	0.91	0.91	0.25	0.25
Adj. Flow (vph)	125	724	1542	186	0	0
Shared Lane Traffic (%)						
Lane Group Flow (vph)	125	724	1728	0	0	0
Enter Blocked Intersection	No	No	No	No	No	No
Lane Alignment	Left	Left	Left	Right	Left	Right
Median Width(ft)		12	12		0	
Link Offset(ft)		0	0		0	
Crosswalk Width(ft)		16	16		16	
Two way Left Turn Lane						
Headway Factor	1.00	1.00	1.00	1.00	1.00	1.00
Turning Speed (mph)	15			9	15	9
Sign Control		Free	Free		Free	

Intersection Summary	
Area Type:	Other
Control Type:	Unsignalized
Intersection Capacity Utilization	65.3% ICU Level of Service C
Analysis Period (min)	15

Lanes, Volumes, Timings

Existing Project Alter. C Conditions

12: US 101 SB On Ramp/US 101 SB Off Ramp & Old Redwood Highway

Timing Plan: P.M. Peak

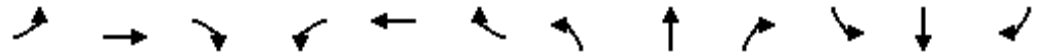

Lane Group	EBL	EBT	EBR	WBL	WBT	WBR	NBL	NBT	NBR	SBL	SBT	SBR
Lane Configurations		↑↑	↗	↖	↑↑					↖	↕	
Traffic Volume (vph)	0	535	381	381	1024	0	0	0	0	177	0	129
Future Volume (vph)	0	535	381	381	1024	0	0	0	0	177	0	129
Ideal Flow (vphpl)	1900	1900	1900	1900	1900	1900	1900	1900	1900	1900	1900	1900
Storage Length (ft)	0		0	250		0	0		0	420		0
Storage Lanes	0		1	0		0	0		0	1		0
Taper Length (ft)	25			165			25			75		
Lane Util. Factor	1.00	0.95	1.00	1.00	0.95	1.00	1.00	1.00	1.00	0.95	0.95	1.00
Ped Bike Factor			0.98	1.00								
Frt			0.850								0.868	
Flt Protected				0.950						0.950	0.994	
Satd. Flow (prot)	0	3539	1583	1770	3539	0	0	0	0	1681	1527	0
Flt Permitted				0.950						0.950	0.994	
Satd. Flow (perm)	0	3539	1558	1768	3539	0	0	0	0	1681	1527	0
Right Turn on Red			Yes			Yes			Yes			Yes
Satd. Flow (RTOR)			405								121	
Link Speed (mph)		35			35			30			30	
Link Distance (ft)		423			531			621			831	
Travel Time (s)		8.2			10.3			14.1			18.9	
Confl. Peds. (#/hr)	19		2	2		18						
Confl. Bikes (#/hr)			4			2						
Peak Hour Factor	0.94	0.94	0.94	0.89	0.89	0.89	0.25	0.25	0.25	0.83	0.83	0.83
Adj. Flow (vph)	0	569	405	428	1151	0	0	0	0	213	0	155
Shared Lane Traffic (%)										10%		
Lane Group Flow (vph)	0	569	405	428	1151	0	0	0	0	192	176	0
Enter Blocked Intersection	No	No	No	No	No	No	No	No	No	No	No	No
Lane Alignment	Left	Left	Right	Left	Left	Right	Left	Left	Right	Left	Left	Right
Median Width(ft)		24			24			12			12	
Link Offset(ft)		0			0			0			0	
Crosswalk Width(ft)		16			16			16			16	
Two way Left Turn Lane												
Headway Factor	1.00	1.00	1.00	1.00	1.00	1.00	1.00	1.00	1.00	1.00	1.00	1.00
Turning Speed (mph)	15		9	15		9	15		9	15		9
Number of Detectors		2	1	1	2					1	2	
Detector Template		Thru	Right	Left	Thru					Left	Thru	
Leading Detector (ft)		100	20	20	100					20	100	
Trailing Detector (ft)		0	0	0	0					0	0	
Detector 1 Position(ft)		0	0	0	0					0	0	
Detector 1 Size(ft)		6	20	20	6					20	6	
Detector 1 Type		Cl+Ex	Cl+Ex	Cl+Ex	Cl+Ex					Cl+Ex	Cl+Ex	
Detector 1 Channel												
Detector 1 Extend (s)		0.0	0.0	0.0	0.0					0.0	0.0	
Detector 1 Queue (s)		0.0	0.0	0.0	0.0					0.0	0.0	
Detector 1 Delay (s)		0.0	0.0	0.0	0.0					0.0	0.0	
Detector 2 Position(ft)		94			94							94
Detector 2 Size(ft)		6			6							6
Detector 2 Type		Cl+Ex			Cl+Ex							Cl+Ex
Detector 2 Channel												
Detector 2 Extend (s)		0.0			0.0							0.0



Lanes, Volumes, Timings

Existing Project Alter. C Conditions

12: US 101 SB On Ramp/US 101 SB Off Ramp & Old Redwood Highway

Timing Plan: P.M. Peak

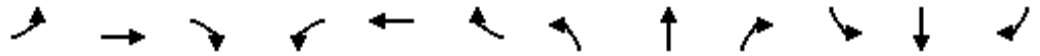

Lane Group	EBL	EBT	EBR	WBL	WBT	WBR	NBL	NBT	NBR	SBL	SBT	SBR
Turn Type		NA	Perm	Prot	NA					Perm	NA	
Protected Phases		6		5	2						8	
Permitted Phases			6							8		
Detector Phase		6	6	5	2					8	8	
Switch Phase												
Minimum Initial (s)		10.0	10.0	7.0	10.0					10.0	10.0	
Minimum Split (s)		32.1	32.1	11.0	38.1					14.7	14.7	
Total Split (s)		33.0	33.0	22.0	55.0					15.0	15.0	
Total Split (%)		47.1%	47.1%	31.4%	78.6%					21.4%	21.4%	
Maximum Green (s)		27.9	27.9	18.0	49.9					10.3	10.3	
Yellow Time (s)		4.1	4.1	3.0	4.1					3.7	3.7	
All-Red Time (s)		1.0	1.0	1.0	1.0					1.0	1.0	
Lost Time Adjust (s)		0.0	0.0	0.0	0.0					0.0	0.0	
Total Lost Time (s)		5.1	5.1	4.0	5.1					4.7	4.7	
Lead/Lag		Lag	Lag	Lead								
Lead-Lag Optimize?		Yes	Yes	Yes								
Vehicle Extension (s)		3.0	3.0	3.0	3.0					3.0	3.0	
Recall Mode		Max	Max	None	Max					None	None	
Walk Time (s)		7.0	7.0		7.0							
Flash Dont Walk (s)		20.0	20.0		25.0							
Pedestrian Calls (#/hr)		0	0		0							
Act Effct Green (s)		27.9	27.9	18.0	49.9					10.2	10.2	
Actuated g/C Ratio		0.40	0.40	0.26	0.71					0.15	0.15	
v/c Ratio		0.40	0.47	0.94	0.46					0.78	0.54	
Control Delay		16.1	3.7	58.1	5.0					52.8	17.2	
Queue Delay		0.0	0.0	0.0	0.0					0.0	0.0	
Total Delay		16.1	3.7	58.1	5.0					52.8	17.2	
LOS		B	A	E	A					D	B	
Approach Delay		11.0			19.3						35.8	
Approach LOS		B			B						D	

Intersection Summary

Area Type: Other  
 Cycle Length: 70  
 Actuated Cycle Length: 69.9  
 Natural Cycle: 70  
 Control Type: Actuated-Uncoordinated  
 Maximum v/c Ratio: 0.94  
 Intersection Signal Delay: 18.6  
 Intersection LOS: B  
 Intersection Capacity Utilization 65.3%  
 ICU Level of Service C  
 Analysis Period (min) 15

Splits and Phases: 12: US 101 SB On Ramp/US 101 SB Off Ramp & Old Redwood Highway

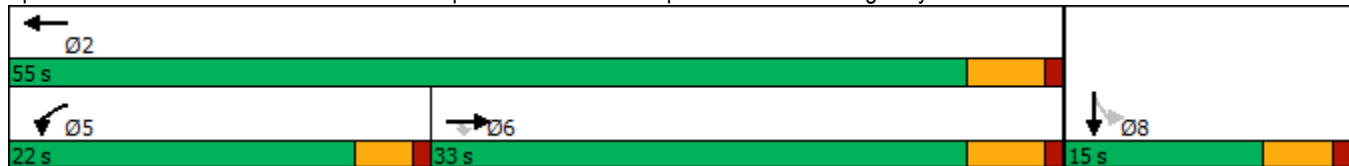

Lanes, Volumes, Timings  
1: Old Redwood Hwy & Shiloh Road

Existing Project Alter. C Conditions  
Timing Plan: Saturday Midday Peak

Lane Group	EBL	EBT	EBR	WBL	WBT	WBR	NBL	NBT	NBR	SBL	SBT	SBR
Lane Configurations												
Traffic Volume (vph)	123	175	170	21	188	30	177	233	24	34	187	180
Future Volume (vph)	123	175	170	21	188	30	177	233	24	34	187	180
Ideal Flow (vphpl)	1900	1900	1900	1900	1900	1900	1900	1900	1900	1900	1900	1900
Storage Length (ft)	375		140	0		50	200		98	130		93
Storage Lanes	1		1	0		1	1		1	1		1
Taper Length (ft)	50			25			60			93		
Lane Util. Factor	1.00	1.00	1.00	1.00	1.00	1.00	1.00	1.00	1.00	1.00	1.00	1.00
Ped Bike Factor	0.99		0.98						0.98			0.97
Flt			0.850			0.850			0.850			0.850
Flt Protected	0.950				0.995		0.950			0.950		
Satd. Flow (prot)	1770	1863	1583	0	1853	1583	1770	1863	1583	1770	1863	1583
Flt Permitted	0.950				0.995		0.950			0.950		
Satd. Flow (perm)	1761	1863	1549	0	1853	1583	1770	1863	1550	1770	1863	1540
Right Turn on Red			Yes			Yes			Yes			Yes
Satd. Flow (RTOR)			191			105			77			164
Link Speed (mph)		40			40			45			40	
Link Distance (ft)		1789			608			748			775	
Travel Time (s)		30.5			10.4			11.3			13.2	
Confl. Peds. (#/hr)	4											
Confl. Bikes (#/hr)			1						1			5
Peak Hour Factor	0.89	0.89	0.89	0.86	0.86	0.86	0.93	0.93	0.93	0.91	0.91	0.91
Adj. Flow (vph)	138	197	191	24	219	35	190	251	26	37	205	198
Shared Lane Traffic (%)												
Lane Group Flow (vph)	138	197	191	0	243	35	190	251	26	37	205	198
Enter Blocked Intersection	No	No	No	No	No	No	No	No	No	No	No	No
Lane Alignment	Left	Left	Right	Left	Left	Right	Left	Left	Right	Left	Left	Right
Median Width(ft)		12			12			12			12	
Link Offset(ft)		0			0			0			0	
Crosswalk Width(ft)		16			16			16			16	
Two way Left Turn Lane												
Headway Factor	1.00	1.00	1.00	1.00	1.00	1.00	1.00	1.00	1.00	1.00	1.00	1.00
Turning Speed (mph)	15		9	15		9	15		9	15		9
Number of Detectors	1	2	1	1	2	1	1	2	1	1	2	1
Detector Template	Left	Thru	Right	Left	Thru	Right	Left	Thru	Right	Left	Thru	Right
Leading Detector (ft)	20	100	20	20	100	20	20	100	20	20	100	20
Trailing Detector (ft)	0	0	0	0	0	0	0	0	0	0	0	0
Detector 1 Position(ft)	0	0	0	0	0	0	0	0	0	0	0	0
Detector 1 Size(ft)	20	6	20	20	6	20	20	6	20	20	6	20
Detector 1 Type	Cl+Ex	Cl+Ex	Cl+Ex	Cl+Ex	Cl+Ex	Cl+Ex	Cl+Ex	Cl+Ex	Cl+Ex	Cl+Ex	Cl+Ex	Cl+Ex
Detector 1 Channel												
Detector 1 Extend (s)	0.0	0.0	0.0	0.0	0.0	0.0	0.0	0.0	0.0	0.0	0.0	0.0
Detector 1 Queue (s)	0.0	0.0	0.0	0.0	0.0	0.0	0.0	0.0	0.0	0.0	0.0	0.0
Detector 1 Delay (s)	0.0	0.0	0.0	0.0	0.0	0.0	0.0	0.0	0.0	0.0	0.0	0.0
Detector 2 Position(ft)		94			94			94			94	
Detector 2 Size(ft)		6			6			6			6	
Detector 2 Type		Cl+Ex			Cl+Ex			Cl+Ex			Cl+Ex	
Detector 2 Channel												
Detector 2 Extend (s)		0.0			0.0			0.0			0.0	

Lanes, Volumes, Timings  
1: Old Redwood Hwy & Shiloh Road

Existing Project Alter. C Conditions  
Timing Plan: Saturday Midday Peak



Lane Group	EBL	EBT	EBR	WBL	WBT	WBR	NBL	NBT	NBR	SBL	SBT	SBR
Turn Type	Split	NA	Perm	Split	NA	Perm	Prot	NA	Perm	Prot	NA	Perm
Protected Phases	2	2		6	6		3	8		7	4	
Permitted Phases			2			6			8			4
Detector Phase	2	2	2	6	6	6	3	8	8	7	4	4
Switch Phase												
Minimum Initial (s)	5.0	5.0	5.0	5.0	5.0	5.0	5.0	5.0	5.0	5.0	5.0	5.0
Minimum Split (s)	34.5	34.5	34.5	42.5	42.5	42.5	8.5	46.5	46.5	8.5	39.5	39.5
Total Split (s)	35.0	35.0	35.0	42.5	42.5	42.5	18.0	48.0	48.0	9.5	39.5	39.5
Total Split (%)	25.9%	25.9%	25.9%	31.5%	31.5%	31.5%	13.3%	35.6%	35.6%	7.0%	29.3%	29.3%
Maximum Green (s)	30.5	30.5	30.5	38.0	38.0	38.0	14.5	43.5	43.5	6.0	35.0	35.0
Yellow Time (s)	3.5	3.5	3.5	3.5	3.5	3.5	3.0	3.5	3.5	3.0	3.5	3.5
All-Red Time (s)	1.0	1.0	1.0	1.0	1.0	1.0	0.5	1.0	1.0	0.5	1.0	1.0
Lost Time Adjust (s)	0.0	0.0	0.0		0.0	0.0	0.0	0.0	0.0	0.0	0.0	0.0
Total Lost Time (s)	4.5	4.5	4.5		4.5	4.5	3.5	4.5	4.5	3.5	4.5	4.5
Lead/Lag	Lead	Lead	Lead	Lag	Lag	Lag	Lead	Lag	Lag	Lead	Lag	Lag
Lead-Lag Optimize?	Yes	Yes	Yes	Yes	Yes	Yes	Yes	Yes	Yes	Yes	Yes	Yes
Vehicle Extension (s)	3.0	3.0	3.0	3.0	3.0	3.0	3.0	3.0	3.0	3.0	3.0	3.0
Recall Mode	None	None	None	None	None	None	None	None	None	None	None	None
Walk Time (s)	7.0	7.0	7.0	7.0	7.0	7.0		7.0	7.0		7.0	7.0
Flash Dont Walk (s)	23.0	23.0	23.0	31.0	31.0	31.0		35.0	35.0		28.0	28.0
Pedestrian Calls (#/hr)	0	0	0	0	0	0		0	0		0	0
Act Effct Green (s)	14.8	14.8	14.8		16.5	16.5	15.0	28.4	28.4	6.1	14.9	14.9
Actuated g/C Ratio	0.19	0.19	0.19		0.21	0.21	0.19	0.36	0.36	0.08	0.19	0.19
v/c Ratio	0.42	0.56	0.43		0.63	0.08	0.56	0.37	0.04	0.27	0.58	0.47
Control Delay	34.2	37.5	8.3		37.8	0.4	41.2	24.5	0.1	45.9	38.0	12.2
Queue Delay	0.0	0.0	0.0		0.0	0.0	0.0	0.0	0.0	0.0	0.0	0.0
Total Delay	34.2	37.5	8.3		37.8	0.4	41.2	24.5	0.1	45.9	38.0	12.2
LOS	C	D	A		D	A	D	C	A	D	D	B
Approach Delay		26.0			33.1			29.9			27.1	
Approach LOS		C			C			C			C	

Intersection Summary

Area Type:	Other
Cycle Length:	135
Actuated Cycle Length:	78.9
Natural Cycle:	135
Control Type:	Actuated-Uncoordinated
Maximum v/c Ratio:	0.63
Intersection Signal Delay:	28.5
Intersection LOS:	C
Intersection Capacity Utilization:	54.5%
ICU Level of Service:	A
Analysis Period (min):	15

Splits and Phases: 1: Old Redwood Hwy & Shiloh Road



Lanes, Volumes, Timings  
2: Shiloh Road & Hembree Ln

Existing Project Alter. C Conditions  
Timing Plan: Saturday Midday Peak



Lane Group	EBL	EBT	WBT	WBR	SBL	SBR
Lane Configurations	↶↶	↶	↶↶		↶	↷
Traffic Volume (vph)	622	380	346	159	160	580
Future Volume (vph)	622	380	346	159	160	580
Ideal Flow (vphp)	1900	1900	1900	1900	1900	1900
Storage Length (ft)	0			130	0	0
Storage Lanes	2			1	1	1
Taper Length (ft)	25				25	
Lane Util. Factor	0.97	1.00	0.95	0.95	1.00	1.00
Ped Bike Factor	1.00		1.00			
Frt			0.953			0.850
Flt Protected	0.950				0.950	
Satd. Flow (prot)	3433	1863	3359	0	1770	1583
Flt Permitted	0.950				0.950	
Satd. Flow (perm)	3431	1863	3359	0	1770	1583
Right Turn on Red				Yes		Yes
Satd. Flow (RTOR)			108			381
Link Speed (mph)		40	40		35	
Link Distance (ft)		302	1789		381	
Travel Time (s)		5.1	30.5		7.4	
Confl. Peds. (#/hr)	1			1		
Peak Hour Factor	0.94	0.94	0.96	0.96	0.91	0.91
Adj. Flow (vph)	662	404	360	166	176	637
Shared Lane Traffic (%)						
Lane Group Flow (vph)	662	404	526	0	176	637
Enter Blocked Intersection	No	No	No	No	No	No
Lane Alignment	Left	Left	Left	Right	Left	Right
Median Width(ft)		24	24		12	
Link Offset(ft)		0	0		0	
Crosswalk Width(ft)		16	16		16	
Two way Left Turn Lane						
Headway Factor	1.00	1.00	1.00	1.00	1.00	1.00
Turning Speed (mph)	15			9	15	9
Number of Detectors	1	2	2		1	1
Detector Template	Left	Thru	Thru		Left	Right
Leading Detector (ft)	20	100	100		20	20
Trailing Detector (ft)	0	0	0		0	0
Detector 1 Position(ft)	0	0	0		0	0
Detector 1 Size(ft)	20	6	6		20	20
Detector 1 Type	Cl+Ex	Cl+Ex	Cl+Ex		Cl+Ex	Cl+Ex
Detector 1 Channel						
Detector 1 Extend (s)	0.0	0.0	0.0		0.0	0.0
Detector 1 Queue (s)	0.0	0.0	0.0		0.0	0.0
Detector 1 Delay (s)	0.0	0.0	0.0		0.0	0.0
Detector 2 Position(ft)		94	94			
Detector 2 Size(ft)		6	6			
Detector 2 Type		Cl+Ex	Cl+Ex			
Detector 2 Channel						
Detector 2 Extend (s)		0.0	0.0			
Turn Type	Prot	NA	NA		Perm	pm+ov

Lanes, Volumes, Timings  
2: Shiloh Road & Hembree Ln

Existing Project Alter. C Conditions  
Timing Plan: Saturday Midday Peak

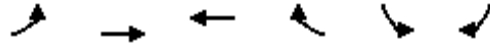

Lane Group	EBL	EBT	WBT	WBR	SBL	SBR
Protected Phases	5	2	6			5
Permitted Phases					4	4 5
Detector Phase	5	2	6		4	5
Switch Phase						
Minimum Initial (s)	3.0	5.0	5.0		5.0	3.0
Minimum Split (s)	7.0	9.0	43.0		9.0	7.0
Total Split (s)	29.0	73.0	44.0		17.0	29.0
Total Split (%)	32.2%	81.1%	48.9%		18.9%	32.2%
Maximum Green (s)	25.0	69.0	40.0		13.0	25.0
Yellow Time (s)	3.0	3.0	3.0		3.0	3.0
All-Red Time (s)	1.0	1.0	1.0		1.0	1.0
Lost Time Adjust (s)	0.0	0.0	0.0		0.0	0.0
Total Lost Time (s)	4.0	4.0	4.0		4.0	4.0
Lead/Lag	Lead		Lag			Lead
Lead-Lag Optimize?	Yes		Yes			Yes
Vehicle Extension (s)	3.0	3.0	3.0		3.0	3.0
Recall Mode	None	None	None		None	None
Walk Time (s)			7.0			
Flash Dont Walk (s)			32.0			
Pedestrian Calls (#/hr)			0			
Act Effct Green (s)	18.0	35.4	13.2		10.9	33.1
Actuated g/C Ratio	0.33	0.65	0.24		0.20	0.61
v/c Ratio	0.58	0.33	0.59		0.50	0.57
Control Delay	18.1	5.2	18.2		27.2	4.9
Queue Delay	0.0	0.0	0.0		0.0	0.0
Total Delay	18.1	5.2	18.2		27.2	4.9
LOS	B	A	B		C	A
Approach Delay		13.2	18.2		9.7	
Approach LOS		B	B		A	

Intersection Summary

Area Type:	Other
Cycle Length:	90
Actuated Cycle Length:	54.6
Natural Cycle:	75
Control Type:	Actuated-Uncoordinated
Maximum v/c Ratio:	0.59
Intersection Signal Delay:	13.1
Intersection LOS:	B
Intersection Capacity Utilization:	57.9%
ICU Level of Service:	B
Analysis Period (min):	15

Splits and Phases: 2: Shiloh Road & Hembree Ln

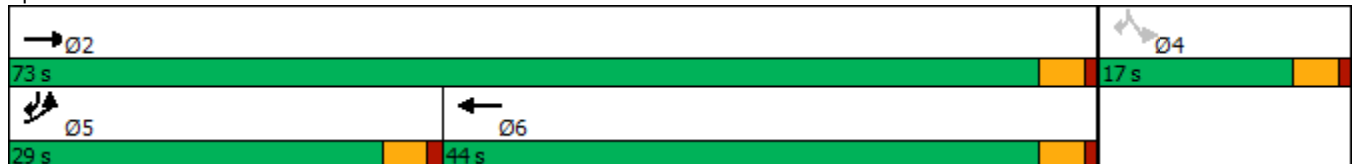

Lanes, Volumes, Timings  
3: US 101 NB Off-Ramp & Shiloh Road

Existing Project Alter. C Conditions  
Timing Plan: Saturday Midday Peak

	→	↘	↙	←	↖	↗
Lane Group	EBT	EBR	WBL	WBT	NBL	NBR
Lane Configurations	↑↑			↑	↘	↗
Traffic Volume (vph)	405	0	0	706	352	595
Future Volume (vph)	405	0	0	706	352	595
Ideal Flow (vphpl)	1900	1900	1900	1900	1900	1900
Storage Length (ft)		0	0		0	265
Storage Lanes		0	0		1	2
Taper Length (ft)			25		25	
Lane Util. Factor	0.95	1.00	1.00	1.00	1.00	0.88
Ped Bike Factor						
Frt						0.850
Flt Protected					0.950	
Satd. Flow (prot)	3539	0	0	1863	1770	2787
Flt Permitted					0.950	
Satd. Flow (perm)	3539	0	0	1863	1770	2787
Right Turn on Red		Yes				Yes
Satd. Flow (RTOR)						545
Link Speed (mph)	40			40	30	
Link Distance (ft)	186			371	769	
Travel Time (s)	3.2			6.3	17.5	
Confl. Bikes (#/hr)		1				
Peak Hour Factor	0.91	0.91	0.89	0.89	0.95	0.95
Adj. Flow (vph)	445	0	0	793	371	626
Shared Lane Traffic (%)						
Lane Group Flow (vph)	445	0	0	793	371	626
Enter Blocked Intersection	No	No	No	No	No	No
Lane Alignment	Left	Right	Left	Left	Left	Right
Median Width(ft)	0			0	12	
Link Offset(ft)	0			0	0	
Crosswalk Width(ft)	16			16	16	
Two way Left Turn Lane						
Headway Factor	1.00	1.00	1.00	1.00	1.00	1.00
Turning Speed (mph)		9	15		15	9
Number of Detectors	2			2	1	1
Detector Template	Thru			Thru	Left	Right
Leading Detector (ft)	100			100	20	20
Trailing Detector (ft)	0			0	0	0
Detector 1 Position(ft)	0			0	0	0
Detector 1 Size(ft)	6			6	20	20
Detector 1 Type	Cl+Ex			Cl+Ex	Cl+Ex	Cl+Ex
Detector 1 Channel						
Detector 1 Extend (s)	0.0			0.0	0.0	0.0
Detector 1 Queue (s)	0.0			0.0	0.0	0.0
Detector 1 Delay (s)	0.0			0.0	0.0	0.0
Detector 2 Position(ft)	94			94		
Detector 2 Size(ft)	6			6		
Detector 2 Type	Cl+Ex			Cl+Ex		
Detector 2 Channel						
Detector 2 Extend (s)	0.0			0.0		
Turn Type	NA			NA	Prot	Perm

Lanes, Volumes, Timings  
 3: US 101 NB Off-Ramp & Shiloh Road

Existing Project Alter. C Conditions  
 Timing Plan: Saturday Midday Peak



Lane Group	EBT	EBR	WBL	WBT	NBL	NBR
Protected Phases	2			6	8	
Permitted Phases						8
Detector Phase	2			6	8	8
Switch Phase						
Minimum Initial (s)	5.0			5.0	5.0	5.0
Minimum Split (s)	9.0			9.0	9.0	9.0
Total Split (s)	37.0			37.0	35.0	35.0
Total Split (%)	51.4%			51.4%	48.6%	48.6%
Maximum Green (s)	33.0			33.0	31.0	31.0
Yellow Time (s)	3.0			3.0	3.0	3.0
All-Red Time (s)	1.0			1.0	1.0	1.0
Lost Time Adjust (s)	0.0			0.0	0.0	0.0
Total Lost Time (s)	4.0			4.0	4.0	4.0
Lead/Lag						
Lead-Lag Optimize?						
Vehicle Extension (s)	3.0			3.0	3.0	3.0
Recall Mode	None			None	None	None
Act Effct Green (s)	29.3			29.3	18.4	18.4
Actuated g/C Ratio	0.52			0.52	0.33	0.33
v/c Ratio	0.24			0.82	0.64	0.49
Control Delay	8.6			21.7	22.0	4.0
Queue Delay	0.0			0.0	0.0	0.0
Total Delay	8.6			21.7	22.0	4.0
LOS	A			C	C	A
Approach Delay	8.6			21.7	10.7	
Approach LOS	A			C	B	

Intersection Summary

Area Type: Other  
 Cycle Length: 72  
 Actuated Cycle Length: 56.1  
 Natural Cycle: 50  
 Control Type: Actuated-Uncoordinated  
 Maximum v/c Ratio: 0.82  
 Intersection Signal Delay: 14.2  
 Intersection LOS: B  
 Intersection Capacity Utilization 96.7%  
 ICU Level of Service F  
 Analysis Period (min) 15

Splits and Phases: 3: US 101 NB Off-Ramp & Shiloh Road

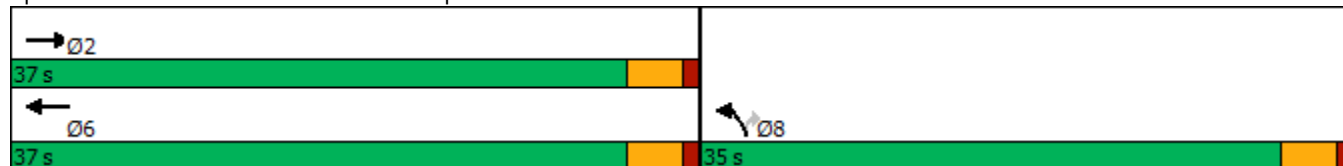

Lanes, Volumes, Timings  
4: Shiloh Road & US 101 SB Off-Ramp

Existing Project Alter. C Conditions  
Timing Plan: Saturday Midday Peak



Lane Group	EBL	EBT	WBT	WBR	SBL	SBR
Lane Configurations		↑	↑		↘	↘
Traffic Volume (vph)	0	273	525	0	211	151
Future Volume (vph)	0	273	525	0	211	151
Ideal Flow (vphp)	1900	1900	1900	1900	1900	1900
Storage Length (ft)	0			0	0	275
Storage Lanes	0			0	1	1
Taper Length (ft)	25				25	
Lane Util. Factor	1.00	1.00	1.00	1.00	1.00	1.00
Ped Bike Factor						
Frt						0.850
Flt Protected					0.950	
Satd. Flow (prot)	0	1863	1863	0	1770	1583
Flt Permitted					0.950	
Satd. Flow (perm)	0	1863	1863	0	1770	1583
Right Turn on Red				Yes		Yes
Satd. Flow (RTOR)						222
Link Speed (mph)		40	40		30	
Link Distance (ft)		225	306		486	
Travel Time (s)		3.8	5.2		11.0	
Confl. Bikes (#/hr)				2		
Peak Hour Factor	0.96	0.96	0.96	0.96	0.68	0.68
Adj. Flow (vph)	0	284	547	0	310	222
Shared Lane Traffic (%)						
Lane Group Flow (vph)	0	284	547	0	310	222
Enter Blocked Intersection	No	No	No	No	No	No
Lane Alignment	Left	Left	Left	Right	Left	Right
Median Width(ft)		4	0		12	
Link Offset(ft)		0	0		0	
Crosswalk Width(ft)		16	16		16	
Two way Left Turn Lane						
Headway Factor	1.00	1.00	1.00	1.00	1.00	1.00
Turning Speed (mph)	15			9	15	9
Number of Detectors		2	2		1	1
Detector Template		Thru	Thru		Left	Right
Leading Detector (ft)		100	100		20	20
Trailing Detector (ft)		0	0		0	0
Detector 1 Position(ft)		0	0		0	0
Detector 1 Size(ft)		6	6		20	20
Detector 1 Type		Cl+Ex	Cl+Ex		Cl+Ex	Cl+Ex
Detector 1 Channel						
Detector 1 Extend (s)		0.0	0.0		0.0	0.0
Detector 1 Queue (s)		0.0	0.0		0.0	0.0
Detector 1 Delay (s)		0.0	0.0		0.0	0.0
Detector 2 Position(ft)		94	94			
Detector 2 Size(ft)		6	6			
Detector 2 Type		Cl+Ex	Cl+Ex			
Detector 2 Channel						
Detector 2 Extend (s)		0.0	0.0			
Turn Type		NA	NA		Perm	Perm



Lanes, Volumes, Timings  
4: Shiloh Road & US 101 SB Off-Ramp

Existing Project Alter. C Conditions  
Timing Plan: Saturday Midday Peak



Lane Group	EBL	EBT	WBT	WBR	SBL	SBR
Protected Phases		2	6			
Permitted Phases					4	4
Detector Phase		2	6		4	4
Switch Phase						
Minimum Initial (s)		5.0	5.0		5.0	5.0
Minimum Split (s)		9.0	38.0		9.0	9.0
Total Split (s)		69.0	69.0		21.0	21.0
Total Split (%)		76.7%	76.7%		23.3%	23.3%
Maximum Green (s)		65.0	65.0		17.0	17.0
Yellow Time (s)		3.0	3.0		3.0	3.0
All-Red Time (s)		1.0	1.0		1.0	1.0
Lost Time Adjust (s)		0.0	0.0		0.0	0.0
Total Lost Time (s)		4.0	4.0		4.0	4.0
Lead/Lag						
Lead-Lag Optimize?						
Vehicle Extension (s)		3.0	3.0		3.0	3.0
Recall Mode		None	None		None	None
Walk Time (s)			7.0			
Flash Dont Walk (s)			27.0			
Pedestrian Calls (#/hr)			0			
Act Effct Green (s)		17.7	17.7		14.4	14.4
Actuated g/C Ratio		0.44	0.44		0.36	0.36
v/c Ratio		0.35	0.67		0.49	0.31
Control Delay		8.8	13.7		14.5	3.6
Queue Delay		0.0	0.0		0.0	0.0
Total Delay		8.8	13.7		14.5	3.6
LOS		A	B		B	A
Approach Delay		8.8	13.7		9.9	
Approach LOS		A	B		A	

Intersection Summary

Area Type:	Other
Cycle Length:	90
Actuated Cycle Length:	40.4
Natural Cycle:	55
Control Type:	Actuated-Uncoordinated
Maximum v/c Ratio:	0.67
Intersection Signal Delay:	11.2
Intersection LOS:	B
Intersection Capacity Utilization:	95.8%
ICU Level of Service:	F
Analysis Period (min):	15

Splits and Phases: 4: Shiloh Road & US 101 SB Off-Ramp



Lanes, Volumes, Timings  
5: Caletti Ave & Shiloh Road

Existing Project Alter. C Conditions  
Timing Plan: Saturday Midday Peak

	→	↘	↙	←	↖	↗
Lane Group	EBT	EBR	WBL	WBT	NBL	NBR
Lane Configurations	↑↑		↙	↑	↖	↗
Traffic Volume (vph)	545	20	81	604	16	78
Future Volume (vph)	545	20	81	604	16	78
Ideal Flow (vphpl)	1900	1900	1900	1900	1900	1900
Storage Length (ft)		0	68		0	0
Storage Lanes		0	1		1	1
Taper Length (ft)			50		25	
Lane Util. Factor	0.95	0.95	1.00	1.00	1.00	1.00
Ped Bike Factor						
Frt	0.995					0.850
Flt Protected			0.950		0.950	
Satd. Flow (prot)	3522	0	1770	1863	1770	1583
Flt Permitted			0.950		0.950	
Satd. Flow (perm)	3522	0	1770	1863	1770	1583
Link Speed (mph)	40			40	30	
Link Distance (ft)	1081			184	459	
Travel Time (s)	18.4			3.1	10.4	
Confl. Peds. (#/hr)					1	
Confl. Bikes (#/hr)		1				
Peak Hour Factor	0.92	0.92	0.87	0.87	0.78	0.78
Adj. Flow (vph)	592	22	93	694	21	100
Shared Lane Traffic (%)						
Lane Group Flow (vph)	614	0	93	694	21	100
Enter Blocked Intersection	No	No	No	No	No	No
Lane Alignment	Left	Right	Left	Left	Left	Right
Median Width(ft)	12			12	12	
Link Offset(ft)	0			0	0	
Crosswalk Width(ft)	16			16	16	
Two way Left Turn Lane						
Headway Factor	1.00	1.00	1.00	1.00	1.00	1.00
Turning Speed (mph)		9	15		15	9
Sign Control	Free			Free	Stop	

Intersection Summary

Area Type:	Other
Control Type:	Unsignalized
Intersection Capacity Utilization	41.8%
Analysis Period (min)	15
	ICU Level of Service A

Lanes, Volumes, Timings  
6: Conde Lane & Shiloh Road

Existing Project Alter. C Conditions  
Timing Plan: Saturday Midday Peak



Lane Group	EBL	EBT	EBR	WBL	WBT	WBR	NBL	NBT	NBR	SBL	SBT	SBR
Lane Configurations												
Traffic Volume (vph)	29	361	1	9	403	204	1	0	6	197	0	28
Future Volume (vph)	29	361	1	9	403	204	1	0	6	197	0	28
Ideal Flow (vphpl)	1900	1900	1900	1900	1900	1900	1900	1900	1900	1900	1900	1900
Storage Length (ft)	90		0	127		0	0		0	0		40
Storage Lanes	1		0	1		0	0		0	0		1
Taper Length (ft)	70			40			25			25		
Lane Util. Factor	1.00	0.95	0.95	1.00	0.95	0.95	1.00	1.00	1.00	1.00	1.00	1.00
Ped Bike Factor					0.99							
Frt					0.950			0.887				0.850
Flt Protected	0.950			0.950				0.992			0.950	
Satd. Flow (prot)	1770	3539	0	1770	3337	0	0	1639	0	0	1770	1583
Flt Permitted	0.950			0.950				0.992			0.950	
Satd. Flow (perm)	1770	3539	0	1770	3337	0	0	1639	0	0	1770	1583
Right Turn on Red			Yes			Yes			Yes			No
Satd. Flow (RTOR)					92			89				
Link Speed (mph)		40			40			30				35
Link Distance (ft)		815			1081			418				522
Travel Time (s)		13.9			18.4			9.5				10.2
Confl. Bikes (#/hr)						2						
Peak Hour Factor	0.96	0.96	0.96	0.91	0.91	0.91	0.58	0.58	0.58	0.78	0.78	0.78
Adj. Flow (vph)	30	376	1	10	443	224	2	0	10	253	0	36
Shared Lane Traffic (%)												
Lane Group Flow (vph)	30	377	0	10	667	0	0	12	0	0	253	36
Enter Blocked Intersection	No	No	No	No	No	No	No	No	No	No	No	No
Lane Alignment	Left	Left	Right	Left	Left	Right	Left	Left	Right	Left	Left	Right
Median Width(ft)		12			12			0				0
Link Offset(ft)		0			0			0				0
Crosswalk Width(ft)		16			16			16				16
Two way Left Turn Lane												
Headway Factor	1.00	1.00	1.00	1.00	1.00	1.00	1.00	1.00	1.00	1.00	1.00	1.00
Turning Speed (mph)	15		9	15		9	15		9	15		9
Number of Detectors	1	2		1	2		1	2		1	1	1
Detector Template	Left	Thru		Left	Thru		Left	Thru		Left	Thru	Right
Leading Detector (ft)	20	100		20	100		20	100		20	30	20
Trailing Detector (ft)	0	0		0	0		0	0		0	0	0
Detector 1 Position(ft)	0	0		0	0		0	0		0	0	0
Detector 1 Size(ft)	20	6		20	6		20	6		20	30	20
Detector 1 Type	Cl+Ex	Cl+Ex		Cl+Ex	Cl+Ex		Cl+Ex	Cl+Ex		Cl+Ex	Cl+Ex	Cl+Ex
Detector 1 Channel												
Detector 1 Extend (s)	0.0	0.0		0.0	0.0		0.0	0.0		0.0	0.0	0.0
Detector 1 Queue (s)	0.0	0.0		0.0	0.0		0.0	0.0		0.0	0.0	0.0
Detector 1 Delay (s)	0.0	0.0		0.0	0.0		0.0	0.0		0.0	0.0	0.0
Detector 2 Position(ft)		94			94			94				
Detector 2 Size(ft)		6			6			6				
Detector 2 Type		Cl+Ex			Cl+Ex			Cl+Ex				
Detector 2 Channel												
Detector 2 Extend (s)		0.0			0.0			0.0				
Turn Type	Prot	NA		Prot	NA		Split	NA		Split	NA	custom

Lanes, Volumes, Timings  
6: Conde Lane & Shiloh Road

Existing Project Alter. C Conditions  
Timing Plan: Saturday Midday Peak

Lane Group	EBL	EBT	EBR	WBL	WBT	WBR	NBL	NBT	NBR	SBL	SBT	SBR
Protected Phases	5	2		1	6		7	7		4	4	
Permitted Phases												6
Detector Phase	5	2		1	6		7	7		4	4	6
Switch Phase												
Minimum Initial (s)	8.0	8.0		8.0	8.0		10.0	10.0		11.0	11.0	8.0
Minimum Split (s)	12.0	46.0		12.0	12.0		37.0	37.0		15.0	15.0	12.0
Total Split (s)	13.0	46.0		12.0	45.0		37.0	37.0		15.0	15.0	45.0
Total Split (%)	11.8%	41.8%		10.9%	40.9%		33.6%	33.6%		13.6%	13.6%	40.9%
Maximum Green (s)	9.0	42.0		8.0	41.0		33.0	33.0		11.0	11.0	41.0
Yellow Time (s)	3.0	3.0		3.0	3.0		3.0	3.0		3.0	3.0	3.0
All-Red Time (s)	1.0	1.0		1.0	1.0		1.0	1.0		1.0	1.0	1.0
Lost Time Adjust (s)	0.0	0.0		0.0	0.0		0.0	0.0		0.0	0.0	0.0
Total Lost Time (s)	4.0	4.0		4.0	4.0		4.0	4.0		4.0	4.0	4.0
Lead/Lag	Lead	Lag		Lead	Lag							Lag
Lead-Lag Optimize?	Yes	Yes		Yes	Yes							Yes
Vehicle Extension (s)	3.0	3.0		3.0	3.0		3.0	3.0		3.0	3.0	3.0
Recall Mode	None	None		None	None		None	None		None	None	None
Walk Time (s)		7.0					7.0	7.0				
Flash Dont Walk (s)		35.0					26.0	26.0				
Pedestrian Calls (#/hr)		0					0	0				
Act Effct Green (s)	9.0	14.5		8.9	14.5		11.1	11.1		12.3	12.3	14.5
Actuated g/C Ratio	0.23	0.38		0.23	0.38		0.29	0.29		0.32	0.32	0.38
v/c Ratio	0.07	0.28		0.02	0.51		0.02	0.02		0.45	0.45	0.06
Control Delay	18.9	10.2		19.2	10.6		0.1	0.1		20.7	20.7	10.5
Queue Delay	0.0	0.0		0.0	0.0		0.0	0.0		0.0	0.0	0.0
Total Delay	18.9	10.2		19.2	10.6		0.1	0.1		20.7	20.7	10.5
LOS	B	B		B	B		A	A		C	C	B
Approach Delay		10.9			10.7		0.1	0.1		19.4	19.4	
Approach LOS		B			B		A	A		B	B	

Intersection Summary





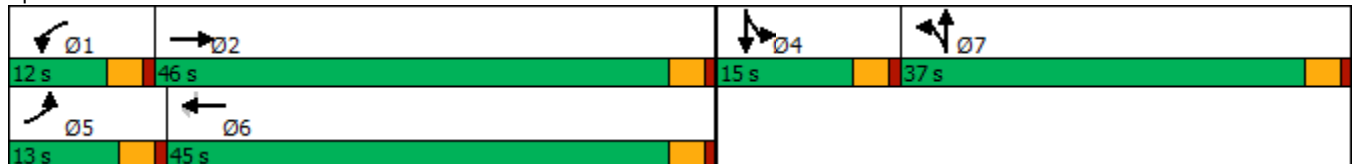











Area Type:	Other
Cycle Length:	110
Actuated Cycle Length:	38.6
Natural Cycle:	110
Control Type:	Actuated-Uncoordinated
Maximum v/c Ratio:	0.51
Intersection Signal Delay:	12.5
Intersection LOS:	B
Intersection Capacity Utilization:	48.3%
ICU Level of Service:	A
Analysis Period (min):	15

Splits and Phases: 6: Conde Lane & Shiloh Road



Lanes, Volumes, Timings  
7: Entrance 1/Gridley Drive & Shiloh Road

Existing Project Alter. C Conditions  
Timing Plan: Saturday Midday Peak

												
Lane Group	EBL	EBT	EBR	WBL	WBT	WBR	NBL	NBT	NBR	SBL	SBT	SBR
Lane Configurations												
Traffic Volume (vph)	20	106	118	8	92	0	133	0	9	0	0	18
Future Volume (vph)	20	106	118	8	92	0	133	0	9	0	0	18
Ideal Flow (vphpl)	1900	1900	1900	1900	1900	1900	1900	1900	1900	1900	1900	1900
Lane Util. Factor	1.00	1.00	1.00	1.00	1.00	1.00	1.00	1.00	1.00	1.00	1.00	1.00
Ped Bike Factor												
Frt		0.935						0.850			0.865	
Flt Protected		0.996			0.996		0.950					
Satd. Flow (prot)	0	1735	0	0	1855	0	1770	1583	0	0	1611	0
Flt Permitted		0.996			0.996		0.950					
Satd. Flow (perm)	0	1735	0	0	1855	0	1770	1583	0	0	1611	0
Link Speed (mph)		40			40			30			30	
Link Distance (ft)		608			2146			248			715	
Travel Time (s)		10.4			36.6			5.6			16.3	
Confl. Peds. (#/hr)	1											
Confl. Bikes (#/hr)			1			3						
Peak Hour Factor	0.93	0.93	0.93	0.88	0.88	0.88	1.00	1.00	1.00	0.56	0.56	0.56
Adj. Flow (vph)	22	114	127	9	105	0	133	0	9	0	0	32
Shared Lane Traffic (%)												
Lane Group Flow (vph)	0	263	0	0	114	0	133	9	0	0	32	0
Enter Blocked Intersection	No	No	No	No	No	No	No	No	No	No	No	No
Lane Alignment	Left	Left	Right	Left	Left	Right	Left	Left	Right	Left	Left	Right
Median Width(ft)		0			0			12			12	
Link Offset(ft)		0			0			0			0	
Crosswalk Width(ft)		16			16			16			16	
Two way Left Turn Lane												
Headway Factor	1.00	1.00	1.00	1.00	1.00	1.00	1.00	1.00	1.00	1.00	1.00	1.00
Turning Speed (mph)	15		9	15		9	15		9	15		9
Sign Control		Free			Free			Stop			Stop	
<b>Intersection Summary</b>												
Area Type:	Other											
Control Type:	Unsignalized											
Intersection Capacity Utilization	39.0%						ICU Level of Service A					
Analysis Period (min)	15											

Lanes, Volumes, Timings  
8: Old Redwood Hwy & Entrance 1

Existing Project Alter. C Conditions  
Timing Plan: Saturday Midday Peak













Lane Group	EBL	EBT	EBR	WBL	WBT	WBR	NBL	NBT	NBR	SBL	SBT	SBR
Lane Configurations		↕		↖	↗			↕		↖	↗	
Traffic Volume (vph)	1	0	2	19	0	31	1	403	17	27	342	4
Future Volume (vph)	1	0	2	19	0	31	1	403	17	27	342	4
Ideal Flow (vphpl)	1900	1900	1900	1900	1900	1900	1900	1900	1900	1900	1900	1900
Storage Length (ft)	0		0	0		0	0		0	50		0
Storage Lanes	0		0	1		0	0		0	1		0
Taper Length (ft)	25			25			25			25		
Lane Util. Factor	1.00	1.00	1.00	1.00	1.00	1.00	1.00	1.00	1.00	1.00	1.00	1.00
Ped Bike Factor												
Frt		0.916			0.850			0.995			0.998	
Flt Protected		0.982		0.950						0.950		
Satd. Flow (prot)	0	1676	0	1770	1583	0	0	1853	0	1770	1859	0
Flt Permitted		0.982		0.950						0.950		
Satd. Flow (perm)	0	1676	0	1770	1583	0	0	1853	0	1770	1859	0
Link Speed (mph)		30			30			45			45	
Link Distance (ft)		98			385			520			748	
Travel Time (s)		2.2			8.8			7.9			11.3	
Confl. Peds. (#/hr)							1		4	4		1
Confl. Bikes (#/hr)									3			9
Peak Hour Factor	0.38	0.38	0.38	1.00	1.00	1.00	0.94	0.94	0.94	0.93	0.93	0.93
Adj. Flow (vph)	3	0	5	19	0	31	1	429	18	29	368	4
Shared Lane Traffic (%)												
Lane Group Flow (vph)	0	8	0	19	31	0	0	448	0	29	372	0
Enter Blocked Intersection	No	No	No	No	No	No	No	No	No	No	No	No
Lane Alignment	Left	Left	Right	Left	Left	Right	Left	Left	Right	Left	Left	Right
Median Width(ft)		12			12			12			12	
Link Offset(ft)		0			0			0			0	
Crosswalk Width(ft)		16			16			16			16	
Two way Left Turn Lane												
Headway Factor	1.00	1.00	1.00	1.00	1.00	1.00	1.00	1.00	1.00	1.00	1.00	1.00
Turning Speed (mph)	15		9	15		9	15		9	15		9
Sign Control		Stop			Stop			Free			Free	

**Intersection Summary**  
 Area Type: Other  
 Control Type: Unsignalized  
 Intersection Capacity Utilization 33.1%      ICU Level of Service A  
 Analysis Period (min) 15

Lanes, Volumes, Timings  
9: Entrance 2 & Shiloh Road

Existing Project Alter. C Conditions  
Timing Plan: Saturday Midday Peak

						
Lane Group	EBT	EBR	WBL	WBT	NBL	NBR
Lane Configurations						
Traffic Volume (vph)	101	0	0	94	0	0
Future Volume (vph)	101	0	0	94	0	0
Ideal Flow (vphpl)	1900	1900	1900	1900	1900	1900
Lane Util. Factor	1.00	1.00	1.00	1.00	1.00	1.00
Ped Bike Factor						
Frt						
Flt Protected						
Satd. Flow (prot)	1863	0	0	1863	1863	1863
Flt Permitted						
Satd. Flow (perm)	1863	0	0	1863	1863	1863
Link Speed (mph)	40			40	30	
Link Distance (ft)	2146			134	402	
Travel Time (s)	36.6			2.3	9.1	
Confl. Peds. (#/hr)		1				
Peak Hour Factor	0.88	0.88	0.80	0.80	1.00	1.00
Adj. Flow (vph)	115	0	0	118	0	0
Shared Lane Traffic (%)						
Lane Group Flow (vph)	115	0	0	118	0	0
Enter Blocked Intersection	No	No	No	No	No	No
Lane Alignment	Left	Right	Left	Left	Left	Right
Median Width(ft)	0			0	12	
Link Offset(ft)	0			0	0	
Crosswalk Width(ft)	16			16	16	
Two way Left Turn Lane						
Headway Factor	1.00	1.00	1.00	1.00	1.00	1.00
Turning Speed (mph)		9	15		15	9
Sign Control	Free			Free	Stop	
<b>Intersection Summary</b>						
Area Type:	Other					
Control Type:	Unsignalized					
Intersection Capacity Utilization	8.9%			ICU Level of Service A		
Analysis Period (min)	15					

Lanes, Volumes, Timings

Existing Project Alter. C Conditions

10: US 101 NB Off Ramp/Lakewood Drive & Old Redwood Highway Timing Plan: Saturday Midday Peak



Lane Group	EBL	EBT	EBR	WBL	WBT	WBR	NBL	NBT	NBR	SBL	SBT	SBR
Lane Configurations												
Traffic Volume (vph)	252	292	0	0	460	242	281	266	125	214	0	615
Future Volume (vph)	252	292	0	0	460	242	281	266	125	214	0	615
Ideal Flow (vphpl)	1900	1900	1900	1900	1900	1900	1900	1900	1900	1900	1900	1900
Storage Length (ft)	155		0	0		0	270		150	120		0
Storage Lanes	1		0	0		0	1		1	1		1
Taper Length (ft)	50			25			165			75		
Lane Util. Factor	0.97	1.00	1.00	1.00	0.95	0.95	0.91	0.91	0.95	0.97	1.00	1.00
Ped Bike Factor	1.00				0.99			1.00		1.00		
Fr <sub>t</sub>					0.948			0.958				0.850
Fl <sub>t</sub> Protected	0.950						0.950	0.994		0.950		
Satd. Flow (prot)	3433	1863	0	0	3336	0	1610	3217	0	3433	0	1583
Fl <sub>t</sub> Permitted	0.950						0.950	0.994		0.950		
Satd. Flow (perm)	3429	1863	0	0	3336	0	1610	3217	0	3430	0	1583
Right Turn on Red			Yes			Yes			Yes			Yes
Satd. Flow (RTOR)					111			61				314
Link Speed (mph)		35			35			30				30
Link Distance (ft)		226			617			716				478
Travel Time (s)		4.4			12.0			16.3				10.9
Confl. Peds. (#/hr)	2		1	1		2			1	1		
Confl. Bikes (#/hr)			10			3						
Peak Hour Factor	0.95	0.95	0.95	0.89	0.89	0.89	0.98	0.98	0.98	0.88	0.88	0.88
Adj. Flow (vph)	265	307	0	0	517	272	287	271	128	243	0	699
Shared Lane Traffic (%)							20%					
Lane Group Flow (vph)	265	307	0	0	789	0	230	456	0	243	0	699
Enter Blocked Intersection	No	No	No	No	No	No	No	No	No	No	No	No
Lane Alignment	Left	Left	Right	Left	Left	Right	Left	Left	Right	Left	Left	Right
Median Width(ft)		24			24			24				24
Link Offset(ft)		0			0			0				0
Crosswalk Width(ft)		16			16			16				16
Two way Left Turn Lane												
Headway Factor	1.00	1.00	1.00	1.00	1.00	1.00	1.00	1.00	1.00	1.00	1.00	1.00
Turning Speed (mph)	15		9	15		9	15		9	15		9
Number of Detectors	1	2			2		1	2		1		1
Detector Template	Left	Thru			Thru		Left	Thru		Left		Right
Leading Detector (ft)	20	100			100		20	100		20		20
Trailing Detector (ft)	0	0			0		0	0		0		0
Detector 1 Position(ft)	0	0			0		0	0		0		0
Detector 1 Size(ft)	20	6			6		20	6		20		20
Detector 1 Type	Cl+Ex	Cl+Ex			Cl+Ex		Cl+Ex	Cl+Ex		Cl+Ex		Cl+Ex
Detector 1 Channel												
Detector 1 Extend (s)	0.0	0.0			0.0		0.0	0.0		0.0		0.0
Detector 1 Queue (s)	0.0	0.0			0.0		0.0	0.0		0.0		0.0
Detector 1 Delay (s)	0.0	0.0			0.0		0.0	0.0		0.0		0.0
Detector 2 Position(ft)		94			94			94				
Detector 2 Size(ft)		6			6			6				
Detector 2 Type		Cl+Ex			Cl+Ex			Cl+Ex				
Detector 2 Channel												
Detector 2 Extend (s)		0.0			0.0			0.0				



Lanes, Volumes, Timings

Existing Project Alter. C Conditions

10: US 101 NB Off Ramp/Lakewood Drive & Old Redwood Highway Timing Plan: Saturday Midday Peak



Lane Group	EBL	EBT	EBR	WBL	WBT	WBR	NBL	NBT	NBR	SBL	SBT	SBR
Turn Type	Prot	NA			NA		Split	NA		Prot		pm+ov
Protected Phases	5	2			6		8	8		7		5
Permitted Phases												5 8
Detector Phase	5	2			6		8	8		7		5
Switch Phase												
Minimum Initial (s)	7.0	10.0			10.0		10.0	10.0		7.0		7.0
Minimum Split (s)	11.0	32.1			32.1		33.7	33.7		11.0		11.0
Total Split (s)	12.0	45.3			33.3		33.7	33.7		11.0		12.0
Total Split (%)	13.3%	50.3%			37.0%		37.4%	37.4%		12.2%		13.3%
Maximum Green (s)	8.0	40.2			28.2		29.0	29.0		7.0		8.0
Yellow Time (s)	3.0	4.1			4.1		3.7	3.7		3.0		3.0
All-Red Time (s)	1.0	1.0			1.0		1.0	1.0		1.0		1.0
Lost Time Adjust (s)	0.0	0.0			0.0		0.0	0.0		0.0		0.0
Total Lost Time (s)	4.0	5.1			5.1		4.7	4.7		4.0		4.0
Lead/Lag	Lead				Lag		Lag	Lag		Lead		Lead
Lead-Lag Optimize?	Yes				Yes		Yes	Yes		Yes		Yes
Vehicle Extension (s)	3.0	3.0			3.0		3.0	3.0		3.0		3.0
Recall Mode	None	Max			Max		None	None		None		None
Walk Time (s)		7.0			7.0		7.0	7.0				
Flash Dont Walk (s)		20.0			17.0		22.0	22.0				
Pedestrian Calls (#/hr)		0			0		0	0				
Act Effct Green (s)	8.0	40.4			28.4		18.0	18.0		7.0		30.8
Actuated g/C Ratio	0.10	0.51			0.36		0.23	0.23		0.09		0.39
v/c Ratio	0.76	0.32			0.62		0.63	0.59		0.80		0.87
Control Delay	52.0	13.9			21.5		35.3	26.2		57.8		24.5
Queue Delay	0.0	0.0			0.0		0.0	0.0		0.0		0.0
Total Delay	52.0	13.9			21.5		35.3	26.2		57.8		24.5
LOS	D	B			C		D	C		E		C
Approach Delay		31.5			21.5			29.3				33.1
Approach LOS		C			C			C				C

Intersection Summary

Area Type: Other  
 Cycle Length: 90  
 Actuated Cycle Length: 79.4  
 Natural Cycle: 90  
 Control Type: Actuated-Uncoordinated  
 Maximum v/c Ratio: 0.87  
 Intersection Signal Delay: 28.8  
 Intersection LOS: C  
 Intersection Capacity Utilization 83.5%  
 ICU Level of Service E  
 Analysis Period (min) 15

Splits and Phases: 10: US 101 NB Off Ramp/Lakewood Drive & Old Redwood Highway

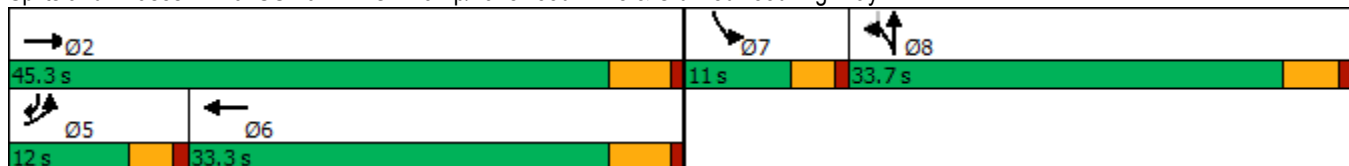

Lanes, Volumes, Timings  
 11: Old Redwood Highway & US 101 NB On Ramp

Existing Project Alter. C Conditions  
 Timing Plan: Saturday Midday Peak

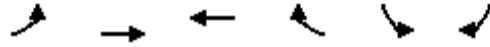

Lane Group	EBL	EBT	WBT	WBR	SBL	SBR
Lane Configurations						
Traffic Volume (vph)	76	548	1150	189	0	0
Future Volume (vph)	76	548	1150	189	0	0
Ideal Flow (vphpl)	1900	1900	1900	1900	1900	1900
Storage Length (ft)	245			0	0	0
Storage Lanes	1			0	0	0
Taper Length (ft)	50				25	
Lane Util. Factor	1.00	0.95	0.95	0.95	1.00	1.00
Ped Bike Factor						
Frt			0.979			
Flt Protected	0.950					
Satd. Flow (prot)	1770	3539	3465	0	0	0
Flt Permitted	0.950					
Satd. Flow (perm)	1770	3539	3465	0	0	0
Link Speed (mph)		35	35		30	
Link Distance (ft)		531	226		299	
Travel Time (s)		10.3	4.4		6.8	
Confl. Peds. (#/hr)	8			8		
Confl. Bikes (#/hr)				4		
Peak Hour Factor	0.96	0.96	0.92	0.92	0.25	0.25
Adj. Flow (vph)	79	571	1250	205	0	0
Shared Lane Traffic (%)						
Lane Group Flow (vph)	79	571	1455	0	0	0
Enter Blocked Intersection	No	No	No	No	No	No
Lane Alignment	Left	Left	Left	Right	Left	Right
Median Width(ft)		12	12		0	
Link Offset(ft)		0	0		0	
Crosswalk Width(ft)		16	16		16	
Two way Left Turn Lane						
Headway Factor	1.00	1.00	1.00	1.00	1.00	1.00
Turning Speed (mph)	15			9	15	9
Sign Control		Free	Free		Free	

Intersection Summary	
Area Type:	Other
Control Type:	Unsignalized
Intersection Capacity Utilization	66.6% ICU Level of Service C
Analysis Period (min)	15

Lanes, Volumes, Timings

Existing Project Alter. C Conditions

12: US 101 SB On Ramp/US 101 SB Off Ramp & Old Redwood Highway Timing Plan: Saturday Midday Peak



Lane Group	EBL	EBT	EBR	WBL	WBT	WBR	NBL	NBT	NBR	SBL	SBT	SBR
Lane Configurations		↑↑	↗	↖	↑↑					↖	↕	
Traffic Volume (vph)	0	483	368	428	718	0	0	0	0	150	1	76
Future Volume (vph)	0	483	368	428	718	0	0	0	0	150	1	76
Ideal Flow (vphpl)	1900	1900	1900	1900	1900	1900	1900	1900	1900	1900	1900	1900
Storage Length (ft)	0		0	250		0	0		0	420		0
Storage Lanes	0		1	0		0	0		0	1		0
Taper Length (ft)	25			165			25			75		
Lane Util. Factor	1.00	0.95	1.00	1.00	0.95	1.00	1.00	1.00	1.00	0.95	0.95	1.00
Ped Bike Factor			0.98	1.00								
Frt			0.850								0.895	
Flt Protected				0.950						0.950	0.986	
Satd. Flow (prot)	0	3539	1583	1770	3539	0	0	0	0	1681	1562	0
Flt Permitted				0.950						0.950	0.986	
Satd. Flow (perm)	0	3539	1553	1768	3539	0	0	0	0	1681	1562	0
Right Turn on Red			Yes			Yes			Yes			Yes
Satd. Flow (RTOR)			379								106	
Link Speed (mph)		35			35			30			30	
Link Distance (ft)		423			531			621			831	
Travel Time (s)		8.2			10.3			14.1			18.9	
Confl. Peds. (#/hr)	11		2	2		11						
Confl. Bikes (#/hr)			10			2						
Peak Hour Factor	0.97	0.97	0.97	0.96	0.96	0.96	0.25	0.25	0.25	0.72	0.72	0.72
Adj. Flow (vph)	0	498	379	446	748	0	0	0	0	208	1	106
Shared Lane Traffic (%)										21%		
Lane Group Flow (vph)	0	498	379	446	748	0	0	0	0	164	151	0
Enter Blocked Intersection	No	No	No	No	No	No	No	No	No	No	No	No
Lane Alignment	Left	Left	Right	Left	Left	Right	Left	Left	Right	Left	Left	Right
Median Width(ft)		24			24			12			12	
Link Offset(ft)		0			0			0			0	
Crosswalk Width(ft)		16			16			16			16	
Two way Left Turn Lane												
Headway Factor	1.00	1.00	1.00	1.00	1.00	1.00	1.00	1.00	1.00	1.00	1.00	1.00
Turning Speed (mph)	15		9	15		9	15		9	15		9
Number of Detectors		2	1	1	2					1	2	
Detector Template		Thru	Right	Left	Thru					Left	Thru	
Leading Detector (ft)		100	20	20	100					20	100	
Trailing Detector (ft)		0	0	0	0					0	0	
Detector 1 Position(ft)		0	0	0	0					0	0	
Detector 1 Size(ft)		6	20	20	6					20	6	
Detector 1 Type		Cl+Ex	Cl+Ex	Cl+Ex	Cl+Ex					Cl+Ex	Cl+Ex	
Detector 1 Channel												
Detector 1 Extend (s)		0.0	0.0	0.0	0.0					0.0	0.0	
Detector 1 Queue (s)		0.0	0.0	0.0	0.0					0.0	0.0	
Detector 1 Delay (s)		0.0	0.0	0.0	0.0					0.0	0.0	
Detector 2 Position(ft)		94			94							94
Detector 2 Size(ft)		6			6							6
Detector 2 Type		Cl+Ex			Cl+Ex							Cl+Ex
Detector 2 Channel												
Detector 2 Extend (s)		0.0			0.0							0.0

Lanes, Volumes, Timings

Existing Project Alter. C Conditions

12: US 101 SB On Ramp/US 101 SB Off Ramp & Old Redwood Highway Timing Plan: Saturday Midday Peak



Lane Group	EBL	EBT	EBR	WBL	WBT	WBR	NBL	NBT	NBR	SBL	SBT	SBR
Turn Type		NA	Perm	Prot	NA					Perm	NA	
Protected Phases		6		5	2						8	
Permitted Phases			6							8		
Detector Phase		6	6	5	2					8	8	
Switch Phase												
Minimum Initial (s)		10.0	10.0	7.0	10.0					10.0	10.0	
Minimum Split (s)		32.1	32.1	11.0	38.1					14.7	14.7	
Total Split (s)		32.3	32.3	23.0	55.3					14.7	14.7	
Total Split (%)		46.1%	46.1%	32.9%	79.0%					21.0%	21.0%	
Maximum Green (s)		27.2	27.2	19.0	50.2					10.0	10.0	
Yellow Time (s)		4.1	4.1	3.0	4.1					3.7	3.7	
All-Red Time (s)		1.0	1.0	1.0	1.0					1.0	1.0	
Lost Time Adjust (s)		0.0	0.0	0.0	0.0					0.0	0.0	
Total Lost Time (s)		5.1	5.1	4.0	5.1					4.7	4.7	
Lead/Lag		Lag	Lag	Lead								
Lead-Lag Optimize?		Yes	Yes	Yes								
Vehicle Extension (s)		3.0	3.0	3.0	3.0					3.0	3.0	
Recall Mode		Max	Max	None	Max					None	None	
Walk Time (s)		7.0	7.0		7.0							
Flash Dont Walk (s)		20.0	20.0		25.0							
Pedestrian Calls (#/hr)		0	0		0							
Act Effct Green (s)		27.3	27.3	18.9	50.2					10.0	10.0	
Actuated g/C Ratio		0.39	0.39	0.27	0.72					0.14	0.14	
v/c Ratio		0.36	0.45	0.94	0.29					0.68	0.48	
Control Delay		16.1	3.8	55.6	3.9					45.2	16.1	
Queue Delay		0.0	0.0	0.0	0.0					0.0	0.0	
Total Delay		16.1	3.8	55.6	3.9					45.2	16.1	
LOS		B	A	E	A					D	B	
Approach Delay		10.8			23.2							31.3
Approach LOS		B			C							C

Intersection Summary

Area Type: Other  
 Cycle Length: 70  
 Actuated Cycle Length: 70  
 Natural Cycle: 70  
 Control Type: Actuated-Uncoordinated  
 Maximum v/c Ratio: 0.94  
 Intersection Signal Delay: 19.7  
 Intersection LOS: B  
 Intersection Capacity Utilization 66.6%  
 ICU Level of Service C  
 Analysis Period (min) 15



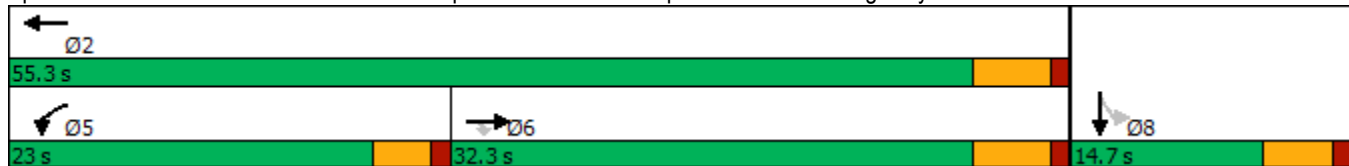



















Splits and Phases: 12: US 101 SB On Ramp/US 101 SB Off Ramp & Old Redwood Highway



Appendix F – Opening Year 2028 Conditions Intersection Level of  
Service Worksheets

























HCM 6th Signalized Intersection Summary  
 1: Old Redwood Hwy & Shiloh Road

2028 Opening Year No Project Conditions  
 Timing Plan: A.M. PEAK

												
Movement	EBL	EBT	EBR	WBL	WBT	WBR	NBL	NBT	NBR	SBL	SBT	SBR
Lane Configurations												
Traffic Volume (veh/h)	137	120	96	25	61	13	93	142	39	15	263	208
Future Volume (veh/h)	137	120	96	25	61	13	93	142	39	15	263	208
Initial Q (Qb), veh	0	0	0	0	0	0	0	0	0	0	0	0
Ped-Bike Adj(A_pbT)	1.00		1.00	1.00		1.00	1.00		1.00	1.00		0.98
Parking Bus, Adj	1.00	1.00	1.00	1.00	1.00	1.00	1.00	1.00	1.00	1.00	1.00	1.00
Work Zone On Approach		No			No			No			No	
Adj Sat Flow, veh/h/ln	1870	1870	1870	1870	1870	1870	1870	1870	1870	1870	1870	1870
Adj Flow Rate, veh/h	169	148	119	28	69	15	100	153	42	18	309	245
Peak Hour Factor	0.81	0.81	0.81	0.89	0.89	0.89	0.93	0.93	0.93	0.85	0.85	0.85
Percent Heavy Veh, %	2	2	2	2	2	2	2	2	2	2	2	2
Cap, veh/h	299	314	266	45	111	134	197	467	396	201	472	391
Arrive On Green	0.17	0.17	0.17	0.08	0.08	0.08	0.11	0.25	0.25	0.11	0.25	0.25
Sat Flow, veh/h	1781	1870	1585	532	1312	1585	1781	1870	1585	1781	1870	1551
Grp Volume(v), veh/h	169	148	119	97	0	15	100	153	42	18	309	245
Grp Sat Flow(s),veh/h/ln	1781	1870	1585	1844	0	1585	1781	1870	1585	1781	1870	1551
Q Serve(g_s), s	3.9	3.2	3.0	2.2	0.0	0.4	2.3	3.0	0.9	0.4	6.5	6.2
Cycle Q Clear(g_c), s	3.9	3.2	3.0	2.2	0.0	0.4	2.3	3.0	0.9	0.4	6.5	6.2
Prop In Lane	1.00		1.00	0.29		1.00	1.00		1.00	1.00		1.00
Lane Grp Cap(c), veh/h	299	314	266	156	0	134	197	467	396	201	472	391
V/C Ratio(X)	0.56	0.47	0.45	0.62	0.00	0.11	0.51	0.33	0.11	0.09	0.65	0.63
Avail Cap(c_a), veh/h	1229	1290	1094	1585	0	1362	584	1840	1560	242	1481	1228
HCM Platoon Ratio	1.00	1.00	1.00	1.00	1.00	1.00	1.00	1.00	1.00	1.00	1.00	1.00
Upstream Filter(I)	1.00	1.00	1.00	1.00	0.00	1.00	1.00	1.00	1.00	1.00	1.00	1.00
Uniform Delay (d), s/veh	16.9	16.6	16.5	19.6	0.0	18.7	18.5	13.5	12.8	17.6	14.8	14.7
Incr Delay (d2), s/veh	1.7	1.1	1.2	4.0	0.0	0.4	2.0	0.4	0.1	0.2	1.5	1.6
Initial Q Delay(d3),s/veh	0.0	0.0	0.0	0.0	0.0	0.0	0.0	0.0	0.0	0.0	0.0	0.0
%ile BackOfQ(50%),veh/ln	1.4	1.2	0.9	1.0	0.0	0.1	0.9	1.0	0.3	0.1	2.4	1.9
Unsig. Movement Delay, s/veh												
LnGrp Delay(d),s/veh	18.6	17.7	17.7	23.6	0.0	19.1	20.5	14.0	12.9	17.8	16.4	16.3
LnGrp LOS	B	B	B	C	A	B	C	B	B	B	B	B
Approach Vol, veh/h		436			112			295			572	
Approach Delay, s/veh		18.0			23.0			16.0			16.4	
Approach LOS		B			C			B			B	
Timer - Assigned Phs		2	3	4		6	7	8				
Phs Duration (G+Y+Rc), s		11.9	8.4	15.7		8.2	8.5	15.5				
Change Period (Y+Rc), s		4.5	3.5	4.5		4.5	3.5	4.5				
Max Green Setting (Gmax), s		30.5	14.5	35.0		38.0	6.0	43.5				
Max Q Clear Time (g_c+I1), s		5.9	4.3	8.5		4.2	2.4	5.0				
Green Ext Time (p_c), s		1.6	0.1	2.6		0.5	0.0	0.9				
<b>Intersection Summary</b>												
HCM 6th Ctrl Delay				17.3								
HCM 6th LOS				B								

HCM 6th Signalized Intersection Summary  
2: Shiloh Road & Hembree Ln

2028 Opening Year No Project Conditions  
Timing Plan: A.M. PEAK

												
Movement	EBL	EBT	EBR	WBL	WBT	WBR	NBL	NBT	NBR	SBL	SBT	SBR
Lane Configurations	 			 	 						 	 
Traffic Volume (veh/h)	347	302	38	19	320	82	39	7	11	81	9	413
Future Volume (veh/h)	347	302	38	19	320	82	39	7	11	81	9	413
Initial Q (Qb), veh	0	0	0	0	0	0	0	0	0	0	0	0
Ped-Bike Adj(A_pbT)	1.00		1.00	1.00		1.00	1.00		1.00	1.00		1.00
Parking Bus, Adj	1.00	1.00	1.00	1.00	1.00	1.00	1.00	1.00	1.00	1.00	1.00	1.00
Work Zone On Approach		No			No			No			No	
Adj Sat Flow, veh/h/ln	1870	1870	1870	1870	1870	1870	1870	1870	1870	1870	1870	1870
Adj Flow Rate, veh/h	394	343	38	19	330	85	39	7	11	86	9	439
Peak Hour Factor	0.88	0.88	1.00	1.00	0.97	0.97	1.00	1.00	1.00	0.94	1.00	0.94
Percent Heavy Veh, %	2	2	2	2	2	2	2	2	2	2	2	2
Cap, veh/h	592	583	65	42	574	146	100	37	58	354	37	618
Arrive On Green	0.17	0.35	0.35	0.02	0.20	0.20	0.06	0.06	0.06	0.22	0.22	0.22
Sat Flow, veh/h	3456	1654	183	1781	2806	713	1781	655	1030	1620	170	1585
Grp Volume(v), veh/h	394	0	381	19	207	208	39	0	18	95	0	439
Grp Sat Flow(s),veh/h/ln	1728	0	1837	1781	1777	1742	1781	0	1685	1789	0	1585
Q Serve(g_s), s	4.9	0.0	7.8	0.5	4.8	4.9	1.0	0.0	0.5	2.0	0.0	10.0
Cycle Q Clear(g_c), s	4.9	0.0	7.8	0.5	4.8	4.9	1.0	0.0	0.5	2.0	0.0	10.0
Prop In Lane	1.00		0.10	1.00		0.41	1.00		0.61	0.91		1.00
Lane Grp Cap(c), veh/h	592	0	648	42	364	357	100	0	95	391	0	618
V/C Ratio(X)	0.67	0.00	0.59	0.46	0.57	0.58	0.39	0.00	0.19	0.24	0.00	0.71
Avail Cap(c_a), veh/h	1283	0	2127	214	1610	1579	214	0	202	391	0	618
HCM Platoon Ratio	1.00	1.00	1.00	1.00	1.00	1.00	1.00	1.00	1.00	1.00	1.00	1.00
Upstream Filter(I)	1.00	0.00	1.00	1.00	1.00	1.00	1.00	0.00	1.00	1.00	0.00	1.00
Uniform Delay (d), s/veh	17.7	0.0	12.1	22.1	16.4	16.4	20.8	0.0	20.6	14.8	0.0	11.8
Incr Delay (d2), s/veh	1.3	0.0	0.9	7.5	1.4	1.5	2.4	0.0	1.0	0.3	0.0	3.8
Initial Q Delay(d3),s/veh	0.0	0.0	0.0	0.0	0.0	0.0	0.0	0.0	0.0	0.0	0.0	0.0
%ile BackOfQ(50%),veh/ln	1.7	0.0	2.5	0.3	1.7	1.8	0.4	0.0	0.2	0.7	0.0	3.6
Unsig. Movement Delay, s/veh												
LnGrp Delay(d),s/veh	19.0	0.0	13.0	29.6	17.8	18.0	23.3	0.0	21.6	15.1	0.0	15.6
LnGrp LOS	B	A	B	C	B	B	C	A	C	B	A	B
Approach Vol, veh/h		775			434			57				534
Approach Delay, s/veh		16.1			18.4			22.7				15.5
Approach LOS		B			B			C				B
Timer - Assigned Phs	1	2		4	5	6		8				
Phs Duration (G+Y+Rc), s	5.1	20.1		14.0	11.8	13.4		6.6				
Change Period (Y+Rc), s	4.0	4.0		4.0	4.0	4.0		4.0				
Max Green Setting (Gmax), s	5.5	53.0		10.0	17.0	41.5		5.5				
Max Q Clear Time (g_c+I1), s	2.5	9.8		12.0	6.9	6.9		3.0				
Green Ext Time (p_c), s	0.0	2.4		0.0	1.0	2.4		0.0				
<b>Intersection Summary</b>												
HCM 6th Ctrl Delay				16.7								
HCM 6th LOS				B								

HCM 6th Signalized Intersection Summary  
 3: US 101 NB Off-Ramp & Shiloh Road

2028 Opening Year No Project Conditions  
 Timing Plan: A.M. PEAK



Movement	EBT	EBR	WBL	WBT	NBL	NBR
Lane Configurations	↑↑			↑	↘	↗
Traffic Volume (veh/h)	276	0	0	614	492	427
Future Volume (veh/h)	276	0	0	614	492	427
Initial Q (Qb), veh	0	0	0	0	0	0
Ped-Bike Adj(A_pbT)		1.00	1.00		1.00	1.00
Parking Bus, Adj	1.00	1.00	1.00	1.00	1.00	1.00
Work Zone On Approach	No			No	No	
Adj Sat Flow, veh/h/ln	1870	0	0	1870	1870	1870
Adj Flow Rate, veh/h	303	0	0	682	647	562
Peak Hour Factor	0.91	0.91	0.90	0.90	0.76	0.76
Percent Heavy Veh, %	2	0	0	2	2	2
Cap, veh/h	1520	0	0	800	765	1197
Arrive On Green	0.43	0.00	0.00	0.43	0.43	0.43
Sat Flow, veh/h	3741	0	0	1870	1781	2790
Grp Volume(v), veh/h	303	0	0	682	647	562
Grp Sat Flow(s),veh/h/ln	1777	0	0	1870	1781	1395
Q Serve(g_s), s	3.0	0.0	0.0	18.4	18.2	8.1
Cycle Q Clear(g_c), s	3.0	0.0	0.0	18.4	18.2	8.1
Prop In Lane		0.00	0.00		1.00	1.00
Lane Grp Cap(c), veh/h	1520	0	0	800	765	1197
V/C Ratio(X)	0.20	0.00	0.00	0.85	0.85	0.47
Avail Cap(c_a), veh/h	2097	0	0	1104	988	1547
HCM Platoon Ratio	1.00	1.00	1.00	1.00	1.00	1.00
Upstream Filter(I)	1.00	0.00	0.00	1.00	1.00	1.00
Uniform Delay (d), s/veh	10.0	0.0	0.0	14.4	14.3	11.4
Incr Delay (d2), s/veh	0.1	0.0	0.0	4.9	5.5	0.3
Initial Q Delay(d3),s/veh	0.0	0.0	0.0	0.0	0.0	0.0
%ile BackOfQ(50%),veh/ln	0.9	0.0	0.0	7.0	7.3	2.2
Unsig. Movement Delay, s/veh						
LnGrp Delay(d),s/veh	10.1	0.0	0.0	19.3	19.8	11.7
LnGrp LOS	B	A	A	B	B	B
Approach Vol, veh/h	303			682	1209	
Approach Delay, s/veh	10.1			19.3	16.0	
Approach LOS	B			B	B	
Timer - Assigned Phs		2			6	8
Phs Duration (G+Y+Rc), s		27.9			27.9	28.0
Change Period (Y+Rc), s		4.0			4.0	4.0
Max Green Setting (Gmax), s		33.0			33.0	31.0
Max Q Clear Time (g_c+I1), s		5.0			20.4	20.2
Green Ext Time (p_c), s		1.9			3.6	3.8
<b>Intersection Summary</b>						
HCM 6th Ctrl Delay			16.2			
HCM 6th LOS			B			



HCM Signalized Intersection Capacity Analysis  
4: Shiloh Road & US 101 SB Off-Ramp

2028 Opening Year No Project Conditions

Timing Plan: A.M. PEAK



Movement	EBL	EBT	WBT	WBR	SBL	SBR
Lane Configurations		↑	↑		↘	↗
Traffic Volume (vph)	0	267	676	0	92	174
Future Volume (vph)	0	267	676	0	92	174
Ideal Flow (vphpl)	1900	1900	1900	1900	1900	1900
Total Lost time (s)		4.0	4.0		4.0	4.0
Lane Util. Factor		1.00	1.00		1.00	1.00
Frt		1.00	1.00		1.00	0.85
Flt Protected		1.00	1.00		0.95	1.00
Satd. Flow (prot)		1863	1863		1770	1583
Flt Permitted		1.00	1.00		0.95	1.00
Satd. Flow (perm)		1863	1863		1770	1583
Peak-hour factor, PHF	0.93	0.93	0.91	0.91	0.92	0.92
Adj. Flow (vph)	0	287	743	0	100	189
RTOR Reduction (vph)	0	0	0	0	0	158
Lane Group Flow (vph)	0	287	743	0	100	31
Turn Type		NA	NA		Perm	Perm
Protected Phases		2	6			
Permitted Phases					4	4
Actuated Green, G (s)		22.3	22.3		6.0	6.0
Effective Green, g (s)		22.3	22.3		6.0	6.0
Actuated g/C Ratio		0.61	0.61		0.17	0.17
Clearance Time (s)		4.0	4.0		4.0	4.0
Vehicle Extension (s)		3.0	3.0		3.0	3.0
Lane Grp Cap (vph)		1144	1144		292	261
v/s Ratio Prot		0.15	c0.40			
v/s Ratio Perm					c0.06	0.02
v/c Ratio		0.25	0.65		0.34	0.12
Uniform Delay, d1		3.2	4.5		13.4	12.9
Progression Factor		1.00	1.00		1.00	1.00
Incremental Delay, d2		0.1	1.3		0.7	0.2
Delay (s)		3.3	5.8		14.1	13.1
Level of Service		A	A		B	B
Approach Delay (s)		3.3	5.8		13.5	
Approach LOS		A	A		B	

Intersection Summary			
HCM 2000 Control Delay	6.9	HCM 2000 Level of Service	A
HCM 2000 Volume to Capacity ratio	0.58		
Actuated Cycle Length (s)	36.3	Sum of lost time (s)	8.0
Intersection Capacity Utilization	63.0%	ICU Level of Service	B
Analysis Period (min)	15		

c Critical Lane Group

Intersection						
Int Delay, s/veh	2.9					
Movement	EBT	EBR	WBL	WBT	NBL	NBR
Lane Configurations	↑↑		↘	↑	↘	↘
Traffic Vol, veh/h	590	25	202	623	8	138
Future Vol, veh/h	590	25	202	623	8	138
Conflicting Peds, #/hr	0	0	0	0	0	0
Sign Control	Free	Free	Free	Free	Stop	Stop
RT Channelized	-	None	-	None	-	None
Storage Length	-	-	68	-	0	0
Veh in Median Storage, #	0	-	-	0	0	-
Grade, %	0	-	-	0	0	-
Peak Hour Factor	96	96	87	87	84	84
Heavy Vehicles, %	2	2	2	2	2	2
Mvmt Flow	615	26	232	716	10	164

Major/Minor	Major1	Major2	Minor1	Minor2	Minor3
Conflicting Flow All	0	0	641	0	1808
Stage 1	-	-	-	-	628
Stage 2	-	-	-	-	1180
Critical Hdwy	-	-	4.13	-	6.63
Critical Hdwy Stg 1	-	-	-	-	5.83
Critical Hdwy Stg 2	-	-	-	-	5.43
Follow-up Hdwy	-	-	2.219	-	3.519
Pot Cap-1 Maneuver	-	-	941	-	78
Stage 1	-	-	-	-	495
Stage 2	-	-	-	-	291
Platoon blocked, %	-	-	-	-	-
Mov Cap-1 Maneuver	-	-	941	-	59
Mov Cap-2 Maneuver	-	-	-	-	59
Stage 1	-	-	-	-	495
Stage 2	-	-	-	-	219



















Approach	EB	WB	NB
HCM Control Delay, s	0	2.5	15.6
HCM LOS			C

Minor Lane/Major Mvmt	NBLn1	NBLn2	EBT	EBR	WBL	WBT
Capacity (veh/h)	59	675	-	-	941	-
HCM Lane V/C Ratio	0.161	0.243	-	-	0.247	-
HCM Control Delay (s)	77.4	12	-	-	10.1	-
HCM Lane LOS	F	B	-	-	B	-
HCM 95th %tile Q(veh)	0.5	1	-	-	1	-

HCM Signalized Intersection Capacity Analysis  
 6: Conde Lane & Shiloh Road

2028 Opening Year No Project Conditions

Timing Plan: A.M. PEAK

													
Movement	EBL	EBT	EBR	WBL	WBT	WBR	NBL	NBT	NBR	SBL	SBT	SBR	
Lane Configurations													
Traffic Volume (vph)	28	368	6	10	400	232	5	0	14	233	1	40	
Future Volume (vph)	28	368	6	10	400	232	5	0	14	233	1	40	
Ideal Flow (vphpl)	1900	1900	1900	1900	1900	1900	1900	1900	1900	1900	1900	1900	
Total Lost time (s)	4.0	4.0		4.0	4.0			4.0			4.0	4.0	
Lane Util. Factor	1.00	0.95		1.00	0.95			1.00			1.00	1.00	
Frt	1.00	1.00		1.00	0.94			0.90			1.00	0.85	
Flt Protected	0.95	1.00		0.95	1.00			0.99			0.95	1.00	
Satd. Flow (prot)	1770	3531		1770	3344			1656			1774	1583	
Flt Permitted	0.95	1.00		0.95	1.00			0.99			0.95	1.00	
Satd. Flow (perm)	1770	3531		1770	3344			1656			1774	1583	
Peak-hour factor, PHF	0.95	0.95	0.95	0.85	0.85	0.85	0.57	0.57	0.57	0.86	0.86	0.86	
Adj. Flow (vph)	29	387	6	12	471	273	9	0	25	271	1	47	
RTOR Reduction (vph)	0	1	0	0	78	0	0	32	0	0	0	0	
Lane Group Flow (vph)	29	392	0	12	666	0	0	2	0	0	272	47	
Turn Type	Prot	NA		Prot	NA		Split	NA		Split	NA	custom	
Protected Phases	5	2		1	6		7	7		4	4		
Permitted Phases												6	
Actuated Green, G (s)	2.2	19.5		1.0	18.3			2.7			12.8	18.3	
Effective Green, g (s)	2.2	19.5		1.0	18.3			2.7			12.8	18.3	
Actuated g/C Ratio	0.04	0.38		0.02	0.35			0.05			0.25	0.35	
Clearance Time (s)	4.0	4.0		4.0	4.0			4.0			4.0	4.0	
Vehicle Extension (s)	3.0	3.0		3.0	3.0			3.0			3.0	3.0	
Lane Grp Cap (vph)	74	1324		34	1176			85			436	557	
v/s Ratio Prot	c0.02	0.11		0.01	c0.20			c0.00			c0.15		
v/s Ratio Perm												0.03	
v/c Ratio	0.39	0.30		0.35	0.57			0.02			0.62	0.08	
Uniform Delay, d1	24.2	11.4		25.2	13.6			23.4			17.5	11.3	
Progression Factor	1.00	1.00		1.00	1.00			1.00			1.00	1.00	
Incremental Delay, d2	3.4	0.1		6.2	0.6			0.1			2.8	0.1	
Delay (s)	27.7	11.5		31.4	14.3			23.5			20.2	11.3	
Level of Service	C	B		C	B			C			C	B	
Approach Delay (s)		12.7			14.5			23.5			18.9		
Approach LOS		B			B			C			B		

Intersection Summary		
HCM 2000 Control Delay	15.1	HCM 2000 Level of Service
HCM 2000 Volume to Capacity ratio	0.53	B
Actuated Cycle Length (s)	52.0	Sum of lost time (s)
Intersection Capacity Utilization	49.6%	16.0
Analysis Period (min)	15	ICU Level of Service
		A

c Critical Lane Group

Intersection												
Int Delay, s/veh	1.1											
Movement	EBL	EBT	EBR	WBL	WBT	WBR	NBL	NBT	NBR	SBL	SBT	SBR
Lane Configurations		↕			↕		↕	↕			↕	
Traffic Vol, veh/h	9	161	0	0	66	0	0	0	0	1	0	18
Future Vol, veh/h	9	161	0	0	66	0	0	0	0	1	0	18
Conflicting Peds, #/hr	0	0	0	0	0	0	0	0	0	0	0	0
Sign Control	Free	Free	Free	Free	Free	Free	Stop	Stop	Stop	Stop	Stop	Stop
RT Channelized	-	-	None	-	-	None	-	-	None	-	-	None
Storage Length	-	-	-	-	-	-	0	-	-	-	-	-
Veh in Median Storage, #	-	0	-	-	0	-	-	0	-	-	0	-
Grade, %	-	0	-	-	0	-	-	0	-	-	0	-
Peak Hour Factor	91	91	91	85	85	85	100	100	100	71	71	71
Heavy Vehicles, %	2	2	2	2	2	2	2	2	2	2	2	2
Mvmt Flow	10	177	0	0	78	0	0	0	0	1	0	25

Major/Minor	Major1			Major2			Minor1			Minor2		
Conflicting Flow All	78	0	0	177	0	0	288	275	177	275	275	78
Stage 1	-	-	-	-	-	-	197	197	-	78	78	-
Stage 2	-	-	-	-	-	-	91	78	-	197	197	-
Critical Hdwy	4.12	-	-	4.12	-	-	7.12	6.52	6.22	7.12	6.52	6.22
Critical Hdwy Stg 1	-	-	-	-	-	-	6.12	5.52	-	6.12	5.52	-
Critical Hdwy Stg 2	-	-	-	-	-	-	6.12	5.52	-	6.12	5.52	-
Follow-up Hdwy	2.218	-	-	2.218	-	-	3.518	4.018	3.318	3.518	4.018	3.318
Pot Cap-1 Maneuver	1520	-	-	1399	-	-	664	632	866	677	632	983
Stage 1	-	-	-	-	-	-	805	738	-	931	830	-
Stage 2	-	-	-	-	-	-	916	830	-	805	738	-
Platoon blocked, %		-	-		-	-						
Mov Cap-1 Maneuver	1520	-	-	1399	-	-	643	628	866	674	628	983
Mov Cap-2 Maneuver	-	-	-	-	-	-	643	628	-	674	628	-
Stage 1	-	-	-	-	-	-	799	733	-	924	830	-
Stage 2	-	-	-	-	-	-	892	830	-	799	733	-

Approach	EB	WB	NB	SB
HCM Control Delay, s	0.4	0	0	8.9
HCM LOS			A	A

Minor Lane/Major Mvmt	NBLn1	NBLn2	EBL	EBT	EBR	WBL	WBT	WBR	SBLn1
Capacity (veh/h)	-	-	1520	-	-	1399	-	-	960
HCM Lane V/C Ratio	-	-	0.007	-	-	-	-	-	0.028
HCM Control Delay (s)	0	0	7.4	0	-	0	-	-	8.9
HCM Lane LOS	A	A	A	A	-	A	-	-	A
HCM 95th %tile Q(veh)	-	-	0	-	-	0	-	-	0.1

Intersection												
Int Delay, s/veh	0.1											
Movement	EBL	EBT	EBR	WBL	WBT	WBR	NBL	NBT	NBR	SBL	SBT	SBR
Lane Configurations		↕		↕	↕			↕		↕	↕	
Traffic Vol, veh/h	1	0	0	0	0	0	0	247	0	0	360	0
Future Vol, veh/h	1	0	0	0	0	0	0	247	0	0	360	0
Conflicting Peds, #/hr	0	0	0	0	0	0	0	0	1	1	0	0
Sign Control	Stop	Stop	Stop	Stop	Stop	Stop	Free	Free	Free	Free	Free	Free
RT Channelized	-	-	None	-	-	None	-	-	None	-	-	None
Storage Length	-	-	-	0	-	-	-	-	-	50	-	-
Veh in Median Storage, #	-	0	-	-	0	-	-	0	-	-	0	-
Grade, %	-	0	-	-	0	-	-	0	-	-	0	-
Peak Hour Factor	25	25	25	100	100	100	99	99	99	90	90	90
Heavy Vehicles, %	2	2	2	2	2	2	2	2	2	2	2	2
Mvmt Flow	4	0	0	0	0	0	0	249	0	0	400	0

Major/Minor	Minor2		Minor1		Major1		Major2					
Conflicting Flow All	649	650	400	650	650	250	400	0	0	250	0	0
Stage 1	400	400	-	250	250	-	-	-	-	-	-	-
Stage 2	249	250	-	400	400	-	-	-	-	-	-	-
Critical Hdwy	7.12	6.52	6.22	7.12	6.52	6.22	4.12	-	-	4.12	-	-
Critical Hdwy Stg 1	6.12	5.52	-	6.12	5.52	-	-	-	-	-	-	-
Critical Hdwy Stg 2	6.12	5.52	-	6.12	5.52	-	-	-	-	-	-	-
Follow-up Hdwy	3.518	4.018	3.318	3.518	4.018	3.318	2.218	-	-	2.218	-	-
Pot Cap-1 Maneuver	383	388	650	382	388	789	1159	-	-	1316	-	-
Stage 1	626	602	-	754	700	-	-	-	-	-	-	-
Stage 2	755	700	-	626	602	-	-	-	-	-	-	-
Platoon blocked, %								-	-	-	-	-
Mov Cap-1 Maneuver	383	388	650	382	388	788	1159	-	-	1315	-	-
Mov Cap-2 Maneuver	383	388	-	382	388	-	-	-	-	-	-	-
Stage 1	626	602	-	753	699	-	-	-	-	-	-	-
Stage 2	755	699	-	626	602	-	-	-	-	-	-	-

Approach	EB	WB	NB	SB
HCM Control Delay, s	14.5	0	0	0
HCM LOS	B	A		

Minor Lane/Major Mvmt	NBL	NBT	NBR	EBLn1	WBLn1	WBLn2	SBL	SBT	SBR
Capacity (veh/h)	1159	-	-	383	-	-	1315	-	-
HCM Lane V/C Ratio	-	-	-	0.01	-	-	-	-	-
HCM Control Delay (s)	0	-	-	14.5	0	0	0	-	-
HCM Lane LOS	A	-	-	B	A	A	A	-	-
HCM 95th %tile Q(veh)	0	-	-	0	-	-	0	-	-

Intersection						
Int Delay, s/veh	0					
Movement	EBT	EBR	WBL	WBT	NBL	NBR
Lane Configurations	↔			↔	↔	↔
Traffic Vol, veh/h	159	0	0	59	0	0
Future Vol, veh/h	159	0	0	59	0	0
Conflicting Peds, #/hr	0	0	0	0	0	0
Sign Control	Free	Free	Free	Free	Stop	Stop
RT Channelized	-	None	-	None	-	None
Storage Length	-	-	-	-	0	0
Veh in Median Storage, #	0	-	-	0	0	-
Grade, %	0	-	-	0	0	-
Peak Hour Factor	85	85	81	81	100	100
Heavy Vehicles, %	2	2	2	2	2	2
Mvmt Flow	187	0	0	73	0	0

Major/Minor	Major1	Major2	Minor1		
Conflicting Flow All	0	0	187	0	260
Stage 1	-	-	-	-	187
Stage 2	-	-	-	-	73
Critical Hdwy	-	-	4.12	-	6.42
Critical Hdwy Stg 1	-	-	-	-	5.42
Critical Hdwy Stg 2	-	-	-	-	5.42
Follow-up Hdwy	-	-	2.218	-	3.518
Pot Cap-1 Maneuver	-	-	1387	-	729
Stage 1	-	-	-	-	845
Stage 2	-	-	-	-	950
Platoon blocked, %	-	-	-	-	-
Mov Cap-1 Maneuver	-	-	1387	-	729
Mov Cap-2 Maneuver	-	-	-	-	729
Stage 1	-	-	-	-	845
Stage 2	-	-	-	-	950

Approach	EB	WB	NB
HCM Control Delay, s	0	0	0
HCM LOS			A

Minor Lane/Major Mvmt	NBLn1	NBLn2	EBT	EBR	WBL	WBT
Capacity (veh/h)	-	-	-	-	1387	-
HCM Lane V/C Ratio	-	-	-	-	-	-
HCM Control Delay (s)	0	0	-	-	0	-
HCM Lane LOS	A	A	-	-	A	-
HCM 95th %tile Q(veh)	-	-	-	-	0	-

# HCM 6th Signalized Intersection Summary

2028 Opening Year No Project Conditions

10: US 101 NB Off Ramp/Lakewood Drive & Old Redwood Highway

Timing Plan: A.M. PEAK



Movement	EBL	EBT	EBR	WBL	WBT	WBR	NBL	NBT	NBR	SBL	SBT	SBR
Lane Configurations												
Traffic Volume (veh/h)	173	170	0	0	501	170	258	252	90	134	0	608
Future Volume (veh/h)	173	170	0	0	501	170	258	252	90	134	0	608
Initial Q (Qb), veh	0	0	0	0	0	0	0	0	0	0	0	0
Ped-Bike Adj(A_pbT)	1.00		1.00	1.00		0.99	1.00		1.00	1.00		1.00
Parking Bus, Adj	1.00	1.00	1.00	1.00	1.00	1.00	1.00	1.00	1.00	1.00	1.00	1.00
Work Zone On Approach		No			No			No			No	
Adj Sat Flow, veh/h/ln	1870	1870	0	0	1870	1870	1870	1870	1870	1870	0	1870
Adj Flow Rate, veh/h	204	200	0	0	604	205	222	371	100	151	0	0
Peak Hour Factor	0.85	0.85	0.85	0.83	0.83	0.83	0.90	0.90	0.90	0.89	0.89	0.89
Percent Heavy Veh, %	2	2	0	0	2	2	2	2	2	2	0	2
Cap, veh/h	371	1187	0	0	1205	408	375	599	159	0	0	
Arrive On Green	0.11	0.63	0.00	0.00	0.46	0.46	0.21	0.21	0.21	0.00	0.00	0.00
Sat Flow, veh/h	3456	1870	0	0	2689	879	1781	2845	757		0	
Grp Volume(v), veh/h	204	200	0	0	413	396	222	242	229		0.0	
Grp Sat Flow(s),veh/h/ln	1728	1870	0	0	1777	1698	1781	1870	1732			
Q Serve(g_s), s	3.5	2.8	0.0	0.0	10.3	10.3	7.1	7.4	7.6			
Cycle Q Clear(g_c), s	3.5	2.8	0.0	0.0	10.3	10.3	7.1	7.4	7.6			
Prop In Lane	1.00		0.00	0.00		0.52	1.00		0.44			
Lane Grp Cap(c), veh/h	371	1187	0	0	825	788	375	394	365			
V/C Ratio(X)	0.55	0.17	0.00	0.00	0.50	0.50	0.59	0.62	0.63			
Avail Cap(c_a), veh/h	491	1187	0	0	825	788	816	856	793			
HCM Platoon Ratio	1.00	1.00	1.00	1.00	1.00	1.00	1.00	1.00	1.00			
Upstream Filter(I)	1.00	1.00	0.00	0.00	1.00	1.00	1.00	1.00	1.00			
Uniform Delay (d), s/veh	26.8	4.7	0.0	0.0	11.8	11.9	22.5	22.7	22.7			
Incr Delay (d2), s/veh	1.3	0.3	0.0	0.0	2.2	2.3	1.5	1.6	1.8			
Initial Q Delay(d3),s/veh	0.0	0.0	0.0	0.0	0.0	0.0	0.0	0.0	0.0			
%ile BackOfQ(50%),veh/ln	1.4	0.8	0.0	0.0	3.9	3.8	2.9	3.2	3.1			
Unsig. Movement Delay, s/veh												
LnGrp Delay(d),s/veh	28.1	5.0	0.0	0.0	14.0	14.1	24.0	24.2	24.5			
LnGrp LOS	C	A	A	A	B	B	C	C	C			
Approach Vol, veh/h	404		809				693					
Approach Delay, s/veh	16.7		14.1				24.3					
Approach LOS	B		B				C					
Timer - Assigned Phs	2		5				6			8		
Phs Duration (G+Y+Rc), s	45.3		10.8				34.5			18.0		
Change Period (Y+Rc), s	5.1		4.0				5.1			4.7		
Max Green Setting (Gmax), s	40.2		9.0				27.2			29.0		
Max Q Clear Time (g_c+I1), s	4.8		5.5				12.3			9.6		
Green Ext Time (p_c), s	1.1		0.2				4.5			3.4		

## Intersection Summary

HCM 6th Ctrl Delay	18.3
HCM 6th LOS	B

## Notes

- User approved volume balancing among the lanes for turning movement.
- Unsignalized Delay for [SBR] is excluded from calculations of the approach delay and intersection delay.

HCM 6th Signalized Intersection Summary 2028 Opening Year No Project Conditions  
 12: US 101 SB On Ramp/US 101 SB Off Ramp & Old Redwood Highway Timing Plan: A.M. PEAK

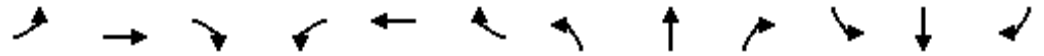























Movement	EBL	EBT	EBR	WBL	WBT	WBR	NBL	NBT	NBR	SBL	SBT	SBR
Lane Configurations		↑↑	↗	↘	↑↑					↘	↕	
Traffic Volume (veh/h)	0	339	337	584	574	0	0	0	0	105	1	74
Future Volume (veh/h)	0	339	337	584	574	0	0	0	0	105	1	74
Initial Q (Qb), veh	0	0	0	0	0	0				0	0	0
Ped-Bike Adj(A_pbT)	1.00		0.98	1.00		1.00				1.00		1.00
Parking Bus, Adj	1.00	1.00	1.00	1.00	1.00	1.00				1.00	1.00	1.00
Work Zone On Approach		No			No						No	
Adj Sat Flow, veh/h/ln	0	1870	1870	1870	1870	0				1870	1870	1870
Adj Flow Rate, veh/h	0	368	366	656	645	0				111	28	0
Peak Hour Factor	0.92	0.92	0.92	0.89	0.89	0.89				0.81	0.81	0.81
Percent Heavy Veh, %	0	2	2	2	2	0				2	2	2
Cap, veh/h	0	1215	533	649	2690	0				214	224	
Arrive On Green	0.00	0.34	0.34	0.36	0.76	0.00				0.12	0.12	0.00
Sat Flow, veh/h	0	3647	1560	1781	3647	0				1781	1870	0
Grp Volume(v), veh/h	0	368	366	656	645	0				111	28	0
Grp Sat Flow(s),veh/h/ln	0	1777	1560	1781	1777	0				1781	1870	0
Q Serve(g_s), s	0.0	6.0	16.0	29.0	4.3	0.0				4.7	1.1	0.0
Cycle Q Clear(g_c), s	0.0	6.0	16.0	29.0	4.3	0.0				4.7	1.1	0.0
Prop In Lane	0.00		1.00	1.00		0.00				1.00		0.00
Lane Grp Cap(c), veh/h	0	1215	533	649	2690	0				214	224	
V/C Ratio(X)	0.00	0.30	0.69	1.01	0.24	0.00				0.52	0.12	
Avail Cap(c_a), veh/h	0	1215	533	649	2690	0				224	235	
HCM Platoon Ratio	1.00	1.00	1.00	1.00	1.00	1.00				1.00	1.00	1.00
Upstream Filter(I)	0.00	1.00	1.00	1.00	1.00	0.00				1.00	1.00	0.00
Uniform Delay (d), s/veh	0.0	19.2	22.5	25.3	2.9	0.0				32.9	31.3	0.0
Incr Delay (d2), s/veh	0.0	0.6	7.0	37.8	0.2	0.0				2.0	0.2	0.0
Initial Q Delay(d3),s/veh	0.0	0.0	0.0	0.0	0.0	0.0				0.0	0.0	0.0
%ile BackOfQ(50%),veh/ln	0.0	2.5	6.5	18.0	1.0	0.0				2.1	0.5	0.0
Unsig. Movement Delay, s/veh												
LnGrp Delay(d),s/veh	0.0	19.9	29.5	63.1	3.1	0.0				34.8	31.5	0.0
LnGrp LOS	A	B	C	F	A	A				C	C	
Approach Vol, veh/h		734			1301							139
Approach Delay, s/veh		24.7			33.3							34.1
Approach LOS		C			C							C
Timer - Assigned Phs		2			5	6		8				
Phs Duration (G+Y+Rc), s		65.3			33.0	32.3		14.2				
Change Period (Y+Rc), s		5.1			4.0	5.1		4.7				
Max Green Setting (Gmax), s		60.2			29.0	27.2		10.0				
Max Q Clear Time (g_c+I1), s		6.3			31.0	18.0		6.7				
Green Ext Time (p_c), s		5.0			0.0	2.6		0.1				
<b>Intersection Summary</b>												
HCM 6th Ctrl Delay			30.5									
HCM 6th LOS			C									
<b>Notes</b>												
User approved volume balancing among the lanes for turning movement.												
User approved ignoring U-Turning movement.												
Unsignalized Delay for [SBR] is excluded from calculations of the approach delay and intersection delay.												



HCM 6th Signalized Intersection Summary  
 1: Old Redwood Hwy & Shiloh Road

























2028 Opening Year No Project Conditions  
 Timing Plan: P.M. Peak

												
Movement	EBL	EBT	EBR	WBL	WBT	WBR	NBL	NBT	NBR	SBL	SBT	SBR
Lane Configurations												
Traffic Volume (veh/h)	290	98	208	42	91	18	186	386	24	26	269	183
Future Volume (veh/h)	290	98	208	42	91	18	186	386	24	26	269	183
Initial Q (Qb), veh	0	0	0	0	0	0	0	0	0	0	0	0
Ped-Bike Adj(A_pbT)	1.00		1.00	1.00		1.00	1.00		0.97	1.00		0.97
Parking Bus, Adj	1.00	1.00	1.00	1.00	1.00	1.00	1.00	1.00	1.00	1.00	1.00	1.00
Work Zone On Approach		No			No			No			No	
Adj Sat Flow, veh/h/ln	1870	1870	1870	1870	1870	1870	1870	1870	1870	1870	1870	1870
Adj Flow Rate, veh/h	299	101	214	46	100	20	200	415	26	28	289	197
Peak Hour Factor	0.97	0.97	0.97	0.91	0.91	0.91	0.93	0.93	0.93	0.93	0.93	0.93
Percent Heavy Veh, %	2	2	2	2	2	2	2	2	2	2	2	2
Cap, veh/h	403	423	358	69	151	189	260	534	441	149	418	345
Arrive On Green	0.23	0.23	0.23	0.12	0.12	0.12	0.15	0.29	0.29	0.08	0.22	0.22
Sat Flow, veh/h	1781	1870	1582	580	1261	1578	1781	1870	1544	1781	1870	1542
Grp Volume(v), veh/h	299	101	214	146	0	20	200	415	26	28	289	197
Grp Sat Flow(s),veh/h/ln	1781	1870	1582	1841	0	1578	1781	1870	1544	1781	1870	1542
Q Serve(g_s), s	9.3	2.6	7.2	4.5	0.0	0.7	6.4	12.2	0.7	0.9	8.5	6.8
Cycle Q Clear(g_c), s	9.3	2.6	7.2	4.5	0.0	0.7	6.4	12.2	0.7	0.9	8.5	6.8
Prop In Lane	1.00		1.00	0.32		1.00	1.00		1.00	1.00		1.00
Lane Grp Cap(c), veh/h	403	423	358	220	0	189	260	534	441	149	418	345
V/C Ratio(X)	0.74	0.24	0.60	0.66	0.00	0.11	0.77	0.78	0.06	0.19	0.69	0.57
Avail Cap(c_a), veh/h	910	956	808	1173	0	1005	433	1363	1126	179	1097	904
HCM Platoon Ratio	1.00	1.00	1.00	1.00	1.00	1.00	1.00	1.00	1.00	1.00	1.00	1.00
Upstream Filter(I)	1.00	1.00	1.00	1.00	0.00	1.00	1.00	1.00	1.00	1.00	1.00	1.00
Uniform Delay (d), s/veh	21.5	18.9	20.7	25.1	0.0	23.4	24.5	19.6	15.5	25.4	21.3	20.6
Incr Delay (d2), s/veh	2.7	0.3	1.6	3.4	0.0	0.2	4.8	2.5	0.1	0.6	2.0	1.5
Initial Q Delay(d3),s/veh	0.0	0.0	0.0	0.0	0.0	0.0	0.0	0.0	0.0	0.0	0.0	0.0
%ile BackOfQ(50%),veh/ln	3.7	1.0	2.5	2.0	0.0	0.2	2.7	4.8	0.2	0.4	3.5	2.3
Unsig. Movement Delay, s/veh												
LnGrp Delay(d),s/veh	24.2	19.2	22.3	28.5	0.0	23.7	29.3	22.0	15.5	26.0	23.3	22.1
LnGrp LOS	C	B	C	C	A	C	C	C	B	C	C	C
Approach Vol, veh/h		614			166			641			514	
Approach Delay, s/veh		22.7			27.9			24.0			23.0	
Approach LOS		C			C			C			C	
Timer - Assigned Phs		2	3	4		6	7	8				
Phs Duration (G+Y+Rc), s		18.0	12.2	17.8		11.6	8.5	21.5				
Change Period (Y+Rc), s		4.5	3.5	4.5		4.5	3.5	4.5				
Max Green Setting (Gmax), s		30.5	14.5	35.0		38.0	6.0	43.5				
Max Q Clear Time (g_c+I1), s		11.3	8.4	10.5		6.5	2.9	14.2				
Green Ext Time (p_c), s		2.0	0.3	2.3		0.8	0.0	2.5				
<b>Intersection Summary</b>												
HCM 6th Ctrl Delay			23.7									
HCM 6th LOS			C									

HCM 6th Signalized Intersection Summary  
 2: Shiloh Road & Hembree Ln

2028 Opening Year No Project Conditions

Timing Plan: P.M. Peak

												
Movement	EBL	EBT	EBR	WBL	WBT	WBR	NBL	NBT	NBR	SBL	SBT	SBR
Lane Configurations	 			 	 						 	
Traffic Volume (veh/h)	700	435	44	24	323	165	65	11	15	194	11	565
Future Volume (veh/h)	700	435	44	24	323	165	65	11	15	194	11	565
Initial Q (Qb), veh	0	0	0	0	0	0	0	0	0	0	0	0
Ped-Bike Adj(A_pbT)	1.00		1.00	1.00		1.00	1.00		1.00	1.00		1.00
Parking Bus, Adj	1.00	1.00	1.00	1.00	1.00	1.00	1.00	1.00	1.00	1.00	1.00	1.00
Work Zone On Approach		No			No			No			No	
Adj Sat Flow, veh/h/ln	1870	1870	1870	1870	1870	1870	1870	1870	1870	1870	1870	1870
Adj Flow Rate, veh/h	745	463	44	24	371	190	65	11	15	204	11	595
Peak Hour Factor	0.94	0.94	1.00	1.00	0.87	0.87	1.00	1.00	1.00	0.95	1.00	0.95
Percent Heavy Veh, %	2	2	2	2	2	2	2	2	2	2	2	2
Cap, veh/h	873	802	76	49	576	290	115	46	63	281	15	663
Arrive On Green	0.25	0.48	0.48	0.03	0.25	0.25	0.06	0.06	0.06	0.17	0.17	0.17
Sat Flow, veh/h	3456	1682	160	1781	2285	1152	1781	717	978	1694	91	1585
Grp Volume(v), veh/h	745	0	507	24	287	274	65	0	26	215	0	595
Grp Sat Flow(s),veh/h/ln	1728	0	1841	1781	1777	1660	1781	0	1694	1786	0	1585
Q Serve(g_s), s	12.4	0.0	12.0	0.8	8.7	8.9	2.1	0.0	0.9	6.9	0.0	10.0
Cycle Q Clear(g_c), s	12.4	0.0	12.0	0.8	8.7	8.9	2.1	0.0	0.9	6.9	0.0	10.0
Prop In Lane	1.00		0.09	1.00		0.69	1.00		0.58	0.95		1.00
Lane Grp Cap(c), veh/h	873	0	879	49	448	418	115	0	110	296	0	663
V/C Ratio(X)	0.85	0.00	0.58	0.49	0.64	0.65	0.56	0.00	0.24	0.73	0.00	0.90
Avail Cap(c_a), veh/h	973	0	1616	162	1221	1141	162	0	154	296	0	663
HCM Platoon Ratio	1.00	1.00	1.00	1.00	1.00	1.00	1.00	1.00	1.00	1.00	1.00	1.00
Upstream Filter(I)	1.00	0.00	1.00	1.00	1.00	1.00	1.00	0.00	1.00	1.00	0.00	1.00
Uniform Delay (d), s/veh	21.5	0.0	11.4	28.9	20.1	20.2	27.4	0.0	26.8	23.9	0.0	16.4
Incr Delay (d2), s/veh	6.9	0.0	0.6	7.4	1.5	1.7	4.2	0.0	1.1	8.7	0.0	15.1
Initial Q Delay(d3),s/veh	0.0	0.0	0.0	0.0	0.0	0.0	0.0	0.0	0.0	0.0	0.0	0.0
%ile BackOfQ(50%),veh/ln	5.2	0.0	3.9	0.4	3.3	3.2	1.0	0.0	0.4	3.4	0.0	9.3
Unsig. Movement Delay, s/veh												
LnGrp Delay(d),s/veh	28.4	0.0	12.0	36.4	21.7	22.0	31.7	0.0	27.9	32.6	0.0	31.5
LnGrp LOS	C	A	B	D	C	C	C	A	C	C	A	C
Approach Vol, veh/h		1252			585			91			810	
Approach Delay, s/veh		21.8			22.4			30.6			31.7	
Approach LOS		C			C			C			C	
Timer - Assigned Phs	1	2		4	5	6		8				
Phs Duration (G+Y+Rc), s	5.7	32.8		14.0	19.2	19.2		7.9				
Change Period (Y+Rc), s	4.0	4.0		4.0	4.0	4.0		4.0				
Max Green Setting (Gmax), s	5.5	53.0		10.0	17.0	41.5		5.5				
Max Q Clear Time (g_c+I1), s	2.8	14.0		12.0	14.4	10.9		4.1				
Green Ext Time (p_c), s	0.0	3.4		0.0	0.8	3.5		0.0				
<b>Intersection Summary</b>												
HCM 6th Ctrl Delay				25.1								
HCM 6th LOS				C								

HCM 6th Signalized Intersection Summary  
 3: US 101 NB Off-Ramp & Shiloh Road

2028 Opening Year No Project Conditions  
 Timing Plan: P.M. Peak



Movement	EBT	EBR	WBL	WBT	NBL	NBR
Lane Configurations	↑↑			↑	↘	↗
Traffic Volume (veh/h)	435	0	0	668	599	749
Future Volume (veh/h)	435	0	0	668	599	749
Initial Q (Qb), veh	0	0	0	0	0	0
Ped-Bike Adj(A_pbT)		1.00	1.00		1.00	1.00
Parking Bus, Adj	1.00	1.00	1.00	1.00	1.00	1.00
Work Zone On Approach	No			No	No	
Adj Sat Flow, veh/h/ln	1870	0	0	1870	1870	1870
Adj Flow Rate, veh/h	463	0	0	689	666	832
Peak Hour Factor	0.94	0.94	0.97	0.97	0.90	0.90
Percent Heavy Veh, %	2	0	0	2	2	2
Cap, veh/h	1510	0	0	795	785	1230
Arrive On Green	0.42	0.00	0.00	0.42	0.44	0.44
Sat Flow, veh/h	3741	0	0	1870	1781	2790
Grp Volume(v), veh/h	463	0	0	689	666	832
Grp Sat Flow(s),veh/h/ln	1777	0	0	1870	1781	1395
Q Serve(g_s), s	5.1	0.0	0.0	20.0	19.9	14.2
Cycle Q Clear(g_c), s	5.1	0.0	0.0	20.0	19.9	14.2
Prop In Lane		0.00	0.00		1.00	1.00
Lane Grp Cap(c), veh/h	1510	0	0	795	785	1230
V/C Ratio(X)	0.31	0.00	0.00	0.87	0.85	0.68
Avail Cap(c_a), veh/h	1969	0	0	1036	927	1452
HCM Platoon Ratio	1.00	1.00	1.00	1.00	1.00	1.00
Upstream Filter(I)	1.00	0.00	0.00	1.00	1.00	1.00
Uniform Delay (d), s/veh	11.3	0.0	0.0	15.6	14.9	13.3
Incr Delay (d2), s/veh	0.1	0.0	0.0	6.3	6.5	1.0
Initial Q Delay(d3),s/veh	0.0	0.0	0.0	0.0	0.0	0.0
%ile BackOfQ(50%),veh/ln	1.7	0.0	0.0	8.1	8.2	4.0
Unsig. Movement Delay, s/veh						
LnGrp Delay(d),s/veh	11.4	0.0	0.0	21.9	21.4	14.3
LnGrp LOS	B	A	A	C	C	B
Approach Vol, veh/h	463			689	1498	
Approach Delay, s/veh	11.4			21.9	17.5	
Approach LOS	B			C	B	
Timer - Assigned Phs		2			6	8
Phs Duration (G+Y+Rc), s		29.3			29.3	30.3
Change Period (Y+Rc), s		4.0			4.0	4.0
Max Green Setting (Gmax), s		33.0			33.0	31.0
Max Q Clear Time (g_c+I1), s		7.1			22.0	21.9
Green Ext Time (p_c), s		2.9			3.3	4.4
<b>Intersection Summary</b>						
HCM 6th Ctrl Delay			17.6			
HCM 6th LOS			B			

HCM Signalized Intersection Capacity Analysis  
 4: Shiloh Road & US 101 SB Off-Ramp

2028 Opening Year No Project Conditions

Timing Plan: P.M. Peak



Movement	EBL	EBT	WBT	WBR	SBL	SBR
Lane Configurations		↑	↑		↘	↘
Traffic Volume (vph)	0	498	714	0	140	146
Future Volume (vph)	0	498	714	0	140	146
Ideal Flow (vphpl)	1900	1900	1900	1900	1900	1900
Total Lost time (s)		4.0	4.0		4.0	4.0
Lane Util. Factor		1.00	1.00		1.00	1.00
Frbp, ped/bikes		1.00	1.00		1.00	0.98
Flpb, ped/bikes		1.00	1.00		1.00	1.00
Frt		1.00	1.00		1.00	0.85
Flt Protected		1.00	1.00		0.95	1.00
Satd. Flow (prot)		1863	1863		1770	1548
Flt Permitted		1.00	1.00		0.95	1.00
Satd. Flow (perm)		1863	1863		1770	1548
Peak-hour factor, PHF	0.89	0.89	0.96	0.96	0.93	0.93
Adj. Flow (vph)	0	560	744	0	151	157
RTOR Reduction (vph)	0	0	0	0	0	121
Lane Group Flow (vph)	0	560	744	0	151	36
Confl. Peds. (#/hr)						1
Turn Type		NA	NA		Perm	Perm
Protected Phases		2	6			
Permitted Phases					4	4
Actuated Green, G (s)		23.2	23.2		9.3	9.3
Effective Green, g (s)		23.2	23.2		9.3	9.3
Actuated g/C Ratio		0.57	0.57		0.23	0.23
Clearance Time (s)		4.0	4.0		4.0	4.0
Vehicle Extension (s)		3.0	3.0		3.0	3.0
Lane Grp Cap (vph)		1067	1067		406	355
v/s Ratio Prot		0.30	c0.40			
v/s Ratio Perm					c0.09	0.02
v/c Ratio		0.52	0.70		0.37	0.10
Uniform Delay, d1		5.3	6.2		13.1	12.3
Progression Factor		1.00	1.00		1.00	1.00
Incremental Delay, d2		0.5	2.0		0.6	0.1
Delay (s)		5.8	8.2		13.7	12.4
Level of Service		A	A		B	B
Approach Delay (s)		5.8	8.2		13.1	
Approach LOS		A	A		B	
<b>Intersection Summary</b>						
HCM 2000 Control Delay			8.3		HCM 2000 Level of Service	A
HCM 2000 Volume to Capacity ratio			0.60			
Actuated Cycle Length (s)			40.5		Sum of lost time (s)	8.0
Intersection Capacity Utilization			67.3%		ICU Level of Service	C
Analysis Period (min)			15			
c Critical Lane Group						

Intersection						
Int Delay, s/veh	3.3					
Movement	EBT	EBR	WBL	WBT	NBL	NBR
Lane Configurations	↑↑		↖	↑	↖	↖
Traffic Vol, veh/h	969	32	90	741	17	170
Future Vol, veh/h	969	32	90	741	17	170
Conflicting Peds, #/hr	0	0	0	0	0	0
Sign Control	Free	Free	Free	Free	Stop	Stop
RT Channelized	-	None	-	None	-	None
Storage Length	-	-	68	-	0	0
Veh in Median Storage, #	0	-	-	0	0	-
Grade, %	0	-	-	0	0	-
Peak Hour Factor	89	89	92	92	89	89
Heavy Vehicles, %	2	2	2	2	2	2
Mvmt Flow	1089	36	98	805	19	191



















Major/Minor	Major1	Major2	Minor1		
Conflicting Flow All	0	0	1125	0	2108
Stage 1	-	-	-	-	1107
Stage 2	-	-	-	-	1001
Critical Hdwy	-	-	4.13	-	6.63
Critical Hdwy Stg 1	-	-	-	-	5.83
Critical Hdwy Stg 2	-	-	-	-	5.43
Follow-up Hdwy	-	-	2.219	-	3.519
Pot Cap-1 Maneuver	-	-	619	-	50
Stage 1	-	-	-	-	279
Stage 2	-	-	-	-	354
Platoon blocked, %	-	-	-	-	-
Mov Cap-1 Maneuver	-	-	619	-	42
Mov Cap-2 Maneuver	-	-	-	-	42
Stage 1	-	-	-	-	279
Stage 2	-	-	-	-	298

Approach	EB	WB	NB
HCM Control Delay, s	0	1.3	29.7
HCM LOS			D

Minor Lane/Major Mvmt	NBLn1	NBLn2	EBT	EBR	WBL	WBT
Capacity (veh/h)	42	470	-	-	619	-
HCM Lane V/C Ratio	0.455	0.406	-	-	0.158	-
HCM Control Delay (s)	148.6	17.8	-	-	11.9	-
HCM Lane LOS	F	C	-	-	B	-
HCM 95th %tile Q(veh)	1.6	1.9	-	-	0.6	-

HCM Signalized Intersection Capacity Analysis  
6: Conde Lane & Shiloh Road

2028 Opening Year No Project Conditions  
Timing Plan: P.M. Peak

												
Movement	EBL	EBT	EBR	WBL	WBT	WBR	NBL	NBT	NBR	SBL	SBT	SBR
Lane Configurations												
Traffic Volume (vph)	79	535	2	8	519	329	6	3	19	338	0	44
Future Volume (vph)	79	535	2	8	519	329	6	3	19	338	0	44
Ideal Flow (vphp)	1900	1900	1900	1900	1900	1900	1900	1900	1900	1900	1900	1900
Total Lost time (s)	4.0	4.0		4.0	4.0			4.0			4.0	4.0
Lane Util. Factor	1.00	0.95		1.00	0.95			1.00			1.00	1.00
Frbp, ped/bikes	1.00	1.00		1.00	0.99			1.00			1.00	1.00
Flpb, ped/bikes	1.00	1.00		1.00	1.00			1.00			1.00	1.00
Frt	1.00	1.00		1.00	0.94			0.91			1.00	0.85
Flt Protected	0.95	1.00		0.95	1.00			0.99			0.95	1.00
Satd. Flow (prot)	1770	3537		1770	3306			1676			1770	1583
Flt Permitted	0.95	1.00		0.95	1.00			0.99			0.95	1.00
Satd. Flow (perm)	1770	3537		1770	3306			1676			1770	1583
Peak-hour factor, PHF	0.88	0.88	0.88	0.80	0.80	0.80	0.63	0.63	0.63	0.88	0.88	0.88
Adj. Flow (vph)	90	608	2	10	649	411	10	5	30	384	0	50
RTOR Reduction (vph)	0	0	0	0	84	0	0	28	0	0	0	0
Lane Group Flow (vph)	90	610	0	10	976	0	0	17	0	0	384	50
Confl. Peds. (#/hr)	1					1						
Turn Type	Prot	NA		Prot	NA		Split	NA		Split	NA	custom
Protected Phases	5	2		1	6		7	7		4	4	
Permitted Phases												6
Actuated Green, G (s)	6.4	34.6		1.2	29.4			4.9			12.6	29.4
Effective Green, g (s)	6.4	34.6		1.2	29.4			4.9			12.6	29.4
Actuated g/C Ratio	0.09	0.50		0.02	0.42			0.07			0.18	0.42
Clearance Time (s)	4.0	4.0		4.0	4.0			4.0			4.0	4.0
Vehicle Extension (s)	3.0	3.0		3.0	3.0			3.0			3.0	3.0
Lane Grp Cap (vph)	163	1765		30	1402			118			321	671
v/s Ratio Prot	c0.05	0.17		0.01	c0.30			c0.01			c0.22	
v/s Ratio Perm												0.03
v/c Ratio	0.55	0.35		0.33	0.70			0.15			1.20	0.07
Uniform Delay, d1	30.1	10.5		33.7	16.3			30.2			28.3	11.9
Progression Factor	1.00	1.00		1.00	1.00			1.00			1.00	1.00
Incremental Delay, d2	4.0	0.1		6.5	1.5			0.6			114.6	0.0
Delay (s)	34.1	10.6		40.1	17.8			30.8			143.0	11.9
Level of Service	C	B		D	B			C			F	B
Approach Delay (s)		13.6			18.0			30.8			127.9	
Approach LOS		B			B			C			F	
<b>Intersection Summary</b>												
HCM 2000 Control Delay			38.1									HCM 2000 Level of Service D
HCM 2000 Volume to Capacity ratio			0.75									
Actuated Cycle Length (s)			69.3									Sum of lost time (s) 16.0
Intersection Capacity Utilization			67.0%									ICU Level of Service C
Analysis Period (min)			15									
c Critical Lane Group												

HCM 6th TWSC  
7: Entrance 1/Gridley Drive & Shiloh Road

2028 Opening Year No Project Conditions  
Timing Plan: P.M. Peak

Intersection												
Int Delay, s/veh	1.1											
Movement	EBL	EBT	EBR	WBL	WBT	WBR	NBL	NBT	NBR	SBL	SBT	SBR
Lane Configurations		↕			↕		↕	↕			↕	
Traffic Vol, veh/h	19	117	0	0	142	0	0	0	0	0	0	16
Future Vol, veh/h	19	117	0	0	142	0	0	0	0	0	0	16
Conflicting Peds, #/hr	1	0	0	0	0	0	0	0	0	0	0	0
Sign Control	Free	Free	Free	Free	Free	Free	Stop	Stop	Stop	Stop	Stop	Stop
RT Channelized	-	-	None	-	-	None	-	-	None	-	-	None
Storage Length	-	-	-	-	-	-	0	-	-	-	-	-
Veh in Median Storage, #	-	0	-	-	0	-	-	0	-	-	0	-
Grade, %	-	0	-	-	0	-	-	0	-	-	0	-
Peak Hour Factor	94	94	94	69	69	69	100	100	100	58	58	58
Heavy Vehicles, %	2	2	2	2	2	2	2	2	2	2	2	2
Mvmt Flow	20	124	0	0	206	0	0	0	0	0	0	28

Major/Minor	Major1			Major2			Minor1			Minor2		
Conflicting Flow All	207	0	0	124	0	0	384	371	124	371	371	207
Stage 1	-	-	-	-	-	-	164	164	-	207	207	-
Stage 2	-	-	-	-	-	-	220	207	-	164	164	-
Critical Hdwy	4.12	-	-	4.12	-	-	7.12	6.52	6.22	7.12	6.52	6.22
Critical Hdwy Stg 1	-	-	-	-	-	-	6.12	5.52	-	6.12	5.52	-
Critical Hdwy Stg 2	-	-	-	-	-	-	6.12	5.52	-	6.12	5.52	-
Follow-up Hdwy	2.218	-	-	2.218	-	-	3.518	4.018	3.318	3.518	4.018	3.318
Pot Cap-1 Maneuver	1364	-	-	1463	-	-	574	559	927	586	559	833
Stage 1	-	-	-	-	-	-	838	762	-	795	731	-
Stage 2	-	-	-	-	-	-	782	731	-	838	762	-
Platoon blocked, %		-	-		-	-						
Mov Cap-1 Maneuver	1363	-	-	1463	-	-	548	549	927	578	549	832
Mov Cap-2 Maneuver	-	-	-	-	-	-	548	549	-	578	549	-
Stage 1	-	-	-	-	-	-	825	750	-	781	730	-
Stage 2	-	-	-	-	-	-	756	730	-	825	750	-

Approach	EB	WB	NB	SB
HCM Control Delay, s	1.1	0	0	9.5
HCM LOS			A	A

Minor Lane/Major Mvmt	NBLn1	NBLn2	EBL	EBT	EBR	WBL	WBT	WBR	SBLn1
Capacity (veh/h)	-	-	1363	-	-	1463	-	-	832
HCM Lane V/C Ratio	-	-	0.015	-	-	-	-	-	0.033
HCM Control Delay (s)	0	0	7.7	0	-	0	-	-	9.5
HCM Lane LOS	A	A	A	A	-	A	-	-	A
HCM 95th %tile Q(veh)	-	-	0	-	-	0	-	-	0.1

HCM 6th TWSC  
8: Old Redwood Hwy & Entrance 1

2028 Opening Year No Project Conditions  
Timing Plan: P.M. Peak

Intersection												
Int Delay, s/veh	0.2											
Movement	EBL	EBT	EBR	WBL	WBT	WBR	NBL	NBT	NBR	SBL	SBT	SBR
Lane Configurations		↕		↕	↕			↕		↕	↕	
Traffic Vol, veh/h	3	0	0	0	0	0	0	575	0	0	486	0
Future Vol, veh/h	3	0	0	0	0	0	0	575	0	0	486	0
Conflicting Peds, #/hr	0	0	0	0	0	0	0	0	0	0	0	0
Sign Control	Stop	Stop	Stop	Stop	Stop	Stop	Free	Free	Free	Free	Free	Free
RT Channelized	-	-	None	-	-	None	-	-	None	-	-	None
Storage Length	-	-	-	0	-	-	-	-	-	50	-	-
Veh in Median Storage, #	-	0	-	-	0	-	-	0	-	-	0	-
Grade, %	-	0	-	-	0	-	-	0	-	-	0	-
Peak Hour Factor	38	38	38	100	100	100	91	91	91	94	94	94
Heavy Vehicles, %	2	2	2	2	2	2	2	2	2	2	2	2
Mvmt Flow	8	0	0	0	0	0	0	632	0	0	517	0

Major/Minor	Minor2		Minor1		Major1		Major2					
Conflicting Flow All	1149	1149	517	1149	1149	632	517	0	0	632	0	0
Stage 1	517	517	-	632	632	-	-	-	-	-	-	-
Stage 2	632	632	-	517	517	-	-	-	-	-	-	-
Critical Hdwy	7.12	6.52	6.22	7.12	6.52	6.22	4.12	-	-	4.12	-	-
Critical Hdwy Stg 1	6.12	5.52	-	6.12	5.52	-	-	-	-	-	-	-
Critical Hdwy Stg 2	6.12	5.52	-	6.12	5.52	-	-	-	-	-	-	-
Follow-up Hdwy	3.518	4.018	3.318	3.518	4.018	3.318	2.218	-	-	2.218	-	-
Pot Cap-1 Maneuver	176	198	558	176	198	480	1049	-	-	951	-	-
Stage 1	541	534	-	468	474	-	-	-	-	-	-	-
Stage 2	468	474	-	541	534	-	-	-	-	-	-	-
Platoon blocked, %								-	-	-	-	-
Mov Cap-1 Maneuver	176	198	558	176	198	480	1049	-	-	951	-	-
Mov Cap-2 Maneuver	176	198	-	176	198	-	-	-	-	-	-	-
Stage 1	541	534	-	468	474	-	-	-	-	-	-	-
Stage 2	468	474	-	541	534	-	-	-	-	-	-	-

Approach	EB	WB	NB	SB
HCM Control Delay, s	26.4	0	0	0
HCM LOS	D	A		

Minor Lane/Major Mvmt	NBL	NBT	NBR	EBLn1	WBLn1	WBLn2	SBL	SBT	SBR
Capacity (veh/h)	1049	-	-	176	-	-	951	-	-
HCM Lane V/C Ratio	-	-	-	0.045	-	-	-	-	-
HCM Control Delay (s)	0	-	-	26.4	0	0	0	-	-
HCM Lane LOS	A	-	-	D	A	A	A	-	-
HCM 95th %tile Q(veh)	0	-	-	0.1	-	-	0	-	-



Intersection						
Int Delay, s/veh	0					
Movement	EBT	EBR	WBL	WBT	NBL	NBR
Lane Configurations	↶			↷	↷	↷
Traffic Vol, veh/h	92	0	0	126	0	0
Future Vol, veh/h	92	0	0	126	0	0
Conflicting Peds, #/hr	0	0	0	0	0	0
Sign Control	Free	Free	Free	Free	Stop	Stop
RT Channelized	-	None	-	None	-	None
Storage Length	-	-	-	-	0	0
Veh in Median Storage, #	0	-	-	0	0	-
Grade, %	0	-	-	0	0	-
Peak Hour Factor	92	92	68	68	100	100
Heavy Vehicles, %	2	2	2	2	2	2
Mvmt Flow	100	0	0	185	0	0

Major/Minor	Major1	Major2	Minor1		
Conflicting Flow All	0	0	100	0	285
Stage 1	-	-	-	-	100
Stage 2	-	-	-	-	185
Critical Hdwy	-	-	4.12	-	6.42
Critical Hdwy Stg 1	-	-	-	-	5.42
Critical Hdwy Stg 2	-	-	-	-	5.42
Follow-up Hdwy	-	-	2.218	-	3.518
Pot Cap-1 Maneuver	-	-	1493	-	705
Stage 1	-	-	-	-	924
Stage 2	-	-	-	-	847
Platoon blocked, %	-	-	-	-	-
Mov Cap-1 Maneuver	-	-	1493	-	705
Mov Cap-2 Maneuver	-	-	-	-	705
Stage 1	-	-	-	-	924
Stage 2	-	-	-	-	847

Approach	EB	WB	NB
HCM Control Delay, s	0	0	0
HCM LOS			A

Minor Lane/Major Mvmt	NBLn1	NBLn2	EBT	EBR	WBL	WBT
Capacity (veh/h)	-	-	-	-	1493	-
HCM Lane V/C Ratio	-	-	-	-	-	-
HCM Control Delay (s)	0	0	-	-	0	-
HCM Lane LOS	A	A	-	-	A	-
HCM 95th %tile Q(veh)	-	-	-	-	0	-

HCM 6th Signalized Intersection Summary

2028 Opening Year No Project Conditions

10: US 101 NB Off Ramp/Lakewood Drive & Old Redwood Highway

Timing Plan: P.M. Peak

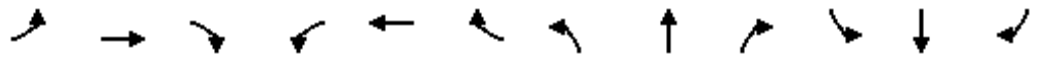

Movement	EBL	EBT	EBR	WBL	WBT	WBR	NBL	NBT	NBR	SBL	SBT	SBR
Lane Configurations	↔↔	↑			↑↑		↔	↔↔		↔↔		↔
Traffic Volume (veh/h)	297	399	0	0	566	219	569	469	286	284	0	657
Future Volume (veh/h)	297	399	0	0	566	219	569	469	286	284	0	657
Initial Q (Qb), veh	0	0	0	0	0	0	0	0	0	0	0	0
Ped-Bike Adj(A_pbT)	1.00		1.00	1.00		0.98	1.00		0.99	1.00		1.00
Parking Bus, Adj	1.00	1.00	1.00	1.00	1.00	1.00	1.00	1.00	1.00	1.00	1.00	1.00
Work Zone On Approach		No			No			No			No	
Adj Sat Flow, veh/h/ln	1870	1870	0	0	1870	1870	1870	1870	1870	1870	0	1870
Adj Flow Rate, veh/h	341	459	0	0	622	241	480	704	311	296	0	0
Peak Hour Factor	0.87	0.87	0.87	0.91	0.91	0.91	0.92	0.92	0.92	0.96	0.96	0.96
Percent Heavy Veh, %	2	2	0	0	2	2	2	2	2	2	0	2
Cap, veh/h	405	980	0	0	882	341	620	854	377	0	0	0
Arrive On Green	0.12	0.52	0.00	0.00	0.35	0.35	0.35	0.35	0.35	0.00	0.00	0.00
Sat Flow, veh/h	3456	1870	0	0	2581	963	1781	2453	1084		0	
Grp Volume(v), veh/h	341	459	0	0	444	419	480	537	478		0.0	
Grp Sat Flow(s),veh/h/ln	1728	1870	0	0	1777	1674	1781	1870	1666			
Q Serve(g_s), s	7.4	11.9	0.0	0.0	16.5	16.5	18.4	20.1	20.1			
Cycle Q Clear(g_c), s	7.4	11.9	0.0	0.0	16.5	16.5	18.4	20.1	20.1			
Prop In Lane	1.00		0.00	0.00		0.58	1.00		0.65			
Lane Grp Cap(c), veh/h	405	980	0	0	630	594	620	651	580			
V/C Ratio(X)	0.84	0.47	0.00	0.00	0.70	0.71	0.77	0.82	0.82			
Avail Cap(c_a), veh/h	405	980	0	0	630	594	673	707	630			
HCM Platoon Ratio	1.00	1.00	1.00	1.00	1.00	1.00	1.00	1.00	1.00			
Upstream Filter(I)	1.00	1.00	0.00	0.00	1.00	1.00	1.00	1.00	1.00			
Uniform Delay (d), s/veh	33.2	11.5	0.0	0.0	21.3	21.3	22.3	22.9	22.9			
Incr Delay (d2), s/veh	14.6	1.6	0.0	0.0	6.5	6.9	5.2	7.4	8.2			
Initial Q Delay(d3),s/veh	0.0	0.0	0.0	0.0	0.0	0.0	0.0	0.0	0.0			
%ile BackOfQ(50%),veh/ln	3.8	4.7	0.0	0.0	7.4	7.1	8.1	9.6	8.7			
Unsig. Movement Delay, s/veh												
LnGrp Delay(d),s/veh	47.8	13.1	0.0	0.0	27.8	28.2	27.5	30.2	31.1			
LnGrp LOS	D	B	A	A	C	C	C	C	C			
Approach Vol, veh/h		800			863			1495				
Approach Delay, s/veh		27.9			28.0			29.6				
Approach LOS		C			C			C				
Timer - Assigned Phs		2			5	6		8				
Phs Duration (G+Y+Rc), s		45.3			13.0	32.3		31.4				
Change Period (Y+Rc), s		5.1			4.0	5.1		4.7				
Max Green Setting (Gmax), s		40.2			9.0	27.2		29.0				
Max Q Clear Time (g_c+I1), s		13.9			9.4	18.5		22.1				
Green Ext Time (p_c), s		2.9			0.0	3.5		4.4				

Intersection Summary

HCM 6th Ctrl Delay	28.7
HCM 6th LOS	C

Notes

User approved volume balancing among the lanes for turning movement.  
 Unsignalized Delay for [SBR] is excluded from calculations of the approach delay and intersection delay.

HCM 6th Signalized Intersection Summary 2028 Opening Year No Project Conditions  
 12: US 101 SB On Ramp/US 101 SB Off Ramp & Old Redwood Highway Timing Plan: P.M. Peak



Movement	EBL	EBT	EBR	WBL	WBT	WBR	NBL	NBT	NBR	SBL	SBT	SBR	
Lane Configurations		↑↑	↗	↘	↑↑					↘	↕		
Traffic Volume (veh/h)	0	609	434	434	1166	0	0	0	0	190	0	147	
Future Volume (veh/h)	0	609	434	434	1166	0	0	0	0	190	0	147	
Initial Q (Qb), veh	0	0	0	0	0	0				0	0	0	
Ped-Bike Adj(A_pbT)	1.00		0.98	1.00		1.00				1.00		1.00	
Parking Bus, Adj	1.00	1.00	1.00	1.00	1.00	1.00				1.00	1.00	1.00	
Work Zone On Approach		No			No						No		
Adj Sat Flow, veh/h/ln	0	1870	1870	1870	1870	0				1870	1870	1870	
Adj Flow Rate, veh/h	0	648	462	488	1310	0				203	36	0	
Peak Hour Factor	0.94	0.94	0.94	0.89	0.89	0.89				0.83	0.83	0.83	
Percent Heavy Veh, %	0	2	2	2	2	0				2	2	2	
Cap, veh/h	0	1425	625	461	2548	0				253	266		
Arrive On Green	0.00	0.40	0.40	0.26	0.72	0.00				0.14	0.14	0.00	
Sat Flow, veh/h	0	3647	1560	1781	3647	0				1781	1870	0	
Grp Volume(v), veh/h	0	648	462	488	1310	0				203	36	0	
Grp Sat Flow(s),veh/h/ln	0	1777	1560	1781	1777	0				1781	1870	0	
Q Serve(g_s), s	0.0	9.3	17.5	18.0	11.5	0.0				7.7	1.2	0.0	
Cycle Q Clear(g_c), s	0.0	9.3	17.5	18.0	11.5	0.0				7.7	1.2	0.0	
Prop In Lane	0.00		1.00	1.00		0.00				1.00		0.00	
Lane Grp Cap(c), veh/h	0	1425	625	461	2548	0				253	266		
V/C Ratio(X)	0.00	0.45	0.74	1.06	0.51	0.00				0.80	0.14		
Avail Cap(c_a), veh/h	0	1425	625	461	2548	0				264	277		
HCM Platoon Ratio	1.00	1.00	1.00	1.00	1.00	1.00				1.00	1.00	1.00	
Upstream Filter(I)	0.00	1.00	1.00	1.00	1.00	0.00				1.00	1.00	0.00	
Uniform Delay (d), s/veh	0.0	15.3	17.7	25.8	4.4	0.0				28.9	26.1	0.0	
Incr Delay (d2), s/veh	0.0	1.0	7.6	58.5	0.7	0.0				15.6	0.2	0.0	
Initial Q Delay(d3),s/veh	0.0	0.0	0.0	0.0	0.0	0.0				0.0	0.0	0.0	
%ile BackOfQ(50%),veh/ln	0.0	3.6	6.9	14.5	2.7	0.0				4.2	0.5	0.0	
Unsig. Movement Delay, s/veh													
LnGrp Delay(d),s/veh	0.0	16.3	25.4	84.3	5.2	0.0				44.5	26.3	0.0	
LnGrp LOS	A	B	C	F	A	A				D	C		
Approach Vol, veh/h		1110			1798					239			
Approach Delay, s/veh		20.1			26.6					41.7			
Approach LOS		C			C					D			
Timer - Assigned Phs		2			5			6			8		
Phs Duration (G+Y+Rc), s		55.0			22.0			33.0			14.6		
Change Period (Y+Rc), s		5.1			4.0			5.1			4.7		
Max Green Setting (Gmax), s		49.9			18.0			27.9			10.3		
Max Q Clear Time (g_c+I1), s		13.5			20.0			19.5			9.7		
Green Ext Time (p_c), s		12.5			0.0			3.8			0.1		

**Intersection Summary**

HCM 6th Ctrl Delay	25.5
HCM 6th LOS	C























**Notes**

- User approved volume balancing among the lanes for turning movement.
- User approved ignoring U-Turning movement.
- Unsignalized Delay for [SBR] is excluded from calculations of the approach delay and intersection delay.

HCM 6th Signalized Intersection Summary  
 1: Old Redwood Hwy & Shiloh Road

2028 Opening Year No Project Conditions

























Timing Plan: Saturday Midday Peak

												
Movement	EBL	EBT	EBR	WBL	WBT	WBR	NBL	NBT	NBR	SBL	SBT	SBR
Lane Configurations												
Traffic Volume (veh/h)	156	83	197	24	83	17	200	266	27	23	216	239
Future Volume (veh/h)	156	83	197	24	83	17	200	266	27	23	216	239
Initial Q (Qb), veh	0	0	0	0	0	0	0	0	0	0	0	0
Ped-Bike Adj(A_pbT)	1.00		0.97	1.00		1.00	1.00		0.98	1.00		0.97
Parking Bus, Adj	1.00	1.00	1.00	1.00	1.00	1.00	1.00	1.00	1.00	1.00	1.00	1.00
Work Zone On Approach		No			No			No			No	
Adj Sat Flow, veh/h/ln	1870	1870	1870	1870	1870	1870	1870	1870	1870	1870	1870	1870
Adj Flow Rate, veh/h	175	93	221	28	97	20	215	286	29	25	237	263
Peak Hour Factor	0.89	0.89	0.89	0.86	0.86	0.86	0.93	0.93	0.93	0.91	0.91	0.91
Percent Heavy Veh, %	2	2	2	2	2	2	2	2	2	2	2	2
Cap, veh/h	370	388	319	42	145	160	277	560	465	155	433	356
Arrive On Green	0.21	0.21	0.21	0.10	0.10	0.10	0.16	0.30	0.30	0.09	0.23	0.23
Sat Flow, veh/h	1781	1870	1536	414	1435	1585	1781	1870	1551	1781	1870	1541
Grp Volume(v), veh/h	175	93	221	125	0	20	215	286	29	25	237	263
Grp Sat Flow(s),veh/h/ln	1781	1870	1536	1850	0	1585	1781	1870	1551	1781	1870	1541
Q Serve(g_s), s	5.0	2.4	7.6	3.7	0.0	0.7	6.7	7.3	0.8	0.7	6.4	9.1
Cycle Q Clear(g_c), s	5.0	2.4	7.6	3.7	0.0	0.7	6.7	7.3	0.8	0.7	6.4	9.1
Prop In Lane	1.00		1.00	0.22		1.00	1.00		1.00	1.00		1.00
Lane Grp Cap(c), veh/h	370	388	319	187	0	160	277	560	465	155	433	356
V/C Ratio(X)	0.47	0.24	0.69	0.67	0.00	0.12	0.78	0.51	0.06	0.16	0.55	0.74
Avail Cap(c_a), veh/h	946	994	816	1224	0	1049	434	1417	1176	171	1140	939
HCM Platoon Ratio	1.00	1.00	1.00	1.00	1.00	1.00	1.00	1.00	1.00	1.00	1.00	1.00
Upstream Filter(I)	1.00	1.00	1.00	1.00	0.00	1.00	1.00	1.00	1.00	1.00	1.00	1.00
Uniform Delay (d), s/veh	20.0	19.0	21.1	24.9	0.0	23.5	23.3	16.6	14.4	24.3	19.4	20.5
Incr Delay (d2), s/veh	0.9	0.3	2.7	4.1	0.0	0.3	4.7	0.7	0.1	0.5	1.1	3.0
Initial Q Delay(d3),s/veh	0.0	0.0	0.0	0.0	0.0	0.0	0.0	0.0	0.0	0.0	0.0	0.0
%ile BackOfQ(50%),veh/ln	1.9	0.9	2.6	1.7	0.0	0.2	2.8	2.7	0.2	0.3	2.5	3.1
Unsig. Movement Delay, s/veh												
LnGrp Delay(d),s/veh	20.9	19.3	23.8	29.0	0.0	23.8	28.0	17.4	14.4	24.7	20.5	23.5
LnGrp LOS	C	B	C	C	A	C	C	B	B	C	C	C
Approach Vol, veh/h		489			145			530			525	
Approach Delay, s/veh		21.9			28.3			21.5			22.2	
Approach LOS		C			C			C			C	
Timer - Assigned Phs		2	3	4		6	7	8				
Phs Duration (G+Y+Rc), s		16.4	12.9	17.8		10.3	9.0	21.7				
Change Period (Y+Rc), s		4.5	4.0	4.5		4.5	4.0	4.5				
Max Green Setting (Gmax), s		30.5	14.0	35.0		38.0	5.5	43.5				
Max Q Clear Time (g_c+I1), s		9.6	8.7	11.1		5.7	2.7	9.3				
Green Ext Time (p_c), s		1.7	0.3	2.2		0.7	0.0	1.7				
<b>Intersection Summary</b>												
HCM 6th Ctrl Delay			22.4									
HCM 6th LOS			C									

HCM 6th Signalized Intersection Summary  
2: Shiloh Road & Hembree Ln

2028 Opening Year No Project Conditions

Timing Plan: Saturday Midday Peak

												
Movement	EBL	EBT	EBR	WBL	WBT	WBR	NBL	NBT	NBR	SBL	SBT	SBR
Lane Configurations	 			 	 						 	
Traffic Volume (veh/h)	708	359	44	24	279	185	65	11	15	182	11	666
Future Volume (veh/h)	708	359	44	24	279	185	65	11	15	182	11	666
Initial Q (Qb), veh	0	0	0	0	0	0	0	0	0	0	0	0
Ped-Bike Adj(A_pbT)	1.00		1.00	1.00		1.00	1.00		1.00	1.00		1.00
Parking Bus, Adj	1.00	1.00	1.00	1.00	1.00	1.00	1.00	1.00	1.00	1.00	1.00	1.00
Work Zone On Approach		No			No			No			No	
Adj Sat Flow, veh/h/ln	1870	1870	1870	1870	1870	1870	1870	1870	1870	1870	1870	1870
Adj Flow Rate, veh/h	753	382	44	24	291	193	65	11	15	200	11	732
Peak Hour Factor	0.94	0.94	1.00	1.00	0.96	0.96	1.00	1.00	1.00	0.91	1.00	0.91
Percent Heavy Veh, %	2	2	2	2	2	2	2	2	2	2	2	2
Cap, veh/h	893	749	86	49	465	300	118	48	65	293	16	684
Arrive On Green	0.26	0.46	0.46	0.03	0.22	0.22	0.07	0.07	0.07	0.17	0.17	0.17
Sat Flow, veh/h	3456	1646	190	1781	2070	1335	1781	717	978	1693	93	1585
Grp Volume(v), veh/h	753	0	426	24	249	235	65	0	26	211	0	732
Grp Sat Flow(s),veh/h/ln	1728	0	1836	1781	1777	1628	1781	0	1694	1786	0	1585
Q Serve(g_s), s	11.9	0.0	9.5	0.8	7.3	7.6	2.0	0.0	0.8	6.4	0.0	10.0
Cycle Q Clear(g_c), s	11.9	0.0	9.5	0.8	7.3	7.6	2.0	0.0	0.8	6.4	0.0	10.0
Prop In Lane	1.00		0.10	1.00		0.82	1.00		0.58	0.95		1.00
Lane Grp Cap(c), veh/h	893	0	836	49	399	366	118	0	113	309	0	684
V/C Ratio(X)	0.84	0.00	0.51	0.49	0.62	0.64	0.55	0.00	0.23	0.68	0.00	1.07
Avail Cap(c_a), veh/h	1018	0	1687	170	1278	1171	170	0	162	309	0	684
HCM Platoon Ratio	1.00	1.00	1.00	1.00	1.00	1.00	1.00	1.00	1.00	1.00	1.00	1.00
Upstream Filter(I)	1.00	0.00	1.00	1.00	1.00	1.00	1.00	0.00	1.00	1.00	0.00	1.00
Uniform Delay (d), s/veh	20.3	0.0	11.1	27.6	20.2	20.3	26.1	0.0	25.5	22.4	0.0	16.4
Incr Delay (d2), s/veh	5.9	0.0	0.5	7.3	1.6	1.9	3.9	0.0	1.0	6.0	0.0	54.7
Initial Q Delay(d3),s/veh	0.0	0.0	0.0	0.0	0.0	0.0	0.0	0.0	0.0	0.0	0.0	0.0
%ile BackOfQ(50%),veh/ln	4.8	0.0	3.1	0.4	2.8	2.7	0.9	0.0	0.4	2.9	0.0	17.9
Unsig. Movement Delay, s/veh												
LnGrp Delay(d),s/veh	26.2	0.0	11.6	34.9	21.8	22.2	30.0	0.0	26.6	28.4	0.0	71.1
LnGrp LOS	C	A	B	C	C	C	C	A	C	C	A	F
Approach Vol, veh/h		1179			508			91				943
Approach Delay, s/veh		21.0			22.6			29.0				61.5
Approach LOS		C			C			C				E
Timer - Assigned Phs	1	2		4	5	6		8				
Phs Duration (G+Y+Rc), s	5.6	30.3		14.0	18.9	17.0		7.8				
Change Period (Y+Rc), s	4.0	4.0		4.0	4.0	4.0		4.0				
Max Green Setting (Gmax), s	5.5	53.0		10.0	17.0	41.5		5.5				
Max Q Clear Time (g_c+1), s	2.8	11.5		12.0	13.9	9.6		4.0				
Green Ext Time (p_c), s	0.0	2.7		0.0	1.0	3.0		0.0				
<b>Intersection Summary</b>												
HCM 6th Ctrl Delay				35.6								
HCM 6th LOS				D								

HCM 6th Signalized Intersection Summary  
 3: US 101 NB Off-Ramp & Shiloh Road

2028 Opening Year No Project Conditions  
 Timing Plan: Saturday Midday Peak



Movement	EBT	EBR	WBL	WBT	NBL	NBR
Lane Configurations	↑↑			↑	↘	↗
Traffic Volume (veh/h)	442	0	0	773	401	658
Future Volume (veh/h)	442	0	0	773	401	658
Initial Q (Qb), veh	0	0	0	0	0	0
Ped-Bike Adj(A_pbT)		1.00	1.00		1.00	1.00
Parking Bus, Adj	1.00	1.00	1.00	1.00	1.00	1.00
Work Zone On Approach	No			No	No	
Adj Sat Flow, veh/h/ln	1870	0	0	1870	1870	1870
Adj Flow Rate, veh/h	486	0	0	869	422	693
Peak Hour Factor	0.91	0.91	0.89	0.89	0.95	0.95
Percent Heavy Veh, %	2	0	0	2	2	2
Cap, veh/h	1821	0	0	958	587	920
Arrive On Green	0.51	0.00	0.00	0.51	0.33	0.33
Sat Flow, veh/h	3741	0	0	1870	1781	2790
Grp Volume(v), veh/h	486	0	0	869	422	693
Grp Sat Flow(s),veh/h/ln	1777	0	0	1870	1781	1395
Q Serve(g_s), s	4.4	0.0	0.0	24.1	11.9	12.6
Cycle Q Clear(g_c), s	4.4	0.0	0.0	24.1	11.9	12.6
Prop In Lane		0.00	0.00		1.00	1.00
Lane Grp Cap(c), veh/h	1821	0	0	958	587	920
V/C Ratio(X)	0.27	0.00	0.00	0.91	0.72	0.75
Avail Cap(c_a), veh/h	2028	0	0	1067	954	1494
HCM Platoon Ratio	1.00	1.00	1.00	1.00	1.00	1.00
Upstream Filter(I)	1.00	0.00	0.00	1.00	1.00	1.00
Uniform Delay (d), s/veh	7.8	0.0	0.0	12.6	16.8	17.0
Incr Delay (d2), s/veh	0.1	0.0	0.0	10.4	1.7	1.3
Initial Q Delay(d3),s/veh	0.0	0.0	0.0	0.0	0.0	0.0
%ile BackOfQ(50%),veh/ln	1.3	0.0	0.0	9.9	4.5	3.7
Unsig. Movement Delay, s/veh						
LnGrp Delay(d),s/veh	7.9	0.0	0.0	23.0	18.4	18.3
LnGrp LOS	A	A	A	C	B	B
Approach Vol, veh/h	486			869	1115	
Approach Delay, s/veh	7.9			23.0	18.4	
Approach LOS	A			C	B	
Timer - Assigned Phs		2			6	8
Phs Duration (G+Y+Rc), s		33.7			33.7	23.3
Change Period (Y+Rc), s		4.5			4.5	4.5
Max Green Setting (Gmax), s		32.5			32.5	30.5
Max Q Clear Time (g_c+I1), s		6.4			26.1	14.6
Green Ext Time (p_c), s		3.1			3.1	4.2
<b>Intersection Summary</b>						
HCM 6th Ctrl Delay			18.0			
HCM 6th LOS			B			

HCM Signalized Intersection Capacity Analysis  
4: Shiloh Road & US 101 SB Off-Ramp

2028 Opening Year No Project Conditions  
Timing Plan: Saturday Midday Peak



Movement	EBL	EBT	WBT	WBR	SBL	SBR
Lane Configurations		↑	↑		↘	↗
Traffic Volume (vph)	0	318	600	0	212	174
Future Volume (vph)	0	318	600	0	212	174
Ideal Flow (vphpl)	1900	1900	1900	1900	1900	1900
Total Lost time (s)		4.5	4.5		4.5	4.5
Lane Util. Factor		1.00	1.00		1.00	1.00
Frbp, ped/bikes		1.00	1.00		1.00	1.00
Flpb, ped/bikes		1.00	1.00		1.00	1.00
Frt		1.00	1.00		1.00	0.85
Flt Protected		1.00	1.00		0.95	1.00
Satd. Flow (prot)		1863	1863		1770	1583
Flt Permitted		1.00	1.00		0.95	1.00
Satd. Flow (perm)		1863	1863		1770	1583
Peak-hour factor, PHF	0.96	0.96	0.96	0.96	0.68	0.68
Adj. Flow (vph)	0	331	625	0	312	256
RTOR Reduction (vph)	0	0	0	0	0	168
Lane Group Flow (vph)	0	331	625	0	312	88
Confl. Bikes (#/hr)				2		
Turn Type		NA	NA		Perm	Perm
Protected Phases		2	6			
Permitted Phases					4	4
Actuated Green, G (s)		20.8	20.8		15.7	15.7
Effective Green, g (s)		20.8	20.8		15.7	15.7
Actuated g/C Ratio		0.46	0.46		0.35	0.35
Clearance Time (s)		4.5	4.5		4.5	4.5
Vehicle Extension (s)		3.0	3.0		3.0	3.0
Lane Grp Cap (vph)		851	851		610	546
v/s Ratio Prot		0.18	c0.34			
v/s Ratio Perm					c0.18	0.06
v/c Ratio		0.39	0.73		0.51	0.16
Uniform Delay, d1		8.2	10.1		11.9	10.3
Progression Factor		1.00	1.00		1.00	1.00
Incremental Delay, d2		0.3	3.3		0.7	0.1
Delay (s)		8.5	13.4		12.6	10.5
Level of Service		A	B		B	B
Approach Delay (s)		8.5	13.4		11.6	
Approach LOS		A	B		B	
<b>Intersection Summary</b>						
HCM 2000 Control Delay			11.7		HCM 2000 Level of Service	B
HCM 2000 Volume to Capacity ratio			0.64			
Actuated Cycle Length (s)			45.5		Sum of lost time (s)	9.0
Intersection Capacity Utilization			102.3%		ICU Level of Service	G
Analysis Period (min)			15			
c Critical Lane Group						

Intersection						
Int Delay, s/veh	2.2					
Movement	EBT	EBR	WBL	WBT	NBL	NBR
Lane Configurations	↑↑		↘	↑	↘	↘
Traffic Vol, veh/h	612	23	92	676	18	89
Future Vol, veh/h	612	23	92	676	18	89
Conflicting Peds, #/hr	0	0	0	0	1	0
Sign Control	Free	Free	Free	Free	Stop	Stop
RT Channelized	-	None	-	None	-	None
Storage Length	-	-	68	-	0	0
Veh in Median Storage, #	0	-	-	0	0	-
Grade, %	0	-	-	0	0	-
Peak Hour Factor	92	92	87	87	78	78
Heavy Vehicles, %	2	2	2	2	2	2
Mvmt Flow	665	25	106	777	23	114

Major/Minor	Major1	Major2	Minor1		
Conflicting Flow All	0	0	690	0	1668 345
Stage 1	-	-	-	-	678 -
Stage 2	-	-	-	-	990 -
Critical Hdwy	-	-	4.13	-	6.63 6.93
Critical Hdwy Stg 1	-	-	-	-	5.83 -
Critical Hdwy Stg 2	-	-	-	-	5.43 -
Follow-up Hdwy	-	-	2.219	-	3.519 3.319
Pot Cap-1 Maneuver	-	-	903	-	96 652
Stage 1	-	-	-	-	467 -
Stage 2	-	-	-	-	359 -
Platoon blocked, %	-	-	-	-	-
Mov Cap-1 Maneuver	-	-	903	-	85 652
Mov Cap-2 Maneuver	-	-	-	-	85 -
Stage 1	-	-	-	-	467 -
Stage 2	-	-	-	-	317 -

Approach	EB	WB	NB
HCM Control Delay, s	0	1.1	20.2
HCM LOS			C

Minor Lane/Major Mvmt	NBLn1	NBLn2	EBT	EBR	WBL	WBT
Capacity (veh/h)	85	652	-	-	903	-
HCM Lane V/C Ratio	0.271	0.175	-	-	0.117	-
HCM Control Delay (s)	62.4	11.7	-	-	9.5	-
HCM Lane LOS	F	B	-	-	A	-
HCM 95th %tile Q(veh)	1	0.6	-	-	0.4	-



HCM Signalized Intersection Capacity Analysis  
6: Conde Lane & Shiloh Road

2028 Opening Year No Project Conditions

Timing Plan: Saturday Midday Peak

Movement	EBL	EBT	EBR	WBL	WBT	WBR	NBL	NBT	NBR	SBL	SBT	SBR
Lane Configurations												
Traffic Volume (vph)	33	402	1	10	448	232	1	0	7	224	0	32
Future Volume (vph)	33	402	1	10	448	232	1	0	7	224	0	32
Ideal Flow (vphp)	1900	1900	1900	1900	1900	1900	1900	1900	1900	1900	1900	1900
Total Lost time (s)	4.5	4.5		4.5	4.5			4.5			4.5	4.5
Lane Util. Factor	1.00	0.95		1.00	0.95			1.00			1.00	1.00
Frbp, ped/bikes	1.00	1.00		1.00	0.99			1.00			1.00	1.00
Flpb, ped/bikes	1.00	1.00		1.00	1.00			1.00			1.00	1.00
Frt	1.00	1.00		1.00	0.95			0.88			1.00	0.85
Flt Protected	0.95	1.00		0.95	1.00			0.99			0.95	1.00
Satd. Flow (prot)	1770	3538		1770	3333			1636			1770	1583
Flt Permitted	0.95	1.00		0.95	1.00			0.99			0.95	1.00
Satd. Flow (perm)	1770	3538		1770	3333			1636			1770	1583
Peak-hour factor, PHF	0.96	0.96	0.96	0.91	0.91	0.91	0.58	0.58	0.58	0.78	0.78	0.78
Adj. Flow (vph)	34	419	1	11	492	255	2	0	12	287	0	41
RTOR Reduction (vph)	0	0	0	0	62	0	0	14	0	0	0	0
Lane Group Flow (vph)	34	420	0	11	685	0	0	0	0	0	287	41
Confl. Bikes (#/hr)							2					
Turn Type	Prot	NA		Prot	NA		Split	NA		Split	NA	custom
Protected Phases	5	2		1	6		7	7		4	4	
Permitted Phases												6
Actuated Green, G (s)	2.4	19.1		1.0	17.7			1.2			12.4	17.7
Effective Green, g (s)	2.4	19.1		1.0	17.7			1.2			12.4	17.7
Actuated g/C Ratio	0.05	0.37		0.02	0.34			0.02			0.24	0.34
Clearance Time (s)	4.5	4.5		4.5	4.5			4.5			4.5	4.5
Vehicle Extension (s)	3.0	3.0		3.0	3.0			3.0			3.0	3.0
Lane Grp Cap (vph)	82	1307		34	1141			37			424	541
v/s Ratio Prot	c0.02	0.12		0.01	c0.21			c0.00			c0.16	
v/s Ratio Perm												0.03
v/c Ratio	0.41	0.32		0.32	0.60			0.01			0.68	0.08
Uniform Delay, d1	24.0	11.7		25.0	14.1			24.7			17.8	11.5
Progression Factor	1.00	1.00		1.00	1.00			1.00			1.00	1.00
Incremental Delay, d2	3.4	0.1		5.5	0.9			0.1			4.3	0.1
Delay (s)	27.3	11.8		30.5	15.0			24.8			22.1	11.5
Level of Service	C	B		C	B			C			C	B
Approach Delay (s)		13.0			15.2			24.8			20.8	
Approach LOS		B			B			C			C	
<b>Intersection Summary</b>												
HCM 2000 Control Delay			15.8			HCM 2000 Level of Service				B		
HCM 2000 Volume to Capacity ratio			0.59									
Actuated Cycle Length (s)			51.7			Sum of lost time (s)			18.0			
Intersection Capacity Utilization			54.0%			ICU Level of Service				A		
Analysis Period (min)			15									
c	Critical Lane Group											

HCM 6th TWSC  
7: Entrance 1/Gridley Drive & Shiloh Road

2028 Opening Year No Project Conditions  
Timing Plan: Saturday Midday Peak

Intersection												
Int Delay, s/veh	1.6											
Movement	EBL	EBT	EBR	WBL	WBT	WBR	NBL	NBT	NBR	SBL	SBT	SBR
Lane Configurations		↕			↕		↕	↕			↕	
Traffic Vol, veh/h	23	121	0	0	105	0	0	0	0	0	0	20
Future Vol, veh/h	23	121	0	0	105	0	0	0	0	0	0	20
Conflicting Peds, #/hr	1	0	0	0	0	0	0	0	0	0	0	0
Sign Control	Free	Free	Free	Free	Free	Free	Stop	Stop	Stop	Stop	Stop	Stop
RT Channelized	-	-	None	-	-	None	-	-	None	-	-	None
Storage Length	-	-	-	-	-	-	0	-	-	-	-	-
Veh in Median Storage, #	-	0	-	-	0	-	-	0	-	-	0	-
Grade, %	-	0	-	-	0	-	-	0	-	-	0	-
Peak Hour Factor	93	93	93	88	88	88	100	100	100	56	56	56
Heavy Vehicles, %	2	2	2	2	2	2	2	2	2	2	2	2
Mvmt Flow	25	130	0	0	119	0	0	0	0	0	0	36

Major/Minor	Major1			Major2			Minor1			Minor2		
Conflicting Flow All	120	0	0	130	0	0	317	300	130	300	300	120
Stage 1	-	-	-	-	-	-	180	180	-	120	120	-
Stage 2	-	-	-	-	-	-	137	120	-	180	180	-
Critical Hdwy	4.12	-	-	4.12	-	-	7.12	6.52	6.22	7.12	6.52	6.22
Critical Hdwy Stg 1	-	-	-	-	-	-	6.12	5.52	-	6.12	5.52	-
Critical Hdwy Stg 2	-	-	-	-	-	-	6.12	5.52	-	6.12	5.52	-
Follow-up Hdwy	2.218	-	-	2.218	-	-	3.518	4.018	3.318	3.518	4.018	3.318
Pot Cap-1 Maneuver	1468	-	-	1455	-	-	636	612	920	652	612	931
Stage 1	-	-	-	-	-	-	822	750	-	884	796	-
Stage 2	-	-	-	-	-	-	866	796	-	822	750	-
Platoon blocked, %		-	-		-	-						
Mov Cap-1 Maneuver	1467	-	-	1455	-	-	603	600	920	642	600	930
Mov Cap-2 Maneuver	-	-	-	-	-	-	603	600	-	642	600	-
Stage 1	-	-	-	-	-	-	807	737	-	867	795	-
Stage 2	-	-	-	-	-	-	833	795	-	807	737	-

Approach	EB			WB			NB			SB		
HCM Control Delay, s	1.2			0			0			9		
HCM LOS							A			A		

Minor Lane/Major Mvmt	NBLn1	NBLn2	EBL	EBT	EBR	WBL	WBT	WBR	SBLn1
Capacity (veh/h)	-	-	1467	-	-	1455	-	-	930
HCM Lane V/C Ratio	-	-	0.017	-	-	-	-	-	0.038
HCM Control Delay (s)	0	0	7.5	0	-	0	-	-	9
HCM Lane LOS	A	A	A	A	-	A	-	-	A
HCM 95th %tile Q(veh)	-	-	0.1	-	-	0	-	-	0.1

HCM 6th TWSC  
8: Old Redwood Hwy & Entrance 1

2028 Opening Year No Project Conditions  
Timing Plan: Saturday Midday Peak

Intersection												
Int Delay, s/veh	0.1											
Movement	EBL	EBT	EBR	WBL	WBT	WBR	NBL	NBT	NBR	SBL	SBT	SBR
Lane Configurations		↕		↕	↕			↕		↕	↕	
Traffic Vol, veh/h	1	0	2	0	0	0	1	459	0	0	389	5
Future Vol, veh/h	1	0	2	0	0	0	1	459	0	0	389	5
Conflicting Peds, #/hr	0	0	0	0	0	0	1	0	4	4	0	1
Sign Control	Stop	Stop	Stop	Stop	Stop	Stop	Free	Free	Free	Free	Free	Free
RT Channelized	-	-	None	-	-	None	-	-	None	-	-	None
Storage Length	-	-	-	0	-	-	-	-	-	50	-	-
Veh in Median Storage, #	-	0	-	-	0	-	-	0	-	-	0	-
Grade, %	-	0	-	-	0	-	-	0	-	-	0	-
Peak Hour Factor	38	38	38	100	100	100	94	94	94	93	93	93
Heavy Vehicles, %	2	2	2	2	2	2	2	2	2	2	2	2
Mvmt Flow	3	0	5	0	0	0	1	488	0	0	418	5

Major/Minor	Minor2		Minor1		Major1		Major2					
Conflicting Flow All	912	916	422	917	918	492	424	0	0	492	0	0
Stage 1	422	422	-	494	494	-	-	-	-	-	-	-
Stage 2	490	494	-	423	424	-	-	-	-	-	-	-
Critical Hdwy	7.12	6.52	6.22	7.12	6.52	6.22	4.12	-	-	4.12	-	-
Critical Hdwy Stg 1	6.12	5.52	-	6.12	5.52	-	-	-	-	-	-	-
Critical Hdwy Stg 2	6.12	5.52	-	6.12	5.52	-	-	-	-	-	-	-
Follow-up Hdwy	3.518	4.018	3.318	3.518	4.018	3.318	2.218	-	-	2.218	-	-
Pot Cap-1 Maneuver	255	272	632	253	272	577	1135	-	-	1071	-	-
Stage 1	609	588	-	557	546	-	-	-	-	-	-	-
Stage 2	560	546	-	609	587	-	-	-	-	-	-	-
Platoon blocked, %								-	-	-	-	-
Mov Cap-1 Maneuver	254	270	631	250	270	575	1134	-	-	1067	-	-
Mov Cap-2 Maneuver	254	270	-	250	270	-	-	-	-	-	-	-
Stage 1	608	587	-	554	543	-	-	-	-	-	-	-
Stage 2	559	543	-	604	586	-	-	-	-	-	-	-

Approach	EB	WB	NB	SB
HCM Control Delay, s	13.7	0	0	0
HCM LOS	B	A		

Minor Lane/Major Mvmt	NBL	NBT	NBR	EBLn1	WBLn1	WBLn2	SBL	SBT	SBR
Capacity (veh/h)	1134	-	-	422	-	-	1067	-	-
HCM Lane V/C Ratio	0.001	-	-	0.019	-	-	-	-	-
HCM Control Delay (s)	8.2	0	-	13.7	0	0	0	-	-
HCM Lane LOS	A	A	-	B	A	A	A	-	-
HCM 95th %tile Q(veh)	0	-	-	0.1	-	-	0	-	-

Intersection						
Int Delay, s/veh	0					
Movement	EBT	EBR	WBL	WBT	NBL	NBR
Lane Configurations	↔			↔	↔	↔
Traffic Vol, veh/h	105	0	0	98	0	0
Future Vol, veh/h	105	0	0	98	0	0
Conflicting Peds, #/hr	0	1	0	0	0	0
Sign Control	Free	Free	Free	Free	Stop	Stop
RT Channelized	-	None	-	None	-	None
Storage Length	-	-	-	-	0	0
Veh in Median Storage, #	0	-	-	0	0	-
Grade, %	0	-	-	0	0	-
Peak Hour Factor	88	88	80	80	100	100
Heavy Vehicles, %	2	2	2	2	2	2
Mvmt Flow	119	0	0	123	0	0

Major/Minor	Major1	Major2	Minor1		
Conflicting Flow All	0	0	120	0	243
Stage 1	-	-	-	-	120
Stage 2	-	-	-	-	123
Critical Hdwy	-	-	4.12	-	6.42
Critical Hdwy Stg 1	-	-	-	-	5.42
Critical Hdwy Stg 2	-	-	-	-	5.42
Follow-up Hdwy	-	-	2.218	-	3.518
Pot Cap-1 Maneuver	-	-	1468	-	745
Stage 1	-	-	-	-	905
Stage 2	-	-	-	-	902
Platoon blocked, %	-	-	-	-	-
Mov Cap-1 Maneuver	-	-	1467	-	744
Mov Cap-2 Maneuver	-	-	-	-	744
Stage 1	-	-	-	-	904
Stage 2	-	-	-	-	902

Approach	EB	WB	NB
HCM Control Delay, s	0	0	0
HCM LOS			A

Minor Lane/Major Mvmt	NBLn1	NBLn2	EBT	EBR	WBL	WBT
Capacity (veh/h)	-	-	-	-	1467	-
HCM Lane V/C Ratio	-	-	-	-	-	-
HCM Control Delay (s)	0	0	-	-	0	-
HCM Lane LOS	A	A	-	-	A	-
HCM 95th %tile Q(veh)	-	-	-	-	0	-

HCM 6th Signalized Intersection Summary 2028 Opening Year No Project Conditions  
 10: US 101 NB Off Ramp/Lakewood Drive & Old Redwood Highway Timing Plan: Saturday Midday Peak



Movement	EBL	EBT	EBR	WBL	WBT	WBR	NBL	NBT	NBR	SBL	SBT	SBR
Lane Configurations	↔↔	↑			↑↑		↔	↔↔		↔↔		↔
Traffic Volume (veh/h)	287	313	0	0	502	276	320	303	142	244	0	700
Future Volume (veh/h)	287	313	0	0	502	276	320	303	142	244	0	700
Initial Q (Qb), veh	0	0	0	0	0	0	0	0	0	0	0	0
Ped-Bike Adj(A_pbT)	1.00		1.00	1.00		0.99	1.00		1.00	1.00		1.00
Parking Bus, Adj	1.00	1.00	1.00	1.00	1.00	1.00	1.00	1.00	1.00	1.00	1.00	1.00
Work Zone On Approach		No			No			No			No	
Adj Sat Flow, veh/h/ln	1870	1870	0	0	1870	1870	1870	1870	1870	1870	0	1870
Adj Flow Rate, veh/h	302	329	0	0	564	310	260	402	145	277	0	0
Peak Hour Factor	0.95	0.95	0.95	0.89	0.89	0.89	0.98	0.98	0.98	0.88	0.88	0.88
Percent Heavy Veh, %	2	2	0	0	2	2	2	2	2	2	0	2
Cap, veh/h	397	1173	0	0	975	535	418	618	220	0	0	0
Arrive On Green	0.11	0.63	0.00	0.00	0.44	0.44	0.23	0.23	0.23	0.00	0.00	0.00
Sat Flow, veh/h	3456	1870	0	0	2294	1208	1781	2633	938		0	
Grp Volume(v), veh/h	302	329	0	0	455	419	260	284	263		0.0	
Grp Sat Flow(s),veh/h/ln	1728	1870	0	0	1777	1631	1781	1870	1700			
Q Serve(g_s), s	5.5	5.2	0.0	0.0	12.5	12.5	8.5	8.9	9.1			
Cycle Q Clear(g_c), s	5.5	5.2	0.0	0.0	12.5	12.5	8.5	8.9	9.1			
Prop In Lane	1.00		0.00	0.00		0.74	1.00		0.55			
Lane Grp Cap(c), veh/h	397	1173	0	0	787	723	418	439	399			
V/C Ratio(X)	0.76	0.28	0.00	0.00	0.58	0.58	0.62	0.65	0.66			
Avail Cap(c_a), veh/h	398	1173	0	0	787	723	799	839	763			
HCM Platoon Ratio	1.00	1.00	1.00	1.00	1.00	1.00	1.00	1.00	1.00			
Upstream Filter(I)	1.00	1.00	0.00	0.00	1.00	1.00	1.00	1.00	1.00			
Uniform Delay (d), s/veh	27.9	5.5	0.0	0.0	13.6	13.6	22.3	22.5	22.5			
Incr Delay (d2), s/veh	8.3	0.6	0.0	0.0	3.1	3.4	1.5	1.6	1.9			
Initial Q Delay(d3),s/veh	0.0	0.0	0.0	0.0	0.0	0.0	0.0	0.0	0.0			
%ile BackOfQ(50%),veh/ln	2.6	1.6	0.0	0.0	4.9	4.6	3.5	3.9	3.6			
Unsig. Movement Delay, s/veh												
LnGrp Delay(d),s/veh	36.2	6.1	0.0	0.0	16.7	16.9	23.8	24.1	24.4			
LnGrp LOS	D	A	A	A	B	B	C	C	C			
Approach Vol, veh/h		631			874			807				
Approach Delay, s/veh		20.5			16.8			24.1				
Approach LOS		C			B			C				
Timer - Assigned Phs		2			5	6		8				
Phs Duration (G+Y+Rc), s		45.3			12.0	33.3		19.8				
Change Period (Y+Rc), s		4.5			4.5	4.5		4.5				
Max Green Setting (Gmax), s		40.8			7.5	28.8		29.2				
Max Q Clear Time (g_c+I1), s		7.2			7.5	14.5		11.1				
Green Ext Time (p_c), s		2.0			0.0	4.8		4.0				

**Intersection Summary**

HCM 6th Ctrl Delay	20.4
HCM 6th LOS	C

**Notes**

User approved volume balancing among the lanes for turning movement.  
 Unsignalized Delay for [SBR] is excluded from calculations of the approach delay and intersection delay.

HCM 6th Signalized Intersection Summary

2028 Opening Year No Project Conditions

12: US 101 SB On Ramp/US 101 SB Off Ramp & Old Redwood Highway Timing Plan: Saturday Midday Peak



Movement	EBL	EBT	EBR	WBL	WBT	WBR	NBL	NBT	NBR	SBL	SBT	SBR
Lane Configurations		↑↑	↗	↘	↑↑					↘	↕	
Traffic Volume (veh/h)	0	550	419	487	818	0	0	0	0	151	1	87
Future Volume (veh/h)	0	550	419	487	818	0	0	0	0	151	1	87
Initial Q (Qb), veh	0	0	0	0	0	0				0	0	0
Ped-Bike Adj(A_pbT)	1.00		0.98	1.00		1.00				1.00		1.00
Parking Bus, Adj	1.00	1.00	1.00	1.00	1.00	1.00				1.00	1.00	1.00
Work Zone On Approach		No			No						No	
Adj Sat Flow, veh/h/ln	0	1870	1870	1870	1870	0				1870	1870	1870
Adj Flow Rate, veh/h	0	567	432	507	852	0				166	63	0
Peak Hour Factor	0.97	0.97	0.97	0.96	0.96	0.96				0.72	0.72	0.72
Percent Heavy Veh, %	0	2	2	2	2	0				2	2	2
Cap, veh/h	0	1418	620	473	2591	0				253	265	
Arrive On Green	0.00	0.40	0.40	0.27	0.73	0.00				0.14	0.14	0.00
Sat Flow, veh/h	0	3647	1555	1781	3647	0				1781	1870	0
Grp Volume(v), veh/h	0	567	432	507	852	0				166	63	0
Grp Sat Flow(s),veh/h/ln	0	1777	1555	1781	1777	0				1781	1870	0
Q Serve(g_s), s	0.0	8.0	16.1	18.5	6.0	0.0				6.1	2.1	0.0
Cycle Q Clear(g_c), s	0.0	8.0	16.1	18.5	6.0	0.0				6.1	2.1	0.0
Prop In Lane	0.00		1.00	1.00		0.00				1.00		0.00
Lane Grp Cap(c), veh/h	0	1418	620	473	2591	0				253	265	
V/C Ratio(X)	0.00	0.40	0.70	1.07	0.33	0.00				0.66	0.24	
Avail Cap(c_a), veh/h	0	1418	620	473	2591	0				261	274	
HCM Platoon Ratio	1.00	1.00	1.00	1.00	1.00	1.00				1.00	1.00	1.00
Upstream Filter(I)	0.00	1.00	1.00	1.00	1.00	0.00				1.00	1.00	0.00
Uniform Delay (d), s/veh	0.0	15.0	17.4	25.6	3.4	0.0				28.3	26.6	0.0
Incr Delay (d2), s/veh	0.0	0.8	6.4	62.0	0.3	0.0				5.7	0.5	0.0
Initial Q Delay(d3),s/veh	0.0	0.0	0.0	0.0	0.0	0.0				0.0	0.0	0.0
%ile BackOfQ(50%),veh/ln	0.0	3.0	6.2	15.3	1.3	0.0				2.9	0.9	0.0
Unsig. Movement Delay, s/veh												
LnGrp Delay(d),s/veh	0.0	15.8	23.8	87.6	3.7	0.0				34.0	27.0	0.0
LnGrp LOS	A	B	C	F	A	A				C	C	
Approach Vol, veh/h		999			1359						229	
Approach Delay, s/veh		19.3			35.0						32.1	
Approach LOS		B			D						C	
Timer - Assigned Phs		2			5	6		8				
Phs Duration (G+Y+Rc), s		55.3			23.0	32.3		14.4				
Change Period (Y+Rc), s		4.5			4.5	4.5		4.5				
Max Green Setting (Gmax), s		50.8			18.5	27.8		10.2				
Max Q Clear Time (g_c+I1), s		8.0			20.5	18.1		8.1				
Green Ext Time (p_c), s		7.0			0.0	3.8		0.2				

Intersection Summary

HCM 6th Ctrl Delay	28.7
HCM 6th LOS	C

Notes

- User approved volume balancing among the lanes for turning movement.
- User approved ignoring U-Turning movement.
- Unsignalized Delay for [SBR] is excluded from calculations of the approach delay and intersection delay.

Queues  
1: Old Redwood Hwy & Shiloh Road

2028 Opening Year No Project Conditions  
Timing Plan: A.M. PEAK



Lane Group	EBL	EBT	EBR	WBT	WBR	NBL	NBT	NBR	SBL	SBT	SBR
Lane Group Flow (vph)	169	148	119	97	15	100	153	42	18	309	245
v/c Ratio	0.44	0.37	0.27	0.33	0.04	0.34	0.20	0.06	0.10	0.56	0.44
Control Delay	32.1	30.7	8.2	34.6	0.2	34.8	16.6	1.5	38.9	27.8	14.0
Queue Delay	0.0	0.0	0.0	0.0	0.0	0.0	0.0	0.0	0.0	0.0	0.0
Total Delay	32.1	30.7	8.2	34.6	0.2	34.8	16.6	1.5	38.9	27.8	14.0
Queue Length 50th (ft)	64	55	0	37	0	38	35	0	7	112	36
Queue Length 95th (ft)	135	120	33	101	0	105	105	7	31	223	105
Internal Link Dist (ft)		1709		528			668			695	
Turn Bay Length (ft)	375		140		50	200		98	130		93
Base Capacity (vph)	947	997	903	1135	1018	467	1263	1098	193	1089	962
Starvation Cap Reductn	0	0	0	0	0	0	0	0	0	0	0
Spillback Cap Reductn	0	0	0	0	0	0	0	0	0	0	0
Storage Cap Reductn	0	0	0	0	0	0	0	0	0	0	0
Reduced v/c Ratio	0.18	0.15	0.13	0.09	0.01	0.21	0.12	0.04	0.09	0.28	0.25

Intersection Summary

Queues

2028 Opening Year No Project Conditions

2: Shiloh Road & Hembree Ln

Timing Plan: A.M. PEAK

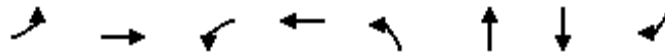

Lane Group	EBL	EBT	WBL	WBT	NBL	NBT	SBT	SBR
Lane Group Flow (vph)	394	381	19	415	39	18	95	439
v/c Ratio	0.51	0.37	0.09	0.43	0.19	0.09	0.33	0.47
Control Delay	24.0	8.8	32.5	16.1	33.0	23.4	29.6	3.2
Queue Delay	0.0	0.0	0.0	0.0	0.0	0.0	0.0	0.0
Total Delay	24.0	8.8	32.5	16.1	33.0	23.4	29.6	3.2
Queue Length 50th (ft)	58	67	6	56	12	2	28	0
Queue Length 95th (ft)	144	151	32	95	53	25	98	49
Internal Link Dist (ft)		222		1709		136	301	
Turn Bay Length (ft)			100					
Base Capacity (vph)	1217	1646	203	2714	203	203	371	1082
Starvation Cap Reductn	0	0	0	0	0	0	0	0
Spillback Cap Reductn	0	0	0	0	0	0	0	0
Storage Cap Reductn	0	0	0	0	0	0	0	0
Reduced v/c Ratio	0.32	0.23	0.09	0.15	0.19	0.09	0.26	0.41

Intersection Summary



Queues  
3: US 101 NB Off-Ramp & Shiloh Road

2028 Opening Year No Project Conditions  
Timing Plan: A.M. PEAK

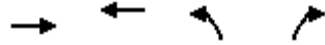

Lane Group	EBT	WBT	NBL	NBR
Lane Group Flow (vph)	303	682	647	562
v/c Ratio	0.20	0.84	0.85	0.37
Control Delay	11.7	27.6	30.0	2.1
Queue Delay	0.0	0.0	0.0	0.0
Total Delay	11.7	27.6	30.0	2.1
Queue Length 50th (ft)	40	247	237	0
Queue Length 95th (ft)	63	#435	293	10
Internal Link Dist (ft)	106	291	689	
Turn Bay Length (ft)				265
Base Capacity (vph)	1934	1017	908	1704
Starvation Cap Reductn	0	0	0	0
Spillback Cap Reductn	0	0	0	0
Storage Cap Reductn	0	0	0	0
Reduced v/c Ratio	0.16	0.67	0.71	0.33

Intersection Summary

# 95th percentile volume exceeds capacity, queue may be longer.  
Queue shown is maximum after two cycles.

Queues  
4: Shiloh Road & US 101 SB Off-Ramp

2028 Opening Year No Project Conditions  
Timing Plan: A.M. PEAK

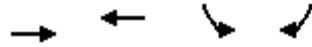

Lane Group	EBT	WBT	SBL	SBR
Lane Group Flow (vph)	287	743	100	189
v/c Ratio	0.23	0.59	0.24	0.36
Control Delay	4.3	7.6	16.8	5.9
Queue Delay	0.0	0.0	0.0	0.0
Total Delay	4.3	7.6	16.8	5.9
Queue Length 50th (ft)	23	83	17	0
Queue Length 95th (ft)	56	195	62	42
Internal Link Dist (ft)	145	226	406	
Turn Bay Length (ft)				275
Base Capacity (vph)	1863	1863	965	949
Starvation Cap Reductn	0	0	0	0
Spillback Cap Reductn	0	0	0	0
Storage Cap Reductn	0	0	0	0
Reduced v/c Ratio	0.15	0.40	0.10	0.20
<b>Intersection Summary</b>				

Queues  
6: Conde Lane & Shiloh Road

2028 Opening Year No Project Conditions  
Timing Plan: A.M. PEAK

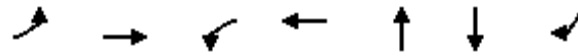

Lane Group	EBL	EBT	WBL	WBT	NBT	SBT	SBR
Lane Group Flow (vph)	29	393	12	744	34	272	47
v/c Ratio	0.08	0.27	0.03	0.56	0.07	0.56	0.08
Control Delay	25.4	10.6	25.7	12.9	0.3	30.0	13.3
Queue Delay	0.0	0.0	0.0	0.0	0.0	0.0	0.0
Total Delay	25.4	10.6	25.7	12.9	0.3	30.0	13.3
Queue Length 50th (ft)	5	21	2	36	0	46	4
Queue Length 95th (ft)	35	94	18	151	0	#247	32
Internal Link Dist (ft)		735		1001	338	442	
Turn Bay Length (ft)	90		127				40
Base Capacity (vph)	394	2978	350	2821	1289	483	1325
Starvation Cap Reductn	0	0	0	0	0	0	0
Spillback Cap Reductn	0	0	0	0	0	0	0
Storage Cap Reductn	0	0	0	0	0	0	0
Reduced v/c Ratio	0.07	0.13	0.03	0.26	0.03	0.56	0.04

Intersection Summary

# 95th percentile volume exceeds capacity, queue may be longer.  
Queue shown is maximum after two cycles.

Queues

2028 Opening Year No Project Conditions

10: US 101 NB Off Ramp/Lakewood Drive & Old Redwood Highway

Timing Plan: A.M. PEAK



Lane Group	EBL	EBT	WBT	NBL	NBT	SBL	SBR
Lane Group Flow (vph)	204	200	809	221	446	151	683
v/c Ratio	0.54	0.21	0.66	0.61	0.59	0.50	0.86
Control Delay	40.3	12.5	24.4	34.9	27.7	41.8	24.5
Queue Delay	0.0	0.0	0.0	0.0	0.0	0.0	0.0
Total Delay	40.3	12.5	24.4	34.9	27.7	41.8	24.5
Queue Length 50th (ft)	49	50	163	107	97	37	181
Queue Length 95th (ft)	86	102	234	181	143	72	331
Internal Link Dist (ft)		146	537		636		
Turn Bay Length (ft)	155			270		120	
Base Capacity (vph)	393	952	1225	594	1222	305	800
Starvation Cap Reductn	0	0	0	0	0	0	0
Spillback Cap Reductn	0	0	0	0	0	0	0
Storage Cap Reductn	0	0	0	0	0	0	0
Reduced v/c Ratio	0.52	0.21	0.66	0.37	0.36	0.50	0.85

Intersection Summary

Queues

2028 Opening Year No Project Conditions

12: US 101 SB On Ramp/US 101 SB Off Ramp & Old Redwood Highway

Timing Plan: A.M. PEAK



Lane Group	EBT	EBR	WBL	WBT	SBL	SBT
Lane Group Flow (vph)	368	366	656	645	117	105
v/c Ratio	0.31	0.48	1.02	0.24	0.56	0.39
Control Delay	20.3	5.2	69.4	3.2	43.9	14.4
Queue Delay	0.0	0.0	0.0	0.0	0.0	0.0
Total Delay	20.3	5.2	69.4	3.2	43.9	14.4
Queue Length 50th (ft)	70	5	~338	40	58	6
Queue Length 95th (ft)	104	62	#544	54	101	43
Internal Link Dist (ft)	343			451		751
Turn Bay Length (ft)			250		420	
Base Capacity (vph)	1203	760	641	2663	210	270
Starvation Cap Reductn	0	0	0	0	0	0
Spillback Cap Reductn	0	0	0	0	0	0
Storage Cap Reductn	0	0	0	0	0	0
Reduced v/c Ratio	0.31	0.48	1.02	0.24	0.56	0.39

Intersection Summary

~ Volume exceeds capacity, queue is theoretically infinite.

Queue shown is maximum after two cycles.

# 95th percentile volume exceeds capacity, queue may be longer.

Queue shown is maximum after two cycles.

Queues  
1: Old Redwood Hwy & Shiloh Road

2028 Opening Year No Project Conditions

Timing Plan: P.M. Peak



Lane Group	EBL	EBT	EBR	WBT	WBR	NBL	NBT	NBR	SBL	SBT	SBR
Lane Group Flow (vph)	299	101	214	146	20	200	415	26	28	289	197
v/c Ratio	0.69	0.22	0.39	0.53	0.06	0.65	0.58	0.04	0.23	0.68	0.45
Control Delay	40.1	29.3	6.6	44.2	0.4	49.3	28.6	0.1	49.8	40.9	17.1
Queue Delay	0.0	0.0	0.0	0.0	0.0	0.0	0.0	0.0	0.0	0.0	0.0
Total Delay	40.1	29.3	6.6	44.2	0.4	49.3	28.6	0.1	49.8	40.9	17.1
Queue Length 50th (ft)	145	43	0	73	0	102	191	0	15	143	36
Queue Length 95th (ft)	280	100	56	159	0	#274	358	0	50	269	111
Internal Link Dist (ft)		1709		528			668			695	
Turn Bay Length (ft)	375		140		50	200		98	130		93
Base Capacity (vph)	646	680	713	833	761	307	969	841	127	780	713
Starvation Cap Reductn	0	0	0	0	0	0	0	0	0	0	0
Spillback Cap Reductn	0	0	0	0	0	0	0	0	0	0	0
Storage Cap Reductn	0	0	0	0	0	0	0	0	0	0	0
Reduced v/c Ratio	0.46	0.15	0.30	0.18	0.03	0.65	0.43	0.03	0.22	0.37	0.28

Intersection Summary

# 95th percentile volume exceeds capacity, queue may be longer.  
Queue shown is maximum after two cycles.

Queues

2028 Opening Year No Project Conditions

2: Shiloh Road & Hembree Ln

Timing Plan: P.M. Peak

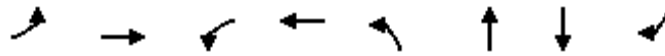

Lane Group	EBL	EBT	WBL	WBT	NBL	NBT	SBT	SBR
Lane Group Flow (vph)	745	507	24	561	65	26	215	595
v/c Ratio	0.79	0.48	0.15	0.58	0.42	0.16	0.75	0.65
Control Delay	32.8	10.4	35.2	17.5	42.1	24.4	48.7	9.5
Queue Delay	0.0	0.0	0.0	0.0	0.0	0.0	0.0	0.0
Total Delay	32.8	10.4	35.2	17.5	42.1	24.4	48.7	9.5
Queue Length 50th (ft)	135	102	9	76	24	4	80	30
Queue Length 95th (ft)	#356	224	37	108	#92	31	#269	#218
Internal Link Dist (ft)		222		1709		136	301	
Turn Bay Length (ft)			100					
Base Capacity (vph)	938	1528	156	2276	156	164	286	916
Starvation Cap Reductn	0	0	0	0	0	0	0	0
Spillback Cap Reductn	0	0	0	0	0	0	0	0
Storage Cap Reductn	0	0	0	0	0	0	0	0
Reduced v/c Ratio	0.79	0.33	0.15	0.25	0.42	0.16	0.75	0.65

Intersection Summary

# 95th percentile volume exceeds capacity, queue may be longer.  
 Queue shown is maximum after two cycles.

Queues  
3: US 101 NB Off-Ramp & Shiloh Road

2028 Opening Year No Project Conditions  
Timing Plan: P.M. Peak



Lane Group	EBT	WBT	NBL	NBR
Lane Group Flow (vph)	463	689	666	832
v/c Ratio	0.30	0.85	0.86	0.55
Control Delay	12.7	28.8	31.2	6.7
Queue Delay	0.0	0.0	0.0	0.0
Total Delay	12.7	28.8	31.2	6.7
Queue Length 50th (ft)	64	250	251	47
Queue Length 95th (ft)	94	#442	#461	98
Internal Link Dist (ft)	106	291	689	
Turn Bay Length (ft)				265
Base Capacity (vph)	1864	981	875	1640
Starvation Cap Reductn	0	0	0	0
Spillback Cap Reductn	0	0	0	0
Storage Cap Reductn	0	0	0	0
Reduced v/c Ratio	0.25	0.70	0.76	0.51

Intersection Summary

# 95th percentile volume exceeds capacity, queue may be longer.  
Queue shown is maximum after two cycles.



Queues  
4: Shiloh Road & US 101 SB Off-Ramp

2028 Opening Year No Project Conditions  
Timing Plan: P.M. Peak

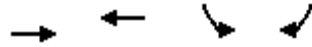

Lane Group	EBT	WBT	SBL	SBR
Lane Group Flow (vph)	560	744	151	157
v/c Ratio	0.53	0.71	0.38	0.33
Control Delay	7.6	10.7	19.2	6.2
Queue Delay	0.0	0.0	0.0	0.0
Total Delay	7.6	10.7	19.2	6.2
Queue Length 50th (ft)	60	93	28	0
Queue Length 95th (ft)	141	225	91	39
Internal Link Dist (ft)	145	226	406	
Turn Bay Length (ft)				275
Base Capacity (vph)	1863	1863	788	776
Starvation Cap Reductn	0	0	0	0
Spillback Cap Reductn	0	0	0	0
Storage Cap Reductn	0	0	0	0
Reduced v/c Ratio	0.30	0.40	0.19	0.20
<b>Intersection Summary</b>				

Queues  
6: Conde Lane & Shiloh Road

2028 Opening Year No Project Conditions  
Timing Plan: P.M. Peak

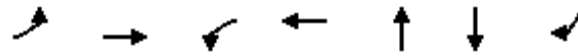

Lane Group	EBL	EBT	WBL	WBT	NBT	SBT	SBR
Lane Group Flow (vph)	90	610	10	1060	45	384	50
v/c Ratio	0.34	0.32	0.04	0.72	0.14	1.12	0.08
Control Delay	36.7	9.9	34.5	17.7	18.8	121.3	13.6
Queue Delay	0.0	0.0	0.0	0.0	0.0	0.0	0.0
Total Delay	36.7	9.9	34.5	17.7	18.8	121.3	13.6
Queue Length 50th (ft)	40	72	4	192	6	~252	14
Queue Length 95th (ft)	92	140	18	212	22	#467	33
Internal Link Dist (ft)		735		1001	338	442	
Turn Bay Length (ft)	90		127				40
Base Capacity (vph)	279	2440	248	2252	977	342	1055
Starvation Cap Reductn	0	0	0	0	0	0	0
Spillback Cap Reductn	0	0	0	0	0	0	0
Storage Cap Reductn	0	0	0	0	0	0	0
Reduced v/c Ratio	0.32	0.25	0.04	0.47	0.05	1.12	0.05

Intersection Summary

~ Volume exceeds capacity, queue is theoretically infinite.  
Queue shown is maximum after two cycles.

# 95th percentile volume exceeds capacity, queue may be longer.  
Queue shown is maximum after two cycles.

Queues

2028 Opening Year No Project Conditions

10: US 101 NB Off Ramp/Lakewood Drive & Old Redwood Highway

Timing Plan: P.M. Peak



Lane Group	EBL	EBT	WBT	NBL	NBT	SBL	SBR
Lane Group Flow (vph)	341	459	863	482	957	296	684
v/c Ratio	0.99	0.55	0.81	0.93	0.88	1.11	0.76
Control Delay	89.6	21.4	34.1	56.9	37.7	127.8	17.8
Queue Delay	0.0	0.0	0.0	0.0	0.0	0.0	0.0
Total Delay	89.6	21.4	34.1	56.9	37.7	127.8	17.8
Queue Length 50th (ft)	101	185	221	289	259	~100	186
Queue Length 95th (ft)	#179	265	295	#498	#381	#181	341
Internal Link Dist (ft)		146	537		636		
Turn Bay Length (ft)	155			270		120	
Base Capacity (vph)	343	832	1063	518	1082	267	896
Starvation Cap Reductn	0	0	0	0	0	0	0
Spillback Cap Reductn	0	0	0	0	0	0	0
Storage Cap Reductn	0	0	0	0	0	0	0
Reduced v/c Ratio	0.99	0.55	0.81	0.93	0.88	1.11	0.76

Intersection Summary

~ Volume exceeds capacity, queue is theoretically infinite.

Queue shown is maximum after two cycles.

# 95th percentile volume exceeds capacity, queue may be longer.

Queue shown is maximum after two cycles.

Queues

2028 Opening Year No Project Conditions

12: US 101 SB On Ramp/US 101 SB Off Ramp & Old Redwood Highway

Timing Plan: P.M. Peak



Lane Group	EBT	EBR	WBL	WBT	SBL	SBT
Lane Group Flow (vph)	648	462	488	1310	206	200
v/c Ratio	0.46	0.52	1.07	0.52	0.84	0.66
Control Delay	16.8	4.1	91.4	5.5	59.7	27.2
Queue Delay	0.0	0.0	0.0	0.0	0.0	0.0
Total Delay	16.8	4.1	91.4	5.5	59.7	27.2
Queue Length 50th (ft)	104	2	~239	107	92	44
Queue Length 95th (ft)	148	55	#403	141	#181	97
Internal Link Dist (ft)	343			451		751
Turn Bay Length (ft)			250		420	
Base Capacity (vph)	1411	893	455	2524	247	305
Starvation Cap Reductn	0	0	0	0	0	0
Spillback Cap Reductn	0	0	0	0	0	0
Storage Cap Reductn	0	0	0	0	0	0
Reduced v/c Ratio	0.46	0.52	1.07	0.52	0.83	0.66

Intersection Summary

~ Volume exceeds capacity, queue is theoretically infinite.

Queue shown is maximum after two cycles.

# 95th percentile volume exceeds capacity, queue may be longer.

Queue shown is maximum after two cycles.

Queues  
1: Old Redwood Hwy & Shiloh Road

2028 Opening Year No Project Conditions  
Timing Plan: Saturday Midday Peak



Lane Group	EBL	EBT	EBR	WBT	WBR	NBL	NBT	NBR	SBL	SBT	SBR
Lane Group Flow (vph)	175	93	221	125	20	215	286	29	25	237	263
v/c Ratio	0.53	0.27	0.47	0.45	0.06	0.61	0.36	0.04	0.18	0.60	0.55
Control Delay	34.1	29.0	8.0	35.9	0.4	39.3	18.9	0.1	40.4	33.6	13.5
Queue Delay	0.0	0.0	0.0	0.0	0.0	0.0	0.0	0.0	0.0	0.0	0.0
Total Delay	34.1	29.0	8.0	35.9	0.4	39.3	18.9	0.1	40.4	33.6	13.5
Queue Length 50th (ft)	69	35	0	50	0	85	73	0	10	92	26
Queue Length 95th (ft)	149	86	54	114	0	#243	202	0	40	193	105
Internal Link Dist (ft)		1709		528			668			695	
Turn Bay Length (ft)	375		140		50	200		98	130		93
Base Capacity (vph)	767	808	796	994	907	352	1152	989	138	927	861
Starvation Cap Reductn	0	0	0	0	0	0	0	0	0	0	0
Spillback Cap Reductn	0	0	0	0	0	0	0	0	0	0	0
Storage Cap Reductn	0	0	0	0	0	0	0	0	0	0	0
Reduced v/c Ratio	0.23	0.12	0.28	0.13	0.02	0.61	0.25	0.03	0.18	0.26	0.31

Intersection Summary

# 95th percentile volume exceeds capacity, queue may be longer.  
Queue shown is maximum after two cycles.

Queues

2028 Opening Year No Project Conditions

2: Shiloh Road & Hembree Ln

Timing Plan: Saturday Midday Peak

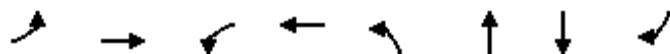

Lane Group	EBL	EBT	WBL	WBT	NBL	NBT	SBT	SBR
Lane Group Flow (vph)	753	426	24	484	65	26	211	732
v/c Ratio	0.77	0.41	0.15	0.53	0.40	0.15	0.71	0.74
Control Delay	30.8	9.8	34.2	13.8	40.4	23.8	44.5	11.6
Queue Delay	0.0	0.0	0.0	0.0	0.0	0.0	0.0	0.0
Total Delay	30.8	9.8	34.2	13.8	40.4	23.8	44.5	11.6
Queue Length 50th (ft)	124	80	8	49	22	4	72	29
Queue Length 95th (ft)	#362	179	37	82	#92	31	#263	#448
Internal Link Dist (ft)		222		1709		136	301	
Turn Bay Length (ft)			100					
Base Capacity (vph)	975	1571	162	2355	162	169	297	985
Starvation Cap Reductn	0	0	0	0	0	0	0	0
Spillback Cap Reductn	0	0	0	0	0	0	0	0
Storage Cap Reductn	0	0	0	0	0	0	0	0
Reduced v/c Ratio	0.77	0.27	0.15	0.21	0.40	0.15	0.71	0.74

Intersection Summary

# 95th percentile volume exceeds capacity, queue may be longer.  
 Queue shown is maximum after two cycles.

Queues  
3: US 101 NB Off-Ramp & Shiloh Road

2028 Opening Year No Project Conditions  
Timing Plan: Saturday Midday Peak

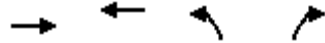

Lane Group	EBT	WBT	NBL	NBR
Lane Group Flow (vph)	486	869	422	693
v/c Ratio	0.26	0.89	0.72	0.56
Control Delay	10.0	30.3	25.4	6.7
Queue Delay	0.0	0.0	0.0	0.0
Total Delay	10.0	30.3	25.4	6.7
Queue Length 50th (ft)	50	274	136	33
Queue Length 95th (ft)	100	#622	221	71
Internal Link Dist (ft)	106	291	689	
Turn Bay Length (ft)				265
Base Capacity (vph)	1849	973	868	1608
Starvation Cap Reductn	0	0	0	0
Spillback Cap Reductn	0	0	0	0
Storage Cap Reductn	0	0	0	0
Reduced v/c Ratio	0.26	0.89	0.49	0.43

Intersection Summary

# 95th percentile volume exceeds capacity, queue may be longer.  
Queue shown is maximum after two cycles.

Queues

2028 Opening Year No Project Conditions

4: Shiloh Road & US 101 SB Off-Ramp

Timing Plan: Saturday Midday Peak

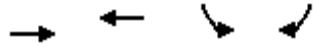

Lane Group	EBT	WBT	SBL	SBR
Lane Group Flow (vph)	331	625	312	256
v/c Ratio	0.39	0.74	0.51	0.36
Control Delay	9.6	16.1	17.1	4.1
Queue Delay	0.0	0.0	0.0	0.0
Total Delay	9.6	16.1	17.1	4.1
Queue Length 50th (ft)	53	124	62	0
Queue Length 95th (ft)	97	217	107	15
Internal Link Dist (ft)	145	226	406	
Turn Bay Length (ft)				275
Base Capacity (vph)	1863	1863	653	745
Starvation Cap Reductn	0	0	0	0
Spillback Cap Reductn	0	0	0	0
Storage Cap Reductn	0	0	0	0
Reduced v/c Ratio	0.18	0.34	0.48	0.34

Intersection Summary



Queues  
6: Conde Lane & Shiloh Road

2028 Opening Year No Project Conditions  
Timing Plan: Saturday Midday Peak

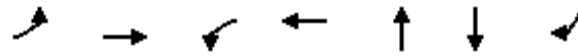

Lane Group	EBL	EBT	WBL	WBT	NBT	SBT	SBR
Lane Group Flow (vph)	34	420	11	747	14	287	41
v/c Ratio	0.09	0.28	0.03	0.57	0.03	0.59	0.07
Control Delay	23.3	9.9	23.9	12.8	0.1	27.9	12.2
Queue Delay	0.0	0.0	0.0	0.0	0.0	0.0	0.0
Total Delay	23.3	9.9	23.9	12.8	0.1	27.9	12.2
Queue Length 50th (ft)	5	24	2	41	0	46	4
Queue Length 95th (ft)	40	105	19	179	0	#240	27
Internal Link Dist (ft)		735		1001	338	442	
Turn Bay Length (ft)	90		127				40
Base Capacity (vph)	377	3099	355	2920	1326	488	1381
Starvation Cap Reductn	0	0	0	0	0	0	0
Spillback Cap Reductn	0	0	0	0	0	0	0
Storage Cap Reductn	0	0	0	0	0	0	0
Reduced v/c Ratio	0.09	0.14	0.03	0.26	0.01	0.59	0.03

Intersection Summary

# 95th percentile volume exceeds capacity, queue may be longer.  
Queue shown is maximum after two cycles.

Queues

2028 Opening Year No Project Conditions

10: US 101 NB Off Ramp/Lakewood Drive & Old Redwood Highway Timing Plan: Saturday Midday Peak



Lane Group	EBL	EBT	WBT	NBL	NBT	SBL	SBR
Lane Group Flow (vph)	302	329	874	262	519	277	795
v/c Ratio	0.96	0.35	0.70	0.66	0.61	0.94	0.99
Control Delay	81.7	15.1	23.9	35.6	26.8	80.3	45.6
Queue Delay	0.0	0.0	0.0	0.0	0.0	0.0	0.0
Total Delay	81.7	15.1	23.9	35.6	26.8	80.3	45.6
Queue Length 50th (ft)	81	98	173	131	113	74	277
Queue Length 95th (ft)	#180	188	273	215	163	#162	#521
Internal Link Dist (ft)		146	537		636		
Turn Bay Length (ft)	155			270		120	
Base Capacity (vph)	315	932	1255	576	1191	294	804
Starvation Cap Reductn	0	0	0	0	0	0	0
Spillback Cap Reductn	0	0	0	0	0	0	0
Storage Cap Reductn	0	0	0	0	0	0	0
Reduced v/c Ratio	0.96	0.35	0.70	0.45	0.44	0.94	0.99

Intersection Summary

# 95th percentile volume exceeds capacity, queue may be longer.  
 Queue shown is maximum after two cycles.

Queues

2028 Opening Year No Project Conditions

12: US 101 SB On Ramp/US 101 SB Off Ramp & Old Redwood Highway Timing Plan: Saturday Midday Peak



Lane Group	EBT	EBR	WBL	WBT	SBL	SBT
Lane Group Flow (vph)	567	432	507	852	174	158
v/c Ratio	0.40	0.49	1.09	0.33	0.72	0.48
Control Delay	16.2	3.8	94.8	3.9	47.2	14.6
Queue Delay	0.0	0.0	0.0	0.0	0.0	0.0
Total Delay	16.2	3.8	94.8	3.9	47.2	14.6
Queue Length 50th (ft)	89	0	~251	54	76	14
Queue Length 95th (ft)	128	50	#424	74	109	42
Internal Link Dist (ft)	343			451		751
Turn Bay Length (ft)			250		420	
Base Capacity (vph)	1406	877	467	2569	244	329
Starvation Cap Reductn	0	0	0	0	0	0
Spillback Cap Reductn	0	0	0	0	0	0
Storage Cap Reductn	0	0	0	0	0	0
Reduced v/c Ratio	0.40	0.49	1.09	0.33	0.71	0.48

Intersection Summary

~ Volume exceeds capacity, queue is theoretically infinite.























Queue shown is maximum after two cycles.

# 95th percentile volume exceeds capacity, queue may be longer.

Queue shown is maximum after two cycles.

Lanes, Volumes, Timings  
1: Old Redwood Hwy & Shiloh Road

2028 Opening Year No Project Conditions  
Timing Plan: A.M. PEAK

												
Lane Group	EBL	EBT	EBR	WBL	WBT	WBR	NBL	NBT	NBR	SBL	SBT	SBR
Lane Configurations												
Traffic Volume (vph)	137	120	96	25	61	13	93	142	39	15	263	208
Future Volume (vph)	137	120	96	25	61	13	93	142	39	15	263	208
Ideal Flow (vphpl)	1900	1900	1900	1900	1900	1900	1900	1900	1900	1900	1900	1900
Storage Length (ft)	375		140	0		50	200		98	130		93
Storage Lanes	1		1	0		1	1		1	1		1
Taper Length (ft)	50			25			60			93		
Lane Util. Factor	1.00	1.00	1.00	1.00	1.00	1.00	1.00	1.00	1.00	1.00	1.00	1.00
Ped Bike Factor												0.98
Frt			0.850			0.850			0.850			0.850
Flt Protected	0.950				0.986		0.950			0.950		
Satd. Flow (prot)	1770	1863	1583	0	1837	1583	1770	1863	1583	1770	1863	1583
Flt Permitted	0.950				0.986		0.950			0.950		
Satd. Flow (perm)	1770	1863	1583	0	1837	1583	1770	1863	1583	1770	1863	1549
Right Turn on Red			Yes			Yes			Yes			Yes
Satd. Flow (RTOR)			119			105			77			135
Link Speed (mph)		40			40			45			40	
Link Distance (ft)		1789			608			748			775	
Travel Time (s)		30.5			10.4			11.3			13.2	
Confl. Bikes (#/hr)												1
Peak Hour Factor	0.81	0.81	0.81	0.89	0.89	0.89	0.93	0.93	0.93	0.85	0.85	0.85
Adj. Flow (vph)	169	148	119	28	69	15	100	153	42	18	309	245
Shared Lane Traffic (%)												
Lane Group Flow (vph)	169	148	119	0	97	15	100	153	42	18	309	245
Enter Blocked Intersection	No	No	No	No	No	No	No	No	No	No	No	No
Lane Alignment	Left	Left	Right	Left	Left	Right	Left	Left	Right	Left	Left	Right
Median Width(ft)		12			12			12			12	
Link Offset(ft)		0			0			0			0	
Crosswalk Width(ft)		16			16			16			16	
Two way Left Turn Lane												
Headway Factor	1.00	1.00	1.00	1.00	1.00	1.00	1.00	1.00	1.00	1.00	1.00	1.00
Turning Speed (mph)	15		9	15		9	15		9	15		9
Number of Detectors	1	2	1	1	2	1	1	2	1	1	2	1
Detector Template	Left	Thru	Right	Left	Thru	Right	Left	Thru	Right	Left	Thru	Right
Leading Detector (ft)	20	100	20	20	100	20	20	100	20	20	100	20
Trailing Detector (ft)	0	0	0	0	0	0	0	0	0	0	0	0
Detector 1 Position(ft)	0	0	0	0	0	0	0	0	0	0	0	0
Detector 1 Size(ft)	20	6	20	20	6	20	20	6	20	20	6	20
Detector 1 Type	Cl+Ex	Cl+Ex	Cl+Ex	Cl+Ex	Cl+Ex	Cl+Ex	Cl+Ex	Cl+Ex	Cl+Ex	Cl+Ex	Cl+Ex	Cl+Ex
Detector 1 Channel												
Detector 1 Extend (s)	0.0	0.0	0.0	0.0	0.0	0.0	0.0	0.0	0.0	0.0	0.0	0.0
Detector 1 Queue (s)	0.0	0.0	0.0	0.0	0.0	0.0	0.0	0.0	0.0	0.0	0.0	0.0
Detector 1 Delay (s)	0.0	0.0	0.0	0.0	0.0	0.0	0.0	0.0	0.0	0.0	0.0	0.0
Detector 2 Position(ft)		94			94			94			94	
Detector 2 Size(ft)		6			6			6			6	
Detector 2 Type		Cl+Ex			Cl+Ex			Cl+Ex			Cl+Ex	
Detector 2 Channel												
Detector 2 Extend (s)		0.0			0.0			0.0			0.0	
Turn Type	Split	NA	Perm	Split	NA	Perm	Prot	NA	Perm	Prot	NA	Perm

Lanes, Volumes, Timings  
1: Old Redwood Hwy & Shiloh Road

2028 Opening Year No Project Conditions

Timing Plan: A.M. PEAK

Lane Group	EBL	EBT	EBR	WBL	WBT	WBR	NBL	NBT	NBR	SBL	SBT	SBR
Protected Phases	2	2		6	6		3	8		7	4	
Permitted Phases			2			6			8			4
Detector Phase	2	2	2	6	6	6	3	8	8	7	4	4
Switch Phase												
Minimum Initial (s)	5.0	5.0	5.0	5.0	5.0	5.0	5.0	5.0	5.0	5.0	5.0	5.0
Minimum Split (s)	34.5	34.5	34.5	42.5	42.5	42.5	8.5	46.5	46.5	8.5	39.5	39.5
Total Split (s)	35.0	35.0	35.0	42.5	42.5	42.5	18.0	48.0	48.0	9.5	39.5	39.5
Total Split (%)	25.9%	25.9%	25.9%	31.5%	31.5%	31.5%	13.3%	35.6%	35.6%	7.0%	29.3%	29.3%
Maximum Green (s)	30.5	30.5	30.5	38.0	38.0	38.0	14.5	43.5	43.5	6.0	35.0	35.0
Yellow Time (s)	3.5	3.5	3.5	3.5	3.5	3.5	3.0	3.5	3.5	3.0	3.5	3.5
All-Red Time (s)	1.0	1.0	1.0	1.0	1.0	1.0	0.5	1.0	1.0	0.5	1.0	1.0
Lost Time Adjust (s)	0.0	0.0	0.0		0.0	0.0	0.0	0.0	0.0	0.0	0.0	0.0
Total Lost Time (s)	4.5	4.5	4.5		4.5	4.5	3.5	4.5	4.5	3.5	4.5	4.5
Lead/Lag	Lead	Lead	Lead	Lag	Lag	Lag	Lead	Lag	Lag	Lead	Lag	Lag
Lead-Lag Optimize?	Yes	Yes	Yes	Yes	Yes	Yes	Yes	Yes	Yes	Yes	Yes	Yes
Vehicle Extension (s)	3.0	3.0	3.0	3.0	3.0	3.0	3.0	3.0	3.0	3.0	3.0	3.0
Recall Mode	None	None	None	None	None	None	None	None	None	None	None	None
Walk Time (s)	7.0	7.0	7.0	7.0	7.0	7.0		7.0	7.0		7.0	7.0
Flash Don't Walk (s)	23.0	23.0	23.0	31.0	31.0	31.0		35.0	35.0		28.0	28.0
Pedestrian Calls (#/hr)	0	0	0	0	0	0		0	0		0	0
Act Effct Green (s)	14.2	14.2	14.2		10.7	10.7	10.9	27.0	27.0	6.9	19.6	19.6
Actuated g/C Ratio	0.22	0.22	0.22		0.16	0.16	0.17	0.41	0.41	0.10	0.30	0.30
v/c Ratio	0.44	0.37	0.27		0.33	0.04	0.34	0.20	0.06	0.10	0.56	0.44
Control Delay (s/veh)	32.1	30.7	8.2		34.6	0.2	34.8	16.6	1.5	38.9	27.8	14.0
Queue Delay	0.0	0.0	0.0		0.0	0.0	0.0	0.0	0.0	0.0	0.0	0.0
Total Delay (s/veh)	32.1	30.7	8.2		34.6	0.2	34.8	16.6	1.5	38.9	27.8	14.0
LOS	C	C	A		C	A	C	B	A	D	C	B
Approach Delay (s/veh)		25.1			30.0			20.6			22.3	
Approach LOS		C			C			C			C	

Intersection Summary





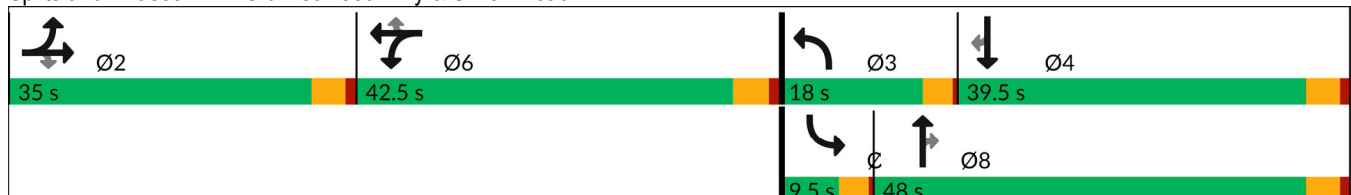















Area Type:	Other
Cycle Length:	135
Actuated Cycle Length:	65.8
Natural Cycle:	135
Control Type:	Actuated-Uncoordinated
Maximum v/c Ratio:	0.56
Intersection Signal Delay (s/veh):	23.4
Intersection LOS:	C
Intersection Capacity Utilization:	44.1%
ICU Level of Service:	A
Analysis Period (min):	15

Splits and Phases: 1: Old Redwood Hwy & Shiloh Road



Lanes, Volumes, Timings  
2: Shiloh Road & Hembree Ln

2028 Opening Year No Project Conditions  
Timing Plan: A.M. PEAK

												
Lane Group	EBL	EBT	EBR	WBL	WBT	WBR	NBL	NBT	NBR	SBL	SBT	SBR
Lane Configurations												
Traffic Volume (vph)	347	302	38	19	320	82	39	7	11	81	9	413
Future Volume (vph)	347	302	38	19	320	82	39	7	11	81	9	413
Ideal Flow (vphpl)	1900	1900	1900	1900	1900	1900	1900	1900	1900	1900	1900	1900
Storage Length (ft)	0		0	100		130	0		0	0		0
Storage Lanes	2		0	1		1	1		0	0		1
Taper Length (ft)	25			50			25			25		
Lane Util. Factor	0.97	1.00	1.00	1.00	0.95	0.95	1.00	1.00	1.00	1.00	1.00	1.00
Frt		0.985			0.969			0.908				0.850
Flt Protected	0.950			0.950			0.950				0.957	
Satd. Flow (prot)	3433	1835	0	1770	3430	0	1770	1691	0	0	1783	1583
Flt Permitted	0.950			0.950			0.950				0.957	
Satd. Flow (perm)	3433	1835	0	1770	3430	0	1770	1691	0	0	1783	1583
Right Turn on Red			Yes			Yes			Yes			Yes
Satd. Flow (RTOR)		11			47			11				439
Link Speed (mph)		40			40			30				35
Link Distance (ft)		302			1789			216				381
Travel Time (s)		5.1			30.5			4.9				7.4
Peak Hour Factor	0.88	0.88	1.00	1.00	0.97	0.97	1.00	1.00	1.00	0.94	1.00	0.94
Adj. Flow (vph)	394	343	38	19	330	85	39	7	11	86	9	439
Shared Lane Traffic (%)												
Lane Group Flow (vph)	394	381	0	19	415	0	39	18	0	0	95	439
Enter Blocked Intersection	No	No	No	No	No	No	No	No	No	No	No	No
Lane Alignment	Left	Left	Right	Left	Left	Right	Left	Left	Right	Left	Left	Right
Median Width(ft)		24			24			12				12
Link Offset(ft)		0			0			0				0
Crosswalk Width(ft)		16			16			16				16
Two way Left Turn Lane												
Headway Factor	1.00	1.00	1.00	1.00	1.00	1.00	1.00	1.00	1.00	1.00	1.00	1.00
Turning Speed (mph)	15		60	60		9	60		60	15		9
Number of Detectors	1	2		1	2		1	2		1	2	1
Detector Template	Left	Thru		Left	Thru		Left	Thru		Left	Thru	Right
Leading Detector (ft)	20	100		20	100		20	100		20	100	20
Trailing Detector (ft)	0	0		0	0		0	0		0	0	0
Detector 1 Position(ft)	0	0		0	0		0	0		0	0	0
Detector 1 Size(ft)	20	6		20	6		20	6		20	6	20
Detector 1 Type	Cl+Ex	Cl+Ex		Cl+Ex	Cl+Ex		Cl+Ex	Cl+Ex		Cl+Ex	Cl+Ex	Cl+Ex
Detector 1 Channel												
Detector 1 Extend (s)	0.0	0.0		0.0	0.0		0.0	0.0		0.0	0.0	0.0
Detector 1 Queue (s)	0.0	0.0		0.0	0.0		0.0	0.0		0.0	0.0	0.0
Detector 1 Delay (s)	0.0	0.0		0.0	0.0		0.0	0.0		0.0	0.0	0.0
Detector 2 Position(ft)		94			94			94				94
Detector 2 Size(ft)		6			6			6				6
Detector 2 Type		Cl+Ex			Cl+Ex			Cl+Ex				Cl+Ex
Detector 2 Channel												
Detector 2 Extend (s)		0.0			0.0			0.0				0.0
Turn Type	Prot	NA		Prot	NA		Split	NA		Split	NA	pt+ov
Protected Phases	5	2		1	6		8	8		4	4	4 5
Permitted Phases												

Lanes, Volumes, Timings  
2: Shiloh Road & Hembree Ln

2028 Opening Year No Project Conditions  
Timing Plan: A.M. PEAK

Lane Group	EBL	EBT	EBR	WBL	WBT	WBR	NBL	NBT	NBR	SBL	SBT	SBR
Detector Phase	5	2		1	6		8	8		4	4	4 5
Switch Phase												
Minimum Initial (s)	3.0	5.0		5.0	5.0		5.0	5.0		5.0	5.0	
Minimum Split (s)	7.5	9.5		9.5	43.5		9.5	9.5		9.5	9.5	
Total Split (s)	21.0	57.0		9.5	45.5		9.5	9.5		14.0	14.0	
Total Split (%)	23.3%	63.3%		10.6%	50.6%		10.6%	10.6%		15.6%	15.6%	
Maximum Green (s)	17.0	53.0		5.5	41.5		5.5	5.5		10.0	10.0	
Yellow Time (s)	3.0	3.0		3.0	3.0		3.0	3.0		3.0	3.0	
All-Red Time (s)	1.0	1.0		1.0	1.0		1.0	1.0		1.0	1.0	
Lost Time Adjust (s)	0.0	0.0		0.0	0.0		0.0	0.0		0.0	0.0	
Total Lost Time (s)	4.0	4.0		4.0	4.0		4.0	4.0		4.0	4.0	
Lead/Lag	Lead	Lag		Lead	Lag							
Lead-Lag Optimize?	Yes	Yes		Yes	Yes							
Vehicle Extension (s)	3.0	3.0		3.0	3.0		3.0	3.0		3.0	3.0	
Recall Mode	None	None		None	None		None	None		None	None	
Walk Time (s)					7.0							
Flash Don't Walk (s)					32.0							
Pedestrian Calls (#/hr)					1							
Act Effct Green (s)	12.2	30.2		6.2	14.6		6.2	6.2		8.9	23.6	
Actuated g/C Ratio	0.23	0.56		0.11	0.27		0.11	0.11		0.16	0.44	
v/c Ratio	0.51	0.37		0.09	0.43		0.19	0.09		0.33	0.47	
Control Delay (s/veh)	24.0	8.8		32.5	16.1		33.0	23.4		29.6	3.2	
Queue Delay	0.0	0.0		0.0	0.0		0.0	0.0		0.0	0.0	
Total Delay (s/veh)	24.0	8.8		32.5	16.1		33.0	23.4		29.6	3.2	
LOS	C	A		C	B		C	C		C	A	
Approach Delay (s/veh)		16.5			16.8			30.0			7.9	
Approach LOS		B			B			C			A	

Intersection Summary	
Area Type:	Other
Cycle Length:	90
Actuated Cycle Length:	54.1
Natural Cycle:	80
Control Type:	Actuated-Uncoordinated
Maximum v/c Ratio:	0.51
Intersection Signal Delay (s/veh):	14.5
Intersection LOS:	B
Intersection Capacity Utilization:	51.2%
ICU Level of Service:	A
Analysis Period (min):	15

Splits and Phases: 2: Shiloh Road & Hembree Ln



Lanes, Volumes, Timings  
 3: US 101 NB Off-Ramp & Shiloh Road

2028 Opening Year No Project Conditions  
 Timing Plan: A.M. PEAK

	→	↘	↙	←	↖	↗
Lane Group	EBT	EBR	WBL	WBT	NBL	NBR
Lane Configurations	↑↑			↑	↘	↗↗
Traffic Volume (vph)	276	0	0	614	492	427
Future Volume (vph)	276	0	0	614	492	427
Ideal Flow (vphpl)	1900	1900	1900	1900	1900	1900
Storage Length (ft)		0	0		0	265
Storage Lanes		0	0		1	2
Taper Length (ft)			25		25	
Lane Util. Factor	0.95	1.00	1.00	1.00	1.00	0.88
Frt						0.850
Flt Protected					0.950	
Satd. Flow (prot)	3539	0	0	1863	1770	2787
Flt Permitted					0.950	
Satd. Flow (perm)	3539	0	0	1863	1770	2787
Right Turn on Red		Yes				Yes
Satd. Flow (RTOR)						562
Link Speed (mph)	40			40	30	
Link Distance (ft)	186			371	769	
Travel Time (s)	3.2			6.3	17.5	
Peak Hour Factor	0.91	0.91	0.90	0.90	0.76	0.76
Adj. Flow (vph)	303	0	0	682	647	562
Shared Lane Traffic (%)						
Lane Group Flow (vph)	303	0	0	682	647	562
Enter Blocked Intersection	No	No	No	No	No	No
Lane Alignment	Left	Right	Left	Left	Left	Right
Median Width(ft)	0			0	12	
Link Offset(ft)	0			0	0	
Crosswalk Width(ft)	16			16	16	
Two way Left Turn Lane						
Headway Factor	1.00	1.00	1.00	1.00	1.00	1.00
Turning Speed (mph)		9	15		15	9
Number of Detectors	2			2	1	1
Detector Template	Thru			Thru	Left	Right
Leading Detector (ft)	100			100	20	20
Trailing Detector (ft)	0			0	0	0
Detector 1 Position(ft)	0			0	0	0
Detector 1 Size(ft)	6			6	20	20
Detector 1 Type	Cl+Ex			Cl+Ex	Cl+Ex	Cl+Ex
Detector 1 Channel						
Detector 1 Extend (s)	0.0			0.0	0.0	0.0
Detector 1 Queue (s)	0.0			0.0	0.0	0.0
Detector 1 Delay (s)	0.0			0.0	0.0	0.0
Detector 2 Position(ft)	94			94		
Detector 2 Size(ft)	6			6		
Detector 2 Type	Cl+Ex			Cl+Ex		
Detector 2 Channel						
Detector 2 Extend (s)	0.0			0.0		
Turn Type	NA			NA	Prot	Perm
Protected Phases	2			6	8	
Permitted Phases						8



Lanes, Volumes, Timings  
 3: US 101 NB Off-Ramp & Shiloh Road

2028 Opening Year No Project Conditions  
 Timing Plan: A.M. PEAK

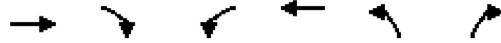

Lane Group	EBT	EBR	WBL	WBT	NBL	NBR
Detector Phase	2			6	8	8
Switch Phase						
Minimum Initial (s)	5.0			5.0	5.0	5.0
Minimum Split (s)	9.0			9.0	9.0	9.0
Total Split (s)	37.0			37.0	35.0	35.0
Total Split (%)	51.4%			51.4%	48.6%	48.6%
Maximum Green (s)	33.0			33.0	31.0	31.0
Yellow Time (s)	3.0			3.0	3.0	3.0
All-Red Time (s)	1.0			1.0	1.0	1.0
Lost Time Adjust (s)	0.0			0.0	0.0	0.0
Total Lost Time (s)	4.0			4.0	4.0	4.0
Lead/Lag						
Lead-Lag Optimize?						
Vehicle Extension (s)	3.0			3.0	3.0	3.0
Recall Mode	None			None	None	None
Act Effect Green (s)	27.5			27.5	27.2	27.2
Actuated g/C Ratio	0.44			0.44	0.43	0.43
v/c Ratio	0.20			0.84	0.85	0.37
Control Delay (s/veh)	11.7			27.6	30.0	2.1
Queue Delay	0.0			0.0	0.0	0.0
Total Delay (s/veh)	11.7			27.6	30.0	2.1
LOS	B			C	C	A
Approach Delay (s/veh)	11.7			27.6	17.1	
Approach LOS	B			C	B	

Intersection Summary

Area Type: Other  
 Cycle Length: 72  
 Actuated Cycle Length: 63.1  
 Natural Cycle: 60  
 Control Type: Actuated-Uncoordinated  
 Maximum v/c Ratio: 0.85  
 Intersection Signal Delay (s/veh): 19.6  
 Intersection LOS: B  
 Intersection Capacity Utilization 90.3%  
 ICU Level of Service E  
 Analysis Period (min) 15

Splits and Phases: 3: US 101 NB Off-Ramp & Shiloh Road

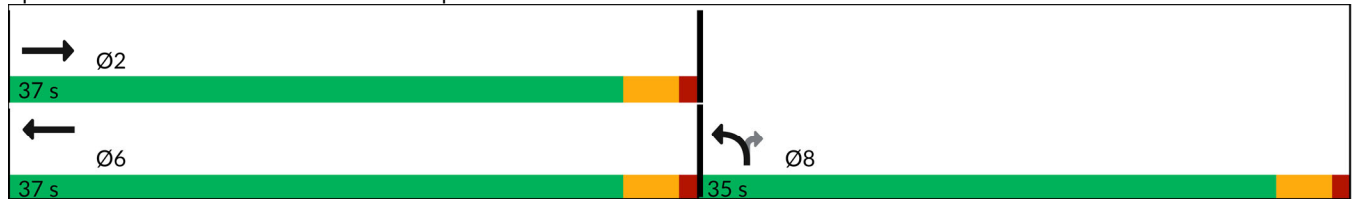

Lanes, Volumes, Timings  
4: Shiloh Road & US 101 SB Off-Ramp

2028 Opening Year No Project Conditions

Timing Plan: A.M. PEAK

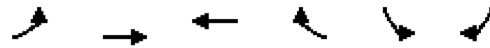

Lane Group	EBL	EBT	WBT	WBR	SBL	SBR
Lane Configurations		↑	↑		↘	↗
Traffic Volume (vph)	0	267	676	0	92	174
Future Volume (vph)	0	267	676	0	92	174
Ideal Flow (vphpl)	1900	1900	1900	1900	1900	1900
Storage Length (ft)	0			0	0	275
Storage Lanes	0			0	1	1
Taper Length (ft)	25				25	
Lane Util. Factor	1.00	1.00	1.00	1.00	1.00	1.00
Frt						0.850
Flt Protected					0.950	
Satd. Flow (prot)	0	1863	1863	0	1770	1583
Flt Permitted					0.950	
Satd. Flow (perm)	0	1863	1863	0	1770	1583
Right Turn on Red				Yes		Yes
Satd. Flow (RTOR)						189
Link Speed (mph)		40	40		30	
Link Distance (ft)		225	306		486	
Travel Time (s)		3.8	5.2		11.0	
Peak Hour Factor	0.93	0.93	0.91	0.91	0.92	0.92
Adj. Flow (vph)	0	287	743	0	100	189
Shared Lane Traffic (%)						
Lane Group Flow (vph)	0	287	743	0	100	189
Enter Blocked Intersection	No	No	No	No	No	No
Lane Alignment	Left	Left	Left	Right	Left	Right
Median Width(ft)		4	0		12	
Link Offset(ft)		0	0		0	
Crosswalk Width(ft)		16	16		16	
Two way Left Turn Lane						
Headway Factor	1.00	1.00	1.00	1.00	1.00	1.00
Turning Speed (mph)	15			9	15	9
Number of Detectors		2	2		1	1
Detector Template		Thru	Thru		Left	Right
Leading Detector (ft)		100	100		20	20
Trailing Detector (ft)		0	0		0	0
Detector 1 Position(ft)		0	0		0	0
Detector 1 Size(ft)		6	6		20	20
Detector 1 Type		Cl+Ex	Cl+Ex		Cl+Ex	Cl+Ex
Detector 1 Channel						
Detector 1 Extend (s)		0.0	0.0		0.0	0.0
Detector 1 Queue (s)		0.0	0.0		0.0	0.0
Detector 1 Delay (s)		0.0	0.0		0.0	0.0
Detector 2 Position(ft)		94	94			
Detector 2 Size(ft)		6	6			
Detector 2 Type		Cl+Ex	Cl+Ex			
Detector 2 Channel						
Detector 2 Extend (s)		0.0	0.0			
Turn Type		NA	NA		Perm	Perm
Protected Phases		2	6			
Permitted Phases					4	4

Lanes, Volumes, Timings  
4: Shiloh Road & US 101 SB Off-Ramp

2028 Opening Year No Project Conditions  
Timing Plan: A.M. PEAK



Lane Group	EBL	EBT	WBT	WBR	SBL	SBR
Detector Phase		2	6		4	4
Switch Phase						
Minimum Initial (s)		5.0	5.0		5.0	5.0
Minimum Split (s)		9.0	38.0		9.0	9.0
Total Split (s)		69.0	69.0		21.0	21.0
Total Split (%)		76.7%	76.7%		23.3%	23.3%
Maximum Green (s)		65.0	65.0		17.0	17.0
Yellow Time (s)		3.0	3.0		3.0	3.0
All-Red Time (s)		1.0	1.0		1.0	1.0
Lost Time Adjust (s)		0.0	0.0		0.0	0.0
Total Lost Time (s)		4.0	4.0		4.0	4.0
Lead/Lag						
Lead-Lag Optimize?						
Vehicle Extension (s)		3.0	3.0		3.0	3.0
Recall Mode		None	None		None	None
Walk Time (s)			7.0			
Flash Don't Walk (s)			27.0			
Pedestrian Calls (#/hr)			0			
Act Effct Green (s)		24.2	24.2		8.6	8.6
Actuated g/C Ratio		0.67	0.67		0.24	0.24
v/c Ratio		0.23	0.59		0.24	0.36
Control Delay (s/veh)		4.3	7.6		16.8	5.9
Queue Delay		0.0	0.0		0.0	0.0
Total Delay (s/veh)		4.3	7.6		16.8	5.9
LOS		A	A		B	A
Approach Delay (s/veh)		4.3	7.6		9.7	
Approach LOS		A	A		A	

Intersection Summary

Area Type:	Other
Cycle Length:	90
Actuated Cycle Length:	36
Natural Cycle:	50
Control Type:	Actuated-Uncoordinated
Maximum v/c Ratio:	0.59
Intersection Signal Delay (s/veh):	7.4
Intersection LOS:	A
Intersection Capacity Utilization:	63.0%
ICU Level of Service:	B
Analysis Period (min):	15

Splits and Phases: 4: Shiloh Road & US 101 SB Off-Ramp

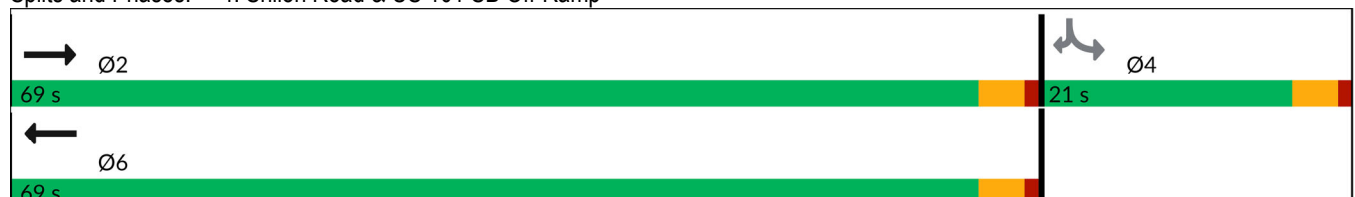

Lanes, Volumes, Timings  
5: Caletti Ave & Shiloh Road

2028 Opening Year No Project Conditions

Timing Plan: A.M. PEAK

	→	↘	↙	←	↖	↗
Lane Group	EBT	EBR	WBL	WBT	NBL	NBR
Lane Configurations	↑↑		↘	↑	↘	↗
Traffic Volume (vph)	590	25	202	623	8	138
Future Volume (vph)	590	25	202	623	8	138
Ideal Flow (vphpl)	1900	1900	1900	1900	1900	1900
Storage Length (ft)		0	68		0	0
Storage Lanes		0	1		1	1
Taper Length (ft)			50		25	
Lane Util. Factor	0.95	0.95	1.00	1.00	1.00	1.00
Frt	0.994					0.850
Flt Protected			0.950		0.950	
Satd. Flow (prot)	3518	0	1770	1863	1770	1583
Flt Permitted			0.950		0.950	
Satd. Flow (perm)	3518	0	1770	1863	1770	1583
Link Speed (mph)	40			40	30	
Link Distance (ft)	1081			184	459	
Travel Time (s)	18.4			3.1	10.4	
Peak Hour Factor	0.96	0.96	0.87	0.87	0.84	0.84
Adj. Flow (vph)	615	26	232	716	10	164
Shared Lane Traffic (%)						
Lane Group Flow (vph)	641	0	232	716	10	164
Enter Blocked Intersection	No	No	No	No	No	No
Lane Alignment	Left	Right	Left	Left	Left	Right
Median Width(ft)	12			12	12	
Link Offset(ft)	0			0	0	
Crosswalk Width(ft)	16			16	16	
Two way Left Turn Lane						
Headway Factor	1.00	1.00	1.00	1.00	1.00	1.00
Turning Speed (mph)		9	15		15	9
Sign Control	Free			Free	Stop	
<b>Intersection Summary</b>						
Area Type:	Other					
Control Type:	Unsignalized					
Intersection Capacity Utilization	42.8%			ICU Level of Service A		
Analysis Period (min)	15					

Lanes, Volumes, Timings  
6: Conde Lane & Shiloh Road

2028 Opening Year No Project Conditions  
Timing Plan: A.M. PEAK

Lane Group	EBL	EBT	EBR	WBL	WBT	WBR	NBL	NBT	NBR	SBL	SBT	SBR
Lane Configurations												
Traffic Volume (vph)	28	368	6	10	400	232	5	0	14	233	1	40
Future Volume (vph)	28	368	6	10	400	232	5	0	14	233	1	40
Ideal Flow (vphpl)	1900	1900	1900	1900	1900	1900	1900	1900	1900	1900	1900	1900
Storage Length (ft)	90		0	127		0	0		0	0		40
Storage Lanes	1		0	1		0	0		0	0		1
Taper Length (ft)	70			40			25			25		
Lane Util. Factor	1.00	0.95	0.95	1.00	0.95	0.95	1.00	1.00	1.00	1.00	1.00	1.00
Frt		0.998			0.945			0.901				0.850
Flt Protected	0.950			0.950				0.987			0.953	
Satd. Flow (prot)	1770	3532	0	1770	3345	0	0	1657	0	0	1775	1583
Flt Permitted	0.950			0.950				0.987			0.953	
Satd. Flow (perm)	1770	3532	0	1770	3345	0	0	1657	0	0	1775	1583
Right Turn on Red			Yes			Yes			Yes			No
Satd. Flow (RTOR)		2			120			89				
Link Speed (mph)		40			40			30				35
Link Distance (ft)		815			1081			418				522
Travel Time (s)		13.9			18.4			9.5				10.2
Peak Hour Factor	0.95	0.95	0.95	0.85	0.85	0.85	0.57	0.57	0.57	0.86	0.86	0.86
Adj. Flow (vph)	29	387	6	12	471	273	9	0	25	271	1	47
Shared Lane Traffic (%)												
Lane Group Flow (vph)	29	393	0	12	744	0	0	34	0	0	272	47
Enter Blocked Intersection	No	No	No	No	No	No	No	No	No	No	No	No
Lane Alignment	Left	Left	Right	Left	Left	Right	Left	Left	Right	Left	Left	Right
Median Width(ft)		12			12			0				0
Link Offset(ft)		0			0			0				0
Crosswalk Width(ft)		16			16			16				16
Two way Left Turn Lane												
Headway Factor	1.00	1.00	1.00	1.00	1.00	1.00	1.00	1.00	1.00	1.00	1.00	1.00
Turning Speed (mph)	15		9	15		9	15		9	15		9
Number of Detectors	1	2		1	2		1	2		1	1	1
Detector Template	Left	Thru		Left	Thru		Left	Thru		Left	Thru	Right
Leading Detector (ft)	20	100		20	100		20	100		20	30	20
Trailing Detector (ft)	0	0		0	0		0	0		0	0	0
Detector 1 Position(ft)	0	0		0	0		0	0		0	0	0
Detector 1 Size(ft)	20	6		20	6		20	6		20	30	20
Detector 1 Type	Cl+Ex	Cl+Ex		Cl+Ex	Cl+Ex		Cl+Ex	Cl+Ex		Cl+Ex	Cl+Ex	Cl+Ex
Detector 1 Channel												
Detector 1 Extend (s)	0.0	0.0		0.0	0.0		0.0	0.0		0.0	0.0	0.0
Detector 1 Queue (s)	0.0	0.0		0.0	0.0		0.0	0.0		0.0	0.0	0.0
Detector 1 Delay (s)	0.0	0.0		0.0	0.0		0.0	0.0		0.0	0.0	0.0
Detector 2 Position(ft)		94			94			94				
Detector 2 Size(ft)		6			6			6				
Detector 2 Type		Cl+Ex			Cl+Ex			Cl+Ex				
Detector 2 Channel												
Detector 2 Extend (s)		0.0			0.0			0.0				
Turn Type	Prot	NA		Prot	NA		Split	NA		Split	NA	custom
Protected Phases	5	2		1	6		7	7		4	4	
Permitted Phases												6

Lanes, Volumes, Timings  
6: Conde Lane & Shiloh Road

2028 Opening Year No Project Conditions  
Timing Plan: A.M. PEAK

Lane Group	EBL	EBT	EBR	WBL	WBT	WBR	NBL	NBT	NBR	SBL	SBT	SBR
Detector Phase	5	2		1	6		7	7		4	4	6
Switch Phase												
Minimum Initial (s)	8.0	8.0		8.0	8.0		10.0	10.0		11.0	11.0	8.0
Minimum Split (s)	12.0	46.0		12.0	12.0		37.0	37.0		15.0	15.0	12.0
Total Split (s)	13.0	46.0		12.0	45.0		37.0	37.0		15.0	15.0	45.0
Total Split (%)	11.8%	41.8%		10.9%	40.9%		33.6%	33.6%		13.6%	13.6%	40.9%
Maximum Green (s)	9.0	42.0		8.0	41.0		33.0	33.0		11.0	11.0	41.0
Yellow Time (s)	3.0	3.0		3.0	3.0		3.0	3.0		3.0	3.0	3.0
All-Red Time (s)	1.0	1.0		1.0	1.0		1.0	1.0		1.0	1.0	1.0
Lost Time Adjust (s)	0.0	0.0		0.0	0.0		0.0	0.0		0.0	0.0	0.0
Total Lost Time (s)	4.0	4.0		4.0	4.0		4.0	4.0		4.0	4.0	4.0
Lead/Lag	Lead	Lag		Lead	Lag							Lag
Lead-Lag Optimize?	Yes	Yes		Yes	Yes							Yes
Vehicle Extension (s)	3.0	3.0		3.0	3.0		3.0	3.0		3.0	3.0	3.0
Recall Mode	None	None		None	None		None	None		None	None	None
Walk Time (s)		7.0					7.0	7.0				
Flash Don't Walk (s)		35.0					26.0	26.0				
Pedestrian Calls (#/hr)		0					0	0				
Act Effct Green (s)	9.3	19.5		9.3	17.7			11.6			12.8	17.7
Actuated g/C Ratio	0.20	0.42		0.20	0.38			0.25			0.27	0.38
v/c Ratio	0.08	0.27		0.03	0.56			0.07			0.56	0.08
Control Delay (s/veh)	25.4	10.6		25.7	12.9			0.3			30.0	13.3
Queue Delay	0.0	0.0		0.0	0.0			0.0			0.0	0.0
Total Delay (s/veh)	25.4	10.6		25.7	12.9			0.3			30.0	13.3
LOS	C	B		C	B			A			C	B
Approach Delay (s/veh)		11.6			13.2			0.3			27.5	
Approach LOS		B			B			A			C	

Intersection Summary





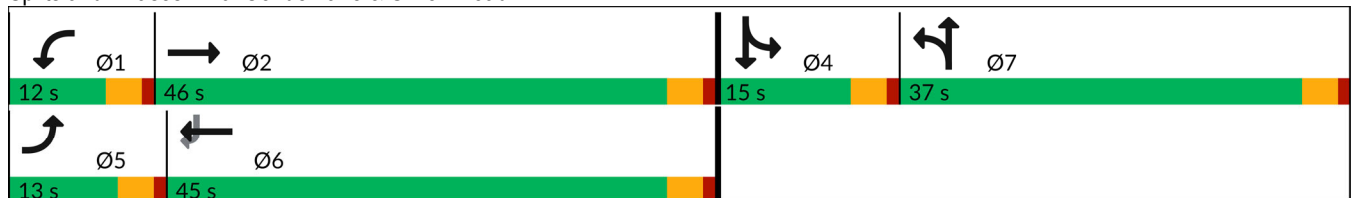











Area Type:	Other
Cycle Length:	110
Actuated Cycle Length:	46.9
Natural Cycle:	110
Control Type:	Actuated-Uncoordinated
Maximum v/c Ratio:	0.56
Intersection Signal Delay (s/veh):	15.4
Intersection LOS:	B
Intersection Capacity Utilization:	49.6%
ICU Level of Service:	A
Analysis Period (min):	15

Splits and Phases: 6: Conde Lane & Shiloh Road





















Lanes, Volumes, Timings  
7: Entrance 1/Gridley Drive & Shiloh Road

2028 Opening Year No Project Conditions  
Timing Plan: A.M. PEAK

													
Lane Group	EBL	EBT	EBR	WBL	WBT	WBR	NBL	NBT	NBR	SBL	SBT	SBR	
Lane Configurations													
Traffic Volume (vph)	9	161	0	0	66	0	0	0	0	1	0	18	
Future Volume (vph)	9	161	0	0	66	0	0	0	0	1	0	18	
Ideal Flow (vphpl)	1900	1900	1900	1900	1900	1900	1900	1900	1900	1900	1900	1900	
Lane Util. Factor	1.00	1.00	1.00	1.00	1.00	1.00	1.00	1.00	1.00	1.00	1.00	1.00	
Ped Bike Factor													
Frt												0.870	
Flt Protected	0.997											0.998	
Satd. Flow (prot)	0	1857	0	0	1863	0	1863	1863	0	0	1617	0	
Flt Permitted	0.997											0.998	
Satd. Flow (perm)	0	1857	0	0	1863	0	1863	1863	0	0	1617	0	
Link Speed (mph)					40					30			30
Link Distance (ft)					608					2146			248
Travel Time (s)					10.4					36.6			5.6
Confl. Bikes (#/hr)			1										
Peak Hour Factor	0.91	0.91	0.91	0.85	0.85	0.85	1.00	1.00	1.00	0.71	0.71	0.71	
Adj. Flow (vph)	10	177	0	0	78	0	0	0	0	1	0	25	
Shared Lane Traffic (%)													
Lane Group Flow (vph)	0	187	0	0	78	0	0	0	0	0	26	0	
Enter Blocked Intersection	No	No	No	No	No	No	No	No	No	No	No	No	
Lane Alignment	Left	Left	Right	Left	Left	Right	Left	Left	Right	Left	Left	Right	
Median Width(ft)	0				0				12		12		
Link Offset(ft)	0				0				0		0		
Crosswalk Width(ft)	16				16				16		16		
Two way Left Turn Lane													
Headway Factor	1.00	1.00	1.00	1.00	1.00	1.00	1.00	1.00	1.00	1.00	1.00	1.00	
Turning Speed (mph)	15		9		15		9		15		9		
Sign Control	Free				Free				Stop		Stop		
<b>Intersection Summary</b>													
Area Type:	Other												
Control Type:	Unsignalized												
Intersection Capacity Utilization	25.6%						ICU Level of Service A						
Analysis Period (min)	15												

Lanes, Volumes, Timings  
8: Old Redwood Hwy & Entrance 1

2028 Opening Year No Project Conditions  
Timing Plan: A.M. PEAK











												
Lane Group	EBL	EBT	EBR	WBL	WBT	WBR	NBL	NBT	NBR	SBL	SBT	SBR
Lane Configurations												
Traffic Volume (vph)	1	0	0	0	0	0	0	247	0	0	360	0
Future Volume (vph)	1	0	0	0	0	0	0	247	0	0	360	0
Ideal Flow (vphp)	1900	1900	1900	1900	1900	1900	1900	1900	1900	1900	1900	1900
Storage Length (ft)	0		0	0		0	0		0	50		0
Storage Lanes	0		0	1		0	0		0	1		0
Taper Length (ft)	25			25			25			25		
Lane Util. Factor	1.00	1.00	1.00	1.00	1.00	1.00	1.00	1.00	1.00	1.00	1.00	1.00
Ped Bike Factor												
Fr <sub>t</sub>												
Fl <sub>t</sub> Protected		0.950										
Satd. Flow (prot)	0	1770	0	1863	1863	0	0	1863	0	1863	1863	0
Fl <sub>t</sub> Permitted		0.950										
Satd. Flow (perm)	0	1770	0	1863	1863	0	0	1863	0	1863	1863	0
Link Speed (mph)		30			30			45			45	
Link Distance (ft)		98			385			520			748	
Travel Time (s)		2.2			8.8			7.9			11.3	
Confl. Peds. (#/hr)									1	1		
Confl. Bikes (#/hr)									1			2
Peak Hour Factor	0.25	0.25	0.25	1.00	1.00	1.00	0.99	0.99	0.99	0.90	0.90	0.90
Adj. Flow (vph)	4	0	0	0	0	0	0	249	0	0	400	0
Shared Lane Traffic (%)												
Lane Group Flow (vph)	0	4	0	0	0	0	0	249	0	0	400	0
Enter Blocked Intersection	No	No	No	No	No	No	No	No	No	No	No	No
Lane Alignment	Left	Left	Right	Left	Left	Right	Left	Left	Right	Left	Left	Right
Median Width(ft)		12			12			12			12	
Link Offset(ft)		0			0			0			0	
Crosswalk Width(ft)		16			16			16			16	
Two way Left Turn Lane												
Headway Factor	1.00	1.00	1.00	1.00	1.00	1.00	1.00	1.00	1.00	1.00	1.00	1.00
Turning Speed (mph)	15		9	15		9	15		9	15		9
Sign Control		Stop			Stop			Free			Free	
<b>Intersection Summary</b>												
Area Type:	Other											
Control Type:	Unsignalized											
Intersection Capacity Utilization	28.9%						ICU Level of Service A					
Analysis Period (min)	15											



Lanes, Volumes, Timings  
9: Entrance 2 & Shiloh Road

2028 Opening Year No Project Conditions

Timing Plan: A.M. PEAK

						
Lane Group	EBT	EBR	WBL	WBT	NBL	NBR
Lane Configurations						
Traffic Volume (vph)	159	0	0	59	0	0
Future Volume (vph)	159	0	0	59	0	0
Ideal Flow (vphp)	1900	1900	1900	1900	1900	1900
Lane Util. Factor	1.00	1.00	1.00	1.00	1.00	1.00
<b>Fr</b>						
<b>Flt Protected</b>						
Satd. Flow (prot)	1863	0	0	1863	1863	1863
<b>Flt Permitted</b>						
Satd. Flow (perm)	1863	0	0	1863	1863	1863
Link Speed (mph)	40			40	30	
Link Distance (ft)	2146			134	402	
Travel Time (s)	36.6			2.3	9.1	
Peak Hour Factor	0.85	0.85	0.81	0.81	1.00	1.00
Adj. Flow (vph)	187	0	0	73	0	0
<b>Shared Lane Traffic (%)</b>						
Lane Group Flow (vph)	187	0	0	73	0	0
Enter Blocked Intersection	No	No	No	No	No	No
Lane Alignment	Left	Right	Left	Left	Left	Right
Median Width(ft)	0			0	12	
Link Offset(ft)	0			0	0	
Crosswalk Width(ft)	16			16	16	
<b>Two way Left Turn Lane</b>						
Headway Factor	1.00	1.00	1.00	1.00	1.00	1.00
Turning Speed (mph)		9	15		15	9
Sign Control	Free			Free	Stop	
<b>Intersection Summary</b>						
Area Type:	Other					
Control Type:	Unsignalized					
Intersection Capacity Utilization	11.7%			ICU Level of Service A		
Analysis Period (min)	15					

Lanes, Volumes, Timings

2028 Opening Year No Project Conditions

10: US 101 NB Off Ramp/Lakewood Drive & Old Redwood Highway

Timing Plan: A.M. PEAK



Lane Group	EBL	EBT	EBR	WBL	WBT	WBR	NBL	NBT	NBR	SBL	SBT	SBR
Lane Configurations												
Traffic Volume (vph)	173	170	0	0	501	170	258	252	90	134	0	608
Future Volume (vph)	173	170	0	0	501	170	258	252	90	134	0	608
Ideal Flow (vphpl)	1900	1900	1900	1900	1900	1900	1900	1900	1900	1900	1900	1900
Storage Length (ft)	155		0	0		0	270		150	120		0
Storage Lanes	1		0	0		0	1		1	1		1
Taper Length (ft)	50			25			165			75		
Lane Util. Factor	0.97	1.00	1.00	1.00	0.95	0.95	0.91	0.91	0.95	0.97	1.00	1.00
Ped Bike Factor	1.00				1.00			1.00		1.00		
Flt					0.962			0.966				0.850
Flt Protected	0.950						0.950	0.993		0.950		
Satd. Flow (prot)	3433	1863	0	0	3393	0	1610	3242	0	3433	0	1583
Flt Permitted	0.950						0.950	0.993		0.950		
Satd. Flow (perm)	3431	1863	0	0	3393	0	1610	3242	0	3427	0	1583
Right Turn on Red			Yes			Yes			Yes			Yes
Satd. Flow (RTOR)					53			41				283
Link Speed (mph)		35			35			30				30
Link Distance (ft)		226			617			716				478
Travel Time (s)		4.4			12.0			16.3				10.9
Confl. Peds. (#/hr)	1		1	1		1			2	2		
Confl. Bikes (#/hr)			1			1						
Peak Hour Factor	0.85	0.85	0.85	0.83	0.83	0.83	0.90	0.90	0.90	0.89	0.89	0.89
Adj. Flow (vph)	204	200	0	0	604	205	287	280	100	151	0	683
Shared Lane Traffic (%)							23%					
Lane Group Flow (vph)	204	200	0	0	809	0	221	446	0	151	0	683
Enter Blocked Intersection	No	No	No	No	No	No	No	No	No	No	No	No
Lane Alignment	Left	Left	Right	Left	Left	Right	Left	Left	Right	Left	Left	Right
Median Width(ft)		24			24			24				24
Link Offset(ft)		0			0			0				0
Crosswalk Width(ft)		16			16			16				16
Two way Left Turn Lane												
Headway Factor	1.00	1.00	1.00	1.00	1.00	1.00	1.00	1.00	1.00	1.00	1.00	1.00
Turning Speed (mph)	15		9	15		9	15		9	15		9
Number of Detectors	1	2			2		1	2		1		1
Detector Template	Left	Thru			Thru		Left	Thru		Left		Right
Leading Detector (ft)	20	100			100		20	100		20		20
Trailing Detector (ft)	0	0			0		0	0		0		0
Detector 1 Position(ft)	0	0			0		0	0		0		0
Detector 1 Size(ft)	20	6			6		20	6		20		20
Detector 1 Type	Cl+Ex	Cl+Ex			Cl+Ex		Cl+Ex	Cl+Ex		Cl+Ex		Cl+Ex
Detector 1 Channel												
Detector 1 Extend (s)	0.0	0.0			0.0		0.0	0.0		0.0		0.0
Detector 1 Queue (s)	0.0	0.0			0.0		0.0	0.0		0.0		0.0
Detector 1 Delay (s)	0.0	0.0			0.0		0.0	0.0		0.0		0.0
Detector 2 Position(ft)		94			94			94				
Detector 2 Size(ft)		6			6			6				
Detector 2 Type		Cl+Ex			Cl+Ex			Cl+Ex				
Detector 2 Channel												
Detector 2 Extend (s)		0.0			0.0			0.0				

Lanes, Volumes, Timings

2028 Opening Year No Project Conditions

10: US 101 NB Off Ramp/Lakewood Drive & Old Redwood Highway

Timing Plan: A.M. PEAK



Lane Group	EBL	EBT	EBR	WBL	WBT	WBR	NBL	NBT	NBR	SBL	SBT	SBR
Turn Type	Prot	NA			NA		Split	NA		Prot		pm+ov
Protected Phases	5	2			6		8	8		7		5
Permitted Phases												5 8
Detector Phase	5	2			6		8	8		7		5
Switch Phase												
Minimum Initial (s)	7.0	10.0			10.0		10.0	10.0		7.0		7.0
Minimum Split (s)	11.0	32.1			32.1		33.7	33.7		11.0		11.0
Total Split (s)	13.0	45.3			32.3		33.7	33.7		11.0		13.0
Total Split (%)	14.4%	50.3%			35.9%		37.4%	37.4%		12.2%		14.4%
Maximum Green (s)	9.0	40.2			27.2		29.0	29.0		7.0		9.0
Yellow Time (s)	3.0	4.1			4.1		3.7	3.7		3.0		3.0
All-Red Time (s)	1.0	1.0			1.0		1.0	1.0		1.0		1.0
Lost Time Adjust (s)	0.0	0.0			0.0		0.0	0.0		0.0		0.0
Total Lost Time (s)	4.0	5.1			5.1		4.7	4.7		4.0		4.0
Lead/Lag	Lead				Lag		Lag	Lag		Lead		Lead
Lead-Lag Optimize?	Yes				Yes		Yes	Yes		Yes		Yes
Vehicle Extension (s)	3.0	3.0			3.0		3.0	3.0		3.0		3.0
Recall Mode	None	Max			Max		None	None		None		None
Walk Time (s)		7.0			7.0		7.0	7.0				
Flash Don't Walk (s)		20.0			17.0		22.0	22.0				
Pedestrian Calls (#/hr)		0			0		0	0				
Act Effct Green (s)	8.6	40.4			27.7		17.7	17.7		7.0		31.1
Actuated g/C Ratio	0.11	0.51			0.35		0.22	0.22		0.09		0.39
v/c Ratio	0.54	0.21			0.66		0.61	0.59		0.50		0.86
Control Delay (s/veh)	40.3	12.5			24.4		34.9	27.7		41.8		24.5
Queue Delay	0.0	0.0			0.0		0.0	0.0		0.0		0.0
Total Delay (s/veh)	40.3	12.5			24.4		34.9	27.7		41.8		24.5
LOS	D	B			C		C	C		D		C
Approach Delay (s/veh)		26.6			24.4			30.1				27.6
Approach LOS		C			C			C				C

Intersection Summary

Area Type: Other  
 Cycle Length: 90  
 Actuated Cycle Length: 79  
 Natural Cycle: 90  
 Control Type: Actuated-Uncoordinated  
 Maximum v/c Ratio: 0.86  
 Intersection Signal Delay (s/veh): 27.1  
 Intersection LOS: C  
 Intersection Capacity Utilization 81.6%  
 ICU Level of Service D  
 Analysis Period (min) 15

Splits and Phases: 10: US 101 NB Off Ramp/Lakewood Drive & Old Redwood Highway

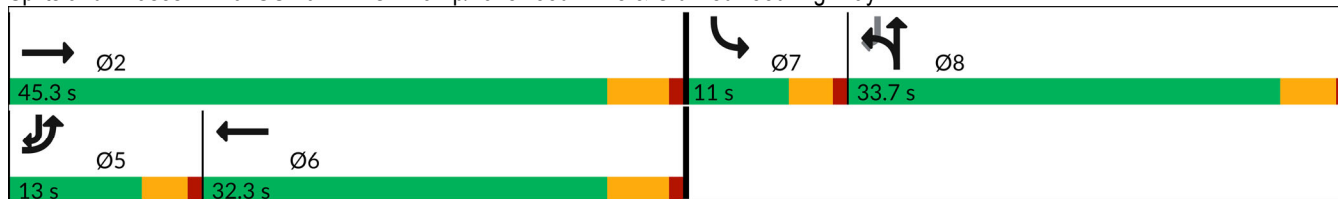

Lanes, Volumes, Timings  
 11: Old Redwood Highway & US 101 NB On Ramp

2028 Opening Year No Project Conditions  
 Timing Plan: A.M. PEAK

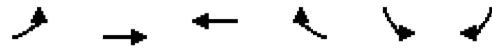

Lane Group	EBL	EBT	WBT	WBR	SBL	SBR
Lane Configurations	↶	↷	↶	↷		
Traffic Volume (vph)	98	340	1152	216	0	0
Future Volume (vph)	98	340	1152	216	0	0
Ideal Flow (vphp)	1900	1900	1900	1900	1900	1900
Storage Length (ft)	245			0	0	0
Storage Lanes	1			0	0	0
Taper Length (ft)	50				25	
Lane Util. Factor	1.00	0.95	0.95	0.95	1.00	1.00
Ped Bike Factor						
Frt			0.976			
Flt Protected	0.950					
Satd. Flow (prot)	1770	3539	3454	0	0	0
Flt Permitted	0.950					
Satd. Flow (perm)	1770	3539	3454	0	0	0
Link Speed (mph)		35	35		30	
Link Distance (ft)		531	226		299	
Travel Time (s)		10.3	4.4		6.8	
Confl. Peds. (#/hr)	9					
Confl. Bikes (#/hr)				1		
Peak Hour Factor	0.81	0.81	0.89	0.89	0.25	0.25
Adj. Flow (vph)	121	420	1294	243	0	0
Shared Lane Traffic (%)						
Lane Group Flow (vph)	121	420	1537	0	0	0
Enter Blocked Intersection	No	No	No	No	No	No
Lane Alignment	Left	Left	Left	Right	Left	Right
Median Width(ft)		12	12		0	
Link Offset(ft)		0	0		0	
Crosswalk Width(ft)		16	16		16	
Two way Left Turn Lane						
Headway Factor	1.00	1.00	1.00	1.00	1.00	1.00
Turning Speed (mph)	15			9	15	9
Sign Control		Free	Free		Free	

Intersection Summary	
Area Type:	Other
Control Type:	Unsignalized
Intersection Capacity Utilization	74.7%
Analysis Period (min)	15
	ICU Level of Service D

Lanes, Volumes, Timings

2028 Opening Year No Project Conditions

12: US 101 SB On Ramp/US 101 SB Off Ramp & Old Redwood Highway

Timing Plan: A.M. PEAK



Lane Group	EBL	EBT	EBR	WBL	WBT	WBR	NBL	NBT	NBR	SBL	SBT	SBR
Lane Configurations		↑↑	↗	↘	↑↑					↘	↕	
Traffic Volume (vph)	0	339	337	584	574	0	0	0	0	105	1	74
Future Volume (vph)	0	339	337	584	574	0	0	0	0	105	1	74
Ideal Flow (vphpl)	1900	1900	1900	1900	1900	1900	1900	1900	1900	1900	1900	1900
Storage Length (ft)	0		0	250		0	0		0	420		0
Storage Lanes	0		1	0		0	0		0	1		0
Taper Length (ft)	25			165			25			75		
Lane Util. Factor	1.00	0.95	1.00	1.00	0.95	1.00	1.00	1.00	1.00	0.95	0.95	1.00
Ped Bike Factor			0.98	1.00								
Frt			0.850								0.870	
Flt Protected				0.950						0.950	0.994	
Satd. Flow (prot)	0	3539	1583	1770	3539	0	0	0	0	1681	1530	0
Flt Permitted				0.950						0.950	0.994	
Satd. Flow (perm)	0	3539	1558	1767	3539	0	0	0	0	1681	1530	0
Right Turn on Red			Yes			Yes			Yes			Yes
Satd. Flow (RTOR)			350								91	
Link Speed (mph)		35			35			30			30	
Link Distance (ft)		423			531			621			831	
Travel Time (s)		8.2			10.3			14.1			18.9	
Confl. Peds. (#/hr)	10		3	3		10						
Confl. Bikes (#/hr)			2									
Peak Hour Factor	0.92	0.92	0.92	0.89	0.89	0.89	0.25	0.25	0.25	0.81	0.81	0.81
Adj. Flow (vph)	0	368	366	656	645	0	0	0	0	130	1	91
Shared Lane Traffic (%)										10%		
Lane Group Flow (vph)	0	368	366	656	645	0	0	0	0	117	105	0
Enter Blocked Intersection	No	No	No	No	No	No	No	No	No	No	No	No
Lane Alignment	Left	Left	Right	Left	Left	Right	Left	Left	Right	Left	Left	Right
Median Width(ft)		24			24			12			12	
Link Offset(ft)		0			0			0			0	
Crosswalk Width(ft)		16			16			16			16	
Two way Left Turn Lane												
Headway Factor	1.00	1.00	1.00	1.00	1.00	1.00	1.00	1.00	1.00	1.00	1.00	1.00
Turning Speed (mph)	15		9	15		9	15		9	15		9
Number of Detectors		2	1	1	2					1	2	
Detector Template		Thru	Right	Left	Thru					Left	Thru	
Leading Detector (ft)		100	20	20	100					20	100	
Trailing Detector (ft)		0	0	0	0					0	0	
Detector 1 Position(ft)		0	0	0	0					0	0	
Detector 1 Size(ft)		6	20	20	6					20	6	
Detector 1 Type		Cl+Ex	Cl+Ex	Cl+Ex	Cl+Ex					Cl+Ex	Cl+Ex	
Detector 1 Channel												
Detector 1 Extend (s)		0.0	0.0	0.0	0.0					0.0	0.0	
Detector 1 Queue (s)		0.0	0.0	0.0	0.0					0.0	0.0	
Detector 1 Delay (s)		0.0	0.0	0.0	0.0					0.0	0.0	
Detector 2 Position(ft)		94			94							94
Detector 2 Size(ft)		6			6							6
Detector 2 Type		Cl+Ex			Cl+Ex							Cl+Ex
Detector 2 Channel												
Detector 2 Extend (s)		0.0			0.0							0.0

Lanes, Volumes, Timings

2028 Opening Year No Project Conditions

12: US 101 SB On Ramp/US 101 SB Off Ramp & Old Redwood Highway

Timing Plan: A.M. PEAK



Lane Group	EBL	EBT	EBR	WBL	WBT	WBR	NBL	NBT	NBR	SBL	SBT	SBR
Turn Type		NA	Perm	Prot	NA					Perm	NA	
Protected Phases		6		5	2						8	
Permitted Phases			6							8		
Detector Phase		6	6	5	2					8	8	
Switch Phase												
Minimum Initial (s)		10.0	10.0	7.0	10.0					10.0	10.0	
Minimum Split (s)		32.1	32.1	11.0	38.1					14.7	14.7	
Total Split (s)		32.3	32.3	33.0	65.3					14.7	14.7	
Total Split (%)		40.4%	40.4%	41.3%	81.6%					18.4%	18.4%	
Maximum Green (s)		27.2	27.2	29.0	60.2					10.0	10.0	
Yellow Time (s)		4.1	4.1	3.0	4.1					3.7	3.7	
All-Red Time (s)		1.0	1.0	1.0	1.0					1.0	1.0	
Lost Time Adjust (s)		0.0	0.0	0.0	0.0					0.0	0.0	
Total Lost Time (s)		5.1	5.1	4.0	5.1					4.7	4.7	
Lead/Lag		Lag	Lag	Lead								
Lead-Lag Optimize?		Yes	Yes	Yes								
Vehicle Extension (s)		3.0	3.0	3.0	3.0					3.0	3.0	
Recall Mode		Max	Max	None	Max					None	None	
Walk Time (s)		7.0	7.0		7.0							
Flash Don't Walk (s)		20.0	20.0		25.0							
Pedestrian Calls (#/hr)		0	0		0							
Act Effct Green (s)		27.2	27.2	29.0	60.2					10.0	10.0	
Actuated g/C Ratio		0.34	0.34	0.36	0.75					0.13	0.13	
v/c Ratio		0.31	0.48	1.02	0.24					0.56	0.39	
Control Delay (s/veh)		20.3	5.2	69.4	3.2					43.9	14.4	
Queue Delay		0.0	0.0	0.0	0.0					0.0	0.0	
Total Delay (s/veh)		20.3	5.2	69.4	3.2					43.9	14.4	
LOS		C	A	E	A					D	B	
Approach Delay (s/veh)		12.8			36.6						30.0	
Approach LOS		B			D						C	

Intersection Summary

Area Type: Other

Cycle Length: 80

Actuated Cycle Length: 80

Natural Cycle: 80

Control Type: Actuated-Uncoordinated

Maximum v/c Ratio: 1.02

Intersection Signal Delay (s/veh): 28.2

Intersection LOS: C

Intersection Capacity Utilization 74.7%

ICU Level of Service D





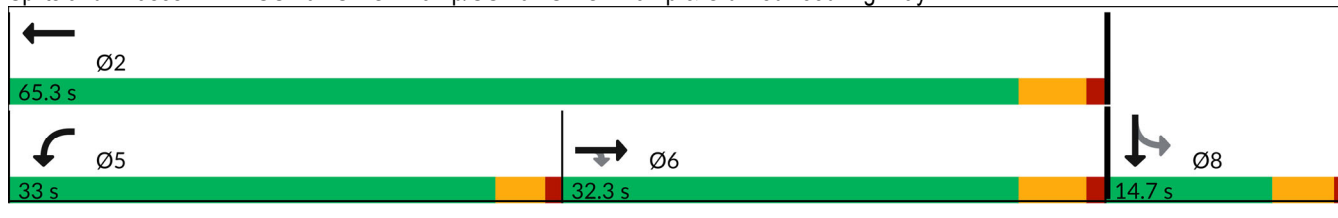

















Analysis Period (min) 15

Splits and Phases: 12: US 101 SB On Ramp/US 101 SB Off Ramp & Old Redwood Highway



Lanes, Volumes, Timings  
1: Old Redwood Hwy & Shiloh Road

2028 Opening Year No Project Conditions  
Timing Plan: P.M. Peak

												
Lane Group	EBL	EBT	EBR	WBL	WBT	WBR	NBL	NBT	NBR	SBL	SBT	SBR
Lane Configurations												
Traffic Volume (vph)	290	98	208	42	91	18	186	386	24	26	269	183
Future Volume (vph)	290	98	208	42	91	18	186	386	24	26	269	183
Ideal Flow (vphpl)	1900	1900	1900	1900	1900	1900	1900	1900	1900	1900	1900	1900
Storage Length (ft)	375		140	0		50	200		98	130		93
Storage Lanes	1		1	0		1	1		1	1		1
Taper Length (ft)	50			25			60			93		
Lane Util. Factor	1.00	1.00	1.00	1.00	1.00	1.00	1.00	1.00	1.00	1.00	1.00	1.00
Ped Bike Factor	1.00					0.98	1.00		0.98			0.97
Frt			0.850			0.850			0.850			0.850
Flt Protected	0.950				0.984		0.950			0.950		
Satd. Flow (prot)	1770	1863	1583	0	1833	1583	1770	1863	1583	1770	1863	1583
Flt Permitted	0.950				0.984		0.950			0.950		
Satd. Flow (perm)	1767	1863	1583	0	1833	1549	1767	1863	1546	1770	1863	1542
Right Turn on Red			Yes			Yes			Yes			Yes
Satd. Flow (RTOR)			214			105			77			116
Link Speed (mph)		40			40			45				40
Link Distance (ft)		1789			608			748				775
Travel Time (s)		30.5			10.4			11.3				13.2
Confl. Peds. (#/hr)	1						1	1				1
Confl. Bikes (#/hr)									3			3
Peak Hour Factor	0.97	0.97	0.97	0.91	0.91	0.91	0.93	0.93	0.93	0.93	0.93	0.93
Adj. Flow (vph)	299	101	214	46	100	20	200	415	26	28	289	197
Shared Lane Traffic (%)												
Lane Group Flow (vph)	299	101	214	0	146	20	200	415	26	28	289	197
Enter Blocked Intersection	No	No	No	No	No	No	No	No	No	No	No	No
Lane Alignment	Left	Left	Right	Left	Left	Right	Left	Left	Right	Left	Left	Right
Median Width(ft)		12			12			12				12
Link Offset(ft)		0			0			0				0
Crosswalk Width(ft)		16			16			16				16
Two way Left Turn Lane												
Headway Factor	1.00	1.00	1.00	1.00	1.00	1.00	1.00	1.00	1.00	1.00	1.00	1.00
Turning Speed (mph)	15		9	15		9	15		9	15		9
Number of Detectors	1	2	1	1	2	1	1	2	1	1	2	1
Detector Template	Left	Thru	Right	Left	Thru	Right	Left	Thru	Right	Left	Thru	Right
Leading Detector (ft)	20	100	20	20	100	20	20	100	20	20	100	20
Trailing Detector (ft)	0	0	0	0	0	0	0	0	0	0	0	0
Detector 1 Position(ft)	0	0	0	0	0	0	0	0	0	0	0	0
Detector 1 Size(ft)	20	6	20	20	6	20	20	6	20	20	6	20
Detector 1 Type	Cl+Ex	Cl+Ex	Cl+Ex	Cl+Ex	Cl+Ex	Cl+Ex	Cl+Ex	Cl+Ex	Cl+Ex	Cl+Ex	Cl+Ex	Cl+Ex
Detector 1 Channel												
Detector 1 Extend (s)	0.0	0.0	0.0	0.0	0.0	0.0	0.0	0.0	0.0	0.0	0.0	0.0
Detector 1 Queue (s)	0.0	0.0	0.0	0.0	0.0	0.0	0.0	0.0	0.0	0.0	0.0	0.0
Detector 1 Delay (s)	0.0	0.0	0.0	0.0	0.0	0.0	0.0	0.0	0.0	0.0	0.0	0.0
Detector 2 Position(ft)		94			94			94				94
Detector 2 Size(ft)		6			6			6				6
Detector 2 Type		Cl+Ex			Cl+Ex			Cl+Ex				Cl+Ex
Detector 2 Channel												
Detector 2 Extend (s)		0.0			0.0			0.0				0.0

Lanes, Volumes, Timings  
1: Old Redwood Hwy & Shiloh Road

2028 Opening Year No Project Conditions  
Timing Plan: P.M. Peak

Lane Group	EBL	EBT	EBR	WBL	WBT	WBR	NBL	NBT	NBR	SBL	SBT	SBR
Turn Type	Split	NA	Perm	Split	NA	Perm	Prot	NA	Perm	Prot	NA	Perm
Protected Phases	2	2		6	6		3	8		7	4	
Permitted Phases			2			6			8			4
Detector Phase	2	2	2	6	6	6	3	8	8	7	4	4
Switch Phase												
Minimum Initial (s)	5.0	5.0	5.0	5.0	5.0	5.0	5.0	5.0	5.0	5.0	5.0	5.0
Minimum Split (s)	34.5	34.5	34.5	42.5	42.5	42.5	8.5	46.5	46.5	8.5	39.5	39.5
Total Split (s)	35.0	35.0	35.0	42.5	42.5	42.5	18.0	48.0	48.0	9.5	39.5	39.5
Total Split (%)	25.9%	25.9%	25.9%	31.5%	31.5%	31.5%	13.3%	35.6%	35.6%	7.0%	29.3%	29.3%
Maximum Green (s)	30.5	30.5	30.5	38.0	38.0	38.0	14.5	43.5	43.5	6.0	35.0	35.0
Yellow Time (s)	3.5	3.5	3.5	3.5	3.5	3.5	3.0	3.5	3.5	3.0	3.5	3.5
All-Red Time (s)	1.0	1.0	1.0	1.0	1.0	1.0	0.5	1.0	1.0	0.5	1.0	1.0
Lost Time Adjust (s)	0.0	0.0	0.0		0.0	0.0	0.0	0.0	0.0	0.0	0.0	0.0
Total Lost Time (s)	4.5	4.5	4.5		4.5	4.5	3.5	4.5	4.5	3.5	4.5	4.5
Lead/Lag	Lead	Lead	Lead	Lag	Lag	Lag	Lead	Lag	Lag	Lead	Lag	Lag
Lead-Lag Optimize?	Yes	Yes	Yes	Yes	Yes	Yes	Yes	Yes	Yes	Yes	Yes	Yes
Vehicle Extension (s)	3.0	3.0	3.0	3.0	3.0	3.0	3.0	3.0	3.0	3.0	3.0	3.0
Recall Mode	None	None	None	None	None	None	None	None	None	None	None	None
Walk Time (s)	7.0	7.0	7.0	7.0	7.0	7.0		7.0	7.0		7.0	7.0
Flash Don't Walk (s)	23.0	23.0	23.0	31.0	31.0	31.0		35.0	35.0		28.0	28.0
Pedestrian Calls (#/hr)	0	0	0	0	0	0		0	0		0	0
Act Effct Green (s)	21.2	21.2	21.2		13.0	13.0	15.0	33.3	33.3	6.1	19.7	19.7
Actuated g/C Ratio	0.24	0.24	0.24		0.15	0.15	0.17	0.38	0.38	0.07	0.23	0.23
v/c Ratio	0.69	0.22	0.39		0.53	0.06	0.65	0.58	0.04	0.23	0.68	0.45
Control Delay (s/veh)	40.1	29.3	6.6		44.2	0.4	49.3	28.6	0.1	49.8	40.9	17.1
Queue Delay	0.0	0.0	0.0		0.0	0.0	0.0	0.0	0.0	0.0	0.0	0.0
Total Delay (s/veh)	40.1	29.3	6.6		44.2	0.4	49.3	28.6	0.1	49.8	40.9	17.1
LOS	D	C	A		D	A	D	C	A	D	D	B
Approach Delay (s/veh)		26.6			39.0			33.9			32.3	
Approach LOS		C			D			C			C	

Intersection Summary

Area Type: Other  
 Cycle Length: 135  
 Actuated Cycle Length: 86.7  
 Natural Cycle: 135  
 Control Type: Actuated-Uncoordinated  
 Maximum v/c Ratio: 0.69  
 Intersection Signal Delay (s/veh): 31.6  
 Intersection LOS: C  
 Intersection Capacity Utilization 58.5%  
 ICU Level of Service B  
 Analysis Period (min) 15



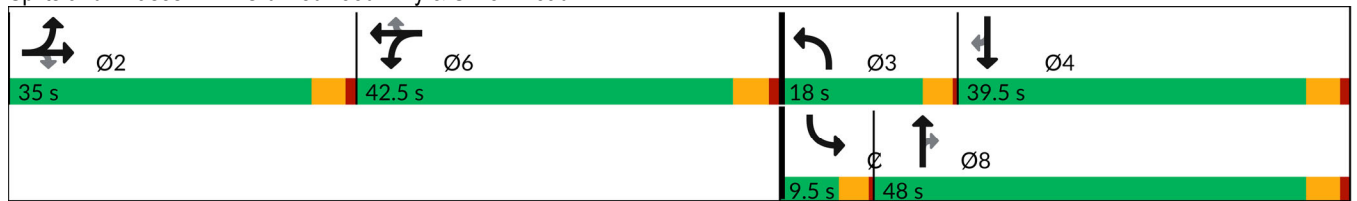





















Splits and Phases: 1: Old Redwood Hwy & Shiloh Road





Lanes, Volumes, Timings  
2: Shiloh Road & Hembree Ln













2028 Opening Year No Project Conditions  
Timing Plan: P.M. Peak

												
Lane Group	EBL	EBT	EBR	WBL	WBT	WBR	NBL	NBT	NBR	SBL	SBT	SBR
Lane Configurations	 			 	 						 	
Traffic Volume (vph)	700	435	44	24	323	165	65	11	15	194	11	565
Future Volume (vph)	700	435	44	24	323	165	65	11	15	194	11	565
Ideal Flow (vphpl)	1900	1900	1900	1900	1900	1900	1900	1900	1900	1900	1900	1900
Storage Length (ft)	0		0	100		130	0		0	0		0
Storage Lanes	2		0	1		1	1		0	0		1
Taper Length (ft)	25			50			25			25		
Lane Util. Factor	0.97	1.00	1.00	1.00	0.95	0.95	1.00	1.00	1.00	1.00	1.00	1.00
Ped Bike Factor	1.00				1.00							
Frt		0.987			0.949			0.913				0.850
Flt Protected	0.950			0.950			0.950				0.955	
Satd. Flow (prot)	3433	1839	0	1770	3344	0	1770	1701	0	0	1779	1583
Flt Permitted	0.950			0.950			0.950				0.955	
Satd. Flow (perm)	3429	1839	0	1770	3344	0	1770	1701	0	0	1779	1583
Right Turn on Red			Yes			Yes			Yes			Yes
Satd. Flow (RTOR)		9			134			15				369
Link Speed (mph)		40			40			30				35
Link Distance (ft)		302			1789			216				381
Travel Time (s)		5.1			30.5			4.9				7.4
Confl. Peds. (#/hr)	2					2						
Peak Hour Factor	0.94	0.94	1.00	1.00	0.87	0.87	1.00	1.00	1.00	0.95	1.00	0.95
Adj. Flow (vph)	745	463	44	24	371	190	65	11	15	204	11	595
Shared Lane Traffic (%)												
Lane Group Flow (vph)	745	507	0	24	561	0	65	26	0	0	215	595
Enter Blocked Intersection	No	No	No	No	No	No	No	No	No	No	No	No
Lane Alignment	Left	Left	Right	Left	Left	Right	Left	Left	Right	Left	Left	Right
Median Width(ft)		24			24			12				12
Link Offset(ft)		0			0			0				0
Crosswalk Width(ft)		16			16			16				16
Two way Left Turn Lane												
Headway Factor	1.00	1.00	1.00	1.00	1.00	1.00	1.00	1.00	1.00	1.00	1.00	1.00
Turning Speed (mph)	15		60	60		9	60		60	15		9
Number of Detectors	1	2		1	2		1	2		1	2	1
Detector Template	Left	Thru		Left	Thru		Left	Thru		Left	Thru	Right
Leading Detector (ft)	20	100		20	100		20	100		20	100	20
Trailing Detector (ft)	0	0		0	0		0	0		0	0	0
Detector 1 Position(ft)	0	0		0	0		0	0		0	0	0
Detector 1 Size(ft)	20	6		20	6		20	6		20	6	20
Detector 1 Type	Cl+Ex	Cl+Ex		Cl+Ex	Cl+Ex		Cl+Ex	Cl+Ex		Cl+Ex	Cl+Ex	Cl+Ex
Detector 1 Channel												
Detector 1 Extend (s)	0.0	0.0		0.0	0.0		0.0	0.0		0.0	0.0	0.0
Detector 1 Queue (s)	0.0	0.0		0.0	0.0		0.0	0.0		0.0	0.0	0.0
Detector 1 Delay (s)	0.0	0.0		0.0	0.0		0.0	0.0		0.0	0.0	0.0
Detector 2 Position(ft)		94			94			94				94
Detector 2 Size(ft)		6			6			6				6
Detector 2 Type		Cl+Ex			Cl+Ex			Cl+Ex				Cl+Ex
Detector 2 Channel												
Detector 2 Extend (s)		0.0			0.0			0.0				0.0
Turn Type	Prot	NA		Prot	NA		Split	NA		Split	NA	pt+ov

Lanes, Volumes, Timings  
2: Shiloh Road & Hembree Ln

2028 Opening Year No Project Conditions

Timing Plan: P.M. Peak

												
Lane Group	EBL	EBT	EBR	WBL	WBT	WBR	NBL	NBT	NBR	SBL	SBT	SBR
Protected Phases	5	2		1	6		8	8		4	4	4 5
Permitted Phases												
Detector Phase	5	2		1	6		8	8		4	4	4 5
Switch Phase												
Minimum Initial (s)	3.0	5.0		5.0	5.0		5.0	5.0		5.0	5.0	
Minimum Split (s)	7.5	9.5		9.5	43.5		9.5	9.5		9.5	9.5	
Total Split (s)	21.0	57.0		9.5	45.5		9.5	9.5		14.0	14.0	
Total Split (%)	23.3%	63.3%		10.6%	50.6%		10.6%	10.6%		15.6%	15.6%	
Maximum Green (s)	17.0	53.0		5.5	41.5		5.5	5.5		10.0	10.0	
Yellow Time (s)	3.0	3.0		3.0	3.0		3.0	3.0		3.0	3.0	
All-Red Time (s)	1.0	1.0		1.0	1.0		1.0	1.0		1.0	1.0	
Lost Time Adjust (s)	0.0	0.0		0.0	0.0		0.0	0.0		0.0	0.0	
Total Lost Time (s)	4.0	4.0		4.0	4.0		4.0	4.0		4.0	4.0	
Lead/Lag	Lead	Lag		Lead	Lag							
Lead-Lag Optimize?	Yes	Yes		Yes	Yes							
Vehicle Extension (s)	3.0	3.0		3.0	3.0		3.0	3.0		3.0	3.0	
Recall Mode	None	None		None	None		None	None		None	None	
Walk Time (s)					7.0							
Flash Don't Walk (s)					32.0							
Pedestrian Calls (#/hr)					1							
Act Effct Green (s)	17.6	37.1		5.7	16.7		5.7	5.7		10.4	29.1	
Actuated g/C Ratio	0.27	0.58		0.09	0.26		0.09	0.09		0.16	0.45	
v/c Ratio	0.79	0.48		0.15	0.58		0.42	0.16		0.75	0.65	
Control Delay (s/veh)	32.8	10.4		35.2	17.5		42.1	24.4		48.7	9.5	
Queue Delay	0.0	0.0		0.0	0.0		0.0	0.0		0.0	0.0	
Total Delay (s/veh)	32.8	10.4		35.2	17.5		42.1	24.4		48.7	9.5	
LOS	C	B		D	B		D	C		D	A	
Approach Delay (s/veh)		23.7			18.2			37.0			19.9	
Approach LOS		C			B			D			B	

Intersection Summary

Area Type:	Other
Cycle Length:	90
Actuated Cycle Length:	64.5
Natural Cycle:	90
Control Type:	Actuated-Uncoordinated
Maximum v/c Ratio:	0.79
Intersection Signal Delay (s/veh):	21.9
Intersection LOS:	C
Intersection Capacity Utilization:	64.6%
ICU Level of Service:	C
Analysis Period (min):	15

Splits and Phases: 2: Shiloh Road & Hembree Ln



Lanes, Volumes, Timings  
3: US 101 NB Off-Ramp & Shiloh Road

2028 Opening Year No Project Conditions

Timing Plan: P.M. Peak

	→	↘	↙	←	↖	↗
Lane Group	EBT	EBR	WBL	WBT	NBL	NBR
Lane Configurations	↑↑			↑	↘	↗
Traffic Volume (vph)	435	0	0	668	599	749
Future Volume (vph)	435	0	0	668	599	749
Ideal Flow (vphpl)	1900	1900	1900	1900	1900	1900
Storage Length (ft)		0	0		0	265
Storage Lanes		0	0		1	2
Taper Length (ft)			25		25	
Lane Util. Factor	0.95	1.00	1.00	1.00	1.00	0.88
Frt						0.850
Flt Protected					0.950	
Satd. Flow (prot)	3539	0	0	1863	1770	2787
Flt Permitted					0.950	
Satd. Flow (perm)	3539	0	0	1863	1770	2787
Right Turn on Red		Yes				Yes
Satd. Flow (RTOR)						517
Link Speed (mph)	40			40	30	
Link Distance (ft)	186			371	769	
Travel Time (s)	3.2			6.3	17.5	
Peak Hour Factor	0.94	0.94	0.97	0.97	0.90	0.90
Adj. Flow (vph)	463	0	0	689	666	832
Shared Lane Traffic (%)						
Lane Group Flow (vph)	463	0	0	689	666	832
Enter Blocked Intersection	No	No	No	No	No	No
Lane Alignment	Left	Right	Left	Left	Left	Right
Median Width(ft)	0			0	12	
Link Offset(ft)	0			0	0	
Crosswalk Width(ft)	16			16	16	
Two way Left Turn Lane						
Headway Factor	1.00	1.00	1.00	1.00	1.00	1.00
Turning Speed (mph)		9	15		15	9
Number of Detectors	2			2	1	1
Detector Template	Thru			Thru	Left	Right
Leading Detector (ft)	100			100	20	20
Trailing Detector (ft)	0			0	0	0
Detector 1 Position(ft)	0			0	0	0
Detector 1 Size(ft)	6			6	20	20
Detector 1 Type	Cl+Ex			Cl+Ex	Cl+Ex	Cl+Ex
Detector 1 Channel						
Detector 1 Extend (s)	0.0			0.0	0.0	0.0
Detector 1 Queue (s)	0.0			0.0	0.0	0.0
Detector 1 Delay (s)	0.0			0.0	0.0	0.0
Detector 2 Position(ft)	94			94		
Detector 2 Size(ft)	6			6		
Detector 2 Type	Cl+Ex			Cl+Ex		
Detector 2 Channel						
Detector 2 Extend (s)	0.0			0.0		
Turn Type	NA			NA	Prot	Perm
Protected Phases	2			6	8	
Permitted Phases						8

Lanes, Volumes, Timings  
 3: US 101 NB Off-Ramp & Shiloh Road

2028 Opening Year No Project Conditions  
 Timing Plan: P.M. Peak

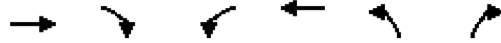

Lane Group	EBT	EBR	WBL	WBT	NBL	NBR
Detector Phase	2			6	8	8
Switch Phase						
Minimum Initial (s)	5.0			5.0	5.0	5.0
Minimum Split (s)	9.0			9.0	9.0	9.0
Total Split (s)	37.0			37.0	35.0	35.0
Total Split (%)	51.4%			51.4%	48.6%	48.6%
Maximum Green (s)	33.0			33.0	31.0	31.0
Yellow Time (s)	3.0			3.0	3.0	3.0
All-Red Time (s)	1.0			1.0	1.0	1.0
Lost Time Adjust (s)	0.0			0.0	0.0	0.0
Total Lost Time (s)	4.0			4.0	4.0	4.0
Lead/Lag						
Lead-Lag Optimize?						
Vehicle Extension (s)	3.0			3.0	3.0	3.0
Recall Mode	None			None	None	None
Act Effect Green (s)	28.1			28.1	28.3	28.3
Actuated g/C Ratio	0.43			0.43	0.44	0.44
v/c Ratio	0.30			0.85	0.86	0.55
Control Delay (s/veh)	12.7			28.8	31.2	6.7
Queue Delay	0.0			0.0	0.0	0.0
Total Delay (s/veh)	12.7			28.8	31.2	6.7
LOS	B			C	C	A
Approach Delay (s/veh)	12.7			28.8	17.6	
Approach LOS	B			C	B	

Intersection Summary

Area Type:	Other
Cycle Length:	72
Actuated Cycle Length:	64.7
Natural Cycle:	60
Control Type:	Actuated-Uncoordinated
Maximum v/c Ratio:	0.86
Intersection Signal Delay (s/veh):	19.6
Intersection LOS:	B
Intersection Capacity Utilization:	113.3%
ICU Level of Service:	H
Analysis Period (min):	15

Splits and Phases: 3: US 101 NB Off-Ramp & Shiloh Road

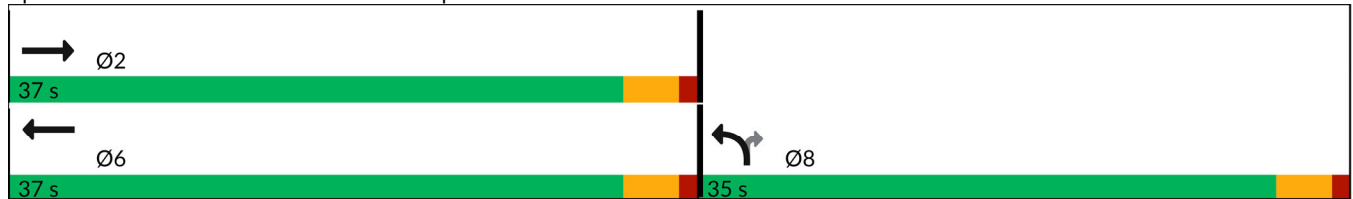

Lanes, Volumes, Timings  
4: Shiloh Road & US 101 SB Off-Ramp

2028 Opening Year No Project Conditions

Timing Plan: P.M. Peak

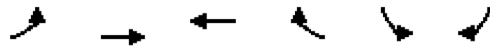

Lane Group	EBL	EBT	WBT	WBR	SBL	SBR
Lane Configurations		↑	↑		↘	↘
Traffic Volume (vph)	0	498	714	0	140	146
Future Volume (vph)	0	498	714	0	140	146
Ideal Flow (vphp)	1900	1900	1900	1900	1900	1900
Storage Length (ft)	0			0	0	275
Storage Lanes	0			0	1	1
Taper Length (ft)	25				25	
Lane Util. Factor	1.00	1.00	1.00	1.00	1.00	1.00
Ped Bike Factor						0.98
Frt						0.850
Flt Protected					0.950	
Satd. Flow (prot)	0	1863	1863	0	1770	1583
Flt Permitted					0.950	
Satd. Flow (perm)	0	1863	1863	0	1770	1548
Right Turn on Red				Yes		Yes
Satd. Flow (RTOR)						157
Link Speed (mph)		40	40		30	
Link Distance (ft)		225	306		486	
Travel Time (s)		3.8	5.2		11.0	
Confl. Peds. (#/hr)						1
Peak Hour Factor	0.89	0.89	0.96	0.96	0.93	0.93
Adj. Flow (vph)	0	560	744	0	151	157
Shared Lane Traffic (%)						
Lane Group Flow (vph)	0	560	744	0	151	157
Enter Blocked Intersection	No	No	No	No	No	No
Lane Alignment	Left	Left	Left	Right	Left	Right
Median Width(ft)		4	0		12	
Link Offset(ft)		0	0		0	
Crosswalk Width(ft)		16	16		16	
Two way Left Turn Lane						
Headway Factor	1.00	1.00	1.00	1.00	1.00	1.00
Turning Speed (mph)	15			9	15	9
Number of Detectors		2	2		1	1
Detector Template		Thru	Thru		Left	Right
Leading Detector (ft)		100	100		20	20
Trailing Detector (ft)		0	0		0	0
Detector 1 Position(ft)		0	0		0	0
Detector 1 Size(ft)		6	6		20	20
Detector 1 Type		Cl+Ex	Cl+Ex		Cl+Ex	Cl+Ex
Detector 1 Channel						
Detector 1 Extend (s)		0.0	0.0		0.0	0.0
Detector 1 Queue (s)		0.0	0.0		0.0	0.0
Detector 1 Delay (s)		0.0	0.0		0.0	0.0
Detector 2 Position(ft)		94	94			
Detector 2 Size(ft)		6	6			
Detector 2 Type		Cl+Ex	Cl+Ex			
Detector 2 Channel						
Detector 2 Extend (s)		0.0	0.0			
Turn Type		NA	NA		Perm	Perm

Lanes, Volumes, Timings  
4: Shiloh Road & US 101 SB Off-Ramp

2028 Opening Year No Project Conditions  
Timing Plan: P.M. Peak

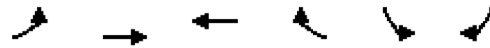

Lane Group	EBL	EBT	WBT	WBR	SBL	SBR
Protected Phases		2	6			
Permitted Phases					4	4
Detector Phase		2	6		4	4
Switch Phase						
Minimum Initial (s)		5.0	5.0		5.0	5.0
Minimum Split (s)		9.0	38.0		9.0	9.0
Total Split (s)		69.0	69.0		21.0	21.0
Total Split (%)		76.7%	76.7%		23.3%	23.3%
Maximum Green (s)		65.0	65.0		17.0	17.0
Yellow Time (s)		3.0	3.0		3.0	3.0
All-Red Time (s)		1.0	1.0		1.0	1.0
Lost Time Adjust (s)		0.0	0.0		0.0	0.0
Total Lost Time (s)		4.0	4.0		4.0	4.0
Lead/Lag						
Lead-Lag Optimize?						
Vehicle Extension (s)		3.0	3.0		3.0	3.0
Recall Mode		None	None		None	None
Walk Time (s)			7.0			
Flash Don't Walk (s)			27.0			
Pedestrian Calls (#/hr)			0			
Act Effct Green (s)		23.2	23.2		9.3	9.3
Actuated g/C Ratio		0.56	0.56		0.23	0.23
v/c Ratio		0.53	0.71		0.38	0.33
Control Delay (s/veh)		7.6	10.7		19.2	6.2
Queue Delay		0.0	0.0		0.0	0.0
Total Delay (s/veh)		7.6	10.7		19.2	6.2
LOS		A	B		B	A
Approach Delay (s/veh)		7.6	10.7		12.6	
Approach LOS		A	B		B	

Intersection Summary

Area Type:	Other
Cycle Length:	90
Actuated Cycle Length:	41.1
Natural Cycle:	50
Control Type:	Actuated-Uncoordinated
Maximum v/c Ratio:	0.71
Intersection Signal Delay (s/veh):	10.0
Intersection LOS:	A
Intersection Capacity Utilization:	67.3%
ICU Level of Service:	C
Analysis Period (min):	15

Splits and Phases: 4: Shiloh Road & US 101 SB Off-Ramp

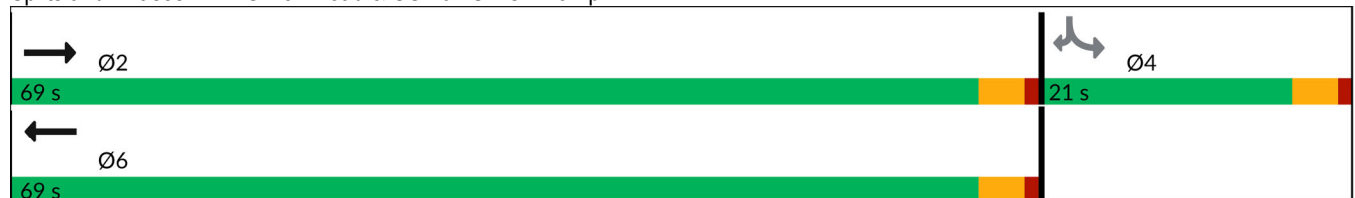

Lanes, Volumes, Timings  
5: Caletti Ave & Shiloh Road

2028 Opening Year No Project Conditions

Timing Plan: P.M. Peak

	→	↘	↙	←	↖	↗
Lane Group	EBT	EBR	WBL	WBT	NBL	NBR
Lane Configurations	↑↑		↘	↑	↘	↗
Traffic Volume (vph)	969	32	90	741	17	170
Future Volume (vph)	969	32	90	741	17	170
Ideal Flow (vphpl)	1900	1900	1900	1900	1900	1900
Storage Length (ft)		0	68		0	0
Storage Lanes		0	1		1	1
Taper Length (ft)			50		25	
Lane Util. Factor	0.95	0.95	1.00	1.00	1.00	1.00
Frt	0.995					0.850
Flt Protected			0.950		0.950	
Satd. Flow (prot)	3522	0	1770	1863	1770	1583
Flt Permitted			0.950		0.950	
Satd. Flow (perm)	3522	0	1770	1863	1770	1583
Link Speed (mph)	40			40	30	
Link Distance (ft)	1081			184	459	
Travel Time (s)	18.4			3.1	10.4	
Peak Hour Factor	0.89	0.89	0.92	0.92	0.89	0.89
Adj. Flow (vph)	1089	36	98	805	19	191
Shared Lane Traffic (%)						
Lane Group Flow (vph)	1125	0	98	805	19	191
Enter Blocked Intersection	No	No	No	No	No	No
Lane Alignment	Left	Right	Left	Left	Left	Right
Median Width(ft)	12			12	12	
Link Offset(ft)	0			0	0	
Crosswalk Width(ft)	16			16	16	
Two way Left Turn Lane						
Headway Factor	1.00	1.00	1.00	1.00	1.00	1.00
Turning Speed (mph)		9	15		15	9
Sign Control	Free			Free	Stop	
<b>Intersection Summary</b>						
Area Type:	Other					
Control Type:	Unsignalized					
Intersection Capacity Utilization	49.0%			ICU Level of Service A		
Analysis Period (min)	15					

Lanes, Volumes, Timings  
6: Conde Lane & Shiloh Road

2028 Opening Year No Project Conditions  
Timing Plan: P.M. Peak

Lane Group	EBL	EBT	EBR	WBL	WBT	WBR	NBL	NBT	NBR	SBL	SBT	SBR
Lane Configurations												
Traffic Volume (vph)	79	535	2	8	519	329	6	3	19	338	0	44
Future Volume (vph)	79	535	2	8	519	329	6	3	19	338	0	44
Ideal Flow (vphpl)	1900	1900	1900	1900	1900	1900	1900	1900	1900	1900	1900	1900
Storage Length (ft)	90		0	127		0	0		0	0		40
Storage Lanes	1		0	1		0	0		0	0		1
Taper Length (ft)	70			40			25			25		
Lane Util. Factor	1.00	0.95	0.95	1.00	0.95	0.95	1.00	1.00	1.00	1.00	1.00	1.00
Ped Bike Factor	1.00				0.99							
Frt					0.942			0.910				0.850
Flt Protected	0.950			0.950				0.989			0.950	
Satd. Flow (prot)	1770	3539	0	1770	3306	0	0	1676	0	0	1770	1583
Flt Permitted	0.950			0.950				0.989			0.950	
Satd. Flow (perm)	1767	3539	0	1770	3306	0	0	1676	0	0	1770	1583
Right Turn on Red			Yes			Yes			Yes			No
Satd. Flow (RTOR)					146			30				
Link Speed (mph)		40			40			30				35
Link Distance (ft)		815			1081			418				522
Travel Time (s)		13.9			18.4			9.5				10.2
Confl. Peds. (#/hr)	1						1					
Peak Hour Factor	0.88	0.88	0.88	0.80	0.80	0.80	0.63	0.63	0.63	0.88	0.88	0.88
Adj. Flow (vph)	90	608	2	10	649	411	10	5	30	384	0	50
Shared Lane Traffic (%)												
Lane Group Flow (vph)	90	610	0	10	1060	0	0	45	0	0	384	50
Enter Blocked Intersection	No	No	No	No	No	No	No	No	No	No	No	No
Lane Alignment	Left	Left	Right	Left	Left	Right	Left	Left	Right	Left	Left	Right
Median Width(ft)		12			12			0				0
Link Offset(ft)		0			0			0				0
Crosswalk Width(ft)		16			16			16				16
Two way Left Turn Lane												
Headway Factor	1.00	1.00	1.00	1.00	1.00	1.00	1.00	1.00	1.00	1.00	1.00	1.00
Turning Speed (mph)	15		9	15		9	15		9	15		9
Number of Detectors	1	2		1	2		1	2		1	1	1
Detector Template	Left	Thru		Left	Thru		Left	Thru		Left	Thru	Right
Leading Detector (ft)	20	100		20	100		20	100		20	30	20
Trailing Detector (ft)	0	0		0	0		0	0		0	0	0
Detector 1 Position(ft)	0	0		0	0		0	0		0	0	0
Detector 1 Size(ft)	20	6		20	6		20	6		20	30	20
Detector 1 Type	Cl+Ex	Cl+Ex		Cl+Ex	Cl+Ex		Cl+Ex	Cl+Ex		Cl+Ex	Cl+Ex	Cl+Ex
Detector 1 Channel												
Detector 1 Extend (s)	0.0	0.0		0.0	0.0		0.0	0.0		0.0	0.0	0.0
Detector 1 Queue (s)	0.0	0.0		0.0	0.0		0.0	0.0		0.0	0.0	0.0
Detector 1 Delay (s)	0.0	0.0		0.0	0.0		0.0	0.0		0.0	0.0	0.0
Detector 2 Position(ft)		94			94			94				
Detector 2 Size(ft)		6			6			6				
Detector 2 Type		Cl+Ex			Cl+Ex			Cl+Ex				
Detector 2 Channel												
Detector 2 Extend (s)		0.0			0.0			0.0				
Turn Type	Prot	NA		Prot	NA		Split	NA		Split	NA	custom



Lanes, Volumes, Timings  
6: Conde Lane & Shiloh Road

2028 Opening Year No Project Conditions

Timing Plan: P.M. Peak

Lane Group	EBL	EBT	EBR	WBL	WBT	WBR	NBL	NBT	NBR	SBL	SBT	SBR
Protected Phases	5	2		1	6		7	7		4	4	
Permitted Phases												6
Detector Phase	5	2		1	6		7	7		4	4	6
Switch Phase												
Minimum Initial (s)	8.0	8.0		8.0	8.0		10.0	10.0		11.0	11.0	8.0
Minimum Split (s)	12.0	46.0		12.0	12.0		37.0	37.0		15.0	15.0	12.0
Total Split (s)	13.0	46.0		12.0	45.0		37.0	37.0		15.0	15.0	45.0
Total Split (%)	11.8%	41.8%		10.9%	40.9%		33.6%	33.6%		13.6%	13.6%	40.9%
Maximum Green (s)	9.0	42.0		8.0	41.0		33.0	33.0		11.0	11.0	41.0
Yellow Time (s)	3.0	3.0		3.0	3.0		3.0	3.0		3.0	3.0	3.0
All-Red Time (s)	1.0	1.0		1.0	1.0		1.0	1.0		1.0	1.0	1.0
Lost Time Adjust (s)	0.0	0.0		0.0	0.0		0.0	0.0		0.0	0.0	0.0
Total Lost Time (s)	4.0	4.0		4.0	4.0		4.0	4.0		4.0	4.0	4.0
Lead/Lag	Lead	Lag		Lead	Lag							Lag
Lead-Lag Optimize?	Yes	Yes		Yes	Yes							Yes
Vehicle Extension (s)	3.0	3.0		3.0	3.0		3.0	3.0		3.0	3.0	3.0
Recall Mode	None	None		None	None		None	None		None	None	None
Walk Time (s)		7.0					7.0	7.0				
Flash Don't Walk (s)		35.0					26.0	26.0				
Pedestrian Calls (#/hr)		0					0	0				
Act Effct Green (s)	9.6	34.6		9.1	27.1		11.4			12.5	27.1	
Actuated g/C Ratio	0.15	0.53		0.14	0.42		0.18			0.19	0.42	
v/c Ratio	0.34	0.32		0.04	0.72		0.14			1.12	0.08	
Control Delay (s/veh)	36.7	9.9		34.5	17.7		18.8			121.3	13.6	
Queue Delay	0.0	0.0		0.0	0.0		0.0			0.0	0.0	
Total Delay (s/veh)	36.7	9.9		34.5	17.7		18.8			121.3	13.6	
LOS	D	A		C	B		B			F	B	
Approach Delay (s/veh)		13.3			17.8		18.8			108.9		
Approach LOS		B			B		B			F		

Intersection Summary

















Area Type:	Other
Cycle Length:	110
Actuated Cycle Length:	64.9
Natural Cycle:	120
Control Type:	Actuated-Uncoordinated
Maximum v/c Ratio:	1.12
Intersection Signal Delay (s/veh):	34.0
Intersection LOS:	C
Intersection Capacity Utilization:	67.0%
ICU Level of Service:	C
Analysis Period (min):	15

Splits and Phases: 6: Conde Lane & Shiloh Road



Lanes, Volumes, Timings  
7: Entrance 1/Gridley Drive & Shiloh Road



















2028 Opening Year No Project Conditions  
Timing Plan: P.M. Peak

												
Lane Group	EBL	EBT	EBR	WBL	WBT	WBR	NBL	NBT	NBR	SBL	SBT	SBR
Lane Configurations												
Traffic Volume (vph)	19	117	0	0	142	0	0	0	0	0	0	16
Future Volume (vph)	19	117	0	0	142	0	0	0	0	0	0	16
Ideal Flow (vphpl)	1900	1900	1900	1900	1900	1900	1900	1900	1900	1900	1900	1900
Lane Util. Factor	1.00	1.00	1.00	1.00	1.00	1.00	1.00	1.00	1.00	1.00	1.00	1.00
Ped Bike Factor												
Frt												0.865
Flt Protected	0.993											
Satd. Flow (prot)	0	1850	0	0	1863	0	1863	1863	0	0	1611	0
Flt Permitted	0.993											
Satd. Flow (perm)	0	1850	0	0	1863	0	1863	1863	0	0	1611	0
Link Speed (mph)	40		40				30		30			
Link Distance (ft)	608		2146				248		715			
Travel Time (s)	10.4		36.6				5.6		16.3			
Confl. Peds. (#/hr)	1											
Confl. Bikes (#/hr)	1											
Peak Hour Factor	0.94	0.94	0.94	0.69	0.69	0.69	1.00	1.00	1.00	0.58	0.58	0.58
Adj. Flow (vph)	20	124	0	0	206	0	0	0	0	0	0	28
Shared Lane Traffic (%)												
Lane Group Flow (vph)	0	144	0	0	206	0	0	0	0	0	28	0
Enter Blocked Intersection	No	No	No	No	No	No	No	No	No	No	No	No
Lane Alignment	Left	Left	Right	Left	Left	Right	Left	Left	Right	Left	Left	Right
Median Width(ft)	0		0				12		12			
Link Offset(ft)	0		0				0		0			
Crosswalk Width(ft)	16		16				16		16			
Two way Left Turn Lane												
Headway Factor	1.00	1.00	1.00	1.00	1.00	1.00	1.00	1.00	1.00	1.00	1.00	1.00
Turning Speed (mph)	15		9		15		9		15		9	
Sign Control	Free		Free				Stop		Stop			
<b>Intersection Summary</b>												
Area Type:	Other											
Control Type:	Unsignalized											
Intersection Capacity Utilization	28.0%						ICU Level of Service A					
Analysis Period (min)	15											

Lanes, Volumes, Timings  
8: Old Redwood Hwy & Entrance 1

2028 Opening Year No Project Conditions

Timing Plan: P.M. Peak

												
Lane Group	EBL	EBT	EBR	WBL	WBT	WBR	NBL	NBT	NBR	SBL	SBT	SBR
Lane Configurations												
Traffic Volume (vph)	3	0	0	0	0	0	0	575	0	0	486	0
Future Volume (vph)	3	0	0	0	0	0	0	575	0	0	486	0
Ideal Flow (vphp)	1900	1900	1900	1900	1900	1900	1900	1900	1900	1900	1900	1900
Storage Length (ft)	0		0	0		0	0		0	50		0
Storage Lanes	0		0	1		0	0		0	1		0
Taper Length (ft)	25			25			25			25		
Lane Util. Factor	1.00	1.00	1.00	1.00	1.00	1.00	1.00	1.00	1.00	1.00	1.00	1.00
Ped Bike Factor												
Frts												
Flt Protected		0.950										
Satd. Flow (prot)	0	1770	0	1863	1863	0	0	1863	0	1863	1863	0
Flt Permitted		0.950										
Satd. Flow (perm)	0	1770	0	1863	1863	0	0	1863	0	1863	1863	0
Link Speed (mph)		30			30			45			45	
Link Distance (ft)		98			385			520			748	
Travel Time (s)		2.2			8.8			7.9			11.3	
Confl. Bikes (#/hr)									3			5
Peak Hour Factor	0.38	0.38	0.38	1.00	1.00	1.00	0.91	0.91	0.91	0.94	0.94	0.94
Adj. Flow (vph)	8	0	0	0	0	0	0	632	0	0	517	0
Shared Lane Traffic (%)												
Lane Group Flow (vph)	0	8	0	0	0	0	0	632	0	0	517	0
Enter Blocked Intersection	No	No	No	No	No	No	No	No	No	No	No	No
Lane Alignment	Left	Left	Right	Left	Left	Right	Left	Left	Right	Left	Left	Right
Median Width(ft)		12			12			12			12	
Link Offset(ft)		0			0			0			0	
Crosswalk Width(ft)		16			16			16			16	
Two way Left Turn Lane												
Headway Factor	1.00	1.00	1.00	1.00	1.00	1.00	1.00	1.00	1.00	1.00	1.00	1.00
Turning Speed (mph)	15		9	15		9	15		9	15		9
Sign Control		Stop			Stop			Free			Free	
<b>Intersection Summary</b>												
Area Type:	Other											
Control Type:	Unsignalized											
Intersection Capacity Utilization	40.3%						ICU Level of Service A					
Analysis Period (min)	15											

Lanes, Volumes, Timings  
9: Entrance 2 & Shiloh Road

2028 Opening Year No Project Conditions

Timing Plan: P.M. Peak

	→	↘	↙	←	↖	↗
Lane Group	EBT	EBR	WBL	WBT	NBL	NBR
Lane Configurations	↗			↖	↘	↗
Traffic Volume (vph)	92	0	0	126	0	0
Future Volume (vph)	92	0	0	126	0	0
Ideal Flow (vphpl)	1900	1900	1900	1900	1900	1900
Lane Util. Factor	1.00	1.00	1.00	1.00	1.00	1.00
<b>Fr</b>						
<b>Flt Protected</b>						
Satd. Flow (prot)	1863	0	0	1863	1863	1863
<b>Flt Permitted</b>						
Satd. Flow (perm)	1863	0	0	1863	1863	1863
Link Speed (mph)	40			40	30	
Link Distance (ft)	2146			134	402	
Travel Time (s)	36.6			2.3	9.1	
Peak Hour Factor	0.92	0.92	0.68	0.68	1.00	1.00
Adj. Flow (vph)	100	0	0	185	0	0
<b>Shared Lane Traffic (%)</b>						
Lane Group Flow (vph)	100	0	0	185	0	0
Enter Blocked Intersection	No	No	No	No	No	No
Lane Alignment	Left	Right	Left	Left	Left	Right
Median Width(ft)	0			0	12	
Link Offset(ft)	0			0	0	
Crosswalk Width(ft)	16			16	16	
<b>Two way Left Turn Lane</b>						
Headway Factor	1.00	1.00	1.00	1.00	1.00	1.00
Turning Speed (mph)		9	15		15	9
Sign Control	Free			Free	Stop	
<b>Intersection Summary</b>						
Area Type:	Other					
Control Type:	Unsignalized					
Intersection Capacity Utilization	10.0%			ICU Level of Service A		
Analysis Period (min)	15					

Lanes, Volumes, Timings

2028 Opening Year No Project Conditions

10: US 101 NB Off Ramp/Lakewood Drive & Old Redwood Highway

Timing Plan: P.M. Peak



Lane Group	EBL	EBT	EBR	WBL	WBT	WBR	NBL	NBT	NBR	SBL	SBT	SBR
Lane Configurations												
Traffic Volume (vph)	297	399	0	0	566	219	569	469	286	284	0	657
Future Volume (vph)	297	399	0	0	566	219	569	469	286	284	0	657
Ideal Flow (vphpl)	1900	1900	1900	1900	1900	1900	1900	1900	1900	1900	1900	1900
Storage Length (ft)	155		0	0		0	270		150	120		0
Storage Lanes	1		0	0		0	1		1	1		1
Taper Length (ft)	50			25			165			75		
Lane Util. Factor	0.97	1.00	1.00	1.00	0.95	0.95	0.91	0.91	0.95	0.97	1.00	1.00
Ped Bike Factor	1.00				0.99			0.99		1.00		
Flt					0.958			0.951				0.850
Flt Protected	0.950						0.950	0.993		0.950		
Satd. Flow (prot)	3433	1863	0	0	3370	0	1610	3181	0	3433	0	1583
Flt Permitted	0.950						0.950	0.993		0.950		
Satd. Flow (perm)	3427	1863	0	0	3370	0	1610	3181	0	3422	0	1583
Right Turn on Red			Yes			Yes			Yes			Yes
Satd. Flow (RTOR)					65			85				277
Link Speed (mph)		35			35			30				30
Link Distance (ft)		226			617			716				478
Travel Time (s)		4.4			12.0			16.3				10.9
Confl. Peds. (#/hr)	3		1	1		3			8	8		
Confl. Bikes (#/hr)			2			9						
Peak Hour Factor	0.87	0.87	0.87	0.91	0.91	0.91	0.92	0.92	0.92	0.96	0.96	0.96
Adj. Flow (vph)	341	459	0	0	622	241	618	510	311	296	0	684
Shared Lane Traffic (%)							22%					
Lane Group Flow (vph)	341	459	0	0	863	0	482	957	0	296	0	684
Enter Blocked Intersection	No	No	No	No	No	No	No	No	No	No	No	No
Lane Alignment	Left	Left	Right	Left	Left	Right	Left	Left	Right	Left	Left	Right
Median Width(ft)		24			24			24				24
Link Offset(ft)		0			0			0				0
Crosswalk Width(ft)		16			16			16				16
Two way Left Turn Lane												
Headway Factor	1.00	1.00	1.00	1.00	1.00	1.00	1.00	1.00	1.00	1.00	1.00	1.00
Turning Speed (mph)	15		9	15		9	15		9	15		9
Number of Detectors	1	2			2		1	2		1		1
Detector Template	Left	Thru			Thru		Left	Thru		Left		Right
Leading Detector (ft)	20	100			100		20	100		20		20
Trailing Detector (ft)	0	0			0		0	0		0		0
Detector 1 Position(ft)	0	0			0		0	0		0		0
Detector 1 Size(ft)	20	6			6		20	6		20		20
Detector 1 Type	Cl+Ex	Cl+Ex			Cl+Ex		Cl+Ex	Cl+Ex		Cl+Ex		Cl+Ex
Detector 1 Channel												
Detector 1 Extend (s)	0.0	0.0			0.0		0.0	0.0		0.0		0.0
Detector 1 Queue (s)	0.0	0.0			0.0		0.0	0.0		0.0		0.0
Detector 1 Delay (s)	0.0	0.0			0.0		0.0	0.0		0.0		0.0
Detector 2 Position(ft)		94			94			94				
Detector 2 Size(ft)		6			6			6				
Detector 2 Type		Cl+Ex			Cl+Ex			Cl+Ex				
Detector 2 Channel												
Detector 2 Extend (s)		0.0			0.0			0.0				

Lanes, Volumes, Timings

2028 Opening Year No Project Conditions

10: US 101 NB Off Ramp/Lakewood Drive & Old Redwood Highway

Timing Plan: P.M. Peak



Lane Group	EBL	EBT	EBR	WBL	WBT	WBR	NBL	NBT	NBR	SBL	SBT	SBR
Turn Type	Prot	NA			NA		Split	NA		Prot		pm+ov
Protected Phases	5	2			6		8	8		7		5
Permitted Phases												5 8
Detector Phase	5	2			6		8	8		7		5
Switch Phase												
Minimum Initial (s)	7.0	10.0			10.0		10.0	10.0		7.0		7.0
Minimum Split (s)	11.0	32.1			32.1		33.7	33.7		11.0		11.0
Total Split (s)	13.0	45.3			32.3		33.7	33.7		11.0		13.0
Total Split (%)	14.4%	50.3%			35.9%		37.4%	37.4%		12.2%		14.4%
Maximum Green (s)	9.0	40.2			27.2		29.0	29.0		7.0		9.0
Yellow Time (s)	3.0	4.1			4.1		3.7	3.7		3.0		3.0
All-Red Time (s)	1.0	1.0			1.0		1.0	1.0		1.0		1.0
Lost Time Adjust (s)	0.0	0.0			0.0		0.0	0.0		0.0		0.0
Total Lost Time (s)	4.0	5.1			5.1		4.7	4.7		4.0		4.0
Lead/Lag	Lead				Lag		Lag	Lag		Lead		Lead
Lead-Lag Optimize?	Yes				Yes		Yes	Yes		Yes		Yes
Vehicle Extension (s)	3.0	3.0			3.0		3.0	3.0		3.0		3.0
Recall Mode	None	Max			Max		None	None		None		None
Walk Time (s)		7.0			7.0		7.0	7.0				
Flash Don't Walk (s)		20.0			17.0		22.0	22.0				
Pedestrian Calls (#/hr)		0			0		0	0				
Act Effct Green (s)	9.0	40.2			27.2		29.0	29.0		7.0		42.7
Actuated g/C Ratio	0.10	0.45			0.30		0.32	0.32		0.08		0.47
v/c Ratio	0.99	0.55			0.81		0.93	0.88		1.11		0.76
Control Delay (s/veh)	89.6	21.4			34.1		56.9	37.7		127.8		17.8
Queue Delay	0.0	0.0			0.0		0.0	0.0		0.0		0.0
Total Delay (s/veh)	89.6	21.4			34.1		56.9	37.7		127.8		17.8
LOS	F	C			C		E	D		F		B
Approach Delay (s/veh)		50.5			34.1			44.1				51.0
Approach LOS		D			C			D				D

Intersection Summary

Area Type: Other  
 Cycle Length: 90  
 Actuated Cycle Length: 90  
 Natural Cycle: 90  
 Control Type: Actuated-Uncoordinated  
 Maximum v/c Ratio: 1.11  
 Intersection Signal Delay (s/veh): 44.9  
 Intersection LOS: D  
 Intersection Capacity Utilization 100.9%  
 ICU Level of Service G  
 Analysis Period (min) 15

Splits and Phases: 10: US 101 NB Off Ramp/Lakewood Drive & Old Redwood Highway

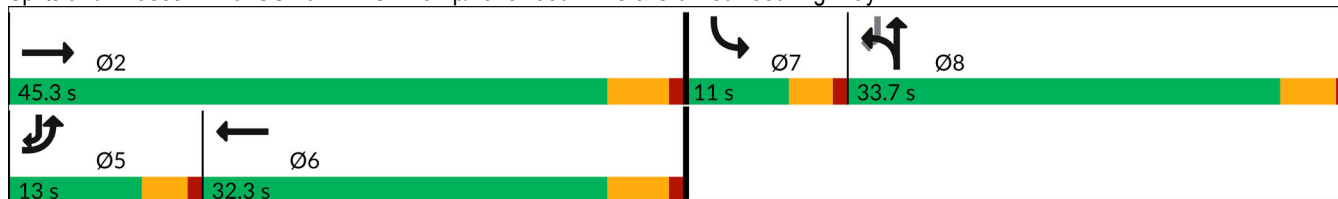

Lanes, Volumes, Timings  
 11: Old Redwood Highway & US 101 NB On Ramp

2028 Opening Year No Project Conditions

Timing Plan: P.M. Peak

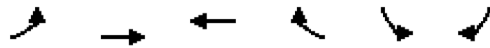

Lane Group	EBL	EBT	WBT	WBR	SBL	SBR
Lane Configurations	↶	↷↷	↶↷			
Traffic Volume (vph)	121	689	1598	192	0	0
Future Volume (vph)	121	689	1598	192	0	0
Ideal Flow (vphp)	1900	1900	1900	1900	1900	1900
Storage Length (ft)	245			0	0	0
Storage Lanes	1			0	0	0
Taper Length (ft)	50				25	
Lane Util. Factor	1.00	0.95	0.95	0.95	1.00	1.00
Ped Bike Factor						
Frt			0.984			
Flt Protected	0.950					
Satd. Flow (prot)	1770	3539	3483	0	0	0
Flt Permitted	0.950					
Satd. Flow (perm)	1770	3539	3483	0	0	0
Link Speed (mph)		35	35		30	
Link Distance (ft)		531	226		299	
Travel Time (s)		10.3	4.4		6.8	
Confl. Peds. (#/hr)	17			17		
Confl. Bikes (#/hr)				8		
Peak Hour Factor	0.85	0.85	0.91	0.91	0.25	0.25
Adj. Flow (vph)	142	811	1756	211	0	0
Shared Lane Traffic (%)						
Lane Group Flow (vph)	142	811	1967	0	0	0
Enter Blocked Intersection	No	No	No	No	No	No
Lane Alignment	Left	Left	Left	Right	Left	Right
Median Width(ft)		12	12		0	
Link Offset(ft)		0	0		0	
Crosswalk Width(ft)		16	16		16	
Two way Left Turn Lane						
Headway Factor	1.00	1.00	1.00	1.00	1.00	1.00
Turning Speed (mph)	15			9	15	9
Sign Control		Free	Free		Free	

Intersection Summary

Area Type:	Other
Control Type:	Unsignalized
Intersection Capacity Utilization	72.4%
Analysis Period (min)	15
	ICU Level of Service C

Lanes, Volumes, Timings

2028 Opening Year No Project Conditions

12: US 101 SB On Ramp/US 101 SB Off Ramp & Old Redwood Highway

Timing Plan: P.M. Peak



Lane Group	EBL	EBT	EBR	WBL	WBT	WBR	NBL	NBT	NBR	SBL	SBT	SBR
Lane Configurations		↑↑	↗	↘	↑↑					↘	↕	
Traffic Volume (vph)	0	609	434	434	1166	0	0	0	0	190	0	147
Future Volume (vph)	0	609	434	434	1166	0	0	0	0	190	0	147
Ideal Flow (vphpl)	1900	1900	1900	1900	1900	1900	1900	1900	1900	1900	1900	1900
Storage Length (ft)	0		0	250		0	0		0	420		0
Storage Lanes	0		1	0		0	0		0	1		0
Taper Length (ft)	25			165			25			75		
Lane Util. Factor	1.00	0.95	1.00	1.00	0.95	1.00	1.00	1.00	1.00	0.95	0.95	1.00
Ped Bike Factor			0.98	1.00								
Frt			0.850								0.867	
Flt Protected				0.950						0.950	0.994	
Satd. Flow (prot)	0	3539	1583	1770	3539	0	0	0	0	1681	1525	0
Flt Permitted				0.950						0.950	0.994	
Satd. Flow (perm)	0	3539	1558	1768	3539	0	0	0	0	1681	1525	0
Right Turn on Red			Yes			Yes			Yes			Yes
Satd. Flow (RTOR)			453								95	
Link Speed (mph)		35			35			30			30	
Link Distance (ft)		423			531			621			831	
Travel Time (s)		8.2			10.3			14.1			18.9	
Confl. Peds. (#/hr)	19		2	2		18						
Confl. Bikes (#/hr)			4			2						
Peak Hour Factor	0.94	0.94	0.94	0.89	0.89	0.89	0.25	0.25	0.25	0.83	0.83	0.83
Adj. Flow (vph)	0	648	462	488	1310	0	0	0	0	229	0	177
Shared Lane Traffic (%)										10%		
Lane Group Flow (vph)	0	648	462	488	1310	0	0	0	0	206	200	0
Enter Blocked Intersection	No	No	No	No	No	No	No	No	No	No	No	No
Lane Alignment	Left	Left	Right	Left	Left	Right	Left	Left	Right	Left	Left	Right
Median Width(ft)		24			24			12			12	
Link Offset(ft)		0			0			0			0	
Crosswalk Width(ft)		16			16			16			16	
Two way Left Turn Lane												
Headway Factor	1.00	1.00	1.00	1.00	1.00	1.00	1.00	1.00	1.00	1.00	1.00	1.00
Turning Speed (mph)	15		9	15		9	15		9	15		9
Number of Detectors		2	1	1	2					1	2	
Detector Template		Thru	Right	Left	Thru					Left	Thru	
Leading Detector (ft)		100	20	20	100					20	100	
Trailing Detector (ft)		0	0	0	0					0	0	
Detector 1 Position(ft)		0	0	0	0					0	0	
Detector 1 Size(ft)		6	20	20	6					20	6	
Detector 1 Type		Cl+Ex	Cl+Ex	Cl+Ex	Cl+Ex					Cl+Ex	Cl+Ex	
Detector 1 Channel												
Detector 1 Extend (s)		0.0	0.0	0.0	0.0					0.0	0.0	
Detector 1 Queue (s)		0.0	0.0	0.0	0.0					0.0	0.0	
Detector 1 Delay (s)		0.0	0.0	0.0	0.0					0.0	0.0	
Detector 2 Position(ft)		94			94							94
Detector 2 Size(ft)		6			6							6
Detector 2 Type		Cl+Ex			Cl+Ex							Cl+Ex
Detector 2 Channel												
Detector 2 Extend (s)		0.0			0.0							0.0



Lanes, Volumes, Timings

2028 Opening Year No Project Conditions

12: US 101 SB On Ramp/US 101 SB Off Ramp & Old Redwood Highway

Timing Plan: P.M. Peak



Lane Group	EBL	EBT	EBR	WBL	WBT	WBR	NBL	NBT	NBR	SBL	SBT	SBR
Turn Type		NA	Perm	Prot	NA					Perm	NA	
Protected Phases		6		5	2						8	
Permitted Phases			6							8		
Detector Phase		6	6	5	2					8	8	
Switch Phase												
Minimum Initial (s)		10.0	10.0	7.0	10.0					10.0	10.0	
Minimum Split (s)		32.1	32.1	11.0	38.1					14.7	14.7	
Total Split (s)		33.0	33.0	22.0	55.0					15.0	15.0	
Total Split (%)		47.1%	47.1%	31.4%	78.6%					21.4%	21.4%	
Maximum Green (s)		27.9	27.9	18.0	49.9					10.3	10.3	
Yellow Time (s)		4.1	4.1	3.0	4.1					3.7	3.7	
All-Red Time (s)		1.0	1.0	1.0	1.0					1.0	1.0	
Lost Time Adjust (s)		0.0	0.0	0.0	0.0					0.0	0.0	
Total Lost Time (s)		5.1	5.1	4.0	5.1					4.7	4.7	
Lead/Lag		Lag	Lag	Lead								
Lead-Lag Optimize?		Yes	Yes	Yes								
Vehicle Extension (s)		3.0	3.0	3.0	3.0					3.0	3.0	
Recall Mode		Max	Max	None	Max					None	None	
Walk Time (s)		7.0	7.0		7.0							
Flash Don't Walk (s)		20.0	20.0		25.0							
Pedestrian Calls (#/hr)		0	0		0							
Act Effct Green (s)		27.9	27.9	18.0	49.9					10.2	10.2	
Actuated g/C Ratio		0.40	0.40	0.26	0.71					0.15	0.15	
v/c Ratio		0.46	0.52	1.07	0.52					0.84	0.66	
Control Delay (s/veh)		16.8	4.1	91.4	5.5					59.7	27.2	
Queue Delay		0.0	0.0	0.0	0.0					0.0	0.0	
Total Delay (s/veh)		16.8	4.1	91.4	5.5					59.7	27.2	
LOS		B	A	F	A					E	C	
Approach Delay (s/veh)		11.5			28.8						43.7	
Approach LOS		B			C						D	

Intersection Summary

Area Type: Other  
 Cycle Length: 70  
 Actuated Cycle Length: 69.9  
 Natural Cycle: 80  
 Control Type: Actuated-Uncoordinated  
 Maximum v/c Ratio: 1.07  
 Intersection Signal Delay (s/veh): 24.8  
 Intersection LOS: C  
 Intersection Capacity Utilization 72.4%  
 ICU Level of Service C  
 Analysis Period (min) 15



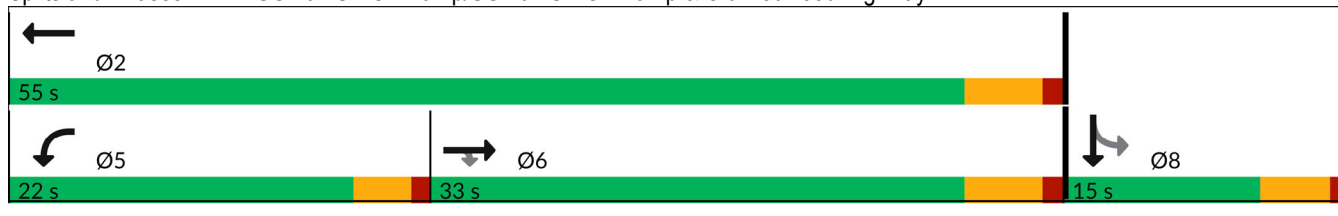



















Splits and Phases: 12: US 101 SB On Ramp/US 101 SB Off Ramp & Old Redwood Highway



Lanes, Volumes, Timings  
 1: Old Redwood Hwy & Shiloh Road

2028 Opening Year No Project Conditions

Timing Plan: Saturday Midday Peak

												
Lane Group	EBL	EBT	EBR	WBL	WBT	WBR	NBL	NBT	NBR	SBL	SBT	SBR
Lane Configurations												
Traffic Volume (vph)	156	83	197	24	83	17	200	266	27	23	216	239
Future Volume (vph)	156	83	197	24	83	17	200	266	27	23	216	239
Ideal Flow (vphpl)	1900	1900	1900	1900	1900	1900	1900	1900	1900	1900	1900	1900
Storage Length (ft)	375		140	0		50	200		98	130		93
Storage Lanes	1		1	0		1	1		1	1		1
Taper Length (ft)	50			25			60			93		
Lane Util. Factor	1.00	1.00	1.00	1.00	1.00	1.00	1.00	1.00	1.00	1.00	1.00	1.00
Ped Bike Factor	0.99		0.98						0.98			0.97
Frt			0.850			0.850			0.850			0.850
Flt Protected	0.950				0.989		0.950			0.950		
Satd. Flow (prot)	1770	1863	1583	0	1842	1583	1770	1863	1583	1770	1863	1583
Flt Permitted	0.950				0.989		0.950			0.950		
Satd. Flow (perm)	1759	1863	1549	0	1842	1583	1770	1863	1550	1770	1863	1540
Right Turn on Red			Yes			Yes			Yes			Yes
Satd. Flow (RTOR)			221			113			81			189
Link Speed (mph)		40			40			45			40	
Link Distance (ft)		1789			608			748			775	
Travel Time (s)		30.5			10.4			11.3			13.2	
Confl. Peds. (#/hr)	4											
Confl. Bikes (#/hr)			1						1			5
Peak Hour Factor	0.89	0.89	0.89	0.86	0.86	0.86	0.93	0.93	0.93	0.91	0.91	0.91
Adj. Flow (vph)	175	93	221	28	97	20	215	286	29	25	237	263
Shared Lane Traffic (%)												
Lane Group Flow (vph)	175	93	221	0	125	20	215	286	29	25	237	263
Enter Blocked Intersection	No	No	No	No	No	No	No	No	No	No	No	No
Lane Alignment	Left	Left	Right	Left	Left	Right	Left	Left	Right	Left	Left	Right
Median Width(ft)		12			12			12			12	
Link Offset(ft)		0			0			0			0	
Crosswalk Width(ft)		16			16			16			16	
Two way Left Turn Lane												
Headway Factor	1.00	1.00	1.00	1.00	1.00	1.00	1.00	1.00	1.00	1.00	1.00	1.00
Turning Speed (mph)	15		9	15		9	15		9	15		9
Number of Detectors	1	2	1	1	2	1	1	2	1	1	2	1
Detector Template	Left	Thru	Right	Left	Thru	Right	Left	Thru	Right	Left	Thru	Right
Leading Detector (ft)	20	100	20	20	100	20	20	100	20	20	100	20
Trailing Detector (ft)	0	0	0	0	0	0	0	0	0	0	0	0
Detector 1 Position(ft)	0	0	0	0	0	0	0	0	0	0	0	0
Detector 1 Size(ft)	20	6	20	20	6	20	20	6	20	20	6	20
Detector 1 Type	Cl+Ex	Cl+Ex	Cl+Ex	Cl+Ex	Cl+Ex	Cl+Ex	Cl+Ex	Cl+Ex	Cl+Ex	Cl+Ex	Cl+Ex	Cl+Ex
Detector 1 Channel												
Detector 1 Extend (s)	0.0	0.0	0.0	0.0	0.0	0.0	0.0	0.0	0.0	0.0	0.0	0.0
Detector 1 Queue (s)	0.0	0.0	0.0	0.0	0.0	0.0	0.0	0.0	0.0	0.0	0.0	0.0
Detector 1 Delay (s)	0.0	0.0	0.0	0.0	0.0	0.0	0.0	0.0	0.0	0.0	0.0	0.0
Detector 2 Position(ft)		94			94			94			94	
Detector 2 Size(ft)		6			6			6			6	
Detector 2 Type		Cl+Ex			Cl+Ex			Cl+Ex			Cl+Ex	
Detector 2 Channel												
Detector 2 Extend (s)		0.0			0.0			0.0			0.0	

Lanes, Volumes, Timings  
1: Old Redwood Hwy & Shiloh Road

2028 Opening Year No Project Conditions

Timing Plan: Saturday Midday Peak

Lane Group	EBL	EBT	EBR	WBL	WBT	WBR	NBL	NBT	NBR	SBL	SBT	SBR
Turn Type	Split	NA	Perm	Split	NA	Perm	Prot	NA	Perm	Prot	NA	Perm
Protected Phases	2	2		6	6		3	8		7	4	
Permitted Phases			2			6			8			4
Detector Phase	2	2	2	6	6	6	3	8	8	7	4	4
Switch Phase												
Minimum Initial (s)	5.0	5.0	5.0	5.0	5.0	5.0	5.0	5.0	5.0	5.0	5.0	5.0
Minimum Split (s)	34.5	34.5	34.5	42.5	42.5	42.5	9.0	46.5	46.5	9.0	39.5	39.5
Total Split (s)	35.0	35.0	35.0	42.5	42.5	42.5	18.0	48.0	48.0	9.5	39.5	39.5
Total Split (%)	25.9%	25.9%	25.9%	31.5%	31.5%	31.5%	13.3%	35.6%	35.6%	7.0%	29.3%	29.3%
Maximum Green (s)	30.5	30.5	30.5	38.0	38.0	38.0	14.0	43.5	43.5	5.5	35.0	35.0
Yellow Time (s)	3.5	3.5	3.5	3.5	3.5	3.5	3.5	3.5	3.5	3.5	3.5	3.5
All-Red Time (s)	1.0	1.0	1.0	1.0	1.0	1.0	0.5	1.0	1.0	0.5	1.0	1.0
Lost Time Adjust (s)	0.0	0.0	0.0		0.0	0.0	0.0	0.0	0.0	0.0	0.0	0.0
Total Lost Time (s)	4.5	4.5	4.5		4.5	4.5	4.0	4.5	4.5	4.0	4.5	4.5
Lead/Lag	Lead	Lead	Lead	Lag	Lag	Lag	Lead	Lag	Lag	Lead	Lag	Lag
Lead-Lag Optimize?	Yes	Yes	Yes	Yes	Yes	Yes	Yes	Yes	Yes	Yes	Yes	Yes
Vehicle Extension (s)	3.0	3.0	3.0	3.0	3.0	3.0	3.0	3.0	3.0	3.0	3.0	3.0
Recall Mode	None	None	None	None	None	None	None	None	None	None	None	None
Walk Time (s)	7.0	7.0	7.0	7.0	7.0	7.0		7.0	7.0		7.0	7.0
Flash Don't Walk (s)	23.0	23.0	23.0	31.0	31.0	31.0		35.0	35.0		28.0	28.0
Pedestrian Calls (#/hr)	0	0	0	0	0	0		0	0		0	0
Act Effct Green (s)	13.6	13.6	13.6		11.0	11.0	14.4	30.8	30.8	5.7	15.5	15.5
Actuated g/C Ratio	0.19	0.19	0.19		0.15	0.15	0.20	0.42	0.42	0.08	0.21	0.21
v/c Ratio	0.53	0.27	0.47		0.45	0.06	0.61	0.36	0.04	0.18	0.60	0.55
Control Delay (s/veh)	34.1	29.0	8.0		35.9	0.4	39.3	18.9	0.1	40.4	33.6	13.5
Queue Delay	0.0	0.0	0.0		0.0	0.0	0.0	0.0	0.0	0.0	0.0	0.0
Total Delay (s/veh)	34.1	29.0	8.0		35.9	0.4	39.3	18.9	0.1	40.4	33.6	13.5
LOS	C	C	A		D	A	D	B	A	D	C	B
Approach Delay (s/veh)		21.3			31.0			26.2			23.9	
Approach LOS		C			C			C			C	

Intersection Summary





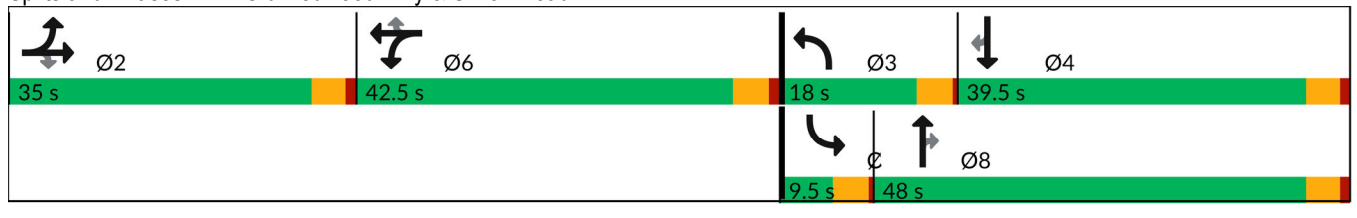



















Area Type: Other  
 Cycle Length: 135  
 Actuated Cycle Length: 72.5  
 Natural Cycle: 135  
 Control Type: Actuated-Uncoordinated  
 Maximum v/c Ratio: 0.61  
 Intersection Signal Delay (s/veh): 24.5  
 Intersection LOS: C  
 Intersection Capacity Utilization 48.6%  
 ICU Level of Service A  
 Analysis Period (min) 15

Splits and Phases: 1: Old Redwood Hwy & Shiloh Road



Lanes, Volumes, Timings  
 2: Shiloh Road & Hembree Ln













2028 Opening Year No Project Conditions  
 Timing Plan: Saturday Midday Peak

												
Lane Group	EBL	EBT	EBR	WBL	WBT	WBR	NBL	NBT	NBR	SBL	SBT	SBR
Lane Configurations	 			 	 						 	
Traffic Volume (vph)	708	359	44	24	279	185	65	11	15	182	11	666
Future Volume (vph)	708	359	44	24	279	185	65	11	15	182	11	666
Ideal Flow (vphpl)	1900	1900	1900	1900	1900	1900	1900	1900	1900	1900	1900	1900
Storage Length (ft)	0		0	100		130	0		0	0		0
Storage Lanes	2		0	1		1	1		0	0		1
Taper Length (ft)	25			50			25			25		
Lane Util. Factor	0.97	1.00	1.00	1.00	0.95	0.95	1.00	1.00	1.00	1.00	1.00	1.00
Ped Bike Factor	1.00				0.99							
Frt		0.985			0.940			0.913				0.850
Flt Protected	0.950			0.950			0.950				0.955	
Satd. Flow (prot)	3433	1835	0	1770	3310	0	1770	1701	0	0	1779	1583
Flt Permitted	0.950			0.950			0.950				0.955	
Satd. Flow (perm)	3431	1835	0	1770	3310	0	1770	1701	0	0	1779	1583
Right Turn on Red			Yes			Yes			Yes			Yes
Satd. Flow (RTOR)		11			193			15				458
Link Speed (mph)		40			40			30				35
Link Distance (ft)		302			1789			216				381
Travel Time (s)		5.1			30.5			4.9				7.4
Confl. Peds. (#/hr)	1						1					
Peak Hour Factor	0.94	0.94	1.00	1.00	0.96	0.96	1.00	1.00	1.00	0.91	1.00	0.91
Adj. Flow (vph)	753	382	44	24	291	193	65	11	15	200	11	732
Shared Lane Traffic (%)												
Lane Group Flow (vph)	753	426	0	24	484	0	65	26	0	0	211	732
Enter Blocked Intersection	No	No	No	No	No	No	No	No	No	No	No	No
Lane Alignment	Left	Left	Right	Left	Left	Right	Left	Left	Right	Left	Left	Right
Median Width(ft)		24			24			12				12
Link Offset(ft)		0			0			0				0
Crosswalk Width(ft)		16			16			16				16
Two way Left Turn Lane												
Headway Factor	1.00	1.00	1.00	1.00	1.00	1.00	1.00	1.00	1.00	1.00	1.00	1.00
Turning Speed (mph)	15		9	15		9	15		9	15		9
Number of Detectors	1	2		1	2		1	2		1	2	1
Detector Template	Left	Thru		Left	Thru		Left	Thru		Left	Thru	Right
Leading Detector (ft)	20	100		20	100		20	100		20	100	20
Trailing Detector (ft)	0	0		0	0		0	0		0	0	0
Detector 1 Position(ft)	0	0		0	0		0	0		0	0	0
Detector 1 Size(ft)	20	6		20	6		20	6		20	6	20
Detector 1 Type	Cl+Ex	Cl+Ex		Cl+Ex	Cl+Ex		Cl+Ex	Cl+Ex		Cl+Ex	Cl+Ex	Cl+Ex
Detector 1 Channel												
Detector 1 Extend (s)	0.0	0.0		0.0	0.0		0.0	0.0		0.0	0.0	0.0
Detector 1 Queue (s)	0.0	0.0		0.0	0.0		0.0	0.0		0.0	0.0	0.0
Detector 1 Delay (s)	0.0	0.0		0.0	0.0		0.0	0.0		0.0	0.0	0.0
Detector 2 Position(ft)		94			94			94				94
Detector 2 Size(ft)		6			6			6				6
Detector 2 Type		Cl+Ex			Cl+Ex			Cl+Ex				Cl+Ex
Detector 2 Channel												
Detector 2 Extend (s)		0.0			0.0			0.0				0.0
Turn Type	Prot	NA		Prot	NA		Split	NA		Split	NA	pt+ov

Lanes, Volumes, Timings  
2: Shiloh Road & Hembree Ln

2028 Opening Year No Project Conditions

Timing Plan: Saturday Midday Peak

												
Lane Group	EBL	EBT	EBR	WBL	WBT	WBR	NBL	NBT	NBR	SBL	SBT	SBR
Protected Phases	5	2		1	6		8	8		4	4	4 5
Permitted Phases												
Detector Phase	5	2		1	6		8	8		4	4	4 5
Switch Phase												
Minimum Initial (s)	3.0	5.0		5.0	5.0		5.0	5.0		5.0	5.0	
Minimum Split (s)	7.5	9.5		9.5	43.5		9.5	9.5		9.5	9.5	
Total Split (s)	21.0	57.0		9.5	45.5		9.5	9.5		14.0	14.0	
Total Split (%)	23.3%	63.3%		10.6%	50.6%		10.6%	10.6%		15.6%	15.6%	
Maximum Green (s)	17.0	53.0		5.5	41.5		5.5	5.5		10.0	10.0	
Yellow Time (s)	3.0	3.0		3.0	3.0		3.0	3.0		3.0	3.0	
All-Red Time (s)	1.0	1.0		1.0	1.0		1.0	1.0		1.0	1.0	
Lost Time Adjust (s)	0.0	0.0		0.0	0.0		0.0	0.0		0.0	0.0	
Total Lost Time (s)	4.0	4.0		4.0	4.0		4.0	4.0		4.0	4.0	
Lead/Lag	Lead	Lag		Lead	Lag							
Lead-Lag Optimize?	Yes	Yes		Yes	Yes							
Vehicle Extension (s)	3.0	3.0		3.0	3.0		3.0	3.0		3.0	3.0	
Recall Mode	None	None		None	None		None	None		None	None	
Walk Time (s)					7.0							
Flash Don't Walk (s)					32.0							
Pedestrian Calls (#/hr)					1							
Act Effct Green (s)	17.7	34.9		5.7	14.4		5.7	5.7		10.4	29.2	
Actuated g/C Ratio	0.28	0.56		0.09	0.23		0.09	0.09		0.17	0.47	
v/c Ratio	0.77	0.41		0.15	0.53		0.40	0.15		0.71	0.74	
Control Delay (s/veh)	30.8	9.8		34.2	13.8		40.4	23.8		44.5	11.6	
Queue Delay	0.0	0.0		0.0	0.0		0.0	0.0		0.0	0.0	
Total Delay (s/veh)	30.8	9.8		34.2	13.8		40.4	23.8		44.5	11.6	
LOS	C	A		C	B		D	C		D	B	
Approach Delay (s/veh)		23.2			14.7			35.7			18.9	
Approach LOS		C			B			D			B	

Intersection Summary

Area Type:	Other
Cycle Length:	90
Actuated Cycle Length:	62.4
Natural Cycle:	90
Control Type:	Actuated-Uncoordinated
Maximum v/c Ratio:	0.77
Intersection Signal Delay (s/veh):	20.6
Intersection LOS:	C
Intersection Capacity Utilization:	69.7%
ICU Level of Service:	C
Analysis Period (min):	15

Splits and Phases: 2: Shiloh Road & Hembree Ln



Lanes, Volumes, Timings  
3: US 101 NB Off-Ramp & Shiloh Road

2028 Opening Year No Project Conditions  
Timing Plan: Saturday Midday Peak

	→	↘	↙	←	↖	↗
Lane Group	EBT	EBR	WBL	WBT	NBL	NBR
Lane Configurations	↑↑			↑	↘	↗
Traffic Volume (vph)	442	0	0	773	401	658
Future Volume (vph)	442	0	0	773	401	658
Ideal Flow (vphpl)	1900	1900	1900	1900	1900	1900
Storage Length (ft)		0	0		0	265
Storage Lanes		0	0		1	2
Taper Length (ft)			25		25	
Lane Util. Factor	0.95	1.00	1.00	1.00	1.00	0.88
Ped Bike Factor						
Frt						0.850
Flt Protected					0.950	
Satd. Flow (prot)	3539	0	0	1863	1770	2787
Flt Permitted					0.950	
Satd. Flow (perm)	3539	0	0	1863	1770	2787
Right Turn on Red		Yes				Yes
Satd. Flow (RTOR)						473
Link Speed (mph)	40			40	30	
Link Distance (ft)	186			371	769	
Travel Time (s)	3.2			6.3	17.5	
Confl. Bikes (#/hr)		1				
Peak Hour Factor	0.91	0.91	0.89	0.89	0.95	0.95
Adj. Flow (vph)	486	0	0	869	422	693
Shared Lane Traffic (%)						
Lane Group Flow (vph)	486	0	0	869	422	693
Enter Blocked Intersection	No	No	No	No	No	No
Lane Alignment	Left	Right	Left	Left	Left	Right
Median Width(ft)	0			0	12	
Link Offset(ft)	0			0	0	
Crosswalk Width(ft)	16			16	16	
Two way Left Turn Lane						
Headway Factor	1.00	1.00	1.00	1.00	1.00	1.00
Turning Speed (mph)		9	15		15	9
Number of Detectors	2			2	1	1
Detector Template	Thru			Thru	Left	Right
Leading Detector (ft)	100			100	20	20
Trailing Detector (ft)	0			0	0	0
Detector 1 Position(ft)	0			0	0	0
Detector 1 Size(ft)	6			6	20	20
Detector 1 Type	Cl+Ex			Cl+Ex	Cl+Ex	Cl+Ex
Detector 1 Channel						
Detector 1 Extend (s)	0.0			0.0	0.0	0.0
Detector 1 Queue (s)	0.0			0.0	0.0	0.0
Detector 1 Delay (s)	0.0			0.0	0.0	0.0
Detector 2 Position(ft)	94			94		
Detector 2 Size(ft)	6			6		
Detector 2 Type	Cl+Ex			Cl+Ex		
Detector 2 Channel						
Detector 2 Extend (s)	0.0			0.0		
Turn Type	NA			NA	Prot	Perm

Lanes, Volumes, Timings  
 3: US 101 NB Off-Ramp & Shiloh Road

2028 Opening Year No Project Conditions  
 Timing Plan: Saturday Midday Peak

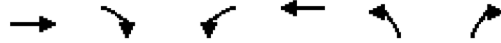

Lane Group	EBT	EBR	WBL	WBT	NBL	NBR
Protected Phases	2			6	8	
Permitted Phases						8
Detector Phase	2			6	8	8
Switch Phase						
Minimum Initial (s)	5.0			5.0	5.0	5.0
Minimum Split (s)	9.5			9.5	9.5	9.5
Total Split (s)	37.0			37.0	35.0	35.0
Total Split (%)	51.4%			51.4%	48.6%	48.6%
Maximum Green (s)	32.5			32.5	30.5	30.5
Yellow Time (s)	3.5			3.5	3.5	3.5
All-Red Time (s)	1.0			1.0	1.0	1.0
Lost Time Adjust (s)	0.0			0.0	0.0	0.0
Total Lost Time (s)	4.5			4.5	4.5	4.5
Lead/Lag						
Lead-Lag Optimize?						
Vehicle Extension (s)	3.0			3.0	3.0	3.0
Recall Mode	None			None	None	None
Act Effct Green (s)	32.8			32.8	20.9	20.9
Actuated g/C Ratio	0.52			0.52	0.33	0.33
v/c Ratio	0.26			0.89	0.72	0.56
Control Delay (s/veh)	10.0			30.3	25.4	6.7
Queue Delay	0.0			0.0	0.0	0.0
Total Delay (s/veh)	10.0			30.3	25.4	6.7
LOS	B			C	C	A
Approach Delay (s/veh)	10.0			30.3	13.8	
Approach LOS	B			C	B	

Intersection Summary

Area Type: Other  
 Cycle Length: 72  
 Actuated Cycle Length: 62.8  
 Natural Cycle: 60  
 Control Type: Actuated-Uncoordinated  
 Maximum v/c Ratio: 0.89  
 Intersection Signal Delay (s/veh): 18.8  
 Intersection LOS: B  
 Intersection Capacity Utilization 102.9%  
 ICU Level of Service G  
 Analysis Period (min) 15

Splits and Phases: 3: US 101 NB Off-Ramp & Shiloh Road

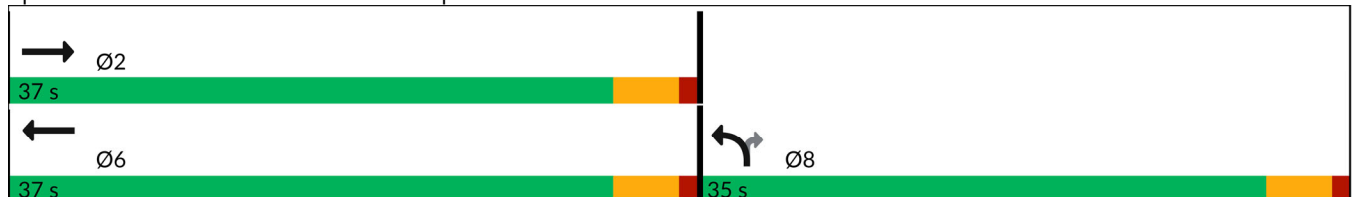

Lanes, Volumes, Timings  
4: Shiloh Road & US 101 SB Off-Ramp

2028 Opening Year No Project Conditions

Timing Plan: Saturday Midday Peak

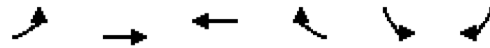

Lane Group	EBL	EBT	WBT	WBR	SBL	SBR
Lane Configurations		↑	↑		↘	↗
Traffic Volume (vph)	0	318	600	0	212	174
Future Volume (vph)	0	318	600	0	212	174
Ideal Flow (vphp)	1900	1900	1900	1900	1900	1900
Storage Length (ft)	0			0	0	275
Storage Lanes	0			0	1	1
Taper Length (ft)	25				25	
Lane Util. Factor	1.00	1.00	1.00	1.00	1.00	1.00
Ped Bike Factor						
Frt						0.850
Flt Protected					0.950	
Satd. Flow (prot)	0	1863	1863	0	1770	1583
Flt Permitted					0.950	
Satd. Flow (perm)	0	1863	1863	0	1770	1583
Right Turn on Red				Yes		Yes
Satd. Flow (RTOR)						256
Link Speed (mph)		40	40		30	
Link Distance (ft)		225	306		486	
Travel Time (s)		3.8	5.2		11.0	
Confl. Bikes (#/hr)				2		
Peak Hour Factor	0.96	0.96	0.96	0.96	0.68	0.68
Adj. Flow (vph)	0	331	625	0	312	256
Shared Lane Traffic (%)						
Lane Group Flow (vph)	0	331	625	0	312	256
Enter Blocked Intersection	No	No	No	No	No	No
Lane Alignment	Left	Left	Left	Right	Left	Right
Median Width(ft)		4	0		12	
Link Offset(ft)		0	0		0	
Crosswalk Width(ft)		16	16		16	
Two way Left Turn Lane						
Headway Factor	1.00	1.00	1.00	1.00	1.00	1.00
Turning Speed (mph)	15			9	15	9
Number of Detectors		2	2		1	1
Detector Template		Thru	Thru		Left	Right
Leading Detector (ft)		100	100		20	20
Trailing Detector (ft)		0	0		0	0
Detector 1 Position(ft)		0	0		0	0
Detector 1 Size(ft)		6	6		20	20
Detector 1 Type		Cl+Ex	Cl+Ex		Cl+Ex	Cl+Ex
Detector 1 Channel						
Detector 1 Extend (s)		0.0	0.0		0.0	0.0
Detector 1 Queue (s)		0.0	0.0		0.0	0.0
Detector 1 Delay (s)		0.0	0.0		0.0	0.0
Detector 2 Position(ft)		94	94			
Detector 2 Size(ft)		6	6			
Detector 2 Type		Cl+Ex	Cl+Ex			
Detector 2 Channel						
Detector 2 Extend (s)		0.0	0.0			
Turn Type		NA	NA		Perm	Perm



Lanes, Volumes, Timings  
4: Shiloh Road & US 101 SB Off-Ramp

2028 Opening Year No Project Conditions  
Timing Plan: Saturday Midday Peak



Lane Group	EBL	EBT	WBT	WBR	SBL	SBR
Protected Phases		2	6			
Permitted Phases					4	4
Detector Phase		2	6		4	4
Switch Phase						
Minimum Initial (s)		5.0	5.0		5.0	5.0
Minimum Split (s)		9.5	38.5		9.5	9.5
Total Split (s)		69.0	69.0		21.0	21.0
Total Split (%)		76.7%	76.7%		23.3%	23.3%
Maximum Green (s)		64.5	64.5		16.5	16.5
Yellow Time (s)		3.5	3.5		3.5	3.5
All-Red Time (s)		1.0	1.0		1.0	1.0
Lost Time Adjust (s)		0.0	0.0		0.0	0.0
Total Lost Time (s)		4.5	4.5		4.5	4.5
Lead/Lag						
Lead-Lag Optimize?						
Vehicle Extension (s)		3.0	3.0		3.0	3.0
Recall Mode		None	None		None	None
Walk Time (s)			7.0			
Flash Don't Walk (s)			27.0			
Pedestrian Calls (#/hr)			0			
Act Effct Green (s)		20.8	20.8		15.7	15.7
Actuated g/C Ratio		0.46	0.46		0.34	0.34
v/c Ratio		0.39	0.74		0.51	0.36
Control Delay (s/veh)		9.6	16.1		17.1	4.1
Queue Delay		0.0	0.0		0.0	0.0
Total Delay (s/veh)		9.6	16.1		17.1	4.1
LOS		A	B		B	A
Approach Delay (s/veh)		9.6	16.1		11.3	
Approach LOS		A	B		B	

Intersection Summary

Area Type:	Other
Cycle Length:	90
Actuated Cycle Length:	45.7
Natural Cycle:	60
Control Type:	Actuated-Uncoordinated
Maximum v/c Ratio:	0.74
Intersection Signal Delay (s/veh):	12.9
Intersection LOS:	B
Intersection Capacity Utilization:	102.3%
ICU Level of Service:	G
Analysis Period (min):	15

Splits and Phases: 4: Shiloh Road & US 101 SB Off-Ramp

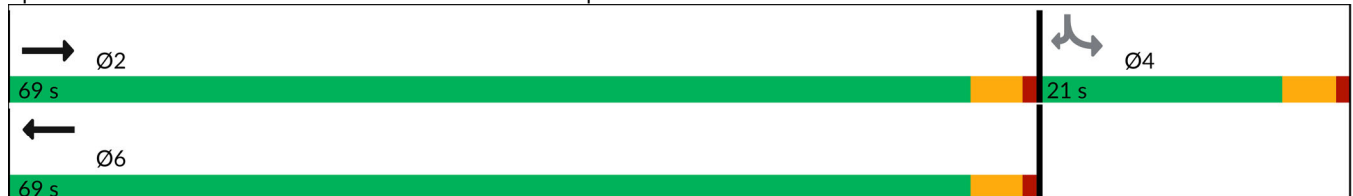

Lanes, Volumes, Timings  
5: Caletti Ave & Shiloh Road

2028 Opening Year No Project Conditions

Timing Plan: Saturday Midday Peak

	→	↘	↙	←	↖	↗
Lane Group	EBT	EBR	WBL	WBT	NBL	NBR
Lane Configurations	↑↑		↘	↑	↘	↗
Traffic Volume (vph)	612	23	92	676	18	89
Future Volume (vph)	612	23	92	676	18	89
Ideal Flow (vphp)	1900	1900	1900	1900	1900	1900
Storage Length (ft)		0	68		0	0
Storage Lanes		0	1		1	1
Taper Length (ft)			50		25	
Lane Util. Factor	0.95	0.95	1.00	1.00	1.00	1.00
Ped Bike Factor						
Frt	0.995					0.850
Flt Protected			0.950		0.950	
Satd. Flow (prot)	3522	0	1770	1863	1770	1583
Flt Permitted			0.950		0.950	
Satd. Flow (perm)	3522	0	1770	1863	1770	1583
Link Speed (mph)	40			40	30	
Link Distance (ft)	1081			184	459	
Travel Time (s)	18.4			3.1	10.4	
Confl. Peds. (#/hr)					1	
Confl. Bikes (#/hr)		1				
Peak Hour Factor	0.92	0.92	0.87	0.87	0.78	0.78
Adj. Flow (vph)	665	25	106	777	23	114
Shared Lane Traffic (%)						
Lane Group Flow (vph)	690	0	106	777	23	114
Enter Blocked Intersection	No	No	No	No	No	No
Lane Alignment	Left	Right	Left	Left	Left	Right
Median Width(ft)	12			12	12	
Link Offset(ft)	0			0	0	
Crosswalk Width(ft)	16			16	16	
Two way Left Turn Lane						
Headway Factor	1.00	1.00	1.00	1.00	1.00	1.00
Turning Speed (mph)		9	15		15	9
Sign Control	Free			Free	Stop	

Intersection Summary

Area Type:	Other
Control Type:	Unsignalized
Intersection Capacity Utilization	45.6%
Analysis Period (min)	15
	ICU Level of Service A

Lanes, Volumes, Timings  
6: Conde Lane & Shiloh Road

2028 Opening Year No Project Conditions  
Timing Plan: Saturday Midday Peak

Lane Group	EBL	EBT	EBR	WBL	WBT	WBR	NBL	NBT	NBR	SBL	SBT	SBR
Lane Configurations												
Traffic Volume (vph)	33	402	1	10	448	232	1	0	7	224	0	32
Future Volume (vph)	33	402	1	10	448	232	1	0	7	224	0	32
Ideal Flow (vphpl)	1900	1900	1900	1900	1900	1900	1900	1900	1900	1900	1900	1900
Storage Length (ft)	90		0	127		0	0		0	0		40
Storage Lanes	1		0	1		0	0		0	0		1
Taper Length (ft)	70			40			25			25		
Lane Util. Factor	1.00	0.95	0.95	1.00	0.95	0.95	1.00	1.00	1.00	1.00	1.00	1.00
Ped Bike Factor					0.99							
Frt					0.949			0.884				0.850
Flt Protected	0.950			0.950				0.993			0.950	
Satd. Flow (prot)	1770	3539	0	1770	3333	0	0	1635	0	0	1770	1583
Flt Permitted	0.950			0.950				0.993			0.950	
Satd. Flow (perm)	1770	3539	0	1770	3333	0	0	1635	0	0	1770	1583
Right Turn on Red			Yes			Yes			Yes			No
Satd. Flow (RTOR)					94			102				
Link Speed (mph)		40			40			30				35
Link Distance (ft)		815			1081			418				522
Travel Time (s)		13.9			18.4			9.5				10.2
Confl. Bikes (#/hr)						2						
Peak Hour Factor	0.96	0.96	0.96	0.91	0.91	0.91	0.58	0.58	0.58	0.78	0.78	0.78
Adj. Flow (vph)	34	419	1	11	492	255	2	0	12	287	0	41
Shared Lane Traffic (%)												
Lane Group Flow (vph)	34	420	0	11	747	0	0	14	0	0	287	41
Enter Blocked Intersection	No	No	No	No	No	No	No	No	No	No	No	No
Lane Alignment	Left	Left	Right	Left	Left	Right	Left	Left	Right	Left	Left	Right
Median Width(ft)		12			12			0				0
Link Offset(ft)		0			0			0				0
Crosswalk Width(ft)		16			16			16				16
Two way Left Turn Lane												
Headway Factor	1.00	1.00	1.00	1.00	1.00	1.00	1.00	1.00	1.00	1.00	1.00	1.00
Turning Speed (mph)	15		9	15		9	15		9	15		9
Number of Detectors	1	2		1	2		1	2		1	1	1
Detector Template	Left	Thru		Left	Thru		Left	Thru		Left	Thru	Right
Leading Detector (ft)	20	100		20	100		20	100		20	30	20
Trailing Detector (ft)	0	0		0	0		0	0		0	0	0
Detector 1 Position(ft)	0	0		0	0		0	0		0	0	0
Detector 1 Size(ft)	20	6		20	6		20	6		20	30	20
Detector 1 Type	Cl+Ex	Cl+Ex		Cl+Ex	Cl+Ex		Cl+Ex	Cl+Ex		Cl+Ex	Cl+Ex	Cl+Ex
Detector 1 Channel												
Detector 1 Extend (s)	0.0	0.0		0.0	0.0		0.0	0.0		0.0	0.0	0.0
Detector 1 Queue (s)	0.0	0.0		0.0	0.0		0.0	0.0		0.0	0.0	0.0
Detector 1 Delay (s)	0.0	0.0		0.0	0.0		0.0	0.0		0.0	0.0	0.0
Detector 2 Position(ft)		94			94			94				
Detector 2 Size(ft)		6			6			6				
Detector 2 Type		Cl+Ex			Cl+Ex			Cl+Ex				
Detector 2 Channel												
Detector 2 Extend (s)		0.0			0.0			0.0				
Turn Type	Prot	NA		Prot	NA		Split	NA		Split	NA	custom

Lanes, Volumes, Timings  
6: Conde Lane & Shiloh Road

2028 Opening Year No Project Conditions

Timing Plan: Saturday Midday Peak

Lane Group	EBL	EBT	EBR	WBL	WBT	WBR	NBL	NBT	NBR	SBL	SBT	SBR
Protected Phases	5	2		1	6		7	7		4	4	
Permitted Phases												6
Detector Phase	5	2		1	6		7	7		4	4	6
Switch Phase												
Minimum Initial (s)	8.0	8.0		8.0	8.0		10.0	10.0		11.0	11.0	8.0
Minimum Split (s)	12.5	46.5		12.5	12.5		37.5	37.5		15.5	15.5	12.5
Total Split (s)	13.0	46.5		12.5	45.0		37.5	37.5		15.5	15.5	45.0
Total Split (%)	11.6%	41.5%		11.2%	40.2%		33.5%	33.5%		13.8%	13.8%	40.2%
Maximum Green (s)	8.5	42.0		8.0	40.5		33.0	33.0		11.0	11.0	40.5
Yellow Time (s)	3.5	3.5		3.5	3.5		3.5	3.5		3.5	3.5	3.5
All-Red Time (s)	1.0	1.0		1.0	1.0		1.0	1.0		1.0	1.0	1.0
Lost Time Adjust (s)	0.0	0.0		0.0	0.0		0.0	0.0		0.0	0.0	0.0
Total Lost Time (s)	4.5	4.5		4.5	4.5		4.5	4.5		4.5	4.5	4.5
Lead/Lag	Lead	Lag		Lead	Lag							Lag
Lead-Lag Optimize?	Yes	Yes		Yes	Yes							Yes
Vehicle Extension (s)	3.0	3.0		3.0	3.0		3.0	3.0		3.0	3.0	3.0
Recall Mode	None	None		None	None		None	None		None	None	None
Walk Time (s)		7.0					7.0	7.0				
Flash Don't Walk (s)		35.0					26.0	26.0				
Pedestrian Calls (#/hr)		0					0	0				
Act Effct Green (s)	9.1	19.1		9.0	16.8			11.2			12.4	16.8
Actuated g/C Ratio	0.20	0.43		0.20	0.38			0.25			0.28	0.38
v/c Ratio	0.09	0.28		0.03	0.57			0.03			0.59	0.07
Control Delay (s/veh)	23.3	9.9		23.9	12.8			0.1			27.9	12.2
Queue Delay	0.0	0.0		0.0	0.0			0.0			0.0	0.0
Total Delay (s/veh)	23.3	9.9		23.9	12.8			0.1			27.9	12.2
LOS	C	A		C	B			A			C	B
Approach Delay (s/veh)		10.9			12.9			0.1			25.9	
Approach LOS		B			B			A			C	

Intersection Summary

Area Type:	Other
Cycle Length:	112
Actuated Cycle Length:	44.8
Natural Cycle:	115
Control Type:	Actuated-Uncoordinated
Maximum v/c Ratio:	0.59
Intersection Signal Delay (s/veh):	15.0
Intersection LOS:	B
Intersection Capacity Utilization:	54.0%
ICU Level of Service:	A
Analysis Period (min):	15



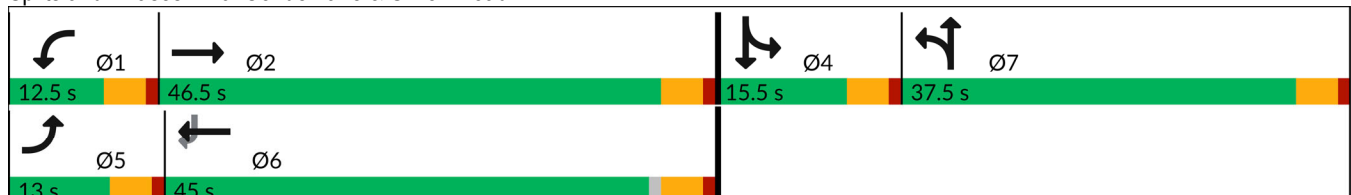













Splits and Phases: 6: Conde Lane & Shiloh Road



Lanes, Volumes, Timings  
7: Entrance 1/Gridley Drive & Shiloh Road



















2028 Opening Year No Project Conditions

Timing Plan: Saturday Midday Peak

												
Lane Group	EBL	EBT	EBR	WBL	WBT	WBR	NBL	NBT	NBR	SBL	SBT	SBR
Lane Configurations												
Traffic Volume (vph)	23	121	0	0	105	0	0	0	0	0	0	20
Future Volume (vph)	23	121	0	0	105	0	0	0	0	0	0	20
Ideal Flow (vphpl)	1900	1900	1900	1900	1900	1900	1900	1900	1900	1900	1900	1900
Lane Util. Factor	1.00	1.00	1.00	1.00	1.00	1.00	1.00	1.00	1.00	1.00	1.00	1.00
Ped Bike Factor												
Frt												0.865
Flt Protected	0.992											
Satd. Flow (prot)	0	1848	0	0	1863	0	1863	1863	0	0	1611	0
Flt Permitted	0.992											
Satd. Flow (perm)	0	1848	0	0	1863	0	1863	1863	0	0	1611	0
Link Speed (mph)	40		40				30			30		
Link Distance (ft)	608		2146				248			715		
Travel Time (s)	10.4		36.6				5.6			16.3		
Confl. Peds. (#/hr)	1											
Confl. Bikes (#/hr)	1				3							
Peak Hour Factor	0.93	0.93	0.93	0.88	0.88	0.88	1.00	1.00	1.00	0.56	0.56	0.56
Adj. Flow (vph)	25	130	0	0	119	0	0	0	0	0	0	36
Shared Lane Traffic (%)												
Lane Group Flow (vph)	0	155	0	0	119	0	0	0	0	0	36	0
Enter Blocked Intersection	No	No	No	No	No	No	No	No	No	No	No	No
Lane Alignment	Left	Left	Right	Left	Left	Right	Left	Left	Right	Left	Left	Right
Median Width(ft)	0		0				12			12		
Link Offset(ft)	0		0				0			0		
Crosswalk Width(ft)	16		16				16			16		
Two way Left Turn Lane												
Headway Factor	1.00	1.00	1.00	1.00	1.00	1.00	1.00	1.00	1.00	1.00	1.00	1.00
Turning Speed (mph)	15		9		15		9		15		9	
Sign Control	Free				Free				Stop			
<b>Intersection Summary</b>												
Area Type:	Other											
Control Type:	Unsignalized											
Intersection Capacity Utilization	24.3%						ICU Level of Service A					
Analysis Period (min)	15											

Lanes, Volumes, Timings  
8: Old Redwood Hwy & Entrance 1

2028 Opening Year No Project Conditions  
Timing Plan: Saturday Midday Peak

												
Lane Group	EBL	EBT	EBR	WBL	WBT	WBR	NBL	NBT	NBR	SBL	SBT	SBR
Lane Configurations												
Traffic Volume (vph)	1	0	2	0	0	0	1	459	0	0	389	5
Future Volume (vph)	1	0	2	0	0	0	1	459	0	0	389	5
Ideal Flow (vphp)	1900	1900	1900	1900	1900	1900	1900	1900	1900	1900	1900	1900
Storage Length (ft)	0		0	0		0	0		0	50		0
Storage Lanes	0		0	1		0	0		0	1		0
Taper Length (ft)	25			25			25			25		
Lane Util. Factor	1.00	1.00	1.00	1.00	1.00	1.00	1.00	1.00	1.00	1.00	1.00	1.00
Ped Bike Factor												
Frt		0.916									0.998	
Flt Protected		0.982										
Satd. Flow (prot)	0	1676	0	1863	1863	0	0	1863	0	1863	1859	0
Flt Permitted		0.982										
Satd. Flow (perm)	0	1676	0	1863	1863	0	0	1863	0	1863	1859	0
Link Speed (mph)		30			30			45			45	
Link Distance (ft)		98			385			520			748	
Travel Time (s)		2.2			8.8			7.9			11.3	
Confl. Peds. (#/hr)							1		4	4		1
Confl. Bikes (#/hr)									3			9
Peak Hour Factor	0.38	0.38	0.38	1.00	1.00	1.00	0.94	0.94	0.94	0.93	0.93	0.93
Adj. Flow (vph)	3	0	5	0	0	0	1	488	0	0	418	5
Shared Lane Traffic (%)												
Lane Group Flow (vph)	0	8	0	0	0	0	0	489	0	0	423	0
Enter Blocked Intersection	No	No	No	No	No	No	No	No	No	No	No	No
Lane Alignment	Left	Left	Right	Left	Left	Right	Left	Left	Right	Left	Left	Right
Median Width(ft)		12			12			12			12	
Link Offset(ft)		0			0			0			0	
Crosswalk Width(ft)		16			16			16			16	
Two way Left Turn Lane												
Headway Factor	1.00	1.00	1.00	1.00	1.00	1.00	1.00	1.00	1.00	1.00	1.00	1.00
Turning Speed (mph)	15		9	15		9	15		9	15		9
Sign Control		Stop			Stop			Free			Free	

Intersection Summary	
Area Type:	Other
Control Type:	Unsignalized
Intersection Capacity Utilization	35.0%
Analysis Period (min)	15
	ICU Level of Service A

Lanes, Volumes, Timings  
9: Entrance 2 & Shiloh Road

2028 Opening Year No Project Conditions

Timing Plan: Saturday Midday Peak

	→	↘	↙	←	↖	↗
Lane Group	EBT	EBR	WBL	WBT	NBL	NBR
Lane Configurations	↗			↖	↘	↗
Traffic Volume (vph)	105	0	0	98	0	0
Future Volume (vph)	105	0	0	98	0	0
Ideal Flow (vphpl)	1900	1900	1900	1900	1900	1900
Lane Util. Factor	1.00	1.00	1.00	1.00	1.00	1.00
Ped Bike Factor						
Frt						
Flt Protected						
Satd. Flow (prot)	1863	0	0	1863	1863	1863
Flt Permitted						
Satd. Flow (perm)	1863	0	0	1863	1863	1863
Link Speed (mph)	40			40	30	
Link Distance (ft)	2146			134	402	
Travel Time (s)	36.6			2.3	9.1	
Confl. Peds. (#/hr)		1				
Peak Hour Factor	0.88	0.88	0.80	0.80	1.00	1.00
Adj. Flow (vph)	119	0	0	123	0	0
Shared Lane Traffic (%)						
Lane Group Flow (vph)	119	0	0	123	0	0
Enter Blocked Intersection	No	No	No	No	No	No
Lane Alignment	Left	Right	Left	Left	Left	Right
Median Width(ft)	0			0	12	
Link Offset(ft)	0			0	0	
Crosswalk Width(ft)	16			16	16	
Two way Left Turn Lane						
Headway Factor	1.00	1.00	1.00	1.00	1.00	1.00
Turning Speed (mph)		9	15		15	9
Sign Control	Free			Free	Stop	
<b>Intersection Summary</b>						
Area Type:	Other					
Control Type:	Unsignalized					
Intersection Capacity Utilization	9.1%			ICU Level of Service A		
Analysis Period (min)	15					

Lanes, Volumes, Timings

2028 Opening Year No Project Conditions

10: US 101 NB Off Ramp/Lakewood Drive & Old Redwood Highway Timing Plan: Saturday Midday Peak



Lane Group	EBL	EBT	EBR	WBL	WBT	WBR	NBL	NBT	NBR	SBL	SBT	SBR
Lane Configurations												
Traffic Volume (vph)	287	313	0	0	502	276	320	303	142	244	0	700
Future Volume (vph)	287	313	0	0	502	276	320	303	142	244	0	700
Ideal Flow (vphpl)	1900	1900	1900	1900	1900	1900	1900	1900	1900	1900	1900	1900
Storage Length (ft)	155		0	0		0	270		150	120		0
Storage Lanes	1		0	0		0	1		1	1		1
Taper Length (ft)	50			25			165			75		
Lane Util. Factor	0.97	1.00	1.00	1.00	0.95	0.95	0.91	0.91	0.95	0.97	1.00	1.00
Ped Bike Factor	1.00				0.99			1.00		1.00		
Fr <sub>t</sub>					0.947			0.958				0.850
Fl <sub>t</sub> Protected	0.950						0.950	0.994		0.950		
Satd. Flow (prot)	3433	1863	0	0	3332	0	1610	3217	0	3433	0	1583
Fl <sub>t</sub> Permitted	0.950						0.950	0.994		0.950		
Satd. Flow (perm)	3429	1863	0	0	3332	0	1610	3217	0	3430	0	1583
Right Turn on Red			Yes			Yes			Yes			Yes
Satd. Flow (RTOR)					121			61				296
Link Speed (mph)		35			35			30				30
Link Distance (ft)		226			617			716				478
Travel Time (s)		4.4			12.0			16.3				10.9
Confl. Peds. (#/hr)	2		1	1		2			1	1		
Confl. Bikes (#/hr)			10			3						
Peak Hour Factor	0.95	0.95	0.95	0.89	0.89	0.89	0.98	0.98	0.98	0.88	0.88	0.88
Adj. Flow (vph)	302	329	0	0	564	310	327	309	145	277	0	795
Shared Lane Traffic (%)							20%					
Lane Group Flow (vph)	302	329	0	0	874	0	262	519	0	277	0	795
Enter Blocked Intersection	No	No	No	No	No	No	No	No	No	No	No	No
Lane Alignment	Left	Left	Right	Left	Left	Right	Left	Left	Right	Left	Left	Right
Median Width(ft)		24			24			24				24
Link Offset(ft)		0			0			0				0
Crosswalk Width(ft)		16			16			16				16
Two way Left Turn Lane												
Headway Factor	1.00	1.00	1.00	1.00	1.00	1.00	1.00	1.00	1.00	1.00	1.00	1.00
Turning Speed (mph)	15		9	15		9	15		9	15		9
Number of Detectors	1	2			2		1	2		1		1
Detector Template	Left	Thru			Thru		Left	Thru		Left		Right
Leading Detector (ft)	20	100			100		20	100		20		20
Trailing Detector (ft)	0	0			0		0	0		0		0
Detector 1 Position(ft)	0	0			0		0	0		0		0
Detector 1 Size(ft)	20	6			6		20	6		20		20
Detector 1 Type	Cl+Ex	Cl+Ex			Cl+Ex		Cl+Ex	Cl+Ex		Cl+Ex		Cl+Ex
Detector 1 Channel												
Detector 1 Extend (s)	0.0	0.0			0.0		0.0	0.0		0.0		0.0
Detector 1 Queue (s)	0.0	0.0			0.0		0.0	0.0		0.0		0.0
Detector 1 Delay (s)	0.0	0.0			0.0		0.0	0.0		0.0		0.0
Detector 2 Position(ft)		94			94			94				
Detector 2 Size(ft)		6			6			6				
Detector 2 Type		Cl+Ex			Cl+Ex			Cl+Ex				
Detector 2 Channel												
Detector 2 Extend (s)		0.0			0.0			0.0				



Lanes, Volumes, Timings

2028 Opening Year No Project Conditions

10: US 101 NB Off Ramp/Lakewood Drive & Old Redwood Highway Timing Plan: Saturday Midday Peak



Lane Group	EBL	EBT	EBR	WBL	WBT	WBR	NBL	NBT	NBR	SBL	SBT	SBR
Turn Type	Prot	NA			NA		Split	NA		Prot		pm+ov
Protected Phases	5	2			6		8	8		7		5
Permitted Phases												5 8
Detector Phase	5	2			6		8	8		7		5
Switch Phase												
Minimum Initial (s)	7.0	10.0			10.0		10.0	10.0		7.0		7.0
Minimum Split (s)	11.5	32.1			32.1		33.7	33.7		11.5		11.5
Total Split (s)	12.0	45.3			33.3		33.7	33.7		11.5		12.0
Total Split (%)	13.3%	50.1%			36.8%		37.2%	37.2%		12.7%		13.3%
Maximum Green (s)	7.5	40.8			28.8		29.2	29.2		7.0		7.5
Yellow Time (s)	3.5	3.5			3.5		3.5	3.5		3.5		3.5
All-Red Time (s)	1.0	1.0			1.0		1.0	1.0		1.0		1.0
Lost Time Adjust (s)	0.0	0.0			0.0		0.0	0.0		0.0		0.0
Total Lost Time (s)	4.5	4.5			4.5		4.5	4.5		4.5		4.5
Lead/Lag	Lead				Lag		Lag	Lag		Lead		Lead
Lead-Lag Optimize?	Yes				Yes		Yes	Yes		Yes		Yes
Vehicle Extension (s)	3.0	3.0			3.0		3.0	3.0		3.0		3.0
Recall Mode	None	Max			Max		None	None		None		None
Walk Time (s)		7.0			7.0		7.0	7.0				
Flash Don't Walk (s)		20.0			17.0		22.0	22.0				
Pedestrian Calls (#/hr)		0			0		0	0				
Act Effct Green (s)	7.5	41.0			29.0		20.3	20.3		7.0		32.4
Actuated g/C Ratio	0.09	0.50			0.35		0.25	0.25		0.09		0.40
v/c Ratio	0.96	0.35			0.70		0.66	0.61		0.94		0.99
Control Delay (s/veh)	81.7	15.1			23.9		35.6	26.8		80.3		45.6
Queue Delay	0.0	0.0			0.0		0.0	0.0		0.0		0.0
Total Delay (s/veh)	81.7	15.1			23.9		35.6	26.8		80.3		45.6
LOS	F	B			C		D	C		F		D
Approach Delay (s/veh)		47.0			23.9			29.8				54.6
Approach LOS		D			C			C				D

Intersection Summary

Area Type: Other  
 Cycle Length: 90.5  
 Actuated Cycle Length: 82  
 Natural Cycle: 90  
 Control Type: Actuated-Uncoordinated  
 Maximum v/c Ratio: 0.99  
 Intersection Signal Delay (s/veh): 39.4  
 Intersection LOS: D  
 Intersection Capacity Utilization 92.5%  
 ICU Level of Service F  
 Analysis Period (min) 15

Splits and Phases: 10: US 101 NB Off Ramp/Lakewood Drive & Old Redwood Highway

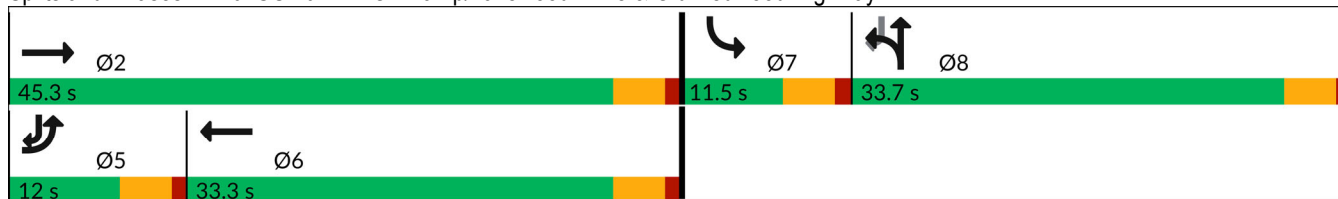

Lanes, Volumes, Timings  
 11: Old Redwood Highway & US 101 NB On Ramp

2028 Opening Year No Project Conditions  
 Timing Plan: Saturday Midday Peak



Lane Group	EBL	EBT	WBT	WBR	SBL	SBR
Lane Configurations	↶	↕↕	↶↶			
Traffic Volume (vph)	87	605	1310	215	0	0
Future Volume (vph)	87	605	1310	215	0	0
Ideal Flow (vphp)	1900	1900	1900	1900	1900	1900
Storage Length (ft)	245			0	0	0
Storage Lanes	1			0	0	0
Taper Length (ft)	50				25	
Lane Util. Factor	1.00	0.95	0.95	0.95	1.00	1.00
Ped Bike Factor						
Frt			0.979			
Flt Protected	0.950					
Satd. Flow (prot)	1770	3539	3465	0	0	0
Flt Permitted	0.950					
Satd. Flow (perm)	1770	3539	3465	0	0	0
Link Speed (mph)		35	35		30	
Link Distance (ft)		531	226		299	
Travel Time (s)		10.3	4.4		6.8	
Confl. Peds. (#/hr)	8			8		
Confl. Bikes (#/hr)				4		
Peak Hour Factor	0.96	0.96	0.92	0.92	0.25	0.25
Adj. Flow (vph)	91	630	1424	234	0	0
Shared Lane Traffic (%)						
Lane Group Flow (vph)	91	630	1658	0	0	0
Enter Blocked Intersection	No	No	No	No	No	No
Lane Alignment	Left	Left	Left	Right	Left	Right
Median Width(ft)		12	12		0	
Link Offset(ft)		0	0		0	
Crosswalk Width(ft)		16	16		16	
Two way Left Turn Lane						
Headway Factor	1.00	1.00	1.00	1.00	1.00	1.00
Turning Speed (mph)	15			9	15	9
Sign Control		Free	Free		Free	

Intersection Summary	
Area Type:	Other
Control Type:	Unsignalized
Intersection Capacity Utilization	72.7%
Analysis Period (min)	15
	ICU Level of Service C

Lanes, Volumes, Timings

2028 Opening Year No Project Conditions

12: US 101 SB On Ramp/US 101 SB Off Ramp & Old Redwood Highway Timing Plan: Saturday Midday Peak



Lane Group	EBL	EBT	EBR	WBL	WBT	WBR	NBL	NBT	NBR	SBL	SBT	SBR
Lane Configurations		↑↑	↗	↘	↑↑					↘	↕	
Traffic Volume (vph)	0	550	419	487	818	0	0	0	0	151	1	87
Future Volume (vph)	0	550	419	487	818	0	0	0	0	151	1	87
Ideal Flow (vphpl)	1900	1900	1900	1900	1900	1900	1900	1900	1900	1900	1900	1900
Storage Length (ft)	0		0	250		0	0		0	420		0
Storage Lanes	0		1	0		0	0		0	1		0
Taper Length (ft)	25			165			25			75		
Lane Util. Factor	1.00	0.95	1.00	1.00	0.95	1.00	1.00	1.00	1.00	0.95	0.95	1.00
Ped Bike Factor			0.98	1.00								
Frt			0.850									0.885
Flt Protected				0.950						0.950	0.989	
Satd. Flow (prot)	0	3539	1583	1770	3539	0	0	0	0	1681	1549	0
Flt Permitted				0.950						0.950	0.989	
Satd. Flow (perm)	0	3539	1553	1768	3539	0	0	0	0	1681	1549	0
Right Turn on Red			Yes			Yes			Yes			Yes
Satd. Flow (RTOR)			432									121
Link Speed (mph)		35			35			30				30
Link Distance (ft)		423			531			621				831
Travel Time (s)		8.2			10.3			14.1				18.9
Confl. Peds. (#/hr)	11		2	2		11						
Confl. Bikes (#/hr)			10			2						
Peak Hour Factor	0.97	0.97	0.97	0.96	0.96	0.96	0.25	0.25	0.25	0.72	0.72	0.72
Adj. Flow (vph)	0	567	432	507	852	0	0	0	0	210	1	121
Shared Lane Traffic (%)										17%		
Lane Group Flow (vph)	0	567	432	507	852	0	0	0	0	174	158	0
Enter Blocked Intersection	No	No	No	No	No	No	No	No	No	No	No	No
Lane Alignment	Left	Left	Right	Left	Left	Right	Left	Left	Right	Left	Left	Right
Median Width(ft)		24			24			12				12
Link Offset(ft)		0			0			0				0
Crosswalk Width(ft)		16			16			16				16
Two way Left Turn Lane												
Headway Factor	1.00	1.00	1.00	1.00	1.00	1.00	1.00	1.00	1.00	1.00	1.00	1.00
Turning Speed (mph)	15		9	15		9	15		9	15		9
Number of Detectors		2	1	1	2					1	2	
Detector Template		Thru	Right	Left	Thru					Left	Thru	
Leading Detector (ft)		100	20	20	100					20	100	
Trailing Detector (ft)		0	0	0	0					0	0	
Detector 1 Position(ft)		0	0	0	0					0	0	
Detector 1 Size(ft)		6	20	20	6					20	6	
Detector 1 Type		Cl+Ex	Cl+Ex	Cl+Ex	Cl+Ex					Cl+Ex	Cl+Ex	
Detector 1 Channel												
Detector 1 Extend (s)		0.0	0.0	0.0	0.0					0.0	0.0	
Detector 1 Queue (s)		0.0	0.0	0.0	0.0					0.0	0.0	
Detector 1 Delay (s)		0.0	0.0	0.0	0.0					0.0	0.0	
Detector 2 Position(ft)		94			94							94
Detector 2 Size(ft)		6			6							6
Detector 2 Type		Cl+Ex			Cl+Ex							Cl+Ex
Detector 2 Channel												
Detector 2 Extend (s)		0.0			0.0							0.0

Lanes, Volumes, Timings

2028 Opening Year No Project Conditions

12: US 101 SB On Ramp/US 101 SB Off Ramp & Old Redwood Highway Timing Plan: Saturday Midday Peak



Lane Group	EBL	EBT	EBR	WBL	WBT	WBR	NBL	NBT	NBR	SBL	SBT	SBR
Turn Type		NA	Perm	Prot	NA					Perm	NA	
Protected Phases		6		5	2						8	
Permitted Phases			6							8		
Detector Phase		6	6	5	2					8	8	
Switch Phase												
Minimum Initial (s)		10.0	10.0	7.0	10.0					10.0	10.0	
Minimum Split (s)		32.1	32.1	11.5	38.1					14.7	14.7	
Total Split (s)		32.3	32.3	23.0	55.3					14.7	14.7	
Total Split (%)		46.1%	46.1%	32.9%	79.0%					21.0%	21.0%	
Maximum Green (s)		27.8	27.8	18.5	50.8					10.2	10.2	
Yellow Time (s)		3.5	3.5	3.5	3.5					3.5	3.5	
All-Red Time (s)		1.0	1.0	1.0	1.0					1.0	1.0	
Lost Time Adjust (s)		0.0	0.0	0.0	0.0					0.0	0.0	
Total Lost Time (s)		4.5	4.5	4.5	4.5					4.5	4.5	
Lead/Lag		Lag	Lag	Lead								
Lead-Lag Optimize?		Yes	Yes	Yes								
Vehicle Extension (s)		3.0	3.0	3.0	3.0					3.0	3.0	
Recall Mode		Max	Max	None	Max					None	None	
Walk Time (s)		7.0	7.0		7.0							
Flash Don't Walk (s)		20.0	20.0		25.0							
Pedestrian Calls (#/hr)		0	0		0							
Act Effct Green (s)		27.8	27.8	18.5	50.8					10.2	10.2	
Actuated g/C Ratio		0.40	0.40	0.26	0.73					0.15	0.15	
v/c Ratio		0.40	0.49	1.09	0.33					0.72	0.48	
Control Delay (s/veh)		16.2	3.8	94.8	3.9					47.2	14.6	
Queue Delay		0.0	0.0	0.0	0.0					0.0	0.0	
Total Delay (s/veh)		16.2	3.8	94.8	3.9					47.2	14.6	
LOS		B	A	F	A					D	B	
Approach Delay (s/veh)		10.9			37.8						31.7	
Approach LOS		B			D						C	

Intersection Summary

Area Type: Other  
 Cycle Length: 70  
 Actuated Cycle Length: 70  
 Natural Cycle: 80  
 Control Type: Actuated-Uncoordinated  
 Maximum v/c Ratio: 1.09  
 Intersection Signal Delay (s/veh): 27.0 Intersection LOS: C  
 Intersection Capacity Utilization 72.7% ICU Level of Service C  
 Analysis Period (min) 15



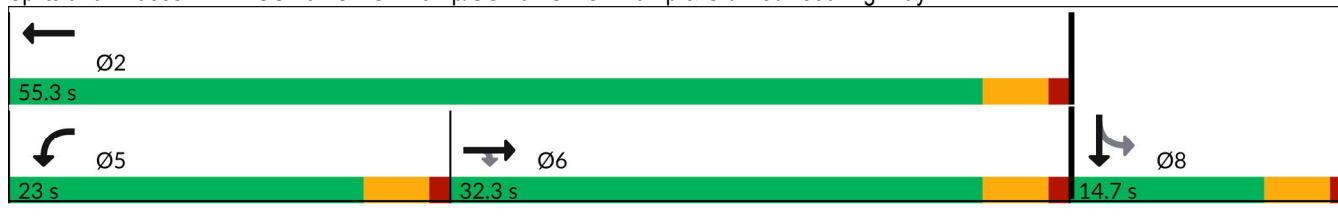



















Splits and Phases: 12: US 101 SB On Ramp/US 101 SB Off Ramp & Old Redwood Highway



Appendix G – Opening Year 2028 plus Alternative A Project  
Conditions Intersection Level of Service Worksheets

HCM 6th Signalized Intersection Summary  
 1: Old Redwood Hwy & Shiloh Road

























2028 Opening Year Alter. A Conditions  
 Timing Plan: A.M. PEAK

												
Movement	EBL	EBT	EBR	WBL	WBT	WBR	NBL	NBT	NBR	SBL	SBT	SBR
Lane Configurations												
Traffic Volume (veh/h)	137	290	135	25	180	28	120	146	39	37	269	208
Future Volume (veh/h)	137	290	135	25	180	28	120	146	39	37	269	208
Initial Q (Qb), veh	0	0	0	0	0	0	0	0	0	0	0	0
Ped-Bike Adj(A_pbT)	1.00		1.00	1.00		1.00	1.00		1.00	1.00		0.98
Parking Bus, Adj	1.00	1.00	1.00	1.00	1.00	1.00	1.00	1.00	1.00	1.00	1.00	1.00
Work Zone On Approach		No			No			No			No	
Adj Sat Flow, veh/h/ln	1870	1870	1870	1870	1870	1870	1870	1870	1870	1870	1870	1870
Adj Flow Rate, veh/h	169	358	167	28	202	31	129	157	42	44	316	245
Peak Hour Factor	0.81	0.81	0.81	0.89	0.89	0.89	0.93	0.93	0.93	0.85	0.85	0.85
Percent Heavy Veh, %	2	2	2	2	2	2	2	2	2	2	2	2
Cap, veh/h	445	467	396	38	272	264	183	474	402	134	423	351
Arrive On Green	0.25	0.25	0.25	0.17	0.17	0.17	0.10	0.25	0.25	0.08	0.23	0.23
Sat Flow, veh/h	1781	1870	1585	226	1633	1585	1781	1870	1585	1781	1870	1551
Grp Volume(v), veh/h	169	358	167	230	0	31	129	157	42	44	316	245
Grp Sat Flow(s),veh/h/ln	1781	1870	1585	1859	0	1585	1781	1870	1585	1781	1870	1551
Q Serve(g_s), s	5.2	11.8	5.9	7.8	0.0	1.1	4.7	4.6	1.4	1.6	10.5	9.7
Cycle Q Clear(g_c), s	5.2	11.8	5.9	7.8	0.0	1.1	4.7	4.6	1.4	1.6	10.5	9.7
Prop In Lane	1.00		1.00	0.12		1.00	1.00		1.00	1.00		1.00
Lane Grp Cap(c), veh/h	445	467	396	309	0	264	183	474	402	134	423	351
V/C Ratio(X)	0.38	0.77	0.42	0.74	0.00	0.12	0.71	0.33	0.10	0.33	0.75	0.70
Avail Cap(c_a), veh/h	815	856	726	1060	0	904	388	1221	1035	160	982	815
HCM Platoon Ratio	1.00	1.00	1.00	1.00	1.00	1.00	1.00	1.00	1.00	1.00	1.00	1.00
Upstream Filter(I)	1.00	1.00	1.00	1.00	0.00	1.00	1.00	1.00	1.00	1.00	1.00	1.00
Uniform Delay (d), s/veh	20.7	23.2	21.0	26.4	0.0	23.6	28.9	20.3	19.1	29.2	24.0	23.7
Incr Delay (d2), s/veh	0.5	2.7	0.7	3.5	0.0	0.2	4.9	0.4	0.1	1.4	2.7	2.5
Initial Q Delay(d3),s/veh	0.0	0.0	0.0	0.0	0.0	0.0	0.0	0.0	0.0	0.0	0.0	0.0
%ile BackOfQ(50%),veh/ln	2.0	5.0	2.0	3.5	0.0	0.4	2.1	1.8	0.5	0.7	4.5	3.4
Unsig. Movement Delay, s/veh												
LnGrp Delay(d),s/veh	21.2	25.8	21.7	30.0	0.0	23.8	33.9	20.7	19.2	30.6	26.7	26.2
LnGrp LOS	C	C	C	C	A	C	C	C	B	C	C	C
Approach Vol, veh/h		694			261			328			605	
Approach Delay, s/veh		23.7			29.2			25.7			26.8	
Approach LOS		C			C			C			C	
Timer - Assigned Phs		2	3	4		6	7	8				
Phs Duration (G+Y+Rc), s		21.2	10.3	19.6		15.6	8.5	21.4				
Change Period (Y+Rc), s		4.5	3.5	4.5		4.5	3.5	4.5				
Max Green Setting (Gmax), s		30.5	14.5	35.0		38.0	6.0	43.5				
Max Q Clear Time (g_c+I1), s		13.8	6.7	12.5		9.8	3.6	6.6				
Green Ext Time (p_c), s		2.8	0.2	2.6		1.3	0.0	0.9				
<b>Intersection Summary</b>												
HCM 6th Ctrl Delay			25.8									
HCM 6th LOS			C									

HCM 6th Signalized Intersection Summary  
2: Shiloh Road & Hembree Ln

2028 Opening Year Alter. A Conditions

Timing Plan: A.M. PEAK

												
Movement	EBL	EBT	EBR	WBL	WBT	WBR	NBL	NBT	NBR	SBL	SBT	SBR
Lane Configurations	 			 	 						 	
Traffic Volume (veh/h)	347	511	38	19	466	82	39	7	11	81	9	413
Future Volume (veh/h)	347	511	38	19	466	82	39	7	11	81	9	413
Initial Q (Qb), veh	0	0	0	0	0	0	0	0	0	0	0	0
Ped-Bike Adj(A_pbT)	1.00		1.00	1.00		1.00	1.00		1.00	1.00		1.00
Parking Bus, Adj	1.00	1.00	1.00	1.00	1.00	1.00	1.00	1.00	1.00	1.00	1.00	1.00
Work Zone On Approach		No			No			No			No	
Adj Sat Flow, veh/h/ln	1870	1870	1870	1870	1870	1870	1870	1870	1870	1870	1870	1870
Adj Flow Rate, veh/h	394	581	38	19	480	85	39	7	11	86	9	439
Peak Hour Factor	0.88	0.88	1.00	1.00	0.97	0.97	1.00	1.00	1.00	0.94	1.00	0.94
Percent Heavy Veh, %	2	2	2	2	2	2	2	2	2	2	2	2
Cap, veh/h	570	724	47	41	831	146	96	35	56	315	33	570
Arrive On Green	0.16	0.42	0.42	0.02	0.28	0.28	0.05	0.05	0.05	0.19	0.19	0.19
Sat Flow, veh/h	3456	1736	114	1781	3020	532	1781	655	1030	1620	170	1585
Grp Volume(v), veh/h	394	0	619	19	281	284	39	0	18	95	0	439
Grp Sat Flow(s),veh/h/ln	1728	0	1850	1781	1777	1775	1781	0	1685	1789	0	1585
Q Serve(g_s), s	5.5	0.0	15.1	0.5	7.0	7.1	1.1	0.0	0.5	2.3	0.0	10.0
Cycle Q Clear(g_c), s	5.5	0.0	15.1	0.5	7.0	7.1	1.1	0.0	0.5	2.3	0.0	10.0
Prop In Lane	1.00		0.06	1.00		0.30	1.00		0.61	0.91		1.00
Lane Grp Cap(c), veh/h	570	0	771	41	489	488	96	0	91	348	0	570
V/C Ratio(X)	0.69	0.00	0.80	0.46	0.58	0.58	0.40	0.00	0.20	0.27	0.00	0.77
Avail Cap(c_a), veh/h	1143	0	1907	191	1434	1433	191	0	180	348	0	570
HCM Platoon Ratio	1.00	1.00	1.00	1.00	1.00	1.00	1.00	1.00	1.00	1.00	1.00	1.00
Upstream Filter(I)	1.00	0.00	1.00	1.00	1.00	1.00	1.00	0.00	1.00	1.00	0.00	1.00
Uniform Delay (d), s/veh	20.2	0.0	13.1	24.8	16.0	16.1	23.5	0.0	23.2	17.6	0.0	14.6
Incr Delay (d2), s/veh	1.5	0.0	2.0	7.8	1.1	1.1	2.7	0.0	1.0	0.4	0.0	6.4
Initial Q Delay(d3),s/veh	0.0	0.0	0.0	0.0	0.0	0.0	0.0	0.0	0.0	0.0	0.0	0.0
%ile BackOfQ(50%),veh/ln	2.0	0.0	5.1	0.3	2.5	2.5	0.5	0.0	0.2	0.9	0.0	4.8
Unsig. Movement Delay, s/veh												
LnGrp Delay(d),s/veh	21.8	0.0	15.1	32.6	17.1	17.2	26.2	0.0	24.3	18.0	0.0	21.0
LnGrp LOS	C	A	B	C	B	B	C	A	C	B	A	C
Approach Vol, veh/h		1013			584			57				534
Approach Delay, s/veh		17.7			17.6			25.6				20.5
Approach LOS		B			B			C				C
Timer - Assigned Phs	1	2		4	5	6		8				
Phs Duration (G+Y+Rc), s	5.2	25.4		14.0	12.5	18.1		6.8				
Change Period (Y+Rc), s	4.0	4.0		4.0	4.0	4.0		4.0				
Max Green Setting (Gmax), s	5.5	53.0		10.0	17.0	41.5		5.5				
Max Q Clear Time (g_c+I1), s	2.5	17.1		12.0	7.5	9.1		3.1				
Green Ext Time (p_c), s	0.0	4.4		0.0	1.0	3.4		0.0				
<b>Intersection Summary</b>												
HCM 6th Ctrl Delay			18.6									
HCM 6th LOS			B									

HCM 6th Signalized Intersection Summary  
 3: US 101 NB Off-Ramp & Shiloh Road

2028 Opening Year Alter. A Conditions  
 Timing Plan: A.M. PEAK



Movement	EBT	EBR	WBL	WBT	NBL	NBR
Lane Configurations	↑↑			↑	↘	↗
Traffic Volume (veh/h)	360	0	0	711	492	552
Future Volume (veh/h)	360	0	0	711	492	552
Initial Q (Qb), veh	0	0	0	0	0	0
Ped-Bike Adj(A_pbT)		1.00	1.00		1.00	1.00
Parking Bus, Adj	1.00	1.00	1.00	1.00	1.00	1.00
Work Zone On Approach	No			No	No	
Adj Sat Flow, veh/h/ln	1870	0	0	1870	1870	1870
Adj Flow Rate, veh/h	396	0	0	790	647	726
Peak Hour Factor	0.91	0.91	0.90	0.90	0.76	0.76
Percent Heavy Veh, %	2	0	0	2	2	2
Cap, veh/h	1639	0	0	862	742	1161
Arrive On Green	0.46	0.00	0.00	0.46	0.42	0.42
Sat Flow, veh/h	3741	0	0	1870	1781	2790
Grp Volume(v), veh/h	396	0	0	790	647	726
Grp Sat Flow(s),veh/h/ln	1777	0	0	1870	1781	1395
Q Serve(g_s), s	4.4	0.0	0.0	25.7	21.7	13.4
Cycle Q Clear(g_c), s	4.4	0.0	0.0	25.7	21.7	13.4
Prop In Lane		0.00	0.00		1.00	1.00
Lane Grp Cap(c), veh/h	1639	0	0	862	742	1161
V/C Ratio(X)	0.24	0.00	0.00	0.92	0.87	0.63
Avail Cap(c_a), veh/h	1797	0	0	946	846	1325
HCM Platoon Ratio	1.00	1.00	1.00	1.00	1.00	1.00
Upstream Filter(I)	1.00	0.00	0.00	1.00	1.00	1.00
Uniform Delay (d), s/veh	10.7	0.0	0.0	16.4	17.5	15.0
Incr Delay (d2), s/veh	0.1	0.0	0.0	12.7	9.0	0.7
Initial Q Delay(d3),s/veh	0.0	0.0	0.0	0.0	0.0	0.0
%ile BackOfQ(50%),veh/ln	1.4	0.0	0.0	11.8	9.7	3.9
Unsig. Movement Delay, s/veh						
LnGrp Delay(d),s/veh	10.7	0.0	0.0	29.1	26.5	15.8
LnGrp LOS	B	A	A	C	C	B
Approach Vol, veh/h	396			790	1373	
Approach Delay, s/veh	10.7			29.1	20.8	
Approach LOS	B			C	C	
Timer - Assigned Phs		2			6	8
Phs Duration (G+Y+Rc), s		34.1			34.1	31.2
Change Period (Y+Rc), s		4.0			4.0	4.0
Max Green Setting (Gmax), s		33.0			33.0	31.0
Max Q Clear Time (g_c+I1), s		6.4			27.7	23.7
Green Ext Time (p_c), s		2.5			2.4	3.4
<b>Intersection Summary</b>						
HCM 6th Ctrl Delay			21.8			
HCM 6th LOS			C			



HCM Signalized Intersection Capacity Analysis  
4: Shiloh Road & US 101 SB Off-Ramp

2028 Opening Year Alter. A Conditions

Timing Plan: A.M. PEAK



Movement	EBL	EBT	WBT	WBR	SBL	SBR
Lane Configurations		↑	↑		↘	↗
Traffic Volume (vph)	0	281	686	0	162	174
Future Volume (vph)	0	281	686	0	162	174
Ideal Flow (vphpl)	1900	1900	1900	1900	1900	1900
Total Lost time (s)		4.0	4.0		4.0	4.0
Lane Util. Factor		1.00	1.00		1.00	1.00
Frt		1.00	1.00		1.00	0.85
Flt Protected		1.00	1.00		0.95	1.00
Satd. Flow (prot)		1863	1863		1770	1583
Flt Permitted		1.00	1.00		0.95	1.00
Satd. Flow (perm)		1863	1863		1770	1583
Peak-hour factor, PHF	0.93	0.93	0.91	0.91	0.92	0.92
Adj. Flow (vph)	0	302	754	0	176	189
RTOR Reduction (vph)	0	0	0	0	0	145
Lane Group Flow (vph)	0	302	754	0	176	44
Turn Type		NA	NA		Perm	Perm
Protected Phases		2	6			
Permitted Phases					4	4
Actuated Green, G (s)		24.5	24.5		10.0	10.0
Effective Green, g (s)		24.5	24.5		10.0	10.0
Actuated g/C Ratio		0.58	0.58		0.24	0.24
Clearance Time (s)		4.0	4.0		4.0	4.0
Vehicle Extension (s)		3.0	3.0		3.0	3.0
Lane Grp Cap (vph)		1073	1073		416	372
v/s Ratio Prot		0.16	c0.40			
v/s Ratio Perm					c0.10	0.03
v/c Ratio		0.28	0.70		0.42	0.12
Uniform Delay, d1		4.6	6.4		13.8	12.8
Progression Factor		1.00	1.00		1.00	1.00
Incremental Delay, d2		0.1	2.1		0.7	0.1
Delay (s)		4.7	8.5		14.5	12.9
Level of Service		A	A		B	B
Approach Delay (s)		4.7	8.5		13.7	
Approach LOS		A	A		B	

Intersection Summary			
HCM 2000 Control Delay	9.0	HCM 2000 Level of Service	A
HCM 2000 Volume to Capacity ratio	0.62		
Actuated Cycle Length (s)	42.5	Sum of lost time (s)	8.0
Intersection Capacity Utilization	68.9%	ICU Level of Service	C
Analysis Period (min)	15		

c Critical Lane Group

Intersection						
Int Delay, s/veh	2.9					
Movement	EBT	EBR	WBL	WBT	NBL	NBR
Lane Configurations	↑↑		↘	↑	↘	↘
Traffic Vol, veh/h	604	25	202	633	8	138
Future Vol, veh/h	604	25	202	633	8	138
Conflicting Peds, #/hr	0	0	0	0	0	0
Sign Control	Free	Free	Free	Free	Stop	Stop
RT Channelized	-	None	-	None	-	None
Storage Length	-	-	68	-	0	0
Veh in Median Storage, #	0	-	-	0	0	-
Grade, %	0	-	-	0	0	-
Peak Hour Factor	96	96	87	87	84	84
Heavy Vehicles, %	2	2	2	2	2	2
Mvmt Flow	629	26	232	728	10	164

Major/Minor	Major1	Major2	Minor1		
Conflicting Flow All	0	0	655	0	1834 328
Stage 1	-	-	-	-	642 -
Stage 2	-	-	-	-	1192 -
Critical Hdwy	-	-	4.13	-	6.63 6.93
Critical Hdwy Stg 1	-	-	-	-	5.83 -
Critical Hdwy Stg 2	-	-	-	-	5.43 -
Follow-up Hdwy	-	-	2.219	-	3.519 3.319
Pot Cap-1 Maneuver	-	-	930	-	75 668
Stage 1	-	-	-	-	487 -
Stage 2	-	-	-	-	287 -
Platoon blocked, %	-	-	-	-	-
Mov Cap-1 Maneuver	-	-	930	-	56 668
Mov Cap-2 Maneuver	-	-	-	-	56 -
Stage 1	-	-	-	-	487 -
Stage 2	-	-	-	-	216 -



















Approach	EB	WB	NB
HCM Control Delay, s	0	2.5	15.9
HCM LOS			C

Minor Lane/Major Mvmt	NBLn1	NBLn2	EBT	EBR	WBL	WBT
Capacity (veh/h)	56	668	-	-	930	-
HCM Lane V/C Ratio	0.17	0.246	-	-	0.25	-
HCM Control Delay (s)	82	12.1	-	-	10.2	-
HCM Lane LOS	F	B	-	-	B	-
HCM 95th %tile Q(veh)	0.6	1	-	-	1	-

HCM Signalized Intersection Capacity Analysis  
6: Conde Lane & Shiloh Road

2028 Opening Year Alter. A Conditions

Timing Plan: A.M. PEAK

													
Movement	EBL	EBT	EBR	WBL	WBT	WBR	NBL	NBT	NBR	SBL	SBT	SBR	
Lane Configurations													
Traffic Volume (vph)	28	382	6	10	410	232	5	0	14	233	1	40	
Future Volume (vph)	28	382	6	10	410	232	5	0	14	233	1	40	
Ideal Flow (vphpl)	1900	1900	1900	1900	1900	1900	1900	1900	1900	1900	1900	1900	
Total Lost time (s)	4.0	4.0		4.0	4.0			4.0			4.0	4.0	
Lane Util. Factor	1.00	0.95		1.00	0.95			1.00			1.00	1.00	
Frt	1.00	1.00		1.00	0.95			0.90			1.00	0.85	
Flt Protected	0.95	1.00		0.95	1.00			0.99			0.95	1.00	
Satd. Flow (prot)	1770	3531		1770	3347			1656			1774	1583	
Flt Permitted	0.95	1.00		0.95	1.00			0.99			0.95	1.00	
Satd. Flow (perm)	1770	3531		1770	3347			1656			1774	1583	
Peak-hour factor, PHF	0.95	0.95	0.95	0.85	0.85	0.85	0.57	0.57	0.57	0.86	0.86	0.86	
Adj. Flow (vph)	29	402	6	12	482	273	9	0	25	271	1	47	
RTOR Reduction (vph)	0	1	0	0	74	0	0	32	0	0	0	0	
Lane Group Flow (vph)	29	407	0	12	681	0	0	2	0	0	272	47	
Turn Type	Prot	NA		Prot	NA		Split	NA		Split	NA	custom	
Protected Phases	5	2		1	6		7	7		4	4		
Permitted Phases												6	
Actuated Green, G (s)	2.2	19.7		1.1	18.6			2.7			12.8	18.6	
Effective Green, g (s)	2.2	19.7		1.1	18.6			2.7			12.8	18.6	
Actuated g/C Ratio	0.04	0.38		0.02	0.36			0.05			0.24	0.36	
Clearance Time (s)	4.0	4.0		4.0	4.0			4.0			4.0	4.0	
Vehicle Extension (s)	3.0	3.0		3.0	3.0			3.0			3.0	3.0	
Lane Grp Cap (vph)	74	1330		37	1190			85			434	562	
v/s Ratio Prot	c0.02	0.12		0.01	c0.20			c0.00			c0.15		
v/s Ratio Perm												0.03	
v/c Ratio	0.39	0.31		0.32	0.57			0.02			0.63	0.08	
Uniform Delay, d1	24.4	11.5		25.2	13.6			23.5			17.6	11.2	
Progression Factor	1.00	1.00		1.00	1.00			1.00			1.00	1.00	
Incremental Delay, d2	3.4	0.1		5.1	0.7			0.1			2.8	0.1	
Delay (s)	27.8	11.6		30.3	14.3			23.6			20.4	11.3	
Level of Service	C	B		C	B			C			C	B	
Approach Delay (s)		12.7			14.6			23.6			19.1		
Approach LOS		B			B			C			B		
<b>Intersection Summary</b>													
HCM 2000 Control Delay			15.2									HCM 2000 Level of Service	B
HCM 2000 Volume to Capacity ratio			0.54										
Actuated Cycle Length (s)			52.3									Sum of lost time (s)	16.0
Intersection Capacity Utilization			49.6%									ICU Level of Service	A
Analysis Period (min)			15										

c Critical Lane Group

Intersection												
Int Delay, s/veh	1.2											
Movement	EBL	EBT	EBR	WBL	WBT	WBR	NBL	NBT	NBR	SBL	SBT	SBR
Lane Configurations		↕	↕		↕		↕	↕			↕	
Traffic Vol, veh/h	9	306	47	0	167	0	33	0	0	1	0	18
Future Vol, veh/h	9	306	47	0	167	0	33	0	0	1	0	18
Conflicting Peds, #/hr	0	0	0	0	0	0	0	0	0	0	0	0
Sign Control	Free	Free	Free	Free	Free	Free	Stop	Stop	Stop	Stop	Stop	Stop
RT Channelized	-	-	None	-	-	None	-	-	None	-	-	None
Storage Length	-	-	150	-	-	-	0	-	-	-	-	-
Veh in Median Storage, #	-	0	-	-	0	-	-	0	-	-	0	-
Grade, %	-	0	-	-	0	-	-	0	-	-	0	-
Peak Hour Factor	91	91	91	85	85	85	100	100	100	71	71	71
Heavy Vehicles, %	2	2	2	2	2	2	2	2	2	2	2	2
Mvmt Flow	10	336	52	0	196	0	33	0	0	1	0	25

Major/Minor	Major1			Major2			Minor1			Minor2		
Conflicting Flow All	196	0	0	388	0	0	565	552	336	578	604	196
Stage 1	-	-	-	-	-	-	356	356	-	196	196	-
Stage 2	-	-	-	-	-	-	209	196	-	382	408	-
Critical Hdwy	4.12	-	-	4.12	-	-	7.12	6.52	6.22	7.12	6.52	6.22
Critical Hdwy Stg 1	-	-	-	-	-	-	6.12	5.52	-	6.12	5.52	-
Critical Hdwy Stg 2	-	-	-	-	-	-	6.12	5.52	-	6.12	5.52	-
Follow-up Hdwy	2.218	-	-	2.218	-	-	3.518	4.018	3.318	3.518	4.018	3.318
Pot Cap-1 Maneuver	1377	-	-	1170	-	-	436	442	706	427	412	845
Stage 1	-	-	-	-	-	-	661	629	-	806	739	-
Stage 2	-	-	-	-	-	-	793	739	-	640	597	-
Platoon blocked, %		-	-		-	-						
Mov Cap-1 Maneuver	1377	-	-	1170	-	-	420	438	706	424	408	845
Mov Cap-2 Maneuver	-	-	-	-	-	-	420	438	-	424	408	-
Stage 1	-	-	-	-	-	-	655	623	-	799	739	-
Stage 2	-	-	-	-	-	-	769	739	-	634	592	-

Approach	EB	WB	NB	SB
HCM Control Delay, s	0.2	0	14.3	9.6
HCM LOS			B	A

Minor Lane/Major Mvmt	NBLn1	NBLn2	EBL	EBT	EBR	WBL	WBT	WBR	SBLn1
Capacity (veh/h)	420	-	1377	-	-	1170	-	-	803
HCM Lane V/C Ratio	0.079	-	0.007	-	-	-	-	-	0.033
HCM Control Delay (s)	14.3	0	7.6	0	-	0	-	-	9.6
HCM Lane LOS	B	A	A	A	-	A	-	-	A
HCM 95th %tile Q(veh)	0.3	-	0	-	-	0	-	-	0.1

HCM 6th TWSC  
8: Old Redwood Hwy & Driveway 2

2028 Opening Year Alter. A Conditions  
Timing Plan: A.M. PEAK

Intersection												
Int Delay, s/veh	1.4											
Movement	EBL	EBT	EBR	WBL	WBT	WBR	NBL	NBT	NBR	SBL	SBT	SBR
Lane Configurations		↕		↕	↕			↕	↕	↕	↕	
Traffic Vol, veh/h	1	0	0	19	0	31	0	247	28	45	360	0
Future Vol, veh/h	1	0	0	19	0	31	0	247	28	45	360	0
Conflicting Peds, #/hr	0	0	0	0	0	0	0	0	1	1	0	0
Sign Control	Stop	Stop	Stop	Stop	Stop	Stop	Free	Free	Free	Free	Free	Free
RT Channelized	-	-	None	-	-	None	-	-	None	-	-	None
Storage Length	-	-	-	0	-	-	-	-	100	50	-	-
Veh in Median Storage, #	-	0	-	-	0	-	-	0	-	-	0	-
Grade, %	-	0	-	-	0	-	-	0	-	-	0	-
Peak Hour Factor	25	25	25	100	100	100	99	99	99	90	90	90
Heavy Vehicles, %	2	2	2	2	2	2	2	2	2	2	2	2
Mvmt Flow	4	0	0	19	0	31	0	249	28	50	400	0

Major/Minor	Minor2		Minor1		Major1		Major2					
Conflicting Flow All	779	778	400	750	750	250	400	0	0	278	0	0
Stage 1	500	500	-	250	250	-	-	-	-	-	-	-
Stage 2	279	278	-	500	500	-	-	-	-	-	-	-
Critical Hdwy	7.12	6.52	6.22	7.12	6.52	6.22	4.12	-	-	4.12	-	-
Critical Hdwy Stg 1	6.12	5.52	-	6.12	5.52	-	-	-	-	-	-	-
Critical Hdwy Stg 2	6.12	5.52	-	6.12	5.52	-	-	-	-	-	-	-
Follow-up Hdwy	3.518	4.018	3.318	3.518	4.018	3.318	2.218	-	-	2.218	-	-
Pot Cap-1 Maneuver	313	328	650	328	340	789	1159	-	-	1285	-	-
Stage 1	553	543	-	754	700	-	-	-	-	-	-	-
Stage 2	728	680	-	553	543	-	-	-	-	-	-	-
Platoon blocked, %								-	-	-	-	-
Mov Cap-1 Maneuver	292	315	650	318	326	788	1159	-	-	1284	-	-
Mov Cap-2 Maneuver	292	315	-	318	326	-	-	-	-	-	-	-
Stage 1	553	522	-	753	699	-	-	-	-	-	-	-
Stage 2	699	679	-	531	522	-	-	-	-	-	-	-

Approach	EB		WB		NB		SB	
HCM Control Delay, s	17.5		12.5		0		0.9	
HCM LOS	C		B					

Minor Lane/Major Mvmt	NBL	NBT	NBR	EBLn1	WBLn1	WBLn2	SBL	SBT	SBR
Capacity (veh/h)	1159	-	-	292	318	788	1284	-	-
HCM Lane V/C Ratio	-	-	-	0.014	0.06	0.039	0.039	-	-
HCM Control Delay (s)	0	-	-	17.5	17	9.8	7.9	-	-
HCM Lane LOS	A	-	-	C	C	A	A	-	-
HCM 95th %tile Q(veh)	0	-	-	0	0.2	0.1	0.1	-	-

Intersection						
Int Delay, s/veh	2.4					
Movement	EBT	EBR	WBL	WBT	NBL	NBR
Lane Configurations	↑	↗		↖	↖	↗
Traffic Vol, veh/h	159	145	14	59	101	10
Future Vol, veh/h	159	145	14	59	101	10
Conflicting Peds, #/hr	0	0	0	0	0	0
Sign Control	Free	Free	Free	Free	Stop	Stop
RT Channelized	-	None	-	None	-	None
Storage Length	-	200	-	-	0	0
Veh in Median Storage, #	0	-	-	0	0	-
Grade, %	0	-	-	0	0	-
Peak Hour Factor	85	85	81	81	100	100
Heavy Vehicles, %	2	2	2	2	2	2
Mvmt Flow	187	171	17	73	101	10

Major/Minor	Major1	Major2	Minor1		
Conflicting Flow All	0	0	358	0	294 187
Stage 1	-	-	-	-	187 -
Stage 2	-	-	-	-	107 -
Critical Hdwy	-	-	4.12	-	6.42 6.22
Critical Hdwy Stg 1	-	-	-	-	5.42 -
Critical Hdwy Stg 2	-	-	-	-	5.42 -
Follow-up Hdwy	-	-	2.218	-	3.518 3.318
Pot Cap-1 Maneuver	-	-	1201	-	697 855
Stage 1	-	-	-	-	845 -
Stage 2	-	-	-	-	917 -
Platoon blocked, %	-	-	-	-	-
Mov Cap-1 Maneuver	-	-	1201	-	687 855
Mov Cap-2 Maneuver	-	-	-	-	687 -
Stage 1	-	-	-	-	845 -
Stage 2	-	-	-	-	903 -

Approach	EB	WB	NB
HCM Control Delay, s	0	1.5	10.9
HCM LOS			B

Minor Lane/Major Mvmt	NBLn1	NBLn2	EBT	EBR	WBL	WBT
Capacity (veh/h)	687	855	-	-	1201	-
HCM Lane V/C Ratio	0.147	0.012	-	-	0.014	-
HCM Control Delay (s)	11.1	9.3	-	-	8	0
HCM Lane LOS	B	A	-	-	A	A
HCM 95th %tile Q(veh)	0.5	0	-	-	0	-

HCM 6th Signalized Intersection Summary

2028 Opening Year Alter. A Conditions

10: US 101 NB Off Ramp/Lakewood Drive & Old Redwood Highway

Timing Plan: A.M. PEAK



Movement	EBL	EBT	EBR	WBL	WBT	WBR	NBL	NBT	NBR	SBL	SBT	SBR
Lane Configurations	↔↔	↑			↑↑		↔	↔↔		↔↔		↔
Traffic Volume (veh/h)	173	198	0	0	520	170	258	252	90	134	0	608
Future Volume (veh/h)	173	198	0	0	520	170	258	252	90	134	0	608
Initial Q (Qb), veh	0	0	0	0	0	0	0	0	0	0	0	0
Ped-Bike Adj(A_pbT)	1.00		1.00	1.00		0.99	1.00		1.00	1.00		1.00
Parking Bus, Adj	1.00	1.00	1.00	1.00	1.00	1.00	1.00	1.00	1.00	1.00	1.00	1.00
Work Zone On Approach		No			No			No			No	
Adj Sat Flow, veh/h/ln	1870	1870	0	0	1870	1870	1870	1870	1870	1870	0	1870
Adj Flow Rate, veh/h	204	233	0	0	627	205	222	371	100	151	0	0
Peak Hour Factor	0.85	0.85	0.85	0.83	0.83	0.83	0.90	0.90	0.90	0.89	0.89	0.89
Percent Heavy Veh, %	2	2	0	0	2	2	2	2	2	2	0	2
Cap, veh/h	371	1187	0	0	1217	398	375	599	159	0	0	
Arrive On Green	0.11	0.63	0.00	0.00	0.46	0.46	0.21	0.21	0.21	0.00	0.00	0.00
Sat Flow, veh/h	3456	1870	0	0	2717	857	1781	2845	757		0	
Grp Volume(v), veh/h	204	233	0	0	424	408	222	242	229		0.0	
Grp Sat Flow(s),veh/h/ln	1728	1870	0	0	1777	1703	1781	1870	1732			
Q Serve(g_s), s	3.5	3.3	0.0	0.0	10.7	10.7	7.1	7.4	7.6			
Cycle Q Clear(g_c), s	3.5	3.3	0.0	0.0	10.7	10.7	7.1	7.4	7.6			
Prop In Lane	1.00		0.00	0.00		0.50	1.00		0.44			
Lane Grp Cap(c), veh/h	371	1187	0	0	825	790	375	394	365			
V/C Ratio(X)	0.55	0.20	0.00	0.00	0.51	0.52	0.59	0.62	0.63			
Avail Cap(c_a), veh/h	491	1187	0	0	825	790	816	856	793			
HCM Platoon Ratio	1.00	1.00	1.00	1.00	1.00	1.00	1.00	1.00	1.00			
Upstream Filter(I)	1.00	1.00	0.00	0.00	1.00	1.00	1.00	1.00	1.00			
Uniform Delay (d), s/veh	26.8	4.8	0.0	0.0	11.9	12.0	22.5	22.7	22.7			
Incr Delay (d2), s/veh	1.3	0.4	0.0	0.0	2.3	2.4	1.5	1.6	1.8			
Initial Q Delay(d3),s/veh	0.0	0.0	0.0	0.0	0.0	0.0	0.0	0.0	0.0			
%ile BackOfQ(50%),veh/ln	1.4	1.0	0.0	0.0	4.1	3.9	2.9	3.2	3.1			
Unsig. Movement Delay, s/veh												
LnGrp Delay(d),s/veh	28.1	5.2	0.0	0.0	14.2	14.4	24.0	24.2	24.5			
LnGrp LOS	C	A	A	A	B	B	C	C	C			
Approach Vol, veh/h		437			832			693				
Approach Delay, s/veh		15.9			14.3			24.3				
Approach LOS		B			B			C				
Timer - Assigned Phs		2			5	6		8				
Phs Duration (G+Y+Rc), s		45.3			10.8	34.5		18.0				
Change Period (Y+Rc), s		5.1			4.0	5.1		4.7				
Max Green Setting (Gmax), s		40.2			9.0	27.2		29.0				
Max Q Clear Time (g_c+I1), s		5.3			5.5	12.7		9.6				
Green Ext Time (p_c), s		1.4			0.2	4.6		3.4				

Intersection Summary

HCM 6th Ctrl Delay	18.2
HCM 6th LOS	B

Notes

User approved volume balancing among the lanes for turning movement.  
 Unsignalized Delay for [SBR] is excluded from calculations of the approach delay and intersection delay.

HCM 6th Signalized Intersection Summary

2028 Opening Year Alter. A Conditions

12: US 101 SB On Ramp/US 101 SB Off Ramp & Old Redwood Highway

Timing Plan: A.M. PEAK



Movement	EBL	EBT	EBR	WBL	WBT	WBR	NBL	NBT	NBR	SBL	SBT	SBR
Lane Configurations		↑↑	↗	↘	↑↑					↘	↕	
Traffic Volume (veh/h)	0	339	337	584	574	0	0	0	0	133	1	74
Future Volume (veh/h)	0	339	337	584	574	0	0	0	0	133	1	74
Initial Q (Qb), veh	0	0	0	0	0	0				0	0	0
Ped-Bike Adj(A_pbT)	1.00		0.98	1.00		1.00				1.00		1.00
Parking Bus, Adj	1.00	1.00	1.00	1.00	1.00	1.00				1.00	1.00	1.00
Work Zone On Approach		No			No						No	
Adj Sat Flow, veh/h/ln	0	1870	1870	1870	1870	0				1870	1870	1870
Adj Flow Rate, veh/h	0	368	366	656	645	0				128	51	0
Peak Hour Factor	0.92	0.92	0.92	0.89	0.89	0.89				0.81	0.81	0.81
Percent Heavy Veh, %	0	2	2	2	2	0				2	2	2
Cap, veh/h	0	1211	532	647	2680	0				219	230	
Arrive On Green	0.00	0.34	0.34	0.36	0.75	0.00				0.12	0.12	0.00
Sat Flow, veh/h	0	3647	1560	1781	3647	0				1781	1870	0
Grp Volume(v), veh/h	0	368	366	656	645	0				128	51	0
Grp Sat Flow(s),veh/h/ln	0	1777	1560	1781	1777	0				1781	1870	0
Q Serve(g_s), s	0.0	6.1	16.1	29.0	4.3	0.0				5.4	2.0	0.0
Cycle Q Clear(g_c), s	0.0	6.1	16.1	29.0	4.3	0.0				5.4	2.0	0.0
Prop In Lane	0.00		1.00	1.00		0.00				1.00		0.00
Lane Grp Cap(c), veh/h	0	1211	532	647	2680	0				219	230	
V/C Ratio(X)	0.00	0.30	0.69	1.01	0.24	0.00				0.58	0.22	
Avail Cap(c_a), veh/h	0	1211	532	647	2680	0				223	234	
HCM Platoon Ratio	1.00	1.00	1.00	1.00	1.00	1.00				1.00	1.00	1.00
Upstream Filter(I)	0.00	1.00	1.00	1.00	1.00	0.00				1.00	1.00	0.00
Uniform Delay (d), s/veh	0.0	19.3	22.7	25.4	2.9	0.0				33.1	31.6	0.0
Incr Delay (d2), s/veh	0.0	0.6	7.1	38.8	0.2	0.0				3.8	0.5	0.0
Initial Q Delay(d3),s/veh	0.0	0.0	0.0	0.0	0.0	0.0				0.0	0.0	0.0
%ile BackOfQ(50%),veh/ln	0.0	2.5	6.6	18.2	1.0	0.0				2.5	0.9	0.0
Unsig. Movement Delay, s/veh												
LnGrp Delay(d),s/veh	0.0	20.0	29.8	64.2	3.2	0.0				36.8	32.0	0.0
LnGrp LOS	A	B	C	F	A	A				D	C	
Approach Vol, veh/h		734			1301							179
Approach Delay, s/veh		24.9			33.9							35.5
Approach LOS		C			C							D
Timer - Assigned Phs		2			5	6				8		
Phs Duration (G+Y+Rc), s		65.3			33.0	32.3				14.5		
Change Period (Y+Rc), s		5.1			4.0	5.1				4.7		
Max Green Setting (Gmax), s		60.2			29.0	27.2				10.0		
Max Q Clear Time (g_c+I1), s		6.3			31.0	18.1				7.4		
Green Ext Time (p_c), s		5.0			0.0	2.6				0.1		

Intersection Summary

HCM 6th Ctrl Delay	31.1
HCM 6th LOS	C

Notes























- User approved volume balancing among the lanes for turning movement.
- User approved ignoring U-Turning movement.
- Unsignalized Delay for [SBR] is excluded from calculations of the approach delay and intersection delay.



HCM 6th Signalized Intersection Summary  
 1: Old Redwood Hwy & Shiloh Road

2028 Opening Year Alter. A Conditions





















Timing Plan: P.M. Peak

												
Movement	EBL	EBT	EBR	WBL	WBT	WBR	NBL	NBT	NBR	SBL	SBT	SBR
Lane Configurations												
Traffic Volume (veh/h)	290	531	308	42	394	57	255	396	24	83	283	183
Future Volume (veh/h)	290	531	308	42	394	57	255	396	24	83	283	183
Initial Q (Qb), veh	0	0	0	0	0	0	0	0	0	0	0	0
Ped-Bike Adj(A_pbT)	1.00		1.00	1.00		1.00	1.00		0.97	1.00		0.97
Parking Bus, Adj	1.00	1.00	1.00	1.00	1.00	1.00	1.00	1.00	1.00	1.00	1.00	1.00
Work Zone On Approach		No			No			No			No	
Adj Sat Flow, veh/h/ln	1870	1870	1870	1870	1870	1870	1870	1870	1870	1870	1870	1870
Adj Flow Rate, veh/h	299	547	318	46	433	63	274	426	26	89	304	197
Peak Hour Factor	0.97	0.97	0.97	0.91	0.91	0.91	0.93	0.93	0.93	0.93	0.93	0.93
Percent Heavy Veh, %	2	2	2	2	2	2	2	2	2	2	2	2
Cap, veh/h	460	483	409	50	473	444	219	498	411	91	363	299
Arrive On Green	0.26	0.26	0.26	0.28	0.28	0.28	0.12	0.27	0.27	0.05	0.19	0.19
Sat Flow, veh/h	1781	1870	1582	179	1683	1582	1781	1870	1544	1781	1870	1540
Grp Volume(v), veh/h	299	547	318	479	0	63	274	426	26	89	304	197
Grp Sat Flow(s),veh/h/ln	1781	1870	1582	1861	0	1582	1781	1870	1544	1781	1870	1540
Q Serve(g_s), s	17.7	30.5	22.0	29.4	0.0	3.5	14.5	25.6	1.5	5.9	18.5	14.0
Cycle Q Clear(g_c), s	17.7	30.5	22.0	29.4	0.0	3.5	14.5	25.6	1.5	5.9	18.5	14.0
Prop In Lane	1.00		1.00	0.10		1.00	1.00		1.00	1.00		1.00
Lane Grp Cap(c), veh/h	460	483	409	523	0	444	219	498	411	91	363	299
V/C Ratio(X)	0.65	1.13	0.78	0.92	0.00	0.14	1.25	0.86	0.06	0.98	0.84	0.66
Avail Cap(c_a), veh/h	460	483	409	599	0	509	219	689	569	91	554	457
HCM Platoon Ratio	1.00	1.00	1.00	1.00	1.00	1.00	1.00	1.00	1.00	1.00	1.00	1.00
Upstream Filter(I)	1.00	1.00	1.00	1.00	0.00	1.00	1.00	1.00	1.00	1.00	1.00	1.00
Uniform Delay (d), s/veh	39.0	43.8	40.7	41.1	0.0	31.8	51.8	41.2	32.3	56.0	45.8	44.0
Incr Delay (d2), s/veh	3.2	82.5	9.2	17.6	0.0	0.1	145.6	7.7	0.1	88.9	6.8	2.5
Initial Q Delay(d3),s/veh	0.0	0.0	0.0	0.0	0.0	0.0	0.0	0.0	0.0	0.0	0.0	0.0
%ile BackOfQ(50%),veh/ln	8.0	24.7	9.3	15.6	0.0	1.3	15.1	12.4	0.5	4.8	9.1	5.4
Unsig. Movement Delay, s/veh												
LnGrp Delay(d),s/veh	42.2	126.3	49.9	58.7	0.0	31.9	197.4	48.9	32.4	144.9	52.6	46.4
LnGrp LOS	D	F	D	E	A	C	F	D	C	F	D	D
Approach Vol, veh/h		1164			542			726			590	
Approach Delay, s/veh		83.8			55.6			104.3			64.5	
Approach LOS		F			E			F			E	
Timer - Assigned Phs		2	3	4		6	7	8				
Phs Duration (G+Y+Rc), s		35.0	18.0	27.4		37.7	9.5	35.9				
Change Period (Y+Rc), s		4.5	3.5	4.5		4.5	3.5	4.5				
Max Green Setting (Gmax), s		30.5	14.5	35.0		38.0	6.0	43.5				
Max Q Clear Time (g_c+I1), s		32.5	16.5	20.5		31.4	7.9	27.6				
Green Ext Time (p_c), s		0.0	0.0	2.0		1.7	0.0	2.2				
<b>Intersection Summary</b>												
HCM 6th Ctrl Delay				79.9								
HCM 6th LOS				E								

HCM 6th Signalized Intersection Summary  
2: Shiloh Road & Hembree Ln

2028 Opening Year Alter. A Conditions

Timing Plan: P.M. Peak

												
Movement	EBL	EBT	EBR	WBL	WBT	WBR	NBL	NBT	NBR	SBL	SBT	SBR
Lane Configurations												
Traffic Volume (veh/h)	700	968	44	24	695	165	65	11	15	194	11	565
Future Volume (veh/h)	700	968	44	24	695	165	65	11	15	194	11	565
Initial Q (Qb), veh	0	0	0	0	0	0	0	0	0	0	0	0
Ped-Bike Adj(A_pbT)	1.00		1.00	1.00		1.00	1.00		1.00	1.00		1.00
Parking Bus, Adj	1.00	1.00	1.00	1.00	1.00	1.00	1.00	1.00	1.00	1.00	1.00	1.00
Work Zone On Approach		No			No			No			No	
Adj Sat Flow, veh/h/ln	1870	1870	1870	1870	1870	1870	1870	1870	1870	1870	1870	1870
Adj Flow Rate, veh/h	745	1030	44	24	799	190	65	11	15	204	11	595
Peak Hour Factor	0.94	0.94	1.00	1.00	0.87	0.87	1.00	1.00	1.00	0.95	1.00	0.95
Percent Heavy Veh, %	2	2	2	2	2	2	2	2	2	2	2	2
Cap, veh/h	707	1084	46	46	1223	291	94	38	52	204	11	515
Arrive On Green	0.20	0.61	0.61	0.03	0.43	0.43	0.05	0.05	0.05	0.12	0.12	0.12
Sat Flow, veh/h	3456	1781	76	1781	2847	677	1781	717	978	1694	91	1585
Grp Volume(v), veh/h	745	0	1074	24	499	490	65	0	26	215	0	595
Grp Sat Flow(s),veh/h/ln	1728	0	1857	1781	1777	1747	1781	0	1694	1786	0	1585
Q Serve(g_s), s	17.0	0.0	44.6	1.1	18.5	18.5	3.0	0.0	1.2	10.0	0.0	10.0
Cycle Q Clear(g_c), s	17.0	0.0	44.6	1.1	18.5	18.5	3.0	0.0	1.2	10.0	0.0	10.0
Prop In Lane	1.00		0.04	1.00		0.39	1.00		0.58	0.95		1.00
Lane Grp Cap(c), veh/h	707	0	1130	46	763	751	94	0	89	215	0	515
V/C Ratio(X)	1.05	0.00	0.95	0.53	0.65	0.65	0.69	0.00	0.29	1.00	0.00	1.16
Avail Cap(c_a), veh/h	707	0	1184	118	887	873	118	0	112	215	0	515
HCM Platoon Ratio	1.00	1.00	1.00	1.00	1.00	1.00	1.00	1.00	1.00	1.00	1.00	1.00
Upstream Filter(I)	1.00	0.00	1.00	1.00	1.00	1.00	1.00	0.00	1.00	1.00	0.00	1.00
Uniform Delay (d), s/veh	33.0	0.0	15.1	40.0	18.8	18.8	38.7	0.0	37.9	36.5	0.0	28.0
Incr Delay (d2), s/veh	48.9	0.0	15.4	9.1	1.4	1.4	11.7	0.0	1.8	61.5	0.0	90.0
Initial Q Delay(d3),s/veh	0.0	0.0	0.0	0.0	0.0	0.0	0.0	0.0	0.0	0.0	0.0	0.0
%ile BackOfQ(50%),veh/ln	11.5	0.0	19.4	0.6	7.1	7.0	1.6	0.0	0.5	7.9	0.0	22.5
Unsig. Movement Delay, s/veh												
LnGrp Delay(d),s/veh	81.9	0.0	30.5	49.1	20.2	20.2	50.4	0.0	39.6	98.0	0.0	118.0
LnGrp LOS	F	A	C	D	C	C	D	A	D	F	A	F
Approach Vol, veh/h		1819			1013			91			810	
Approach Delay, s/veh		51.6			20.9			47.3			112.7	
Approach LOS		D			C			D			F	
Timer - Assigned Phs	1	2		4	5	6		8				
Phs Duration (G+Y+Rc), s	6.1	54.6		14.0	21.0	39.7		8.4				
Change Period (Y+Rc), s	4.0	4.0		4.0	4.0	4.0		4.0				
Max Green Setting (Gmax), s	5.5	53.0		10.0	17.0	41.5		5.5				
Max Q Clear Time (g_c+I1), s	3.1	46.6		12.0	19.0	20.5		5.0				
Green Ext Time (p_c), s	0.0	3.9		0.0	0.0	6.3		0.0				
<b>Intersection Summary</b>												
HCM 6th Ctrl Delay			56.4									
HCM 6th LOS			E									

HCM 6th Signalized Intersection Summary  
 3: US 101 NB Off-Ramp & Shiloh Road

2028 Opening Year Alter. A Conditions  
 Timing Plan: P.M. Peak



Movement	EBT	EBR	WBL	WBT	NBL	NBR
Lane Configurations	↑↑			↑	↘	↗
Traffic Volume (veh/h)	648	0	0	916	599	1069
Future Volume (veh/h)	648	0	0	916	599	1069
Initial Q (Qb), veh	0	0	0	0	0	0
Ped-Bike Adj(A_pbT)		1.00	1.00		1.00	1.00
Parking Bus, Adj	1.00	1.00	1.00	1.00	1.00	1.00
Work Zone On Approach	No			No	No	
Adj Sat Flow, veh/h/ln	1870	0	0	1870	1870	1870
Adj Flow Rate, veh/h	689	0	0	944	666	1188
Peak Hour Factor	0.94	0.94	0.97	0.97	0.90	0.90
Percent Heavy Veh, %	2	0	0	2	2	2
Cap, veh/h	1629	0	0	857	767	1201
Arrive On Green	0.46	0.00	0.00	0.46	0.43	0.43
Sat Flow, veh/h	3741	0	0	1870	1781	2790
Grp Volume(v), veh/h	689	0	0	944	666	1188
Grp Sat Flow(s),veh/h/ln	1777	0	0	1870	1781	1395
Q Serve(g_s), s	9.4	0.0	0.0	33.0	24.5	30.4
Cycle Q Clear(g_c), s	9.4	0.0	0.0	33.0	24.5	30.4
Prop In Lane		0.00	0.00		1.00	1.00
Lane Grp Cap(c), veh/h	1629	0	0	857	767	1201
V/C Ratio(X)	0.42	0.00	0.00	1.10	0.87	0.99
Avail Cap(c_a), veh/h	1629	0	0	857	767	1201
HCM Platoon Ratio	1.00	1.00	1.00	1.00	1.00	1.00
Upstream Filter(I)	1.00	0.00	0.00	1.00	1.00	1.00
Uniform Delay (d), s/veh	13.1	0.0	0.0	19.5	18.6	20.3
Incr Delay (d2), s/veh	0.2	0.0	0.0	62.3	10.4	23.3
Initial Q Delay(d3),s/veh	0.0	0.0	0.0	0.0	0.0	0.0
%ile BackOfQ(50%),veh/ln	3.2	0.0	0.0	26.7	11.3	12.7
Unsig. Movement Delay, s/veh						
LnGrp Delay(d),s/veh	13.3	0.0	0.0	81.8	29.1	43.6
LnGrp LOS	B	A	A	F	C	D
Approach Vol, veh/h	689			944	1854	
Approach Delay, s/veh	13.3			81.8	38.4	
Approach LOS	B			F	D	
Timer - Assigned Phs		2			6	8
Phs Duration (G+Y+Rc), s		37.0			37.0	35.0
Change Period (Y+Rc), s		4.0			4.0	4.0
Max Green Setting (Gmax), s		33.0			33.0	31.0
Max Q Clear Time (g_c+I1), s		11.4			35.0	32.4
Green Ext Time (p_c), s		4.5			0.0	0.0
<b>Intersection Summary</b>						
HCM 6th Ctrl Delay			45.2			
HCM 6th LOS			D			

HCM Signalized Intersection Capacity Analysis  
4: Shiloh Road & US 101 SB Off-Ramp

2028 Opening Year Alter. A Conditions  
Timing Plan: P.M. Peak

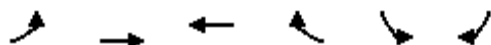

Movement	EBL	EBT	WBT	WBR	SBL	SBR
Lane Configurations		↑	↑		↘	↘
Traffic Volume (vph)	0	533	739	0	318	146
Future Volume (vph)	0	533	739	0	318	146
Ideal Flow (vphpl)	1900	1900	1900	1900	1900	1900
Total Lost time (s)		4.0	4.0		4.0	4.0
Lane Util. Factor		1.00	1.00		1.00	1.00
Frbp, ped/bikes		1.00	1.00		1.00	0.98
Flpb, ped/bikes		1.00	1.00		1.00	1.00
Frt		1.00	1.00		1.00	0.85
Flt Protected		1.00	1.00		0.95	1.00
Satd. Flow (prot)		1863	1863		1770	1549
Flt Permitted		1.00	1.00		0.95	1.00
Satd. Flow (perm)		1863	1863		1770	1549
Peak-hour factor, PHF	0.89	0.89	0.96	0.96	0.93	0.93
Adj. Flow (vph)	0	599	770	0	342	157
RTOR Reduction (vph)	0	0	0	0	0	105
Lane Group Flow (vph)	0	599	770	0	342	52
Confl. Peds. (#/hr)						1
Turn Type		NA	NA		Perm	Perm
Protected Phases		2	6			
Permitted Phases					4	4
Actuated Green, G (s)		27.1	27.1		17.4	17.4
Effective Green, g (s)		27.1	27.1		17.4	17.4
Actuated g/C Ratio		0.52	0.52		0.33	0.33
Clearance Time (s)		4.0	4.0		4.0	4.0
Vehicle Extension (s)		3.0	3.0		3.0	3.0
Lane Grp Cap (vph)		961	961		586	513
v/s Ratio Prot		0.32	c0.41			
v/s Ratio Perm					c0.19	0.03
v/c Ratio		0.62	0.80		0.58	0.10
Uniform Delay, d1		9.1	10.5		14.5	12.1
Progression Factor		1.00	1.00		1.00	1.00
Incremental Delay, d2		1.3	4.9		1.5	0.1
Delay (s)		10.3	15.3		16.0	12.2
Level of Service		B	B		B	B
Approach Delay (s)		10.3	15.3		14.8	
Approach LOS		B	B		B	
<b>Intersection Summary</b>						
HCM 2000 Control Delay			13.6		HCM 2000 Level of Service	B
HCM 2000 Volume to Capacity ratio			0.72			
Actuated Cycle Length (s)			52.5		Sum of lost time (s)	8.0
Intersection Capacity Utilization			134.7%		ICU Level of Service	H
Analysis Period (min)			15			
c Critical Lane Group						

Intersection						
Int Delay, s/veh	3.5					
Movement	EBT	EBR	WBL	WBT	NBL	NBR
Lane Configurations	↑↑		↘	↑	↘	↘
Traffic Vol, veh/h	1004	32	90	766	17	170
Future Vol, veh/h	1004	32	90	766	17	170
Conflicting Peds, #/hr	0	0	0	0	0	0
Sign Control	Free	Free	Free	Free	Stop	Stop
RT Channelized	-	None	-	None	-	None
Storage Length	-	-	68	-	0	0
Veh in Median Storage, #	0	-	-	0	0	-
Grade, %	0	-	-	0	0	-
Peak Hour Factor	89	89	92	92	89	89
Heavy Vehicles, %	2	2	2	2	2	2
Mvmt Flow	1128	36	98	833	19	191



















Major/Minor	Major1	Major2	Minor1		
Conflicting Flow All	0	0	1164	0	2175 582
Stage 1	-	-	-	-	1146 -
Stage 2	-	-	-	-	1029 -
Critical Hdwy	-	-	4.13	-	6.63 6.93
Critical Hdwy Stg 1	-	-	-	-	5.83 -
Critical Hdwy Stg 2	-	-	-	-	5.43 -
Follow-up Hdwy	-	-	2.219	-	3.519 3.319
Pot Cap-1 Maneuver	-	-	598	-	45 457
Stage 1	-	-	-	-	266 -
Stage 2	-	-	-	-	344 -
Platoon blocked, %	-	-	-	-	-
Mov Cap-1 Maneuver	-	-	598	-	38 457
Mov Cap-2 Maneuver	-	-	-	-	38 -
Stage 1	-	-	-	-	266 -
Stage 2	-	-	-	-	288 -

Approach	EB	WB	NB
HCM Control Delay, s	0	1.3	32.4
HCM LOS			D

Minor Lane/Major Mvmt	NBLn1	NBLn2	EBT	EBR	WBL	WBT
Capacity (veh/h)	38	457	-	-	598	-
HCM Lane V/C Ratio	0.503	0.418	-	-	0.164	-
HCM Control Delay (s)	172.1	18.4	-	-	12.2	-
HCM Lane LOS	F	C	-	-	B	-
HCM 95th %tile Q(veh)	1.7	2	-	-	0.6	-

HCM Signalized Intersection Capacity Analysis  
6: Conde Lane & Shiloh Road

2028 Opening Year Alter. A Conditions  
Timing Plan: P.M. Peak

													
Movement	EBL	EBT	EBR	WBL	WBT	WBR	NBL	NBT	NBR	SBL	SBT	SBR	
Lane Configurations													
Traffic Volume (vph)	79	570	2	8	544	329	6	3	19	338	0	44	
Future Volume (vph)	79	570	2	8	544	329	6	3	19	338	0	44	
Ideal Flow (vphp)	1900	1900	1900	1900	1900	1900	1900	1900	1900	1900	1900	1900	
Total Lost time (s)	4.0	4.0		4.0	4.0			4.0			4.0	4.0	
Lane Util. Factor	1.00	0.95		1.00	0.95			1.00			1.00	1.00	
Frbp, ped/bikes	1.00	1.00		1.00	0.99			1.00			1.00	1.00	
Flpb, ped/bikes	1.00	1.00		1.00	1.00			1.00			1.00	1.00	
Frt	1.00	1.00		1.00	0.94			0.91			1.00	0.85	
Flt Protected	0.95	1.00		0.95	1.00			0.99			0.95	1.00	
Satd. Flow (prot)	1770	3538		1770	3313			1676			1770	1583	
Flt Permitted	0.95	1.00		0.95	1.00			0.99			0.95	1.00	
Satd. Flow (perm)	1770	3538		1770	3313			1676			1770	1583	
Peak-hour factor, PHF	0.88	0.88	0.88	0.80	0.80	0.80	0.63	0.63	0.63	0.88	0.88	0.88	
Adj. Flow (vph)	90	648	2	10	680	411	10	5	30	384	0	50	
RTOR Reduction (vph)	0	0	0	0	74	0	0	28	0	0	0	0	
Lane Group Flow (vph)	90	650	0	10	1017	0	0	17	0	0	384	50	
Confl. Peds. (#/hr)	1					1							
Turn Type	Prot	NA		Prot	NA		Split	NA		Split	NA	custom	
Protected Phases	5	2		1	6		7	7		4	4		
Permitted Phases												6	
Actuated Green, G (s)	6.4	36.2		1.2	31.0			4.9			12.6	31.0	
Effective Green, g (s)	6.4	36.2		1.2	31.0			4.9			12.6	31.0	
Actuated g/C Ratio	0.09	0.51		0.02	0.44			0.07			0.18	0.44	
Clearance Time (s)	4.0	4.0		4.0	4.0			4.0			4.0	4.0	
Vehicle Extension (s)	3.0	3.0		3.0	3.0			3.0			3.0	3.0	
Lane Grp Cap (vph)	159	1806		29	1448			115			314	692	
v/s Ratio Prot	c0.05	0.18		0.01	c0.31			c0.01			c0.22		
v/s Ratio Perm												0.03	
v/c Ratio	0.57	0.36		0.34	0.70			0.15			1.22	0.07	
Uniform Delay, d1	30.9	10.4		34.5	16.2			31.0			29.2	11.6	
Progression Factor	1.00	1.00		1.00	1.00			1.00			1.00	1.00	
Incremental Delay, d2	4.6	0.1		7.0	1.6			0.6			125.5	0.0	
Delay (s)	35.5	10.5		41.5	17.8			31.6			154.6	11.6	
Level of Service	D	B		D	B			C			F	B	
Approach Delay (s)		13.6			18.0			31.6			138.1		
Approach LOS		B			B			C			F		
<b>Intersection Summary</b>													
HCM 2000 Control Delay			39.3									HCM 2000 Level of Service	D
HCM 2000 Volume to Capacity ratio			0.76										
Actuated Cycle Length (s)			70.9									Sum of lost time (s)	16.0
Intersection Capacity Utilization			67.7%									ICU Level of Service	C
Analysis Period (min)			15										
c Critical Lane Group													

HCM 6th TWSC  
7: Driveway 1/Gridley Drive & Shiloh Road

2028 Opening Year Alter. A Conditions  
Timing Plan: P.M. Peak

Intersection												
Int Delay, s/veh	3.4											
Movement	EBL	EBT	EBR	WBL	WBT	WBR	NBL	NBT	NBR	SBL	SBT	SBR
Lane Configurations		↔	↔		↔		↔	↔			↔	
Traffic Vol, veh/h	19	486	121	0	400	0	84	0	0	0	0	16
Future Vol, veh/h	19	486	121	0	400	0	84	0	0	0	0	16
Conflicting Peds, #/hr	1	0	0	0	0	0	0	0	0	0	0	0
Sign Control	Free	Free	Free	Free	Free	Free	Stop	Stop	Stop	Stop	Stop	Stop
RT Channelized	-	-	None	-	-	None	-	-	None	-	-	None
Storage Length	-	-	150	-	-	-	0	-	-	-	-	-
Veh in Median Storage, #	-	0	-	-	0	-	-	0	-	-	0	-
Grade, %	-	0	-	-	0	-	-	0	-	-	0	-
Peak Hour Factor	94	94	94	69	69	69	100	100	100	58	58	58
Heavy Vehicles, %	2	2	2	2	2	2	2	2	2	2	2	2
Mvmt Flow	20	517	129	0	580	0	84	0	0	0	0	28

Major/Minor	Major1			Major2			Minor1			Minor2		
Conflicting Flow All	581	0	0	646	0	0	1151	1138	517	1203	1267	581
Stage 1	-	-	-	-	-	-	557	557	-	581	581	-
Stage 2	-	-	-	-	-	-	594	581	-	622	686	-
Critical Hdwy	4.12	-	-	4.12	-	-	7.12	6.52	6.22	7.12	6.52	6.22
Critical Hdwy Stg 1	-	-	-	-	-	-	6.12	5.52	-	6.12	5.52	-
Critical Hdwy Stg 2	-	-	-	-	-	-	6.12	5.52	-	6.12	5.52	-
Follow-up Hdwy	2.218	-	-	2.218	-	-	3.518	4.018	3.318	3.518	4.018	3.318
Pot Cap-1 Maneuver	993	-	-	939	-	-	175	201	558	161	169	514
Stage 1	-	-	-	-	-	-	515	512	-	499	500	-
Stage 2	-	-	-	-	-	-	491	500	-	474	448	-
Platoon blocked, %		-	-		-	-						
Mov Cap-1 Maneuver	992	-	-	939	-	-	162	194	558	157	163	514
Mov Cap-2 Maneuver	-	-	-	-	-	-	162	194	-	157	163	-
Stage 1	-	-	-	-	-	-	499	496	-	483	500	-
Stage 2	-	-	-	-	-	-	465	500	-	459	434	-

Approach	EB	WB	NB	SB
HCM Control Delay, s	0.3	0	49	12.4
HCM LOS			E	B

Minor Lane/Major Mvmt	NBLn1	NBLn2	EBL	EBT	EBR	WBL	WBT	WBR	SBLn1
Capacity (veh/h)	162	-	992	-	-	939	-	-	514
HCM Lane V/C Ratio	0.519	-	0.02	-	-	-	-	-	0.054
HCM Control Delay (s)	49	0	8.7	0	-	0	-	-	12.4
HCM Lane LOS	E	A	A	A	-	A	-	-	B
HCM 95th %tile Q(veh)	2.6	-	0.1	-	-	0	-	-	0.2

HCM 6th TWSC  
8: Old Redwood Hwy & Driveway 2

2028 Opening Year Alter. A Conditions  
Timing Plan: P.M. Peak

Intersection												
Int Delay, s/veh	3.9											
Movement	EBL	EBT	EBR	WBL	WBT	WBR	NBL	NBT	NBR	SBL	SBT	SBR
Lane Configurations		↕		↕	↕			↕	↕	↕	↕	
Traffic Vol, veh/h	3	0	0	49	0	79	0	575	71	114	486	0
Future Vol, veh/h	3	0	0	49	0	79	0	575	71	114	486	0
Conflicting Peds, #/hr	0	0	0	0	0	0	0	0	0	0	0	0
Sign Control	Stop	Stop	Stop	Stop	Stop	Stop	Free	Free	Free	Free	Free	Free
RT Channelized	-	-	None	-	-	None	-	-	None	-	-	None
Storage Length	-	-	-	0	-	-	-	-	100	50	-	-
Veh in Median Storage, #	-	0	-	-	0	-	-	0	-	-	0	-
Grade, %	-	0	-	-	0	-	-	0	-	-	0	-
Peak Hour Factor	38	38	38	100	100	100	91	91	91	94	94	94
Heavy Vehicles, %	2	2	2	2	2	2	2	2	2	2	2	2
Mvmt Flow	8	0	0	49	0	79	0	632	78	121	517	0

Major/Minor	Minor2		Minor1		Major1		Major2					
Conflicting Flow All	1470	1469	517	1391	1391	632	517	0	0	710	0	0
Stage 1	759	759	-	632	632	-	-	-	-	-	-	-
Stage 2	711	710	-	759	759	-	-	-	-	-	-	-
Critical Hdwy	7.12	6.52	6.22	7.12	6.52	6.22	4.12	-	-	4.12	-	-
Critical Hdwy Stg 1	6.12	5.52	-	6.12	5.52	-	-	-	-	-	-	-
Critical Hdwy Stg 2	6.12	5.52	-	6.12	5.52	-	-	-	-	-	-	-
Follow-up Hdwy	3.518	4.018	3.318	3.518	4.018	3.318	2.218	-	-	2.218	-	-
Pot Cap-1 Maneuver	105	127	558	120	142	480	1049	-	-	889	-	-
Stage 1	399	415	-	468	474	-	-	-	-	-	-	-
Stage 2	424	437	-	399	415	-	-	-	-	-	-	-
Platoon blocked, %								-	-	-	-	-
Mov Cap-1 Maneuver	79	110	558	108	123	480	1049	-	-	889	-	-
Mov Cap-2 Maneuver	79	110	-	108	123	-	-	-	-	-	-	-
Stage 1	399	359	-	468	474	-	-	-	-	-	-	-
Stage 2	354	437	-	345	359	-	-	-	-	-	-	-

Approach	EB		WB		NB		SB	
HCM Control Delay, s	55.6		32.9		0		1.8	
HCM LOS	F		D					

Minor Lane/Major Mvmt	NBL	NBT	NBR	EBLn1	WBLn1	WBLn2	SBL	SBT	SBR
Capacity (veh/h)	1049	-	-	79	108	480	889	-	-
HCM Lane V/C Ratio	-	-	-	0.1	0.454	0.165	0.136	-	-
HCM Control Delay (s)	0	-	-	55.6	63.5	14	9.7	-	-
HCM Lane LOS	A	-	-	F	F	B	A	-	-
HCM 95th %tile Q(veh)	0	-	-	0.3	2	0.6	0.5	-	-



Intersection						
Int Delay, s/veh	4.7					
Movement	EBT	EBR	WBL	WBT	NBL	NBR
Lane Configurations	↑	↗		↖	↖	↗
Traffic Vol, veh/h	92	369	35	126	258	25
Future Vol, veh/h	92	369	35	126	258	25
Conflicting Peds, #/hr	0	0	0	0	0	0
Sign Control	Free	Free	Free	Free	Stop	Stop
RT Channelized	-	None	-	None	-	None
Storage Length	-	200	-	-	0	0
Veh in Median Storage, #	0	-	-	0	0	-
Grade, %	0	-	-	0	0	-
Peak Hour Factor	92	92	68	68	100	100
Heavy Vehicles, %	2	2	2	2	2	2
Mvmt Flow	100	401	51	185	258	25

Major/Minor	Major1	Major2	Minor1		
Conflicting Flow All	0	0	501	0	387
Stage 1	-	-	-	-	100
Stage 2	-	-	-	-	287
Critical Hdwy	-	-	4.12	-	6.42
Critical Hdwy Stg 1	-	-	-	-	5.42
Critical Hdwy Stg 2	-	-	-	-	5.42
Follow-up Hdwy	-	-	2.218	-	3.518
Pot Cap-1 Maneuver	-	-	1063	-	616
Stage 1	-	-	-	-	924
Stage 2	-	-	-	-	762
Platoon blocked, %	-	-	-	-	-
Mov Cap-1 Maneuver	-	-	1063	-	583
Mov Cap-2 Maneuver	-	-	-	-	583
Stage 1	-	-	-	-	924
Stage 2	-	-	-	-	722

Approach	EB	WB	NB
HCM Control Delay, s	0	1.9	15.4
HCM LOS			C

Minor Lane/Major Mvmt	NBLn1	NBLn2	EBT	EBR	WBL	WBT
Capacity (veh/h)	583	956	-	-	1063	-
HCM Lane V/C Ratio	0.443	0.026	-	-	0.048	-
HCM Control Delay (s)	16	8.9	-	-	8.6	0
HCM Lane LOS	C	A	-	-	A	A
HCM 95th %tile Q(veh)	2.3	0.1	-	-	0.2	-

HCM 6th Signalized Intersection Summary

2028 Opening Year Alter. A Conditions

10: US 101 NB Off Ramp/Lakewood Drive & Old Redwood Highway

Timing Plan: P.M. Peak



Movement	EBL	EBT	EBR	WBL	WBT	WBR	NBL	NBT	NBR	SBL	SBT	SBR
Lane Configurations	↔↔	↑			↑↑		↔	↔↔		↔↔		↔
Traffic Volume (veh/h)	297	470	0	0	615	219	569	469	286	284	0	657
Future Volume (veh/h)	297	470	0	0	615	219	569	469	286	284	0	657
Initial Q (Qb), veh	0	0	0	0	0	0	0	0	0	0	0	0
Ped-Bike Adj(A_pbT)	1.00		1.00	1.00		0.98	1.00		0.99	1.00		1.00
Parking Bus, Adj	1.00	1.00	1.00	1.00	1.00	1.00	1.00	1.00	1.00	1.00	1.00	1.00
Work Zone On Approach		No			No			No			No	
Adj Sat Flow, veh/h/ln	1870	1870	0	0	1870	1870	1870	1870	1870	1870	0	1870
Adj Flow Rate, veh/h	341	540	0	0	676	241	480	704	311	296	0	0
Peak Hour Factor	0.87	0.87	0.87	0.91	0.91	0.91	0.92	0.92	0.92	0.96	0.96	0.96
Percent Heavy Veh, %	2	2	0	0	2	2	2	2	2	2	0	2
Cap, veh/h	405	980	0	0	905	323	620	854	377	0	0	0
Arrive On Green	0.12	0.52	0.00	0.00	0.35	0.35	0.35	0.35	0.35	0.00	0.00	0.00
Sat Flow, veh/h	3456	1870	0	0	2645	910	1781	2453	1084		0	
Grp Volume(v), veh/h	341	540	0	0	471	446	480	537	478		0.0	
Grp Sat Flow(s),veh/h/ln	1728	1870	0	0	1777	1685	1781	1870	1666			
Q Serve(g_s), s	7.4	14.8	0.0	0.0	17.8	17.8	18.4	20.1	20.1			
Cycle Q Clear(g_c), s	7.4	14.8	0.0	0.0	17.8	17.8	18.4	20.1	20.1			
Prop In Lane	1.00		0.00	0.00		0.54	1.00		0.65			
Lane Grp Cap(c), veh/h	405	980	0	0	630	597	620	651	580			
V/C Ratio(X)	0.84	0.55	0.00	0.00	0.75	0.75	0.77	0.82	0.82			
Avail Cap(c_a), veh/h	405	980	0	0	630	597	673	707	630			
HCM Platoon Ratio	1.00	1.00	1.00	1.00	1.00	1.00	1.00	1.00	1.00			
Upstream Filter(I)	1.00	1.00	0.00	0.00	1.00	1.00	1.00	1.00	1.00			
Uniform Delay (d), s/veh	33.2	12.2	0.0	0.0	21.7	21.7	22.3	22.9	22.9			
Incr Delay (d2), s/veh	14.6	2.2	0.0	0.0	7.9	8.3	5.2	7.4	8.2			
Initial Q Delay(d3),s/veh	0.0	0.0	0.0	0.0	0.0	0.0	0.0	0.0	0.0			
%ile BackOfQ(50%),veh/ln	3.8	6.0	0.0	0.0	8.2	7.8	8.1	9.6	8.7			
Unsig. Movement Delay, s/veh												
LnGrp Delay(d),s/veh	47.8	14.4	0.0	0.0	29.6	30.0	27.5	30.2	31.1			
LnGrp LOS	D	B	A	A	C	C	C	C	C			
Approach Vol, veh/h		881			917			1495				
Approach Delay, s/veh		27.3			29.8			29.6				
Approach LOS		C			C			C				
Timer - Assigned Phs		2			5	6		8				
Phs Duration (G+Y+Rc), s		45.3			13.0	32.3		31.4				
Change Period (Y+Rc), s		5.1			4.0	5.1		4.7				
Max Green Setting (Gmax), s		40.2			9.0	27.2		29.0				
Max Q Clear Time (g_c+I1), s		16.8			9.4	19.8		22.1				
Green Ext Time (p_c), s		3.5			0.0	3.3		4.4				

Intersection Summary

HCM 6th Ctrl Delay	29.1
HCM 6th LOS	C

Notes

User approved volume balancing among the lanes for turning movement.  
 Unsignalized Delay for [SBR] is excluded from calculations of the approach delay and intersection delay.

HCM 6th Signalized Intersection Summary

2028 Opening Year Alter. A Conditions

12: US 101 SB On Ramp/US 101 SB Off Ramp & Old Redwood Highway

Timing Plan: P.M. Peak



Movement	EBL	EBT	EBR	WBL	WBT	WBR	NBL	NBT	NBR	SBL	SBT	SBR
Lane Configurations		↑↑	↗	↘	↑↑					↘	↕	
Traffic Volume (veh/h)	0	609	434	434	1166	0	0	0	0	261	0	147
Future Volume (veh/h)	0	609	434	434	1166	0	0	0	0	261	0	147
Initial Q (Qb), veh	0	0	0	0	0	0				0	0	0
Ped-Bike Adj(A_pbT)	1.00		0.98	1.00		1.00				1.00		1.00
Parking Bus, Adj	1.00	1.00	1.00	1.00	1.00	1.00				1.00	1.00	1.00
Work Zone On Approach		No			No						No	
Adj Sat Flow, veh/h/ln	0	1870	1870	1870	1870	0				1870	1870	1870
Adj Flow Rate, veh/h	0	648	462	488	1310	0				246	96	0
Peak Hour Factor	0.94	0.94	0.94	0.89	0.89	0.89				0.83	0.83	0.83
Percent Heavy Veh, %	0	2	2	2	2	0				2	2	2
Cap, veh/h	0	1416	622	458	2533	0				262	275	
Arrive On Green	0.00	0.40	0.40	0.26	0.71	0.00				0.15	0.15	0.00
Sat Flow, veh/h	0	3647	1560	1781	3647	0				1781	1870	0
Grp Volume(v), veh/h	0	648	462	488	1310	0				246	96	0
Grp Sat Flow(s),veh/h/ln	0	1777	1560	1781	1777	0				1781	1870	0
Q Serve(g_s), s	0.0	9.4	17.7	18.0	11.7	0.0				9.6	3.2	0.0
Cycle Q Clear(g_c), s	0.0	9.4	17.7	18.0	11.7	0.0				9.6	3.2	0.0
Prop In Lane	0.00		1.00	1.00		0.00				1.00		0.00
Lane Grp Cap(c), veh/h	0	1416	622	458	2533	0				262	275	
V/C Ratio(X)	0.00	0.46	0.74	1.07	0.52	0.00				0.94	0.35	
Avail Cap(c_a), veh/h	0	1416	622	458	2533	0				262	275	
HCM Platoon Ratio	1.00	1.00	1.00	1.00	1.00	1.00				1.00	1.00	1.00
Upstream Filter(I)	0.00	1.00	1.00	1.00	1.00	0.00				1.00	1.00	0.00
Uniform Delay (d), s/veh	0.0	15.5	18.0	26.0	4.6	0.0				29.5	26.8	0.0
Incr Delay (d2), s/veh	0.0	1.1	7.8	60.5	0.8	0.0				39.2	0.8	0.0
Initial Q Delay(d3),s/veh	0.0	0.0	0.0	0.0	0.0	0.0				0.0	0.0	0.0
%ile BackOfQ(50%),veh/ln	0.0	3.6	7.0	14.7	2.8	0.0				6.8	1.4	0.0
Unsig. Movement Delay, s/veh												
LnGrp Delay(d),s/veh	0.0	16.6	25.8	86.5	5.3	0.0				68.7	27.6	0.0
LnGrp LOS	A	B	C	F	A	A				E	C	
Approach Vol, veh/h		1110			1798						342	
Approach Delay, s/veh		20.4			27.4						57.2	
Approach LOS		C			C						E	
Timer - Assigned Phs		2			5	6		8				
Phs Duration (G+Y+Rc), s		55.0			22.0	33.0		15.0				
Change Period (Y+Rc), s		5.1			4.0	5.1		4.7				
Max Green Setting (Gmax), s		49.9			18.0	27.9		10.3				
Max Q Clear Time (g_c+I1), s		13.7			20.0	19.7		11.6				
Green Ext Time (p_c), s		12.5			0.0	3.8		0.0				

Intersection Summary

HCM 6th Ctrl Delay	28.1
HCM 6th LOS	C























Notes

- User approved volume balancing among the lanes for turning movement.
- User approved ignoring U-Turning movement.
- Unsignalized Delay for [SBR] is excluded from calculations of the approach delay and intersection delay.

HCM 6th Signalized Intersection Summary  
 1: Old Redwood Hwy & Shiloh Road

2028 Opening Year Alter. A Conditions

























Timing Plan: Saturday Midday Peak

												
Movement	EBL	EBT	EBR	WBL	WBT	WBR	NBL	NBT	NBR	SBL	SBT	SBR
Lane Configurations												
Traffic Volume (veh/h)	156	484	289	24	500	71	296	280	27	76	229	239
Future Volume (veh/h)	156	484	289	24	500	71	296	280	27	76	229	239
Initial Q (Qb), veh	0	0	0	0	0	0	0	0	0	0	0	0
Ped-Bike Adj(A_pbT)	1.00		0.97	1.00		1.00	1.00		0.98	1.00		0.97
Parking Bus, Adj	1.00	1.00	1.00	1.00	1.00	1.00	1.00	1.00	1.00	1.00	1.00	1.00
Work Zone On Approach		No			No			No			No	
Adj Sat Flow, veh/h/ln	1870	1870	1870	1870	1870	1870	1870	1870	1870	1870	1870	1870
Adj Flow Rate, veh/h	175	544	325	28	581	83	318	301	29	84	252	263
Peak Hour Factor	0.89	0.89	0.89	0.86	0.86	0.86	0.93	0.93	0.93	0.91	0.91	0.91
Percent Heavy Veh, %	2	2	2	2	2	2	2	2	2	2	2	2
Cap, veh/h	436	458	377	26	543	484	200	496	411	79	368	303
Arrive On Green	0.25	0.25	0.25	0.31	0.31	0.31	0.11	0.26	0.26	0.04	0.20	0.20
Sat Flow, veh/h	1781	1870	1538	86	1780	1585	1781	1870	1551	1781	1870	1538
Grp Volume(v), veh/h	175	544	325	609	0	83	318	301	29	84	252	263
Grp Sat Flow(s),veh/h/ln	1781	1870	1538	1866	0	1585	1781	1870	1551	1781	1870	1538
Q Serve(g_s), s	10.2	30.5	25.2	38.0	0.0	4.8	14.0	17.5	1.7	5.5	15.6	20.6
Cycle Q Clear(g_c), s	10.2	30.5	25.2	38.0	0.0	4.8	14.0	17.5	1.7	5.5	15.6	20.6
Prop In Lane	1.00		1.00	0.05		1.00	1.00		1.00	1.00		1.00
Lane Grp Cap(c), veh/h	436	458	377	570	0	484	200	496	411	79	368	303
V/C Ratio(X)	0.40	1.19	0.86	1.07	0.00	0.17	1.59	0.61	0.07	1.07	0.69	0.87
Avail Cap(c_a), veh/h	436	458	377	570	0	484	200	654	542	79	526	433
HCM Platoon Ratio	1.00	1.00	1.00	1.00	1.00	1.00	1.00	1.00	1.00	1.00	1.00	1.00
Upstream Filter(I)	1.00	1.00	1.00	1.00	0.00	1.00	1.00	1.00	1.00	1.00	1.00	1.00
Uniform Delay (d), s/veh	39.3	47.0	45.0	43.2	0.0	31.7	55.2	40.1	34.3	59.5	46.4	48.4
Incr Delay (d2), s/veh	0.6	104.3	18.1	57.5	0.0	0.2	286.7	1.2	0.1	121.0	2.3	12.6
Initial Q Delay(d3),s/veh	0.0	0.0	0.0	0.0	0.0	0.0	0.0	0.0	0.0	0.0	0.0	0.0
%ile BackOfQ(50%),veh/ln	4.5	27.1	11.2	26.1	0.0	1.8	22.1	8.0	0.7	5.1	7.3	8.8
Unsig. Movement Delay, s/veh												
LnGrp Delay(d),s/veh	39.9	151.3	63.1	100.8	0.0	31.9	341.9	41.3	34.3	180.5	48.7	61.0
LnGrp LOS	D	F	E	F	A	C	F	D	C	F	D	E
Approach Vol, veh/h		1044			692			648			599	
Approach Delay, s/veh		105.2			92.5			188.5			72.6	
Approach LOS		F			F			F			E	
Timer - Assigned Phs		2	3	4		6	7	8				
Phs Duration (G+Y+Rc), s		35.0	18.0	29.0		42.5	9.5	37.5				
Change Period (Y+Rc), s		4.5	4.0	4.5		4.5	4.0	4.5				
Max Green Setting (Gmax), s		30.5	14.0	35.0		38.0	5.5	43.5				
Max Q Clear Time (g_c+I1), s		32.5	16.0	22.6		40.0	7.5	19.5				
Green Ext Time (p_c), s		0.0	0.0	1.9		0.0	0.0	1.6				
<b>Intersection Summary</b>												
HCM 6th Ctrl Delay				113.8								
HCM 6th LOS				F								

HCM 6th Signalized Intersection Summary  
 2: Shiloh Road & Hembree Ln

2028 Opening Year Alter. A Conditions

Timing Plan: Saturday Midday Peak

												
Movement	EBL	EBT	EBR	WBL	WBT	WBR	NBL	NBT	NBR	SBL	SBT	SBR
Lane Configurations	 			 	 						 	
Traffic Volume (veh/h)	708	852	44	24	792	185	65	11	15	182	11	666
Future Volume (veh/h)	708	852	44	24	792	185	65	11	15	182	11	666
Initial Q (Qb), veh	0	0	0	0	0	0	0	0	0	0	0	0
Ped-Bike Adj(A_pbT)	1.00		1.00	1.00		1.00	1.00		1.00	1.00		1.00
Parking Bus, Adj	1.00	1.00	1.00	1.00	1.00	1.00	1.00	1.00	1.00	1.00	1.00	1.00
Work Zone On Approach		No			No			No			No	
Adj Sat Flow, veh/h/ln	1870	1870	1870	1870	1870	1870	1870	1870	1870	1870	1870	1870
Adj Flow Rate, veh/h	753	906	44	24	825	193	65	11	15	200	11	732
Peak Hour Factor	0.94	0.94	1.00	1.00	0.96	0.96	1.00	1.00	1.00	0.91	1.00	0.91
Percent Heavy Veh, %	2	2	2	2	2	2	2	2	2	2	2	2
Cap, veh/h	783	1010	49	47	1059	248	101	41	55	225	12	570
Arrive On Green	0.23	0.57	0.57	0.03	0.37	0.37	0.06	0.06	0.06	0.13	0.13	0.13
Sat Flow, veh/h	3456	1769	86	1781	2858	668	1781	717	978	1693	93	1585
Grp Volume(v), veh/h	753	0	950	24	513	505	65	0	26	211	0	732
Grp Sat Flow(s),veh/h/ln	1728	0	1855	1781	1777	1749	1781	0	1694	1786	0	1585
Q Serve(g_s), s	16.2	0.0	33.8	1.0	19.2	19.2	2.7	0.0	1.1	8.7	0.0	10.0
Cycle Q Clear(g_c), s	16.2	0.0	33.8	1.0	19.2	19.2	2.7	0.0	1.1	8.7	0.0	10.0
Prop In Lane	1.00		0.05	1.00		0.38	1.00		0.58	0.95		1.00
Lane Grp Cap(c), veh/h	783	0	1059	47	658	648	101	0	96	238	0	570
V/C Ratio(X)	0.96	0.00	0.90	0.51	0.78	0.78	0.64	0.00	0.27	0.89	0.00	1.28
Avail Cap(c_a), veh/h	783	0	1310	131	982	967	131	0	124	238	0	570
HCM Platoon Ratio	1.00	1.00	1.00	1.00	1.00	1.00	1.00	1.00	1.00	1.00	1.00	1.00
Upstream Filter(I)	1.00	0.00	1.00	1.00	1.00	1.00	1.00	0.00	1.00	1.00	0.00	1.00
Uniform Delay (d), s/veh	28.7	0.0	14.2	36.1	20.9	20.9	34.7	0.0	33.9	32.0	0.0	24.0
Incr Delay (d2), s/veh	23.3	0.0	7.3	8.5	2.4	2.4	6.7	0.0	1.5	30.5	0.0	140.8
Initial Q Delay(d3),s/veh	0.0	0.0	0.0	0.0	0.0	0.0	0.0	0.0	0.0	0.0	0.0	0.0
%ile BackOfQ(50%),veh/ln	8.7	0.0	13.1	0.5	7.5	7.4	1.3	0.0	0.5	5.6	0.0	31.6
Unsig. Movement Delay, s/veh												
LnGrp Delay(d),s/veh	52.0	0.0	21.5	44.5	23.3	23.3	41.4	0.0	35.4	62.5	0.0	164.8
LnGrp LOS	D	A	C	D	C	C	D	A	D	E	A	F
Approach Vol, veh/h		1703			1042			91				943
Approach Delay, s/veh		35.0			23.8			39.7				141.9
Approach LOS		C			C			D				F
Timer - Assigned Phs	1	2		4	5	6		8				
Phs Duration (G+Y+Rc), s	6.0	46.9		14.0	21.0	31.8		8.3				
Change Period (Y+Rc), s	4.0	4.0		4.0	4.0	4.0		4.0				
Max Green Setting (Gmax), s	5.5	53.0		10.0	17.0	41.5		5.5				
Max Q Clear Time (g_c+I1), s	3.0	35.8		12.0	18.2	21.2		4.7				
Green Ext Time (p_c), s	0.0	6.6		0.0	0.0	6.4		0.0				
<b>Intersection Summary</b>												
HCM 6th Ctrl Delay				58.7								
HCM 6th LOS				E								

HCM 6th Signalized Intersection Summary  
 3: US 101 NB Off-Ramp & Shiloh Road

2028 Opening Year Alter. A Conditions  
 Timing Plan: Saturday Midday Peak



Movement	EBT	EBR	WBL	WBT	NBL	NBR
Lane Configurations	↑↑			↑	↘	↗
Traffic Volume (veh/h)	639	0	0	1115	401	954
Future Volume (veh/h)	639	0	0	1115	401	954
Initial Q (Qb), veh	0	0	0	0	0	0
Ped-Bike Adj(A_pbT)		1.00	1.00		1.00	1.00
Parking Bus, Adj	1.00	1.00	1.00	1.00	1.00	1.00
Work Zone On Approach	No			No	No	
Adj Sat Flow, veh/h/ln	1870	0	0	1870	1870	1870
Adj Flow Rate, veh/h	639	0	0	1115	401	954
Peak Hour Factor	1.00	1.00	1.00	1.00	1.00	1.00
Percent Heavy Veh, %	2	0	0	2	2	2
Cap, veh/h	1825	0	0	961	663	1038
Arrive On Green	0.51	0.00	0.00	0.51	0.37	0.37
Sat Flow, veh/h	3741	0	0	1870	1781	2790
Grp Volume(v), veh/h	639	0	0	1115	401	954
Grp Sat Flow(s),veh/h/ln	1777	0	0	1870	1781	1395
Q Serve(g_s), s	8.4	0.0	0.0	40.5	14.4	25.7
Cycle Q Clear(g_c), s	8.4	0.0	0.0	40.5	14.4	25.7
Prop In Lane		0.00	0.00		1.00	1.00
Lane Grp Cap(c), veh/h	1825	0	0	961	663	1038
V/C Ratio(X)	0.35	0.00	0.00	1.16	0.60	0.92
Avail Cap(c_a), veh/h	1825	0	0	961	689	1079
HCM Platoon Ratio	1.00	1.00	1.00	1.00	1.00	1.00
Upstream Filter(I)	1.00	0.00	0.00	1.00	1.00	1.00
Uniform Delay (d), s/veh	11.4	0.0	0.0	19.2	20.1	23.6
Incr Delay (d2), s/veh	0.1	0.0	0.0	84.0	1.4	12.1
Initial Q Delay(d3),s/veh	0.0	0.0	0.0	0.0	0.0	0.0
%ile BackOfQ(50%),veh/ln	2.9	0.0	0.0	36.8	5.9	9.6
Unsig. Movement Delay, s/veh						
LnGrp Delay(d),s/veh	11.5	0.0	0.0	103.1	21.5	35.7
LnGrp LOS	B	A	A	F	C	D
Approach Vol, veh/h	639			1115	1355	
Approach Delay, s/veh	11.5			103.1	31.5	
Approach LOS	B			F	C	
Timer - Assigned Phs		2			6	8
Phs Duration (G+Y+Rc), s		45.0			45.0	33.9
Change Period (Y+Rc), s		4.5			4.5	4.5
Max Green Setting (Gmax), s		40.5			40.5	30.5
Max Q Clear Time (g_c+I1), s		10.4			42.5	27.7
Green Ext Time (p_c), s		4.4			0.0	1.6
<b>Intersection Summary</b>						
HCM 6th Ctrl Delay			53.1			
HCM 6th LOS			D			

HCM Signalized Intersection Capacity Analysis  
4: Shiloh Road & US 101 SB Off-Ramp

2028 Opening Year Alter. A Conditions  
Timing Plan: Saturday Midday Peak



Movement	EBL	EBT	WBT	WBR	SBL	SBR
Lane Configurations		↑	↑		↘	↗
Traffic Volume (vph)	0	351	634	0	376	174
Future Volume (vph)	0	351	634	0	376	174
Ideal Flow (vphpl)	1900	1900	1900	1900	1900	1900
Total Lost time (s)		4.5	4.5		4.5	4.5
Lane Util. Factor		1.00	1.00		1.00	1.00
Frbp, ped/bikes		1.00	1.00		1.00	1.00
Flpb, ped/bikes		1.00	1.00		1.00	1.00
Frt		1.00	1.00		1.00	0.85
Flt Protected		1.00	1.00		0.95	1.00
Satd. Flow (prot)		1863	1863		1770	1583
Flt Permitted		1.00	1.00		0.95	1.00
Satd. Flow (perm)		1863	1863		1770	1583
Peak-hour factor, PHF	0.96	0.96	0.96	0.96	0.68	0.68
Adj. Flow (vph)	0	366	660	0	553	256
RTOR Reduction (vph)	0	0	0	0	0	166
Lane Group Flow (vph)	0	366	660	0	553	90
Confl. Bikes (#/hr)				2		
Turn Type		NA	NA		Perm	Perm
Protected Phases		2	6			
Permitted Phases					4	4
Actuated Green, G (s)		22.2	22.2		16.8	16.8
Effective Green, g (s)		22.2	22.2		16.8	16.8
Actuated g/C Ratio		0.46	0.46		0.35	0.35
Clearance Time (s)		4.5	4.5		4.5	4.5
Vehicle Extension (s)		3.0	3.0		3.0	3.0
Lane Grp Cap (vph)		861	861		619	554
v/s Ratio Prot		0.20	c0.35			
v/s Ratio Perm					c0.31	0.06
v/c Ratio		0.43	0.77		0.89	0.16
Uniform Delay, d1		8.6	10.7		14.8	10.7
Progression Factor		1.00	1.00		1.00	1.00
Incremental Delay, d2		0.3	4.1		15.2	0.1
Delay (s)		9.0	14.9		30.0	10.9
Level of Service		A	B		C	B
Approach Delay (s)		9.0	14.9		23.9	
Approach LOS		A	B		C	
<b>Intersection Summary</b>						
HCM 2000 Control Delay			17.7		HCM 2000 Level of Service	B
HCM 2000 Volume to Capacity ratio			0.82			
Actuated Cycle Length (s)			48.0		Sum of lost time (s)	9.0
Intersection Capacity Utilization			133.9%		ICU Level of Service	H
Analysis Period (min)			15			
c Critical Lane Group						

Intersection						
Int Delay, s/veh	2.3					
Movement	EBT	EBR	WBL	WBT	NBL	NBR
Lane Configurations	↑↑		↘	↑	↘	↘
Traffic Vol, veh/h	645	23	92	710	18	89
Future Vol, veh/h	645	23	92	710	18	89
Conflicting Peds, #/hr	0	0	0	0	1	0
Sign Control	Free	Free	Free	Free	Stop	Stop
RT Channelized	-	None	-	None	-	None
Storage Length	-	-	68	-	0	0
Veh in Median Storage, #	0	-	-	0	0	-
Grade, %	0	-	-	0	0	-
Peak Hour Factor	92	92	87	87	78	78
Heavy Vehicles, %	2	2	2	2	2	2
Mvmt Flow	701	25	106	816	23	114

Major/Minor	Major1	Major2	Minor1		
Conflicting Flow All	0	0	726	0	1743 363
Stage 1	-	-	-	-	714 -
Stage 2	-	-	-	-	1029 -
Critical Hdwy	-	-	4.13	-	6.63 6.93
Critical Hdwy Stg 1	-	-	-	-	5.83 -
Critical Hdwy Stg 2	-	-	-	-	5.43 -
Follow-up Hdwy	-	-	2.219	-	3.519 3.319
Pot Cap-1 Maneuver	-	-	875	-	86 635
Stage 1	-	-	-	-	447 -
Stage 2	-	-	-	-	344 -
Platoon blocked, %	-	-	-	-	-
Mov Cap-1 Maneuver	-	-	875	-	76 635
Mov Cap-2 Maneuver	-	-	-	-	76 -
Stage 1	-	-	-	-	447 -
Stage 2	-	-	-	-	302 -

Approach	EB	WB	NB
HCM Control Delay, s	0	1.1	22
HCM LOS			C

Minor Lane/Major Mvmt	NBLn1	NBLn2	EBT	EBR	WBL	WBT
Capacity (veh/h)	76	635	-	-	875	-
HCM Lane V/C Ratio	0.304	0.18	-	-	0.121	-
HCM Control Delay (s)	71.8	11.9	-	-	9.7	-
HCM Lane LOS	F	B	-	-	A	-
HCM 95th %tile Q(veh)	1.1	0.7	-	-	0.4	-



HCM Signalized Intersection Capacity Analysis  
6: Conde Lane & Shiloh Road

2028 Opening Year Alter. A Conditions  
Timing Plan: Saturday Midday Peak

Movement	EBL	EBT	EBR	WBL	WBT	WBR	NBL	NBT	NBR	SBL	SBT	SBR	
Lane Configurations													
Traffic Volume (vph)	33	435	1	10	482	232	1	0	7	224	0	32	
Future Volume (vph)	33	435	1	10	482	232	1	0	7	224	0	32	
Ideal Flow (vphp)	1900	1900	1900	1900	1900	1900	1900	1900	1900	1900	1900	1900	
Total Lost time (s)	4.5	4.5		4.5	4.5			4.5			4.5	4.5	
Lane Util. Factor	1.00	0.95		1.00	0.95			1.00			1.00	1.00	
Frbp, ped/bikes	1.00	1.00		1.00	0.99			1.00			1.00	1.00	
Flpb, ped/bikes	1.00	1.00		1.00	1.00			1.00			1.00	1.00	
Frt	1.00	1.00		1.00	0.95			0.88			1.00	0.85	
Flt Protected	0.95	1.00		0.95	1.00			0.99			0.95	1.00	
Satd. Flow (prot)	1770	3538		1770	3343			1636			1770	1583	
Flt Permitted	0.95	1.00		0.95	1.00			0.99			0.95	1.00	
Satd. Flow (perm)	1770	3538		1770	3343			1636			1770	1583	
Peak-hour factor, PHF	0.96	0.96	0.96	0.91	0.91	0.91	0.58	0.58	0.58	0.78	0.78	0.78	
Adj. Flow (vph)	34	453	1	11	530	255	2	0	12	287	0	41	
RTOR Reduction (vph)	0	0	0	0	53	0	0	14	0	0	0	0	
Lane Group Flow (vph)	34	454	0	11	732	0	0	0	0	0	287	41	
Confl. Bikes (#/hr)							2						
Turn Type	Prot	NA		Prot	NA		Split	NA		Split	NA	custom	
Protected Phases	5	2		1	6		7	7		4	4		
Permitted Phases												6	
Actuated Green, G (s)	2.4	20.1		1.0	18.7			1.2			12.3	18.7	
Effective Green, g (s)	2.4	20.1		1.0	18.7			1.2			12.3	18.7	
Actuated g/C Ratio	0.05	0.38		0.02	0.36			0.02			0.23	0.36	
Clearance Time (s)	4.5	4.5		4.5	4.5			4.5			4.5	4.5	
Vehicle Extension (s)	3.0	3.0		3.0	3.0			3.0			3.0	3.0	
Lane Grp Cap (vph)	80	1351		33	1188			37			413	562	
v/s Ratio Prot	c0.02	0.13		0.01	c0.22			c0.00			c0.16		
v/s Ratio Perm												0.03	
v/c Ratio	0.42	0.34		0.33	0.62			0.01			0.69	0.07	
Uniform Delay, d1	24.4	11.5		25.5	14.0			25.1			18.4	11.2	
Progression Factor	1.00	1.00		1.00	1.00			1.00			1.00	1.00	
Incremental Delay, d2	3.6	0.1		5.9	1.0			0.1			5.0	0.1	
Delay (s)	28.0	11.7		31.4	14.9			25.2			23.5	11.3	
Level of Service	C	B		C	B			C			C	B	
Approach Delay (s)		12.8			15.2			25.2			21.9		
Approach LOS		B			B			C			C		
<b>Intersection Summary</b>													
HCM 2000 Control Delay			15.9									HCM 2000 Level of Service	B
HCM 2000 Volume to Capacity ratio			0.61										
Actuated Cycle Length (s)			52.6									Sum of lost time (s)	18.0
Intersection Capacity Utilization			54.0%									ICU Level of Service	A
Analysis Period (min)			15										
c	Critical Lane Group												

HCM 6th TWSC  
7: Driveway 1/Gridley Drive & Shiloh Road

2028 Opening Year Alter. A Conditions  
Timing Plan: Saturday Midday Peak

Intersection												
Int Delay, s/veh	5.6											
Movement	EBL	EBT	EBR	WBL	WBT	WBR	NBL	NBT	NBR	SBL	SBT	SBR
Lane Configurations		↕	↗		↕		↕	↗			↕	
Traffic Vol, veh/h	23	463	112	0	460	0	116	0	0	0	0	20
Future Vol, veh/h	23	463	112	0	460	0	116	0	0	0	0	20
Conflicting Peds, #/hr	1	0	0	0	0	0	0	0	0	0	0	0
Sign Control	Free	Free	Free	Free	Free	Free	Stop	Stop	Stop	Stop	Stop	Stop
RT Channelized	-	-	None	-	-	None	-	-	None	-	-	None
Storage Length	-	-	150	-	-	-	0	-	-	-	-	-
Veh in Median Storage, #	-	0	-	-	0	-	-	0	-	-	0	-
Grade, %	-	0	-	-	0	-	-	0	-	-	0	-
Peak Hour Factor	93	93	93	88	88	88	100	100	100	56	56	56
Heavy Vehicles, %	2	2	2	2	2	2	2	2	2	2	2	2
Mvmt Flow	25	498	120	0	523	0	116	0	0	0	0	36

Major/Minor	Major1			Major2			Minor1			Minor2		
Conflicting Flow All	524	0	0	618	0	0	1089	1072	498	1132	1192	524
Stage 1	-	-	-	-	-	-	548	548	-	524	524	-
Stage 2	-	-	-	-	-	-	541	524	-	608	668	-
Critical Hdwy	4.12	-	-	4.12	-	-	7.12	6.52	6.22	7.12	6.52	6.22
Critical Hdwy Stg 1	-	-	-	-	-	-	6.12	5.52	-	6.12	5.52	-
Critical Hdwy Stg 2	-	-	-	-	-	-	6.12	5.52	-	6.12	5.52	-
Follow-up Hdwy	2.218	-	-	2.218	-	-	3.518	4.018	3.318	3.518	4.018	3.318
Pot Cap-1 Maneuver	1043	-	-	962	-	-	193	220	572	180	187	553
Stage 1	-	-	-	-	-	-	521	517	-	537	530	-
Stage 2	-	-	-	-	-	-	525	530	-	483	456	-
Platoon blocked, %	-	-	-	-	-	-	-	-	-	-	-	-
Mov Cap-1 Maneuver	1042	-	-	962	-	-	175	212	572	175	180	552
Mov Cap-2 Maneuver	-	-	-	-	-	-	175	212	-	175	180	-
Stage 1	-	-	-	-	-	-	502	498	-	517	529	-
Stage 2	-	-	-	-	-	-	491	529	-	465	439	-

Approach	EB	WB	NB	SB
HCM Control Delay, s	0.3	0	58.8	12
HCM LOS			F	B

Minor Lane/Major Mvmt	NBLn1	NBLn2	EBL	EBT	EBR	WBL	WBT	WBR	SBLn1
Capacity (veh/h)	175	-	1042	-	-	962	-	-	552
HCM Lane V/C Ratio	0.663	-	0.024	-	-	-	-	-	0.065
HCM Control Delay (s)	58.8	0	8.5	0	-	0	-	-	12
HCM Lane LOS	F	A	A	A	-	A	-	-	B
HCM 95th %tile Q(veh)	3.9	-	0.1	-	-	0	-	-	0.2

HCM 6th TWSC  
8: Old Redwood Hwy & Driveway 2

2028 Opening Year Alter. A Conditions  
Timing Plan: Saturday Midday Peak

Intersection												
Int Delay, s/veh	4.3											
Movement	EBL	EBT	EBR	WBL	WBT	WBR	NBL	NBT	NBR	SBL	SBT	SBR
Lane Configurations		↕		↕	↕			↕	↕	↕	↕	
Traffic Vol, veh/h	1	0	2	68	0	109	1	459	66	105	389	5
Future Vol, veh/h	1	0	2	68	0	109	1	459	66	105	389	5
Conflicting Peds, #/hr	0	0	0	0	0	0	1	0	4	4	0	1
Sign Control	Stop	Stop	Stop	Stop	Stop	Stop	Free	Free	Free	Free	Free	Free
RT Channelized	-	-	None	-	-	None	-	-	None	-	-	None
Storage Length	-	-	-	0	-	-	-	-	100	50	-	-
Veh in Median Storage, #	-	0	-	-	0	-	-	0	-	-	0	-
Grade, %	-	0	-	-	0	-	-	0	-	-	0	-
Peak Hour Factor	38	38	38	100	100	100	94	94	94	93	93	93
Heavy Vehicles, %	2	2	2	2	2	2	2	2	2	2	2	2
Mvmt Flow	3	0	5	68	0	109	1	488	70	113	418	5

Major/Minor	Minor2		Minor1		Major1		Major2					
Conflicting Flow All	1228	1212	422	1143	1144	492	424	0	0	562	0	0
Stage 1	648	648	-	494	494	-	-	-	-	-	-	-
Stage 2	580	564	-	649	650	-	-	-	-	-	-	-
Critical Hdwy	7.12	6.52	6.22	7.12	6.52	6.22	4.12	-	-	4.12	-	-
Critical Hdwy Stg 1	6.12	5.52	-	6.12	5.52	-	-	-	-	-	-	-
Critical Hdwy Stg 2	6.12	5.52	-	6.12	5.52	-	-	-	-	-	-	-
Follow-up Hdwy	3.518	4.018	3.318	3.518	4.018	3.318	2.218	-	-	2.218	-	-
Pot Cap-1 Maneuver	155	182	632	177	200	577	1135	-	-	1009	-	-
Stage 1	459	466	-	557	546	-	-	-	-	-	-	-
Stage 2	500	508	-	458	465	-	-	-	-	-	-	-
Platoon blocked, %								-	-	-	-	-
Mov Cap-1 Maneuver	115	161	631	160	177	575	1134	-	-	1005	-	-
Mov Cap-2 Maneuver	115	161	-	160	177	-	-	-	-	-	-	-
Stage 1	458	413	-	554	543	-	-	-	-	-	-	-
Stage 2	405	505	-	403	412	-	-	-	-	-	-	-

Approach	EB		WB		NB		SB	
HCM Control Delay, s	19.7		24.4		0		1.9	
HCM LOS	C		C					

Minor Lane/Major Mvmt	NBL	NBT	NBR	EBLn1	WBLn1	WBLn2	SBL	SBT	SBR
Capacity (veh/h)	1134	-	-	253	160	575	1005	-	-
HCM Lane V/C Ratio	0.001	-	-	0.031	0.425	0.19	0.112	-	-
HCM Control Delay (s)	8.2	0	-	19.7	43.2	12.7	9	-	-
HCM Lane LOS	A	A	-	C	E	B	A	-	-
HCM 95th %tile Q(veh)	0	-	-	0.1	1.9	0.7	0.4	-	-

HCM 6th TWSC  
9: Driveway 2 & Shiloh Road

2028 Opening Year Alter. A Conditions  
Timing Plan: Saturday Midday Peak

Intersection						
Int Delay, s/veh	6.4					
Movement	EBT	EBR	WBL	WBT	NBL	NBR
Lane Configurations	↑	↗		↖	↖	↗
Traffic Vol, veh/h	105	342	32	98	355	34
Future Vol, veh/h	105	342	32	98	355	34
Conflicting Peds, #/hr	0	1	0	0	0	0
Sign Control	Free	Free	Free	Free	Stop	Stop
RT Channelized	-	None	-	None	-	None
Storage Length	-	200	-	-	0	0
Veh in Median Storage, #	0	-	-	0	0	-
Grade, %	0	-	-	0	0	-
Peak Hour Factor	88	88	80	80	100	100
Heavy Vehicles, %	2	2	2	2	2	2
Mvmt Flow	119	389	40	123	355	34

Major/Minor	Major1	Major2	Minor1		
Conflicting Flow All	0	0	509	0	323
Stage 1	-	-	-	-	120
Stage 2	-	-	-	-	203
Critical Hdwy	-	-	4.12	-	6.42
Critical Hdwy Stg 1	-	-	-	-	5.42
Critical Hdwy Stg 2	-	-	-	-	5.42
Follow-up Hdwy	-	-	2.218	-	3.518
Pot Cap-1 Maneuver	-	-	1056	-	671
Stage 1	-	-	-	-	905
Stage 2	-	-	-	-	831
Platoon blocked, %	-	-	-	-	-
Mov Cap-1 Maneuver	-	-	1055	-	643
Mov Cap-2 Maneuver	-	-	-	-	643
Stage 1	-	-	-	-	904
Stage 2	-	-	-	-	797

Approach	EB	WB	NB
HCM Control Delay, s	0	2.1	16.6
HCM LOS			C

Minor Lane/Major Mvmt	NBLn1	NBLn2	EBT	EBR	WBL	WBT
Capacity (veh/h)	643	930	-	-	1055	-
HCM Lane V/C Ratio	0.552	0.037	-	-	0.038	-
HCM Control Delay (s)	17.3	9	-	-	8.5	0
HCM Lane LOS	C	A	-	-	A	A
HCM 95th %tile Q(veh)	3.4	0.1	-	-	0.1	-

HCM 6th Signalized Intersection Summary

2028 Opening Year Alter. A Conditions

10: US 101 NB Off Ramp/Lakewood Drive & Old Redwood Highway Timing Plan: Saturday Midday Peak



Movement	EBL	EBT	EBR	WBL	WBT	WBR	NBL	NBT	NBR	SBL	SBT	SBR
Lane Configurations	↔↔	↑			↔↔		↔	↔↔		↔↔		↔
Traffic Volume (veh/h)	287	379	0	0	570	276	320	303	142	244	0	700
Future Volume (veh/h)	287	379	0	0	570	276	320	303	142	244	0	700
Initial Q (Qb), veh	0	0	0	0	0	0	0	0	0	0	0	0
Ped-Bike Adj(A_pbT)	1.00		1.00	1.00		0.99	1.00		1.00	1.00		1.00
Parking Bus, Adj	1.00	1.00	1.00	1.00	1.00	1.00	1.00	1.00	1.00	1.00	1.00	1.00
Work Zone On Approach		No			No			No			No	
Adj Sat Flow, veh/h/ln	1870	1870	0	0	1870	1870	1870	1870	1870	1870	0	1870
Adj Flow Rate, veh/h	302	399	0	0	640	310	260	402	145	277	0	0
Peak Hour Factor	0.95	0.95	0.95	0.89	0.89	0.89	0.98	0.98	0.98	0.88	0.88	0.88
Percent Heavy Veh, %	2	2	0	0	2	2	2	2	2	2	0	2
Cap, veh/h	397	1173	0	0	1022	495	418	618	220	0	0	0
Arrive On Green	0.11	0.63	0.00	0.00	0.44	0.44	0.23	0.23	0.23	0.00	0.00	0.00
Sat Flow, veh/h	3456	1870	0	0	2402	1118	1781	2633	938		0	
Grp Volume(v), veh/h	302	399	0	0	493	457	260	284	263		0.0	
Grp Sat Flow(s),veh/h/ln	1728	1870	0	0	1777	1649	1781	1870	1700			
Q Serve(g_s), s	5.5	6.6	0.0	0.0	13.9	13.9	8.5	8.9	9.1			
Cycle Q Clear(g_c), s	5.5	6.6	0.0	0.0	13.9	13.9	8.5	8.9	9.1			
Prop In Lane	1.00		0.00	0.00		0.68	1.00		0.55			
Lane Grp Cap(c), veh/h	397	1173	0	0	787	731	418	439	399			
V/C Ratio(X)	0.76	0.34	0.00	0.00	0.63	0.63	0.62	0.65	0.66			
Avail Cap(c_a), veh/h	398	1173	0	0	787	731	799	839	763			
HCM Platoon Ratio	1.00	1.00	1.00	1.00	1.00	1.00	1.00	1.00	1.00			
Upstream Filter(I)	1.00	1.00	0.00	0.00	1.00	1.00	1.00	1.00	1.00			
Uniform Delay (d), s/veh	27.9	5.7	0.0	0.0	14.0	14.0	22.3	22.5	22.5			
Incr Delay (d2), s/veh	8.3	0.8	0.0	0.0	3.7	4.0	1.5	1.6	1.9			
Initial Q Delay(d3),s/veh	0.0	0.0	0.0	0.0	0.0	0.0	0.0	0.0	0.0			
%ile BackOfQ(50%),veh/ln	2.6	2.1	0.0	0.0	5.6	5.2	3.5	3.9	3.6			
Unsig. Movement Delay, s/veh												
LnGrp Delay(d),s/veh	36.2	6.5	0.0	0.0	17.7	18.0	23.8	24.1	24.4			
LnGrp LOS	D	A	A	A	B	B	C	C	C			
Approach Vol, veh/h		701			950			807				
Approach Delay, s/veh		19.3			17.8			24.1				
Approach LOS		B			B			C				
Timer - Assigned Phs		2			5	6		8				
Phs Duration (G+Y+Rc), s		45.3			12.0	33.3		19.8				
Change Period (Y+Rc), s		4.5			4.5	4.5		4.5				
Max Green Setting (Gmax), s		40.8			7.5	28.8		29.2				
Max Q Clear Time (g_c+I1), s		8.6			7.5	15.9		11.1				
Green Ext Time (p_c), s		2.5			0.0	5.0		4.0				

Intersection Summary

HCM 6th Ctrl Delay	20.3
HCM 6th LOS	C

Notes

User approved volume balancing among the lanes for turning movement.  
 Unsignalized Delay for [SBR] is excluded from calculations of the approach delay and intersection delay.

HCM 6th Signalized Intersection Summary

2028 Opening Year Alter. A Conditions

12: US 101 SB On Ramp/US 101 SB Off Ramp & Old Redwood Highway Timing Plan: Saturday Midday Peak



Movement	EBL	EBT	EBR	WBL	WBT	WBR	NBL	NBT	NBR	SBL	SBT	SBR
Lane Configurations		↑↑	↗	↘	↑↑					↘	↕	
Traffic Volume (veh/h)	0	550	419	487	818	0	0	0	0	217	1	87
Future Volume (veh/h)	0	550	419	487	818	0	0	0	0	217	1	87
Initial Q (Qb), veh	0	0	0	0	0	0				0	0	0
Ped-Bike Adj(A_pbT)	1.00		0.98	1.00		1.00				1.00		1.00
Parking Bus, Adj	1.00	1.00	1.00	1.00	1.00	1.00				1.00	1.00	1.00
Work Zone On Approach		No			No						No	
Adj Sat Flow, veh/h/ln	0	1870	1870	1870	1870	0				1870	1870	1870
Adj Flow Rate, veh/h	0	567	432	507	852	0				212	126	0
Peak Hour Factor	0.97	0.97	0.97	0.96	0.96	0.96				0.72	0.72	0.72
Percent Heavy Veh, %	0	2	2	2	2	0				2	2	2
Cap, veh/h	0	1414	619	472	2583	0				257	270	
Arrive On Green	0.00	0.40	0.40	0.26	0.73	0.00				0.14	0.14	0.00
Sat Flow, veh/h	0	3647	1555	1781	3647	0				1781	1870	0
Grp Volume(v), veh/h	0	567	432	507	852	0				212	126	0
Grp Sat Flow(s),veh/h/ln	0	1777	1555	1781	1777	0				1781	1870	0
Q Serve(g_s), s	0.0	8.0	16.2	18.5	6.0	0.0				8.1	4.3	0.0
Cycle Q Clear(g_c), s	0.0	8.0	16.2	18.5	6.0	0.0				8.1	4.3	0.0
Prop In Lane	0.00		1.00	1.00		0.00				1.00		0.00
Lane Grp Cap(c), veh/h	0	1414	619	472	2583	0				257	270	
V/C Ratio(X)	0.00	0.40	0.70	1.08	0.33	0.00				0.82	0.47	
Avail Cap(c_a), veh/h	0	1414	619	472	2583	0				260	273	
HCM Platoon Ratio	1.00	1.00	1.00	1.00	1.00	1.00				1.00	1.00	1.00
Upstream Filter(I)	0.00	1.00	1.00	1.00	1.00	0.00				1.00	1.00	0.00
Uniform Delay (d), s/veh	0.0	15.1	17.5	25.7	3.4	0.0				29.0	27.4	0.0
Incr Delay (d2), s/veh	0.0	0.8	6.4	63.1	0.3	0.0				18.9	1.3	0.0
Initial Q Delay(d3),s/veh	0.0	0.0	0.0	0.0	0.0	0.0				0.0	0.0	0.0
%ile BackOfQ(50%),veh/ln	0.0	3.1	6.2	15.4	1.3	0.0				4.7	1.9	0.0
Unsig. Movement Delay, s/veh												
LnGrp Delay(d),s/veh	0.0	15.9	24.0	88.8	3.8	0.0				47.9	28.7	0.0
LnGrp LOS	A	B	C	F	A	A				D	C	
Approach Vol, veh/h		999			1359						338	
Approach Delay, s/veh		19.4			35.5						40.8	
Approach LOS		B			D						D	
Timer - Assigned Phs		2			5	6		8				
Phs Duration (G+Y+Rc), s		55.3			23.0	32.3		14.6				
Change Period (Y+Rc), s		4.5			4.5	4.5		4.5				
Max Green Setting (Gmax), s		50.8			18.5	27.8		10.2				
Max Q Clear Time (g_c+I1), s		8.0			20.5	18.2		10.1				
Green Ext Time (p_c), s		7.0			0.0	3.8		0.0				

Intersection Summary

HCM 6th Ctrl Delay	30.2
HCM 6th LOS	C

Notes

- User approved volume balancing among the lanes for turning movement.
- User approved ignoring U-Turning movement.
- Unsignalized Delay for [SBR] is excluded from calculations of the approach delay and intersection delay.

Queues  
1: Old Redwood Hwy & Shiloh Road

2028 Opening Year Alter. A Conditions  
Timing Plan: A.M. PEAK



Lane Group	EBL	EBT	EBR	WBT	WBR	NBL	NBT	NBR	SBL	SBT	SBR
Lane Group Flow (vph)	169	358	167	230	31	129	157	42	44	316	245
v/c Ratio	0.37	0.74	0.34	0.66	0.08	0.57	0.26	0.07	0.39	0.71	0.52
Control Delay	35.1	45.7	15.8	48.6	0.4	55.6	27.8	1.5	61.6	45.2	20.4
Queue Delay	0.0	0.0	0.0	0.0	0.0	0.0	0.0	0.0	0.0	0.0	0.0
Total Delay	35.1	45.7	15.8	48.6	0.4	55.6	27.8	1.5	61.6	45.2	20.4
Queue Length 50th (ft)	86	205	29	137	0	78	75	0	28	186	59
Queue Length 95th (ft)	161	336	82	248	0	#169	143	6	#75	297	135
Internal Link Dist (ft)		1709		528			668			695	
Turn Bay Length (ft)	375		140		50	200		98	130		93
Base Capacity (vph)	589	620	597	768	717	280	884	792	116	711	673
Starvation Cap Reductn	0	0	0	0	0	0	0	0	0	0	0
Spillback Cap Reductn	0	0	0	0	0	0	0	0	0	0	0
Storage Cap Reductn	0	0	0	0	0	0	0	0	0	0	0
Reduced v/c Ratio	0.29	0.58	0.28	0.30	0.04	0.46	0.18	0.05	0.38	0.44	0.36

Intersection Summary

# 95th percentile volume exceeds capacity, queue may be longer.  
Queue shown is maximum after two cycles.

Queues

2028 Opening Year Alter. A Conditions

2: Shiloh Road & Hembree Ln

Timing Plan: A.M. PEAK

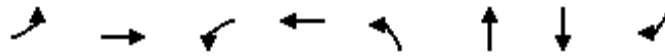

Lane Group	EBL	EBT	WBL	WBT	NBL	NBT	SBT	SBR
Lane Group Flow (vph)	394	619	19	565	39	18	95	439
v/c Ratio	0.52	0.57	0.10	0.53	0.20	0.09	0.34	0.52
Control Delay	25.4	11.3	34.1	17.7	34.8	24.3	31.5	6.7
Queue Delay	0.0	0.0	0.0	0.0	0.0	0.0	0.0	0.0
Total Delay	25.4	11.3	34.1	17.7	34.8	24.3	31.5	6.7
Queue Length 50th (ft)	64	135	6	87	13	2	31	18
Queue Length 95th (ft)	144	286	32	137	53	25	98	112
Internal Link Dist (ft)		222		1709		136	301	
Turn Bay Length (ft)			100					
Base Capacity (vph)	1146	1597	191	2648	191	192	350	981
Starvation Cap Reductn	0	0	0	0	0	0	0	0
Spillback Cap Reductn	0	0	0	0	0	0	0	0
Storage Cap Reductn	0	0	0	0	0	0	0	0
Reduced v/c Ratio	0.34	0.39	0.10	0.21	0.20	0.09	0.27	0.45

Intersection Summary



Queues  
3: US 101 NB Off-Ramp & Shiloh Road

2028 Opening Year Alter. A Conditions  
Timing Plan: A.M. PEAK



Lane Group	EBT	WBT	NBL	NBR
Lane Group Flow (vph)	396	790	647	726
v/c Ratio	0.24	0.92	0.87	0.47
Control Delay	12.0	36.2	33.6	3.4
Queue Delay	0.0	0.0	0.0	0.0
Total Delay	12.0	36.2	33.6	3.4
Queue Length 50th (ft)	53	315	248	14
Queue Length 95th (ft)	81	#546	293	23
Internal Link Dist (ft)	106	291	689	
Turn Bay Length (ft)				265
Base Capacity (vph)	1756	924	825	1634
Starvation Cap Reductn	0	0	0	0
Spillback Cap Reductn	0	0	0	0
Storage Cap Reductn	0	0	0	0
Reduced v/c Ratio	0.23	0.85	0.78	0.44

Intersection Summary

# 95th percentile volume exceeds capacity, queue may be longer.  
Queue shown is maximum after two cycles.

Queues  
4: Shiloh Road & US 101 SB Off-Ramp

2028 Opening Year Alter. A Conditions  
Timing Plan: A.M. PEAK

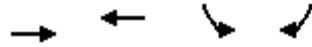

Lane Group	EBT	WBT	SBL	SBR
Lane Group Flow (vph)	302	754	176	189
v/c Ratio	0.29	0.71	0.43	0.37
Control Delay	5.5	11.1	20.1	6.0
Queue Delay	0.0	0.0	0.0	0.0
Total Delay	5.5	11.1	20.1	6.0
Queue Length 50th (ft)	29	101	35	0
Queue Length 95th (ft)	73	248	106	43
Internal Link Dist (ft)	145	226	406	
Turn Bay Length (ft)				275
Base Capacity (vph)	1863	1863	750	779
Starvation Cap Reductn	0	0	0	0
Spillback Cap Reductn	0	0	0	0
Storage Cap Reductn	0	0	0	0
Reduced v/c Ratio	0.16	0.40	0.23	0.24
<b>Intersection Summary</b>				

Queues  
6: Conde Lane & Shiloh Road

2028 Opening Year Alter. A Conditions  
Timing Plan: A.M. PEAK

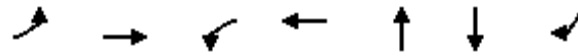

Lane Group	EBL	EBT	WBL	WBT	NBT	SBT	SBR
Lane Group Flow (vph)	29	408	12	755	34	272	47
v/c Ratio	0.08	0.28	0.03	0.56	0.07	0.57	0.08
Control Delay	25.6	10.6	25.9	13.1	0.3	30.3	13.2
Queue Delay	0.0	0.0	0.0	0.0	0.0	0.0	0.0
Total Delay	25.6	10.6	25.9	13.1	0.3	30.3	13.2
Queue Length 50th (ft)	5	22	2	37	0	47	4
Queue Length 95th (ft)	35	98	18	155	0	#248	32
Internal Link Dist (ft)		735		1001	338	442	
Turn Bay Length (ft)	90		127				40
Base Capacity (vph)	392	2974	348	2818	1285	480	1323
Starvation Cap Reductn	0	0	0	0	0	0	0
Spillback Cap Reductn	0	0	0	0	0	0	0
Storage Cap Reductn	0	0	0	0	0	0	0
Reduced v/c Ratio	0.07	0.14	0.03	0.27	0.03	0.57	0.04

Intersection Summary

# 95th percentile volume exceeds capacity, queue may be longer.  
Queue shown is maximum after two cycles.

Queues

2028 Opening Year Alter. A Conditions

10: US 101 NB Off Ramp/Lakewood Drive & Old Redwood Highway

Timing Plan: A.M. PEAK



Lane Group	EBL	EBT	WBT	NBL	NBT	SBL	SBR
Lane Group Flow (vph)	204	233	832	221	446	151	683
v/c Ratio	0.54	0.24	0.68	0.61	0.59	0.50	0.86
Control Delay	40.3	12.8	24.9	34.9	27.7	41.8	25.1
Queue Delay	0.0	0.0	0.0	0.0	0.0	0.0	0.0
Total Delay	40.3	12.8	24.9	34.9	27.7	41.8	25.1
Queue Length 50th (ft)	49	60	170	107	97	37	185
Queue Length 95th (ft)	86	117	244	181	143	72	335
Internal Link Dist (ft)		146	537		636		
Turn Bay Length (ft)	155			270		120	
Base Capacity (vph)	393	952	1225	594	1222	305	797
Starvation Cap Reductn	0	0	0	0	0	0	0
Spillback Cap Reductn	0	0	0	0	0	0	0
Storage Cap Reductn	0	0	0	0	0	0	0
Reduced v/c Ratio	0.52	0.24	0.68	0.37	0.36	0.50	0.86

Intersection Summary

Queues

12: US 101 SB On Ramp/US 101 SB Off Ramp & Old Redwood Highway



Lane Group	EBT	EBR	WBL	WBT	SBL	SBT
Lane Group Flow (vph)	368	366	656	645	133	123
v/c Ratio	0.31	0.48	1.02	0.24	0.63	0.45
Control Delay	20.3	5.2	69.4	3.2	48.4	17.6
Queue Delay	0.0	0.0	0.0	0.0	0.0	0.0
Total Delay	20.3	5.2	69.4	3.2	48.4	17.6
Queue Length 50th (ft)	70	5	~338	40	67	15
Queue Length 95th (ft)	104	62	#544	54	#113	53
Internal Link Dist (ft)	343			451		751
Turn Bay Length (ft)			250		420	
Base Capacity (vph)	1203	760	641	2663	210	273
Starvation Cap Reductn	0	0	0	0	0	0
Spillback Cap Reductn	0	0	0	0	0	0
Storage Cap Reductn	0	0	0	0	0	0
Reduced v/c Ratio	0.31	0.48	1.02	0.24	0.63	0.45

Intersection Summary

~ Volume exceeds capacity, queue is theoretically infinite.

Queue shown is maximum after two cycles.

# 95th percentile volume exceeds capacity, queue may be longer.

Queue shown is maximum after two cycles.

Queues  
1: Old Redwood Hwy & Shiloh Road

2028 Opening Year Alter. A Conditions

Timing Plan: P.M. Peak



Lane Group	EBL	EBT	EBR	WBT	WBR	NBL	NBT	NBR	SBL	SBT	SBR
Lane Group Flow (vph)	299	547	318	479	63	274	426	26	89	304	197
v/c Ratio	0.68	1.17	0.64	0.91	0.12	1.30	0.83	0.05	1.02	0.79	0.49
Control Delay	52.4	140.6	31.9	65.5	1.7	209.5	56.5	0.2	162.8	61.7	23.2
Queue Delay	0.0	0.0	0.0	0.0	0.0	0.0	0.0	0.0	0.0	0.0	0.0
Total Delay	52.4	140.6	31.9	65.5	1.7	209.5	56.5	0.2	162.8	61.7	23.2
Queue Length 50th (ft)	222	~541	137	365	0	~290	328	0	~79	237	60
Queue Length 95th (ft)	#356	#838	263	#616	8	#508	453	0	#205	340	134
Internal Link Dist (ft)		1709		528			668			695	
Turn Bay Length (ft)	375		140		50	200		98	130		93
Base Capacity (vph)	442	466	494	577	555	210	665	601	87	534	521
Starvation Cap Reductn	0	0	0	0	0	0	0	0	0	0	0
Spillback Cap Reductn	0	0	0	0	0	0	0	0	0	0	0
Storage Cap Reductn	0	0	0	0	0	0	0	0	0	0	0
Reduced v/c Ratio	0.68	1.17	0.64	0.83	0.11	1.30	0.64	0.04	1.02	0.57	0.38

Intersection Summary

~ Volume exceeds capacity, queue is theoretically infinite.

Queue shown is maximum after two cycles.

# 95th percentile volume exceeds capacity, queue may be longer.

Queue shown is maximum after two cycles.

Queues  
2: Shiloh Road & Hembree Ln

2028 Opening Year Alter. A Conditions  
Timing Plan: P.M. Peak

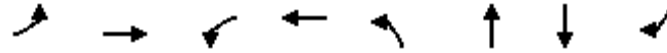

Lane Group	EBL	EBT	WBL	WBT	NBL	NBT	SBT	SBR
Lane Group Flow (vph)	745	1074	24	989	65	26	215	595
v/c Ratio	0.99	0.91	0.19	0.69	0.52	0.19	0.94	0.91
Control Delay	66.7	28.0	43.0	21.2	56.1	28.5	87.1	40.2
Queue Delay	0.0	1.4	0.0	0.0	0.0	0.0	0.0	0.0
Total Delay	66.7	29.4	43.0	21.2	56.1	28.5	87.1	40.2
Queue Length 50th (ft)	~209	381	12	205	32	5	110	168
Queue Length 95th (ft)	#370	#874	39	255	#96	32	#278	#537
Internal Link Dist (ft)		222		1709		136	301	
Turn Bay Length (ft)			100					
Base Capacity (vph)	750	1263	125	1849	125	134	228	653
Starvation Cap Reductn	0	69	0	0	0	0	0	0
Spillback Cap Reductn	0	0	0	0	0	0	0	0
Storage Cap Reductn	0	0	0	0	0	0	0	0
Reduced v/c Ratio	0.99	0.90	0.19	0.53	0.52	0.19	0.94	0.91

Intersection Summary

- ~ Volume exceeds capacity, queue is theoretically infinite.  
Queue shown is maximum after two cycles.
- # 95th percentile volume exceeds capacity, queue may be longer.  
Queue shown is maximum after two cycles.

Queues  
3: US 101 NB Off-Ramp & Shiloh Road

2028 Opening Year Alter. A Conditions  
Timing Plan: P.M. Peak



Lane Group	EBT	WBT	NBL	NBR
Lane Group Flow (vph)	689	944	666	1188
v/c Ratio	0.42	1.09	0.90	0.90
Control Delay	13.8	79.1	36.3	25.4
Queue Delay	0.0	0.0	0.0	0.0
Total Delay	13.8	79.1	36.3	25.4
Queue Length 50th (ft)	103	~489	260	211
Queue Length 95th (ft)	144	#703	#461	#363
Internal Link Dist (ft)	106	291	689	
Turn Bay Length (ft)				265
Base Capacity (vph)	1651	869	776	1371
Starvation Cap Reductn	0	0	0	0
Spillback Cap Reductn	0	0	0	0
Storage Cap Reductn	0	0	0	0
Reduced v/c Ratio	0.42	1.09	0.86	0.87

Intersection Summary

- ~ Volume exceeds capacity, queue is theoretically infinite.  
Queue shown is maximum after two cycles.
- # 95th percentile volume exceeds capacity, queue may be longer.  
Queue shown is maximum after two cycles.



Queues  
4: Shiloh Road & US 101 SB Off-Ramp

2028 Opening Year Alter. A Conditions  
Timing Plan: P.M. Peak

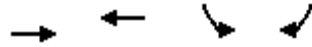

Lane Group	EBT	WBT	SBL	SBR
Lane Group Flow (vph)	599	770	342	157
v/c Ratio	0.63	0.80	0.59	0.26
Control Delay	11.9	17.5	22.8	5.1
Queue Delay	0.0	0.0	0.0	0.0
Total Delay	11.9	17.5	22.8	5.1
Queue Length 50th (ft)	117	174	85	0
Queue Length 95th (ft)	185	285	#237	39
Internal Link Dist (ft)	145	226	406	
Turn Bay Length (ft)				275
Base Capacity (vph)	1863	1863	584	615
Starvation Cap Reductn	0	0	0	0
Spillback Cap Reductn	0	0	0	0
Storage Cap Reductn	0	0	0	0
Reduced v/c Ratio	0.32	0.41	0.59	0.26

Intersection Summary

# 95th percentile volume exceeds capacity, queue may be longer.  
Queue shown is maximum after two cycles.

Queues  
6: Conde Lane & Shiloh Road

2028 Opening Year Alter. A Conditions  
Timing Plan: P.M. Peak

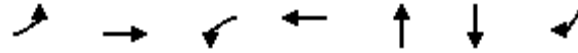

Lane Group	EBL	EBT	WBL	WBT	NBT	SBT	SBR
Lane Group Flow (vph)	90	650	10	1091	45	384	50
v/c Ratio	0.35	0.34	0.04	0.73	0.14	1.15	0.07
Control Delay	37.8	9.8	35.2	17.7	19.1	132.1	13.3
Queue Delay	0.0	0.0	0.0	0.0	0.0	0.0	0.0
Total Delay	37.8	9.8	35.2	17.7	19.1	132.1	13.3
Queue Length 50th (ft)	41	78	5	204	7	~264	14
Queue Length 95th (ft)	92	150	18	224	22	#471	33
Internal Link Dist (ft)		735		1001	338	442	
Turn Bay Length (ft)	90		127				40
Base Capacity (vph)	273	2435	242	2209	960	333	1034
Starvation Cap Reductn	0	0	0	0	0	0	0
Spillback Cap Reductn	0	0	0	0	0	0	0
Storage Cap Reductn	0	0	0	0	0	0	0
Reduced v/c Ratio	0.33	0.27	0.04	0.49	0.05	1.15	0.05

**Intersection Summary**

~ Volume exceeds capacity, queue is theoretically infinite.  
Queue shown is maximum after two cycles.

# 95th percentile volume exceeds capacity, queue may be longer.  
Queue shown is maximum after two cycles.

Queues

2028 Opening Year Alter. A Conditions

10: US 101 NB Off Ramp/Lakewood Drive & Old Redwood Highway

Timing Plan: P.M. Peak



Lane Group	EBL	EBT	WBT	NBL	NBT	SBL	SBR
Lane Group Flow (vph)	341	540	917	482	957	296	684
v/c Ratio	0.99	0.65	0.86	0.93	0.88	1.11	0.77
Control Delay	89.6	23.9	37.9	56.9	37.7	127.8	18.5
Queue Delay	0.0	0.0	0.0	0.0	0.0	0.0	0.0
Total Delay	89.6	23.9	37.9	56.9	37.7	127.8	18.5
Queue Length 50th (ft)	101	232	243	289	259	~100	193
Queue Length 95th (ft)	#179	326	#351	#498	#381	#181	350
Internal Link Dist (ft)		146	537		636		
Turn Bay Length (ft)	155			270		120	
Base Capacity (vph)	343	832	1061	518	1082	267	890
Starvation Cap Reductn	0	0	0	0	0	0	0
Spillback Cap Reductn	0	0	0	0	0	0	0
Storage Cap Reductn	0	0	0	0	0	0	0
Reduced v/c Ratio	0.99	0.65	0.86	0.93	0.88	1.11	0.77

Intersection Summary

~ Volume exceeds capacity, queue is theoretically infinite.

Queue shown is maximum after two cycles.

# 95th percentile volume exceeds capacity, queue may be longer.

Queue shown is maximum after two cycles.

Queues

2028 Opening Year Alter. A Conditions

12: US 101 SB On Ramp/US 101 SB Off Ramp & Old Redwood Highway

Timing Plan: P.M. Peak



Lane Group	EBT	EBR	WBL	WBT	SBL	SBT
Lane Group Flow (vph)	648	462	488	1310	257	234
v/c Ratio	0.46	0.52	1.07	0.52	1.04	0.76
Control Delay	16.8	4.1	91.7	5.5	101.9	34.9
Queue Delay	0.0	0.0	0.0	0.0	0.0	0.0
Total Delay	16.8	4.1	91.7	5.5	101.9	34.9
Queue Length 50th (ft)	104	2	~239	107	~128	60
Queue Length 95th (ft)	148	55	#403	141	#237	#142
Internal Link Dist (ft)	343			451		751
Turn Bay Length (ft)			250		420	
Base Capacity (vph)	1410	893	455	2522	247	309
Starvation Cap Reductn	0	0	0	0	0	0
Spillback Cap Reductn	0	0	0	0	0	0
Storage Cap Reductn	0	0	0	0	0	0
Reduced v/c Ratio	0.46	0.52	1.07	0.52	1.04	0.76

Intersection Summary

~ Volume exceeds capacity, queue is theoretically infinite.

Queue shown is maximum after two cycles.

# 95th percentile volume exceeds capacity, queue may be longer.

Queue shown is maximum after two cycles.

Queues  
1: Old Redwood Hwy & Shiloh Road

2028 Opening Year Alter. A Conditions  
Timing Plan: Saturday Midday Peak



Lane Group	EBL	EBT	EBR	WBT	WBR	NBL	NBT	NBR	SBL	SBT	SBR
Lane Group Flow (vph)	175	544	325	609	83	318	301	29	84	252	263
v/c Ratio	0.40	1.17	0.66	1.05	0.15	1.57	0.65	0.06	1.06	0.75	0.62
Control Delay	42.7	138.3	31.8	93.4	3.1	314.6	47.7	0.3	173.7	61.7	22.0
Queue Delay	0.0	0.0	0.0	0.0	0.0	0.0	0.0	0.0	0.0	0.0	0.0
Total Delay	42.7	138.3	31.8	93.4	3.1	314.6	47.7	0.3	173.7	61.7	22.0
Queue Length 50th (ft)	115	~506	134	~520	0	~353	213	0	~72	190	59
Queue Length 95th (ft)	199	#794	258	#777	16	#585	308	0	#195	281	148
Internal Link Dist (ft)		1709		528			668			695	
Turn Bay Length (ft)	375		140		50	200		98	130		93
Base Capacity (vph)	442	465	489	578	570	203	664	604	79	534	567
Starvation Cap Reductn	0	0	0	0	0	0	0	0	0	0	0
Spillback Cap Reductn	0	0	0	0	0	0	0	0	0	0	0
Storage Cap Reductn	0	0	0	0	0	0	0	0	0	0	0
Reduced v/c Ratio	0.40	1.17	0.66	1.05	0.15	1.57	0.45	0.05	1.06	0.47	0.46

Intersection Summary

~ Volume exceeds capacity, queue is theoretically infinite.

Queue shown is maximum after two cycles.

# 95th percentile volume exceeds capacity, queue may be longer.

Queue shown is maximum after two cycles.

Queues

2028 Opening Year Alter. A Conditions

2: Shiloh Road & Hembree Ln

Timing Plan: Saturday Midday Peak

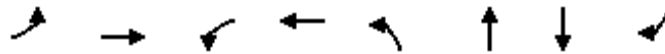

Lane Group	EBL	EBT	WBL	WBT	NBL	NBT	SBT	SBR
Lane Group Flow (vph)	753	950	24	1018	65	26	211	732
v/c Ratio	0.98	0.81	0.19	0.74	0.51	0.19	0.91	1.11
Control Delay	63.0	20.2	42.6	22.6	54.6	28.5	78.5	92.0
Queue Delay	0.0	0.4	0.0	0.0	0.0	0.0	0.0	0.0
Total Delay	63.0	20.5	42.6	22.6	54.6	28.5	78.5	92.0
Queue Length 50th (ft)	~195	290	11	214	32	5	104	~355
Queue Length 95th (ft)	#375	#715	39	280	#96	32	#272	#724
Internal Link Dist (ft)		222		1709		136	301	
Turn Bay Length (ft)			100					
Base Capacity (vph)	767	1290	128	1890	128	136	233	660
Starvation Cap Reductn	0	68	0	0	0	0	0	0
Spillback Cap Reductn	0	0	0	0	0	0	0	0
Storage Cap Reductn	0	0	0	0	0	0	0	0
Reduced v/c Ratio	0.98	0.78	0.19	0.54	0.51	0.19	0.91	1.11

Intersection Summary

~ Volume exceeds capacity, queue is theoretically infinite.

Queue shown is maximum after two cycles.

# 95th percentile volume exceeds capacity, queue may be longer.

Queue shown is maximum after two cycles.

Queues  
3: US 101 NB Off-Ramp & Shiloh Road

2028 Opening Year Alter. A Conditions  
Timing Plan: Saturday Midday Peak

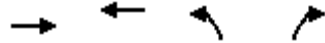

Lane Group	EBT	WBT	NBL	NBR
Lane Group Flow (vph)	639	1115	401	954
v/c Ratio	0.33	1.08	0.70	0.83
Control Delay	10.5	73.2	28.7	20.6
Queue Delay	0.0	0.0	0.0	0.0
Total Delay	10.5	73.2	28.7	20.6
Queue Length 50th (ft)	80	~598	157	139
Queue Length 95th (ft)	132	#912	248	221
Internal Link Dist (ft)	106	291	689	
Turn Bay Length (ft)				265
Base Capacity (vph)	1961	1032	738	1377
Starvation Cap Reductn	0	0	0	0
Spillback Cap Reductn	0	0	0	0
Storage Cap Reductn	0	0	0	0
Reduced v/c Ratio	0.33	1.08	0.54	0.69

Intersection Summary

- ~ Volume exceeds capacity, queue is theoretically infinite.  
Queue shown is maximum after two cycles.
- # 95th percentile volume exceeds capacity, queue may be longer.  
Queue shown is maximum after two cycles.

Queues  
4: Shiloh Road & US 101 SB Off-Ramp

2028 Opening Year Alter. A Conditions  
Timing Plan: Saturday Midday Peak

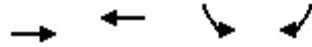

Lane Group	EBT	WBT	SBL	SBR
Lane Group Flow (vph)	366	660	553	256
v/c Ratio	0.43	0.77	0.90	0.36
Control Delay	9.9	17.2	39.9	4.3
Queue Delay	0.0	0.0	0.0	0.0
Total Delay	9.9	17.2	39.9	4.3
Queue Length 50th (ft)	62	139	138	0
Queue Length 95th (ft)	107	234	#245	15
Internal Link Dist (ft)	145	226	406	
Turn Bay Length (ft)				275
Base Capacity (vph)	1863	1863	615	717
Starvation Cap Reductn	0	0	0	0
Spillback Cap Reductn	0	0	0	0
Storage Cap Reductn	0	0	0	0
Reduced v/c Ratio	0.20	0.35	0.90	0.36

Intersection Summary

# 95th percentile volume exceeds capacity, queue may be longer.  
Queue shown is maximum after two cycles.



Queues  
6: Conde Lane & Shiloh Road

2028 Opening Year Alter. A Conditions  
Timing Plan: Saturday Midday Peak

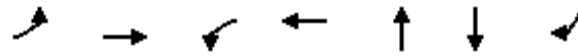

Lane Group	EBL	EBT	WBL	WBT	NBT	SBT	SBR
Lane Group Flow (vph)	34	454	11	785	14	287	41
v/c Ratio	0.10	0.29	0.03	0.58	0.03	0.60	0.07
Control Delay	23.9	9.8	24.5	13.0	0.1	28.8	12.0
Queue Delay	0.0	0.0	0.0	0.0	0.0	0.0	0.0
Total Delay	23.9	9.8	24.5	13.0	0.1	28.8	12.0
Queue Length 50th (ft)	6	26	2	45	0	48	4
Queue Length 95th (ft)	41	114	20	193	0	#247	27
Internal Link Dist (ft)		735		1001	338	442	
Turn Bay Length (ft)	90		127				40
Base Capacity (vph)	369	3083	347	2911	1314	477	1374
Starvation Cap Reductn	0	0	0	0	0	0	0
Spillback Cap Reductn	0	0	0	0	0	0	0
Storage Cap Reductn	0	0	0	0	0	0	0
Reduced v/c Ratio	0.09	0.15	0.03	0.27	0.01	0.60	0.03

Intersection Summary

# 95th percentile volume exceeds capacity, queue may be longer.  
Queue shown is maximum after two cycles.

Queues

2028 Opening Year Alter. A Conditions

10: US 101 NB Off Ramp/Lakewood Drive & Old Redwood Highway Timing Plan: Saturday Midday Peak



Lane Group	EBL	EBT	WBT	NBL	NBT	SBL	SBR
Lane Group Flow (vph)	302	399	950	262	519	277	795
v/c Ratio	0.96	0.43	0.76	0.66	0.61	0.94	1.01
Control Delay	81.7	16.1	27.1	35.6	26.8	80.3	51.1
Queue Delay	0.0	0.0	0.0	0.0	0.0	0.0	0.0
Total Delay	81.7	16.1	27.1	35.6	26.8	80.3	51.1
Queue Length 50th (ft)	81	125	204	131	113	74	294
Queue Length 95th (ft)	#180	234	314	215	163	#162	#537
Internal Link Dist (ft)		146	537		636		
Turn Bay Length (ft)	155			270		120	
Base Capacity (vph)	315	932	1244	576	1191	294	790
Starvation Cap Reductn	0	0	0	0	0	0	0
Spillback Cap Reductn	0	0	0	0	0	0	0
Storage Cap Reductn	0	0	0	0	0	0	0
Reduced v/c Ratio	0.96	0.43	0.76	0.45	0.44	0.94	1.01

Intersection Summary

# 95th percentile volume exceeds capacity, queue may be longer.  
 Queue shown is maximum after two cycles.

Queues

2028 Opening Year Alter. A Conditions

12: US 101 SB On Ramp/US 101 SB Off Ramp & Old Redwood Highway Timing Plan: Saturday Midday Peak



Lane Group	EBT	EBR	WBL	WBT	SBL	SBT
Lane Group Flow (vph)	567	432	507	852	220	203
v/c Ratio	0.40	0.49	1.09	0.33	0.90	0.66
Control Delay	16.2	3.8	95.1	3.9	70.1	28.3
Queue Delay	0.0	0.0	0.0	0.0	0.0	0.0
Total Delay	16.2	3.8	95.1	3.9	70.1	28.3
Queue Length 50th (ft)	89	0	~251	54	100	48
Queue Length 95th (ft)	128	50	#424	74	#155	80
Internal Link Dist (ft)	343			451		751
Turn Bay Length (ft)			250		420	
Base Capacity (vph)	1405	877	467	2568	244	306
Starvation Cap Reductn	0	0	0	0	0	0
Spillback Cap Reductn	0	0	0	0	0	0
Storage Cap Reductn	0	0	0	0	0	0
Reduced v/c Ratio	0.40	0.49	1.09	0.33	0.90	0.66

Intersection Summary

























~ Volume exceeds capacity, queue is theoretically infinite.

Queue shown is maximum after two cycles.

# 95th percentile volume exceeds capacity, queue may be longer.

























Queue shown is maximum after two cycles.

HCM 6th Signalized Intersection Summary 2028 Opening Year Alter. A Conditions Mitigations  
 1: Old Redwood Hwy & Shiloh Road Timing Plan: A.M. PEAK

























												
Movement	EBL	EBT	EBR	WBL	WBT	WBR	NBL	NBT	NBR	SBL	SBT	SBR
Lane Configurations												
Traffic Volume (veh/h)	137	290	135	25	180	28	120	146	39	37	269	208
Future Volume (veh/h)	137	290	135	25	180	28	120	146	39	37	269	208
Initial Q (Qb), veh	0	0	0	0	0	0	0	0	0	0	0	0
Ped-Bike Adj(A_pbT)	1.00		1.00	1.00		1.00	1.00		1.00	1.00		0.99
Parking Bus, Adj	1.00	1.00	1.00	1.00	1.00	1.00	1.00	1.00	1.00	1.00	1.00	1.00
Work Zone On Approach		No			No			No			No	
Adj Sat Flow, veh/h/ln	1870	1870	1870	1870	1870	1870	1870	1870	1870	1870	1870	1870
Adj Flow Rate, veh/h	169	358	167	28	202	31	129	157	42	44	316	245
Peak Hour Factor	0.81	0.81	0.81	0.89	0.89	0.89	0.93	0.93	0.93	0.85	0.85	0.85
Percent Heavy Veh, %	2	2	2	2	2	2	2	2	2	2	2	2
Cap, veh/h	456	478	405	274	287	244	282	432	366	146	433	362
Arrive On Green	0.26	0.26	0.26	0.15	0.15	0.15	0.08	0.23	0.23	0.08	0.23	0.23
Sat Flow, veh/h	1781	1870	1585	1781	1870	1585	3456	1870	1585	1781	1870	1565
Grp Volume(v), veh/h	169	358	167	28	202	31	129	157	42	44	316	245
Grp Sat Flow(s),veh/h/ln	1781	1870	1585	1781	1870	1585	1728	1870	1585	1781	1870	1565
Q Serve(g_s), s	4.8	10.8	5.4	0.8	6.3	1.0	2.2	4.3	1.3	1.4	9.6	8.7
Cycle Q Clear(g_c), s	4.8	10.8	5.4	0.8	6.3	1.0	2.2	4.3	1.3	1.4	9.6	8.7
Prop In Lane	1.00		1.00	1.00		1.00	1.00		1.00	1.00		1.00
Lane Grp Cap(c), veh/h	456	478	405	274	287	244	282	432	366	146	433	362
V/C Ratio(X)	0.37	0.75	0.41	0.10	0.70	0.13	0.46	0.36	0.11	0.30	0.73	0.68
Avail Cap(c_a), veh/h	888	932	790	1106	1161	984	819	1329	1126	175	1069	895
HCM Platoon Ratio	1.00	1.00	1.00	1.00	1.00	1.00	1.00	1.00	1.00	1.00	1.00	1.00
Upstream Filter(I)	1.00	1.00	1.00	1.00	1.00	1.00	1.00	1.00	1.00	1.00	1.00	1.00
Uniform Delay (d), s/veh	18.7	21.0	18.9	22.3	24.6	22.4	26.8	19.8	18.6	26.5	21.8	21.4
Incr Delay (d2), s/veh	0.5	2.4	0.7	0.2	3.1	0.2	1.2	0.5	0.1	1.2	2.4	2.2
Initial Q Delay(d3),s/veh	0.0	0.0	0.0	0.0	0.0	0.0	0.0	0.0	0.0	0.0	0.0	0.0
%ile BackOfQ(50%),veh/ln	1.8	4.4	1.8	0.3	2.8	0.4	0.9	1.7	0.4	0.6	4.0	3.0
Unsig. Movement Delay, s/veh												
LnGrp Delay(d),s/veh	19.2	23.3	19.6	22.4	27.7	22.6	28.0	20.3	18.7	27.6	24.2	23.7
LnGrp LOS	B	C	B	C	C	C	C	C	B	C	C	C
Approach Vol, veh/h		694			261			328			605	
Approach Delay, s/veh		21.4			26.5			23.1			24.2	
Approach LOS		C			C			C			C	
Timer - Assigned Phs		2	3	4		6	7	8				
Phs Duration (G+Y+Rc), s		20.2	8.5	18.7		13.9	8.5	18.6				
Change Period (Y+Rc), s		4.5	3.5	4.5		4.5	3.5	4.5				
Max Green Setting (Gmax), s		30.5	14.5	35.0		38.0	6.0	43.5				
Max Q Clear Time (g_c+I1), s		12.8	4.2	11.6		8.3	3.4	6.3				
Green Ext Time (p_c), s		2.9	0.2	2.6		1.2	0.0	0.9				
<b>Intersection Summary</b>												
HCM 6th Ctrl Delay			23.3									
HCM 6th LOS			C									

HCM 6th Signalized Intersection Summary 2028 Opening Year Alter. A Conditions Mitigations  
 1: Old Redwood Hwy & Shiloh Road

Timing Plan: P.M. Peak

												
Movement	EBL	EBT	EBR	WBL	WBT	WBR	NBL	NBT	NBR	SBL	SBT	SBR
Lane Configurations												
Traffic Volume (veh/h)	290	531	308	42	394	57	255	396	24	83	283	183
Future Volume (veh/h)	290	531	308	42	394	57	255	396	24	83	283	183
Initial Q (Qb), veh	0	0	0	0	0	0	0	0	0	0	0	0
Ped-Bike Adj(A_pbT)	1.00		1.00	1.00		1.00	1.00		0.97	1.00		0.98
Parking Bus, Adj	1.00	1.00	1.00	1.00	1.00	1.00	1.00	1.00	1.00	1.00	1.00	1.00
Work Zone On Approach		No			No			No			No	
Adj Sat Flow, veh/h/ln	1870	1870	1870	1870	1870	1870	1870	1870	1870	1870	1870	1870
Adj Flow Rate, veh/h	299	547	318	46	433	63	274	426	26	89	304	197
Peak Hour Factor	0.97	0.97	0.97	0.91	0.91	0.91	0.93	0.93	0.93	0.93	0.93	0.93
Percent Heavy Veh, %	2	2	2	2	2	2	2	2	2	2	2	2
Cap, veh/h	345	771	653	100	513	434	363	504	416	127	442	368
Arrive On Green	0.19	0.41	0.41	0.06	0.27	0.27	0.10	0.27	0.27	0.07	0.24	0.24
Sat Flow, veh/h	1781	1870	1583	1781	1870	1582	3456	1870	1544	1781	1870	1560
Grp Volume(v), veh/h	299	547	318	46	433	63	274	426	26	89	304	197
Grp Sat Flow(s),veh/h/ln	1781	1870	1583	1781	1870	1582	1728	1870	1544	1781	1870	1560
Q Serve(g_s), s	14.5	21.7	13.2	2.2	19.5	2.7	6.9	19.2	1.1	4.4	13.2	9.9
Cycle Q Clear(g_c), s	14.5	21.7	13.2	2.2	19.5	2.7	6.9	19.2	1.1	4.4	13.2	9.9
Prop In Lane	1.00		1.00	1.00		1.00	1.00		1.00	1.00		1.00
Lane Grp Cap(c), veh/h	345	771	653	100	513	434	363	504	416	127	442	368
V/C Ratio(X)	0.87	0.71	0.49	0.46	0.84	0.15	0.76	0.84	0.06	0.70	0.69	0.53
Avail Cap(c_a), veh/h	698	828	701	758	891	753	600	884	730	166	733	612
HCM Platoon Ratio	1.00	1.00	1.00	1.00	1.00	1.00	1.00	1.00	1.00	1.00	1.00	1.00
Upstream Filter(I)	1.00	1.00	1.00	1.00	1.00	1.00	1.00	1.00	1.00	1.00	1.00	1.00
Uniform Delay (d), s/veh	34.8	21.8	19.3	40.8	30.6	24.5	38.8	30.8	24.2	40.5	31.1	29.8
Incr Delay (d2), s/veh	6.5	2.6	0.6	3.3	3.9	0.2	3.2	4.0	0.1	8.4	1.9	1.2
Initial Q Delay(d3),s/veh	0.0	0.0	0.0	0.0	0.0	0.0	0.0	0.0	0.0	0.0	0.0	0.0
%ile BackOfQ(50%),veh/ln	6.6	9.2	4.5	1.0	8.8	1.0	2.9	8.6	0.4	2.1	5.9	3.6
Unsig. Movement Delay, s/veh												
LnGrp Delay(d),s/veh	41.4	24.4	19.8	44.1	34.4	24.6	42.0	34.8	24.3	48.9	33.0	31.0
LnGrp LOS	D	C	B	D	C	C	D	C	C	D	C	C
Approach Vol, veh/h		1164			542			726			590	
Approach Delay, s/veh		27.5			34.1			37.2			34.7	
Approach LOS		C			C			D			C	
Timer - Assigned Phs	1	2	3	4	5	6	7	8				
Phs Duration (G+Y+Rc), s	9.5	41.3	12.9	25.6	21.8	29.0	9.9	28.6				
Change Period (Y+Rc), s	4.5	4.5	3.5	4.5	4.5	4.5	3.5	4.5				
Max Green Setting (Gmax), s	38.0	39.5	15.5	35.0	35.0	42.5	8.3	42.2				
Max Q Clear Time (g_c+I1), s	4.2	23.7	8.9	15.2	16.5	21.5	6.4	21.2				
Green Ext Time (p_c), s	0.1	4.1	0.5	2.2	0.8	2.6	0.0	2.4				
<b>Intersection Summary</b>												
HCM 6th Ctrl Delay			32.4									
HCM 6th LOS			C									



















HCM 6th Signalized Intersection Summary 2028 Opening Year Alter. A Conditions Mitigations  
 2: Shiloh Road & Hembree Ln Timing Plan: P.M. Peak

												
Movement	EBL	EBT	EBR	WBL	WBT	WBR	NBL	NBT	NBR	SBL	SBT	SBR
Lane Configurations	 			 	 						 	 
Traffic Volume (veh/h)	700	968	44	24	695	165	65	11	15	194	11	565
Future Volume (veh/h)	700	968	44	24	695	165	65	11	15	194	11	565
Initial Q (Qb), veh	0	0	0	0	0	0	0	0	0	0	0	0
Ped-Bike Adj(A_pbT)	1.00		1.00	1.00		1.00	1.00		1.00	1.00		1.00
Parking Bus, Adj	1.00	1.00	1.00	1.00	1.00	1.00	1.00	1.00	1.00	1.00	1.00	1.00
Work Zone On Approach		No			No			No			No	
Adj Sat Flow, veh/h/ln	1870	1870	1870	1870	1870	1870	1870	1870	1870	1870	1870	1870
Adj Flow Rate, veh/h	745	1030	44	24	799	190	65	11	15	204	11	595
Peak Hour Factor	0.94	0.94	1.00	1.00	0.87	0.87	1.00	1.00	1.00	0.95	1.00	0.95
Percent Heavy Veh, %	2	2	2	2	2	2	2	2	2	2	2	2
Cap, veh/h	798	1061	45	44	1110	264	92	37	51	270	15	619
Arrive On Green	0.23	0.60	0.60	0.02	0.39	0.39	0.05	0.05	0.05	0.16	0.16	0.16
Sat Flow, veh/h	3456	1781	76	1781	2847	677	1781	717	978	1694	91	1585
Grp Volume(v), veh/h	745	0	1074	24	499	490	65	0	26	215	0	595
Grp Sat Flow(s),veh/h/ln	1728	0	1857	1781	1777	1747	1781	0	1694	1786	0	1585
Q Serve(g_s), s	20.1	0.0	52.8	1.3	22.7	22.7	3.4	0.0	1.4	11.0	0.0	15.2
Cycle Q Clear(g_c), s	20.1	0.0	52.8	1.3	22.7	22.7	3.4	0.0	1.4	11.0	0.0	15.2
Prop In Lane	1.00		0.04	1.00		0.39	1.00		0.58	0.95		1.00
Lane Grp Cap(c), veh/h	798	0	1107	44	693	681	92	0	88	285	0	619
V/C Ratio(X)	0.93	0.00	0.97	0.55	0.72	0.72	0.70	0.00	0.30	0.75	0.00	0.96
Avail Cap(c_a), veh/h	798	0	1124	105	770	757	103	0	98	285	0	619
HCM Platoon Ratio	1.00	1.00	1.00	1.00	1.00	1.00	1.00	1.00	1.00	1.00	1.00	1.00
Upstream Filter(I)	1.00	0.00	1.00	1.00	1.00	1.00	1.00	0.00	1.00	1.00	0.00	1.00
Uniform Delay (d), s/veh	35.9	0.0	18.4	45.9	24.7	24.7	44.5	0.0	43.5	38.3	0.0	28.3
Incr Delay (d2), s/veh	17.8	0.0	19.9	10.1	2.9	3.0	17.4	0.0	1.9	10.9	0.0	26.8
Initial Q Delay(d3),s/veh	0.0	0.0	0.0	0.0	0.0	0.0	0.0	0.0	0.0	0.0	0.0	0.0
%ile BackOfQ(50%),veh/ln	10.1	0.0	24.8	0.7	9.5	9.3	1.9	0.0	0.6	5.5	0.0	17.2
Unsig. Movement Delay, s/veh												
LnGrp Delay(d),s/veh	53.7	0.0	38.4	56.1	27.6	27.6	61.9	0.0	45.4	49.1	0.0	55.1
LnGrp LOS	D	A	D	E	C	C	E	A	D	D	A	E
Approach Vol, veh/h		1819			1013			91				810
Approach Delay, s/veh		44.6			28.3			57.1				53.5
Approach LOS		D			C			E				D
Timer - Assigned Phs	1	2		4	5	6		8				
Phs Duration (G+Y+Rc), s	6.4	60.8		19.2	26.0	41.1		8.9				
Change Period (Y+Rc), s	4.0	4.0		4.0	4.0	4.0		4.0				
Max Green Setting (Gmax), s	5.6	57.7		15.2	22.0	41.3		5.5				
Max Q Clear Time (g_c+I1), s	3.3	54.8		17.2	22.1	24.7		5.4				
Green Ext Time (p_c), s	0.0	2.0		0.0	0.0	5.7		0.0				
<b>Intersection Summary</b>												
HCM 6th Ctrl Delay			42.4									
HCM 6th LOS			D									

# HCM 6th Signalized Intersection Summary 2028 Opening Year Alter. A Conditions Mitigations

## 7: Driveway 1/Gridley Drive & Shiloh Road

Timing Plan: P.M. Peak

												
Movement	EBL	EBT	EBR	WBL	WBT	WBR	NBL	NBT	NBR	SBL	SBT	SBR
Lane Configurations												
Traffic Volume (veh/h)	19	486	121	0	400	0	84	0	0	0	0	16
Future Volume (veh/h)	19	486	121	0	400	0	84	0	0	0	0	16
Initial Q (Qb), veh	0	0	0	0	0	0	0	0	0	0	0	0
Ped-Bike Adj(A_pbT)	1.00		0.99	1.00		1.00	1.00		1.00	1.00		1.00
Parking Bus, Adj	1.00	1.00	1.00	1.00	1.00	1.00	1.00	1.00	1.00	1.00	1.00	1.00
Work Zone On Approach		No			No			No			No	
Adj Sat Flow, veh/h/ln	1870	1870	1870	1870	1870	1870	1870	1870	1870	1870	1870	1870
Adj Flow Rate, veh/h	20	517	129	0	580	0	84	0	0	0	0	28
Peak Hour Factor	0.94	0.94	0.94	0.69	0.69	0.69	1.00	1.00	1.00	0.58	0.58	0.58
Percent Heavy Veh, %	2	2	2	2	2	2	2	2	2	2	2	2
Cap, veh/h	119	758	654	0	782	0	591	541	0	0	0	459
Arrive On Green	0.42	0.42	0.42	0.00	0.42	0.00	0.29	0.00	0.00	0.00	0.00	0.29
Sat Flow, veh/h	25	1813	1564	0	1870	0	1382	1870	0	0	0	1585
Grp Volume(v), veh/h	537	0	129	0	580	0	84	0	0	0	0	28
Grp Sat Flow(s),veh/h/ln	1838	0	1564	0	1870	0	1382	1870	0	0	0	1585
Q Serve(g_s), s	0.0	0.0	1.8	0.0	9.0	0.0	1.6	0.0	0.0	0.0	0.0	0.4
Cycle Q Clear(g_c), s	9.0	0.0	1.8	0.0	9.0	0.0	2.1	0.0	0.0	0.0	0.0	0.4
Prop In Lane	0.04		1.00	0.00		0.00	1.00		0.00	0.00		1.00
Lane Grp Cap(c), veh/h	877	0	654	0	782	0	591	541	0	0	0	459
V/C Ratio(X)	0.61	0.00	0.20	0.00	0.74	0.00	0.14	0.00	0.00	0.00	0.00	0.06
Avail Cap(c_a), veh/h	1506	0	1204	0	1440	0	1123	1261	0	0	0	1069
HCM Platoon Ratio	1.00	1.00	1.00	1.00	1.00	1.00	1.00	1.00	1.00	1.00	1.00	1.00
Upstream Filter(I)	1.00	0.00	1.00	0.00	1.00	0.00	1.00	0.00	0.00	0.00	0.00	1.00
Uniform Delay (d), s/veh	8.2	0.0	6.4	0.0	8.5	0.0	9.6	0.0	0.0	0.0	0.0	8.9
Incr Delay (d2), s/veh	0.7	0.0	0.1	0.0	1.4	0.0	0.1	0.0	0.0	0.0	0.0	0.1
Initial Q Delay(d3),s/veh	0.0	0.0	0.0	0.0	0.0	0.0	0.0	0.0	0.0	0.0	0.0	0.0
%ile BackOfQ(50%),veh/ln	1.8	0.0	0.3	0.0	2.2	0.0	0.4	0.0	0.0	0.0	0.0	0.1
Unsig. Movement Delay, s/veh												
LnGrp Delay(d),s/veh	8.9	0.0	6.5	0.0	9.9	0.0	9.7	0.0	0.0	0.0	0.0	8.9
LnGrp LOS	A	A	A	A	A	A	A	A	A	A	A	A
Approach Vol, veh/h		666			580			84				28
Approach Delay, s/veh		8.4			9.9			9.7				8.9
Approach LOS		A			A			A				A
Timer - Assigned Phs		2		4		6		8				
Phs Duration (G+Y+Rc), s		14.7		19.8		14.7		19.8				
Change Period (Y+Rc), s		* 4.7		5.4		* 4.7		5.4				
Max Green Setting (Gmax), s		* 23		26.6		* 23		26.6				
Max Q Clear Time (g_c+I1), s		4.1		11.0		2.4		11.0				
Green Ext Time (p_c), s		0.2		3.4		0.1		3.2				

### Intersection Summary

HCM 6th Ctrl Delay	9.1
HCM 6th LOS	A

### Notes

\* HCM 6th computational engine requires equal clearance times for the phases crossing the barrier.

HCM 6th Signalized Intersection Summary 2028 Opening Year Alter. A Conditions Mitigations  
 8: Old Redwood Hwy & Driveway 2 Timing Plan: P.M. Peak



Movement	EBL	EBT	EBR	WBL	WBT	WBR	NBL	NBT	NBR	SBL	SBT	SBR
Lane Configurations		↔		↖	↗			↖	↗	↖	↗	
Traffic Volume (veh/h)	3	0	0	49	0	79	0	575	71	114	486	0
Future Volume (veh/h)	3	0	0	49	0	79	0	575	71	114	486	0
Initial Q (Qb), veh	0	0	0	0	0	0	0	0	0	0	0	0
Ped-Bike Adj(A_pbT)	1.00		1.00	1.00		1.00	1.00		0.99	1.00		1.00
Parking Bus, Adj	1.00	1.00	1.00	1.00	1.00	1.00	1.00	1.00	1.00	1.00	1.00	1.00
Work Zone On Approach		No			No			No			No	
Adj Sat Flow, veh/h/ln	1870	1870	1870	1870	1870	1870	1870	1870	1870	1870	1870	1870
Adj Flow Rate, veh/h	8	0	0	49	0	79	0	632	78	121	517	0
Peak Hour Factor	0.38	0.38	0.38	1.00	1.00	1.00	0.91	0.91	0.91	0.94	0.94	0.94
Percent Heavy Veh, %	2	2	2	2	2	2	2	2	2	2	2	2
Cap, veh/h	397	0	0	490	0	317	0	981	821	397	981	0
Arrive On Green	0.20	0.00	0.00	0.20	0.00	0.20	0.00	0.52	0.52	0.52	0.52	0.00
Sat Flow, veh/h	1043	0	0	1418	0	1585	0	1870	1564	739	1870	0
Grp Volume(v), veh/h	8	0	0	49	0	79	0	632	78	121	517	0
Grp Sat Flow(s),veh/h/ln	1043	0	0	1418	0	1585	0	1870	1564	739	1870	0
Q Serve(g_s), s	0.2	0.0	0.0	0.0	0.0	1.6	0.0	9.3	1.0	5.4	6.9	0.0
Cycle Q Clear(g_c), s	1.8	0.0	0.0	0.9	0.0	1.6	0.0	9.3	1.0	14.6	6.9	0.0
Prop In Lane	1.00		0.00	1.00		1.00	0.00		1.00	1.00		0.00
Lane Grp Cap(c), veh/h	397	0	0	490	0	317	0	981	821	397	981	0
V/C Ratio(X)	0.02	0.00	0.00	0.10	0.00	0.25	0.00	0.64	0.10	0.30	0.53	0.00
Avail Cap(c_a), veh/h	756	0	0	875	0	748	0	1544	1291	620	1544	0
HCM Platoon Ratio	1.00	1.00	1.00	1.00	1.00	1.00	1.00	1.00	1.00	1.00	1.00	1.00
Upstream Filter(I)	1.00	0.00	0.00	1.00	0.00	1.00	0.00	1.00	1.00	1.00	1.00	0.00
Uniform Delay (d), s/veh	13.6	0.0	0.0	12.6	0.0	12.8	0.0	6.5	4.5	11.8	6.0	0.0
Incr Delay (d2), s/veh	0.0	0.0	0.0	0.1	0.0	0.4	0.0	0.7	0.0	0.4	0.4	0.0
Initial Q Delay(d3),s/veh	0.0	0.0	0.0	0.0	0.0	0.0	0.0	0.0	0.0	0.0	0.0	0.0
%ile BackOfQ(50%),veh/ln	0.1	0.0	0.0	0.3	0.0	0.5	0.0	1.6	0.1	0.6	1.2	0.0
Unsig. Movement Delay, s/veh												
LnGrp Delay(d),s/veh	13.6	0.0	0.0	12.6	0.0	13.3	0.0	7.2	4.6	12.2	6.4	0.0
LnGrp LOS	B	A	A	B	A	B	A	A	A	B	A	A
Approach Vol, veh/h		8			128			710			638	
Approach Delay, s/veh		13.6			13.0			6.9			7.5	
Approach LOS		B			B			A			A	
Timer - Assigned Phs		2		4		6		8				
Phs Duration (G+Y+Rc), s		25.8		12.3		25.8		12.3				
Change Period (Y+Rc), s		5.8		* 4.7		5.8		* 4.7				
Max Green Setting (Gmax), s		31.5		* 18		31.5		* 18				
Max Q Clear Time (g_c+I1), s		11.3		3.8		16.6		3.6				
Green Ext Time (p_c), s		4.0		0.0		3.4		0.4				

**Intersection Summary**

HCM 6th Ctrl Delay	7.7
HCM 6th LOS	A

























**Notes**

\* HCM 6th computational engine requires equal clearance times for the phases crossing the barrier.  
 User approved changes to right turn type.



























HCM 6th Signalized Intersection Summary 2028 Opening Year Alter. A Conditions Mitigations  
 1: Old Redwood Hwy & Shiloh Road

Timing Plan: Saturday Midday Peak

												
Movement	EBL	EBT	EBR	WBL	WBT	WBR	NBL	NBT	NBR	SBL	SBT	SBR
Lane Configurations												
Traffic Volume (veh/h)	156	484	289	24	500	71	296	280	27	76	229	239
Future Volume (veh/h)	156	484	289	24	500	71	296	280	27	76	229	239
Initial Q (Qb), veh	0	0	0	0	0	0	0	0	0	0	0	0
Ped-Bike Adj(A_pbT)	1.00		0.97	1.00		1.00	1.00		0.98	1.00		0.98
Parking Bus, Adj	1.00	1.00	1.00	1.00	1.00	1.00	1.00	1.00	1.00	1.00	1.00	1.00
Work Zone On Approach		No			No			No			No	
Adj Sat Flow, veh/h/ln	1870	1870	1870	1870	1870	1870	1870	1870	1870	1870	1870	1870
Adj Flow Rate, veh/h	175	544	325	28	581	83	318	301	29	84	252	263
Peak Hour Factor	0.89	0.89	0.89	0.86	0.86	0.86	0.93	0.93	0.93	0.91	0.91	0.91
Percent Heavy Veh, %	2	2	2	2	2	2	2	2	2	2	2	2
Cap, veh/h	218	792	654	99	667	565	408	480	398	122	388	323
Arrive On Green	0.12	0.42	0.42	0.06	0.36	0.36	0.12	0.26	0.26	0.07	0.21	0.21
Sat Flow, veh/h	1781	1870	1545	1781	1870	1585	3456	1870	1551	1781	1870	1558
Grp Volume(v), veh/h	175	544	325	28	581	83	318	301	29	84	252	263
Grp Sat Flow(s),veh/h/ln	1781	1870	1545	1781	1870	1585	1728	1870	1551	1781	1870	1558
Q Serve(g_s), s	8.6	21.2	13.8	1.4	26.0	3.2	8.0	12.8	1.3	4.1	11.1	14.4
Cycle Q Clear(g_c), s	8.6	21.2	13.8	1.4	26.0	3.2	8.0	12.8	1.3	4.1	11.1	14.4
Prop In Lane	1.00		1.00	1.00		1.00	1.00		1.00	1.00		1.00
Lane Grp Cap(c), veh/h	218	792	654	99	667	565	408	480	398	122	388	323
V/C Ratio(X)	0.80	0.69	0.50	0.28	0.87	0.15	0.78	0.63	0.07	0.69	0.65	0.81
Avail Cap(c_a), veh/h	599	804	664	756	969	821	617	898	745	159	731	609
HCM Platoon Ratio	1.00	1.00	1.00	1.00	1.00	1.00	1.00	1.00	1.00	1.00	1.00	1.00
Upstream Filter(I)	1.00	1.00	1.00	1.00	1.00	1.00	1.00	1.00	1.00	1.00	1.00	1.00
Uniform Delay (d), s/veh	38.2	21.0	18.8	40.6	26.9	19.6	38.4	29.5	25.2	40.8	32.5	33.9
Incr Delay (d2), s/veh	6.7	2.4	0.6	1.5	6.1	0.1	3.6	1.4	0.1	7.9	1.8	5.0
Initial Q Delay(d3),s/veh	0.0	0.0	0.0	0.0	0.0	0.0	0.0	0.0	0.0	0.0	0.0	0.0
%ile BackOfQ(50%),veh/ln	4.0	9.0	4.5	0.6	11.8	1.1	3.4	5.5	0.4	2.0	5.0	5.6
Unsig. Movement Delay, s/veh												
LnGrp Delay(d),s/veh	44.9	23.4	19.4	42.1	33.0	19.7	42.0	30.9	25.3	48.7	34.4	38.8
LnGrp LOS	D	C	B	D	C	B	D	C	C	D	C	D
Approach Vol, veh/h		1044			692			648			599	
Approach Delay, s/veh		25.8			31.8			36.1			38.3	
Approach LOS		C			C			D			D	
Timer - Assigned Phs	1	2	3	4	5	6	7	8				
Phs Duration (G+Y+Rc), s	9.5	42.4	14.6	23.1	15.5	36.4	10.2	27.5				
Change Period (Y+Rc), s	4.5	4.5	4.0	4.5	4.5	4.5	4.0	4.5				
Max Green Setting (Gmax), s	38.0	38.5	16.0	35.0	30.1	46.4	8.0	43.0				
Max Q Clear Time (g_c+I1), s	3.4	23.2	10.0	16.4	10.6	28.0	6.1	14.8				
Green Ext Time (p_c), s	0.0	4.0	0.6	2.1	0.4	3.7	0.0	1.7				
<b>Intersection Summary</b>												
HCM 6th Ctrl Delay											31.9	
HCM 6th LOS											C	



















HCM 6th Signalized Intersection Summary 2028 Opening Year Alter. A Conditions Mitigations  
 2: Shiloh Road & Hembree Ln

Timing Plan: Saturday Midday Peak

												
Movement	EBL	EBT	EBR	WBL	WBT	WBR	NBL	NBT	NBR	SBL	SBT	SBR
Lane Configurations	 			 	 						 	
Traffic Volume (veh/h)	708	852	44	24	792	185	65	11	15	182	11	666
Future Volume (veh/h)	708	852	44	24	792	185	65	11	15	182	11	666
Initial Q (Qb), veh	0	0	0	0	0	0	0	0	0	0	0	0
Ped-Bike Adj(A_pbT)	1.00		1.00	1.00		1.00	1.00		1.00	1.00		1.00
Parking Bus, Adj	1.00	1.00	1.00	1.00	1.00	1.00	1.00	1.00	1.00	1.00	1.00	1.00
Work Zone On Approach		No			No			No			No	
Adj Sat Flow, veh/h/ln	1870	1870	1870	1870	1870	1870	1870	1870	1870	1870	1870	1870
Adj Flow Rate, veh/h	753	906	44	24	825	193	65	11	15	200	11	732
Peak Hour Factor	0.94	0.94	1.00	1.00	0.96	0.96	1.00	1.00	1.00	0.91	1.00	0.91
Percent Heavy Veh, %	2	2	2	2	2	2	2	2	2	2	2	2
Cap, veh/h	793	952	46	43	951	222	91	37	50	395	22	734
Arrive On Green	0.23	0.54	0.54	0.02	0.33	0.33	0.05	0.05	0.05	0.23	0.23	0.23
Sat Flow, veh/h	3456	1769	86	1781	2858	668	1781	717	978	1693	93	1585
Grp Volume(v), veh/h	753	0	950	24	513	505	65	0	26	211	0	732
Grp Sat Flow(s),veh/h/ln	1728	0	1855	1781	1777	1749	1781	0	1694	1786	0	1585
Q Serve(g_s), s	22.4	0.0	50.7	1.4	28.3	28.3	3.8	0.0	1.5	10.7	0.0	24.4
Cycle Q Clear(g_c), s	22.4	0.0	50.7	1.4	28.3	28.3	3.8	0.0	1.5	10.7	0.0	24.4
Prop In Lane	1.00		0.05	1.00		0.38	1.00		0.58	0.95		1.00
Lane Grp Cap(c), veh/h	793	0	999	43	591	582	91	0	87	417	0	734
V/C Ratio(X)	0.95	0.00	0.95	0.56	0.87	0.87	0.71	0.00	0.30	0.51	0.00	1.00
Avail Cap(c_a), veh/h	793	0	1038	95	682	671	94	0	89	417	0	734
HCM Platoon Ratio	1.00	1.00	1.00	1.00	1.00	1.00	1.00	1.00	1.00	1.00	1.00	1.00
Upstream Filter(I)	1.00	0.00	1.00	1.00	1.00	1.00	1.00	0.00	1.00	1.00	0.00	1.00
Uniform Delay (d), s/veh	39.7	0.0	22.8	50.5	32.7	32.7	48.8	0.0	47.8	34.8	0.0	28.0
Incr Delay (d2), s/veh	20.5	0.0	17.1	11.0	10.4	10.5	21.9	0.0	1.9	1.0	0.0	32.5
Initial Q Delay(d3),s/veh	0.0	0.0	0.0	0.0	0.0	0.0	0.0	0.0	0.0	0.0	0.0	0.0
%ile BackOfQ(50%),veh/ln	11.4	0.0	24.4	0.7	13.3	13.1	2.2	0.0	0.7	4.7	0.0	23.9
Unsig. Movement Delay, s/veh												
LnGrp Delay(d),s/veh	60.2	0.0	40.0	61.5	43.1	43.2	70.7	0.0	49.7	35.8	0.0	60.5
LnGrp LOS	E	A	D	E	D	D	E	A	D	D	A	E
Approach Vol, veh/h		1703			1042			91				943
Approach Delay, s/veh		48.9			43.6			64.7				55.0
Approach LOS		D			D			E				E
Timer - Assigned Phs	1	2		4	5	6		8				
Phs Duration (G+Y+Rc), s	6.5	60.3		28.4	28.0	38.8		9.3				
Change Period (Y+Rc), s	4.0	4.0		4.0	4.0	4.0		4.0				
Max Green Setting (Gmax), s	5.6	58.5		24.4	24.0	40.1		5.5				
Max Q Clear Time (g_c+I1), s	3.4	52.7		26.4	24.4	30.3		5.8				
Green Ext Time (p_c), s	0.0	3.2		0.0	0.0	4.4		0.0				
<b>Intersection Summary</b>												
HCM 6th Ctrl Delay			49.3									
HCM 6th LOS			D									

HCM 6th Signalized Intersection Summary 2028 Opening Year Alter. A Conditions Mitigations  
 7: Driveway 1/Gridley Drive & Shiloh Road

Timing Plan: Saturday Midday Peak

												
Movement	EBL	EBT	EBR	WBL	WBT	WBR	NBL	NBT	NBR	SBL	SBT	SBR
Lane Configurations												
Traffic Volume (veh/h)	23	463	112	0	460	0	116	0	0	0	0	20
Future Volume (veh/h)	23	463	112	0	460	0	116	0	0	0	0	20
Initial Q (Qb), veh	0	0	0	0	0	0	0	0	0	0	0	0
Ped-Bike Adj(A_pbT)	1.00		0.99	1.00		1.00	1.00		1.00	1.00		1.00
Parking Bus, Adj	1.00	1.00	1.00	1.00	1.00	1.00	1.00	1.00	1.00	1.00	1.00	1.00
Work Zone On Approach		No			No			No			No	
Adj Sat Flow, veh/h/ln	1870	1870	1870	1870	1870	1870	1870	1870	1870	1870	1870	1870
Adj Flow Rate, veh/h	25	498	120	0	523	0	464	0	0	0	0	36
Peak Hour Factor	0.93	0.93	0.93	0.88	0.88	0.88	0.25	0.25	0.25	0.56	0.56	0.56
Percent Heavy Veh, %	2	2	2	2	2	2	2	2	2	2	2	2
Cap, veh/h	95	633	593	0	709	0	686	745	0	0	0	631
Arrive On Green	0.38	0.38	0.38	0.00	0.38	0.00	0.40	0.00	0.00	0.00	0.00	0.40
Sat Flow, veh/h	31	1670	1564	0	1870	0	1372	1870	0	0	0	1585
Grp Volume(v), veh/h	523	0	120	0	523	0	464	0	0	0	0	36
Grp Sat Flow(s),veh/h/ln	1701	0	1564	0	1870	0	1372	1870	0	0	0	1585
Q Serve(g_s), s	1.8	0.0	2.3	0.0	10.9	0.0	14.3	0.0	0.0	0.0	0.0	0.6
Cycle Q Clear(g_c), s	12.8	0.0	2.3	0.0	10.9	0.0	14.9	0.0	0.0	0.0	0.0	0.6
Prop In Lane	0.05		1.00	0.00		0.00	1.00		0.00	0.00		1.00
Lane Grp Cap(c), veh/h	728	0	593	0	709	0	686	745	0	0	0	631
V/C Ratio(X)	0.72	0.00	0.20	0.00	0.74	0.00	0.68	0.00	0.00	0.00	0.00	0.06
Avail Cap(c_a), veh/h	968	0	804	0	962	0	945	1098	0	0	0	930
HCM Platoon Ratio	1.00	1.00	1.00	1.00	1.00	1.00	1.00	1.00	1.00	1.00	1.00	1.00
Upstream Filter(I)	1.00	0.00	1.00	0.00	1.00	0.00	1.00	0.00	0.00	0.00	0.00	1.00
Uniform Delay (d), s/veh	12.3	0.0	9.5	0.0	12.1	0.0	13.0	0.0	0.0	0.0	0.0	8.4
Incr Delay (d2), s/veh	1.7	0.0	0.2	0.0	2.0	0.0	1.2	0.0	0.0	0.0	0.0	0.0
Initial Q Delay(d3),s/veh	0.0	0.0	0.0	0.0	0.0	0.0	0.0	0.0	0.0	0.0	0.0	0.0
%ile BackOfQ(50%),veh/ln	3.6	0.0	0.6	0.0	3.6	0.0	3.6	0.0	0.0	0.0	0.0	0.2
Unsig. Movement Delay, s/veh												
LnGrp Delay(d),s/veh	14.0	0.0	9.6	0.0	14.1	0.0	14.2	0.0	0.0	0.0	0.0	8.4
LnGrp LOS	B	A	A	A	B	A	B	A	A	A	A	A
Approach Vol, veh/h		643			523			464				36
Approach Delay, s/veh		13.2			14.1			14.2				8.4
Approach LOS		B			B			B				A
Timer - Assigned Phs		2		4		6		8				
Phs Duration (G+Y+Rc), s		22.7		22.6		22.7		22.6				
Change Period (Y+Rc), s		* 4.7		5.4		* 4.7		5.4				
Max Green Setting (Gmax), s		* 27		23.3		* 27		23.3				
Max Q Clear Time (g_c+I1), s		16.9		14.8		2.6		12.9				
Green Ext Time (p_c), s		1.1		2.4		0.1		2.3				

Intersection Summary

HCM 6th Ctrl Delay	13.7
HCM 6th LOS	B

Notes

\* HCM 6th computational engine requires equal clearance times for the phases crossing the barrier.

Queues  
1: Old Redwood Hwy & Shiloh Road

2028 Opening Year Alter. A Conditions  
Timing Plan: A.M. PEAK



Lane Group	EBL	EBT	EBR	WBL	WBT	WBR	NBL	NBT	NBR	SBL	SBT	SBR
Lane Group Flow (vph)	169	358	167	28	202	31	129	157	42	44	316	245
v/c Ratio	0.35	0.71	0.32	0.09	0.60	0.08	0.36	0.27	0.08	0.36	0.69	0.48
Control Delay	31.6	40.5	11.2	36.0	45.1	0.4	45.3	27.7	1.6	56.4	41.0	13.7
Queue Delay	0.0	0.0	0.0	0.0	0.0	0.0	0.0	0.0	0.0	0.0	0.0	0.0
Total Delay	31.6	40.5	11.2	36.0	45.1	0.4	45.3	27.7	1.6	56.4	41.0	13.7
Queue Length 50th (ft)	76	181	16	14	108	0	36	70	0	25	164	33
Queue Length 95th (ft)	151	315	62	43	214	0	79	139	7	68	280	98
Internal Link Dist (ft)		1709			528			668			695	
Turn Bay Length (ft)	375		175	200		50	200		98	190		130
Base Capacity (vph)	633	666	649	789	830	763	584	950	845	124	764	743
Starvation Cap Reductn	0	0	0	0	0	0	0	0	0	0	0	0
Spillback Cap Reductn	0	0	0	0	0	0	0	0	0	0	0	0
Storage Cap Reductn	0	0	0	0	0	0	0	0	0	0	0	0
Reduced v/c Ratio	0.27	0.54	0.26	0.04	0.24	0.04	0.22	0.17	0.05	0.35	0.41	0.33

Intersection Summary

Queues

2028 Opening Year Alter. A Conditions

2: Shiloh Road & Hembree Ln

Timing Plan: A.M. PEAK

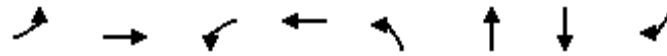

Lane Group	EBL	EBT	WBL	WBT	NBL	NBT	SBT	SBR
Lane Group Flow (vph)	394	619	19	565	39	18	95	439
v/c Ratio	0.52	0.57	0.10	0.53	0.20	0.09	0.34	0.52
Control Delay	25.4	11.3	34.1	17.7	34.8	24.3	31.5	6.7
Queue Delay	0.0	0.0	0.0	0.0	0.0	0.0	0.0	0.0
Total Delay	25.4	11.3	34.1	17.7	34.8	24.3	31.5	6.7
Queue Length 50th (ft)	64	135	6	87	13	2	31	18
Queue Length 95th (ft)	144	286	32	137	53	25	98	112
Internal Link Dist (ft)		222		1709		136	301	
Turn Bay Length (ft)			100					
Base Capacity (vph)	1146	1597	191	2648	191	192	350	981
Starvation Cap Reductn	0	0	0	0	0	0	0	0
Spillback Cap Reductn	0	0	0	0	0	0	0	0
Storage Cap Reductn	0	0	0	0	0	0	0	0
Reduced v/c Ratio	0.34	0.39	0.10	0.21	0.20	0.09	0.27	0.45

Intersection Summary

Queues  
7: Driveway 1/Gridley Drive & Shiloh Road

2028 Opening Year Alter. A Conditions  
Timing Plan: A.M. PEAK

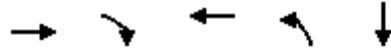

Lane Group	EBT	EBR	WBT	NBL	SBT
Lane Group Flow (vph)	346	52	196	33	26
v/c Ratio	0.49	0.08	0.27	0.09	0.06
Control Delay	8.5	2.2	6.3	9.2	3.8
Queue Delay	0.0	0.0	0.0	0.0	0.0
Total Delay	8.5	2.2	6.3	9.2	3.8
Queue Length 50th (ft)	27	0	14	3	0
Queue Length 95th (ft)	62	8	32	15	5
Internal Link Dist (ft)	528		2066		635
Turn Bay Length (ft)		150			
Base Capacity (vph)	1285	1107	1301	962	1131
Starvation Cap Reductn	0	0	0	0	0
Spillback Cap Reductn	0	0	0	0	0
Storage Cap Reductn	0	0	0	0	0
Reduced v/c Ratio	0.27	0.05	0.15	0.03	0.02
Intersection Summary					

Queues  
8: Old Redwood Hwy & Driveway 2

2028 Opening Year Alter. A Conditions  
Timing Plan: A.M. PEAK



Lane Group	EBT	WBL	WBT	NBT	NBR	SBL	SBT
Lane Group Flow (vph)	4	19	31	249	28	50	400
v/c Ratio	0.01	0.05	0.04	0.16	0.02	0.05	0.26
Control Delay	12.0	12.2	0.1	2.9	1.6	3.1	3.3
Queue Delay	0.0	0.0	0.0	0.0	0.0	0.0	0.0
Total Delay	12.0	12.2	0.1	2.9	1.6	3.1	3.3
Queue Length 50th (ft)	1	2	0	0	0	0	0
Queue Length 95th (ft)	1	12	0	41	5	12	69
Internal Link Dist (ft)	18		305	440			668
Turn Bay Length (ft)					100	50	
Base Capacity (vph)	1120	1120	1145	1546	1319	934	1546
Starvation Cap Reductn	0	0	0	0	0	0	0
Spillback Cap Reductn	0	0	0	0	0	0	0
Storage Cap Reductn	0	0	0	0	0	0	0
Reduced v/c Ratio	0.00	0.02	0.03	0.16	0.02	0.05	0.26
<b>Intersection Summary</b>							

Queues  
1: Old Redwood Hwy & Shiloh Road

2028+P Alternative A\_Mitigations

Timing Plan: P.M. Peak



Lane Group	EBL	EBT	EBR	WBL	WBT	WBR	NBL	NBT	NBR	SBL	SBT	SBR
Lane Group Flow (vph)	299	547	318	46	433	63	274	426	26	89	304	197
v/c Ratio	0.78	0.66	0.40	0.35	0.83	0.12	0.67	0.83	0.05	0.68	0.71	0.43
Control Delay	60.3	31.7	13.2	66.1	56.0	2.5	61.8	56.6	0.2	84.5	54.3	18.8
Queue Delay	0.0	0.0	0.0	0.0	0.0	0.0	0.0	0.0	0.0	0.0	0.0	0.0
Total Delay	60.3	31.7	13.2	66.1	56.1	2.5	61.8	56.6	0.2	84.5	54.3	18.8
Queue Length 50th (ft)	218	332	77	34	311	0	104	306	0	68	219	42
Queue Length 95th (ft)	370	533	173	85	515	12	#184	506	0	#193	370	126
Internal Link Dist (ft)		1709			528			668			695	
Turn Bay Length (ft)	375		175	200		50	200		98	190		130
Base Capacity (vph)	554	834	796	601	709	650	476	703	628	131	583	577
Starvation Cap Reductn	0	0	0	0	5	0	0	0	0	0	0	0
Spillback Cap Reductn	0	0	0	0	0	0	0	0	0	0	0	0
Storage Cap Reductn	0	0	0	0	0	0	0	0	0	0	0	0
Reduced v/c Ratio	0.54	0.66	0.40	0.08	0.62	0.10	0.58	0.61	0.04	0.68	0.52	0.34

Intersection Summary

# 95th percentile volume exceeds capacity, queue may be longer.  
Queue shown is maximum after two cycles.



Queues

2: Shiloh Road & Hembree Ln

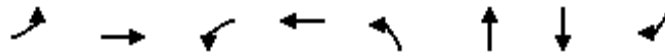

Lane Group	EBL	EBT	WBL	WBT	NBL	NBT	SBT	SBR
Lane Group Flow (vph)	745	1074	24	989	65	26	215	595
v/c Ratio	0.90	0.93	0.22	0.75	0.61	0.22	0.72	0.82
Control Delay	50.4	32.1	49.3	28.0	69.8	32.3	53.6	28.9
Queue Delay	0.0	9.6	0.0	0.0	0.0	0.0	0.0	0.0
Total Delay	50.4	41.6	49.3	28.0	69.8	32.3	53.6	28.9
Queue Length 50th (ft)	214	473	13	257	37	6	119	183
Queue Length 95th (ft)	#368	#967	41	313	#110	34	#252	#499
Internal Link Dist (ft)		222		1709		136	301	
Turn Bay Length (ft)			100					
Base Capacity (vph)	831	1180	109	1576	107	116	297	722
Starvation Cap Reductn	0	100	0	0	0	0	0	0
Spillback Cap Reductn	0	0	0	0	0	0	0	0
Storage Cap Reductn	0	0	0	0	0	0	0	0
Reduced v/c Ratio	0.90	0.99	0.22	0.63	0.61	0.22	0.72	0.82

Intersection Summary

# 95th percentile volume exceeds capacity, queue may be longer.  
 Queue shown is maximum after two cycles.

Queues  
3: US 101 NB Off-Ramp & Shiloh Road

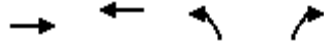

Lane Group	EBT	WBT	NBL	NBR
Lane Group Flow (vph)	689	944	666	1188
v/c Ratio	0.42	1.09	0.90	0.69
Control Delay	13.8	79.1	36.3	13.9
Queue Delay	0.0	0.0	0.0	0.0
Total Delay	13.8	79.1	36.3	13.9
Queue Length 50th (ft)	103	-489	260	124
Queue Length 95th (ft)	144	#703	#461	181
Internal Link Dist (ft)	106	291	689	
Turn Bay Length (ft)				265
Base Capacity (vph)	1651	869	776	1776
Starvation Cap Reductn	0	0	0	0
Spillback Cap Reductn	0	0	0	0
Storage Cap Reductn	0	0	0	0
Reduced v/c Ratio	0.42	1.09	0.86	0.67

Intersection Summary

- ~ Volume exceeds capacity, queue is theoretically infinite.  
Queue shown is maximum after two cycles.
- # 95th percentile volume exceeds capacity, queue may be longer.  
Queue shown is maximum after two cycles.

Queues

4: Shiloh Road & US 101 SB Off-Ramp

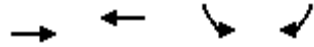

Lane Group	EBT	WBT	SBL	SBR
Lane Group Flow (vph)	599	770	342	157
v/c Ratio	0.63	0.80	0.59	0.26
Control Delay	11.9	17.5	22.8	5.1
Queue Delay	0.0	0.0	0.0	0.0
Total Delay	11.9	17.5	22.8	5.1
Queue Length 50th (ft)	117	174	85	0
Queue Length 95th (ft)	185	285	#237	39
Internal Link Dist (ft)	145	226	406	
Turn Bay Length (ft)				275
Base Capacity (vph)	1863	1863	584	615
Starvation Cap Reductn	0	0	0	0
Spillback Cap Reductn	0	0	0	0
Storage Cap Reductn	0	0	0	0
Reduced v/c Ratio	0.32	0.41	0.59	0.26

Intersection Summary

# 95th percentile volume exceeds capacity, queue may be longer.  
 Queue shown is maximum after two cycles.

Queues  
6: Conde Lane & Shiloh Road

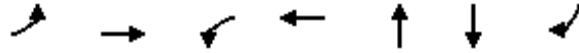

Lane Group	EBL	EBT	WBL	WBT	NBT	SBT	SBR
Lane Group Flow (vph)	90	650	10	1091	45	384	50
v/c Ratio	0.35	0.34	0.04	0.73	0.14	1.15	0.07
Control Delay	37.8	9.8	35.2	17.7	19.1	132.1	13.3
Queue Delay	0.0	0.0	0.0	0.0	0.0	0.0	0.0
Total Delay	37.8	9.8	35.2	17.7	19.1	132.1	13.3
Queue Length 50th (ft)	41	78	5	204	7	~264	14
Queue Length 95th (ft)	92	150	18	224	22	#471	33
Internal Link Dist (ft)		735		1001	338	442	
Turn Bay Length (ft)	90		127				40
Base Capacity (vph)	273	2435	242	2209	960	333	1034
Starvation Cap Reductn	0	0	0	0	0	0	0
Spillback Cap Reductn	0	0	0	0	0	0	0
Storage Cap Reductn	0	0	0	0	0	0	0
Reduced v/c Ratio	0.33	0.27	0.04	0.49	0.05	1.15	0.05

Intersection Summary

- ~ Volume exceeds capacity, queue is theoretically infinite.  
Queue shown is maximum after two cycles.
- # 95th percentile volume exceeds capacity, queue may be longer.  
Queue shown is maximum after two cycles.

Queues  
7: Driveway 1/Gridley Drive & Shiloh Road

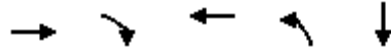

Lane Group	EBT	EBR	WBT	NBL	SBT
Lane Group Flow (vph)	537	129	580	84	28
v/c Ratio	0.66	0.17	0.70	0.22	0.05
Control Delay	12.4	2.0	13.0	14.5	0.1
Queue Delay	0.0	0.0	0.0	0.0	0.0
Total Delay	12.4	2.0	13.0	14.5	0.1
Queue Length 50th (ft)	75	0	82	13	0
Queue Length 95th (ft)	147	16	103	47	0
Internal Link Dist (ft)	528		2066		635
Turn Bay Length (ft)		150			
Base Capacity (vph)	1306	1167	1348	873	1093
Starvation Cap Reductn	0	0	0	0	0
Spillback Cap Reductn	0	0	0	0	0
Storage Cap Reductn	0	0	0	0	0
Reduced v/c Ratio	0.41	0.11	0.43	0.10	0.03
Intersection Summary					

Queues  
8: Old Redwood Hwy & Driveway 2

2028+P Alternative A\_Mitigations  
Timing Plan: P.M. Peak



Lane Group	EBT	WBL	WBT	NBT	NBR	SBL	SBT
Lane Group Flow (vph)	8	49	79	632	78	121	517
v/c Ratio	0.03	0.15	0.14	0.53	0.08	0.28	0.43
Control Delay	14.7	16.1	0.5	8.6	1.7	7.9	7.4
Queue Delay	0.0	0.0	0.0	0.0	0.0	0.0	0.0
Total Delay	14.7	16.1	0.5	8.6	1.7	7.9	7.4
Queue Length 50th (ft)	1	9	0	96	0	15	72
Queue Length 95th (ft)	4	34	0	170	11	40	127
Internal Link Dist (ft)	18		305	440			668
Turn Bay Length (ft)					100	50	
Base Capacity (vph)	568	605	813	1400	1193	504	1400
Starvation Cap Reductn	0	0	0	0	0	0	0
Spillback Cap Reductn	0	0	0	0	0	0	0
Storage Cap Reductn	0	0	0	0	0	0	0
Reduced v/c Ratio	0.01	0.08	0.10	0.45	0.07	0.24	0.37
<b>Intersection Summary</b>							

Queues

10: US 101 NB Off Ramp/Lakewood Drive & Old Redwood Highway



Lane Group	EBL	EBT	WBT	NBL	NBT	SBL	SBR
Lane Group Flow (vph)	341	540	917	482	957	296	684
v/c Ratio	0.99	0.65	0.86	0.93	0.88	1.11	0.77
Control Delay	89.6	23.9	37.9	56.9	37.7	127.8	18.5
Queue Delay	0.0	0.0	0.0	0.0	0.0	0.0	0.0
Total Delay	89.6	23.9	37.9	56.9	37.7	127.8	18.5
Queue Length 50th (ft)	101	232	243	289	259	~100	193
Queue Length 95th (ft)	#179	326	#351	#498	#381	#181	350
Internal Link Dist (ft)		146	537		636		
Turn Bay Length (ft)	155			270		120	
Base Capacity (vph)	343	832	1061	518	1082	267	890
Starvation Cap Reductn	0	0	0	0	0	0	0
Spillback Cap Reductn	0	0	0	0	0	0	0
Storage Cap Reductn	0	0	0	0	0	0	0
Reduced v/c Ratio	0.99	0.65	0.86	0.93	0.88	1.11	0.77

Intersection Summary

~ Volume exceeds capacity, queue is theoretically infinite.  
 Queue shown is maximum after two cycles.

# 95th percentile volume exceeds capacity, queue may be longer.  
 Queue shown is maximum after two cycles.

Queues

12: US 101 SB On Ramp/US 101 SB Off Ramp & Old Redwood Highway



Lane Group	EBT	EBR	WBL	WBT	SBL	SBT
Lane Group Flow (vph)	648	462	488	1310	257	234
v/c Ratio	0.46	0.52	1.07	0.52	1.04	0.76
Control Delay	16.8	4.1	91.7	5.5	101.9	34.9
Queue Delay	0.0	0.0	0.0	0.0	0.0	0.0
Total Delay	16.8	4.1	91.7	5.5	101.9	34.9
Queue Length 50th (ft)	104	2	~239	107	~128	60
Queue Length 95th (ft)	148	55	#403	141	#237	#142
Internal Link Dist (ft)	343			451		751
Turn Bay Length (ft)			250		420	
Base Capacity (vph)	1410	893	455	2522	247	309
Starvation Cap Reductn	0	0	0	0	0	0
Spillback Cap Reductn	0	0	0	0	0	0
Storage Cap Reductn	0	0	0	0	0	0
Reduced v/c Ratio	0.46	0.52	1.07	0.52	1.04	0.76

Intersection Summary

~ Volume exceeds capacity, queue is theoretically infinite.  
Queue shown is maximum after two cycles.

# 95th percentile volume exceeds capacity, queue may be longer.  
Queue shown is maximum after two cycles.



Queues  
1: Old Redwood Hwy & Shiloh Road

2028+P Alternative A\_Mitigations  
Timing Plan: Saturday Midday Peak



Lane Group	EBL	EBT	EBR	WBL	WBT	WBR	NBL	NBT	NBR	SBL	SBT	SBR
Lane Group Flow (vph)	175	544	325	28	581	83	318	301	29	84	252	263
v/c Ratio	0.67	0.58	0.38	0.24	0.83	0.13	0.71	0.65	0.06	0.67	0.72	0.57
Control Delay	61.5	26.0	11.5	62.0	46.0	3.6	59.9	46.8	0.3	82.4	57.3	15.4
Queue Delay	0.0	0.0	0.0	0.0	1.1	0.0	0.0	0.0	0.0	0.0	0.0	0.0
Total Delay	61.5	26.0	11.5	62.0	47.1	3.6	59.9	46.8	0.3	82.4	57.3	15.4
Queue Length 50th (ft)	128	299	72	21	385	0	120	207	0	64	184	33
Queue Length 95th (ft)	221	500	168	54	#672	20	#212	325	0	#174	294	120
Internal Link Dist (ft)		1709			528			668			695	
Turn Bay Length (ft)	375		175	200		50	200		98	190		130
Base Capacity (vph)	474	936	859	598	769	715	488	713	660	125	580	630
Starvation Cap Reductn	0	0	0	0	57	0	0	0	0	0	0	0
Spillback Cap Reductn	0	0	0	0	0	0	0	0	0	0	0	0
Storage Cap Reductn	0	0	0	0	0	0	0	0	0	0	0	0
Reduced v/c Ratio	0.37	0.58	0.38	0.05	0.82	0.12	0.65	0.42	0.04	0.67	0.43	0.42

Intersection Summary

# 95th percentile volume exceeds capacity, queue may be longer.  
Queue shown is maximum after two cycles.

Queues

2: Shiloh Road & Hembree Ln

2028+P Alternative A\_Mitigations

Timing Plan: Saturday Midday Peak

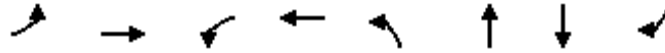

Lane Group	EBL	EBT	WBL	WBT	NBL	NBT	SBT	SBR
Lane Group Flow (vph)	753	950	24	1018	65	26	211	732
v/c Ratio	0.94	0.91	0.25	0.85	0.69	0.25	0.50	0.92
Control Delay	61.6	36.4	56.8	38.6	86.8	36.3	41.2	39.0
Queue Delay	0.0	9.2	0.0	0.0	0.0	0.0	0.0	0.0
Total Delay	61.6	45.5	56.8	38.6	86.8	36.3	41.2	39.0
Queue Length 50th (ft)	~278	615	17	327	46	8	132	355
Queue Length 95th (ft)	#406	#921	45	412	#122	37	210	#477
Internal Link Dist (ft)		222		1709		136	301	
Turn Bay Length (ft)			100					
Base Capacity (vph)	800	1065	96	1353	94	105	421	794
Starvation Cap Reductn	0	102	0	0	0	0	0	0
Spillback Cap Reductn	0	0	0	0	0	0	0	0
Storage Cap Reductn	0	0	0	0	0	0	0	0
Reduced v/c Ratio	0.94	0.99	0.25	0.75	0.69	0.25	0.50	0.92

Intersection Summary

~ Volume exceeds capacity, queue is theoretically infinite.

Queue shown is maximum after two cycles.

# 95th percentile volume exceeds capacity, queue may be longer.

Queue shown is maximum after two cycles.

Queues  
7: Driveway 1/Gridley Drive & Shiloh Road

2028+P Alternative A\_Mitigations  
Timing Plan: Saturday Midday Peak

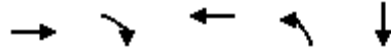

Lane Group	EBT	EBR	WBT	NBL	SBT
Lane Group Flow (vph)	523	120	523	464	36
v/c Ratio	0.79	0.18	0.74	0.82	0.05
Control Delay	25.9	3.8	22.5	27.8	0.1
Queue Delay	0.0	0.0	0.0	0.0	0.0
Total Delay	25.9	3.8	22.5	27.8	0.1
Queue Length 50th (ft)	152	0	148	134	0
Queue Length 95th (ft)	#307	26	248	41	0
Internal Link Dist (ft)	528		2066		635
Turn Bay Length (ft)		150			
Base Capacity (vph)	823	800	878	736	952
Starvation Cap Reductn	0	0	0	0	0
Spillback Cap Reductn	0	0	0	0	0
Storage Cap Reductn	0	0	0	0	0
Reduced v/c Ratio	0.64	0.15	0.60	0.63	0.04

Intersection Summary

# 95th percentile volume exceeds capacity, queue may be longer.  
Queue shown is maximum after two cycles.

Queues  
8: Old Redwood Hwy & Driveway 2

2028+P Alternative A\_Mitigations  
Timing Plan: Saturday Midday Peak

























Lane Group	EBT	WBL	WBT	NBT	NBR	SBL	SBT
Lane Group Flow (vph)	8	68	109	489	70	113	423
v/c Ratio	0.02	0.18	0.18	0.45	0.08	0.23	0.39
Control Delay	0.0	13.1	0.7	8.6	2.2	7.8	7.9
Queue Delay	0.0	0.0	0.0	0.0	0.0	0.0	0.0
Total Delay	0.0	13.1	0.7	8.6	2.2	7.8	7.9
Queue Length 50th (ft)	0	9	0	67	0	13	55
Queue Length 95th (ft)	0	36	0	125	12	35	103
Internal Link Dist (ft)	18		305	440			668
Turn Bay Length (ft)					100	50	
Base Capacity (vph)	761	680	894	1195	1025	551	1194
Starvation Cap Reductn	0	0	0	0	0	0	0
Spillback Cap Reductn	0	0	0	0	0	0	0
Storage Cap Reductn	0	0	0	0	0	0	0
Reduced v/c Ratio	0.01	0.10	0.12	0.41	0.07	0.21	0.35
<b>Intersection Summary</b>							

Lanes, Volumes, Timings  
1: Old Redwood Hwy & Shiloh Road

2028 Opening Year Alter. A Conditions

Timing Plan: A.M. PEAK

												
Lane Group	EBL	EBT	EBR	WBL	WBT	WBR	NBL	NBT	NBR	SBL	SBT	SBR
Lane Configurations												
Traffic Volume (vph)	137	290	135	25	180	28	120	146	39	37	269	208
Future Volume (vph)	137	290	135	25	180	28	120	146	39	37	269	208
Ideal Flow (vphpl)	1900	1900	1900	1900	1900	1900	1900	1900	1900	1900	1900	1900
Storage Length (ft)	375		140	0		50	200		98	130		93
Storage Lanes	1		1	0		1	1		1	1		1
Taper Length (ft)	50			25			60			93		
Lane Util. Factor	1.00	1.00	1.00	1.00	1.00	1.00	1.00	1.00	1.00	1.00	1.00	1.00
Ped Bike Factor												0.98
Frt			0.850			0.850			0.850			0.850
Flt Protected	0.950				0.994		0.950			0.950		
Satd. Flow (prot)	1770	1863	1583	0	1852	1583	1770	1863	1583	1770	1863	1583
Flt Permitted	0.950				0.994		0.950			0.950		
Satd. Flow (perm)	1770	1863	1583	0	1852	1583	1770	1863	1583	1770	1863	1549
Right Turn on Red			Yes			Yes			Yes			Yes
Satd. Flow (RTOR)			106			105			77			132
Link Speed (mph)		40			40			45			40	
Link Distance (ft)		1789			608			748			775	
Travel Time (s)		30.5			10.4			11.3			13.2	
Confl. Bikes (#/hr)												1
Peak Hour Factor	0.81	0.81	0.81	0.89	0.89	0.89	0.93	0.93	0.93	0.85	0.85	0.85
Adj. Flow (vph)	169	358	167	28	202	31	129	157	42	44	316	245
Shared Lane Traffic (%)												
Lane Group Flow (vph)	169	358	167	0	230	31	129	157	42	44	316	245
Enter Blocked Intersection	No	No	No	No	No	No	No	No	No	No	No	No
Lane Alignment	Left	Left	Right	Left	Left	Right	Left	Left	Right	Left	Left	Right
Median Width(ft)		12			12			12			12	
Link Offset(ft)		0			0			0			0	
Crosswalk Width(ft)		16			16			16			16	
Two way Left Turn Lane												
Headway Factor	1.00	1.00	1.00	1.00	1.00	1.00	1.00	1.00	1.00	1.00	1.00	1.00
Turning Speed (mph)	15		9	15		9	15		9	15		9
Number of Detectors	1	2	1	1	2	1	1	2	1	1	2	1
Detector Template	Left	Thru	Right	Left	Thru	Right	Left	Thru	Right	Left	Thru	Right
Leading Detector (ft)	20	100	20	20	100	20	20	100	20	20	100	20
Trailing Detector (ft)	0	0	0	0	0	0	0	0	0	0	0	0
Detector 1 Position(ft)	0	0	0	0	0	0	0	0	0	0	0	0
Detector 1 Size(ft)	20	6	20	20	6	20	20	6	20	20	6	20
Detector 1 Type	Cl+Ex	Cl+Ex	Cl+Ex	Cl+Ex	Cl+Ex	Cl+Ex	Cl+Ex	Cl+Ex	Cl+Ex	Cl+Ex	Cl+Ex	Cl+Ex
Detector 1 Channel												
Detector 1 Extend (s)	0.0	0.0	0.0	0.0	0.0	0.0	0.0	0.0	0.0	0.0	0.0	0.0
Detector 1 Queue (s)	0.0	0.0	0.0	0.0	0.0	0.0	0.0	0.0	0.0	0.0	0.0	0.0
Detector 1 Delay (s)	0.0	0.0	0.0	0.0	0.0	0.0	0.0	0.0	0.0	0.0	0.0	0.0
Detector 2 Position(ft)		94			94			94			94	
Detector 2 Size(ft)		6			6			6			6	
Detector 2 Type		Cl+Ex			Cl+Ex			Cl+Ex			Cl+Ex	
Detector 2 Channel												
Detector 2 Extend (s)		0.0			0.0			0.0			0.0	
Turn Type	Split	NA	Perm	Split	NA	Perm	Prot	NA	Perm	Prot	NA	Perm

Lanes, Volumes, Timings  
1: Old Redwood Hwy & Shiloh Road

2028 Opening Year Alter. A Conditions

Timing Plan: A.M. PEAK

Lane Group	EBL	EBT	EBR	WBL	WBT	WBR	NBL	NBT	NBR	SBL	SBT	SBR
Protected Phases	2	2		6	6		3	8		7	4	
Permitted Phases			2			6			8			4
Detector Phase	2	2	2	6	6	6	3	8	8	7	4	4
Switch Phase												
Minimum Initial (s)	5.0	5.0	5.0	5.0	5.0	5.0	5.0	5.0	5.0	5.0	5.0	5.0
Minimum Split (s)	34.5	34.5	34.5	42.5	42.5	42.5	8.5	46.5	46.5	8.5	39.5	39.5
Total Split (s)	35.0	35.0	35.0	42.5	42.5	42.5	18.0	48.0	48.0	9.5	39.5	39.5
Total Split (%)	25.9%	25.9%	25.9%	31.5%	31.5%	31.5%	13.3%	35.6%	35.6%	7.0%	29.3%	29.3%
Maximum Green (s)	30.5	30.5	30.5	38.0	38.0	38.0	14.5	43.5	43.5	6.0	35.0	35.0
Yellow Time (s)	3.5	3.5	3.5	3.5	3.5	3.5	3.0	3.5	3.5	3.0	3.5	3.5
All-Red Time (s)	1.0	1.0	1.0	1.0	1.0	1.0	0.5	1.0	1.0	0.5	1.0	1.0
Lost Time Adjust (s)	0.0	0.0	0.0		0.0	0.0	0.0	0.0	0.0	0.0	0.0	0.0
Total Lost Time (s)	4.5	4.5	4.5		4.5	4.5	3.5	4.5	4.5	3.5	4.5	4.5
Lead/Lag	Lead	Lead	Lead	Lag	Lag	Lag	Lead	Lag	Lag	Lead	Lag	Lag
Lead-Lag Optimize?	Yes	Yes	Yes	Yes	Yes	Yes	Yes	Yes	Yes	Yes	Yes	Yes
Vehicle Extension (s)	3.0	3.0	3.0	3.0	3.0	3.0	3.0	3.0	3.0	3.0	3.0	3.0
Recall Mode	None	None	None	None	None	None	None	None	None	None	None	None
Walk Time (s)	7.0	7.0	7.0	7.0	7.0	7.0		7.0	7.0		7.0	7.0
Flash Don't Walk (s)	23.0	23.0	23.0	31.0	31.0	31.0		35.0	35.0		28.0	28.0
Pedestrian Calls (#/hr)	0	0	0	0	0	0		0	0		0	0
Act Effct Green (s)	25.1	25.1	25.1		18.3	18.3	12.3	31.9	31.9	6.2	23.0	23.0
Actuated g/C Ratio	0.26	0.26	0.26		0.19	0.19	0.13	0.33	0.33	0.06	0.24	0.24
v/c Ratio	0.37	0.74	0.34		0.66	0.08	0.57	0.26	0.07	0.39	0.71	0.52
Control Delay (s/veh)	35.1	45.7	15.8		48.6	0.4	55.6	27.8	1.5	61.6	45.2	20.4
Queue Delay	0.0	0.0	0.0		0.0	0.0	0.0	0.0	0.0	0.0	0.0	0.0
Total Delay (s/veh)	35.1	45.7	15.8		48.6	0.4	55.6	27.8	1.5	61.6	45.2	20.4
LOS	D	D	B		D	A	E	C	A	E	D	C
Approach Delay (s/veh)		35.9			42.9			35.4			36.3	
Approach LOS		D			D			D			D	

Intersection Summary





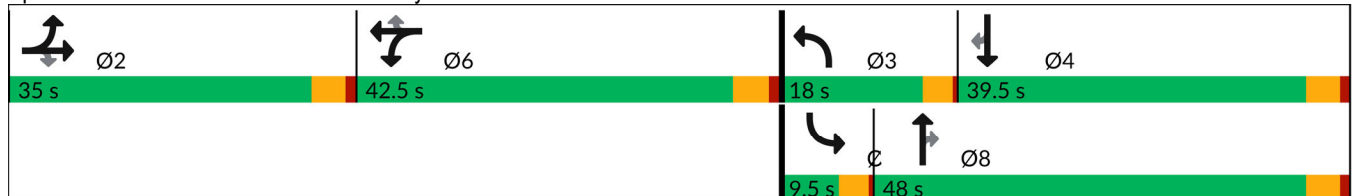























Area Type:	Other
Cycle Length:	135
Actuated Cycle Length:	96.6
Natural Cycle:	135
Control Type:	Actuated-Uncoordinated
Maximum v/c Ratio:	0.74
Intersection Signal Delay (s/veh):	36.9
Intersection LOS:	D
Intersection Capacity Utilization:	61.5%
ICU Level of Service:	B
Analysis Period (min):	15

Splits and Phases: 1: Old Redwood Hwy & Shiloh Road



Lanes, Volumes, Timings  
2: Shiloh Road & Hembree Ln

2028 Opening Year Alter. A Conditions  
Timing Plan: A.M. PEAK

												
Lane Group	EBL	EBT	EBR	WBL	WBT	WBR	NBL	NBT	NBR	SBL	SBT	SBR
Lane Configurations	 			 	 		 			 	 	 
Traffic Volume (vph)	347	511	38	19	466	82	39	7	11	81	9	413
Future Volume (vph)	347	511	38	19	466	82	39	7	11	81	9	413
Ideal Flow (vphpl)	1900	1900	1900	1900	1900	1900	1900	1900	1900	1900	1900	1900
Storage Length (ft)	0		0	100		130	0		0	0		0
Storage Lanes	2		0	1		1	1		0	0		1
Taper Length (ft)	25			50			25			25		
Lane Util. Factor	0.97	1.00	1.00	1.00	0.95	0.95	1.00	1.00	1.00	1.00	1.00	1.00
Frt		0.991			0.977			0.908				0.850
Flt Protected	0.950			0.950			0.950				0.957	
Satd. Flow (prot)	3433	1846	0	1770	3458	0	1770	1691	0	0	1783	1583
Flt Permitted	0.950			0.950			0.950				0.957	
Satd. Flow (perm)	3433	1846	0	1770	3458	0	1770	1691	0	0	1783	1583
Right Turn on Red			Yes			Yes			Yes			Yes
Satd. Flow (RTOR)		6			30			11				305
Link Speed (mph)		40			40			30				35
Link Distance (ft)		302			1789			216				381
Travel Time (s)		5.1			30.5			4.9				7.4
Peak Hour Factor	0.88	0.88	1.00	1.00	0.97	0.97	1.00	1.00	1.00	0.94	1.00	0.94
Adj. Flow (vph)	394	581	38	19	480	85	39	7	11	86	9	439
Shared Lane Traffic (%)												
Lane Group Flow (vph)	394	619	0	19	565	0	39	18	0	0	95	439
Enter Blocked Intersection	No	No	No	No	No	No	No	No	No	No	No	No
Lane Alignment	Left	Left	Right	Left	Left	Right	Left	Left	Right	Left	Left	Right
Median Width(ft)		24			24			12				12
Link Offset(ft)		0			0			0				0
Crosswalk Width(ft)		16			16			16				16
Two way Left Turn Lane												
Headway Factor	1.00	1.00	1.00	1.00	1.00	1.00	1.00	1.00	1.00	1.00	1.00	1.00
Turning Speed (mph)	15		60	60		9	60		60	15		9
Number of Detectors	1	2		1	2		1	2		1	2	1
Detector Template	Left	Thru		Left	Thru		Left	Thru		Left	Thru	Right
Leading Detector (ft)	20	100		20	100		20	100		20	100	20
Trailing Detector (ft)	0	0		0	0		0	0		0	0	0
Detector 1 Position(ft)	0	0		0	0		0	0		0	0	0
Detector 1 Size(ft)	20	6		20	6		20	6		20	6	20
Detector 1 Type	Cl+Ex	Cl+Ex		Cl+Ex	Cl+Ex		Cl+Ex	Cl+Ex		Cl+Ex	Cl+Ex	Cl+Ex
Detector 1 Channel												
Detector 1 Extend (s)	0.0	0.0		0.0	0.0		0.0	0.0		0.0	0.0	0.0
Detector 1 Queue (s)	0.0	0.0		0.0	0.0		0.0	0.0		0.0	0.0	0.0
Detector 1 Delay (s)	0.0	0.0		0.0	0.0		0.0	0.0		0.0	0.0	0.0
Detector 2 Position(ft)		94			94			94				94
Detector 2 Size(ft)		6			6			6				6
Detector 2 Type		Cl+Ex			Cl+Ex			Cl+Ex				Cl+Ex
Detector 2 Channel												
Detector 2 Extend (s)		0.0			0.0			0.0				0.0
Turn Type	Prot	NA		Prot	NA		Split	NA		Split	NA	pt+ov
Protected Phases	5	2		1	6		8	8		4	4	4
Permitted Phases												

Lanes, Volumes, Timings  
2: Shiloh Road & Hembree Ln

2028 Opening Year Alter. A Conditions  
Timing Plan: A.M. PEAK

Lane Group	EBL	EBT	EBR	WBL	WBT	WBR	NBL	NBT	NBR	SBL	SBT	SBR
Detector Phase	5	2		1	6		8	8		4	4	4 5
Switch Phase												
Minimum Initial (s)	3.0	5.0		5.0	5.0		5.0	5.0		5.0	5.0	
Minimum Split (s)	7.5	9.5		9.5	43.5		9.5	9.5		9.5	9.5	
Total Split (s)	21.0	57.0		9.5	45.5		9.5	9.5		14.0	14.0	
Total Split (%)	23.3%	63.3%		10.6%	50.6%		10.6%	10.6%		15.6%	15.6%	
Maximum Green (s)	17.0	53.0		5.5	41.5		5.5	5.5		10.0	10.0	
Yellow Time (s)	3.0	3.0		3.0	3.0		3.0	3.0		3.0	3.0	
All-Red Time (s)	1.0	1.0		1.0	1.0		1.0	1.0		1.0	1.0	
Lost Time Adjust (s)	0.0	0.0		0.0	0.0		0.0	0.0		0.0	0.0	
Total Lost Time (s)	4.0	4.0		4.0	4.0		4.0	4.0		4.0	4.0	
Lead/Lag	Lead	Lag		Lead	Lag							
Lead-Lag Optimize?	Yes	Yes		Yes	Yes							
Vehicle Extension (s)	3.0	3.0		3.0	3.0		3.0	3.0		3.0	3.0	
Recall Mode	None	None		None	None		None	None		None	None	
Walk Time (s)					7.0							
Flash Don't Walk (s)					32.0							
Pedestrian Calls (#/hr)					1							
Act Effct Green (s)	12.6	33.2		6.2	17.4		6.2	6.2		8.9	23.9	
Actuated g/C Ratio	0.22	0.58		0.11	0.31		0.11	0.11		0.16	0.42	
v/c Ratio	0.52	0.57		0.10	0.53		0.20	0.09		0.34	0.52	
Control Delay (s/veh)	25.4	11.3		34.1	17.7		34.8	24.3		31.5	6.7	
Queue Delay	0.0	0.0		0.0	0.0		0.0	0.0		0.0	0.0	
Total Delay (s/veh)	25.4	11.3		34.1	17.7		34.8	24.3		31.5	6.7	
LOS	C	B		C	B		C	C		C	A	
Approach Delay (s/veh)		16.8			18.2			31.5			11.1	
Approach LOS		B			B			C			B	

Intersection Summary	
Area Type:	Other
Cycle Length:	90
Actuated Cycle Length:	57
Natural Cycle:	80
Control Type:	Actuated-Uncoordinated
Maximum v/c Ratio:	0.57
Intersection Signal Delay (s/veh):	16.2
Intersection LOS:	B
Intersection Capacity Utilization:	55.2%
ICU Level of Service:	B
Analysis Period (min):	15

Splits and Phases: 2: Shiloh Road & Hembree Ln

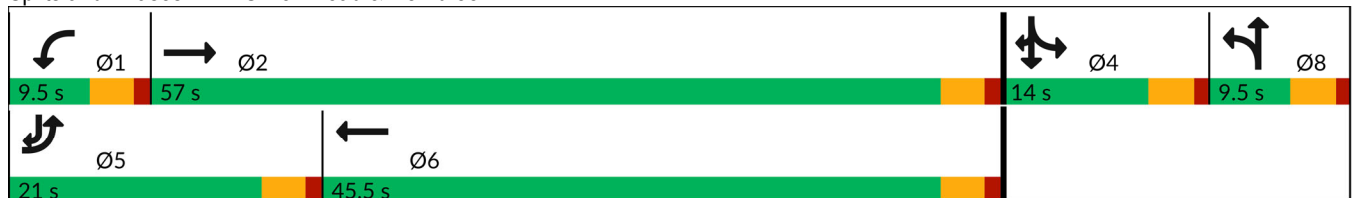



Lanes, Volumes, Timings  
3: US 101 NB Off-Ramp & Shiloh Road

2028 Opening Year Alter. A Conditions

Timing Plan: A.M. PEAK

	→	↘	↙	←	↖	↗
Lane Group	EBT	EBR	WBL	WBT	NBL	NBR
Lane Configurations	↑↑			↑	↘	↗
Traffic Volume (vph)	360	0	0	711	492	552
Future Volume (vph)	360	0	0	711	492	552
Ideal Flow (vphpl)	1900	1900	1900	1900	1900	1900
Storage Length (ft)		0	0		0	265
Storage Lanes		0	0		1	2
Taper Length (ft)			25		25	
Lane Util. Factor	0.95	1.00	1.00	1.00	1.00	0.88
Frt						0.850
Flt Protected					0.950	
Satd. Flow (prot)	3539	0	0	1863	1770	2787
Flt Permitted					0.950	
Satd. Flow (perm)	3539	0	0	1863	1770	2787
Right Turn on Red		Yes				Yes
Satd. Flow (RTOR)						628
Link Speed (mph)	40			40	30	
Link Distance (ft)	186			371	769	
Travel Time (s)	3.2			6.3	17.5	
Peak Hour Factor	0.91	0.91	0.90	0.90	0.76	0.76
Adj. Flow (vph)	396	0	0	790	647	726
Shared Lane Traffic (%)						
Lane Group Flow (vph)	396	0	0	790	647	726
Enter Blocked Intersection	No	No	No	No	No	No
Lane Alignment	Left	Right	Left	Left	Left	Right
Median Width(ft)	0			0	12	
Link Offset(ft)	0			0	0	
Crosswalk Width(ft)	16			16	16	
Two way Left Turn Lane						
Headway Factor	1.00	1.00	1.00	1.00	1.00	1.00
Turning Speed (mph)		9	15		15	9
Number of Detectors	2			2	1	1
Detector Template	Thru			Thru	Left	Right
Leading Detector (ft)	100			100	20	20
Trailing Detector (ft)	0			0	0	0
Detector 1 Position(ft)	0			0	0	0
Detector 1 Size(ft)	6			6	20	20
Detector 1 Type	Cl+Ex			Cl+Ex	Cl+Ex	Cl+Ex
Detector 1 Channel						
Detector 1 Extend (s)	0.0			0.0	0.0	0.0
Detector 1 Queue (s)	0.0			0.0	0.0	0.0
Detector 1 Delay (s)	0.0			0.0	0.0	0.0
Detector 2 Position(ft)	94			94		
Detector 2 Size(ft)	6			6		
Detector 2 Type	Cl+Ex			Cl+Ex		
Detector 2 Channel						
Detector 2 Extend (s)	0.0			0.0		
Turn Type	NA			NA	Prot	Perm
Protected Phases	2			6	8	
Permitted Phases						8

Lanes, Volumes, Timings  
 3: US 101 NB Off-Ramp & Shiloh Road

2028 Opening Year Alter. A Conditions  
 Timing Plan: A.M. PEAK



Lane Group	EBT	EBR	WBL	WBT	NBL	NBR
Detector Phase	2			6	8	8
Switch Phase						
Minimum Initial (s)	5.0			5.0	5.0	5.0
Minimum Split (s)	9.0			9.0	9.0	9.0
Total Split (s)	37.0			37.0	35.0	35.0
Total Split (%)	51.4%			51.4%	48.6%	48.6%
Maximum Green (s)	33.0			33.0	31.0	31.0
Yellow Time (s)	3.0			3.0	3.0	3.0
All-Red Time (s)	1.0			1.0	1.0	1.0
Lost Time Adjust (s)	0.0			0.0	0.0	0.0
Total Lost Time (s)	4.0			4.0	4.0	4.0
Lead/Lag						
Lead-Lag Optimize?						
Vehicle Extension (s)	3.0			3.0	3.0	3.0
Recall Mode	None			None	None	None
Act Effect Green (s)	31.2			31.2	28.3	28.3
Actuated g/C Ratio	0.46			0.46	0.42	0.42
v/c Ratio	0.24			0.92	0.87	0.47
Control Delay (s/veh)	12.0			36.2	33.6	3.4
Queue Delay	0.0			0.0	0.0	0.0
Total Delay (s/veh)	12.0			36.2	33.6	3.4
LOS	B			D	C	A
Approach Delay (s/veh)	12.0			36.2	17.6	
Approach LOS	B			D	B	

Intersection Summary

Area Type: Other  
 Cycle Length: 72  
 Actuated Cycle Length: 67.6  
 Natural Cycle: 65  
 Control Type: Actuated-Uncoordinated  
 Maximum v/c Ratio: 0.92  
 Intersection Signal Delay (s/veh): 22.5  
 Intersection LOS: C  
 Intersection Capacity Utilization 102.8%  
 ICU Level of Service G  
 Analysis Period (min) 15

Splits and Phases: 3: US 101 NB Off-Ramp & Shiloh Road

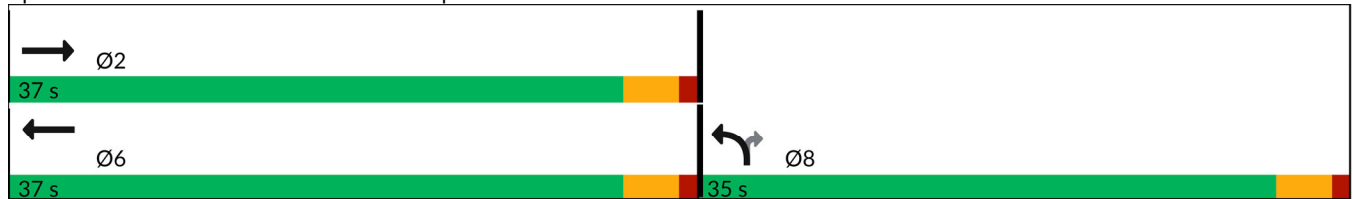

Lanes, Volumes, Timings  
4: Shiloh Road & US 101 SB Off-Ramp

2028 Opening Year Alter. A Conditions

Timing Plan: A.M. PEAK

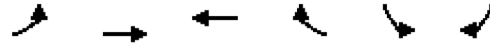

Lane Group	EBL	EBT	WBT	WBR	SBL	SBR
Lane Configurations		↑	↑		↘	↗
Traffic Volume (vph)	0	281	686	0	162	174
Future Volume (vph)	0	281	686	0	162	174
Ideal Flow (vphpl)	1900	1900	1900	1900	1900	1900
Storage Length (ft)	0			0	0	275
Storage Lanes	0			0	1	1
Taper Length (ft)	25				25	
Lane Util. Factor	1.00	1.00	1.00	1.00	1.00	1.00
Frt						0.850
Flt Protected					0.950	
Satd. Flow (prot)	0	1863	1863	0	1770	1583
Flt Permitted					0.950	
Satd. Flow (perm)	0	1863	1863	0	1770	1583
Right Turn on Red				Yes		Yes
Satd. Flow (RTOR)						189
Link Speed (mph)		40	40		30	
Link Distance (ft)		225	306		486	
Travel Time (s)		3.8	5.2		11.0	
Peak Hour Factor	0.93	0.93	0.91	0.91	0.92	0.92
Adj. Flow (vph)	0	302	754	0	176	189
Shared Lane Traffic (%)						
Lane Group Flow (vph)	0	302	754	0	176	189
Enter Blocked Intersection	No	No	No	No	No	No
Lane Alignment	Left	Left	Left	Right	Left	Right
Median Width(ft)		4	0		12	
Link Offset(ft)		0	0		0	
Crosswalk Width(ft)		16	16		16	
Two way Left Turn Lane						
Headway Factor	1.00	1.00	1.00	1.00	1.00	1.00
Turning Speed (mph)	15			9	15	9
Number of Detectors		2	2		1	1
Detector Template		Thru	Thru		Left	Right
Leading Detector (ft)		100	100		20	20
Trailing Detector (ft)		0	0		0	0
Detector 1 Position(ft)		0	0		0	0
Detector 1 Size(ft)		6	6		20	20
Detector 1 Type		Cl+Ex	Cl+Ex		Cl+Ex	Cl+Ex
Detector 1 Channel						
Detector 1 Extend (s)		0.0	0.0		0.0	0.0
Detector 1 Queue (s)		0.0	0.0		0.0	0.0
Detector 1 Delay (s)		0.0	0.0		0.0	0.0
Detector 2 Position(ft)		94	94			
Detector 2 Size(ft)		6	6			
Detector 2 Type		Cl+Ex	Cl+Ex			
Detector 2 Channel						
Detector 2 Extend (s)		0.0	0.0			
Turn Type		NA	NA		Perm	Perm
Protected Phases		2	6			
Permitted Phases					4	4

Lanes, Volumes, Timings  
4: Shiloh Road & US 101 SB Off-Ramp

2028 Opening Year Alter. A Conditions  
Timing Plan: A.M. PEAK

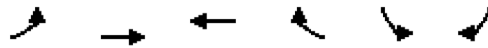

Lane Group	EBL	EBT	WBT	WBR	SBL	SBR
Detector Phase		2	6		4	4
Switch Phase						
Minimum Initial (s)		5.0	5.0		5.0	5.0
Minimum Split (s)		9.0	38.0		9.0	9.0
Total Split (s)		69.0	69.0		21.0	21.0
Total Split (%)		76.7%	76.7%		23.3%	23.3%
Maximum Green (s)		65.0	65.0		17.0	17.0
Yellow Time (s)		3.0	3.0		3.0	3.0
All-Red Time (s)		1.0	1.0		1.0	1.0
Lost Time Adjust (s)		0.0	0.0		0.0	0.0
Total Lost Time (s)		4.0	4.0		4.0	4.0
Lead/Lag						
Lead-Lag Optimize?						
Vehicle Extension (s)		3.0	3.0		3.0	3.0
Recall Mode		None	None		None	None
Walk Time (s)			7.0			
Flash Don't Walk (s)			27.0			
Pedestrian Calls (#/hr)			0			
Act Effct Green (s)		24.4	24.4		10.0	10.0
Actuated g/C Ratio		0.57	0.57		0.23	0.23
v/c Ratio		0.29	0.71		0.43	0.37
Control Delay (s/veh)		5.5	11.1		20.1	6.0
Queue Delay		0.0	0.0		0.0	0.0
Total Delay (s/veh)		5.5	11.1		20.1	6.0
LOS		A	B		C	A
Approach Delay (s/veh)		5.5	11.1		12.8	
Approach LOS		A	B		B	

Intersection Summary

Area Type:	Other
Cycle Length:	90
Actuated Cycle Length:	43
Natural Cycle:	50
Control Type:	Actuated-Uncoordinated
Maximum v/c Ratio:	0.71
Intersection Signal Delay (s/veh):	10.4
Intersection LOS:	B
Intersection Capacity Utilization:	68.9%
ICU Level of Service:	C
Analysis Period (min):	15

Splits and Phases: 4: Shiloh Road & US 101 SB Off-Ramp

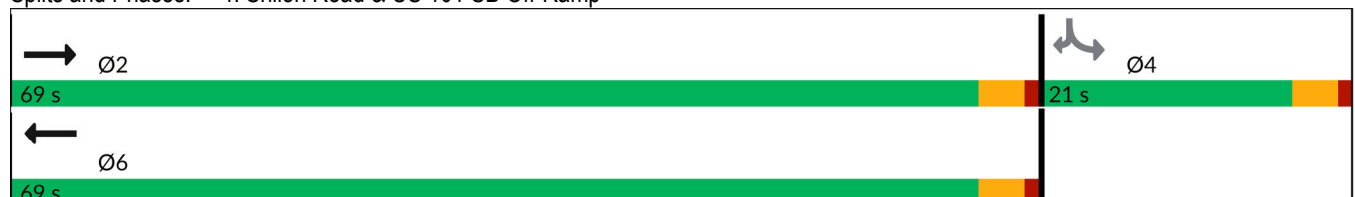

Lanes, Volumes, Timings  
5: Caletti Ave & Shiloh Road

2028 Opening Year Alter. A Conditions  
Timing Plan: A.M. PEAK

	→	↘	↙	←	↖	↗
Lane Group	EBT	EBR	WBL	WBT	NBL	NBR
Lane Configurations	↑↑		↘	↑	↘	↗
Traffic Volume (vph)	604	25	202	633	8	138
Future Volume (vph)	604	25	202	633	8	138
Ideal Flow (vphpl)	1900	1900	1900	1900	1900	1900
Storage Length (ft)		0	68		0	0
Storage Lanes		0	1		1	1
Taper Length (ft)			50		25	
Lane Util. Factor	0.95	0.95	1.00	1.00	1.00	1.00
Frt	0.994					0.850
Flt Protected			0.950		0.950	
Satd. Flow (prot)	3518	0	1770	1863	1770	1583
Flt Permitted			0.950		0.950	
Satd. Flow (perm)	3518	0	1770	1863	1770	1583
Link Speed (mph)	40			40	30	
Link Distance (ft)	1081			184	459	
Travel Time (s)	18.4			3.1	10.4	
Peak Hour Factor	0.96	0.96	0.87	0.87	0.84	0.84
Adj. Flow (vph)	629	26	232	728	10	164
Shared Lane Traffic (%)						
Lane Group Flow (vph)	655	0	232	728	10	164
Enter Blocked Intersection	No	No	No	No	No	No
Lane Alignment	Left	Right	Left	Left	Left	Right
Median Width(ft)	12			12	12	
Link Offset(ft)	0			0	0	
Crosswalk Width(ft)	16			16	16	
Two way Left Turn Lane						
Headway Factor	1.00	1.00	1.00	1.00	1.00	1.00
Turning Speed (mph)		9	15		15	9
Sign Control	Free			Free	Stop	
<b>Intersection Summary</b>						
Area Type:	Other					
Control Type:	Unsignalized					
Intersection Capacity Utilization	43.3%			ICU Level of Service A		
Analysis Period (min)	15					

Lanes, Volumes, Timings  
6: Conde Lane & Shiloh Road

2028 Opening Year Alter. A Conditions

Timing Plan: A.M. PEAK

Lane Group	EBL	EBT	EBR	WBL	WBT	WBR	NBL	NBT	NBR	SBL	SBT	SBR
Lane Configurations												
Traffic Volume (vph)	28	382	6	10	410	232	5	0	14	233	1	40
Future Volume (vph)	28	382	6	10	410	232	5	0	14	233	1	40
Ideal Flow (vphpl)	1900	1900	1900	1900	1900	1900	1900	1900	1900	1900	1900	1900
Storage Length (ft)	90		0	127		0	0		0	0		40
Storage Lanes	1		0	1		0	0		0	0		1
Taper Length (ft)	70			40			25			25		
Lane Util. Factor	1.00	0.95	0.95	1.00	0.95	0.95	1.00	1.00	1.00	1.00	1.00	1.00
Frt		0.998			0.946			0.901				0.850
Flt Protected	0.950			0.950				0.987			0.953	
Satd. Flow (prot)	1770	3532	0	1770	3348	0	0	1657	0	0	1775	1583
Flt Permitted	0.950			0.950				0.987			0.953	
Satd. Flow (perm)	1770	3532	0	1770	3348	0	0	1657	0	0	1775	1583
Right Turn on Red			Yes			Yes			Yes			No
Satd. Flow (RTOR)		2			115			89				
Link Speed (mph)		40			40			30				35
Link Distance (ft)		815			1081			418				522
Travel Time (s)		13.9			18.4			9.5				10.2
Peak Hour Factor	0.95	0.95	0.95	0.85	0.85	0.85	0.57	0.57	0.57	0.86	0.86	0.86
Adj. Flow (vph)	29	402	6	12	482	273	9	0	25	271	1	47
Shared Lane Traffic (%)												
Lane Group Flow (vph)	29	408	0	12	755	0	0	34	0	0	272	47
Enter Blocked Intersection	No	No	No	No	No	No	No	No	No	No	No	No
Lane Alignment	Left	Left	Right	Left	Left	Right	Left	Left	Right	Left	Left	Right
Median Width(ft)		12			12			0				0
Link Offset(ft)		0			0			0				0
Crosswalk Width(ft)		16			16			16				16
Two way Left Turn Lane												
Headway Factor	1.00	1.00	1.00	1.00	1.00	1.00	1.00	1.00	1.00	1.00	1.00	1.00
Turning Speed (mph)	15		9	15		9	15		9	15		9
Number of Detectors	1	2		1	2		1	2		1	1	1
Detector Template	Left	Thru		Left	Thru		Left	Thru		Left	Thru	Right
Leading Detector (ft)	20	100		20	100		20	100		20	30	20
Trailing Detector (ft)	0	0		0	0		0	0		0	0	0
Detector 1 Position(ft)	0	0		0	0		0	0		0	0	0
Detector 1 Size(ft)	20	6		20	6		20	6		20	30	20
Detector 1 Type	Cl+Ex	Cl+Ex		Cl+Ex	Cl+Ex		Cl+Ex	Cl+Ex		Cl+Ex	Cl+Ex	Cl+Ex
Detector 1 Channel												
Detector 1 Extend (s)	0.0	0.0		0.0	0.0		0.0	0.0		0.0	0.0	0.0
Detector 1 Queue (s)	0.0	0.0		0.0	0.0		0.0	0.0		0.0	0.0	0.0
Detector 1 Delay (s)	0.0	0.0		0.0	0.0		0.0	0.0		0.0	0.0	0.0
Detector 2 Position(ft)		94			94			94				
Detector 2 Size(ft)		6			6			6				
Detector 2 Type		Cl+Ex			Cl+Ex			Cl+Ex				
Detector 2 Channel												
Detector 2 Extend (s)		0.0			0.0			0.0				
Turn Type	Prot	NA		Prot	NA		Split	NA		Split	NA	custom
Protected Phases	5	2		1	6		7	7		4	4	
Permitted Phases												6

Lanes, Volumes, Timings  
6: Conde Lane & Shiloh Road

2028 Opening Year Alter. A Conditions

Timing Plan: A.M. PEAK

Lane Group	EBL	EBT	EBR	WBL	WBT	WBR	NBL	NBT	NBR	SBL	SBT	SBR
Detector Phase	5	2		1	6		7	7		4	4	6
Switch Phase												
Minimum Initial (s)	8.0	8.0		8.0	8.0		10.0	10.0		11.0	11.0	8.0
Minimum Split (s)	12.0	46.0		12.0	12.0		37.0	37.0		15.0	15.0	12.0
Total Split (s)	13.0	46.0		12.0	45.0		37.0	37.0		15.0	15.0	45.0
Total Split (%)	11.8%	41.8%		10.9%	40.9%		33.6%	33.6%		13.6%	13.6%	40.9%
Maximum Green (s)	9.0	42.0		8.0	41.0		33.0	33.0		11.0	11.0	41.0
Yellow Time (s)	3.0	3.0		3.0	3.0		3.0	3.0		3.0	3.0	3.0
All-Red Time (s)	1.0	1.0		1.0	1.0		1.0	1.0		1.0	1.0	1.0
Lost Time Adjust (s)	0.0	0.0		0.0	0.0		0.0	0.0		0.0	0.0	0.0
Total Lost Time (s)	4.0	4.0		4.0	4.0		4.0	4.0		4.0	4.0	4.0
Lead/Lag	Lead	Lag		Lead	Lag							Lag
Lead-Lag Optimize?	Yes	Yes		Yes	Yes							Yes
Vehicle Extension (s)	3.0	3.0		3.0	3.0		3.0	3.0		3.0	3.0	3.0
Recall Mode	None	None		None	None		None	None		None	None	None
Walk Time (s)		7.0					7.0	7.0				
Flash Don't Walk (s)		35.0					26.0	26.0				
Pedestrian Calls (#/hr)		0					0	0				
Act Effct Green (s)	9.4	19.7		9.3	18.0			11.6			12.8	18.0
Actuated g/C Ratio	0.20	0.42		0.20	0.38			0.25			0.27	0.38
v/c Ratio	0.08	0.28		0.03	0.56			0.07			0.57	0.08
Control Delay (s/veh)	25.6	10.6		25.9	13.1			0.3			30.3	13.2
Queue Delay	0.0	0.0		0.0	0.0			0.0			0.0	0.0
Total Delay (s/veh)	25.6	10.6		25.9	13.1			0.3			30.3	13.2
LOS	C	B		C	B			A			C	B
Approach Delay (s/veh)		11.6			13.3			0.3			27.8	
Approach LOS		B			B			A			C	

Intersection Summary



















Area Type:	Other
Cycle Length:	110
Actuated Cycle Length:	47.2
Natural Cycle:	110
Control Type:	Actuated-Uncoordinated
Maximum v/c Ratio:	0.57
Intersection Signal Delay (s/veh):	15.5
Intersection LOS:	B
Intersection Capacity Utilization:	49.6%
ICU Level of Service:	A
Analysis Period (min):	15

Splits and Phases: 6: Conde Lane & Shiloh Road



Lanes, Volumes, Timings  
 7: Driveway 1/Gridley Drive & Shiloh Road

2028 Opening Year Alter. A Conditions  
 Timing Plan: A.M. PEAK

												
Lane Group	EBL	EBT	EBR	WBL	WBT	WBR	NBL	NBT	NBR	SBL	SBT	SBR
Lane Configurations												
Traffic Volume (vph)	9	306	47	0	167	0	33	0	0	1	0	18
Future Volume (vph)	9	306	47	0	167	0	33	0	0	1	0	18
Ideal Flow (vphp)	1900	1900	1900	1900	1900	1900	1900	1900	1900	1900	1900	1900
Storage Length (ft)	0		150	0		0	0		0	0		0
Storage Lanes	0		1	0		0	1		0	0		0
Taper Length (ft)	25			25			25			25		
Lane Util. Factor	1.00	1.00	1.00	1.00	1.00	1.00	1.00	1.00	1.00	1.00	1.00	1.00
Ped Bike Factor												
Frt			0.850									0.870
Flt Protected		0.999					0.950					0.998
Satd. Flow (prot)	0	1861	1583	0	1863	0	1770	1863	0	0	1617	0
Flt Permitted		0.999					0.950					0.998
Satd. Flow (perm)	0	1861	1583	0	1863	0	1770	1863	0	0	1617	0
Link Speed (mph)		40			40			30			30	
Link Distance (ft)		608			2146			248			715	
Travel Time (s)		10.4			36.6			5.6			16.3	
Confl. Bikes (#/hr)			1									
Peak Hour Factor	0.91	0.91	0.91	0.85	0.85	0.85	1.00	1.00	1.00	0.71	0.71	0.71
Adj. Flow (vph)	10	336	52	0	196	0	33	0	0	1	0	25
Shared Lane Traffic (%)												
Lane Group Flow (vph)	0	346	52	0	196	0	33	0	0	0	26	0
Enter Blocked Intersection	No	No	No	No	No	No	No	No	No	No	No	No
Lane Alignment	Left	Left	Right	Left	Left	Right	Left	Left	Right	Left	Left	Right
Median Width(ft)		0			0			12			12	
Link Offset(ft)		0			0			0			0	
Crosswalk Width(ft)		16			16			16			16	
Two way Left Turn Lane												
Headway Factor	1.00	1.00	1.00	1.00	1.00	1.00	1.00	1.00	1.00	1.00	1.00	1.00
Turning Speed (mph)	15		9	15		9	15		9	15		9
Sign Control		Free			Free			Stop			Stop	





















Intersection Summary	
Area Type:	Other
Control Type:	Unsignalized
Intersection Capacity Utilization	38.5%
ICU Level of Service	A
Analysis Period (min)	15



Lanes, Volumes, Timings  
8: Old Redwood Hwy & Driveway 2

2028 Opening Year Alter. A Conditions

Timing Plan: A.M. PEAK

												
Lane Group	EBL	EBT	EBR	WBL	WBT	WBR	NBL	NBT	NBR	SBL	SBT	SBR
Lane Configurations												
Traffic Volume (vph)	1	0	0	19	0	31	0	247	28	45	360	0
Future Volume (vph)	1	0	0	19	0	31	0	247	28	45	360	0
Ideal Flow (vphp)	1900	1900	1900	1900	1900	1900	1900	1900	1900	1900	1900	1900
Storage Length (ft)	0		0	0		0	0		100	50		0
Storage Lanes	0		0	1		0	0		1	1		0
Taper Length (ft)	25			25			25			25		
Lane Util. Factor	1.00	1.00	1.00	1.00	1.00	1.00	1.00	1.00	1.00	1.00	1.00	1.00
Ped Bike Factor												
Frt					0.850				0.850			
Flt Protected		0.950		0.950						0.950		
Satd. Flow (prot)	0	1770	0	1770	1583	0	0	1863	1583	1770	1863	0
Flt Permitted		0.950		0.950						0.950		
Satd. Flow (perm)	0	1770	0	1770	1583	0	0	1863	1583	1770	1863	0
Link Speed (mph)		30			30			45			45	
Link Distance (ft)		98			385			520			748	
Travel Time (s)		2.2			8.8			7.9			11.3	
Confl. Peds. (#/hr)									1	1		
Confl. Bikes (#/hr)									1			2
Peak Hour Factor	0.25	0.25	0.25	1.00	1.00	1.00	0.99	0.99	0.99	0.90	0.90	0.90
Adj. Flow (vph)	4	0	0	19	0	31	0	249	28	50	400	0
Shared Lane Traffic (%)												
Lane Group Flow (vph)	0	4	0	19	31	0	0	249	28	50	400	0
Enter Blocked Intersection	No	No	No	No	No	No	No	No	No	No	No	No
Lane Alignment	Left	Left	Right	Left	Left	Right	Left	Left	Right	Left	Left	Right
Median Width(ft)		12			12			12			12	
Link Offset(ft)		0			0			0			0	
Crosswalk Width(ft)		16			16			16			16	
Two way Left Turn Lane												
Headway Factor	1.00	1.00	1.00	1.00	1.00	1.00	1.00	1.00	1.00	1.00	1.00	1.00
Turning Speed (mph)	15		9	15		9	15		9	15		9
Sign Control		Stop			Stop			Free			Free	

Intersection Summary

Area Type:	Other
Control Type:	Unsignalized
Intersection Capacity Utilization	45.3%
Analysis Period (min)	15
	ICU Level of Service A

Lanes, Volumes, Timings  
9: Driveway 2 & Shiloh Road

2028 Opening Year Alter. A Conditions

Timing Plan: A.M. PEAK

	→	↘	↙	←	↖	↗
Lane Group	EBT	EBR	WBL	WBT	NBL	NBR
Lane Configurations	↑	↗		↖	↘	↗
Traffic Volume (vph)	159	145	14	59	101	10
Future Volume (vph)	159	145	14	59	101	10
Ideal Flow (vphpl)	1900	1900	1900	1900	1900	1900
Storage Length (ft)		200	0		0	0
Storage Lanes		1	0		1	1
Taper Length (ft)			25		25	
Lane Util. Factor	1.00	1.00	1.00	1.00	1.00	1.00
Frt		0.850				0.850
Flt Protected				0.991	0.950	
Satd. Flow (prot)	1863	1583	0	1846	1770	1583
Flt Permitted				0.991	0.950	
Satd. Flow (perm)	1863	1583	0	1846	1770	1583
Link Speed (mph)	40			40	30	
Link Distance (ft)	2146			134	402	
Travel Time (s)	36.6			2.3	9.1	
Peak Hour Factor	0.85	0.85	0.81	0.81	1.00	1.00
Adj. Flow (vph)	187	171	17	73	101	10
Shared Lane Traffic (%)						
Lane Group Flow (vph)	187	171	0	90	101	10
Enter Blocked Intersection	No	No	No	No	No	No
Lane Alignment	Left	Right	Left	Left	Left	Right
Median Width(ft)	0			0	12	
Link Offset(ft)	0			0	0	
Crosswalk Width(ft)	16			16	16	
Two way Left Turn Lane						
Headway Factor	1.00	1.00	1.00	1.00	1.00	1.00
Turning Speed (mph)		9	15		15	9
Sign Control	Free			Free	Stop	
<b>Intersection Summary</b>						
Area Type:	Other					
Control Type:	Unsignalized					
Intersection Capacity Utilization	27.4%			ICU Level of Service A		
Analysis Period (min)	15					

Lanes, Volumes, Timings

2028 Opening Year Alter. A Conditions

10: US 101 NB Off Ramp/Lakewood Drive & Old Redwood Highway

Timing Plan: A.M. PEAK



Lane Group	EBL	EBT	EBR	WBL	WBT	WBR	NBL	NBT	NBR	SBL	SBT	SBR
Lane Configurations												
Traffic Volume (vph)	173	198	0	0	520	170	258	252	90	134	0	608
Future Volume (vph)	173	198	0	0	520	170	258	252	90	134	0	608
Ideal Flow (vphpl)	1900	1900	1900	1900	1900	1900	1900	1900	1900	1900	1900	1900
Storage Length (ft)	155		0	0		0	270		150	120		0
Storage Lanes	1		0	0		0	1		1	1		1
Taper Length (ft)	50			25			165			75		
Lane Util. Factor	0.97	1.00	1.00	1.00	0.95	0.95	0.91	0.91	0.95	0.97	1.00	1.00
Ped Bike Factor	1.00				1.00			1.00		1.00		
Flt					0.963			0.966				0.850
Flt Protected	0.950						0.950	0.993		0.950		
Satd. Flow (prot)	3433	1863	0	0	3397	0	1610	3242	0	3433	0	1583
Flt Permitted	0.950						0.950	0.993		0.950		
Satd. Flow (perm)	3431	1863	0	0	3397	0	1610	3242	0	3427	0	1583
Right Turn on Red			Yes			Yes			Yes			Yes
Satd. Flow (RTOR)					50			41				277
Link Speed (mph)		35			35			30				30
Link Distance (ft)		226			617			716				478
Travel Time (s)		4.4			12.0			16.3				10.9
Confl. Peds. (#/hr)	1		1	1		1			2	2		
Confl. Bikes (#/hr)			1			1						
Peak Hour Factor	0.85	0.85	0.85	0.83	0.83	0.83	0.90	0.90	0.90	0.89	0.89	0.89
Adj. Flow (vph)	204	233	0	0	627	205	287	280	100	151	0	683
Shared Lane Traffic (%)							23%					
Lane Group Flow (vph)	204	233	0	0	832	0	221	446	0	151	0	683
Enter Blocked Intersection	No	No	No	No	No	No	No	No	No	No	No	No
Lane Alignment	Left	Left	Right	Left	Left	Right	Left	Left	Right	Left	Left	Right
Median Width(ft)		24			24			24				24
Link Offset(ft)		0			0			0				0
Crosswalk Width(ft)		16			16			16				16
Two way Left Turn Lane												
Headway Factor	1.00	1.00	1.00	1.00	1.00	1.00	1.00	1.00	1.00	1.00	1.00	1.00
Turning Speed (mph)	15		9	15		9	15		9	15		9
Number of Detectors	1	2			2		1	2		1		1
Detector Template	Left	Thru			Thru		Left	Thru		Left		Right
Leading Detector (ft)	20	100			100		20	100		20		20
Trailing Detector (ft)	0	0			0		0	0		0		0
Detector 1 Position(ft)	0	0			0		0	0		0		0
Detector 1 Size(ft)	20	6			6		20	6		20		20
Detector 1 Type	Cl+Ex	Cl+Ex			Cl+Ex		Cl+Ex	Cl+Ex		Cl+Ex		Cl+Ex
Detector 1 Channel												
Detector 1 Extend (s)	0.0	0.0			0.0		0.0	0.0		0.0		0.0
Detector 1 Queue (s)	0.0	0.0			0.0		0.0	0.0		0.0		0.0
Detector 1 Delay (s)	0.0	0.0			0.0		0.0	0.0		0.0		0.0
Detector 2 Position(ft)		94			94			94				
Detector 2 Size(ft)		6			6			6				
Detector 2 Type		Cl+Ex			Cl+Ex			Cl+Ex				
Detector 2 Channel												
Detector 2 Extend (s)		0.0			0.0			0.0				

Lanes, Volumes, Timings

2028 Opening Year Alter. A Conditions

10: US 101 NB Off Ramp/Lakewood Drive & Old Redwood Highway

Timing Plan: A.M. PEAK



Lane Group	EBL	EBT	EBR	WBL	WBT	WBR	NBL	NBT	NBR	SBL	SBT	SBR
Turn Type	Prot	NA			NA		Split	NA		Prot		pm+ov
Protected Phases	5	2			6		8	8		7		5
Permitted Phases												5 8
Detector Phase	5	2			6		8	8		7		5
Switch Phase												
Minimum Initial (s)	7.0	10.0			10.0		10.0	10.0		7.0		7.0
Minimum Split (s)	11.0	32.1			32.1		33.7	33.7		11.0		11.0
Total Split (s)	13.0	45.3			32.3		33.7	33.7		11.0		13.0
Total Split (%)	14.4%	50.3%			35.9%		37.4%	37.4%		12.2%		14.4%
Maximum Green (s)	9.0	40.2			27.2		29.0	29.0		7.0		9.0
Yellow Time (s)	3.0	4.1			4.1		3.7	3.7		3.0		3.0
All-Red Time (s)	1.0	1.0			1.0		1.0	1.0		1.0		1.0
Lost Time Adjust (s)	0.0	0.0			0.0		0.0	0.0		0.0		0.0
Total Lost Time (s)	4.0	5.1			5.1		4.7	4.7		4.0		4.0
Lead/Lag	Lead				Lag		Lag	Lag		Lead		Lead
Lead-Lag Optimize?	Yes				Yes		Yes	Yes		Yes		Yes
Vehicle Extension (s)	3.0	3.0			3.0		3.0	3.0		3.0		3.0
Recall Mode	None	Max			Max		None	None		None		None
Walk Time (s)		7.0			7.0		7.0	7.0				
Flash Don't Walk (s)		20.0			17.0		22.0	22.0				
Pedestrian Calls (#/hr)		0			0		0	0				
Act Effct Green (s)	8.6	40.4			27.7		17.7	17.7		7.0		31.1
Actuated g/C Ratio	0.11	0.51			0.35		0.22	0.22		0.09		0.39
v/c Ratio	0.54	0.24			0.68		0.61	0.59		0.50		0.86
Control Delay (s/veh)	40.3	12.8			24.9		34.9	27.7		41.8		25.1
Queue Delay	0.0	0.0			0.0		0.0	0.0		0.0		0.0
Total Delay (s/veh)	40.3	12.8			24.9		34.9	27.7		41.8		25.1
LOS	D	B			C		C	C		D		C
Approach Delay (s/veh)		25.7			24.9			30.1				28.1
Approach LOS		C			C			C				C

Intersection Summary

Area Type: Other  
 Cycle Length: 90  
 Actuated Cycle Length: 79  
 Natural Cycle: 90  
 Control Type: Actuated-Uncoordinated  
 Maximum v/c Ratio: 0.86  
 Intersection Signal Delay (s/veh): 27.2  
 Intersection LOS: C  
 Intersection Capacity Utilization 81.6%  
 ICU Level of Service D  
 Analysis Period (min) 15

Splits and Phases: 10: US 101 NB Off Ramp/Lakewood Drive & Old Redwood Highway

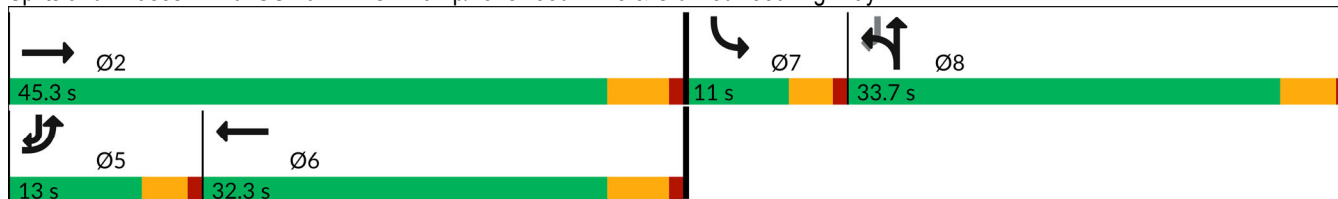

Lanes, Volumes, Timings  
 11: Old Redwood Highway & US 101 NB On Ramp

2028 Opening Year Alter. A Conditions

Timing Plan: A.M. PEAK

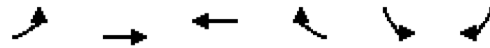

Lane Group	EBL	EBT	WBT	WBR	SBL	SBR
Lane Configurations	↶	↷	↶	↷		
Traffic Volume (vph)	98	368	1152	216	0	0
Future Volume (vph)	98	368	1152	216	0	0
Ideal Flow (vphp)	1900	1900	1900	1900	1900	1900
Storage Length (ft)	245			0	0	0
Storage Lanes	1			0	0	0
Taper Length (ft)	50				25	
Lane Util. Factor	1.00	0.95	0.95	0.95	1.00	1.00
Ped Bike Factor						
Frt			0.976			
Flt Protected	0.950					
Satd. Flow (prot)	1770	3539	3454	0	0	0
Flt Permitted	0.950					
Satd. Flow (perm)	1770	3539	3454	0	0	0
Link Speed (mph)		35	35		30	
Link Distance (ft)		531	226		299	
Travel Time (s)		10.3	4.4		6.8	
Confl. Peds. (#/hr)	9					
Confl. Bikes (#/hr)				1		
Peak Hour Factor	0.81	0.81	0.89	0.89	0.25	0.25
Adj. Flow (vph)	121	454	1294	243	0	0
Shared Lane Traffic (%)						
Lane Group Flow (vph)	121	454	1537	0	0	0
Enter Blocked Intersection	No	No	No	No	No	No
Lane Alignment	Left	Left	Left	Right	Left	Right
Median Width(ft)		12	12		0	
Link Offset(ft)		0	0		0	
Crosswalk Width(ft)		16	16		16	
Two way Left Turn Lane						
Headway Factor	1.00	1.00	1.00	1.00	1.00	1.00
Turning Speed (mph)	15			9	15	9
Sign Control		Free	Free		Free	

Intersection Summary	
Area Type:	Other
Control Type:	Unsignalized
Intersection Capacity Utilization	74.7%
Analysis Period (min)	15
	ICU Level of Service D

Lanes, Volumes, Timings

2028 Opening Year Alter. A Conditions

12: US 101 SB On Ramp/US 101 SB Off Ramp & Old Redwood Highway

Timing Plan: A.M. PEAK



Lane Group	EBL	EBT	EBR	WBL	WBT	WBR	NBL	NBT	NBR	SBL	SBT	SBR
Lane Configurations		↑↑	↗	↘	↑↑					↘	↕	
Traffic Volume (vph)	0	339	337	584	574	0	0	0	0	133	1	74
Future Volume (vph)	0	339	337	584	574	0	0	0	0	133	1	74
Ideal Flow (vphpl)	1900	1900	1900	1900	1900	1900	1900	1900	1900	1900	1900	1900
Storage Length (ft)	0		0	250		0	0		0	420		0
Storage Lanes	0		1	0		0	0		0	1		0
Taper Length (ft)	25			165			25			75		
Lane Util. Factor	1.00	0.95	1.00	1.00	0.95	1.00	1.00	1.00	1.00	0.95	0.95	1.00
Ped Bike Factor			0.98	1.00								
Frt			0.850								0.889	
Flt Protected				0.950						0.950	0.988	
Satd. Flow (prot)	0	3539	1583	1770	3539	0	0	0	0	1681	1554	0
Flt Permitted				0.950						0.950	0.988	
Satd. Flow (perm)	0	3539	1558	1767	3539	0	0	0	0	1681	1554	0
Right Turn on Red			Yes			Yes			Yes			Yes
Satd. Flow (RTOR)			350								91	
Link Speed (mph)		35			35			30			30	
Link Distance (ft)		423			531			621			831	
Travel Time (s)		8.2			10.3			14.1			18.9	
Confl. Peds. (#/hr)	10		3	3		10						
Confl. Bikes (#/hr)			2									
Peak Hour Factor	0.92	0.92	0.92	0.89	0.89	0.89	0.25	0.25	0.25	0.81	0.81	0.81
Adj. Flow (vph)	0	368	366	656	645	0	0	0	0	164	1	91
Shared Lane Traffic (%)										19%		
Lane Group Flow (vph)	0	368	366	656	645	0	0	0	0	133	123	0
Enter Blocked Intersection	No	No	No	No	No	No	No	No	No	No	No	No
Lane Alignment	Left	Left	Right	Left	Left	Right	Left	Left	Right	Left	Left	Right
Median Width(ft)		24			24			12			12	
Link Offset(ft)		0			0			0			0	
Crosswalk Width(ft)		16			16			16			16	
Two way Left Turn Lane												
Headway Factor	1.00	1.00	1.00	1.00	1.00	1.00	1.00	1.00	1.00	1.00	1.00	1.00
Turning Speed (mph)	15		9	15		9	15		9	15		9
Number of Detectors		2	1	1	2					1	2	
Detector Template		Thru	Right	Left	Thru					Left	Thru	
Leading Detector (ft)		100	20	20	100					20	100	
Trailing Detector (ft)		0	0	0	0					0	0	
Detector 1 Position(ft)		0	0	0	0					0	0	
Detector 1 Size(ft)		6	20	20	6					20	6	
Detector 1 Type		Cl+Ex	Cl+Ex	Cl+Ex	Cl+Ex					Cl+Ex	Cl+Ex	
Detector 1 Channel												
Detector 1 Extend (s)		0.0	0.0	0.0	0.0					0.0	0.0	
Detector 1 Queue (s)		0.0	0.0	0.0	0.0					0.0	0.0	
Detector 1 Delay (s)		0.0	0.0	0.0	0.0					0.0	0.0	
Detector 2 Position(ft)		94			94							94
Detector 2 Size(ft)		6			6							6
Detector 2 Type		Cl+Ex			Cl+Ex							Cl+Ex
Detector 2 Channel												
Detector 2 Extend (s)		0.0			0.0							0.0

Lanes, Volumes, Timings

2028 Opening Year Alter. A Conditions

12: US 101 SB On Ramp/US 101 SB Off Ramp & Old Redwood Highway

Timing Plan: A.M. PEAK



Lane Group	EBL	EBT	EBR	WBL	WBT	WBR	NBL	NBT	NBR	SBL	SBT	SBR
Turn Type		NA	Perm	Prot	NA					Perm	NA	
Protected Phases		6		5	2						8	
Permitted Phases			6							8		
Detector Phase		6	6	5	2					8	8	
Switch Phase												
Minimum Initial (s)		10.0	10.0	7.0	10.0					10.0	10.0	
Minimum Split (s)		32.1	32.1	11.0	38.1					14.7	14.7	
Total Split (s)		32.3	32.3	33.0	65.3					14.7	14.7	
Total Split (%)		40.4%	40.4%	41.3%	81.6%					18.4%	18.4%	
Maximum Green (s)		27.2	27.2	29.0	60.2					10.0	10.0	
Yellow Time (s)		4.1	4.1	3.0	4.1					3.7	3.7	
All-Red Time (s)		1.0	1.0	1.0	1.0					1.0	1.0	
Lost Time Adjust (s)		0.0	0.0	0.0	0.0					0.0	0.0	
Total Lost Time (s)		5.1	5.1	4.0	5.1					4.7	4.7	
Lead/Lag		Lag	Lag	Lead								
Lead-Lag Optimize?		Yes	Yes	Yes								
Vehicle Extension (s)		3.0	3.0	3.0	3.0					3.0	3.0	
Recall Mode		Max	Max	None	Max					None	None	
Walk Time (s)		7.0	7.0		7.0							
Flash Don't Walk (s)		20.0	20.0		25.0							
Pedestrian Calls (#/hr)		0	0		0							
Act Effct Green (s)		27.2	27.2	29.0	60.2					10.0	10.0	
Actuated g/C Ratio		0.34	0.34	0.36	0.75					0.13	0.13	
v/c Ratio		0.31	0.48	1.02	0.24					0.63	0.45	
Control Delay (s/veh)		20.3	5.2	69.4	3.2					48.4	17.6	
Queue Delay		0.0	0.0	0.0	0.0					0.0	0.0	
Total Delay (s/veh)		20.3	5.2	69.4	3.2					48.4	17.6	
LOS		C	A	E	A					D	B	
Approach Delay (s/veh)		12.8			36.6						33.6	
Approach LOS		B			D						C	

Intersection Summary

Area Type: Other  
 Cycle Length: 80  
 Actuated Cycle Length: 80  
 Natural Cycle: 80  
 Control Type: Actuated-Uncoordinated  
 Maximum v/c Ratio: 1.02  
 Intersection Signal Delay (s/veh): 28.6  
 Intersection LOS: C  
 Intersection Capacity Utilization 74.7%  
 ICU Level of Service D  
 Analysis Period (min) 15



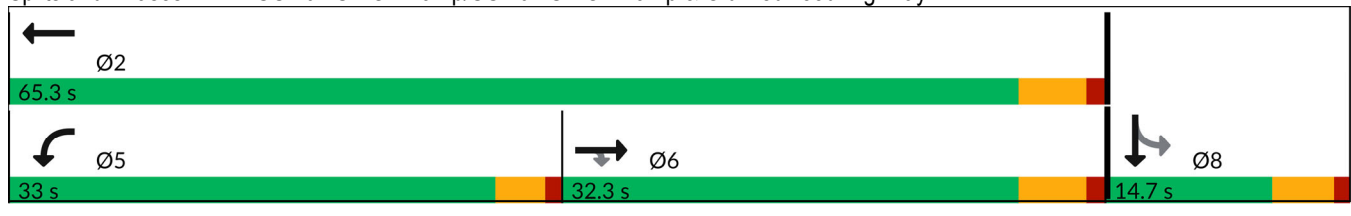



















Splits and Phases: 12: US 101 SB On Ramp/US 101 SB Off Ramp & Old Redwood Highway



Lanes, Volumes, Timings  
1: Old Redwood Hwy & Shiloh Road

2028 Opening Year Alter. A Conditions

Timing Plan: P.M. Peak

												
Lane Group	EBL	EBT	EBR	WBL	WBT	WBR	NBL	NBT	NBR	SBL	SBT	SBR
Lane Configurations												
Traffic Volume (vph)	290	531	308	42	394	57	255	396	24	83	283	183
Future Volume (vph)	290	531	308	42	394	57	255	396	24	83	283	183
Ideal Flow (vphpl)	1900	1900	1900	1900	1900	1900	1900	1900	1900	1900	1900	1900
Storage Length (ft)	375		140	0		50	200		98	130		93
Storage Lanes	1		1	0		1	1		1	1		1
Taper Length (ft)	50			25			60			93		
Lane Util. Factor	1.00	1.00	1.00	1.00	1.00	1.00	1.00	1.00	1.00	1.00	1.00	1.00
Ped Bike Factor	1.00					0.98	1.00		0.98			0.97
Frt			0.850			0.850			0.850			0.850
Flt Protected	0.950				0.995		0.950			0.950		
Satd. Flow (prot)	1770	1863	1583	0	1853	1583	1770	1863	1583	1770	1863	1583
Flt Permitted	0.950				0.995		0.950			0.950		
Satd. Flow (perm)	1768	1863	1583	0	1853	1549	1767	1863	1546	1770	1863	1542
Right Turn on Red			Yes			Yes			Yes			Yes
Satd. Flow (RTOR)			132			105			77			110
Link Speed (mph)		40			40			45			40	
Link Distance (ft)		1789			608			748			775	
Travel Time (s)		30.5			10.4			11.3			13.2	
Confl. Peds. (#/hr)	1						1	1				1
Confl. Bikes (#/hr)									3			3
Peak Hour Factor	0.97	0.97	0.97	0.91	0.91	0.91	0.93	0.93	0.93	0.93	0.93	0.93
Adj. Flow (vph)	299	547	318	46	433	63	274	426	26	89	304	197
Shared Lane Traffic (%)												
Lane Group Flow (vph)	299	547	318	0	479	63	274	426	26	89	304	197
Enter Blocked Intersection	No	No	No	No	No	No	No	No	No	No	No	No
Lane Alignment	Left	Left	Right	Left	Left	Right	Left	Left	Right	Left	Left	Right
Median Width(ft)		12			12			12			12	
Link Offset(ft)		0			0			0			0	
Crosswalk Width(ft)		16			16			16			16	
Two way Left Turn Lane												
Headway Factor	1.00	1.00	1.00	1.00	1.00	1.00	1.00	1.00	1.00	1.00	1.00	1.00
Turning Speed (mph)	15		9	15		9	15		9	15		9
Number of Detectors	1	2	1	1	2	1	1	2	1	1	2	1
Detector Template	Left	Thru	Right	Left	Thru	Right	Left	Thru	Right	Left	Thru	Right
Leading Detector (ft)	20	100	20	20	100	20	20	100	20	20	100	20
Trailing Detector (ft)	0	0	0	0	0	0	0	0	0	0	0	0
Detector 1 Position(ft)	0	0	0	0	0	0	0	0	0	0	0	0
Detector 1 Size(ft)	20	6	20	20	6	20	20	6	20	20	6	20
Detector 1 Type	Cl+Ex	Cl+Ex	Cl+Ex	Cl+Ex	Cl+Ex	Cl+Ex	Cl+Ex	Cl+Ex	Cl+Ex	Cl+Ex	Cl+Ex	Cl+Ex
Detector 1 Channel												
Detector 1 Extend (s)	0.0	0.0	0.0	0.0	0.0	0.0	0.0	0.0	0.0	0.0	0.0	0.0
Detector 1 Queue (s)	0.0	0.0	0.0	0.0	0.0	0.0	0.0	0.0	0.0	0.0	0.0	0.0
Detector 1 Delay (s)	0.0	0.0	0.0	0.0	0.0	0.0	0.0	0.0	0.0	0.0	0.0	0.0
Detector 2 Position(ft)		94			94			94			94	
Detector 2 Size(ft)		6			6			6			6	
Detector 2 Type		Cl+Ex			Cl+Ex			Cl+Ex			Cl+Ex	
Detector 2 Channel												
Detector 2 Extend (s)		0.0			0.0			0.0			0.0	



Lanes, Volumes, Timings  
1: Old Redwood Hwy & Shiloh Road

2028 Opening Year Alter. A Conditions

Timing Plan: P.M. Peak

Lane Group	EBL	EBT	EBR	WBL	WBT	WBR	NBL	NBT	NBR	SBL	SBT	SBR
Turn Type	Split	NA	Perm	Split	NA	Perm	Prot	NA	Perm	Prot	NA	Perm
Protected Phases	2	2		6	6		3	8		7	4	
Permitted Phases			2			6			8			4
Detector Phase	2	2	2	6	6	6	3	8	8	7	4	4
Switch Phase												
Minimum Initial (s)	5.0	5.0	5.0	5.0	5.0	5.0	5.0	5.0	5.0	5.0	5.0	5.0
Minimum Split (s)	34.5	34.5	34.5	42.5	42.5	42.5	8.5	46.5	46.5	8.5	39.5	39.5
Total Split (s)	35.0	35.0	35.0	42.5	42.5	42.5	18.0	48.0	48.0	9.5	39.5	39.5
Total Split (%)	25.9%	25.9%	25.9%	31.5%	31.5%	31.5%	13.3%	35.6%	35.6%	7.0%	29.3%	29.3%
Maximum Green (s)	30.5	30.5	30.5	38.0	38.0	38.0	14.5	43.5	43.5	6.0	35.0	35.0
Yellow Time (s)	3.5	3.5	3.5	3.5	3.5	3.5	3.0	3.5	3.5	3.0	3.5	3.5
All-Red Time (s)	1.0	1.0	1.0	1.0	1.0	1.0	0.5	1.0	1.0	0.5	1.0	1.0
Lost Time Adjust (s)	0.0	0.0	0.0		0.0	0.0	0.0	0.0	0.0	0.0	0.0	0.0
Total Lost Time (s)	4.5	4.5	4.5		4.5	4.5	3.5	4.5	4.5	3.5	4.5	4.5
Lead/Lag	Lead	Lead	Lead	Lag	Lag	Lag	Lead	Lag	Lag	Lead	Lag	Lag
Lead-Lag Optimize?	Yes	Yes	Yes	Yes	Yes	Yes	Yes	Yes	Yes	Yes	Yes	Yes
Vehicle Extension (s)	3.0	3.0	3.0	3.0	3.0	3.0	3.0	3.0	3.0	3.0	3.0	3.0
Recall Mode	None	None	None	None	None	None	None	None	None	None	None	None
Walk Time (s)	7.0	7.0	7.0	7.0	7.0	7.0		7.0	7.0		7.0	7.0
Flash Don't Walk (s)	23.0	23.0	23.0	31.0	31.0	31.0		35.0	35.0		28.0	28.0
Pedestrian Calls (#/hr)	0	0	0	0	0	0		0	0		0	0
Act Effct Green (s)	30.7	30.7	30.7		35.0	35.0	14.6	33.9	33.9	6.0	25.4	25.4
Actuated g/C Ratio	0.25	0.25	0.25		0.29	0.29	0.12	0.28	0.28	0.05	0.21	0.21
v/c Ratio	0.68	1.17	0.64		0.91	0.12	1.30	0.83	0.05	1.02	0.79	0.49
Control Delay (s/veh)	52.4	140.6	31.9		65.5	1.7	209.5	56.5	0.2	162.8	61.7	23.2
Queue Delay	0.0	0.0	0.0		0.0	0.0	0.0	0.0	0.0	0.0	0.0	0.0
Total Delay (s/veh)	52.4	140.6	31.9		65.5	1.7	209.5	56.5	0.2	162.8	61.7	23.2
LOS	D	F	C		E	A	F	E	A	F	E	C
Approach Delay (s/veh)		88.2			58.1			112.2			64.1	
Approach LOS		F			E			F			E	

Intersection Summary

Area Type: Other  
 Cycle Length: 135  
 Actuated Cycle Length: 122.8  
 Natural Cycle: 145  
 Control Type: Actuated-Uncoordinated  
 Maximum v/c Ratio: 1.30  
 Intersection Signal Delay (s/veh): 83.9  
 Intersection LOS: F  
 Intersection Capacity Utilization 95.4%  
 ICU Level of Service F  
 Analysis Period (min) 15



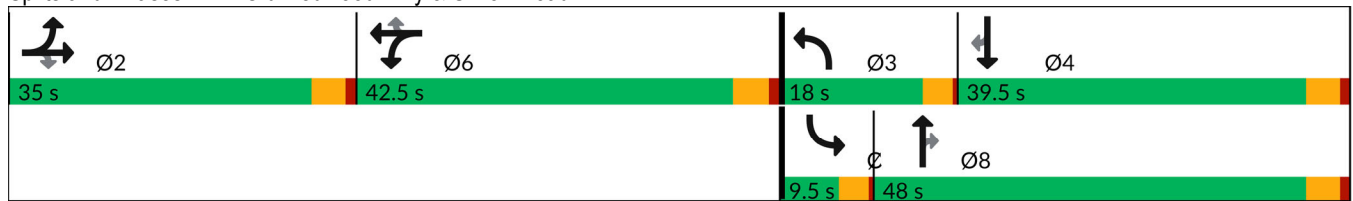





















Splits and Phases: 1: Old Redwood Hwy & Shiloh Road



Lanes, Volumes, Timings  
2: Shiloh Road & Hembree Ln

2028 Opening Year Alter. A Conditions

Timing Plan: P.M. Peak

												
Lane Group	EBL	EBT	EBR	WBL	WBT	WBR	NBL	NBT	NBR	SBL	SBT	SBR
Lane Configurations	 			 	 						 	
Traffic Volume (vph)	700	968	44	24	695	165	65	11	15	194	11	565
Future Volume (vph)	700	968	44	24	695	165	65	11	15	194	11	565
Ideal Flow (vphpl)	1900	1900	1900	1900	1900	1900	1900	1900	1900	1900	1900	1900
Storage Length (ft)	0		0	100		130	0		0	0		0
Storage Lanes	2		0	1		1	1		0	0		1
Taper Length (ft)	25			50			25			25		
Lane Util. Factor	0.97	1.00	1.00	1.00	0.95	0.95	1.00	1.00	1.00	1.00	1.00	1.00
Ped Bike Factor	1.00				1.00							
Frt		0.994			0.971			0.913				0.850
Flt Protected	0.950			0.950			0.950				0.955	
Satd. Flow (prot)	3433	1852	0	1770	3428	0	1770	1701	0	0	1779	1583
Flt Permitted	0.950			0.950			0.950				0.955	
Satd. Flow (perm)	3431	1852	0	1770	3428	0	1770	1701	0	0	1779	1583
Right Turn on Red			Yes			Yes			Yes			Yes
Satd. Flow (RTOR)		4			43			15				128
Link Speed (mph)		40			40			30				35
Link Distance (ft)		302			1789			216				381
Travel Time (s)		5.1			30.5			4.9				7.4
Confl. Peds. (#/hr)	2					2						
Peak Hour Factor	0.94	0.94	1.00	1.00	0.87	0.87	1.00	1.00	1.00	0.95	1.00	0.95
Adj. Flow (vph)	745	1030	44	24	799	190	65	11	15	204	11	595
Shared Lane Traffic (%)												
Lane Group Flow (vph)	745	1074	0	24	989	0	65	26	0	0	215	595
Enter Blocked Intersection	No	No	No	No	No	No	No	No	No	No	No	No
Lane Alignment	Left	Left	Right	Left	Left	Right	Left	Left	Right	Left	Left	Right
Median Width(ft)		24			24			12				12
Link Offset(ft)		0			0			0				0
Crosswalk Width(ft)		16			16			16				16
Two way Left Turn Lane												
Headway Factor	1.00	1.00	1.00	1.00	1.00	1.00	1.00	1.00	1.00	1.00	1.00	1.00
Turning Speed (mph)	15		60	60		9	60		60	15		9
Number of Detectors	1	2		1	2		1	2		1	2	1
Detector Template	Left	Thru		Left	Thru		Left	Thru		Left	Thru	Right
Leading Detector (ft)	20	100		20	100		20	100		20	100	20
Trailing Detector (ft)	0	0		0	0		0	0		0	0	0
Detector 1 Position(ft)	0	0		0	0		0	0		0	0	0
Detector 1 Size(ft)	20	6		20	6		20	6		20	6	20
Detector 1 Type	Cl+Ex	Cl+Ex		Cl+Ex	Cl+Ex		Cl+Ex	Cl+Ex		Cl+Ex	Cl+Ex	Cl+Ex
Detector 1 Channel												
Detector 1 Extend (s)	0.0	0.0		0.0	0.0		0.0	0.0		0.0	0.0	0.0
Detector 1 Queue (s)	0.0	0.0		0.0	0.0		0.0	0.0		0.0	0.0	0.0
Detector 1 Delay (s)	0.0	0.0		0.0	0.0		0.0	0.0		0.0	0.0	0.0
Detector 2 Position(ft)		94			94			94				94
Detector 2 Size(ft)		6			6			6				6
Detector 2 Type		Cl+Ex			Cl+Ex			Cl+Ex				Cl+Ex
Detector 2 Channel												
Detector 2 Extend (s)		0.0			0.0			0.0				0.0
Turn Type	Prot	NA		Prot	NA		Split	NA		Split	NA	pt+ov

Lanes, Volumes, Timings  
2: Shiloh Road & Hembree Ln

2028 Opening Year Alter. A Conditions

Timing Plan: P.M. Peak

Lane Group	EBL	EBT	EBR	WBL	WBT	WBR	NBL	NBT	NBR	SBL	SBT	SBR
Protected Phases	5	2		1	6		8	8		4	4	4 5
Permitted Phases												
Detector Phase	5	2		1	6		8	8		4	4	4 5
Switch Phase												
Minimum Initial (s)	3.0	5.0		5.0	5.0		5.0	5.0		5.0	5.0	
Minimum Split (s)	7.5	9.5		9.5	43.5		9.5	9.5		9.5	9.5	
Total Split (s)	21.0	57.0		9.5	45.5		9.5	9.5		14.0	14.0	
Total Split (%)	23.3%	63.3%		10.6%	50.6%		10.6%	10.6%		15.6%	15.6%	
Maximum Green (s)	17.0	53.0		5.5	41.5		5.5	5.5		10.0	10.0	
Yellow Time (s)	3.0	3.0		3.0	3.0		3.0	3.0		3.0	3.0	
All-Red Time (s)	1.0	1.0		1.0	1.0		1.0	1.0		1.0	1.0	
Lost Time Adjust (s)	0.0	0.0		0.0	0.0		0.0	0.0			0.0	
Total Lost Time (s)	4.0	4.0		4.0	4.0		4.0	4.0			4.0	
Lead/Lag	Lead	Lag		Lead	Lag							
Lead-Lag Optimize?	Yes	Yes		Yes	Yes							
Vehicle Extension (s)	3.0	3.0		3.0	3.0		3.0	3.0		3.0	3.0	
Recall Mode	None	None		None	None		None	None		None	None	
Walk Time (s)					7.0							
Flash Don't Walk (s)					32.0							
Pedestrian Calls (#/hr)					1							
Act Effct Green (s)	17.4	50.8		5.6	32.6		5.6	5.6		10.3	28.8	
Actuated g/C Ratio	0.22	0.64		0.07	0.41		0.07	0.07		0.13	0.36	
v/c Ratio	0.99	0.91		0.19	0.69		0.52	0.19		0.94	0.91	
Control Delay (s/veh)	66.7	28.0		43.0	21.2		56.1	28.5		87.1	40.2	
Queue Delay	0.0	1.4		0.0	0.0		0.0	0.0		0.0	0.0	
Total Delay (s/veh)	66.7	29.4		43.0	21.2		56.1	28.5		87.1	40.2	
LOS	E	C		D	C		E	C		F	D	
Approach Delay (s/veh)		44.7			21.7			48.2			52.7	
Approach LOS		D			C			D			D	

Intersection Summary

Area Type:	Other
Cycle Length:	90
Actuated Cycle Length:	79.8
Natural Cycle:	100
Control Type:	Actuated-Uncoordinated
Maximum v/c Ratio:	0.99
Intersection Signal Delay (s/veh):	40.3
Intersection LOS:	D
Intersection Capacity Utilization:	85.8%
ICU Level of Service:	E
Analysis Period (min):	15

Splits and Phases: 2: Shiloh Road & Hembree Ln



Lanes, Volumes, Timings  
3: US 101 NB Off-Ramp & Shiloh Road

2028 Opening Year Alter. A Conditions  
Timing Plan: P.M. Peak

	→	↘	↙	←	↖	↗
Lane Group	EBT	EBR	WBL	WBT	NBL	NBR
Lane Configurations	↑↑			↑	↘	↗↗
Traffic Volume (vph)	648	0	0	916	599	1069
Future Volume (vph)	648	0	0	916	599	1069
Ideal Flow (vphpl)	1900	1900	1900	1900	1900	1900
Storage Length (ft)		0	0		0	265
Storage Lanes		0	0		1	2
Taper Length (ft)			25		25	
Lane Util. Factor	0.95	1.00	1.00	1.00	1.00	0.88
Frt						0.850
Flt Protected					0.950	
Satd. Flow (prot)	3539	0	0	1863	1770	2787
Flt Permitted					0.950	
Satd. Flow (perm)	3539	0	0	1863	1770	2787
Right Turn on Red		Yes				Yes
Satd. Flow (RTOR)						266
Link Speed (mph)	40			40	30	
Link Distance (ft)	186			371	769	
Travel Time (s)	3.2			6.3	17.5	
Peak Hour Factor	0.94	0.94	0.97	0.97	0.90	0.90
Adj. Flow (vph)	689	0	0	944	666	1188
Shared Lane Traffic (%)						
Lane Group Flow (vph)	689	0	0	944	666	1188
Enter Blocked Intersection	No	No	No	No	No	No
Lane Alignment	Left	Right	Left	Left	Left	Right
Median Width(ft)	0			0	12	
Link Offset(ft)	0			0	0	
Crosswalk Width(ft)	16			16	16	
Two way Left Turn Lane						
Headway Factor	1.00	1.00	1.00	1.00	1.00	1.00
Turning Speed (mph)		9	15		15	9
Number of Detectors	2			2	1	1
Detector Template	Thru			Thru	Left	Right
Leading Detector (ft)	100			100	20	20
Trailing Detector (ft)	0			0	0	0
Detector 1 Position(ft)	0			0	0	0
Detector 1 Size(ft)	6			6	20	20
Detector 1 Type	Cl+Ex			Cl+Ex	Cl+Ex	Cl+Ex
Detector 1 Channel						
Detector 1 Extend (s)	0.0			0.0	0.0	0.0
Detector 1 Queue (s)	0.0			0.0	0.0	0.0
Detector 1 Delay (s)	0.0			0.0	0.0	0.0
Detector 2 Position(ft)	94			94		
Detector 2 Size(ft)	6			6		
Detector 2 Type	Cl+Ex			Cl+Ex		
Detector 2 Channel						
Detector 2 Extend (s)	0.0			0.0		
Turn Type	NA			NA	Prot	Perm
Protected Phases	2			6	8	
Permitted Phases						8

Lanes, Volumes, Timings  
 3: US 101 NB Off-Ramp & Shiloh Road

2028 Opening Year Alter. A Conditions  
 Timing Plan: P.M. Peak



Lane Group	EBT	EBR	WBL	WBT	NBL	NBR
Detector Phase	2			6	8	8
Switch Phase						
Minimum Initial (s)	5.0			5.0	5.0	5.0
Minimum Split (s)	9.0			9.0	9.0	9.0
Total Split (s)	37.0			37.0	35.0	35.0
Total Split (%)	51.4%			51.4%	48.6%	48.6%
Maximum Green (s)	33.0			33.0	31.0	31.0
Yellow Time (s)	3.0			3.0	3.0	3.0
All-Red Time (s)	1.0			1.0	1.0	1.0
Lost Time Adjust (s)	0.0			0.0	0.0	0.0
Total Lost Time (s)	4.0			4.0	4.0	4.0
Lead/Lag						
Lead-Lag Optimize?						
Vehicle Extension (s)	3.0			3.0	3.0	3.0
Recall Mode	None			None	None	None
Act Effect Green (s)	33.0			33.0	29.8	29.8
Actuated g/C Ratio	0.47			0.47	0.42	0.42
v/c Ratio	0.42			1.09	0.90	0.90
Control Delay (s/veh)	13.8			79.1	36.3	25.4
Queue Delay	0.0			0.0	0.0	0.0
Total Delay (s/veh)	13.8			79.1	36.3	25.4
LOS	B			E	D	C
Approach Delay (s/veh)	13.8			79.1	29.3	
Approach LOS	B			E	C	

Intersection Summary

Area Type:	Other
Cycle Length:	72
Actuated Cycle Length:	70.8
Natural Cycle:	80
Control Type:	Actuated-Uncoordinated
Maximum v/c Ratio:	1.09
Intersection Signal Delay (s/veh):	39.7
Intersection LOS:	D
Intersection Capacity Utilization:	149.3%
ICU Level of Service:	H
Analysis Period (min):	15

Splits and Phases: 3: US 101 NB Off-Ramp & Shiloh Road

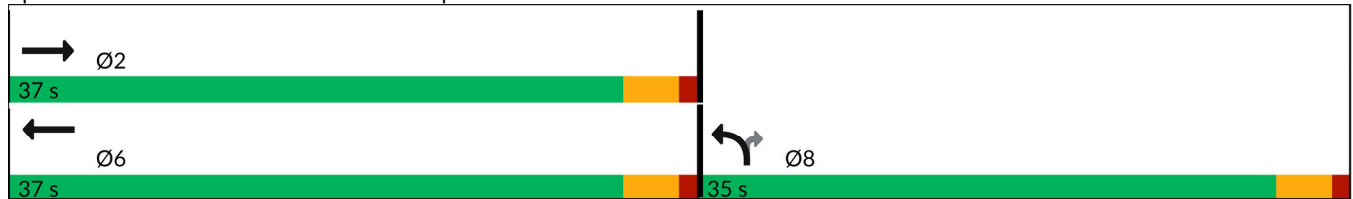

Lanes, Volumes, Timings  
4: Shiloh Road & US 101 SB Off-Ramp

2028 Opening Year Alter. A Conditions

Timing Plan: P.M. Peak

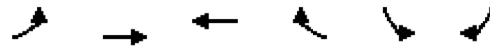

Lane Group	EBL	EBT	WBT	WBR	SBL	SBR
Lane Configurations		↑	↑		↘	↘
Traffic Volume (vph)	0	533	739	0	318	146
Future Volume (vph)	0	533	739	0	318	146
Ideal Flow (vphp)	1900	1900	1900	1900	1900	1900
Storage Length (ft)	0			0	0	275
Storage Lanes	0			0	1	1
Taper Length (ft)	25				25	
Lane Util. Factor	1.00	1.00	1.00	1.00	1.00	1.00
Ped Bike Factor						0.98
Frt						0.850
Flt Protected					0.950	
Satd. Flow (prot)	0	1863	1863	0	1770	1583
Flt Permitted					0.950	
Satd. Flow (perm)	0	1863	1863	0	1770	1548
Right Turn on Red				Yes		Yes
Satd. Flow (RTOR)						157
Link Speed (mph)		40	40		30	
Link Distance (ft)		225	306		486	
Travel Time (s)		3.8	5.2		11.0	
Confl. Peds. (#/hr)						1
Peak Hour Factor	0.89	0.89	0.96	0.96	0.93	0.93
Adj. Flow (vph)	0	599	770	0	342	157
Shared Lane Traffic (%)						
Lane Group Flow (vph)	0	599	770	0	342	157
Enter Blocked Intersection	No	No	No	No	No	No
Lane Alignment	Left	Left	Left	Right	Left	Right
Median Width(ft)		4	0		12	
Link Offset(ft)		0	0		0	
Crosswalk Width(ft)		16	16		16	
Two way Left Turn Lane						
Headway Factor	1.00	1.00	1.00	1.00	1.00	1.00
Turning Speed (mph)	15			9	15	9
Number of Detectors		2	2		1	1
Detector Template		Thru	Thru		Left	Right
Leading Detector (ft)		100	100		20	20
Trailing Detector (ft)		0	0		0	0
Detector 1 Position(ft)		0	0		0	0
Detector 1 Size(ft)		6	6		20	20
Detector 1 Type		Cl+Ex	Cl+Ex		Cl+Ex	Cl+Ex
Detector 1 Channel						
Detector 1 Extend (s)		0.0	0.0		0.0	0.0
Detector 1 Queue (s)		0.0	0.0		0.0	0.0
Detector 1 Delay (s)		0.0	0.0		0.0	0.0
Detector 2 Position(ft)		94	94			
Detector 2 Size(ft)		6	6			
Detector 2 Type		Cl+Ex	Cl+Ex			
Detector 2 Channel						
Detector 2 Extend (s)		0.0	0.0			
Turn Type		NA	NA		Perm	Perm

Lanes, Volumes, Timings  
4: Shiloh Road & US 101 SB Off-Ramp

2028 Opening Year Alter. A Conditions  
Timing Plan: P.M. Peak

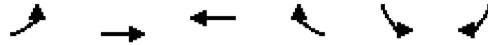

Lane Group	EBL	EBT	WBT	WBR	SBL	SBR
Protected Phases		2	6			
Permitted Phases					4	4
Detector Phase		2	6		4	4
Switch Phase						
Minimum Initial (s)		5.0	5.0		5.0	5.0
Minimum Split (s)		9.0	38.0		9.0	9.0
Total Split (s)		69.0	69.0		21.0	21.0
Total Split (%)		76.7%	76.7%		23.3%	23.3%
Maximum Green (s)		65.0	65.0		17.0	17.0
Yellow Time (s)		3.0	3.0		3.0	3.0
All-Red Time (s)		1.0	1.0		1.0	1.0
Lost Time Adjust (s)		0.0	0.0		0.0	0.0
Total Lost Time (s)		4.0	4.0		4.0	4.0
Lead/Lag						
Lead-Lag Optimize?						
Vehicle Extension (s)		3.0	3.0		3.0	3.0
Recall Mode		None	None		None	None
Walk Time (s)			7.0			
Flash Don't Walk (s)			27.0			
Pedestrian Calls (#/hr)			0			
Act Effct Green (s)		27.1	27.1		17.4	17.4
Actuated g/C Ratio		0.52	0.52		0.33	0.33
v/c Ratio		0.63	0.80		0.59	0.26
Control Delay (s/veh)		11.9	17.5		22.8	5.1
Queue Delay		0.0	0.0		0.0	0.0
Total Delay (s/veh)		11.9	17.5		22.8	5.1
LOS		B	B		C	A
Approach Delay (s/veh)		11.9	17.5		17.2	
Approach LOS		B	B		B	

Intersection Summary

Area Type:	Other
Cycle Length:	90
Actuated Cycle Length:	52.6
Natural Cycle:	55
Control Type:	Actuated-Uncoordinated
Maximum v/c Ratio:	0.80
Intersection Signal Delay (s/veh):	15.6
Intersection LOS:	B
Intersection Capacity Utilization:	134.7%
ICU Level of Service:	H
Analysis Period (min):	15

Splits and Phases: 4: Shiloh Road & US 101 SB Off-Ramp

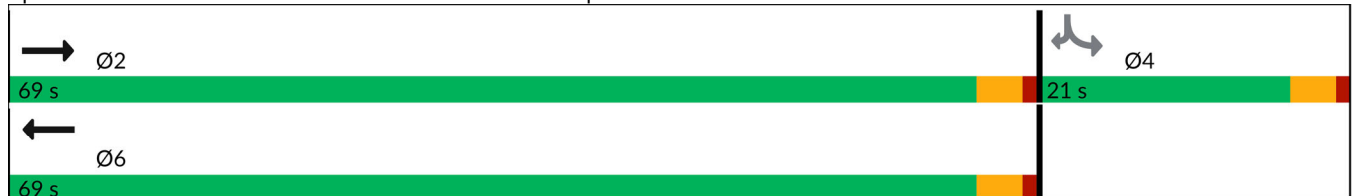

Lanes, Volumes, Timings  
5: Caletti Ave & Shiloh Road

2028 Opening Year Alter. A Conditions

Timing Plan: P.M. Peak

	→	↘	↙	←	↖	↗
Lane Group	EBT	EBR	WBL	WBT	NBL	NBR
Lane Configurations	↑↑		↙	↑	↘	↗
Traffic Volume (vph)	1004	32	90	766	17	170
Future Volume (vph)	1004	32	90	766	17	170
Ideal Flow (vphpl)	1900	1900	1900	1900	1900	1900
Storage Length (ft)		0	68		0	0
Storage Lanes		0	1		1	1
Taper Length (ft)			50		25	
Lane Util. Factor	0.95	0.95	1.00	1.00	1.00	1.00
Frt	0.995					0.850
Flt Protected			0.950		0.950	
Satd. Flow (prot)	3522	0	1770	1863	1770	1583
Flt Permitted			0.950		0.950	
Satd. Flow (perm)	3522	0	1770	1863	1770	1583
Link Speed (mph)	40			40	30	
Link Distance (ft)	1081			184	459	
Travel Time (s)	18.4			3.1	10.4	
Peak Hour Factor	0.89	0.89	0.92	0.92	0.89	0.89
Adj. Flow (vph)	1128	36	98	833	19	191
Shared Lane Traffic (%)						
Lane Group Flow (vph)	1164	0	98	833	19	191
Enter Blocked Intersection	No	No	No	No	No	No
Lane Alignment	Left	Right	Left	Left	Left	Right
Median Width(ft)	12			12	12	
Link Offset(ft)	0			0	0	
Crosswalk Width(ft)	16			16	16	
Two way Left Turn Lane						
Headway Factor	1.00	1.00	1.00	1.00	1.00	1.00
Turning Speed (mph)		9	15		15	9
Sign Control	Free			Free	Stop	

Intersection Summary



















Area Type:	Other
Control Type:	Unsignalized
Intersection Capacity Utilization	50.3%
ICU Level of Service	A
Analysis Period (min)	15



Lanes, Volumes, Timings  
6: Conde Lane & Shiloh Road

2028 Opening Year Alter. A Conditions

Timing Plan: P.M. Peak

												
Lane Group	EBL	EBT	EBR	WBL	WBT	WBR	NBL	NBT	NBR	SBL	SBT	SBR
Lane Configurations												
Traffic Volume (vph)	79	570	2	8	544	329	6	3	19	338	0	44
Future Volume (vph)	79	570	2	8	544	329	6	3	19	338	0	44
Ideal Flow (vphpl)	1900	1900	1900	1900	1900	1900	1900	1900	1900	1900	1900	1900
Storage Length (ft)	90		0	127		0	0		0	0		40
Storage Lanes	1		0	1		0	0		0	0		1
Taper Length (ft)	70			40			25			25		
Lane Util. Factor	1.00	0.95	0.95	1.00	0.95	0.95	1.00	1.00	1.00	1.00	1.00	1.00
Ped Bike Factor	1.00				0.99							
Frt					0.943			0.910				0.850
Flt Protected	0.950			0.950				0.989			0.950	
Satd. Flow (prot)	1770	3539	0	1770	3311	0	0	1676	0	0	1770	1583
Flt Permitted	0.950			0.950				0.989			0.950	
Satd. Flow (perm)	1767	3539	0	1770	3311	0	0	1676	0	0	1770	1583
Right Turn on Red			Yes			Yes			Yes			No
Satd. Flow (RTOR)					132			30				
Link Speed (mph)		40			40			30				35
Link Distance (ft)		815			1081			418				522
Travel Time (s)		13.9			18.4			9.5				10.2
Confl. Peds. (#/hr)	1						1					
Peak Hour Factor	0.88	0.88	0.88	0.80	0.80	0.80	0.63	0.63	0.63	0.88	0.88	0.88
Adj. Flow (vph)	90	648	2	10	680	411	10	5	30	384	0	50
Shared Lane Traffic (%)												
Lane Group Flow (vph)	90	650	0	10	1091	0	0	45	0	0	384	50
Enter Blocked Intersection	No	No	No	No	No	No	No	No	No	No	No	No
Lane Alignment	Left	Left	Right	Left	Left	Right	Left	Left	Right	Left	Left	Right
Median Width(ft)		12			12			0				0
Link Offset(ft)		0			0			0				0
Crosswalk Width(ft)		16			16			16				16
Two way Left Turn Lane												
Headway Factor	1.00	1.00	1.00	1.00	1.00	1.00	1.00	1.00	1.00	1.00	1.00	1.00
Turning Speed (mph)	15		9	15		9	15		9	15		9
Number of Detectors	1	2		1	2		1	2		1	1	1
Detector Template	Left	Thru		Left	Thru		Left	Thru		Left	Thru	Right
Leading Detector (ft)	20	100		20	100		20	100		20	30	20
Trailing Detector (ft)	0	0		0	0		0	0		0	0	0
Detector 1 Position(ft)	0	0		0	0		0	0		0	0	0
Detector 1 Size(ft)	20	6		20	6		20	6		20	30	20
Detector 1 Type	Cl+Ex	Cl+Ex		Cl+Ex	Cl+Ex		Cl+Ex	Cl+Ex		Cl+Ex	Cl+Ex	Cl+Ex
Detector 1 Channel												
Detector 1 Extend (s)	0.0	0.0		0.0	0.0		0.0	0.0		0.0	0.0	0.0
Detector 1 Queue (s)	0.0	0.0		0.0	0.0		0.0	0.0		0.0	0.0	0.0
Detector 1 Delay (s)	0.0	0.0		0.0	0.0		0.0	0.0		0.0	0.0	0.0
Detector 2 Position(ft)		94			94			94				
Detector 2 Size(ft)		6			6			6				
Detector 2 Type		Cl+Ex			Cl+Ex			Cl+Ex				
Detector 2 Channel												
Detector 2 Extend (s)		0.0			0.0			0.0				
Turn Type	Prot	NA		Prot	NA		Split	NA		Split	NA	custom

Lanes, Volumes, Timings  
6: Conde Lane & Shiloh Road

2028 Opening Year Alter. A Conditions

Timing Plan: P.M. Peak

Lane Group	EBL	EBT	EBR	WBL	WBT	WBR	NBL	NBT	NBR	SBL	SBT	SBR
Protected Phases	5	2		1	6		7	7		4	4	
Permitted Phases												6
Detector Phase	5	2		1	6		7	7		4	4	6
Switch Phase												
Minimum Initial (s)	8.0	8.0		8.0	8.0		10.0	10.0		11.0	11.0	8.0
Minimum Split (s)	12.0	46.0		12.0	12.0		37.0	37.0		15.0	15.0	12.0
Total Split (s)	13.0	46.0		12.0	45.0		37.0	37.0		15.0	15.0	45.0
Total Split (%)	11.8%	41.8%		10.9%	40.9%		33.6%	33.6%		13.6%	13.6%	40.9%
Maximum Green (s)	9.0	42.0		8.0	41.0		33.0	33.0		11.0	11.0	41.0
Yellow Time (s)	3.0	3.0		3.0	3.0		3.0	3.0		3.0	3.0	3.0
All-Red Time (s)	1.0	1.0		1.0	1.0		1.0	1.0		1.0	1.0	1.0
Lost Time Adjust (s)	0.0	0.0		0.0	0.0		0.0	0.0		0.0	0.0	0.0
Total Lost Time (s)	4.0	4.0		4.0	4.0		4.0	4.0		4.0	4.0	4.0
Lead/Lag	Lead	Lag		Lead	Lag							Lag
Lead-Lag Optimize?	Yes	Yes		Yes	Yes							Yes
Vehicle Extension (s)	3.0	3.0		3.0	3.0		3.0	3.0		3.0	3.0	3.0
Recall Mode	None	None		None	None		None	None		None	None	None
Walk Time (s)		7.0					7.0	7.0				
Flash Don't Walk (s)		35.0					26.0	26.0				
Pedestrian Calls (#/hr)		0					0	0				
Act Effct Green (s)	9.6	36.2		9.1	28.8			11.4			12.6	28.8
Actuated g/C Ratio	0.14	0.54		0.14	0.43			0.17			0.19	0.43
v/c Ratio	0.35	0.34		0.04	0.73			0.14			1.15	0.07
Control Delay (s/veh)	37.8	9.8		35.3	17.7			19.1			132.1	13.3
Queue Delay	0.0	0.0		0.0	0.0			0.0			0.0	0.0
Total Delay (s/veh)	37.8	9.8		35.3	17.7			19.1			132.1	13.3
LOS	D	A		D	B			B			F	B
Approach Delay (s/veh)		13.2			17.9			19.1			118.5	
Approach LOS		B			B			B			F	

Intersection Summary

Area Type:	Other
Cycle Length:	110
Actuated Cycle Length:	66.6
Natural Cycle:	120
Control Type:	Actuated-Uncoordinated
Maximum v/c Ratio:	1.15
Intersection Signal Delay (s/veh):	35.2
Intersection LOS:	D
Intersection Capacity Utilization:	67.7%
ICU Level of Service:	C
Analysis Period (min):	15



















Splits and Phases: 6: Conde Lane & Shiloh Road



Lanes, Volumes, Timings  
7: Driveway 1/Gridley Drive & Shiloh Road

2028 Opening Year Alter. A Conditions

Timing Plan: P.M. Peak



















												
Lane Group	EBL	EBT	EBR	WBL	WBT	WBR	NBL	NBT	NBR	SBL	SBT	SBR
Lane Configurations												
Traffic Volume (vph)	19	486	121	0	400	0	84	0	0	0	0	16
Future Volume (vph)	19	486	121	0	400	0	84	0	0	0	0	16
Ideal Flow (vphpl)	1900	1900	1900	1900	1900	1900	1900	1900	1900	1900	1900	1900
Storage Length (ft)	0		150	0		0	0		0	0		0
Storage Lanes	0		1	0		0	1		0	0		0
Taper Length (ft)	25			25			25			25		
Lane Util. Factor	1.00	1.00	1.00	1.00	1.00	1.00	1.00	1.00	1.00	1.00	1.00	1.00
Ped Bike Factor												
Frt			0.850									0.865
Flt Protected		0.998					0.950					
Satd. Flow (prot)	0	1859	1583	0	1863	0	1770	1863	0	0	1611	0
Flt Permitted		0.998					0.950					
Satd. Flow (perm)	0	1859	1583	0	1863	0	1770	1863	0	0	1611	0
Link Speed (mph)		40			40			30			30	
Link Distance (ft)		608			2146			248			715	
Travel Time (s)		10.4			36.6			5.6			16.3	
Confl. Peds. (#/hr)	1											
Confl. Bikes (#/hr)			1									
Peak Hour Factor	0.94	0.94	0.94	0.69	0.69	0.69	1.00	1.00	1.00	0.58	0.58	0.58
Adj. Flow (vph)	20	517	129	0	580	0	84	0	0	0	0	28
Shared Lane Traffic (%)												
Lane Group Flow (vph)	0	537	129	0	580	0	84	0	0	0	28	0
Enter Blocked Intersection	No	No	No	No	No	No	No	No	No	No	No	No
Lane Alignment	Left	Left	Right	Left	Left	Right	Left	Left	Right	Left	Left	Right
Median Width(ft)		0			0			12			12	
Link Offset(ft)		0			0			0			0	
Crosswalk Width(ft)		16			16			16			16	
Two way Left Turn Lane												
Headway Factor	1.00	1.00	1.00	1.00	1.00	1.00	1.00	1.00	1.00	1.00	1.00	1.00
Turning Speed (mph)	15		9	15		9	15		9	15		9
Sign Control		Free			Free			Stop			Stop	

Intersection Summary	
Area Type:	Other
Control Type:	Unsignalized
Intersection Capacity Utilization	59.0%
Analysis Period (min)	15
	ICU Level of Service B

Lanes, Volumes, Timings  
8: Old Redwood Hwy & Driveway 2

2028 Opening Year Alter. A Conditions

Timing Plan: P.M. Peak

												
Lane Group	EBL	EBT	EBR	WBL	WBT	WBR	NBL	NBT	NBR	SBL	SBT	SBR
Lane Configurations												
Traffic Volume (vph)	3	0	0	49	0	79	0	575	71	114	486	0
Future Volume (vph)	3	0	0	49	0	79	0	575	71	114	486	0
Ideal Flow (vphp)	1900	1900	1900	1900	1900	1900	1900	1900	1900	1900	1900	1900
Storage Length (ft)	0		0	0		0	0		100	50		0
Storage Lanes	0		0	1		0	0		1	1		0
Taper Length (ft)	25			25			25			25		
Lane Util. Factor	1.00	1.00	1.00	1.00	1.00	1.00	1.00	1.00	1.00	1.00	1.00	1.00
Ped Bike Factor												
Frt					0.850				0.850			
Flt Protected		0.950		0.950						0.950		
Satd. Flow (prot)	0	1770	0	1770	1583	0	0	1863	1583	1770	1863	0
Flt Permitted		0.950		0.950						0.950		
Satd. Flow (perm)	0	1770	0	1770	1583	0	0	1863	1583	1770	1863	0
Link Speed (mph)		30			30			45			45	
Link Distance (ft)		98			385			520			748	
Travel Time (s)		2.2			8.8			7.9			11.3	
Confl. Bikes (#/hr)									3			5
Peak Hour Factor	0.38	0.38	0.38	1.00	1.00	1.00	0.91	0.91	0.91	0.94	0.94	0.94
Adj. Flow (vph)	8	0	0	49	0	79	0	632	78	121	517	0
Shared Lane Traffic (%)												
Lane Group Flow (vph)	0	8	0	49	79	0	0	632	78	121	517	0
Enter Blocked Intersection	No	No	No	No	No	No	No	No	No	No	No	No
Lane Alignment	Left	Left	Right	Left	Left	Right	Left	Left	Right	Left	Left	Right
Median Width(ft)		12			12			12			12	
Link Offset(ft)		0			0			0			0	
Crosswalk Width(ft)		16			16			16			16	
Two way Left Turn Lane												
Headway Factor	1.00	1.00	1.00	1.00	1.00	1.00	1.00	1.00	1.00	1.00	1.00	1.00
Turning Speed (mph)	15		9	15		9	15		9	15		9
Sign Control		Stop			Stop			Free			Free	
<b>Intersection Summary</b>												
Area Type:	Other											
Control Type:	Unsignalized											
Intersection Capacity Utilization	70.7%						ICU Level of Service C					
Analysis Period (min)	15											

Lanes, Volumes, Timings  
9: Driveway 2 & Shiloh Road

2028 Opening Year Alter. A Conditions

Timing Plan: P.M. Peak

	→	↘	↙	←	↖	↗
Lane Group	EBT	EBR	WBL	WBT	NBL	NBR
Lane Configurations	↑	↗		↖	↘	↗
Traffic Volume (vph)	92	369	35	126	258	25
Future Volume (vph)	92	369	35	126	258	25
Ideal Flow (vphpl)	1900	1900	1900	1900	1900	1900
Storage Length (ft)		200	0		0	0
Storage Lanes		1	0		1	1
Taper Length (ft)			25		25	
Lane Util. Factor	1.00	1.00	1.00	1.00	1.00	1.00
Frt		0.850				0.850
Flt Protected				0.989	0.950	
Satd. Flow (prot)	1863	1583	0	1842	1770	1583
Flt Permitted				0.989	0.950	
Satd. Flow (perm)	1863	1583	0	1842	1770	1583
Link Speed (mph)	40			40	30	
Link Distance (ft)	2146			134	402	
Travel Time (s)	36.6			2.3	9.1	
Peak Hour Factor	0.92	0.92	0.68	0.68	1.00	1.00
Adj. Flow (vph)	100	401	51	185	258	25
Shared Lane Traffic (%)						
Lane Group Flow (vph)	100	401	0	236	258	25
Enter Blocked Intersection	No	No	No	No	No	No
Lane Alignment	Left	Right	Left	Left	Left	Right
Median Width(ft)	0			0	12	
Link Offset(ft)	0			0	0	
Crosswalk Width(ft)	16			16	16	
Two way Left Turn Lane						
Headway Factor	1.00	1.00	1.00	1.00	1.00	1.00
Turning Speed (mph)		9	15		15	9
Sign Control	Free			Free	Stop	

Intersection Summary

Area Type:	Other
Control Type:	Unsignalized
Intersection Capacity Utilization	38.1%
Analysis Period (min)	15
	ICU Level of Service A

Lanes, Volumes, Timings

2028 Opening Year Alter. A Conditions

10: US 101 NB Off Ramp/Lakewood Drive & Old Redwood Highway

Timing Plan: P.M. Peak



Lane Group	EBL	EBT	EBR	WBL	WBT	WBR	NBL	NBT	NBR	SBL	SBT	SBR
Lane Configurations												
Traffic Volume (vph)	297	470	0	0	615	219	569	469	286	284	0	657
Future Volume (vph)	297	470	0	0	615	219	569	469	286	284	0	657
Ideal Flow (vphpl)	1900	1900	1900	1900	1900	1900	1900	1900	1900	1900	1900	1900
Storage Length (ft)	155		0	0		0	270		150	120		0
Storage Lanes	1		0	0		0	1		1	1		1
Taper Length (ft)	50			25			165			75		
Lane Util. Factor	0.97	1.00	1.00	1.00	0.95	0.95	0.91	0.91	0.95	0.97	1.00	1.00
Ped Bike Factor	1.00				0.99			0.99		1.00		
Fr <sub>t</sub>					0.961			0.951				0.850
Fl <sub>t</sub> Protected	0.950						0.950	0.993		0.950		
Satd. Flow (prot)	3433	1863	0	0	3382	0	1610	3181	0	3433	0	1583
Fl <sub>t</sub> Permitted	0.950						0.950	0.993		0.950		
Satd. Flow (perm)	3428	1863	0	0	3382	0	1610	3181	0	3422	0	1583
Right Turn on Red			Yes			Yes			Yes			Yes
Satd. Flow (RTOR)					57			85				265
Link Speed (mph)		35			35			30				30
Link Distance (ft)		226			617			716				478
Travel Time (s)		4.4			12.0			16.3				10.9
Confl. Peds. (#/hr)	3		1	1		3			8	8		
Confl. Bikes (#/hr)			2			9						
Peak Hour Factor	0.87	0.87	0.87	0.91	0.91	0.91	0.92	0.92	0.92	0.96	0.96	0.96
Adj. Flow (vph)	341	540	0	0	676	241	618	510	311	296	0	684
Shared Lane Traffic (%)							22%					
Lane Group Flow (vph)	341	540	0	0	917	0	482	957	0	296	0	684
Enter Blocked Intersection	No	No	No	No	No	No	No	No	No	No	No	No
Lane Alignment	Left	Left	Right	Left	Left	Right	Left	Left	Right	Left	Left	Right
Median Width(ft)		24			24			24				24
Link Offset(ft)		0			0			0				0
Crosswalk Width(ft)		16			16			16				16
Two way Left Turn Lane												
Headway Factor	1.00	1.00	1.00	1.00	1.00	1.00	1.00	1.00	1.00	1.00	1.00	1.00
Turning Speed (mph)	15		9	15		9	15		9	15		9
Number of Detectors	1	2			2		1	2		1		1
Detector Template	Left	Thru			Thru		Left	Thru		Left		Right
Leading Detector (ft)	20	100			100		20	100		20		20
Trailing Detector (ft)	0	0			0		0	0		0		0
Detector 1 Position(ft)	0	0			0		0	0		0		0
Detector 1 Size(ft)	20	6			6		20	6		20		20
Detector 1 Type	Cl+Ex	Cl+Ex			Cl+Ex		Cl+Ex	Cl+Ex		Cl+Ex		Cl+Ex
Detector 1 Channel												
Detector 1 Extend (s)	0.0	0.0			0.0		0.0	0.0		0.0		0.0
Detector 1 Queue (s)	0.0	0.0			0.0		0.0	0.0		0.0		0.0
Detector 1 Delay (s)	0.0	0.0			0.0		0.0	0.0		0.0		0.0
Detector 2 Position(ft)		94			94			94				
Detector 2 Size(ft)		6			6			6				
Detector 2 Type		Cl+Ex			Cl+Ex			Cl+Ex				
Detector 2 Channel												
Detector 2 Extend (s)		0.0			0.0			0.0				

Lanes, Volumes, Timings

2028 Opening Year Alter. A Conditions

10: US 101 NB Off Ramp/Lakewood Drive & Old Redwood Highway

Timing Plan: P.M. Peak



Lane Group	EBL	EBT	EBR	WBL	WBT	WBR	NBL	NBT	NBR	SBL	SBT	SBR
Turn Type	Prot	NA			NA		Split	NA		Prot		pm+ov
Protected Phases	5	2			6		8	8		7		5
Permitted Phases												5 8
Detector Phase	5	2			6		8	8		7		5
Switch Phase												
Minimum Initial (s)	7.0	10.0			10.0		10.0	10.0		7.0		7.0
Minimum Split (s)	11.0	32.1			32.1		33.7	33.7		11.0		11.0
Total Split (s)	13.0	45.3			32.3		33.7	33.7		11.0		13.0
Total Split (%)	14.4%	50.3%			35.9%		37.4%	37.4%		12.2%		14.4%
Maximum Green (s)	9.0	40.2			27.2		29.0	29.0		7.0		9.0
Yellow Time (s)	3.0	4.1			4.1		3.7	3.7		3.0		3.0
All-Red Time (s)	1.0	1.0			1.0		1.0	1.0		1.0		1.0
Lost Time Adjust (s)	0.0	0.0			0.0		0.0	0.0		0.0		0.0
Total Lost Time (s)	4.0	5.1			5.1		4.7	4.7		4.0		4.0
Lead/Lag	Lead				Lag		Lag	Lag		Lead		Lead
Lead-Lag Optimize?	Yes				Yes		Yes	Yes		Yes		Yes
Vehicle Extension (s)	3.0	3.0			3.0		3.0	3.0		3.0		3.0
Recall Mode	None	Max			Max		None	None		None		None
Walk Time (s)		7.0			7.0		7.0	7.0				
Flash Don't Walk (s)		20.0			17.0		22.0	22.0				
Pedestrian Calls (#/hr)		0			0		0	0				
Act Effct Green (s)	9.0	40.2			27.2		29.0	29.0		7.0		42.7
Actuated g/C Ratio	0.10	0.45			0.30		0.32	0.32		0.08		0.47
v/c Ratio	0.99	0.65			0.86		0.93	0.88		1.11		0.77
Control Delay (s/veh)	89.6	23.9			37.9		56.9	37.7		127.8		18.5
Queue Delay	0.0	0.0			0.0		0.0	0.0		0.0		0.0
Total Delay (s/veh)	89.6	23.9			37.9		56.9	37.7		127.8		18.5
LOS	F	C			D		E	D		F		B
Approach Delay (s/veh)		49.4			37.9			44.1				51.5
Approach LOS		D			D			D				D

Intersection Summary

Area Type: Other  
 Cycle Length: 90  
 Actuated Cycle Length: 90  
 Natural Cycle: 90  
 Control Type: Actuated-Uncoordinated  
 Maximum v/c Ratio: 1.11  
 Intersection Signal Delay (s/veh): 45.6  
 Intersection LOS: D  
 Intersection Capacity Utilization 102.2%  
 ICU Level of Service G  
 Analysis Period (min) 15

Splits and Phases: 10: US 101 NB Off Ramp/Lakewood Drive & Old Redwood Highway

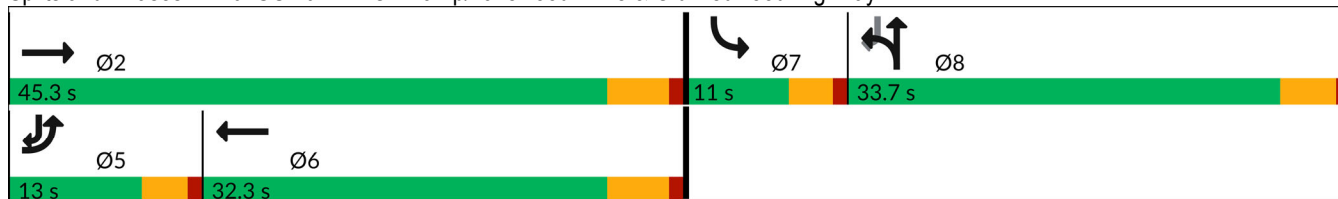

Lanes, Volumes, Timings  
 11: Old Redwood Highway & US 101 NB On Ramp

2028 Opening Year Alter. A Conditions

Timing Plan: P.M. Peak

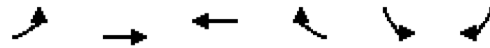

Lane Group	EBL	EBT	WBT	WBR	SBL	SBR
Lane Configurations	↶	↷	↶	↷		
Traffic Volume (vph)	121	760	1598	192	0	0
Future Volume (vph)	121	760	1598	192	0	0
Ideal Flow (vphp)	1900	1900	1900	1900	1900	1900
Storage Length (ft)	245			0	0	0
Storage Lanes	1			0	0	0
Taper Length (ft)	50				25	
Lane Util. Factor	1.00	0.95	0.95	0.95	1.00	1.00
Ped Bike Factor						
Frt			0.984			
Flt Protected	0.950					
Satd. Flow (prot)	1770	3539	3483	0	0	0
Flt Permitted	0.950					
Satd. Flow (perm)	1770	3539	3483	0	0	0
Link Speed (mph)		35	35		30	
Link Distance (ft)		531	226		299	
Travel Time (s)		10.3	4.4		6.8	
Confl. Peds. (#/hr)	17			17		
Confl. Bikes (#/hr)				8		
Peak Hour Factor	0.85	0.85	0.91	0.91	0.25	0.25
Adj. Flow (vph)	142	894	1756	211	0	0
Shared Lane Traffic (%)						
Lane Group Flow (vph)	142	894	1967	0	0	0
Enter Blocked Intersection	No	No	No	No	No	No
Lane Alignment	Left	Left	Left	Right	Left	Right
Median Width(ft)		12	12		0	
Link Offset(ft)		0	0		0	
Crosswalk Width(ft)		16	16		16	
Two way Left Turn Lane						
Headway Factor	1.00	1.00	1.00	1.00	1.00	1.00
Turning Speed (mph)	15			9	15	9
Sign Control		Free	Free		Free	

Intersection Summary	
Area Type:	Other
Control Type:	Unsignalized
Intersection Capacity Utilization	74.4%
Analysis Period (min)	15
	ICU Level of Service D



Lanes, Volumes, Timings

2028 Opening Year Alter. A Conditions

12: US 101 SB On Ramp/US 101 SB Off Ramp & Old Redwood Highway

Timing Plan: P.M. Peak



Lane Group	EBL	EBT	EBR	WBL	WBT	WBR	NBL	NBT	NBR	SBL	SBT	SBR
Lane Configurations		↑↑	↗	↖	↑↑					↖	↔	
Traffic Volume (vph)	0	609	434	434	1166	0	0	0	0	261	0	147
Future Volume (vph)	0	609	434	434	1166	0	0	0	0	261	0	147
Ideal Flow (vphpl)	1900	1900	1900	1900	1900	1900	1900	1900	1900	1900	1900	1900
Storage Length (ft)	0		0	250		0	0		0	420		0
Storage Lanes	0		1	0		0	0		0	1		0
Taper Length (ft)	25			165			25			75		
Lane Util. Factor	1.00	0.95	1.00	1.00	0.95	1.00	1.00	1.00	1.00	0.95	0.95	1.00
Ped Bike Factor			0.98	1.00								
Frt			0.850								0.887	
Flt Protected				0.950						0.950	0.988	
Satd. Flow (prot)	0	3539	1583	1770	3539	0	0	0	0	1681	1551	0
Flt Permitted				0.950						0.950	0.988	
Satd. Flow (perm)	0	3539	1558	1768	3539	0	0	0	0	1681	1551	0
Right Turn on Red			Yes			Yes			Yes			Yes
Satd. Flow (RTOR)			453								95	
Link Speed (mph)		35			35			30			30	
Link Distance (ft)		423			531			621			831	
Travel Time (s)		8.2			10.3			14.1			18.9	
Confl. Peds. (#/hr)	19		2	2		18						
Confl. Bikes (#/hr)			4			2						
Peak Hour Factor	0.94	0.94	0.94	0.89	0.89	0.89	0.25	0.25	0.25	0.83	0.83	0.83
Adj. Flow (vph)	0	648	462	488	1310	0	0	0	0	314	0	177
Shared Lane Traffic (%)										18%		
Lane Group Flow (vph)	0	648	462	488	1310	0	0	0	0	257	234	0
Enter Blocked Intersection	No	No	No	No	No	No	No	No	No	No	No	No
Lane Alignment	Left	Left	Right	Left	Left	Right	Left	Left	Right	Left	Left	Right
Median Width(ft)		24			24			12			12	
Link Offset(ft)		0			0			0			0	
Crosswalk Width(ft)		16			16			16			16	
Two way Left Turn Lane												
Headway Factor	1.00	1.00	1.00	1.00	1.00	1.00	1.00	1.00	1.00	1.00	1.00	1.00
Turning Speed (mph)	15		9	15		9	15		9	15		9
Number of Detectors		2	1	1	2					1	2	
Detector Template		Thru	Right	Left	Thru					Left	Thru	
Leading Detector (ft)		100	20	20	100					20	100	
Trailing Detector (ft)		0	0	0	0					0	0	
Detector 1 Position(ft)		0	0	0	0					0	0	
Detector 1 Size(ft)		6	20	20	6					20	6	
Detector 1 Type		Cl+Ex	Cl+Ex	Cl+Ex	Cl+Ex					Cl+Ex	Cl+Ex	
Detector 1 Channel												
Detector 1 Extend (s)		0.0	0.0	0.0	0.0					0.0	0.0	
Detector 1 Queue (s)		0.0	0.0	0.0	0.0					0.0	0.0	
Detector 1 Delay (s)		0.0	0.0	0.0	0.0					0.0	0.0	
Detector 2 Position(ft)		94			94							94
Detector 2 Size(ft)		6			6							6
Detector 2 Type		Cl+Ex			Cl+Ex							Cl+Ex
Detector 2 Channel												
Detector 2 Extend (s)		0.0			0.0							0.0

Lanes, Volumes, Timings

2028 Opening Year Alter. A Conditions

12: US 101 SB On Ramp/US 101 SB Off Ramp & Old Redwood Highway

Timing Plan: P.M. Peak



Lane Group	EBL	EBT	EBR	WBL	WBT	WBR	NBL	NBT	NBR	SBL	SBT	SBR
Turn Type		NA	Perm	Prot	NA					Perm	NA	
Protected Phases		6		5	2						8	
Permitted Phases			6							8		
Detector Phase		6	6	5	2					8	8	
Switch Phase												
Minimum Initial (s)		10.0	10.0	7.0	10.0					10.0	10.0	
Minimum Split (s)		32.1	32.1	11.0	38.1					14.7	14.7	
Total Split (s)		33.0	33.0	22.0	55.0					15.0	15.0	
Total Split (%)		47.1%	47.1%	31.4%	78.6%					21.4%	21.4%	
Maximum Green (s)		27.9	27.9	18.0	49.9					10.3	10.3	
Yellow Time (s)		4.1	4.1	3.0	4.1					3.7	3.7	
All-Red Time (s)		1.0	1.0	1.0	1.0					1.0	1.0	
Lost Time Adjust (s)		0.0	0.0	0.0	0.0					0.0	0.0	
Total Lost Time (s)		5.1	5.1	4.0	5.1					4.7	4.7	
Lead/Lag		Lag	Lag	Lead								
Lead-Lag Optimize?		Yes	Yes	Yes								
Vehicle Extension (s)		3.0	3.0	3.0	3.0					3.0	3.0	
Recall Mode		Max	Max	None	Max					None	None	
Walk Time (s)		7.0	7.0		7.0							
Flash Don't Walk (s)		20.0	20.0		25.0							
Pedestrian Calls (#/hr)		0	0		0							
Act Effct Green (s)		27.9	27.9	18.0	49.9					10.3	10.3	
Actuated g/C Ratio		0.40	0.40	0.26	0.71					0.15	0.15	
v/c Ratio		0.46	0.52	1.07	0.52					1.04	0.76	
Control Delay (s/veh)		16.8	4.1	91.7	5.5					101.9	34.9	
Queue Delay		0.0	0.0	0.0	0.0					0.0	0.0	
Total Delay (s/veh)		16.8	4.1	91.7	5.5					101.9	34.9	
LOS		B	A	F	A					F	C	
Approach Delay (s/veh)		11.5			28.9						69.9	
Approach LOS		B			C						E	

Intersection Summary





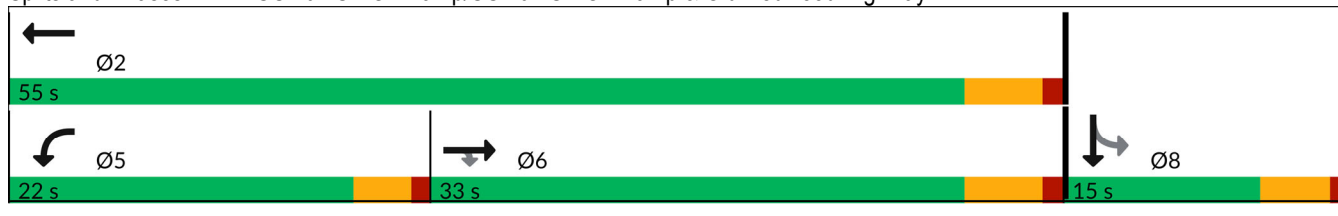

















Area Type: Other  
 Cycle Length: 70  
 Actuated Cycle Length: 70  
 Natural Cycle: 80  
 Control Type: Actuated-Uncoordinated  
 Maximum v/c Ratio: 1.07  
 Intersection Signal Delay (s/veh): 29.1  
 Intersection LOS: C  
 Intersection Capacity Utilization 74.4%  
 ICU Level of Service D  
 Analysis Period (min) 15

Splits and Phases: 12: US 101 SB On Ramp/US 101 SB Off Ramp & Old Redwood Highway



Lanes, Volumes, Timings  
1: Old Redwood Hwy & Shiloh Road

2028 Opening Year Alter. A Conditions  
Timing Plan: Saturday Midday Peak

												
Lane Group	EBL	EBT	EBR	WBL	WBT	WBR	NBL	NBT	NBR	SBL	SBT	SBR
Lane Configurations												
Traffic Volume (vph)	156	484	289	24	500	71	296	280	27	76	229	239
Future Volume (vph)	156	484	289	24	500	71	296	280	27	76	229	239
Ideal Flow (vphpl)	1900	1900	1900	1900	1900	1900	1900	1900	1900	1900	1900	1900
Storage Length (ft)	375		140	0		50	200		98	130		93
Storage Lanes	1		1	0		1	1		1	1		1
Taper Length (ft)	50			25			60			93		
Lane Util. Factor	1.00	1.00	1.00	1.00	1.00	1.00	1.00	1.00	1.00	1.00	1.00	1.00
Ped Bike Factor	1.00		0.98						0.98			0.97
Frt			0.850			0.850			0.850			0.850
Flt Protected	0.950				0.998		0.950			0.950		
Satd. Flow (prot)	1770	1863	1583	0	1859	1583	1770	1863	1583	1770	1863	1583
Flt Permitted	0.950				0.998		0.950			0.950		
Satd. Flow (perm)	1764	1863	1549	0	1859	1583	1770	1863	1550	1770	1863	1540
Right Turn on Red			Yes			Yes			Yes			Yes
Satd. Flow (RTOR)			136			113			81			177
Link Speed (mph)		40			40			45				40
Link Distance (ft)		1789			608			748				775
Travel Time (s)		30.5			10.4			11.3				13.2
Confl. Peds. (#/hr)	4											
Confl. Bikes (#/hr)			1						1			5
Peak Hour Factor	0.89	0.89	0.89	0.86	0.86	0.86	0.93	0.93	0.93	0.91	0.91	0.91
Adj. Flow (vph)	175	544	325	28	581	83	318	301	29	84	252	263
Shared Lane Traffic (%)												
Lane Group Flow (vph)	175	544	325	0	609	83	318	301	29	84	252	263
Enter Blocked Intersection	No	No	No	No	No	No	No	No	No	No	No	No
Lane Alignment	Left	Left	Right	Left	Left	Right	Left	Left	Right	Left	Left	Right
Median Width(ft)		12			12			12				12
Link Offset(ft)		0			0			0				0
Crosswalk Width(ft)		16			16			16				16
Two way Left Turn Lane												
Headway Factor	1.00	1.00	1.00	1.00	1.00	1.00	1.00	1.00	1.00	1.00	1.00	1.00
Turning Speed (mph)	15		9	15		9	15		9	15		9
Number of Detectors	1	2	1	1	2	1	1	2	1	1	2	1
Detector Template	Left	Thru	Right	Left	Thru	Right	Left	Thru	Right	Left	Thru	Right
Leading Detector (ft)	20	100	20	20	100	20	20	100	20	20	100	20
Trailing Detector (ft)	0	0	0	0	0	0	0	0	0	0	0	0
Detector 1 Position(ft)	0	0	0	0	0	0	0	0	0	0	0	0
Detector 1 Size(ft)	20	6	20	20	6	20	20	6	20	20	6	20
Detector 1 Type	Cl+Ex	Cl+Ex	Cl+Ex	Cl+Ex	Cl+Ex	Cl+Ex	Cl+Ex	Cl+Ex	Cl+Ex	Cl+Ex	Cl+Ex	Cl+Ex
Detector 1 Channel												
Detector 1 Extend (s)	0.0	0.0	0.0	0.0	0.0	0.0	0.0	0.0	0.0	0.0	0.0	0.0
Detector 1 Queue (s)	0.0	0.0	0.0	0.0	0.0	0.0	0.0	0.0	0.0	0.0	0.0	0.0
Detector 1 Delay (s)	0.0	0.0	0.0	0.0	0.0	0.0	0.0	0.0	0.0	0.0	0.0	0.0
Detector 2 Position(ft)		94			94			94				94
Detector 2 Size(ft)		6			6			6				6
Detector 2 Type		Cl+Ex			Cl+Ex			Cl+Ex				Cl+Ex
Detector 2 Channel												
Detector 2 Extend (s)		0.0			0.0			0.0				0.0

Lanes, Volumes, Timings  
1: Old Redwood Hwy & Shiloh Road

2028 Opening Year Alter. A Conditions  
Timing Plan: Saturday Midday Peak

Lane Group	EBL	EBT	EBR	WBL	WBT	WBR	NBL	NBT	NBR	SBL	SBT	SBR
Turn Type	Split	NA	Perm	Split	NA	Perm	Prot	NA	Perm	Prot	NA	Perm
Protected Phases	2	2		6	6		3	8		7	4	
Permitted Phases			2			6			8			4
Detector Phase	2	2	2	6	6	6	3	8	8	7	4	4
Switch Phase												
Minimum Initial (s)	5.0	5.0	5.0	5.0	5.0	5.0	5.0	5.0	5.0	5.0	5.0	5.0
Minimum Split (s)	34.5	34.5	34.5	42.5	42.5	42.5	9.0	46.5	46.5	9.0	39.5	39.5
Total Split (s)	35.0	35.0	35.0	42.5	42.5	42.5	18.0	48.0	48.0	9.5	39.5	39.5
Total Split (%)	25.9%	25.9%	25.9%	31.5%	31.5%	31.5%	13.3%	35.6%	35.6%	7.0%	29.3%	29.3%
Maximum Green (s)	30.5	30.5	30.5	38.0	38.0	38.0	14.0	43.5	43.5	5.5	35.0	35.0
Yellow Time (s)	3.5	3.5	3.5	3.5	3.5	3.5	3.5	3.5	3.5	3.5	3.5	3.5
All-Red Time (s)	1.0	1.0	1.0	1.0	1.0	1.0	0.5	1.0	1.0	0.5	1.0	1.0
Lost Time Adjust (s)	0.0	0.0	0.0		0.0	0.0	0.0	0.0	0.0	0.0	0.0	0.0
Total Lost Time (s)	4.5	4.5	4.5		4.5	4.5	4.0	4.5	4.5	4.0	4.5	4.5
Lead/Lag	Lead	Lead	Lead	Lag	Lag	Lag	Lead	Lag	Lag	Lead	Lag	Lag
Lead-Lag Optimize?	Yes	Yes	Yes	Yes	Yes	Yes	Yes	Yes	Yes	Yes	Yes	Yes
Vehicle Extension (s)	3.0	3.0	3.0	3.0	3.0	3.0	3.0	3.0	3.0	3.0	3.0	3.0
Recall Mode	None	None	None	None	None	None	None	None	None	None	None	None
Walk Time (s)	7.0	7.0	7.0	7.0	7.0	7.0		7.0	7.0		7.0	7.0
Flash Don't Walk (s)	23.0	23.0	23.0	31.0	31.0	31.0		35.0	35.0		28.0	28.0
Pedestrian Calls (#/hr)	0	0	0	0	0	0		0	0		0	0
Act Effct Green (s)	30.6	30.6	30.6		38.1	38.1	14.0	30.6	30.6	5.5	22.1	22.1
Actuated g/C Ratio	0.25	0.25	0.25		0.31	0.31	0.11	0.25	0.25	0.04	0.18	0.18
v/c Ratio	0.40	1.17	0.66		1.05	0.15	1.57	0.65	0.06	1.06	0.75	0.62
Control Delay (s/veh)	42.7	138.3	31.8		93.4	3.1	314.6	47.7	0.3	173.7	61.7	22.0
Queue Delay	0.0	0.0	0.0		0.0	0.0	0.0	0.0	0.0	0.0	0.0	0.0
Total Delay (s/veh)	42.7	138.3	31.8		93.4	3.1	314.6	47.7	0.3	173.7	61.7	22.0
LOS	D	F	C		F	A	F	D	A	F	E	C
Approach Delay (s/veh)		89.1			82.6			176.6			60.0	
Approach LOS		F			F			F			E	

Intersection Summary





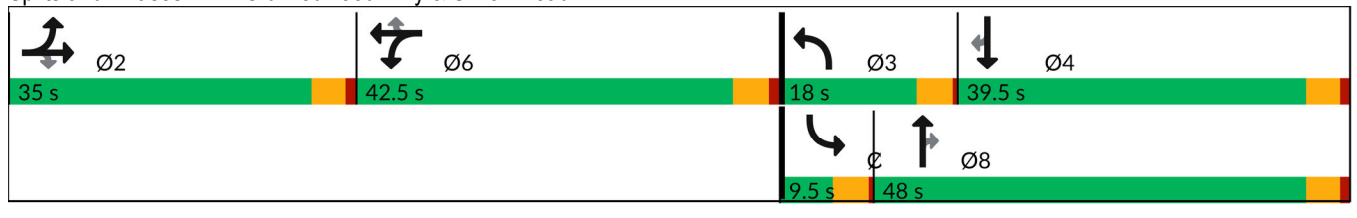















Area Type: Other  
 Cycle Length: 135  
 Actuated Cycle Length: 122.3  
 Natural Cycle: 145  
 Control Type: Actuated-Uncoordinated  
 Maximum v/c Ratio: 1.57  
 Intersection Signal Delay (s/veh): 100.7  
 Intersection LOS: F  
 Intersection Capacity Utilization 96.2%  
 ICU Level of Service F  
 Analysis Period (min) 15

Splits and Phases: 1: Old Redwood Hwy & Shiloh Road



Lanes, Volumes, Timings  
2: Shiloh Road & Hembree Ln

2028 Opening Year Alter. A Conditions  
Timing Plan: Saturday Midday Peak

												
Lane Group	EBL	EBT	EBR	WBL	WBT	WBR	NBL	NBT	NBR	SBL	SBT	SBR
Lane Configurations												
Traffic Volume (vph)	708	852	44	24	792	185	65	11	15	182	11	666
Future Volume (vph)	708	852	44	24	792	185	65	11	15	182	11	666
Ideal Flow (vphpl)	1900	1900	1900	1900	1900	1900	1900	1900	1900	1900	1900	1900
Storage Length (ft)	0		0	100		130	0		0	0		0
Storage Lanes	2		0	1		1	1		0	0		1
Taper Length (ft)	25			50			25			25		
Lane Util. Factor	0.97	1.00	1.00	1.00	0.95	0.95	1.00	1.00	1.00	1.00	1.00	1.00
Ped Bike Factor	1.00				1.00							
Frt		0.993			0.972			0.913				0.850
Flt Protected	0.950			0.950			0.950				0.955	
Satd. Flow (prot)	3433	1850	0	1770	3432	0	1770	1701	0	0	1779	1583
Flt Permitted	0.950			0.950			0.950				0.955	
Satd. Flow (perm)	3432	1850	0	1770	3432	0	1770	1701	0	0	1779	1583
Right Turn on Red			Yes			Yes			Yes			Yes
Satd. Flow (RTOR)		5			42			15				121
Link Speed (mph)		40			40			30				35
Link Distance (ft)		302			1789			216				381
Travel Time (s)		5.1			30.5			4.9				7.4
Confl. Peds. (#/hr)	1						1					
Peak Hour Factor	0.94	0.94	1.00	1.00	0.96	0.96	1.00	1.00	1.00	0.91	1.00	0.91
Adj. Flow (vph)	753	906	44	24	825	193	65	11	15	200	11	732
Shared Lane Traffic (%)												
Lane Group Flow (vph)	753	950	0	24	1018	0	65	26	0	0	211	732
Enter Blocked Intersection	No	No	No	No	No	No	No	No	No	No	No	No
Lane Alignment	Left	Left	Right	Left	Left	Right	Left	Left	Right	Left	Left	Right
Median Width(ft)		24			24			12				12
Link Offset(ft)		0			0			0				0
Crosswalk Width(ft)		16			16			16				16
Two way Left Turn Lane												
Headway Factor	1.00	1.00	1.00	1.00	1.00	1.00	1.00	1.00	1.00	1.00	1.00	1.00
Turning Speed (mph)	15		9	15		9	15		9	15		9
Number of Detectors	1	2		1	2		1	2		1	2	1
Detector Template	Left	Thru		Left	Thru		Left	Thru		Left	Thru	Right
Leading Detector (ft)	20	100		20	100		20	100		20	100	20
Trailing Detector (ft)	0	0		0	0		0	0		0	0	0
Detector 1 Position(ft)	0	0		0	0		0	0		0	0	0
Detector 1 Size(ft)	20	6		20	6		20	6		20	6	20
Detector 1 Type	Cl+Ex	Cl+Ex		Cl+Ex	Cl+Ex		Cl+Ex	Cl+Ex		Cl+Ex	Cl+Ex	Cl+Ex
Detector 1 Channel												
Detector 1 Extend (s)	0.0	0.0		0.0	0.0		0.0	0.0		0.0	0.0	0.0
Detector 1 Queue (s)	0.0	0.0		0.0	0.0		0.0	0.0		0.0	0.0	0.0
Detector 1 Delay (s)	0.0	0.0		0.0	0.0		0.0	0.0		0.0	0.0	0.0
Detector 2 Position(ft)		94			94			94				94
Detector 2 Size(ft)		6			6			6				6
Detector 2 Type		Cl+Ex			Cl+Ex			Cl+Ex				Cl+Ex
Detector 2 Channel												
Detector 2 Extend (s)		0.0			0.0			0.0				0.0
Turn Type	Prot	NA		Prot	NA		Split	NA		Split	NA	pt+ov

Lanes, Volumes, Timings  
2: Shiloh Road & Hembree Ln

2028 Opening Year Alter. A Conditions  
Timing Plan: Saturday Midday Peak

Lane Group	EBL	EBT	EBR	WBL	WBT	WBR	NBL	NBT	NBR	SBL	SBT	SBR
Protected Phases	5	2		1	6		8	8		4	4	4 5
Permitted Phases												
Detector Phase	5	2		1	6		8	8		4	4	4 5
Switch Phase												
Minimum Initial (s)	3.0	5.0		5.0	5.0		5.0	5.0		5.0	5.0	
Minimum Split (s)	7.5	9.5		9.5	43.5		9.5	9.5		9.5	9.5	
Total Split (s)	21.0	57.0		9.5	45.5		9.5	9.5		14.0	14.0	
Total Split (%)	23.3%	63.3%		10.6%	50.6%		10.6%	10.6%		15.6%	15.6%	
Maximum Green (s)	17.0	53.0		5.5	41.5		5.5	5.5		10.0	10.0	
Yellow Time (s)	3.0	3.0		3.0	3.0		3.0	3.0		3.0	3.0	
All-Red Time (s)	1.0	1.0		1.0	1.0		1.0	1.0		1.0	1.0	
Lost Time Adjust (s)	0.0	0.0		0.0	0.0		0.0	0.0			0.0	
Total Lost Time (s)	4.0	4.0		4.0	4.0		4.0	4.0			4.0	
Lead/Lag	Lead	Lag		Lead	Lag							
Lead-Lag Optimize?	Yes	Yes		Yes	Yes							
Vehicle Extension (s)	3.0	3.0		3.0	3.0		3.0	3.0		3.0	3.0	
Recall Mode	None	None		None	None		None	None		None	None	
Walk Time (s)					7.0							
Flash Don't Walk (s)					32.0							
Pedestrian Calls (#/hr)					1							
Act Effct Green (s)	17.5	49.2		5.7	30.9		5.7	5.7		10.3	28.8	
Actuated g/C Ratio	0.22	0.63		0.07	0.40		0.07	0.07		0.13	0.37	
v/c Ratio	0.98	0.81		0.19	0.74		0.51	0.19		0.91	1.11	
Control Delay (s/veh)	63.0	20.2		42.6	22.6		54.6	28.5		78.5	92.0	
Queue Delay	0.0	0.4		0.0	0.0		0.0	0.0		0.0	0.0	
Total Delay (s/veh)	63.0	20.5		42.6	22.6		54.6	28.5		78.5	92.0	
LOS	E	C		D	C		D	C		E	F	
Approach Delay (s/veh)		39.3			23.0			47.2			89.0	
Approach LOS		D			C			D			F	

Intersection Summary

Area Type:	Other
Cycle Length:	90
Actuated Cycle Length:	78.2
Natural Cycle:	110
Control Type:	Actuated-Uncoordinated
Maximum v/c Ratio:	1.11
Intersection Signal Delay (s/veh):	47.4
Intersection LOS:	D
Intersection Capacity Utilization:	83.4%
ICU Level of Service:	E
Analysis Period (min):	15

Splits and Phases: 2: Shiloh Road & Hembree Ln



Lanes, Volumes, Timings  
3: US 101 NB Off-Ramp & Shiloh Road

2028 Opening Year Alter. A Conditions  
Timing Plan: Saturday Midday Peak

	→	↘	↙	←	↖	↗
Lane Group	EBT	EBR	WBL	WBT	NBL	NBR
Lane Configurations	↑↑			↑	↘	↗
Traffic Volume (vph)	639	0	0	1115	401	954
Future Volume (vph)	639	0	0	1115	401	954
Ideal Flow (vphpl)	1900	1900	1900	1900	1900	1900
Storage Length (ft)		0	0		0	265
Storage Lanes		0	0		1	2
Taper Length (ft)			25		25	
Lane Util. Factor	0.95	1.00	1.00	1.00	1.00	0.88
Ped Bike Factor						
Frt						0.850
Flt Protected					0.950	
Satd. Flow (prot)	3539	0	0	1863	1770	2787
Flt Permitted					0.950	
Satd. Flow (perm)	3539	0	0	1863	1770	2787
Right Turn on Red		Yes				Yes
Satd. Flow (RTOR)						368
Link Speed (mph)	40			40	30	
Link Distance (ft)	186			371	769	
Travel Time (s)	3.2			6.3	17.5	
Confl. Bikes (#/hr)		1				
Peak Hour Factor	1.00	1.00	1.00	1.00	1.00	1.00
Adj. Flow (vph)	639	0	0	1115	401	954
Shared Lane Traffic (%)						
Lane Group Flow (vph)	639	0	0	1115	401	954
Enter Blocked Intersection	No	No	No	No	No	No
Lane Alignment	Left	Right	Left	Left	Left	Right
Median Width(ft)	0			0	12	
Link Offset(ft)	0			0	0	
Crosswalk Width(ft)	16			16	16	
Two way Left Turn Lane						
Headway Factor	1.00	1.00	1.00	1.00	1.00	1.00
Turning Speed (mph)		9	15		15	9
Number of Detectors	2			2	1	1
Detector Template	Thru			Thru	Left	Right
Leading Detector (ft)	100			100	20	20
Trailing Detector (ft)	0			0	0	0
Detector 1 Position(ft)	0			0	0	0
Detector 1 Size(ft)	6			6	20	20
Detector 1 Type	Cl+Ex			Cl+Ex	Cl+Ex	Cl+Ex
Detector 1 Channel						
Detector 1 Extend (s)	0.0			0.0	0.0	0.0
Detector 1 Queue (s)	0.0			0.0	0.0	0.0
Detector 1 Delay (s)	0.0			0.0	0.0	0.0
Detector 2 Position(ft)	94			94		
Detector 2 Size(ft)	6			6		
Detector 2 Type	Cl+Ex			Cl+Ex		
Detector 2 Channel						
Detector 2 Extend (s)	0.0			0.0		
Turn Type	NA			NA	Prot	Perm

Lanes, Volumes, Timings  
 3: US 101 NB Off-Ramp & Shiloh Road

2028 Opening Year Alter. A Conditions  
 Timing Plan: Saturday Midday Peak



Lane Group	EBT	EBR	WBL	WBT	NBL	NBR
Protected Phases	2			6	8	
Permitted Phases						8
Detector Phase	2			6	8	8
Switch Phase						
Minimum Initial (s)	5.0			5.0	5.0	5.0
Minimum Split (s)	9.5			9.5	9.5	9.5
Total Split (s)	45.0			45.0	35.0	35.0
Total Split (%)	56.3%			56.3%	43.8%	43.8%
Maximum Green (s)	40.5			40.5	30.5	30.5
Yellow Time (s)	3.5			3.5	3.5	3.5
All-Red Time (s)	1.0			1.0	1.0	1.0
Lost Time Adjust (s)	0.0			0.0	0.0	0.0
Total Lost Time (s)	4.5			4.5	4.5	4.5
Lead/Lag						
Lead-Lag Optimize?						
Vehicle Extension (s)	3.0			3.0	3.0	3.0
Recall Mode	None			None	None	None
Act Effct Green (s)	40.8			40.8	23.7	23.7
Actuated g/C Ratio	0.55			0.55	0.32	0.32
v/c Ratio	0.33			1.08	0.70	0.83
Control Delay (s/veh)	10.5			73.2	28.7	20.6
Queue Delay	0.0			0.0	0.0	0.0
Total Delay (s/veh)	10.5			73.2	28.7	20.6
LOS	B			E	C	C
Approach Delay (s/veh)	10.5			73.2	23.0	
Approach LOS	B			E	C	

Intersection Summary

Area Type:	Other
Cycle Length:	80
Actuated Cycle Length:	73.6
Natural Cycle:	90
Control Type:	Actuated-Uncoordinated
Maximum v/c Ratio:	1.08
Intersection Signal Delay (s/veh):	38.4
Intersection LOS:	D
Intersection Capacity Utilization:	152.0%
ICU Level of Service:	H
Analysis Period (min):	15

Splits and Phases: 3: US 101 NB Off-Ramp & Shiloh Road

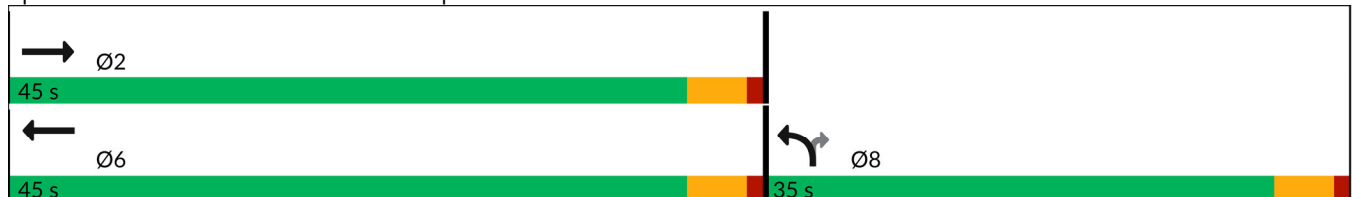



Lanes, Volumes, Timings  
4: Shiloh Road & US 101 SB Off-Ramp

2028 Opening Year Alter. A Conditions  
Timing Plan: Saturday Midday Peak

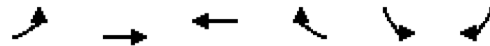

Lane Group	EBL	EBT	WBT	WBR	SBL	SBR
Lane Configurations		↑	↑		↓	↓
Traffic Volume (vph)	0	351	634	0	376	174
Future Volume (vph)	0	351	634	0	376	174
Ideal Flow (vphp)	1900	1900	1900	1900	1900	1900
Storage Length (ft)	0			0	0	275
Storage Lanes	0			0	1	1
Taper Length (ft)	25				25	
Lane Util. Factor	1.00	1.00	1.00	1.00	1.00	1.00
Ped Bike Factor						
Frt						0.850
Flt Protected					0.950	
Satd. Flow (prot)	0	1863	1863	0	1770	1583
Flt Permitted					0.950	
Satd. Flow (perm)	0	1863	1863	0	1770	1583
Right Turn on Red				Yes		Yes
Satd. Flow (RTOR)						256
Link Speed (mph)		40	40		30	
Link Distance (ft)		225	306		486	
Travel Time (s)		3.8	5.2		11.0	
Confl. Bikes (#/hr)				2		
Peak Hour Factor	0.96	0.96	0.96	0.96	0.68	0.68
Adj. Flow (vph)	0	366	660	0	553	256
Shared Lane Traffic (%)						
Lane Group Flow (vph)	0	366	660	0	553	256
Enter Blocked Intersection	No	No	No	No	No	No
Lane Alignment	Left	Left	Left	Right	Left	Right
Median Width(ft)		4	0		12	
Link Offset(ft)		0	0		0	
Crosswalk Width(ft)		16	16		16	
Two way Left Turn Lane						
Headway Factor	1.00	1.00	1.00	1.00	1.00	1.00
Turning Speed (mph)	15			9	15	9
Number of Detectors		2	2		1	1
Detector Template		Thru	Thru		Left	Right
Leading Detector (ft)		100	100		20	20
Trailing Detector (ft)		0	0		0	0
Detector 1 Position(ft)		0	0		0	0
Detector 1 Size(ft)		6	6		20	20
Detector 1 Type		Cl+Ex	Cl+Ex		Cl+Ex	Cl+Ex
Detector 1 Channel						
Detector 1 Extend (s)		0.0	0.0		0.0	0.0
Detector 1 Queue (s)		0.0	0.0		0.0	0.0
Detector 1 Delay (s)		0.0	0.0		0.0	0.0
Detector 2 Position(ft)		94	94			
Detector 2 Size(ft)		6	6			
Detector 2 Type		Cl+Ex	Cl+Ex			
Detector 2 Channel						
Detector 2 Extend (s)		0.0	0.0			
Turn Type		NA	NA		Perm	Perm

Lanes, Volumes, Timings  
4: Shiloh Road & US 101 SB Off-Ramp

2028 Opening Year Alter. A Conditions  
Timing Plan: Saturday Midday Peak

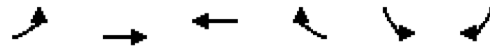

Lane Group	EBL	EBT	WBT	WBR	SBL	SBR
Protected Phases		2	6			
Permitted Phases					4	4
Detector Phase		2	6		4	4
Switch Phase						
Minimum Initial (s)		5.0	5.0		5.0	5.0
Minimum Split (s)		9.5	38.5		9.5	9.5
Total Split (s)		69.0	69.0		21.0	21.0
Total Split (%)		76.7%	76.7%		23.3%	23.3%
Maximum Green (s)		64.5	64.5		16.5	16.5
Yellow Time (s)		3.5	3.5		3.5	3.5
All-Red Time (s)		1.0	1.0		1.0	1.0
Lost Time Adjust (s)		0.0	0.0		0.0	0.0
Total Lost Time (s)		4.5	4.5		4.5	4.5
Lead/Lag						
Lead-Lag Optimize?						
Vehicle Extension (s)		3.0	3.0		3.0	3.0
Recall Mode		None	None		None	None
Walk Time (s)			7.0			
Flash Don't Walk (s)			27.0			
Pedestrian Calls (#/hr)			0			
Act Effct Green (s)		22.2	22.2		16.7	16.7
Actuated g/C Ratio		0.46	0.46		0.35	0.35
v/c Ratio		0.43	0.77		0.90	0.36
Control Delay (s/veh)		9.9	17.2		39.9	4.3
Queue Delay		0.0	0.0		0.0	0.0
Total Delay (s/veh)		9.9	17.2		39.9	4.3
LOS		A	B		D	A
Approach Delay (s/veh)		9.9	17.2		28.6	
Approach LOS		A	B		C	

Intersection Summary

Area Type:	Other
Cycle Length:	90
Actuated Cycle Length:	48.1
Natural Cycle:	65
Control Type:	Actuated-Uncoordinated
Maximum v/c Ratio:	0.90
Intersection Signal Delay (s/veh):	20.8
Intersection LOS:	C
Intersection Capacity Utilization:	133.9%
ICU Level of Service:	H
Analysis Period (min):	15

Splits and Phases: 4: Shiloh Road & US 101 SB Off-Ramp

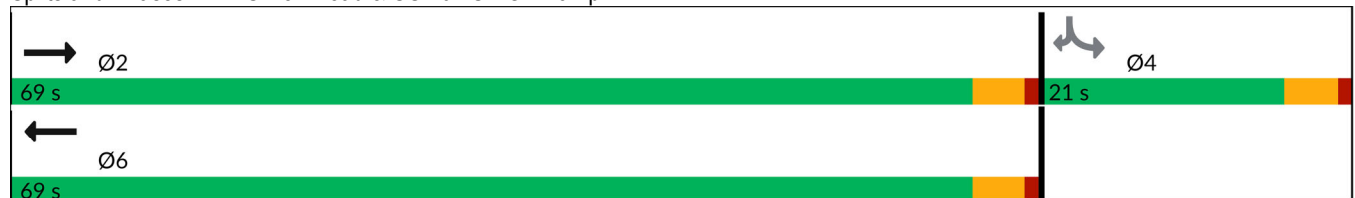

Lanes, Volumes, Timings  
5: Caletti Ave & Shiloh Road

2028 Opening Year Alter. A Conditions  
Timing Plan: Saturday Midday Peak



















Lane Group	EBT	EBR	WBL	WBT	NBL	NBR
Lane Configurations						
Traffic Volume (vph)	645	23	92	710	18	89
Future Volume (vph)	645	23	92	710	18	89
Ideal Flow (vphp)	1900	1900	1900	1900	1900	1900
Storage Length (ft)		0	68		0	0
Storage Lanes		0	1		1	1
Taper Length (ft)			50		25	
Lane Util. Factor	0.95	0.95	1.00	1.00	1.00	1.00
Ped Bike Factor						
Frt	0.995					0.850
Flt Protected			0.950		0.950	
Satd. Flow (prot)	3522	0	1770	1863	1770	1583
Flt Permitted			0.950		0.950	
Satd. Flow (perm)	3522	0	1770	1863	1770	1583
Link Speed (mph)	40			40	30	
Link Distance (ft)	1081			184	459	
Travel Time (s)	18.4			3.1	10.4	
Confl. Peds. (#/hr)					1	
Confl. Bikes (#/hr)		1				
Peak Hour Factor	0.92	0.92	0.87	0.87	0.78	0.78
Adj. Flow (vph)	701	25	106	816	23	114
Shared Lane Traffic (%)						
Lane Group Flow (vph)	726	0	106	816	23	114
Enter Blocked Intersection	No	No	No	No	No	No
Lane Alignment	Left	Right	Left	Left	Left	Right
Median Width(ft)	12			12	12	
Link Offset(ft)	0			0	0	
Crosswalk Width(ft)	16			16	16	
Two way Left Turn Lane						
Headway Factor	1.00	1.00	1.00	1.00	1.00	1.00
Turning Speed (mph)		9	15		15	9
Sign Control	Free			Free	Stop	

Intersection Summary

Area Type:	Other
Control Type:	Unsignalized
Intersection Capacity Utilization	47.4%
Analysis Period (min)	15
	ICU Level of Service A

Lanes, Volumes, Timings  
6: Conde Lane & Shiloh Road

2028 Opening Year Alter. A Conditions  
Timing Plan: Saturday Midday Peak

												
Lane Group	EBL	EBT	EBR	WBL	WBT	WBR	NBL	NBT	NBR	SBL	SBT	SBR
Lane Configurations												
Traffic Volume (vph)	33	435	1	10	482	232	1	0	7	224	0	32
Future Volume (vph)	33	435	1	10	482	232	1	0	7	224	0	32
Ideal Flow (vphpl)	1900	1900	1900	1900	1900	1900	1900	1900	1900	1900	1900	1900
Storage Length (ft)	90		0	127		0	0		0	0		40
Storage Lanes	1		0	1		0	0		0	0		1
Taper Length (ft)	70			40			25			25		
Lane Util. Factor	1.00	0.95	0.95	1.00	0.95	0.95	1.00	1.00	1.00	1.00	1.00	1.00
Ped Bike Factor					0.99							
Frt					0.951			0.884				0.850
Flt Protected	0.950			0.950				0.993			0.950	
Satd. Flow (prot)	1770	3539	0	1770	3342	0	0	1635	0	0	1770	1583
Flt Permitted	0.950			0.950				0.993			0.950	
Satd. Flow (perm)	1770	3539	0	1770	3342	0	0	1635	0	0	1770	1583
Right Turn on Red			Yes			Yes			Yes			No
Satd. Flow (RTOR)					82			102				
Link Speed (mph)		40			40			30				35
Link Distance (ft)		815			1081			418				522
Travel Time (s)		13.9			18.4			9.5				10.2
Confl. Bikes (#/hr)						2						
Peak Hour Factor	0.96	0.96	0.96	0.91	0.91	0.91	0.58	0.58	0.58	0.78	0.78	0.78
Adj. Flow (vph)	34	453	1	11	530	255	2	0	12	287	0	41
Shared Lane Traffic (%)												
Lane Group Flow (vph)	34	454	0	11	785	0	0	14	0	0	287	41
Enter Blocked Intersection	No	No	No	No	No	No	No	No	No	No	No	No
Lane Alignment	Left	Left	Right	Left	Left	Right	Left	Left	Right	Left	Left	Right
Median Width(ft)		12			12			0				0
Link Offset(ft)		0			0			0				0
Crosswalk Width(ft)		16			16			16				16
Two way Left Turn Lane												
Headway Factor	1.00	1.00	1.00	1.00	1.00	1.00	1.00	1.00	1.00	1.00	1.00	1.00
Turning Speed (mph)	15		9	15		9	15		9	15		9
Number of Detectors	1	2		1	2		1	2		1	1	1
Detector Template	Left	Thru		Left	Thru		Left	Thru		Left	Thru	Right
Leading Detector (ft)	20	100		20	100		20	100		20	30	20
Trailing Detector (ft)	0	0		0	0		0	0		0	0	0
Detector 1 Position(ft)	0	0		0	0		0	0		0	0	0
Detector 1 Size(ft)	20	6		20	6		20	6		20	30	20
Detector 1 Type	Cl+Ex	Cl+Ex		Cl+Ex	Cl+Ex		Cl+Ex	Cl+Ex		Cl+Ex	Cl+Ex	Cl+Ex
Detector 1 Channel												
Detector 1 Extend (s)	0.0	0.0		0.0	0.0		0.0	0.0		0.0	0.0	0.0
Detector 1 Queue (s)	0.0	0.0		0.0	0.0		0.0	0.0		0.0	0.0	0.0
Detector 1 Delay (s)	0.0	0.0		0.0	0.0		0.0	0.0		0.0	0.0	0.0
Detector 2 Position(ft)		94			94			94				
Detector 2 Size(ft)		6			6			6				
Detector 2 Type		Cl+Ex			Cl+Ex			Cl+Ex				
Detector 2 Channel												
Detector 2 Extend (s)		0.0			0.0			0.0				
Turn Type	Prot	NA		Prot	NA		Split	NA		Split	NA	custom

Lanes, Volumes, Timings  
6: Conde Lane & Shiloh Road

2028 Opening Year Alter. A Conditions  
Timing Plan: Saturday Midday Peak

Lane Group	EBL	EBT	EBR	WBL	WBT	WBR	NBL	NBT	NBR	SBL	SBT	SBR
Protected Phases	5	2		1	6		7	7		4	4	
Permitted Phases												6
Detector Phase	5	2		1	6		7	7		4	4	6
Switch Phase												
Minimum Initial (s)	8.0	8.0		8.0	8.0		10.0	10.0		11.0	11.0	8.0
Minimum Split (s)	12.5	46.5		12.5	12.5		37.5	37.5		15.5	15.5	12.5
Total Split (s)	13.0	46.5		12.5	45.0		37.5	37.5		15.5	15.5	45.0
Total Split (%)	11.6%	41.5%		11.2%	40.2%		33.5%	33.5%		13.8%	13.8%	40.2%
Maximum Green (s)	8.5	42.0		8.0	40.5		33.0	33.0		11.0	11.0	40.5
Yellow Time (s)	3.5	3.5		3.5	3.5		3.5	3.5		3.5	3.5	3.5
All-Red Time (s)	1.0	1.0		1.0	1.0		1.0	1.0		1.0	1.0	1.0
Lost Time Adjust (s)	0.0	0.0		0.0	0.0		0.0	0.0		0.0	0.0	0.0
Total Lost Time (s)	4.5	4.5		4.5	4.5		4.5	4.5		4.5	4.5	4.5
Lead/Lag	Lead	Lag		Lead	Lag							Lag
Lead-Lag Optimize?	Yes	Yes		Yes	Yes							Yes
Vehicle Extension (s)	3.0	3.0		3.0	3.0		3.0	3.0		3.0	3.0	3.0
Recall Mode	None	None		None	None		None	None		None	None	None
Walk Time (s)		7.0					7.0	7.0				
Flash Don't Walk (s)		35.0					26.0	26.0				
Pedestrian Calls (#/hr)		0					0	0				
Act Effct Green (s)	9.0	20.0		9.0	17.8			11.2			12.3	17.8
Actuated g/C Ratio	0.20	0.44		0.20	0.39			0.25			0.27	0.39
v/c Ratio	0.10	0.29		0.03	0.58			0.03			0.60	0.07
Control Delay (s/veh)	23.9	9.8		24.5	13.0			0.1			28.8	12.0
Queue Delay	0.0	0.0		0.0	0.0			0.0			0.0	0.0
Total Delay (s/veh)	23.9	9.8		24.5	13.0			0.1			28.8	12.0
LOS	C	A		C	B			A			C	B
Approach Delay (s/veh)		10.8			13.2			0.1			26.7	
Approach LOS		B			B			A			C	

Intersection Summary

Area Type:	Other
Cycle Length:	112
Actuated Cycle Length:	45.7
Natural Cycle:	115
Control Type:	Actuated-Uncoordinated
Maximum v/c Ratio:	0.60
Intersection Signal Delay (s/veh):	15.1
Intersection LOS:	B
Intersection Capacity Utilization:	54.0%
ICU Level of Service:	A
Analysis Period (min):	15

Splits and Phases: 6: Conde Lane & Shiloh Road

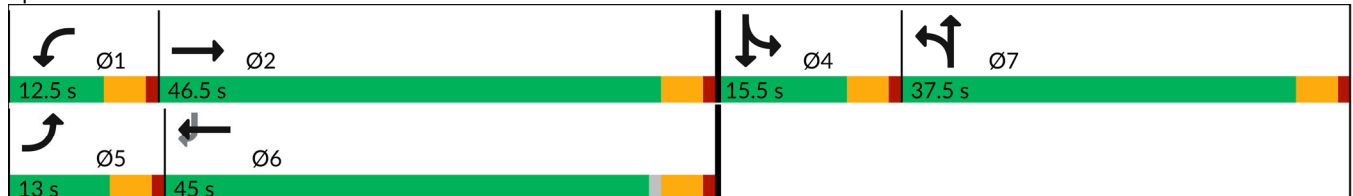

Lanes, Volumes, Timings  
7: Driveway 1/Gridley Drive & Shiloh Road



















2028 Opening Year Alter. A Conditions  
Timing Plan: Saturday Midday Peak

Lane Group	EBL	EBT	EBR	WBL	WBT	WBR	NBL	NBT	NBR	SBL	SBT	SBR
Lane Configurations												
Traffic Volume (vph)	23	463	112	0	460	0	116	0	0	0	0	20
Future Volume (vph)	23	463	112	0	460	0	116	0	0	0	0	20
Ideal Flow (vphpl)	1900	1900	1900	1900	1900	1900	1900	1900	1900	1900	1900	1900
Storage Length (ft)	0		150	0		0	0		0	0		0
Storage Lanes	0		1	0		0	1		0	0		0
Taper Length (ft)	25			25			25			25		
Lane Util. Factor	1.00	1.00	1.00	1.00	1.00	1.00	1.00	1.00	1.00	1.00	1.00	1.00
Ped Bike Factor												
Frt			0.850								0.865	
Flt Protected		0.998					0.950					
Satd. Flow (prot)	0	1859	1583	0	1863	0	1770	1863	0	0	1611	0
Flt Permitted		0.998					0.950					
Satd. Flow (perm)	0	1859	1583	0	1863	0	1770	1863	0	0	1611	0
Link Speed (mph)		40			40			30			30	
Link Distance (ft)		608			2146			248			715	
Travel Time (s)		10.4			36.6			5.6			16.3	
Confl. Peds. (#/hr)	1											
Confl. Bikes (#/hr)			1			3						
Peak Hour Factor	0.93	0.93	0.93	0.88	0.88	0.88	1.00	1.00	1.00	0.56	0.56	0.56
Adj. Flow (vph)	25	498	120	0	523	0	116	0	0	0	0	36
Shared Lane Traffic (%)												
Lane Group Flow (vph)	0	523	120	0	523	0	116	0	0	0	36	0
Enter Blocked Intersection	No	No	No	No	No	No	No	No	No	No	No	No
Lane Alignment	Left	Left	Right	Left	Left	Right	Left	Left	Right	Left	Left	Right
Median Width(ft)		0			0			12			12	
Link Offset(ft)		0			0			0			0	
Crosswalk Width(ft)		16			16			16			16	
Two way Left Turn Lane												
Headway Factor	1.00	1.00	1.00	1.00	1.00	1.00	1.00	1.00	1.00	1.00	1.00	1.00
Turning Speed (mph)	15		9	15		9	15		9	15		9
Sign Control		Free			Free			Stop			Stop	

Intersection Summary												
Area Type:	Other											
Control Type:	Unsignalized											
Intersection Capacity Utilization	62.9%						ICU Level of Service B					
Analysis Period (min)	15											

Lanes, Volumes, Timings  
8: Old Redwood Hwy & Driveway 2

2028 Opening Year Alter. A Conditions  
Timing Plan: Saturday Midday Peak

												
Lane Group	EBL	EBT	EBR	WBL	WBT	WBR	NBL	NBT	NBR	SBL	SBT	SBR
Lane Configurations												
Traffic Volume (vph)	1	0	2	68	0	109	1	459	66	105	389	5
Future Volume (vph)	1	0	2	68	0	109	1	459	66	105	389	5
Ideal Flow (vphp)	1900	1900	1900	1900	1900	1900	1900	1900	1900	1900	1900	1900
Storage Length (ft)	0		0	0		0	0		100	50		0
Storage Lanes	0		0	1		0	0		1	1		0
Taper Length (ft)	25			25			25			25		
Lane Util. Factor	1.00	1.00	1.00	1.00	1.00	1.00	1.00	1.00	1.00	1.00	1.00	1.00
Ped Bike Factor												
Frt		0.916			0.850				0.850		0.998	
Flt Protected		0.982		0.950						0.950		
Satd. Flow (prot)	0	1676	0	1770	1583	0	0	1863	1583	1770	1859	0
Flt Permitted		0.982		0.950						0.950		
Satd. Flow (perm)	0	1676	0	1770	1583	0	0	1863	1583	1770	1859	0
Link Speed (mph)		30			30			45			45	
Link Distance (ft)		98			385			520			748	
Travel Time (s)		2.2			8.8			7.9			11.3	
Confl. Peds. (#/hr)							1		4	4		1
Confl. Bikes (#/hr)									3			9
Peak Hour Factor	0.38	0.38	0.38	1.00	1.00	1.00	0.94	0.94	0.94	0.93	0.93	0.93
Adj. Flow (vph)	3	0	5	68	0	109	1	488	70	113	418	5
Shared Lane Traffic (%)												
Lane Group Flow (vph)	0	8	0	68	109	0	0	489	70	113	423	0
Enter Blocked Intersection	No	No	No	No	No	No	No	No	No	No	No	No
Lane Alignment	Left	Left	Right	Left	Left	Right	Left	Left	Right	Left	Left	Right
Median Width(ft)		12			12			12			12	
Link Offset(ft)		0			0			0			0	
Crosswalk Width(ft)		16			16			16			16	
Two way Left Turn Lane												
Headway Factor	1.00	1.00	1.00	1.00	1.00	1.00	1.00	1.00	1.00	1.00	1.00	1.00
Turning Speed (mph)	15		9	15		9	15		9	15		9
Sign Control		Stop			Stop			Free			Free	

**Intersection Summary**  
 Area Type: Other  
 Control Type: Unsignalized  
 Intersection Capacity Utilization 64.4% ICU Level of Service C  
 Analysis Period (min) 15

Lanes, Volumes, Timings  
9: Driveway 2 & Shiloh Road

2028 Opening Year Alter. A Conditions

Timing Plan: Saturday Midday Peak

	→	↘	↙	←	↖	↗
Lane Group	EBT	EBR	WBL	WBT	NBL	NBR
Lane Configurations	↑	↗		↖	↘	↗
Traffic Volume (vph)	105	342	32	98	355	34
Future Volume (vph)	105	342	32	98	355	34
Ideal Flow (vphp)	1900	1900	1900	1900	1900	1900
Storage Length (ft)		200	0		0	0
Storage Lanes		1	0		1	1
Taper Length (ft)			25		25	
Lane Util. Factor	1.00	1.00	1.00	1.00	1.00	1.00
Ped Bike Factor						
Frt		0.850				0.850
Flt Protected				0.988	0.950	
Satd. Flow (prot)	1863	1583	0	1840	1770	1583
Flt Permitted				0.988	0.950	
Satd. Flow (perm)	1863	1583	0	1840	1770	1583
Link Speed (mph)	40			40	30	
Link Distance (ft)	2146			134	402	
Travel Time (s)	36.6			2.3	9.1	
Confl. Peds. (#/hr)		1				
Peak Hour Factor	0.88	0.88	0.80	0.80	1.00	1.00
Adj. Flow (vph)	119	389	40	123	355	34
Shared Lane Traffic (%)						
Lane Group Flow (vph)	119	389	0	163	355	34
Enter Blocked Intersection	No	No	No	No	No	No
Lane Alignment	Left	Right	Left	Left	Left	Right
Median Width(ft)	0			0	12	
Link Offset(ft)	0			0	0	
Crosswalk Width(ft)	16			16	16	
Two way Left Turn Lane						
Headway Factor	1.00	1.00	1.00	1.00	1.00	1.00
Turning Speed (mph)		9	15		15	9
Sign Control	Free			Free	Stop	
<b>Intersection Summary</b>						
Area Type:	Other					
Control Type:	Unsignalized					
Intersection Capacity Utilization	39.9%			ICU Level of Service A		
Analysis Period (min)	15					



Lanes, Volumes, Timings

2028 Opening Year Alter. A Conditions

10: US 101 NB Off Ramp/Lakewood Drive & Old Redwood Highway Timing Plan: Saturday Midday Peak



Lane Group	EBL	EBT	EBR	WBL	WBT	WBR	NBL	NBT	NBR	SBL	SBT	SBR
Lane Configurations												
Traffic Volume (vph)	287	379	0	0	570	276	320	303	142	244	0	700
Future Volume (vph)	287	379	0	0	570	276	320	303	142	244	0	700
Ideal Flow (vphpl)	1900	1900	1900	1900	1900	1900	1900	1900	1900	1900	1900	1900
Storage Length (ft)	155		0	0		0	270		150	120		0
Storage Lanes	1		0	0		0	1		1	1		1
Taper Length (ft)	50			25			165			75		
Lane Util. Factor	0.97	1.00	1.00	1.00	0.95	0.95	0.91	0.91	0.95	0.97	1.00	1.00
Ped Bike Factor	1.00				0.99			1.00		1.00		
Flt					0.951			0.958				0.850
Flt Protected	0.950						0.950	0.994		0.950		
Satd. Flow (prot)	3433	1863	0	0	3348	0	1610	3217	0	3433	0	1583
Flt Permitted	0.950						0.950	0.994		0.950		
Satd. Flow (perm)	3430	1863	0	0	3348	0	1610	3217	0	3430	0	1583
Right Turn on Red			Yes			Yes			Yes			Yes
Satd. Flow (RTOR)					95			61				272
Link Speed (mph)		35			35			30				30
Link Distance (ft)		226			617			716				478
Travel Time (s)		4.4			12.0			16.3				10.9
Confl. Peds. (#/hr)	2		1	1		2			1	1		
Confl. Bikes (#/hr)			10			3						
Peak Hour Factor	0.95	0.95	0.95	0.89	0.89	0.89	0.98	0.98	0.98	0.88	0.88	0.88
Adj. Flow (vph)	302	399	0	0	640	310	327	309	145	277	0	795
Shared Lane Traffic (%)							20%					
Lane Group Flow (vph)	302	399	0	0	950	0	262	519	0	277	0	795
Enter Blocked Intersection	No	No	No	No	No	No	No	No	No	No	No	No
Lane Alignment	Left	Left	Right	Left	Left	Right	Left	Left	Right	Left	Left	Right
Median Width(ft)		24			24			24				24
Link Offset(ft)		0			0			0				0
Crosswalk Width(ft)		16			16			16				16
Two way Left Turn Lane												
Headway Factor	1.00	1.00	1.00	1.00	1.00	1.00	1.00	1.00	1.00	1.00	1.00	1.00
Turning Speed (mph)	15		9	15		9	15		9	15		9
Number of Detectors	1	2			2		1	2		1		1
Detector Template	Left	Thru			Thru		Left	Thru		Left		Right
Leading Detector (ft)	20	100			100		20	100		20		20
Trailing Detector (ft)	0	0			0		0	0		0		0
Detector 1 Position(ft)	0	0			0		0	0		0		0
Detector 1 Size(ft)	20	6			6		20	6		20		20
Detector 1 Type	Cl+Ex	Cl+Ex			Cl+Ex		Cl+Ex	Cl+Ex		Cl+Ex		Cl+Ex
Detector 1 Channel												
Detector 1 Extend (s)	0.0	0.0			0.0		0.0	0.0		0.0		0.0
Detector 1 Queue (s)	0.0	0.0			0.0		0.0	0.0		0.0		0.0
Detector 1 Delay (s)	0.0	0.0			0.0		0.0	0.0		0.0		0.0
Detector 2 Position(ft)		94			94			94				
Detector 2 Size(ft)		6			6			6				
Detector 2 Type		Cl+Ex			Cl+Ex			Cl+Ex				
Detector 2 Channel												
Detector 2 Extend (s)		0.0			0.0			0.0				

Lanes, Volumes, Timings

2028 Opening Year Alter. A Conditions

10: US 101 NB Off Ramp/Lakewood Drive & Old Redwood Highway Timing Plan: Saturday Midday Peak



Lane Group	EBL	EBT	EBR	WBL	WBT	WBR	NBL	NBT	NBR	SBL	SBT	SBR
Turn Type	Prot	NA			NA		Split	NA		Prot		pm+ov
Protected Phases	5	2			6		8	8		7		5
Permitted Phases												5 8
Detector Phase	5	2			6		8	8		7		5
Switch Phase												
Minimum Initial (s)	7.0	10.0			10.0		10.0	10.0		7.0		7.0
Minimum Split (s)	11.5	32.1			32.1		33.7	33.7		11.5		11.5
Total Split (s)	12.0	45.3			33.3		33.7	33.7		11.5		12.0
Total Split (%)	13.3%	50.1%			36.8%		37.2%	37.2%		12.7%		13.3%
Maximum Green (s)	7.5	40.8			28.8		29.2	29.2		7.0		7.5
Yellow Time (s)	3.5	3.5			3.5		3.5	3.5		3.5		3.5
All-Red Time (s)	1.0	1.0			1.0		1.0	1.0		1.0		1.0
Lost Time Adjust (s)	0.0	0.0			0.0		0.0	0.0		0.0		0.0
Total Lost Time (s)	4.5	4.5			4.5		4.5	4.5		4.5		4.5
Lead/Lag	Lead				Lag		Lag	Lag		Lead		Lead
Lead-Lag Optimize?	Yes				Yes		Yes	Yes		Yes		Yes
Vehicle Extension (s)	3.0	3.0			3.0		3.0	3.0		3.0		3.0
Recall Mode	None	Max			Max		None	None		None		None
Walk Time (s)		7.0			7.0		7.0	7.0				
Flash Don't Walk (s)		20.0			17.0		22.0	22.0				
Pedestrian Calls (#/hr)		0			0		0	0				
Act Effct Green (s)	7.5	41.0			29.0		20.3	20.3		7.0		32.4
Actuated g/C Ratio	0.09	0.50			0.35		0.25	0.25		0.09		0.40
v/c Ratio	0.96	0.43			0.76		0.66	0.61		0.94		1.01
Control Delay (s/veh)	81.7	16.1			27.1		35.6	26.8		80.3		51.1
Queue Delay	0.0	0.0			0.0		0.0	0.0		0.0		0.0
Total Delay (s/veh)	81.7	16.1			27.1		35.6	26.8		80.3		51.1
LOS	F	B			C		D	C		F		D
Approach Delay (s/veh)		44.4			27.1			29.8				58.7
Approach LOS		D			C			C				E

Intersection Summary

Area Type: Other  
 Cycle Length: 90.5  
 Actuated Cycle Length: 82  
 Natural Cycle: 90  
 Control Type: Actuated-Uncoordinated  
 Maximum v/c Ratio: 1.01  
 Intersection Signal Delay (s/veh): 40.8  
 Intersection LOS: D  
 Intersection Capacity Utilization 94.4%  
 ICU Level of Service F  
 Analysis Period (min) 15

Splits and Phases: 10: US 101 NB Off Ramp/Lakewood Drive & Old Redwood Highway

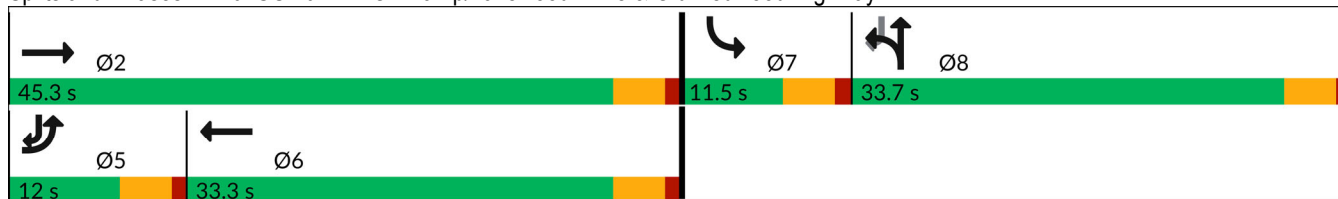

Lanes, Volumes, Timings  
 11: Old Redwood Highway & US 101 NB On Ramp

2028 Opening Year Alter. A Conditions  
 Timing Plan: Saturday Midday Peak

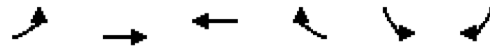

Lane Group	EBL	EBT	WBT	WBR	SBL	SBR
Lane Configurations	↶	↷↷	↶↷			
Traffic Volume (vph)	87	671	1310	215	0	0
Future Volume (vph)	87	671	1310	215	0	0
Ideal Flow (vphp)	1900	1900	1900	1900	1900	1900
Storage Length (ft)	245			0	0	0
Storage Lanes	1			0	0	0
Taper Length (ft)	50				25	
Lane Util. Factor	1.00	0.95	0.95	0.95	1.00	1.00
Ped Bike Factor						
Frt			0.979			
Flt Protected	0.950					
Satd. Flow (prot)	1770	3539	3465	0	0	0
Flt Permitted	0.950					
Satd. Flow (perm)	1770	3539	3465	0	0	0
Link Speed (mph)		35	35		30	
Link Distance (ft)		531	226		299	
Travel Time (s)		10.3	4.4		6.8	
Confl. Peds. (#/hr)	8			8		
Confl. Bikes (#/hr)				4		
Peak Hour Factor	0.96	0.96	0.92	0.92	0.25	0.25
Adj. Flow (vph)	91	699	1424	234	0	0
Shared Lane Traffic (%)						
Lane Group Flow (vph)	91	699	1658	0	0	0
Enter Blocked Intersection	No	No	No	No	No	No
Lane Alignment	Left	Left	Left	Right	Left	Right
Median Width(ft)		12	12		0	
Link Offset(ft)		0	0		0	
Crosswalk Width(ft)		16	16		16	
Two way Left Turn Lane						
Headway Factor	1.00	1.00	1.00	1.00	1.00	1.00
Turning Speed (mph)	15			9	15	9
Sign Control		Free	Free		Free	

Intersection Summary	
Area Type:	Other
Control Type:	Unsignalized
Intersection Capacity Utilization	73.1%
Analysis Period (min)	15
	ICU Level of Service D

Lanes, Volumes, Timings

2028 Opening Year Alter. A Conditions

12: US 101 SB On Ramp/US 101 SB Off Ramp & Old Redwood Highway Timing Plan: Saturday Midday Peak



Lane Group	EBL	EBT	EBR	WBL	WBT	WBR	NBL	NBT	NBR	SBL	SBT	SBR
Lane Configurations		↑↑	↗	↖	↑↑					↘	↕	
Traffic Volume (vph)	0	550	419	487	818	0	0	0	0	217	1	87
Future Volume (vph)	0	550	419	487	818	0	0	0	0	217	1	87
Ideal Flow (vphpl)	1900	1900	1900	1900	1900	1900	1900	1900	1900	1900	1900	1900
Storage Length (ft)	0		0	250		0	0		0	420		0
Storage Lanes	0		1	0		0	0		0	1		0
Taper Length (ft)	25			165			25			75		
Lane Util. Factor	1.00	0.95	1.00	1.00	0.95	1.00	1.00	1.00	1.00	0.95	0.95	1.00
Ped Bike Factor			0.98	1.00								
Frt			0.850								0.911	
Flt Protected				0.950						0.950	0.980	
Satd. Flow (prot)	0	3539	1583	1770	3539	0	0	0	0	1681	1580	0
Flt Permitted				0.950						0.950	0.980	
Satd. Flow (perm)	0	3539	1553	1768	3539	0	0	0	0	1681	1580	0
Right Turn on Red			Yes			Yes			Yes			Yes
Satd. Flow (RTOR)			432								89	
Link Speed (mph)		35			35			30			30	
Link Distance (ft)		423			531			621			831	
Travel Time (s)		8.2			10.3			14.1			18.9	
Confl. Peds. (#/hr)	11		2	2		11						
Confl. Bikes (#/hr)			10			2						
Peak Hour Factor	0.97	0.97	0.97	0.96	0.96	0.96	0.25	0.25	0.25	0.72	0.72	0.72
Adj. Flow (vph)	0	567	432	507	852	0	0	0	0	301	1	121
Shared Lane Traffic (%)										27%		
Lane Group Flow (vph)	0	567	432	507	852	0	0	0	0	220	203	0
Enter Blocked Intersection	No	No	No	No	No	No	No	No	No	No	No	No
Lane Alignment	Left	Left	Right	Left	Left	Right	Left	Left	Right	Left	Left	Right
Median Width(ft)		24			24			12			12	
Link Offset(ft)		0			0			0			0	
Crosswalk Width(ft)		16			16			16			16	
Two way Left Turn Lane												
Headway Factor	1.00	1.00	1.00	1.00	1.00	1.00	1.00	1.00	1.00	1.00	1.00	1.00
Turning Speed (mph)	15		9	15		9	15		9	15		9
Number of Detectors		2	1	1	2					1	2	
Detector Template		Thru	Right	Left	Thru					Left	Thru	
Leading Detector (ft)		100	20	20	100					20	100	
Trailing Detector (ft)		0	0	0	0					0	0	
Detector 1 Position(ft)		0	0	0	0					0	0	
Detector 1 Size(ft)		6	20	20	6					20	6	
Detector 1 Type		Cl+Ex	Cl+Ex	Cl+Ex	Cl+Ex					Cl+Ex	Cl+Ex	
Detector 1 Channel												
Detector 1 Extend (s)		0.0	0.0	0.0	0.0					0.0	0.0	
Detector 1 Queue (s)		0.0	0.0	0.0	0.0					0.0	0.0	
Detector 1 Delay (s)		0.0	0.0	0.0	0.0					0.0	0.0	
Detector 2 Position(ft)		94			94							94
Detector 2 Size(ft)		6			6							6
Detector 2 Type		Cl+Ex			Cl+Ex							Cl+Ex
Detector 2 Channel												
Detector 2 Extend (s)		0.0			0.0							0.0

Lanes, Volumes, Timings

2028 Opening Year Alter. A Conditions

12: US 101 SB On Ramp/US 101 SB Off Ramp & Old Redwood Highway Timing Plan: Saturday Midday Peak



Lane Group	EBL	EBT	EBR	WBL	WBT	WBR	NBL	NBT	NBR	SBL	SBT	SBR
Turn Type		NA	Perm	Prot	NA					Perm	NA	
Protected Phases		6		5	2						8	
Permitted Phases			6							8		
Detector Phase		6	6	5	2					8	8	
Switch Phase												
Minimum Initial (s)		10.0	10.0	7.0	10.0					10.0	10.0	
Minimum Split (s)		32.1	32.1	11.5	38.1					14.7	14.7	
Total Split (s)		32.3	32.3	23.0	55.3					14.7	14.7	
Total Split (%)		46.1%	46.1%	32.9%	79.0%					21.0%	21.0%	
Maximum Green (s)		27.8	27.8	18.5	50.8					10.2	10.2	
Yellow Time (s)		3.5	3.5	3.5	3.5					3.5	3.5	
All-Red Time (s)		1.0	1.0	1.0	1.0					1.0	1.0	
Lost Time Adjust (s)		0.0	0.0	0.0	0.0					0.0	0.0	
Total Lost Time (s)		4.5	4.5	4.5	4.5					4.5	4.5	
Lead/Lag		Lag	Lag	Lead								
Lead-Lag Optimize?		Yes	Yes	Yes								
Vehicle Extension (s)		3.0	3.0	3.0	3.0					3.0	3.0	
Recall Mode		Max	Max	None	Max					None	None	
Walk Time (s)		7.0	7.0		7.0							
Flash Don't Walk (s)		20.0	20.0		25.0							
Pedestrian Calls (#/hr)		0	0		0							
Act Effct Green (s)		27.8	27.8	18.5	50.8					10.2	10.2	
Actuated g/C Ratio		0.40	0.40	0.26	0.73					0.15	0.15	
v/c Ratio		0.40	0.49	1.09	0.33					0.90	0.66	
Control Delay (s/veh)		16.2	3.8	95.1	3.9					70.1	28.3	
Queue Delay		0.0	0.0	0.0	0.0					0.0	0.0	
Total Delay (s/veh)		16.2	3.8	95.1	3.9					70.1	28.3	
LOS		B	A	F	A					E	C	
Approach Delay (s/veh)		10.9			37.9						50.1	
Approach LOS		B			D						D	

Intersection Summary

Area Type: Other  
 Cycle Length: 70  
 Actuated Cycle Length: 70  
 Natural Cycle: 80  
 Control Type: Actuated-Uncoordinated  
 Maximum v/c Ratio: 1.09  
 Intersection Signal Delay (s/veh): 30.0 Intersection LOS: C  
 Intersection Capacity Utilization 73.1% ICU Level of Service D  
 Analysis Period (min) 15



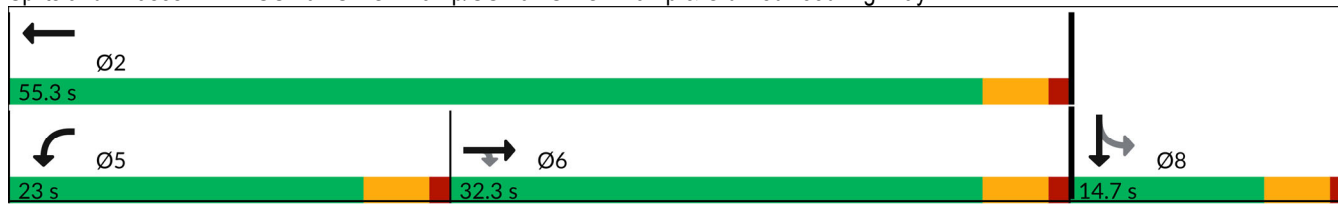



















Splits and Phases: 12: US 101 SB On Ramp/US 101 SB Off Ramp & Old Redwood Highway



Appendix H – Opening Year 2028 plus Alternative B Project  
Conditions Intersection Level of Service Worksheets

HCM 6th Signalized Intersection Summary  
 1: Old Redwood Hwy & Shiloh Road

























2028 Opening Year Alter. B Project Conditions  
 Timing Plan: A.M. PEAK

												
Movement	EBL	EBT	EBR	WBL	WBT	WBR	NBL	NBT	NBR	SBL	SBT	SBR
Lane Configurations												
Traffic Volume (veh/h)	137	290	135	25	180	28	120	146	39	37	269	208
Future Volume (veh/h)	137	290	135	25	180	28	120	146	39	37	269	208
Initial Q (Qb), veh	0	0	0	0	0	0	0	0	0	0	0	0
Ped-Bike Adj(A_pbT)	1.00		1.00	1.00		1.00	1.00		1.00	1.00		0.98
Parking Bus, Adj	1.00	1.00	1.00	1.00	1.00	1.00	1.00	1.00	1.00	1.00	1.00	1.00
Work Zone On Approach		No			No			No			No	
Adj Sat Flow, veh/h/ln	1870	1870	1870	1870	1870	1870	1870	1870	1870	1870	1870	1870
Adj Flow Rate, veh/h	169	358	167	28	202	31	129	157	42	44	316	245
Peak Hour Factor	0.81	0.81	0.81	0.89	0.89	0.89	0.93	0.93	0.93	0.85	0.85	0.85
Percent Heavy Veh, %	2	2	2	2	2	2	2	2	2	2	2	2
Cap, veh/h	445	467	396	38	272	264	183	474	402	134	423	351
Arrive On Green	0.25	0.25	0.25	0.17	0.17	0.17	0.10	0.25	0.25	0.08	0.23	0.23
Sat Flow, veh/h	1781	1870	1585	226	1633	1585	1781	1870	1585	1781	1870	1551
Grp Volume(v), veh/h	169	358	167	230	0	31	129	157	42	44	316	245
Grp Sat Flow(s),veh/h/ln	1781	1870	1585	1859	0	1585	1781	1870	1585	1781	1870	1551
Q Serve(g_s), s	5.2	11.8	5.9	7.8	0.0	1.1	4.7	4.6	1.4	1.6	10.5	9.7
Cycle Q Clear(g_c), s	5.2	11.8	5.9	7.8	0.0	1.1	4.7	4.6	1.4	1.6	10.5	9.7
Prop In Lane	1.00		1.00	0.12		1.00	1.00		1.00	1.00		1.00
Lane Grp Cap(c), veh/h	445	467	396	309	0	264	183	474	402	134	423	351
V/C Ratio(X)	0.38	0.77	0.42	0.74	0.00	0.12	0.71	0.33	0.10	0.33	0.75	0.70
Avail Cap(c_a), veh/h	815	856	726	1060	0	904	388	1221	1035	160	982	815
HCM Platoon Ratio	1.00	1.00	1.00	1.00	1.00	1.00	1.00	1.00	1.00	1.00	1.00	1.00
Upstream Filter(I)	1.00	1.00	1.00	1.00	0.00	1.00	1.00	1.00	1.00	1.00	1.00	1.00
Uniform Delay (d), s/veh	20.7	23.2	21.0	26.4	0.0	23.6	28.9	20.3	19.1	29.2	24.0	23.7
Incr Delay (d2), s/veh	0.5	2.7	0.7	3.5	0.0	0.2	4.9	0.4	0.1	1.4	2.7	2.5
Initial Q Delay(d3),s/veh	0.0	0.0	0.0	0.0	0.0	0.0	0.0	0.0	0.0	0.0	0.0	0.0
%ile BackOfQ(50%),veh/ln	2.0	5.0	2.0	3.5	0.0	0.4	2.1	1.8	0.5	0.7	4.5	3.4
Unsig. Movement Delay, s/veh												
LnGrp Delay(d),s/veh	21.2	25.8	21.7	30.0	0.0	23.8	33.9	20.7	19.2	30.6	26.7	26.2
LnGrp LOS	C	C	C	C	A	C	C	C	B	C	C	C
Approach Vol, veh/h		694			261			328			605	
Approach Delay, s/veh		23.7			29.2			25.7			26.8	
Approach LOS		C			C			C			C	
Timer - Assigned Phs		2	3	4		6	7	8				
Phs Duration (G+Y+Rc), s		21.2	10.3	19.6		15.6	8.5	21.4				
Change Period (Y+Rc), s		4.5	3.5	4.5		4.5	3.5	4.5				
Max Green Setting (Gmax), s		30.5	14.5	35.0		38.0	6.0	43.5				
Max Q Clear Time (g_c+I1), s		13.8	6.7	12.5		9.8	3.6	6.6				
Green Ext Time (p_c), s		2.8	0.2	2.6		1.3	0.0	0.9				
<b>Intersection Summary</b>												
HCM 6th Ctrl Delay				25.8								
HCM 6th LOS				C								

HCM 6th Signalized Intersection Summary  
2: Shiloh Road & Hembree Ln

2028 Opening Year Alter. B Project Conditions

Timing Plan: A.M. PEAK

												
Movement	EBL	EBT	EBR	WBL	WBT	WBR	NBL	NBT	NBR	SBL	SBT	SBR
Lane Configurations	 			 	 						 	
Traffic Volume (veh/h)	347	511	38	19	466	82	39	7	11	81	9	413
Future Volume (veh/h)	347	511	38	19	466	82	39	7	11	81	9	413
Initial Q (Qb), veh	0	0	0	0	0	0	0	0	0	0	0	0
Ped-Bike Adj(A_pbT)	1.00		1.00	1.00		1.00	1.00		1.00	1.00		1.00
Parking Bus, Adj	1.00	1.00	1.00	1.00	1.00	1.00	1.00	1.00	1.00	1.00	1.00	1.00
Work Zone On Approach		No			No			No			No	
Adj Sat Flow, veh/h/ln	1870	1870	1870	1870	1870	1870	1870	1870	1870	1870	1870	1870
Adj Flow Rate, veh/h	394	581	38	19	480	85	39	7	11	86	9	439
Peak Hour Factor	0.88	0.88	1.00	1.00	0.97	0.97	1.00	1.00	1.00	0.94	1.00	0.94
Percent Heavy Veh, %	2	2	2	2	2	2	2	2	2	2	2	2
Cap, veh/h	570	724	47	41	831	146	96	35	56	315	33	570
Arrive On Green	0.16	0.42	0.42	0.02	0.28	0.28	0.05	0.05	0.05	0.19	0.19	0.19
Sat Flow, veh/h	3456	1736	114	1781	3020	532	1781	655	1030	1620	170	1585
Grp Volume(v), veh/h	394	0	619	19	281	284	39	0	18	95	0	439
Grp Sat Flow(s),veh/h/ln	1728	0	1850	1781	1777	1775	1781	0	1685	1789	0	1585
Q Serve(g_s), s	5.5	0.0	15.1	0.5	7.0	7.1	1.1	0.0	0.5	2.3	0.0	10.0
Cycle Q Clear(g_c), s	5.5	0.0	15.1	0.5	7.0	7.1	1.1	0.0	0.5	2.3	0.0	10.0
Prop In Lane	1.00		0.06	1.00		0.30	1.00		0.61	0.91		1.00
Lane Grp Cap(c), veh/h	570	0	771	41	489	488	96	0	91	348	0	570
V/C Ratio(X)	0.69	0.00	0.80	0.46	0.58	0.58	0.40	0.00	0.20	0.27	0.00	0.77
Avail Cap(c_a), veh/h	1143	0	1907	191	1434	1433	191	0	180	348	0	570
HCM Platoon Ratio	1.00	1.00	1.00	1.00	1.00	1.00	1.00	1.00	1.00	1.00	1.00	1.00
Upstream Filter(I)	1.00	0.00	1.00	1.00	1.00	1.00	1.00	0.00	1.00	1.00	0.00	1.00
Uniform Delay (d), s/veh	20.2	0.0	13.1	24.8	16.0	16.1	23.5	0.0	23.2	17.6	0.0	14.6
Incr Delay (d2), s/veh	1.5	0.0	2.0	7.8	1.1	1.1	2.7	0.0	1.0	0.4	0.0	6.4
Initial Q Delay(d3),s/veh	0.0	0.0	0.0	0.0	0.0	0.0	0.0	0.0	0.0	0.0	0.0	0.0
%ile BackOfQ(50%),veh/ln	2.0	0.0	5.1	0.3	2.5	2.5	0.5	0.0	0.2	0.9	0.0	4.8
Unsig. Movement Delay, s/veh												
LnGrp Delay(d),s/veh	21.8	0.0	15.1	32.6	17.1	17.2	26.2	0.0	24.3	18.0	0.0	21.0
LnGrp LOS	C	A	B	C	B	B	C	A	C	B	A	C
Approach Vol, veh/h		1013			584			57				534
Approach Delay, s/veh		17.7			17.6			25.6				20.5
Approach LOS		B			B			C				C
Timer - Assigned Phs	1	2		4	5	6		8				
Phs Duration (G+Y+Rc), s	5.2	25.4		14.0	12.5	18.1		6.8				
Change Period (Y+Rc), s	4.0	4.0		4.0	4.0	4.0		4.0				
Max Green Setting (Gmax), s	5.5	53.0		10.0	17.0	41.5		5.5				
Max Q Clear Time (g_c+I1), s	2.5	17.1		12.0	7.5	9.1		3.1				
Green Ext Time (p_c), s	0.0	4.4		0.0	1.0	3.4		0.0				
<b>Intersection Summary</b>												
HCM 6th Ctrl Delay				18.6								
HCM 6th LOS				B								



HCM 6th Signalized Intersection Summary  
 3: US 101 NB Off-Ramp & Shiloh Road

2028 Opening Year Alter. B Project Conditions  
 Timing Plan: A.M. PEAK



Movement	EBT	EBR	WBL	WBT	NBL	NBR
Lane Configurations	↑↑			↑	↘	↗
Traffic Volume (veh/h)	359	0	0	711	492	553
Future Volume (veh/h)	359	0	0	711	492	553
Initial Q (Qb), veh	0	0	0	0	0	0
Ped-Bike Adj(A_pbT)		1.00	1.00		1.00	1.00
Parking Bus, Adj	1.00	1.00	1.00	1.00	1.00	1.00
Work Zone On Approach	No			No	No	
Adj Sat Flow, veh/h/ln	1870	0	0	1870	1870	1870
Adj Flow Rate, veh/h	395	0	0	790	647	728
Peak Hour Factor	0.91	0.91	0.90	0.90	0.76	0.76
Percent Heavy Veh, %	2	0	0	2	2	2
Cap, veh/h	1638	0	0	862	742	1161
Arrive On Green	0.46	0.00	0.00	0.46	0.42	0.42
Sat Flow, veh/h	3741	0	0	1870	1781	2790
Grp Volume(v), veh/h	395	0	0	790	647	728
Grp Sat Flow(s),veh/h/ln	1777	0	0	1870	1781	1395
Q Serve(g_s), s	4.4	0.0	0.0	25.7	21.7	13.4
Cycle Q Clear(g_c), s	4.4	0.0	0.0	25.7	21.7	13.4
Prop In Lane		0.00	0.00		1.00	1.00
Lane Grp Cap(c), veh/h	1638	0	0	862	742	1161
V/C Ratio(X)	0.24	0.00	0.00	0.92	0.87	0.63
Avail Cap(c_a), veh/h	1797	0	0	946	846	1325
HCM Platoon Ratio	1.00	1.00	1.00	1.00	1.00	1.00
Upstream Filter(I)	1.00	0.00	0.00	1.00	1.00	1.00
Uniform Delay (d), s/veh	10.7	0.0	0.0	16.4	17.5	15.0
Incr Delay (d2), s/veh	0.1	0.0	0.0	12.7	9.0	0.8
Initial Q Delay(d3),s/veh	0.0	0.0	0.0	0.0	0.0	0.0
%ile BackOfQ(50%),veh/ln	1.4	0.0	0.0	11.8	9.7	3.9
Unsig. Movement Delay, s/veh						
LnGrp Delay(d),s/veh	10.7	0.0	0.0	29.1	26.5	15.8
LnGrp LOS	B	A	A	C	C	B
Approach Vol, veh/h	395			790	1375	
Approach Delay, s/veh	10.7			29.1	20.8	
Approach LOS	B			C	C	
Timer - Assigned Phs		2			6	8
Phs Duration (G+Y+Rc), s		34.1			34.1	31.2
Change Period (Y+Rc), s		4.0			4.0	4.0
Max Green Setting (Gmax), s		33.0			33.0	31.0
Max Q Clear Time (g_c+I1), s		6.4			27.7	23.7
Green Ext Time (p_c), s		2.5			2.4	3.4
<b>Intersection Summary</b>						
HCM 6th Ctrl Delay			21.8			
HCM 6th LOS			C			

HCM Signalized Intersection Capacity Analysis 2028 Opening Year Alter. B Project Conditions  
 4: Shiloh Road & US 101 SB Off-Ramp

Timing Plan: A.M. PEAK



Movement	EBL	EBT	WBT	WBR	SBL	SBR
Lane Configurations		↑	↑		↘	↘
Traffic Volume (vph)	0	281	686	0	161	174
Future Volume (vph)	0	281	686	0	161	174
Ideal Flow (vphpl)	1900	1900	1900	1900	1900	1900
Total Lost time (s)		4.0	4.0		4.0	4.0
Lane Util. Factor		1.00	1.00		1.00	1.00
Frt		1.00	1.00		1.00	0.85
Flt Protected		1.00	1.00		0.95	1.00
Satd. Flow (prot)		1863	1863		1770	1583
Flt Permitted		1.00	1.00		0.95	1.00
Satd. Flow (perm)		1863	1863		1770	1583
Peak-hour factor, PHF	0.93	0.93	0.91	0.91	0.92	0.92
Adj. Flow (vph)	0	302	754	0	175	189
RTOR Reduction (vph)	0	0	0	0	0	144
Lane Group Flow (vph)	0	302	754	0	175	45
Turn Type		NA	NA		Perm	Perm
Protected Phases		2	6			
Permitted Phases					4	4
Actuated Green, G (s)		24.4	24.4		10.0	10.0
Effective Green, g (s)		24.4	24.4		10.0	10.0
Actuated g/C Ratio		0.58	0.58		0.24	0.24
Clearance Time (s)		4.0	4.0		4.0	4.0
Vehicle Extension (s)		3.0	3.0		3.0	3.0
Lane Grp Cap (vph)		1072	1072		417	373
v/s Ratio Prot		0.16	c0.40			
v/s Ratio Perm					c0.10	0.03
v/c Ratio		0.28	0.70		0.42	0.12
Uniform Delay, d1		4.6	6.4		13.7	12.7
Progression Factor		1.00	1.00		1.00	1.00
Incremental Delay, d2		0.1	2.1		0.7	0.1
Delay (s)		4.7	8.5		14.4	12.9
Level of Service		A	A		B	B
Approach Delay (s)		4.7	8.5		13.6	
Approach LOS		A	A		B	

Intersection Summary			
HCM 2000 Control Delay	9.0	HCM 2000 Level of Service	A
HCM 2000 Volume to Capacity ratio	0.62		
Actuated Cycle Length (s)	42.4	Sum of lost time (s)	8.0
Intersection Capacity Utilization	68.9%	ICU Level of Service	C
Analysis Period (min)	15		

c Critical Lane Group

Intersection						
Int Delay, s/veh	2.9					
Movement	EBT	EBR	WBL	WBT	NBL	NBR
Lane Configurations	↑↑		↘	↑	↘	↘
Traffic Vol, veh/h	604	25	202	633	8	138
Future Vol, veh/h	604	25	202	633	8	138
Conflicting Peds, #/hr	0	0	0	0	0	0
Sign Control	Free	Free	Free	Free	Stop	Stop
RT Channelized	-	None	-	None	-	None
Storage Length	-	-	68	-	0	0
Veh in Median Storage, #	0	-	-	0	0	-
Grade, %	0	-	-	0	0	-
Peak Hour Factor	96	96	87	87	84	84
Heavy Vehicles, %	2	2	2	2	2	2
Mvmt Flow	629	26	232	728	10	164

Major/Minor	Major1	Major2	Minor1		
Conflicting Flow All	0	0	655	0	1834 328
Stage 1	-	-	-	-	642 -
Stage 2	-	-	-	-	1192 -
Critical Hdwy	-	-	4.13	-	6.63 6.93
Critical Hdwy Stg 1	-	-	-	-	5.83 -
Critical Hdwy Stg 2	-	-	-	-	5.43 -
Follow-up Hdwy	-	-	2.219	-	3.519 3.319
Pot Cap-1 Maneuver	-	-	930	-	75 668
Stage 1	-	-	-	-	487 -
Stage 2	-	-	-	-	287 -
Platoon blocked, %	-	-	-	-	-
Mov Cap-1 Maneuver	-	-	930	-	56 668
Mov Cap-2 Maneuver	-	-	-	-	56 -
Stage 1	-	-	-	-	487 -
Stage 2	-	-	-	-	216 -

Approach	EB	WB	NB
HCM Control Delay, s	0	2.5	15.9
HCM LOS			C

Minor Lane/Major Mvmt	NBLn1	NBLn2	EBT	EBR	WBL	WBT
Capacity (veh/h)	56	668	-	-	930	-
HCM Lane V/C Ratio	0.17	0.246	-	-	0.25	-
HCM Control Delay (s)	82	12.1	-	-	10.2	-
HCM Lane LOS	F	B	-	-	B	-
HCM 95th %tile Q(veh)	0.6	1	-	-	1	-

HCM Signalized Intersection Capacity Analysis 2028 Opening Year Alter. B Project Conditions  
 6: Conde Lane & Shiloh Road

Timing Plan: A.M. PEAK



Movement	EBL	EBT	EBR	WBL	WBT	WBR	NBL	NBT	NBR	SBL	SBT	SBR
Lane Configurations												
Traffic Volume (vph)	28	382	6	10	410	232	5	0	14	233	1	40
Future Volume (vph)	28	382	6	10	410	232	5	0	14	233	1	40
Ideal Flow (vphpl)	1900	1900	1900	1900	1900	1900	1900	1900	1900	1900	1900	1900
Total Lost time (s)	4.0	4.0		4.0	4.0			4.0			4.0	4.0
Lane Util. Factor	1.00	0.95		1.00	0.95			1.00			1.00	1.00
Frt	1.00	1.00		1.00	0.95			0.90			1.00	0.85
Flt Protected	0.95	1.00		0.95	1.00			0.99			0.95	1.00
Satd. Flow (prot)	1770	3531		1770	3347			1656			1774	1583
Flt Permitted	0.95	1.00		0.95	1.00			0.99			0.95	1.00
Satd. Flow (perm)	1770	3531		1770	3347			1656			1774	1583
Peak-hour factor, PHF	0.95	0.95	0.95	0.85	0.85	0.85	0.57	0.57	0.57	0.86	0.86	0.86
Adj. Flow (vph)	29	402	6	12	482	273	9	0	25	271	1	47
RTOR Reduction (vph)	0	1	0	0	74	0	0	32	0	0	0	0
Lane Group Flow (vph)	29	407	0	12	681	0	0	2	0	0	272	47
Turn Type	Prot	NA		Prot	NA		Split	NA		Split	NA	custom
Protected Phases	5	2		1	6		7	7		4	4	
Permitted Phases												6
Actuated Green, G (s)	2.2	19.7		1.1	18.6			2.7			12.8	18.6
Effective Green, g (s)	2.2	19.7		1.1	18.6			2.7			12.8	18.6
Actuated g/C Ratio	0.04	0.38		0.02	0.36			0.05			0.24	0.36
Clearance Time (s)	4.0	4.0		4.0	4.0			4.0			4.0	4.0
Vehicle Extension (s)	3.0	3.0		3.0	3.0			3.0			3.0	3.0
Lane Grp Cap (vph)	74	1330		37	1190			85			434	562
v/s Ratio Prot	c0.02	0.12		0.01	c0.20			c0.00			c0.15	
v/s Ratio Perm												0.03
v/c Ratio	0.39	0.31		0.32	0.57			0.02			0.63	0.08
Uniform Delay, d1	24.4	11.5		25.2	13.6			23.5			17.6	11.2
Progression Factor	1.00	1.00		1.00	1.00			1.00			1.00	1.00
Incremental Delay, d2	3.4	0.1		5.1	0.7			0.1			2.8	0.1
Delay (s)	27.8	11.6		30.3	14.3			23.6			20.4	11.3
Level of Service	C	B		C	B			C			C	B
Approach Delay (s)		12.7			14.6			23.6			19.1	
Approach LOS		B			B			C			B	

Intersection Summary		
HCM 2000 Control Delay	15.2	HCM 2000 Level of Service B
HCM 2000 Volume to Capacity ratio	0.54	
Actuated Cycle Length (s)	52.3	Sum of lost time (s) 16.0
Intersection Capacity Utilization	49.6%	ICU Level of Service A
Analysis Period (min)	15	

c Critical Lane Group

Intersection												
Int Delay, s/veh	1.2											
Movement	EBL	EBT	EBR	WBL	WBT	WBR	NBL	NBT	NBR	SBL	SBT	SBR
Lane Configurations		↕	↕		↕		↕	↕			↕	
Traffic Vol, veh/h	9	306	47	0	167	0	33	0	0	1	0	18
Future Vol, veh/h	9	306	47	0	167	0	33	0	0	1	0	18
Conflicting Peds, #/hr	0	0	0	0	0	0	0	0	0	0	0	0
Sign Control	Free	Free	Free	Free	Free	Free	Stop	Stop	Stop	Stop	Stop	Stop
RT Channelized	-	-	None	-	-	None	-	-	None	-	-	None
Storage Length	-	-	150	-	-	-	0	-	-	-	-	-
Veh in Median Storage, #	-	0	-	-	0	-	-	0	-	-	0	-
Grade, %	-	0	-	-	0	-	-	0	-	-	0	-
Peak Hour Factor	91	91	91	85	85	85	100	100	100	71	71	71
Heavy Vehicles, %	2	2	2	2	2	2	2	2	2	2	2	2
Mvmt Flow	10	336	52	0	196	0	33	0	0	1	0	25

Major/Minor	Major1			Major2			Minor1			Minor2		
Conflicting Flow All	196	0	0	388	0	0	565	552	336	578	604	196
Stage 1	-	-	-	-	-	-	356	356	-	196	196	-
Stage 2	-	-	-	-	-	-	209	196	-	382	408	-
Critical Hdwy	4.12	-	-	4.12	-	-	7.12	6.52	6.22	7.12	6.52	6.22
Critical Hdwy Stg 1	-	-	-	-	-	-	6.12	5.52	-	6.12	5.52	-
Critical Hdwy Stg 2	-	-	-	-	-	-	6.12	5.52	-	6.12	5.52	-
Follow-up Hdwy	2.218	-	-	2.218	-	-	3.518	4.018	3.318	3.518	4.018	3.318
Pot Cap-1 Maneuver	1377	-	-	1170	-	-	436	442	706	427	412	845
Stage 1	-	-	-	-	-	-	661	629	-	806	739	-
Stage 2	-	-	-	-	-	-	793	739	-	640	597	-
Platoon blocked, %		-	-		-	-						
Mov Cap-1 Maneuver	1377	-	-	1170	-	-	420	438	706	424	408	845
Mov Cap-2 Maneuver	-	-	-	-	-	-	420	438	-	424	408	-
Stage 1	-	-	-	-	-	-	655	623	-	799	739	-
Stage 2	-	-	-	-	-	-	769	739	-	634	592	-

Approach	EB	WB	NB	SB
HCM Control Delay, s	0.2	0	14.3	9.6
HCM LOS			B	A

Minor Lane/Major Mvmt	NBLn1	NBLn2	EBL	EBT	EBR	WBL	WBT	WBR	SBLn1
Capacity (veh/h)	420	-	1377	-	-	1170	-	-	803
HCM Lane V/C Ratio	0.079	-	0.007	-	-	-	-	-	0.033
HCM Control Delay (s)	14.3	0	7.6	0	-	0	-	-	9.6
HCM Lane LOS	B	A	A	A	-	A	-	-	A
HCM 95th %tile Q(veh)	0.3	-	0	-	-	0	-	-	0.1

HCM 6th TWSC  
8: Old Redwood Hwy & Driveway 2

2028 Opening Year Alter. B Project Conditions  
Timing Plan: A.M. PEAK

Intersection												
Int Delay, s/veh	1.4											
Movement	EBL	EBT	EBR	WBL	WBT	WBR	NBL	NBT	NBR	SBL	SBT	SBR
Lane Configurations		↕		↕	↕			↕	↕	↕	↕	
Traffic Vol, veh/h	1	0	0	19	0	31	0	247	28	45	360	0
Future Vol, veh/h	1	0	0	19	0	31	0	247	28	45	360	0
Conflicting Peds, #/hr	0	0	0	0	0	0	0	0	1	1	0	0
Sign Control	Stop	Stop	Stop	Stop	Stop	Stop	Free	Free	Free	Free	Free	Free
RT Channelized	-	-	None	-	-	None	-	-	None	-	-	None
Storage Length	-	-	-	0	-	-	-	-	100	50	-	-
Veh in Median Storage, #	-	0	-	-	0	-	-	0	-	-	0	-
Grade, %	-	0	-	-	0	-	-	0	-	-	0	-
Peak Hour Factor	25	25	25	100	100	100	99	99	99	90	90	90
Heavy Vehicles, %	2	2	2	2	2	2	2	2	2	2	2	2
Mvmt Flow	4	0	0	19	0	31	0	249	28	50	400	0

Major/Minor	Minor2		Minor1		Major1		Major2					
Conflicting Flow All	779	778	400	750	750	250	400	0	0	278	0	0
Stage 1	500	500	-	250	250	-	-	-	-	-	-	-
Stage 2	279	278	-	500	500	-	-	-	-	-	-	-
Critical Hdwy	7.12	6.52	6.22	7.12	6.52	6.22	4.12	-	-	4.12	-	-
Critical Hdwy Stg 1	6.12	5.52	-	6.12	5.52	-	-	-	-	-	-	-
Critical Hdwy Stg 2	6.12	5.52	-	6.12	5.52	-	-	-	-	-	-	-
Follow-up Hdwy	3.518	4.018	3.318	3.518	4.018	3.318	2.218	-	-	2.218	-	-
Pot Cap-1 Maneuver	313	328	650	328	340	789	1159	-	-	1285	-	-
Stage 1	553	543	-	754	700	-	-	-	-	-	-	-
Stage 2	728	680	-	553	543	-	-	-	-	-	-	-
Platoon blocked, %								-	-	-	-	-
Mov Cap-1 Maneuver	292	315	650	318	326	788	1159	-	-	1284	-	-
Mov Cap-2 Maneuver	292	315	-	318	326	-	-	-	-	-	-	-
Stage 1	553	522	-	753	699	-	-	-	-	-	-	-
Stage 2	699	679	-	531	522	-	-	-	-	-	-	-

Approach	EB	WB	NB	SB
HCM Control Delay, s	17.5	12.5	0	0.9
HCM LOS	C	B		

Minor Lane/Major Mvmt	NBL	NBT	NBR	EBLn1	WBLn1	WBLn2	SBL	SBT	SBR
Capacity (veh/h)	1159	-	-	292	318	788	1284	-	-
HCM Lane V/C Ratio	-	-	-	0.014	0.06	0.039	0.039	-	-
HCM Control Delay (s)	0	-	-	17.5	17	9.8	7.9	-	-
HCM Lane LOS	A	-	-	C	C	A	A	-	-
HCM 95th %tile Q(veh)	0	-	-	0	0.2	0.1	0.1	-	-

Intersection						
Int Delay, s/veh	2.4					
Movement	EBT	EBR	WBL	WBT	NBL	NBR
Lane Configurations	↑	↗		↖	↖	↗
Traffic Vol, veh/h	159	145	14	59	101	10
Future Vol, veh/h	159	145	14	59	101	10
Conflicting Peds, #/hr	0	0	0	0	0	0
Sign Control	Free	Free	Free	Free	Stop	Stop
RT Channelized	-	None	-	None	-	None
Storage Length	-	200	-	-	0	0
Veh in Median Storage, #	0	-	-	0	0	-
Grade, %	0	-	-	0	0	-
Peak Hour Factor	85	85	81	81	100	100
Heavy Vehicles, %	2	2	2	2	2	2
Mvmt Flow	187	171	17	73	101	10

Major/Minor	Major1	Major2	Minor1		
Conflicting Flow All	0	0	358	0	294 187
Stage 1	-	-	-	-	187 -
Stage 2	-	-	-	-	107 -
Critical Hdwy	-	-	4.12	-	6.42 6.22
Critical Hdwy Stg 1	-	-	-	-	5.42 -
Critical Hdwy Stg 2	-	-	-	-	5.42 -
Follow-up Hdwy	-	-	2.218	-	3.518 3.318
Pot Cap-1 Maneuver	-	-	1201	-	697 855
Stage 1	-	-	-	-	845 -
Stage 2	-	-	-	-	917 -
Platoon blocked, %	-	-	-	-	-
Mov Cap-1 Maneuver	-	-	1201	-	687 855
Mov Cap-2 Maneuver	-	-	-	-	687 -
Stage 1	-	-	-	-	845 -
Stage 2	-	-	-	-	903 -

Approach	EB	WB	NB
HCM Control Delay, s	0	1.5	10.9
HCM LOS			B

Minor Lane/Major Mvmt	NBLn1	NBLn2	EBT	EBR	WBL	WBT
Capacity (veh/h)	687	855	-	-	1201	-
HCM Lane V/C Ratio	0.147	0.012	-	-	0.014	-
HCM Control Delay (s)	11.1	9.3	-	-	8	0
HCM Lane LOS	B	A	-	-	A	A
HCM 95th %tile Q(veh)	0.5	0	-	-	0	-

HCM 6th Signalized Intersection Summary      2028 Opening Year Alter. B Project Conditions  
 10: US 101 NB Off Ramp/Lakewood Drive & Old Redwood Highway      Timing Plan: A.M. PEAK

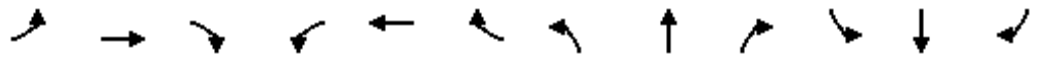

Movement	EBL	EBT	EBR	WBL	WBT	WBR	NBL	NBT	NBR	SBL	SBT	SBR
Lane Configurations	↔↔	↑			↑↑		↔	↔↔		↔↔		↔
Traffic Volume (veh/h)	173	198	0	0	520	170	258	252	90	134	0	608
Future Volume (veh/h)	173	198	0	0	520	170	258	252	90	134	0	608
Initial Q (Qb), veh	0	0	0	0	0	0	0	0	0	0	0	0
Ped-Bike Adj(A_pbT)	1.00		1.00	1.00		0.99	1.00		1.00	1.00		1.00
Parking Bus, Adj	1.00	1.00	1.00	1.00	1.00	1.00	1.00	1.00	1.00	1.00	1.00	1.00
Work Zone On Approach		No			No			No			No	
Adj Sat Flow, veh/h/ln	1870	1870	0	0	1870	1870	1870	1870	1870	1870	0	1870
Adj Flow Rate, veh/h	204	233	0	0	627	205	222	371	100	151	0	0
Peak Hour Factor	0.85	0.85	0.85	0.83	0.83	0.83	0.90	0.90	0.90	0.89	0.89	0.89
Percent Heavy Veh, %	2	2	0	0	2	2	2	2	2	2	0	2
Cap, veh/h	371	1187	0	0	1217	398	375	599	159	0	0	
Arrive On Green	0.11	0.63	0.00	0.00	0.46	0.46	0.21	0.21	0.21	0.00	0.00	0.00
Sat Flow, veh/h	3456	1870	0	0	2717	857	1781	2845	757		0	
Grp Volume(v), veh/h	204	233	0	0	424	408	222	242	229		0.0	
Grp Sat Flow(s),veh/h/ln	1728	1870	0	0	1777	1703	1781	1870	1732			
Q Serve(g_s), s	3.5	3.3	0.0	0.0	10.7	10.7	7.1	7.4	7.6			
Cycle Q Clear(g_c), s	3.5	3.3	0.0	0.0	10.7	10.7	7.1	7.4	7.6			
Prop In Lane	1.00		0.00	0.00		0.50	1.00		0.44			
Lane Grp Cap(c), veh/h	371	1187	0	0	825	790	375	394	365			
V/C Ratio(X)	0.55	0.20	0.00	0.00	0.51	0.52	0.59	0.62	0.63			
Avail Cap(c_a), veh/h	491	1187	0	0	825	790	816	856	793			
HCM Platoon Ratio	1.00	1.00	1.00	1.00	1.00	1.00	1.00	1.00	1.00			
Upstream Filter(I)	1.00	1.00	0.00	0.00	1.00	1.00	1.00	1.00	1.00			
Uniform Delay (d), s/veh	26.8	4.8	0.0	0.0	11.9	12.0	22.5	22.7	22.7			
Incr Delay (d2), s/veh	1.3	0.4	0.0	0.0	2.3	2.4	1.5	1.6	1.8			
Initial Q Delay(d3),s/veh	0.0	0.0	0.0	0.0	0.0	0.0	0.0	0.0	0.0			
%ile BackOfQ(50%),veh/ln	1.4	1.0	0.0	0.0	4.1	3.9	2.9	3.2	3.1			
Unsig. Movement Delay, s/veh												
LnGrp Delay(d),s/veh	28.1	5.2	0.0	0.0	14.2	14.4	24.0	24.2	24.5			
LnGrp LOS	C	A	A	A	B	B	C	C	C			
Approach Vol, veh/h		437			832			693				
Approach Delay, s/veh		15.9			14.3			24.3				
Approach LOS		B			B			C				
Timer - Assigned Phs		2			5	6		8				
Phs Duration (G+Y+Rc), s		45.3			10.8	34.5		18.0				
Change Period (Y+Rc), s		5.1			4.0	5.1		4.7				
Max Green Setting (Gmax), s		40.2			9.0	27.2		29.0				
Max Q Clear Time (g_c+I1), s		5.3			5.5	12.7		9.6				
Green Ext Time (p_c), s		1.4			0.2	4.6		3.4				

Intersection Summary		
HCM 6th Ctrl Delay		18.2
HCM 6th LOS		B

**Notes**  
 User approved volume balancing among the lanes for turning movement.  
 Unsignalized Delay for [SBR] is excluded from calculations of the approach delay and intersection delay.



HCM 6th Signalized Intersection Summary      2028 Opening Year Alter. B Project Conditions  
 12: US 101 SB On Ramp/US 101 SB Off Ramp & Old Redwood Highway      Timing Plan: A.M. PEAK



Movement	EBL	EBT	EBR	WBL	WBT	WBR	NBL	NBT	NBR	SBL	SBT	SBR
Lane Configurations		↑↑	↗	↘	↑↑					↘	↕	
Traffic Volume (veh/h)	0	339	337	584	574	0	0	0	0	133	1	74
Future Volume (veh/h)	0	339	337	584	574	0	0	0	0	133	1	74
Initial Q (Qb), veh	0	0	0	0	0	0				0	0	0
Ped-Bike Adj(A_pbT)	1.00		0.98	1.00		1.00				1.00		1.00
Parking Bus, Adj	1.00	1.00	1.00	1.00	1.00	1.00				1.00	1.00	1.00
Work Zone On Approach		No			No						No	
Adj Sat Flow, veh/h/ln	0	1870	1870	1870	1870	0				1870	1870	1870
Adj Flow Rate, veh/h	0	368	366	656	645	0				128	51	0
Peak Hour Factor	0.92	0.92	0.92	0.89	0.89	0.89				0.81	0.81	0.81
Percent Heavy Veh, %	0	2	2	2	2	0				2	2	2
Cap, veh/h	0	1211	532	647	2680	0				219	230	
Arrive On Green	0.00	0.34	0.34	0.36	0.75	0.00				0.12	0.12	0.00
Sat Flow, veh/h	0	3647	1560	1781	3647	0				1781	1870	0
Grp Volume(v), veh/h	0	368	366	656	645	0				128	51	0
Grp Sat Flow(s),veh/h/ln	0	1777	1560	1781	1777	0				1781	1870	0
Q Serve(g_s), s	0.0	6.1	16.1	29.0	4.3	0.0				5.4	2.0	0.0
Cycle Q Clear(g_c), s	0.0	6.1	16.1	29.0	4.3	0.0				5.4	2.0	0.0
Prop In Lane	0.00		1.00	1.00		0.00				1.00		0.00
Lane Grp Cap(c), veh/h	0	1211	532	647	2680	0				219	230	
V/C Ratio(X)	0.00	0.30	0.69	1.01	0.24	0.00				0.58	0.22	
Avail Cap(c_a), veh/h	0	1211	532	647	2680	0				223	234	
HCM Platoon Ratio	1.00	1.00	1.00	1.00	1.00	1.00				1.00	1.00	1.00
Upstream Filter(I)	0.00	1.00	1.00	1.00	1.00	0.00				1.00	1.00	0.00
Uniform Delay (d), s/veh	0.0	19.3	22.7	25.4	2.9	0.0				33.1	31.6	0.0
Incr Delay (d2), s/veh	0.0	0.6	7.1	38.8	0.2	0.0				3.8	0.5	0.0
Initial Q Delay(d3),s/veh	0.0	0.0	0.0	0.0	0.0	0.0				0.0	0.0	0.0
%ile BackOfQ(50%),veh/ln	0.0	2.5	6.6	18.2	1.0	0.0				2.5	0.9	0.0
Unsig. Movement Delay, s/veh												
LnGrp Delay(d),s/veh	0.0	20.0	29.8	64.2	3.2	0.0				36.8	32.0	0.0
LnGrp LOS	A	B	C	F	A	A				D	C	
Approach Vol, veh/h		734			1301							179
Approach Delay, s/veh		24.9			33.9							35.5
Approach LOS		C			C							D
Timer - Assigned Phs		2			5	6		8				
Phs Duration (G+Y+Rc), s		65.3			33.0	32.3		14.5				
Change Period (Y+Rc), s		5.1			4.0	5.1		4.7				
Max Green Setting (Gmax), s		60.2			29.0	27.2		10.0				
Max Q Clear Time (g_c+I1), s		6.3			31.0	18.1		7.4				
Green Ext Time (p_c), s		5.0			0.0	2.6		0.1				

**Intersection Summary**

HCM 6th Ctrl Delay	31.1
HCM 6th LOS	C























**Notes**

- User approved volume balancing among the lanes for turning movement.
- User approved ignoring U-Turning movement.
- Unsignalized Delay for [SBR] is excluded from calculations of the approach delay and intersection delay.

HCM 6th Signalized Intersection Summary  
1: Old Redwood Hwy & Shiloh Road

2028 Opening Year Alter. B Project Conditions

























Timing Plan: P.M. Peak

												
Movement	EBL	EBT	EBR	WBL	WBT	WBR	NBL	NBT	NBR	SBL	SBT	SBR
Lane Configurations												
Traffic Volume (veh/h)	257	359	249	37	334	49	225	347	21	59	246	163
Future Volume (veh/h)	257	359	249	37	334	49	225	347	21	59	246	163
Initial Q (Qb), veh	0	0	0	0	0	0	0	0	0	0	0	0
Ped-Bike Adj(A_pbT)	1.00		1.00	1.00		1.00	1.00		0.97	1.00		0.97
Parking Bus, Adj	1.00	1.00	1.00	1.00	1.00	1.00	1.00	1.00	1.00	1.00	1.00	1.00
Work Zone On Approach		No			No			No			No	
Adj Sat Flow, veh/h/ln	1870	1870	1870	1870	1870	1870	1870	1870	1870	1870	1870	1870
Adj Flow Rate, veh/h	265	370	257	41	367	54	242	373	23	63	265	175
Peak Hour Factor	0.97	0.97	0.97	0.91	0.91	0.91	0.93	0.93	0.93	0.93	0.93	0.93
Percent Heavy Veh, %	2	2	2	2	2	2	2	2	2	2	2	2
Cap, veh/h	426	447	378	48	426	403	267	515	425	99	338	278
Arrive On Green	0.24	0.24	0.24	0.25	0.25	0.25	0.15	0.28	0.28	0.06	0.18	0.18
Sat Flow, veh/h	1781	1870	1582	187	1674	1582	1781	1870	1544	1781	1870	1539
Grp Volume(v), veh/h	265	370	257	408	0	54	242	373	23	63	265	175
Grp Sat Flow(s),veh/h/ln	1781	1870	1582	1861	0	1582	1781	1870	1544	1781	1870	1539
Q Serve(g_s), s	12.9	18.2	14.3	20.3	0.0	2.6	12.9	17.5	1.1	3.4	13.1	10.2
Cycle Q Clear(g_c), s	12.9	18.2	14.3	20.3	0.0	2.6	12.9	17.5	1.1	3.4	13.1	10.2
Prop In Lane	1.00		1.00	0.10		1.00	1.00		1.00	1.00		1.00
Lane Grp Cap(c), veh/h	426	447	378	474	0	403	267	515	425	99	338	278
V/C Ratio(X)	0.62	0.83	0.68	0.86	0.00	0.13	0.91	0.72	0.05	0.64	0.78	0.63
Avail Cap(c_a), veh/h	561	589	498	730	0	621	267	840	694	110	676	556
HCM Platoon Ratio	1.00	1.00	1.00	1.00	1.00	1.00	1.00	1.00	1.00	1.00	1.00	1.00
Upstream Filter(I)	1.00	1.00	1.00	1.00	0.00	1.00	1.00	1.00	1.00	1.00	1.00	1.00
Uniform Delay (d), s/veh	32.9	34.9	33.5	34.4	0.0	27.8	40.5	31.8	25.8	44.8	37.9	36.7
Incr Delay (d2), s/veh	1.5	7.3	2.4	6.5	0.0	0.1	32.0	2.0	0.1	10.0	4.0	2.3
Initial Q Delay(d3),s/veh	0.0	0.0	0.0	0.0	0.0	0.0	0.0	0.0	0.0	0.0	0.0	0.0
%ile BackOfQ(50%),veh/ln	5.5	8.8	5.4	9.6	0.0	0.9	7.8	7.7	0.4	1.7	6.1	3.9
Unsig. Movement Delay, s/veh												
LnGrp Delay(d),s/veh	34.4	42.3	35.9	41.0	0.0	28.0	72.5	33.7	25.9	54.8	41.8	39.0
LnGrp LOS	C	D	D	D	A	C	E	C	C	D	D	D
Approach Vol, veh/h		892			462			638			503	
Approach Delay, s/veh		38.1			39.5			48.2			42.5	
Approach LOS		D			D			D			D	
Timer - Assigned Phs		2	3	4		6	7	8				
Phs Duration (G+Y+Rc), s		27.7	18.0	22.0		29.2	8.9	31.2				
Change Period (Y+Rc), s		4.5	3.5	4.5		4.5	3.5	4.5				
Max Green Setting (Gmax), s		30.5	14.5	35.0		38.0	6.0	43.5				
Max Q Clear Time (g_c+I1), s		20.2	14.9	15.1		22.3	5.4	19.5				
Green Ext Time (p_c), s		2.9	0.0	1.9		2.2	0.0	2.1				
<b>Intersection Summary</b>												
HCM 6th Ctrl Delay			41.8									
HCM 6th LOS			D									

HCM 6th Signalized Intersection Summary  
2: Shiloh Road & Hembree Ln

2028 Opening Year Alter. B Project Conditions

Timing Plan: P.M. Peak

												
Movement	EBL	EBT	EBR	WBL	WBT	WBR	NBL	NBT	NBR	SBL	SBT	SBR
Lane Configurations	 			 	 						 	
Traffic Volume (veh/h)	615	725	44	24	601	145	65	11	15	170	11	497
Future Volume (veh/h)	615	725	44	24	601	145	65	11	15	170	11	497
Initial Q (Qb), veh	0	0	0	0	0	0	0	0	0	0	0	0
Ped-Bike Adj(A_pbT)	1.00		1.00	1.00		1.00	1.00		1.00	1.00		1.00
Parking Bus, Adj	1.00	1.00	1.00	1.00	1.00	1.00	1.00	1.00	1.00	1.00	1.00	1.00
Work Zone On Approach		No			No			No			No	
Adj Sat Flow, veh/h/ln	1870	1870	1870	1870	1870	1870	1870	1870	1870	1870	1870	1870
Adj Flow Rate, veh/h	654	771	44	24	691	167	65	11	15	179	11	523
Peak Hour Factor	0.94	0.94	1.00	1.00	0.87	0.87	1.00	1.00	1.00	0.95	1.00	0.95
Percent Heavy Veh, %	2	2	2	2	2	2	2	2	2	2	2	2
Cap, veh/h	767	928	53	48	949	229	108	43	59	248	15	585
Arrive On Green	0.22	0.53	0.53	0.03	0.33	0.33	0.06	0.06	0.06	0.15	0.15	0.15
Sat Flow, veh/h	3456	1752	100	1781	2837	685	1781	717	978	1683	103	1585
Grp Volume(v), veh/h	654	0	815	24	433	425	65	0	26	190	0	523
Grp Sat Flow(s),veh/h/ln	1728	0	1852	1781	1777	1746	1781	0	1694	1786	0	1585
Q Serve(g_s), s	12.3	0.0	25.1	0.9	14.5	14.6	2.4	0.0	1.0	6.9	0.0	10.0
Cycle Q Clear(g_c), s	12.3	0.0	25.1	0.9	14.5	14.6	2.4	0.0	1.0	6.9	0.0	10.0
Prop In Lane	1.00		0.05	1.00		0.39	1.00		0.58	0.94		1.00
Lane Grp Cap(c), veh/h	767	0	981	48	594	584	108	0	102	263	0	585
V/C Ratio(X)	0.85	0.00	0.83	0.50	0.73	0.73	0.60	0.00	0.25	0.72	0.00	0.89
Avail Cap(c_a), veh/h	866	0	1447	144	1087	1067	144	0	137	263	0	585
HCM Platoon Ratio	1.00	1.00	1.00	1.00	1.00	1.00	1.00	1.00	1.00	1.00	1.00	1.00
Upstream Filter(I)	1.00	0.00	1.00	1.00	1.00	1.00	1.00	0.00	1.00	1.00	0.00	1.00
Uniform Delay (d), s/veh	25.3	0.0	13.4	32.6	19.9	19.9	31.1	0.0	30.4	27.6	0.0	20.1
Incr Delay (d2), s/veh	7.5	0.0	2.7	7.9	1.7	1.8	5.3	0.0	1.3	9.3	0.0	16.1
Initial Q Delay(d3),s/veh	0.0	0.0	0.0	0.0	0.0	0.0	0.0	0.0	0.0	0.0	0.0	0.0
%ile BackOfQ(50%),veh/ln	5.4	0.0	8.8	0.5	5.5	5.5	1.2	0.0	0.4	3.4	0.0	9.6
Unsig. Movement Delay, s/veh												
LnGrp Delay(d),s/veh	32.8	0.0	16.1	40.5	21.6	21.6	36.4	0.0	31.7	36.9	0.0	36.2
LnGrp LOS	C	A	B	D	C	C	D	A	C	D	A	D
Approach Vol, veh/h		1469			882			91			713	
Approach Delay, s/veh		23.6			22.1			35.1			36.4	
Approach LOS		C			C			D			D	
Timer - Assigned Phs	1	2		4	5	6		8				
Phs Duration (G+Y+Rc), s	5.8	39.9		14.0	19.1	26.7		8.1				
Change Period (Y+Rc), s	4.0	4.0		4.0	4.0	4.0		4.0				
Max Green Setting (Gmax), s	5.5	53.0		10.0	17.0	41.5		5.5				
Max Q Clear Time (g_c+I1), s	2.9	27.1		12.0	14.3	16.6		4.4				
Green Ext Time (p_c), s	0.0	6.2		0.0	0.7	5.5		0.0				
<b>Intersection Summary</b>												
HCM 6th Ctrl Delay				26.4								
HCM 6th LOS				C								

HCM 6th Signalized Intersection Summary  
 3: US 101 NB Off-Ramp & Shiloh Road

2028 Opening Year Alter. B Project Conditions

Timing Plan: P.M. Peak

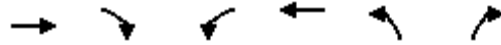

Movement	EBT	EBR	WBL	WBT	NBL	NBR
Lane Configurations	↑↑			↑	↘	↗
Traffic Volume (veh/h)	521	0	0	805	526	867
Future Volume (veh/h)	521	0	0	805	526	867
Initial Q (Qb), veh	0	0	0	0	0	0
Ped-Bike Adj(A_pbT)		1.00	1.00		1.00	1.00
Parking Bus, Adj	1.00	1.00	1.00	1.00	1.00	1.00
Work Zone On Approach	No			No	No	
Adj Sat Flow, veh/h/ln	1870	0	0	1870	1870	1870
Adj Flow Rate, veh/h	554	0	0	830	584	963
Peak Hour Factor	0.94	0.94	0.97	0.97	0.90	0.90
Percent Heavy Veh, %	2	0	0	2	2	2
Cap, veh/h	1683	0	0	886	724	1133
Arrive On Green	0.47	0.00	0.00	0.47	0.41	0.41
Sat Flow, veh/h	3741	0	0	1870	1781	2790
Grp Volume(v), veh/h	554	0	0	830	584	963
Grp Sat Flow(s),veh/h/ln	1777	0	0	1870	1781	1395
Q Serve(g_s), s	6.5	0.0	0.0	28.0	19.3	20.8
Cycle Q Clear(g_c), s	6.5	0.0	0.0	28.0	19.3	20.8
Prop In Lane		0.00	0.00		1.00	1.00
Lane Grp Cap(c), veh/h	1683	0	0	886	724	1133
V/C Ratio(X)	0.33	0.00	0.00	0.94	0.81	0.85
Avail Cap(c_a), veh/h	1761	0	0	927	829	1298
HCM Platoon Ratio	1.00	1.00	1.00	1.00	1.00	1.00
Upstream Filter(I)	1.00	0.00	0.00	1.00	1.00	1.00
Uniform Delay (d), s/veh	10.9	0.0	0.0	16.6	17.5	17.9
Incr Delay (d2), s/veh	0.1	0.0	0.0	16.1	5.3	5.0
Initial Q Delay(d3),s/veh	0.0	0.0	0.0	0.0	0.0	0.0
%ile BackOfQ(50%),veh/ln	2.1	0.0	0.0	13.5	8.1	6.7
Unsig. Movement Delay, s/veh						
LnGrp Delay(d),s/veh	11.0	0.0	0.0	32.7	22.7	22.9
LnGrp LOS	B	A	A	C	C	C
Approach Vol, veh/h	554			830	1547	
Approach Delay, s/veh	11.0			32.7	22.8	
Approach LOS	B			C	C	
Timer - Assigned Phs		2			6	8
Phs Duration (G+Y+Rc), s		35.5			35.5	31.1
Change Period (Y+Rc), s		4.0			4.0	4.0
Max Green Setting (Gmax), s		33.0			33.0	31.0
Max Q Clear Time (g_c+I1), s		8.5			30.0	22.8
Green Ext Time (p_c), s		3.6			1.6	4.2
<b>Intersection Summary</b>						
HCM 6th Ctrl Delay			23.4			
HCM 6th LOS			C			

HCM Signalized Intersection Capacity Analysis 2028 Opening Year Alter. B Project Conditions  
 4: Shiloh Road & US 101 SB Off-Ramp

Timing Plan: P.M. Peak

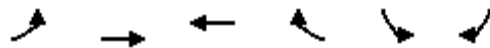

Movement	EBL	EBT	WBT	WBR	SBL	SBR
Lane Configurations		↑	↑		↘	↘
Traffic Volume (vph)	0	461	650	0	235	131
Future Volume (vph)	0	461	650	0	235	131
Ideal Flow (vphpl)	1900	1900	1900	1900	1900	1900
Total Lost time (s)		4.0	4.0		4.0	4.0
Lane Util. Factor		1.00	1.00		1.00	1.00
Frbp, ped/bikes		1.00	1.00		1.00	0.98
Flpb, ped/bikes		1.00	1.00		1.00	1.00
Frt		1.00	1.00		1.00	0.85
Flt Protected		1.00	1.00		0.95	1.00
Satd. Flow (prot)		1863	1863		1770	1549
Flt Permitted		1.00	1.00		0.95	1.00
Satd. Flow (perm)		1863	1863		1770	1549
Peak-hour factor, PHF	0.89	0.89	0.96	0.96	0.93	0.93
Adj. Flow (vph)	0	518	677	0	253	141
RTOR Reduction (vph)	0	0	0	0	0	101
Lane Group Flow (vph)	0	518	677	0	253	40
Confl. Peds. (#/hr)						1
Turn Type		NA	NA		Perm	Perm
Protected Phases		2	6			
Permitted Phases					4	4
Actuated Green, G (s)		22.3	22.3		12.0	12.0
Effective Green, g (s)		22.3	22.3		12.0	12.0
Actuated g/C Ratio		0.53	0.53		0.28	0.28
Clearance Time (s)		4.0	4.0		4.0	4.0
Vehicle Extension (s)		3.0	3.0		3.0	3.0
Lane Grp Cap (vph)		982	982		502	439
v/s Ratio Prot		0.28	c0.36			
v/s Ratio Perm					c0.14	0.03
v/c Ratio		0.53	0.69		0.50	0.09
Uniform Delay, d1		6.5	7.4		12.7	11.1
Progression Factor		1.00	1.00		1.00	1.00
Incremental Delay, d2		0.5	2.0		0.8	0.1
Delay (s)		7.1	9.5		13.5	11.2
Level of Service		A	A		B	B
Approach Delay (s)		7.1	9.5		12.7	
Approach LOS		A	A		B	
<b>Intersection Summary</b>						
HCM 2000 Control Delay			9.5		HCM 2000 Level of Service	A
HCM 2000 Volume to Capacity ratio			0.62			
Actuated Cycle Length (s)			42.3		Sum of lost time (s)	8.0
Intersection Capacity Utilization			116.3%		ICU Level of Service	H
Analysis Period (min)			15			
c Critical Lane Group						

Intersection						
Int Delay, s/veh	2.5					
Movement	EBT	EBR	WBL	WBT	NBL	NBR
Lane Configurations	↑↑		↘	↑	↘	↘
Traffic Vol, veh/h	873	28	79	672	15	149
Future Vol, veh/h	873	28	79	672	15	149
Conflicting Peds, #/hr	0	0	0	0	0	0
Sign Control	Free	Free	Free	Free	Stop	Stop
RT Channelized	-	None	-	None	-	None
Storage Length	-	-	68	-	0	0
Veh in Median Storage, #	0	-	-	0	0	-
Grade, %	0	-	-	0	0	-
Peak Hour Factor	89	89	92	92	89	89
Heavy Vehicles, %	2	2	2	2	2	2
Mvmt Flow	981	31	86	730	17	167



















Major/Minor	Major1	Major2	Minor1		
Conflicting Flow All	0	0	1012	0	1899 506
Stage 1	-	-	-	-	997 -
Stage 2	-	-	-	-	902 -
Critical Hdwy	-	-	4.13	-	6.63 6.93
Critical Hdwy Stg 1	-	-	-	-	5.83 -
Critical Hdwy Stg 2	-	-	-	-	5.43 -
Follow-up Hdwy	-	-	2.219	-	3.519 3.319
Pot Cap-1 Maneuver	-	-	683	-	68 512
Stage 1	-	-	-	-	319 -
Stage 2	-	-	-	-	395 -
Platoon blocked, %	-	-	-	-	-
Mov Cap-1 Maneuver	-	-	683	-	59 512
Mov Cap-2 Maneuver	-	-	-	-	59 -
Stage 1	-	-	-	-	319 -
Stage 2	-	-	-	-	345 -

Approach	EB	WB	NB
HCM Control Delay, s	0	1.2	22.1
HCM LOS			C

Minor Lane/Major Mvmt	NBLn1	NBLn2	EBT	EBR	WBL	WBT
Capacity (veh/h)	59	512	-	-	683	-
HCM Lane V/C Ratio	0.286	0.327	-	-	0.126	-
HCM Control Delay (s)	88.8	15.4	-	-	11	-
HCM Lane LOS	F	C	-	-	B	-
HCM 95th %tile Q(veh)	1	1.4	-	-	0.4	-

HCM Signalized Intersection Capacity Analysis 2028 Opening Year Alter. B Project Conditions  
 6: Conde Lane & Shiloh Road

Timing Plan: P.M. Peak

												
Movement	EBL	EBT	EBR	WBL	WBT	WBR	NBL	NBT	NBR	SBL	SBT	SBR
Lane Configurations												
Traffic Volume (vph)	69	492	2	7	477	289	5	3	17	297	0	39
Future Volume (vph)	69	492	2	7	477	289	5	3	17	297	0	39
Ideal Flow (vphp)	1900	1900	1900	1900	1900	1900	1900	1900	1900	1900	1900	1900
Total Lost time (s)	4.0	4.0		4.0	4.0			4.0			4.0	4.0
Lane Util. Factor	1.00	0.95		1.00	0.95			1.00			1.00	1.00
Frbp, ped/bikes	1.00	1.00		1.00	0.99			1.00			1.00	1.00
Flpb, ped/bikes	1.00	1.00		1.00	1.00			1.00			1.00	1.00
Frt	1.00	1.00		1.00	0.94			0.91			1.00	0.85
Flt Protected	0.95	1.00		0.95	1.00			0.99			0.95	1.00
Satd. Flow (prot)	1770	3537		1770	3312			1676			1770	1583
Flt Permitted	0.95	1.00		0.95	1.00			0.99			0.95	1.00
Satd. Flow (perm)	1770	3537		1770	3312			1676			1770	1583
Peak-hour factor, PHF	0.88	0.88	0.88	0.80	0.80	0.80	0.63	0.63	0.63	0.88	0.88	0.88
Adj. Flow (vph)	78	559	2	9	596	361	8	5	27	338	0	44
RTOR Reduction (vph)	0	0	0	0	79	0	0	25	0	0	0	0
Lane Group Flow (vph)	78	561	0	9	878	0	0	15	0	0	338	44
Confl. Peds. (#/hr)	1					1						
Turn Type	Prot	NA		Prot	NA		Split	NA		Split	NA	custom
Protected Phases	5	2		1	6		7	7		4	4	
Permitted Phases												6
Actuated Green, G (s)	6.4	31.6		1.2	26.4			4.9			12.4	26.4
Effective Green, g (s)	6.4	31.6		1.2	26.4			4.9			12.4	26.4
Actuated g/C Ratio	0.10	0.48		0.02	0.40			0.07			0.19	0.40
Clearance Time (s)	4.0	4.0		4.0	4.0			4.0			4.0	4.0
Vehicle Extension (s)	3.0	3.0		3.0	3.0			3.0			3.0	3.0
Lane Grp Cap (vph)	171	1690		32	1322			124			332	632
v/s Ratio Prot	c0.04	0.16		0.01	c0.26			c0.01			c0.19	
v/s Ratio Perm												0.03
v/c Ratio	0.46	0.33		0.28	0.66			0.12			1.02	0.07
Uniform Delay, d1	28.2	10.7		32.0	16.2			28.6			26.8	12.3
Progression Factor	1.00	1.00		1.00	1.00			1.00			1.00	1.00
Incremental Delay, d2	1.9	0.1		4.8	1.3			0.4			54.1	0.0
Delay (s)	30.1	10.8		36.8	17.5			29.0			80.9	12.3
Level of Service	C	B		D	B			C			F	B
Approach Delay (s)		13.2			17.7			29.0			73.0	
Approach LOS		B			B			C			E	
<b>Intersection Summary</b>												
HCM 2000 Control Delay			26.9									HCM 2000 Level of Service C
HCM 2000 Volume to Capacity ratio			0.67									
Actuated Cycle Length (s)			66.1							16.0		
Intersection Capacity Utilization			62.3%									ICU Level of Service B
Analysis Period (min)			15									
c Critical Lane Group												

Intersection												
Int Delay, s/veh	2.1											
Movement	EBL	EBT	EBR	WBL	WBT	WBR	NBL	NBT	NBR	SBL	SBT	SBR
Lane Configurations		↔	↔		↔		↔	↔			↔	
Traffic Vol, veh/h	17	336	76	0	341	0	71	0	0	0	0	14
Future Vol, veh/h	17	336	76	0	341	0	71	0	0	0	0	14
Conflicting Peds, #/hr	1	0	0	0	0	0	0	0	0	0	0	0
Sign Control	Free	Free	Free	Free	Free	Free	Stop	Stop	Stop	Stop	Stop	Stop
RT Channelized	-	-	None	-	-	None	-	-	None	-	-	None
Storage Length	-	-	150	-	-	-	0	-	-	-	-	-
Veh in Median Storage, #	-	0	-	-	0	-	-	0	-	-	0	-
Grade, %	-	0	-	-	0	-	-	0	-	-	0	-
Peak Hour Factor	94	94	94	69	69	69	100	100	100	58	58	58
Heavy Vehicles, %	2	2	2	2	2	2	2	2	2	2	2	2
Mvmt Flow	18	357	81	0	494	0	71	0	0	0	0	24

Major/Minor	Major1			Major2			Minor1			Minor2		
Conflicting Flow All	495	0	0	438	0	0	899	888	357	929	969	495
Stage 1	-	-	-	-	-	-	393	393	-	495	495	-
Stage 2	-	-	-	-	-	-	506	495	-	434	474	-
Critical Hdwy	4.12	-	-	4.12	-	-	7.12	6.52	6.22	7.12	6.52	6.22
Critical Hdwy Stg 1	-	-	-	-	-	-	6.12	5.52	-	6.12	5.52	-
Critical Hdwy Stg 2	-	-	-	-	-	-	6.12	5.52	-	6.12	5.52	-
Follow-up Hdwy	2.218	-	-	2.218	-	-	3.518	4.018	3.318	3.518	4.018	3.318
Pot Cap-1 Maneuver	1069	-	-	1122	-	-	260	283	687	248	254	575
Stage 1	-	-	-	-	-	-	632	606	-	556	546	-
Stage 2	-	-	-	-	-	-	549	546	-	600	558	-
Platoon blocked, %		-	-		-	-						
Mov Cap-1 Maneuver	1068	-	-	1122	-	-	245	276	687	244	248	574
Mov Cap-2 Maneuver	-	-	-	-	-	-	245	276	-	244	248	-
Stage 1	-	-	-	-	-	-	617	592	-	543	545	-
Stage 2	-	-	-	-	-	-	526	545	-	586	545	-

Approach	EB	WB	NB	SB
HCM Control Delay, s	0.3	0	25.6	11.5
HCM LOS			D	B

Minor Lane/Major Mvmt	NBLn1	NBLn2	EBL	EBT	EBR	WBL	WBT	WBR	SBLn1
Capacity (veh/h)	245	-	1068	-	-	1122	-	-	574
HCM Lane V/C Ratio	0.29	-	0.017	-	-	-	-	-	0.042
HCM Control Delay (s)	25.6	0	8.4	0	-	0	-	-	11.5
HCM Lane LOS	D	A	A	A	-	A	-	-	B
HCM 95th %tile Q(veh)	1.2	-	0.1	-	-	0	-	-	0.1



HCM 6th TWSC  
8: Old Redwood Hwy & Driveway 2

2028 Opening Year Alter. B Project Conditions  
Timing Plan: P.M. Peak

Intersection												
Int Delay, s/veh	2.6											
Movement	EBL	EBT	EBR	WBL	WBT	WBR	NBL	NBT	NBR	SBL	SBT	SBR
Lane Configurations		↕		↕	↕			↕	↕	↕	↕	
Traffic Vol, veh/h	3	0	0	41	0	66	0	505	45	72	427	0
Future Vol, veh/h	3	0	0	41	0	66	0	505	45	72	427	0
Conflicting Peds, #/hr	0	0	0	0	0	0	0	0	0	0	0	0
Sign Control	Stop	Stop	Stop	Stop	Stop	Stop	Free	Free	Free	Free	Free	Free
RT Channelized	-	-	None	-	-	None	-	-	None	-	-	None
Storage Length	-	-	-	0	-	-	-	-	100	50	-	-
Veh in Median Storage, #	-	0	-	-	0	-	-	0	-	-	0	-
Grade, %	-	0	-	-	0	-	-	0	-	-	0	-
Peak Hour Factor	38	38	38	100	100	100	91	91	91	94	94	94
Heavy Vehicles, %	2	2	2	2	2	2	2	2	2	2	2	2
Mvmt Flow	8	0	0	41	0	66	0	555	49	77	454	0

Major/Minor	Minor2		Minor1		Major1		Major2					
Conflicting Flow All	1221	1212	454	1163	1163	555	454	0	0	604	0	0
Stage 1	608	608	-	555	555	-	-	-	-	-	-	-
Stage 2	613	604	-	608	608	-	-	-	-	-	-	-
Critical Hdwy	7.12	6.52	6.22	7.12	6.52	6.22	4.12	-	-	4.12	-	-
Critical Hdwy Stg 1	6.12	5.52	-	6.12	5.52	-	-	-	-	-	-	-
Critical Hdwy Stg 2	6.12	5.52	-	6.12	5.52	-	-	-	-	-	-	-
Follow-up Hdwy	3.518	4.018	3.318	3.518	4.018	3.318	2.218	-	-	2.218	-	-
Pot Cap-1 Maneuver	157	182	606	172	195	531	1107	-	-	974	-	-
Stage 1	483	486	-	516	513	-	-	-	-	-	-	-
Stage 2	480	488	-	483	486	-	-	-	-	-	-	-
Platoon blocked, %								-	-	-	-	-
Mov Cap-1 Maneuver	129	168	606	162	180	531	1107	-	-	974	-	-
Mov Cap-2 Maneuver	129	168	-	162	180	-	-	-	-	-	-	-
Stage 1	483	448	-	516	513	-	-	-	-	-	-	-
Stage 2	420	488	-	445	448	-	-	-	-	-	-	-

Approach	EB		WB		NB		SB	
HCM Control Delay, s	34.7		21.1		0		1.3	
HCM LOS	D		C					

Minor Lane/Major Mvmt	NBL	NBT	NBR	EBLn1	WBLn1	WBLn2	SBL	SBT	SBR
Capacity (veh/h)	1107	-	-	129	162	531	974	-	-
HCM Lane V/C Ratio	-	-	-	0.061	0.253	0.124	0.079	-	-
HCM Control Delay (s)	0	-	-	34.7	34.6	12.7	9	-	-
HCM Lane LOS	A	-	-	D	D	B	A	-	-
HCM 95th %tile Q(veh)	0	-	-	0.2	1	0.4	0.3	-	-

Intersection						
Int Delay, s/veh	4.2					
Movement	EBT	EBR	WBL	WBT	NBL	NBR
Lane Configurations	↑	↗		↖	↖	↗
Traffic Vol, veh/h	81	233	22	111	216	21
Future Vol, veh/h	81	233	22	111	216	21
Conflicting Peds, #/hr	0	0	0	0	0	0
Sign Control	Free	Free	Free	Free	Stop	Stop
RT Channelized	-	None	-	None	-	None
Storage Length	-	200	-	-	0	0
Veh in Median Storage, #	0	-	-	0	0	-
Grade, %	0	-	-	0	0	-
Peak Hour Factor	92	92	68	68	100	100
Heavy Vehicles, %	2	2	2	2	2	2
Mvmt Flow	88	253	32	163	216	21

Major/Minor	Major1	Major2	Minor1		
Conflicting Flow All	0	0	341	0	315 88
Stage 1	-	-	-	-	88 -
Stage 2	-	-	-	-	227 -
Critical Hdwy	-	-	4.12	-	6.42 6.22
Critical Hdwy Stg 1	-	-	-	-	5.42 -
Critical Hdwy Stg 2	-	-	-	-	5.42 -
Follow-up Hdwy	-	-	2.218	-	3.518 3.318
Pot Cap-1 Maneuver	-	-	1218	-	678 970
Stage 1	-	-	-	-	935 -
Stage 2	-	-	-	-	811 -
Platoon blocked, %	-	-	-	-	-
Mov Cap-1 Maneuver	-	-	1218	-	658 970
Mov Cap-2 Maneuver	-	-	-	-	658 -
Stage 1	-	-	-	-	935 -
Stage 2	-	-	-	-	787 -

Approach	EB	WB	NB
HCM Control Delay, s	0	1.3	12.7
HCM LOS			B

Minor Lane/Major Mvmt	NBLn1	NBLn2	EBT	EBR	WBL	WBT
Capacity (veh/h)	658	970	-	-	1218	-
HCM Lane V/C Ratio	0.328	0.022	-	-	0.027	-
HCM Control Delay (s)	13.1	8.8	-	-	8	0
HCM Lane LOS	B	A	-	-	A	A
HCM 95th %tile Q(veh)	1.4	0.1	-	-	0.1	-

HCM 6th Signalized Intersection Summary      2028 Opening Year Alter. B Project Conditions  
 10: US 101 NB Off Ramp/Lakewood Drive & Old Redwood Highway      Timing Plan: P.M. Peak



Movement	EBL	EBT	EBR	WBL	WBT	WBR	NBL	NBT	NBR	SBL	SBT	SBR
Lane Configurations	↔↔	↑			↔↔		↔	↔↔		↔↔		↔
Traffic Volume (veh/h)	261	395	0	0	538	192	500	412	251	249	0	577
Future Volume (veh/h)	261	395	0	0	538	192	500	412	251	249	0	577
Initial Q (Qb), veh	0	0	0	0	0	0	0	0	0	0	0	0
Ped-Bike Adj(A_pbT)	1.00		1.00	1.00		0.98	1.00		0.99	1.00		1.00
Parking Bus, Adj	1.00	1.00	1.00	1.00	1.00	1.00	1.00	1.00	1.00	1.00	1.00	1.00
Work Zone On Approach		No			No			No			No	
Adj Sat Flow, veh/h/ln	1870	1870	0	0	1870	1870	1870	1870	1870	1870	0	1870
Adj Flow Rate, veh/h	300	454	0	0	591	211	421	618	273	259	0	0
Peak Hour Factor	0.87	0.87	0.87	0.91	0.91	0.91	0.92	0.92	0.92	0.96	0.96	0.96
Percent Heavy Veh, %	2	2	0	0	2	2	2	2	2	2	0	2
Cap, veh/h	388	1010	0	0	955	340	584	805	355	0	0	0
Arrive On Green	0.11	0.54	0.00	0.00	0.37	0.37	0.33	0.33	0.33	0.00	0.00	0.00
Sat Flow, veh/h	3456	1870	0	0	2646	909	1781	2453	1083		0	
Grp Volume(v), veh/h	300	454	0	0	411	391	421	471	420		0.0	
Grp Sat Flow(s),veh/h/ln	1728	1870	0	0	1777	1685	1781	1870	1666			
Q Serve(g_s), s	6.3	11.0	0.0	0.0	14.0	14.1	15.5	16.8	16.9			
Cycle Q Clear(g_c), s	6.3	11.0	0.0	0.0	14.0	14.1	15.5	16.8	16.9			
Prop In Lane	1.00		0.00	0.00		0.54	1.00		0.65			
Lane Grp Cap(c), veh/h	388	1010	0	0	665	631	584	614	547			
V/C Ratio(X)	0.77	0.45	0.00	0.00	0.62	0.62	0.72	0.77	0.77			
Avail Cap(c_a), veh/h	418	1010	0	0	665	631	694	729	649			
HCM Platoon Ratio	1.00	1.00	1.00	1.00	1.00	1.00	1.00	1.00	1.00			
Upstream Filter(I)	1.00	1.00	0.00	0.00	1.00	1.00	1.00	1.00	1.00			
Uniform Delay (d), s/veh	32.1	10.4	0.0	0.0	19.0	19.0	22.0	22.5	22.5			
Incr Delay (d2), s/veh	8.2	1.4	0.0	0.0	4.3	4.5	3.0	4.2	4.7			
Initial Q Delay(d3),s/veh	0.0	0.0	0.0	0.0	0.0	0.0	0.0	0.0	0.0			
%ile BackOfQ(50%),veh/ln	2.9	4.3	0.0	0.0	6.0	5.8	6.5	7.6	6.9			
Unsig. Movement Delay, s/veh												
LnGrp Delay(d),s/veh	40.3	11.8	0.0	0.0	23.2	23.5	25.0	26.6	27.1			
LnGrp LOS	D	B	A	A	C	C	C	C	C			
Approach Vol, veh/h		754			802			1312				
Approach Delay, s/veh		23.2			23.4			26.2				
Approach LOS		C			C			C				
Timer - Assigned Phs		2			5	6		8				
Phs Duration (G+Y+Rc), s		45.3			12.3	33.0		29.1				
Change Period (Y+Rc), s		5.1			4.0	5.1		4.7				
Max Green Setting (Gmax), s		40.2			9.0	27.2		29.0				
Max Q Clear Time (g_c+I1), s		13.0			8.3	16.1		18.9				
Green Ext Time (p_c), s		2.9			0.1	3.8		5.2				

**Intersection Summary**

HCM 6th Ctrl Delay	24.6
HCM 6th LOS	C

**Notes**

User approved volume balancing among the lanes for turning movement.  
 Unsignalized Delay for [SBR] is excluded from calculations of the approach delay and intersection delay.

HCM 6th Signalized Intersection Summary      2028 Opening Year Alter. B Project Conditions  
 12: US 101 SB On Ramp/US 101 SB Off Ramp & Old Redwood Highway      Timing Plan: P.M. Peak

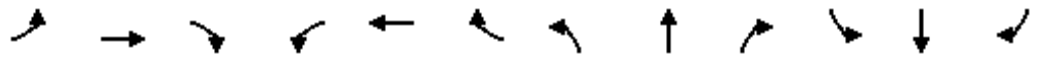

Movement	EBL	EBT	EBR	WBL	WBT	WBR	NBL	NBT	NBR	SBL	SBT	SBR
Lane Configurations		↑↑	↗	↘	↑↑					↘	↕	
Traffic Volume (veh/h)	0	535	381	381	1024	0	0	0	0	212	0	129
Future Volume (veh/h)	0	535	381	381	1024	0	0	0	0	212	0	129
Initial Q (Qb), veh	0	0	0	0	0	0				0	0	0
Ped-Bike Adj(A_pbT)	1.00		0.98	1.00		1.00				1.00		1.00
Parking Bus, Adj	1.00	1.00	1.00	1.00	1.00	1.00				1.00	1.00	1.00
Work Zone On Approach		No			No						No	
Adj Sat Flow, veh/h/ln	0	1870	1870	1870	1870	0				1870	1870	1870
Adj Flow Rate, veh/h	0	569	405	428	1151	0				205	70	0
Peak Hour Factor	0.94	0.94	0.94	0.89	0.89	0.89				0.83	0.83	0.83
Percent Heavy Veh, %	0	2	2	2	2	0				2	2	2
Cap, veh/h	0	1423	625	460	2546	0				254	267	
Arrive On Green	0.00	0.40	0.40	0.26	0.72	0.00				0.14	0.14	0.00
Sat Flow, veh/h	0	3647	1560	1781	3647	0				1781	1870	0
Grp Volume(v), veh/h	0	569	405	428	1151	0				205	70	0
Grp Sat Flow(s),veh/h/ln	0	1777	1560	1781	1777	0				1781	1870	0
Q Serve(g_s), s	0.0	8.0	14.6	16.3	9.5	0.0				7.8	2.3	0.0
Cycle Q Clear(g_c), s	0.0	8.0	14.6	16.3	9.5	0.0				7.8	2.3	0.0
Prop In Lane	0.00		1.00	1.00		0.00				1.00		0.00
Lane Grp Cap(c), veh/h	0	1423	625	460	2546	0				254	267	
V/C Ratio(X)	0.00	0.40	0.65	0.93	0.45	0.00				0.81	0.26	
Avail Cap(c_a), veh/h	0	1423	625	460	2546	0				263	277	
HCM Platoon Ratio	1.00	1.00	1.00	1.00	1.00	1.00				1.00	1.00	1.00
Upstream Filter(I)	0.00	1.00	1.00	1.00	1.00	0.00				1.00	1.00	0.00
Uniform Delay (d), s/veh	0.0	14.9	16.9	25.2	4.1	0.0				28.9	26.6	0.0
Incr Delay (d2), s/veh	0.0	0.8	5.1	25.5	0.6	0.0				16.1	0.5	0.0
Initial Q Delay(d3),s/veh	0.0	0.0	0.0	0.0	0.0	0.0				0.0	0.0	0.0
%ile BackOfQ(50%),veh/ln	0.0	3.0	5.5	9.6	2.2	0.0				4.3	1.0	0.0
Unsig. Movement Delay, s/veh												
LnGrp Delay(d),s/veh	0.0	15.7	22.0	50.7	4.7	0.0				45.0	27.1	0.0
LnGrp LOS	A	B	C	D	A	A				D	C	
Approach Vol, veh/h		974			1579						275	
Approach Delay, s/veh		18.4			17.2						40.5	
Approach LOS		B			B						D	
Timer - Assigned Phs		2			5	6		8				
Phs Duration (G+Y+Rc), s		55.0			22.0	33.0		14.7				
Change Period (Y+Rc), s		5.1			4.0	5.1		4.7				
Max Green Setting (Gmax), s		49.9			18.0	27.9		10.3				
Max Q Clear Time (g_c+I1), s		11.5			18.3	16.6		9.8				
Green Ext Time (p_c), s		10.5			0.0	4.0		0.1				

**Intersection Summary**

HCM 6th Ctrl Delay	19.9
HCM 6th LOS	B























**Notes**

- User approved volume balancing among the lanes for turning movement.
- User approved ignoring U-Turning movement.
- Unsignalized Delay for [SBR] is excluded from calculations of the approach delay and intersection delay.

HCM 6th Signalized Intersection Summary  
1: Old Redwood Hwy & Shiloh Road

2028 Opening Year Alter. B Project Conditions

























Timing Plan: Saturday Midday Peak

												
Movement	EBL	EBT	EBR	WBL	WBT	WBR	NBL	NBT	NBR	SBL	SBT	SBR
Lane Configurations												
Traffic Volume (veh/h)	156	453	282	24	488	70	293	279	27	71	228	239
Future Volume (veh/h)	156	453	282	24	488	70	293	279	27	71	228	239
Initial Q (Qb), veh	0	0	0	0	0	0	0	0	0	0	0	0
Ped-Bike Adj(A_pbT)	1.00		0.97	1.00		1.00	1.00		0.98	1.00		0.97
Parking Bus, Adj	1.00	1.00	1.00	1.00	1.00	1.00	1.00	1.00	1.00	1.00	1.00	1.00
Work Zone On Approach		No			No			No			No	
Adj Sat Flow, veh/h/ln	1870	1870	1870	1870	1870	1870	1870	1870	1870	1870	1870	1870
Adj Flow Rate, veh/h	175	509	317	28	567	81	315	300	29	78	251	263
Peak Hour Factor	0.89	0.89	0.89	0.86	0.86	0.86	0.93	0.93	0.93	0.91	0.91	0.91
Percent Heavy Veh, %	2	2	2	2	2	2	2	2	2	2	2	2
Cap, veh/h	436	458	377	27	543	484	200	496	411	79	368	303
Arrive On Green	0.25	0.25	0.25	0.31	0.31	0.31	0.11	0.26	0.26	0.04	0.20	0.20
Sat Flow, veh/h	1781	1870	1538	88	1778	1585	1781	1870	1551	1781	1870	1538
Grp Volume(v), veh/h	175	509	317	595	0	81	315	300	29	78	251	263
Grp Sat Flow(s),veh/h/ln	1781	1870	1538	1866	0	1585	1781	1870	1551	1781	1870	1538
Q Serve(g_s), s	10.2	30.5	24.4	38.0	0.0	4.7	14.0	17.5	1.7	5.4	15.5	20.6
Cycle Q Clear(g_c), s	10.2	30.5	24.4	38.0	0.0	4.7	14.0	17.5	1.7	5.4	15.5	20.6
Prop In Lane	1.00		1.00	0.05		1.00	1.00		1.00	1.00		1.00
Lane Grp Cap(c), veh/h	436	458	377	570	0	484	200	496	411	79	368	303
V/C Ratio(X)	0.40	1.11	0.84	1.04	0.00	0.17	1.57	0.61	0.07	0.99	0.68	0.87
Avail Cap(c_a), veh/h	436	458	377	570	0	484	200	654	542	79	526	433
HCM Platoon Ratio	1.00	1.00	1.00	1.00	1.00	1.00	1.00	1.00	1.00	1.00	1.00	1.00
Upstream Filter(I)	1.00	1.00	1.00	1.00	0.00	1.00	1.00	1.00	1.00	1.00	1.00	1.00
Uniform Delay (d), s/veh	39.3	47.0	44.7	43.2	0.0	31.7	55.2	40.1	34.3	59.5	46.4	48.5
Incr Delay (d2), s/veh	0.6	75.7	15.6	49.8	0.0	0.2	280.2	1.2	0.1	98.3	2.2	12.6
Initial Q Delay(d3),s/veh	0.0	0.0	0.0	0.0	0.0	0.0	0.0	0.0	0.0	0.0	0.0	0.0
%ile BackOfQ(50%),veh/ln	4.5	23.5	10.6	24.8	0.0	1.8	21.7	8.0	0.7	4.6	7.3	8.8
Unsig. Movement Delay, s/veh												
LnGrp Delay(d),s/veh	39.9	122.7	60.3	93.1	0.0	31.8	335.5	41.3	34.3	157.7	48.6	61.0
LnGrp LOS	D	F	E	F	A	C	F	D	C	F	D	E
Approach Vol, veh/h		1001			676			644			592	
Approach Delay, s/veh		88.5			85.7			184.8			68.5	
Approach LOS		F			F			F			E	
Timer - Assigned Phs		2	3	4		6	7	8				
Phs Duration (G+Y+Rc), s		35.0	18.0	29.0		42.5	9.5	37.5				
Change Period (Y+Rc), s		4.5	4.0	4.5		4.5	4.0	4.5				
Max Green Setting (Gmax), s		30.5	14.0	35.0		38.0	5.5	43.5				
Max Q Clear Time (g_c+I1), s		32.5	16.0	22.6		40.0	7.4	19.5				
Green Ext Time (p_c), s		0.0	0.0	1.9		0.0	0.0	1.6				
<b>Intersection Summary</b>												
HCM 6th Ctrl Delay				105.1								
HCM 6th LOS				F								

HCM 6th Signalized Intersection Summary  
2: Shiloh Road & Hembree Ln

2028 Opening Year Alter. B Project Conditions

Timing Plan: Saturday Midday Peak

												
Movement	EBL	EBT	EBR	WBL	WBT	WBR	NBL	NBT	NBR	SBL	SBT	SBR
Lane Configurations	 			 	 						 	
Traffic Volume (veh/h)	708	814	44	24	777	185	65	11	15	182	11	666
Future Volume (veh/h)	708	814	44	24	777	185	65	11	15	182	11	666
Initial Q (Qb), veh	0	0	0	0	0	0	0	0	0	0	0	0
Ped-Bike Adj(A_pbT)	1.00		1.00	1.00		1.00	1.00		1.00	1.00		1.00
Parking Bus, Adj	1.00	1.00	1.00	1.00	1.00	1.00	1.00	1.00	1.00	1.00	1.00	1.00
Work Zone On Approach		No			No			No			No	
Adj Sat Flow, veh/h/ln	1870	1870	1870	1870	1870	1870	1870	1870	1870	1870	1870	1870
Adj Flow Rate, veh/h	753	866	44	24	809	193	65	11	15	200	11	732
Peak Hour Factor	0.94	0.94	1.00	1.00	0.96	0.96	1.00	1.00	1.00	0.91	1.00	0.91
Percent Heavy Veh, %	2	2	2	2	2	2	2	2	2	2	2	2
Cap, veh/h	788	1003	51	47	1043	249	101	41	56	227	12	574
Arrive On Green	0.23	0.57	0.57	0.03	0.37	0.37	0.06	0.06	0.06	0.13	0.13	0.13
Sat Flow, veh/h	3456	1765	90	1781	2846	679	1781	717	978	1693	93	1585
Grp Volume(v), veh/h	753	0	910	24	505	497	65	0	26	211	0	732
Grp Sat Flow(s),veh/h/ln	1728	0	1854	1781	1777	1748	1781	0	1694	1786	0	1585
Q Serve(g_s), s	16.0	0.0	31.0	1.0	18.8	18.8	2.7	0.0	1.1	8.7	0.0	10.0
Cycle Q Clear(g_c), s	16.0	0.0	31.0	1.0	18.8	18.8	2.7	0.0	1.1	8.7	0.0	10.0
Prop In Lane	1.00		0.05	1.00		0.39	1.00		0.58	0.95		1.00
Lane Grp Cap(c), veh/h	788	0	1054	47	651	641	101	0	96	239	0	574
V/C Ratio(X)	0.96	0.00	0.86	0.51	0.78	0.78	0.64	0.00	0.27	0.88	0.00	1.28
Avail Cap(c_a), veh/h	788	0	1318	131	989	972	131	0	125	239	0	574
HCM Platoon Ratio	1.00	1.00	1.00	1.00	1.00	1.00	1.00	1.00	1.00	1.00	1.00	1.00
Upstream Filter(I)	1.00	0.00	1.00	1.00	1.00	1.00	1.00	0.00	1.00	1.00	0.00	1.00
Uniform Delay (d), s/veh	28.4	0.0	13.7	35.8	20.9	20.9	34.4	0.0	33.7	31.7	0.0	23.8
Incr Delay (d2), s/veh	21.9	0.0	5.1	8.4	2.2	2.2	6.6	0.0	1.5	29.3	0.0	137.2
Initial Q Delay(d3),s/veh	0.0	0.0	0.0	0.0	0.0	0.0	0.0	0.0	0.0	0.0	0.0	0.0
%ile BackOfQ(50%),veh/ln	8.5	0.0	11.5	0.5	7.3	7.2	1.3	0.0	0.5	5.5	0.0	31.1
Unsig. Movement Delay, s/veh												
LnGrp Delay(d),s/veh	50.3	0.0	18.8	44.3	23.1	23.1	41.0	0.0	35.2	61.0	0.0	161.0
LnGrp LOS	D	A	B	D	C	C	D	A	D	E	A	F
Approach Vol, veh/h		1663			1026			91				943
Approach Delay, s/veh		33.1			23.6			39.4				138.6
Approach LOS		C			C			D				F
Timer - Assigned Phs	1	2		4	5	6		8				
Phs Duration (G+Y+Rc), s	6.0	46.4		14.0	21.0	31.3		8.2				
Change Period (Y+Rc), s	4.0	4.0		4.0	4.0	4.0		4.0				
Max Green Setting (Gmax), s	5.5	53.0		10.0	17.0	41.5		5.5				
Max Q Clear Time (g_c+I1), s	3.0	33.0		12.0	18.0	20.8		4.7				
Green Ext Time (p_c), s	0.0	6.7		0.0	0.0	6.3		0.0				
<b>Intersection Summary</b>												
HCM 6th Ctrl Delay				57.3								
HCM 6th LOS				E								

HCM 6th Signalized Intersection Summary  
 3: US 101 NB Off-Ramp & Shiloh Road

2028 Opening Year Alter. B Project Conditions

Timing Plan: Saturday Midday Peak

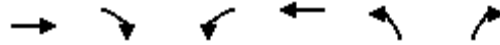

Movement	EBT	EBR	WBL	WBT	NBL	NBR
Lane Configurations	↑↑			↑	↘	↗
Traffic Volume (veh/h)	624	0	0	1105	401	931
Future Volume (veh/h)	624	0	0	1105	401	931
Initial Q (Qb), veh	0	0	0	0	0	0
Ped-Bike Adj(A_pbT)		1.00	1.00		1.00	1.00
Parking Bus, Adj	1.00	1.00	1.00	1.00	1.00	1.00
Work Zone On Approach	No			No	No	
Adj Sat Flow, veh/h/ln	1870	0	0	1870	1870	1870
Adj Flow Rate, veh/h	624	0	0	1105	401	931
Peak Hour Factor	1.00	1.00	1.00	1.00	1.00	1.00
Percent Heavy Veh, %	2	0	0	2	2	2
Cap, veh/h	1837	0	0	967	656	1027
Arrive On Green	0.52	0.00	0.00	0.52	0.37	0.37
Sat Flow, veh/h	3741	0	0	1870	1781	2790
Grp Volume(v), veh/h	624	0	0	1105	401	931
Grp Sat Flow(s),veh/h/ln	1777	0	0	1870	1781	1395
Q Serve(g_s), s	8.1	0.0	0.0	40.5	14.4	24.8
Cycle Q Clear(g_c), s	8.1	0.0	0.0	40.5	14.4	24.8
Prop In Lane		0.00	0.00		1.00	1.00
Lane Grp Cap(c), veh/h	1837	0	0	967	656	1027
V/C Ratio(X)	0.34	0.00	0.00	1.14	0.61	0.91
Avail Cap(c_a), veh/h	1837	0	0	967	693	1086
HCM Platoon Ratio	1.00	1.00	1.00	1.00	1.00	1.00
Upstream Filter(I)	1.00	0.00	0.00	1.00	1.00	1.00
Uniform Delay (d), s/veh	11.1	0.0	0.0	18.9	20.2	23.5
Incr Delay (d2), s/veh	0.1	0.0	0.0	76.8	1.5	10.5
Initial Q Delay(d3),s/veh	0.0	0.0	0.0	0.0	0.0	0.0
%ile BackOfQ(50%),veh/ln	2.7	0.0	0.0	35.0	5.9	9.1
Unsig. Movement Delay, s/veh						
LnGrp Delay(d),s/veh	11.2	0.0	0.0	95.7	21.6	34.0
LnGrp LOS	B	A	A	F	C	C
Approach Vol, veh/h	624			1105	1332	
Approach Delay, s/veh	11.2			95.7	30.3	
Approach LOS	B			F	C	
Timer - Assigned Phs		2			6	8
Phs Duration (G+Y+Rc), s		45.0			45.0	33.3
Change Period (Y+Rc), s		4.5			4.5	4.5
Max Green Setting (Gmax), s		40.5			40.5	30.5
Max Q Clear Time (g_c+I1), s		10.1			42.5	26.8
Green Ext Time (p_c), s		4.3			0.0	2.0
<b>Intersection Summary</b>						
HCM 6th Ctrl Delay			50.0			
HCM 6th LOS			D			

# HCM Signalized Intersection Capacity Analysis 2028 Opening Year Alter. B Project Conditions

## 4: Shiloh Road & US 101 SB Off-Ramp

Timing Plan: Saturday Midday Peak



Movement	EBL	EBT	WBT	WBR	SBL	SBR
Lane Configurations		↑	↑		↙	↗
Traffic Volume (vph)	0	348	633	0	364	174
Future Volume (vph)	0	348	633	0	364	174
Ideal Flow (vphpl)	1900	1900	1900	1900	1900	1900
Total Lost time (s)		4.5	4.5		4.5	4.5
Lane Util. Factor		1.00	1.00		1.00	1.00
Frbp, ped/bikes		1.00	1.00		1.00	1.00
Flpb, ped/bikes		1.00	1.00		1.00	1.00
Frt		1.00	1.00		1.00	0.85
Flt Protected		1.00	1.00		0.95	1.00
Satd. Flow (prot)		1863	1863		1770	1583
Flt Permitted		1.00	1.00		0.95	1.00
Satd. Flow (perm)		1863	1863		1770	1583
Peak-hour factor, PHF	0.96	0.96	0.96	0.96	0.68	0.68
Adj. Flow (vph)	0	362	659	0	535	256
RTOR Reduction (vph)	0	0	0	0	0	166
Lane Group Flow (vph)	0	363	659	0	535	90
Confl. Bikes (#/hr)				2		
Turn Type		NA	NA		Perm	Perm
Protected Phases		2	6			
Permitted Phases					4	4
Actuated Green, G (s)		22.2	22.2		16.8	16.8
Effective Green, g (s)		22.2	22.2		16.8	16.8
Actuated g/C Ratio		0.46	0.46		0.35	0.35
Clearance Time (s)		4.5	4.5		4.5	4.5
Vehicle Extension (s)		3.0	3.0		3.0	3.0
Lane Grp Cap (vph)		861	861		619	554
v/s Ratio Prot		0.19	c0.35			
v/s Ratio Perm					c0.30	0.06
v/c Ratio		0.42	0.77		0.86	0.16
Uniform Delay, d1		8.6	10.7		14.5	10.7
Progression Factor		1.00	1.00		1.00	1.00
Incremental Delay, d2		0.3	4.1		12.0	0.1
Delay (s)		8.9	14.8		26.5	10.9
Level of Service		A	B		C	B
Approach Delay (s)		8.9	14.8		21.5	
Approach LOS		A	B		C	
<b>Intersection Summary</b>						
HCM 2000 Control Delay			16.6		HCM 2000 Level of Service	B
HCM 2000 Volume to Capacity ratio			0.81			
Actuated Cycle Length (s)			48.0		Sum of lost time (s)	9.0
Intersection Capacity Utilization			132.4%		ICU Level of Service	H
Analysis Period (min)			15			
c Critical Lane Group						



Intersection						
Int Delay, s/veh	2.3					
Movement	EBT	EBR	WBL	WBT	NBL	NBR
Lane Configurations	↑↑		↘	↑	↘	↘
Traffic Vol, veh/h	642	23	92	709	18	89
Future Vol, veh/h	642	23	92	709	18	89
Conflicting Peds, #/hr	0	0	0	0	1	0
Sign Control	Free	Free	Free	Free	Stop	Stop
RT Channelized	-	None	-	None	-	None
Storage Length	-	-	68	-	0	0
Veh in Median Storage, #	0	-	-	0	0	-
Grade, %	0	-	-	0	0	-
Peak Hour Factor	92	92	87	87	78	78
Heavy Vehicles, %	2	2	2	2	2	2
Mvmt Flow	698	25	106	815	23	114

Major/Minor	Major1	Major2	Minor1		
Conflicting Flow All	0	0	723	0	1739 362
Stage 1	-	-	-	-	711 -
Stage 2	-	-	-	-	1028 -
Critical Hdwy	-	-	4.13	-	6.63 6.93
Critical Hdwy Stg 1	-	-	-	-	5.83 -
Critical Hdwy Stg 2	-	-	-	-	5.43 -
Follow-up Hdwy	-	-	2.219	-	3.519 3.319
Pot Cap-1 Maneuver	-	-	877	-	87 635
Stage 1	-	-	-	-	449 -
Stage 2	-	-	-	-	344 -
Platoon blocked, %	-	-	-	-	-
Mov Cap-1 Maneuver	-	-	877	-	76 635
Mov Cap-2 Maneuver	-	-	-	-	76 -
Stage 1	-	-	-	-	449 -
Stage 2	-	-	-	-	302 -

Approach	EB	WB	NB
HCM Control Delay, s	0	1.1	22
HCM LOS			C

Minor Lane/Major Mvmt	NBLn1	NBLn2	EBT	EBR	WBL	WBT
Capacity (veh/h)	76	635	-	-	877	-
HCM Lane V/C Ratio	0.304	0.18	-	-	0.121	-
HCM Control Delay (s)	71.8	11.9	-	-	9.7	-
HCM Lane LOS	F	B	-	-	A	-
HCM 95th %tile Q(veh)	1.1	0.7	-	-	0.4	-

# HCM Signalized Intersection Capacity Analysis 2028 Opening Year Alter. B Project Conditions

## 6: Conde Lane & Shiloh Road

Timing Plan: Saturday Midday Peak



Movement	EBL	EBT	EBR	WBL	WBT	WBR	NBL	NBT	NBR	SBL	SBT	SBR
Lane Configurations												
Traffic Volume (vph)	33	432	1	10	481	232	1	0	7	224	0	32
Future Volume (vph)	33	432	1	10	481	232	1	0	7	224	0	32
Ideal Flow (vphp)	1900	1900	1900	1900	1900	1900	1900	1900	1900	1900	1900	1900
Total Lost time (s)	4.5	4.5		4.5	4.5			4.5			4.5	4.5
Lane Util. Factor	1.00	0.95		1.00	0.95			1.00			1.00	1.00
Frbp, ped/bikes	1.00	1.00		1.00	0.99			1.00			1.00	1.00
Flpb, ped/bikes	1.00	1.00		1.00	1.00			1.00			1.00	1.00
Frt	1.00	1.00		1.00	0.95			0.88			1.00	0.85
Flt Protected	0.95	1.00		0.95	1.00			0.99			0.95	1.00
Satd. Flow (prot)	1770	3538		1770	3342			1636			1770	1583
Flt Permitted	0.95	1.00		0.95	1.00			0.99			0.95	1.00
Satd. Flow (perm)	1770	3538		1770	3342			1636			1770	1583
Peak-hour factor, PHF	0.96	0.96	0.96	0.91	0.91	0.91	0.58	0.58	0.58	0.78	0.78	0.78
Adj. Flow (vph)	34	450	1	11	529	255	2	0	12	287	0	41
RTOR Reduction (vph)	0	0	0	0	53	0	0	14	0	0	0	0
Lane Group Flow (vph)	34	451	0	11	731	0	0	0	0	0	287	41
Confl. Bikes (#/hr)						2						
Turn Type	Prot	NA		Prot	NA		Split	NA		Split	NA	custom
Protected Phases	5	2		1	6		7	7		4	4	
Permitted Phases												6
Actuated Green, G (s)	2.4	20.1		1.0	18.7			1.2			12.3	18.7
Effective Green, g (s)	2.4	20.1		1.0	18.7			1.2			12.3	18.7
Actuated g/C Ratio	0.05	0.38		0.02	0.36			0.02			0.23	0.36
Clearance Time (s)	4.5	4.5		4.5	4.5			4.5			4.5	4.5
Vehicle Extension (s)	3.0	3.0		3.0	3.0			3.0			3.0	3.0
Lane Grp Cap (vph)	80	1351		33	1188			37			413	562
v/s Ratio Prot	c0.02	0.13		0.01	c0.22			c0.00			c0.16	
v/s Ratio Perm												0.03
v/c Ratio	0.42	0.33		0.33	0.62			0.01			0.69	0.07
Uniform Delay, d1	24.4	11.5		25.5	14.0			25.1			18.4	11.2
Progression Factor	1.00	1.00		1.00	1.00			1.00			1.00	1.00
Incremental Delay, d2	3.6	0.1		5.9	1.0			0.1			5.0	0.1
Delay (s)	28.0	11.7		31.4	14.9			25.2			23.5	11.3
Level of Service	C	B		C	B			C			C	B
Approach Delay (s)		12.8			15.2			25.2			21.9	
Approach LOS		B			B			C			C	

Intersection Summary		
HCM 2000 Control Delay	15.9	HCM 2000 Level of Service
HCM 2000 Volume to Capacity ratio	0.61	B
Actuated Cycle Length (s)	52.6	Sum of lost time (s)
Intersection Capacity Utilization	54.0%	18.0
Analysis Period (min)	15	ICU Level of Service
		A
c Critical Lane Group		

HCM 6th TWSC  
7: Driveway 1/Gridley Drive & Shiloh Road

2028 Opening Year Alter. B Project Conditions  
Timing Plan: Saturday Midday Peak

Intersection												
Int Delay, s/veh	4.9											
Movement	EBL	EBT	EBR	WBL	WBT	WBR	NBL	NBT	NBR	SBL	SBT	SBR
Lane Configurations		↕	↕		↕		↕	↕			↕	
Traffic Vol, veh/h	23	436	103	0	450	0	113	0	0	0	0	20
Future Vol, veh/h	23	436	103	0	450	0	113	0	0	0	0	20
Conflicting Peds, #/hr	1	0	0	0	0	0	0	0	0	0	0	0
Sign Control	Free	Free	Free	Free	Free	Free	Stop	Stop	Stop	Stop	Stop	Stop
RT Channelized	-	-	None	-	-	None	-	-	None	-	-	None
Storage Length	-	-	150	-	-	-	0	-	-	-	-	-
Veh in Median Storage, #	-	0	-	-	0	-	-	0	-	-	0	-
Grade, %	-	0	-	-	0	-	-	0	-	-	0	-
Peak Hour Factor	93	93	93	88	88	88	100	100	100	56	56	56
Heavy Vehicles, %	2	2	2	2	2	2	2	2	2	2	2	2
Mvmt Flow	25	469	111	0	511	0	113	0	0	0	0	36

Major/Minor	Major1			Major2			Minor1			Minor2		
Conflicting Flow All	512	0	0	580	0	0	1048	1031	469	1087	1142	512
Stage 1	-	-	-	-	-	-	519	519	-	512	512	-
Stage 2	-	-	-	-	-	-	529	512	-	575	630	-
Critical Hdwy	4.12	-	-	4.12	-	-	7.12	6.52	6.22	7.12	6.52	6.22
Critical Hdwy Stg 1	-	-	-	-	-	-	6.12	5.52	-	6.12	5.52	-
Critical Hdwy Stg 2	-	-	-	-	-	-	6.12	5.52	-	6.12	5.52	-
Follow-up Hdwy	2.218	-	-	2.218	-	-	3.518	4.018	3.318	3.518	4.018	3.318
Pot Cap-1 Maneuver	1053	-	-	994	-	-	206	233	594	194	200	562
Stage 1	-	-	-	-	-	-	540	533	-	545	536	-
Stage 2	-	-	-	-	-	-	533	536	-	503	475	-
Platoon blocked, %	-	-	-	-	-	-	-	-	-	-	-	-
Mov Cap-1 Maneuver	1052	-	-	994	-	-	188	224	594	189	193	561
Mov Cap-2 Maneuver	-	-	-	-	-	-	188	224	-	189	193	-
Stage 1	-	-	-	-	-	-	521	514	-	525	535	-
Stage 2	-	-	-	-	-	-	499	535	-	485	458	-

Approach	EB	WB	NB	SB
HCM Control Delay, s	0.3	0	49.4	11.9
HCM LOS			E	B

Minor Lane/Major Mvmt	NBLn1	NBLn2	EBL	EBT	EBR	WBL	WBT	WBR	SBLn1
Capacity (veh/h)	188	-	1052	-	-	994	-	-	561
HCM Lane V/C Ratio	0.601	-	0.024	-	-	-	-	-	0.064
HCM Control Delay (s)	49.4	0	8.5	0	-	0	-	-	11.9
HCM Lane LOS	E	A	A	A	-	A	-	-	B
HCM 95th %tile Q(veh)	3.3	-	0.1	-	-	0	-	-	0.2

HCM 6th TWSC  
8: Old Redwood Hwy & Driveway 2

2028 Opening Year Alter. B Project Conditions

Timing Plan: Saturday Midday Peak

Intersection												
Int Delay, s/veh	4.1											
Movement	EBL	EBT	EBR	WBL	WBT	WBR	NBL	NBT	NBR	SBL	SBT	SBR
Lane Configurations		↕		↕	↕			↕	↕	↕	↕	
Traffic Vol, veh/h	1	0	2	67	0	106	1	459	61	97	389	5
Future Vol, veh/h	1	0	2	67	0	106	1	459	61	97	389	5
Conflicting Peds, #/hr	0	0	0	0	0	0	1	0	4	4	0	1
Sign Control	Stop	Stop	Stop	Stop	Stop	Stop	Free	Free	Free	Free	Free	Free
RT Channelized	-	-	None	-	-	None	-	-	None	-	-	None
Storage Length	-	-	-	0	-	-	-	-	100	50	-	-
Veh in Median Storage, #	-	0	-	-	0	-	-	0	-	-	0	-
Grade, %	-	0	-	-	0	-	-	0	-	-	0	-
Peak Hour Factor	38	38	38	100	100	100	94	94	94	93	93	93
Heavy Vehicles, %	2	2	2	2	2	2	2	2	2	2	2	2
Mvmt Flow	3	0	5	67	0	106	1	488	65	104	418	5

Major/Minor	Minor2		Minor1		Major1		Major2					
Conflicting Flow All	1206	1189	422	1125	1126	492	424	0	0	557	0	0
Stage 1	630	630	-	494	494	-	-	-	-	-	-	-
Stage 2	576	559	-	631	632	-	-	-	-	-	-	-
Critical Hdwy	7.12	6.52	6.22	7.12	6.52	6.22	4.12	-	-	4.12	-	-
Critical Hdwy Stg 1	6.12	5.52	-	6.12	5.52	-	-	-	-	-	-	-
Critical Hdwy Stg 2	6.12	5.52	-	6.12	5.52	-	-	-	-	-	-	-
Follow-up Hdwy	3.518	4.018	3.318	3.518	4.018	3.318	2.218	-	-	2.218	-	-
Pot Cap-1 Maneuver	160	188	632	182	205	577	1135	-	-	1014	-	-
Stage 1	470	475	-	557	546	-	-	-	-	-	-	-
Stage 2	503	511	-	469	474	-	-	-	-	-	-	-
Platoon blocked, %								-	-	-	-	-
Mov Cap-1 Maneuver	120	168	631	165	183	575	1134	-	-	1010	-	-
Mov Cap-2 Maneuver	120	168	-	165	183	-	-	-	-	-	-	-
Stage 1	469	426	-	554	543	-	-	-	-	-	-	-
Stage 2	410	508	-	417	425	-	-	-	-	-	-	-

Approach	EB		WB		NB		SB	
HCM Control Delay, s	19.2		23.7		0		1.8	
HCM LOS	C		C					

Minor Lane/Major Mvmt	NBL	NBT	NBR	EBLn1	WBLn1	WBLn2	SBL	SBT	SBR
Capacity (veh/h)	1134	-	-	261	165	575	1010	-	-
HCM Lane V/C Ratio	0.001	-	-	0.03	0.406	0.184	0.103	-	-
HCM Control Delay (s)	8.2	0	-	19.2	41	12.7	9	-	-
HCM Lane LOS	A	A	-	C	E	B	A	-	-
HCM 95th %tile Q(veh)	0	-	-	0.1	1.8	0.7	0.3	-	-

Intersection						
Int Delay, s/veh	6.3					
Movement	EBT	EBR	WBL	WBT	NBL	NBR
Lane Configurations	↑	↗		↖	↖	↗
Traffic Vol, veh/h	105	315	30	98	345	33
Future Vol, veh/h	105	315	30	98	345	33
Conflicting Peds, #/hr	0	1	0	0	0	0
Sign Control	Free	Free	Free	Free	Stop	Stop
RT Channelized	-	None	-	None	-	None
Storage Length	-	200	-	-	0	0
Veh in Median Storage, #	0	-	-	0	0	-
Grade, %	0	-	-	0	0	-
Peak Hour Factor	88	88	80	80	100	100
Heavy Vehicles, %	2	2	2	2	2	2
Mvmt Flow	119	358	38	123	345	33

Major/Minor	Major1	Major2	Minor1	Minor2	Minor3
Conflicting Flow All	0	0	478	0	319
Stage 1	-	-	-	-	120
Stage 2	-	-	-	-	199
Critical Hdwy	-	-	4.12	-	6.42
Critical Hdwy Stg 1	-	-	-	-	5.42
Critical Hdwy Stg 2	-	-	-	-	5.42
Follow-up Hdwy	-	-	2.218	-	3.518
Pot Cap-1 Maneuver	-	-	1084	-	674
Stage 1	-	-	-	-	905
Stage 2	-	-	-	-	835
Platoon blocked, %	-	-	-	-	-
Mov Cap-1 Maneuver	-	-	1083	-	648
Mov Cap-2 Maneuver	-	-	-	-	648
Stage 1	-	-	-	-	904
Stage 2	-	-	-	-	803

Approach	EB	WB	NB
HCM Control Delay, s	0	2	16
HCM LOS			C

Minor Lane/Major Mvmt	NBLn1	NBLn2	EBT	EBR	WBL	WBT
Capacity (veh/h)	648	930	-	-	1083	-
HCM Lane V/C Ratio	0.532	0.035	-	-	0.035	-
HCM Control Delay (s)	16.7	9	-	-	8.4	0
HCM Lane LOS	C	A	-	-	A	A
HCM 95th %tile Q(veh)	3.2	0.1	-	-	0.1	-

HCM 6th Signalized Intersection Summary      2028 Opening Year Alter. B Project Conditions  
 10: US 101 NB Off Ramp/Lakewood Drive & Old Redwood Highway      Timing Plan: Saturday Midday Peak



Movement	EBL	EBT	EBR	WBL	WBT	WBR	NBL	NBT	NBR	SBL	SBT	SBR
Lane Configurations	↔↔	↑			↑↑		↔	↔↔		↔↔		↔
Traffic Volume (veh/h)	287	374	0	0	569	276	320	303	142	244	0	700
Future Volume (veh/h)	287	374	0	0	569	276	320	303	142	244	0	700
Initial Q (Qb), veh	0	0	0	0	0	0	0	0	0	0	0	0
Ped-Bike Adj(A_pbT)	1.00		1.00	1.00		0.99	1.00		1.00	1.00		1.00
Parking Bus, Adj	1.00	1.00	1.00	1.00	1.00	1.00	1.00	1.00	1.00	1.00	1.00	1.00
Work Zone On Approach		No			No			No			No	
Adj Sat Flow, veh/h/ln	1870	1870	0	0	1870	1870	1870	1870	1870	1870	0	1870
Adj Flow Rate, veh/h	302	394	0	0	639	310	260	402	145	277	0	0
Peak Hour Factor	0.95	0.95	0.95	0.89	0.89	0.89	0.98	0.98	0.98	0.88	0.88	0.88
Percent Heavy Veh, %	2	2	0	0	2	2	2	2	2	2	0	2
Cap, veh/h	397	1173	0	0	1022	496	418	618	220	0	0	0
Arrive On Green	0.11	0.63	0.00	0.00	0.44	0.44	0.23	0.23	0.23	0.00	0.00	0.00
Sat Flow, veh/h	3456	1870	0	0	2400	1119	1781	2633	938		0	
Grp Volume(v), veh/h	302	394	0	0	492	457	260	284	263		0.0	
Grp Sat Flow(s),veh/h/ln	1728	1870	0	0	1777	1649	1781	1870	1700			
Q Serve(g_s), s	5.5	6.5	0.0	0.0	13.9	13.9	8.5	8.9	9.1			
Cycle Q Clear(g_c), s	5.5	6.5	0.0	0.0	13.9	13.9	8.5	8.9	9.1			
Prop In Lane	1.00		0.00	0.00		0.68	1.00		0.55			
Lane Grp Cap(c), veh/h	397	1173	0	0	787	730	418	439	399			
V/C Ratio(X)	0.76	0.34	0.00	0.00	0.63	0.63	0.62	0.65	0.66			
Avail Cap(c_a), veh/h	398	1173	0	0	787	730	799	839	763			
HCM Platoon Ratio	1.00	1.00	1.00	1.00	1.00	1.00	1.00	1.00	1.00			
Upstream Filter(I)	1.00	1.00	0.00	0.00	1.00	1.00	1.00	1.00	1.00			
Uniform Delay (d), s/veh	27.9	5.7	0.0	0.0	14.0	14.0	22.3	22.5	22.5			
Incr Delay (d2), s/veh	8.3	0.8	0.0	0.0	3.7	4.0	1.5	1.6	1.9			
Initial Q Delay(d3),s/veh	0.0	0.0	0.0	0.0	0.0	0.0	0.0	0.0	0.0			
%ile BackOfQ(50%),veh/ln	2.6	2.1	0.0	0.0	5.6	5.2	3.5	3.9	3.6			
Unsig. Movement Delay, s/veh												
LnGrp Delay(d),s/veh	36.2	6.5	0.0	0.0	17.7	18.0	23.8	24.1	24.4			
LnGrp LOS	D	A	A	A	B	B	C	C	C			
Approach Vol, veh/h		696			949			807				
Approach Delay, s/veh		19.4			17.8			24.1				
Approach LOS		B			B			C				
Timer - Assigned Phs		2			5	6		8				
Phs Duration (G+Y+Rc), s		45.3			12.0	33.3		19.8				
Change Period (Y+Rc), s		4.5			4.5	4.5		4.5				
Max Green Setting (Gmax), s		40.8			7.5	28.8		29.2				
Max Q Clear Time (g_c+I1), s		8.5			7.5	15.9		11.1				
Green Ext Time (p_c), s		2.5			0.0	5.0		4.0				

**Intersection Summary**

HCM 6th Ctrl Delay	20.3
HCM 6th LOS	C

**Notes**

User approved volume balancing among the lanes for turning movement.  
 Unsignalized Delay for [SBR] is excluded from calculations of the approach delay and intersection delay.

HCM 6th Signalized Intersection Summary 2028 Opening Year Alter. B Project Conditions  
 12: US 101 SB On Ramp/US 101 SB Off Ramp & Old Redwood Highway Timing Plan: Saturday Midday Peak



Movement	EBL	EBT	EBR	WBL	WBT	WBR	NBL	NBT	NBR	SBL	SBT	SBR
Lane Configurations		↑↑	↗	↖	↑↑					↘	↕	
Traffic Volume (veh/h)	0	550	419	487	818	0	0	0	0	212	1	87
Future Volume (veh/h)	0	550	419	487	818	0	0	0	0	212	1	87
Initial Q (Qb), veh	0	0	0	0	0	0				0	0	0
Ped-Bike Adj(A_pbT)	1.00		0.98	1.00		1.00				1.00		1.00
Parking Bus, Adj	1.00	1.00	1.00	1.00	1.00	1.00				1.00	1.00	1.00
Work Zone On Approach		No			No						No	
Adj Sat Flow, veh/h/ln	0	1870	1870	1870	1870	0				1870	1870	1870
Adj Flow Rate, veh/h	0	567	432	507	852	0				208	121	0
Peak Hour Factor	0.97	0.97	0.97	0.96	0.96	0.96				0.72	0.72	0.72
Percent Heavy Veh, %	0	2	2	2	2	0				2	2	2
Cap, veh/h	0	1416	619	472	2587	0				255	268	
Arrive On Green	0.00	0.40	0.40	0.27	0.73	0.00				0.14	0.14	0.00
Sat Flow, veh/h	0	3647	1555	1781	3647	0				1781	1870	0
Grp Volume(v), veh/h	0	567	432	507	852	0				208	121	0
Grp Sat Flow(s),veh/h/ln	0	1777	1555	1781	1777	0				1781	1870	0
Q Serve(g_s), s	0.0	8.0	16.2	18.5	6.0	0.0				7.9	4.1	0.0
Cycle Q Clear(g_c), s	0.0	8.0	16.2	18.5	6.0	0.0				7.9	4.1	0.0
Prop In Lane	0.00		1.00	1.00		0.00				1.00		0.00
Lane Grp Cap(c), veh/h	0	1416	619	472	2587	0				255	268	
V/C Ratio(X)	0.00	0.40	0.70	1.07	0.33	0.00				0.82	0.45	
Avail Cap(c_a), veh/h	0	1416	619	472	2587	0				260	273	
HCM Platoon Ratio	1.00	1.00	1.00	1.00	1.00	1.00				1.00	1.00	1.00
Upstream Filter(I)	0.00	1.00	1.00	1.00	1.00	0.00				1.00	1.00	0.00
Uniform Delay (d), s/veh	0.0	15.0	17.5	25.6	3.4	0.0				29.0	27.4	0.0
Incr Delay (d2), s/veh	0.0	0.8	6.4	62.6	0.3	0.0				17.7	1.2	0.0
Initial Q Delay(d3),s/veh	0.0	0.0	0.0	0.0	0.0	0.0				0.0	0.0	0.0
%ile BackOfQ(50%),veh/ln	0.0	3.0	6.2	15.4	1.3	0.0				4.5	1.9	0.0
Unsig. Movement Delay, s/veh												
LnGrp Delay(d),s/veh	0.0	15.9	23.9	88.2	3.7	0.0				46.7	28.6	0.0
LnGrp LOS	A	B	C	F	A	A				D	C	
Approach Vol, veh/h		999			1359						329	
Approach Delay, s/veh		19.3			35.2						40.0	
Approach LOS		B			D						D	
Timer - Assigned Phs		2			5	6		8				
Phs Duration (G+Y+Rc), s		55.3			23.0	32.3		14.5				
Change Period (Y+Rc), s		4.5			4.5	4.5		4.5				
Max Green Setting (Gmax), s		50.8			18.5	27.8		10.2				
Max Q Clear Time (g_c+I1), s		8.0			20.5	18.2		9.9				
Green Ext Time (p_c), s		7.0			0.0	3.8		0.0				
<b>Intersection Summary</b>												
HCM 6th Ctrl Delay				29.9								
HCM 6th LOS				C								
<b>Notes</b>												
User approved volume balancing among the lanes for turning movement.												
User approved ignoring U-Turning movement.												
Unsignalized Delay for [SBR] is excluded from calculations of the approach delay and intersection delay.												

Queues  
1: Old Redwood Hwy & Shiloh Road

2028 Opening Year Alter. B Project Conditions  
Timing Plan: A.M. PEAK



Lane Group	EBL	EBT	EBR	WBT	WBR	NBL	NBT	NBR	SBL	SBT	SBR
Lane Group Flow (vph)	169	358	167	230	31	129	157	42	44	316	245
v/c Ratio	0.37	0.74	0.34	0.66	0.08	0.57	0.26	0.07	0.39	0.71	0.52
Control Delay	35.1	45.7	15.8	48.6	0.4	55.6	27.8	1.5	61.6	45.2	20.4
Queue Delay	0.0	0.0	0.0	0.0	0.0	0.0	0.0	0.0	0.0	0.0	0.0
Total Delay	35.1	45.7	15.8	48.6	0.4	55.6	27.8	1.5	61.6	45.2	20.4
Queue Length 50th (ft)	86	205	29	137	0	78	75	0	28	186	59
Queue Length 95th (ft)	161	336	82	248	0	#169	143	6	#75	297	135
Internal Link Dist (ft)		1709		528			668			695	
Turn Bay Length (ft)	375		140		50	200		98	130		93
Base Capacity (vph)	589	620	597	768	717	280	884	792	116	711	673
Starvation Cap Reductn	0	0	0	0	0	0	0	0	0	0	0
Spillback Cap Reductn	0	0	0	0	0	0	0	0	0	0	0
Storage Cap Reductn	0	0	0	0	0	0	0	0	0	0	0
Reduced v/c Ratio	0.29	0.58	0.28	0.30	0.04	0.46	0.18	0.05	0.38	0.44	0.36

Intersection Summary

# 95th percentile volume exceeds capacity, queue may be longer.  
Queue shown is maximum after two cycles.



Queues  
2: Shiloh Road & Hembree Ln

2028 Opening Year Alter. B Project Conditions  
Timing Plan: A.M. PEAK

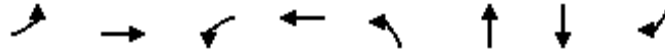

Lane Group	EBL	EBT	WBL	WBT	NBL	NBT	SBT	SBR
Lane Group Flow (vph)	394	619	19	565	39	18	95	439
v/c Ratio	0.52	0.57	0.10	0.53	0.20	0.09	0.34	0.52
Control Delay	25.4	11.3	34.1	17.7	34.8	24.3	31.5	6.7
Queue Delay	0.0	0.0	0.0	0.0	0.0	0.0	0.0	0.0
Total Delay	25.4	11.3	34.1	17.7	34.8	24.3	31.5	6.7
Queue Length 50th (ft)	64	135	6	87	13	2	31	18
Queue Length 95th (ft)	144	286	32	137	53	25	98	112
Internal Link Dist (ft)		222		1709		136	301	
Turn Bay Length (ft)			100					
Base Capacity (vph)	1146	1597	191	2648	191	192	350	981
Starvation Cap Reductn	0	0	0	0	0	0	0	0
Spillback Cap Reductn	0	0	0	0	0	0	0	0
Storage Cap Reductn	0	0	0	0	0	0	0	0
Reduced v/c Ratio	0.34	0.39	0.10	0.21	0.20	0.09	0.27	0.45
Intersection Summary								

Queues  
3: US 101 NB Off-Ramp & Shiloh Road

2028 Opening Year Alter. B Project Conditions  
Timing Plan: A.M. PEAK

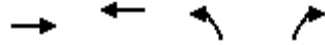

Lane Group	EBT	WBT	NBL	NBR
Lane Group Flow (vph)	395	790	647	728
v/c Ratio	0.24	0.92	0.87	0.48
Control Delay	11.9	36.2	33.6	3.4
Queue Delay	0.0	0.0	0.0	0.0
Total Delay	11.9	36.2	33.6	3.4
Queue Length 50th (ft)	53	315	248	14
Queue Length 95th (ft)	81	#546	293	23
Internal Link Dist (ft)	106	291	689	
Turn Bay Length (ft)				265
Base Capacity (vph)	1756	924	825	1635
Starvation Cap Reductn	0	0	0	0
Spillback Cap Reductn	0	0	0	0
Storage Cap Reductn	0	0	0	0
Reduced v/c Ratio	0.22	0.85	0.78	0.45

Intersection Summary

# 95th percentile volume exceeds capacity, queue may be longer.  
Queue shown is maximum after two cycles.

Queues  
4: Shiloh Road & US 101 SB Off-Ramp

2028 Opening Year Alter. B Project Conditions  
Timing Plan: A.M. PEAK

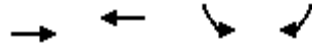

Lane Group	EBT	WBT	SBL	SBR
Lane Group Flow (vph)	302	754	175	189
v/c Ratio	0.29	0.71	0.43	0.37
Control Delay	5.5	11.1	20.1	6.0
Queue Delay	0.0	0.0	0.0	0.0
Total Delay	5.5	11.1	20.1	6.0
Queue Length 50th (ft)	29	101	35	0
Queue Length 95th (ft)	73	246	105	43
Internal Link Dist (ft)	145	226	406	
Turn Bay Length (ft)				275
Base Capacity (vph)	1863	1863	750	780
Starvation Cap Reductn	0	0	0	0
Spillback Cap Reductn	0	0	0	0
Storage Cap Reductn	0	0	0	0
Reduced v/c Ratio	0.16	0.40	0.23	0.24
<b>Intersection Summary</b>				

Queues  
6: Conde Lane & Shiloh Road

2028 Opening Year Alter. B Project Conditions  
Timing Plan: A.M. PEAK

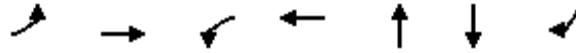

Lane Group	EBL	EBT	WBL	WBT	NBT	SBT	SBR
Lane Group Flow (vph)	29	408	12	755	34	272	47
v/c Ratio	0.08	0.28	0.03	0.56	0.07	0.57	0.08
Control Delay	25.6	10.6	25.9	13.1	0.3	30.3	13.2
Queue Delay	0.0	0.0	0.0	0.0	0.0	0.0	0.0
Total Delay	25.6	10.6	25.9	13.1	0.3	30.3	13.2
Queue Length 50th (ft)	5	22	2	37	0	47	4
Queue Length 95th (ft)	35	98	18	155	0	#248	32
Internal Link Dist (ft)		735		1001	338	442	
Turn Bay Length (ft)	90		127				40
Base Capacity (vph)	392	2974	348	2818	1285	480	1323
Starvation Cap Reductn	0	0	0	0	0	0	0
Spillback Cap Reductn	0	0	0	0	0	0	0
Storage Cap Reductn	0	0	0	0	0	0	0
Reduced v/c Ratio	0.07	0.14	0.03	0.27	0.03	0.57	0.04

Intersection Summary

# 95th percentile volume exceeds capacity, queue may be longer.  
Queue shown is maximum after two cycles.

Queues

2028 Opening Year Alter. B Project Conditions

10: US 101 NB Off Ramp/Lakewood Drive & Old Redwood Highway

Timing Plan: A.M. PEAK



Lane Group	EBL	EBT	WBT	NBL	NBT	SBL	SBR
Lane Group Flow (vph)	204	233	832	221	446	151	683
v/c Ratio	0.54	0.24	0.68	0.61	0.59	0.50	0.86
Control Delay	40.3	12.8	24.9	34.9	27.7	41.8	25.1
Queue Delay	0.0	0.0	0.0	0.0	0.0	0.0	0.0
Total Delay	40.3	12.8	24.9	34.9	27.7	41.8	25.1
Queue Length 50th (ft)	49	60	170	107	97	37	185
Queue Length 95th (ft)	86	117	244	181	143	72	335
Internal Link Dist (ft)		146	537		636		
Turn Bay Length (ft)	155			270		120	
Base Capacity (vph)	393	952	1225	594	1222	305	797
Starvation Cap Reductn	0	0	0	0	0	0	0
Spillback Cap Reductn	0	0	0	0	0	0	0
Storage Cap Reductn	0	0	0	0	0	0	0
Reduced v/c Ratio	0.52	0.24	0.68	0.37	0.36	0.50	0.86

Intersection Summary

Queues

12: US 101 SB On Ramp/US 101 SB Off Ramp & Old Redwood Highway



Lane Group	EBT	EBR	WBL	WBT	SBL	SBT
Lane Group Flow (vph)	368	366	656	645	133	123
v/c Ratio	0.31	0.48	1.02	0.24	0.63	0.45
Control Delay	20.3	5.2	69.4	3.2	48.4	17.6
Queue Delay	0.0	0.0	0.0	0.0	0.0	0.0
Total Delay	20.3	5.2	69.4	3.2	48.4	17.6
Queue Length 50th (ft)	70	5	~338	40	67	15
Queue Length 95th (ft)	104	62	#544	54	#113	53
Internal Link Dist (ft)	343			451		751
Turn Bay Length (ft)			250		420	
Base Capacity (vph)	1203	760	641	2663	210	273
Starvation Cap Reductn	0	0	0	0	0	0
Spillback Cap Reductn	0	0	0	0	0	0
Storage Cap Reductn	0	0	0	0	0	0
Reduced v/c Ratio	0.31	0.48	1.02	0.24	0.63	0.45

Intersection Summary

~ Volume exceeds capacity, queue is theoretically infinite.

Queue shown is maximum after two cycles.

# 95th percentile volume exceeds capacity, queue may be longer.

Queue shown is maximum after two cycles.

Queues  
1: Old Redwood Hwy & Shiloh Road

2028 Opening Year Alter. B Project Conditions

Timing Plan: P.M. Peak



Lane Group	EBL	EBT	EBR	WBT	WBR	NBL	NBT	NBR	SBL	SBT	SBR
Lane Group Flow (vph)	265	370	257	408	54	242	373	23	63	265	175
v/c Ratio	0.61	0.80	0.50	0.83	0.11	1.02	0.73	0.05	0.64	0.73	0.45
Control Delay	46.1	55.5	19.4	54.9	0.4	114.7	47.3	0.2	85.8	55.6	20.0
Queue Delay	0.0	0.0	0.0	0.0	0.0	0.0	0.0	0.0	0.0	0.0	0.0
Total Delay	46.1	55.5	19.4	54.9	0.4	114.7	47.3	0.2	85.8	55.6	20.0
Queue Length 50th (ft)	168	249	57	283	0	~199	253	0	46	186	39
Queue Length 95th (ft)	307	#478	161	448	0	#431	390	0	#139	296	110
Internal Link Dist (ft)		1709		528			668			695	
Turn Bay Length (ft)	375		140		50	200		98	130		93
Base Capacity (vph)	498	525	559	651	612	237	749	667	98	602	574
Starvation Cap Reductn	0	0	0	0	0	0	0	0	0	0	0
Spillback Cap Reductn	0	0	0	0	0	0	0	0	0	0	0
Storage Cap Reductn	0	0	0	0	0	0	0	0	0	0	0
Reduced v/c Ratio	0.53	0.70	0.46	0.63	0.09	1.02	0.50	0.03	0.64	0.44	0.30

Intersection Summary

~ Volume exceeds capacity, queue is theoretically infinite.

Queue shown is maximum after two cycles.

# 95th percentile volume exceeds capacity, queue may be longer.

Queue shown is maximum after two cycles.

Queues

2028 Opening Year Alter. B Project Conditions

2: Shiloh Road & Hembree Ln

Timing Plan: P.M. Peak

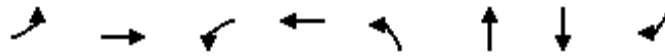

Lane Group	EBL	EBT	WBL	WBT	NBL	NBT	SBT	SBR
Lane Group Flow (vph)	654	815	24	858	65	26	190	523
v/c Ratio	0.80	0.73	0.18	0.68	0.48	0.18	0.77	0.73
Control Delay	38.9	16.2	40.5	21.7	50.6	27.3	57.0	20.1
Queue Delay	0.0	0.0	0.0	0.0	0.0	0.0	0.0	0.0
Total Delay	38.9	16.3	40.5	21.7	50.6	27.3	57.0	20.1
Queue Length 50th (ft)	141	217	10	167	28	5	83	85
Queue Length 95th (ft)	#310	467	39	212	#96	32	#240	#369
Internal Link Dist (ft)		222		1709		136	301	
Turn Bay Length (ft)			100					
Base Capacity (vph)	814	1369	136	2004	136	144	248	720
Starvation Cap Reductn	0	24	0	0	0	0	0	0
Spillback Cap Reductn	0	0	0	0	0	0	0	0
Storage Cap Reductn	0	0	0	0	0	0	0	0
Reduced v/c Ratio	0.80	0.61	0.18	0.43	0.48	0.18	0.77	0.73

Intersection Summary

# 95th percentile volume exceeds capacity, queue may be longer.  
 Queue shown is maximum after two cycles.



Queues  
3: US 101 NB Off-Ramp & Shiloh Road

2028 Opening Year Alter. B Project Conditions  
Timing Plan: P.M. Peak

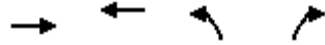

Lane Group	EBT	WBT	NBL	NBR
Lane Group Flow (vph)	554	830	584	963
v/c Ratio	0.33	0.94	0.82	0.71
Control Delay	12.3	38.4	28.8	12.6
Queue Delay	0.0	0.0	0.0	0.0
Total Delay	12.3	38.4	28.8	12.6
Queue Length 50th (ft)	79	344	212	105
Queue Length 95th (ft)	113	#588	#352	176
Internal Link Dist (ft)	106	291	689	
Turn Bay Length (ft)				265
Base Capacity (vph)	1737	914	816	1498
Starvation Cap Reductn	0	0	0	0
Spillback Cap Reductn	0	0	0	0
Storage Cap Reductn	0	0	0	0
Reduced v/c Ratio	0.32	0.91	0.72	0.64

Intersection Summary

# 95th percentile volume exceeds capacity, queue may be longer.  
Queue shown is maximum after two cycles.

Queues  
4: Shiloh Road & US 101 SB Off-Ramp

2028 Opening Year Alter. B Project Conditions  
Timing Plan: P.M. Peak

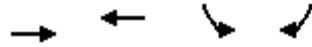

Lane Group	EBT	WBT	SBL	SBR
Lane Group Flow (vph)	518	677	253	141
v/c Ratio	0.53	0.70	0.51	0.26
Control Delay	9.2	12.3	18.7	5.0
Queue Delay	0.0	0.0	0.0	0.0
Total Delay	9.2	12.3	18.7	5.0
Queue Length 50th (ft)	68	100	50	0
Queue Length 95th (ft)	156	236	132	33
Internal Link Dist (ft)	145	226	406	
Turn Bay Length (ft)				275
Base Capacity (vph)	1863	1863	744	732
Starvation Cap Reductn	0	0	0	0
Spillback Cap Reductn	0	0	0	0
Storage Cap Reductn	0	0	0	0
Reduced v/c Ratio	0.28	0.36	0.34	0.19
<b>Intersection Summary</b>				

Queues  
6: Conde Lane & Shiloh Road

2028 Opening Year Alter. B Project Conditions  
Timing Plan: P.M. Peak

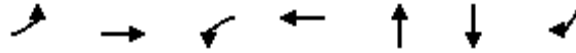

Lane Group	EBL	EBT	WBL	WBT	NBT	SBT	SBR
Lane Group Flow (vph)	78	561	9	957	40	338	44
v/c Ratio	0.29	0.31	0.03	0.70	0.12	0.95	0.07
Control Delay	33.5	10.3	32.1	17.6	17.8	72.3	14.3
Queue Delay	0.0	0.0	0.0	0.0	0.0	0.0	0.0
Total Delay	33.5	10.3	32.1	17.6	17.8	72.3	14.3
Queue Length 50th (ft)	32	65	4	164	5	~188	13
Queue Length 95th (ft)	78	129	16	187	20	#381	31
Internal Link Dist (ft)		735		1001	338	442	
Turn Bay Length (ft)	90		127				40
Base Capacity (vph)	292	2484	259	2326	1007	357	1093
Starvation Cap Reductn	0	0	0	0	0	0	0
Spillback Cap Reductn	0	0	0	0	0	0	0
Storage Cap Reductn	0	0	0	0	0	0	0
Reduced v/c Ratio	0.27	0.23	0.03	0.41	0.04	0.95	0.04

Intersection Summary

~ Volume exceeds capacity, queue is theoretically infinite.

Queue shown is maximum after two cycles.

# 95th percentile volume exceeds capacity, queue may be longer.

Queue shown is maximum after two cycles.

Queues

10: US 101 NB Off Ramp/Lakewood Drive & Old Redwood Highway



Lane Group	EBL	EBT	WBT	NBL	NBT	SBL	SBR
Lane Group Flow (vph)	300	454	802	424	840	259	601
v/c Ratio	0.86	0.54	0.74	0.85	0.80	0.95	0.68
Control Delay	64.1	20.8	30.8	46.2	31.9	87.1	13.4
Queue Delay	0.0	0.0	0.0	0.0	0.0	0.0	0.0
Total Delay	64.1	20.8	30.8	46.2	31.9	87.1	13.4
Queue Length 50th (ft)	88	183	201	241	212	77	127
Queue Length 95th (ft)	#151	262	271	#413	290	#153	247
Internal Link Dist (ft)		146	537		636		
Turn Bay Length (ft)	155			270		120	
Base Capacity (vph)	349	847	1079	527	1100	272	889
Starvation Cap Reductn	0	0	0	0	0	0	0
Spillback Cap Reductn	0	0	0	0	0	0	0
Storage Cap Reductn	0	0	0	0	0	0	0
Reduced v/c Ratio	0.86	0.54	0.74	0.80	0.76	0.95	0.68

Intersection Summary

# 95th percentile volume exceeds capacity, queue may be longer.  
 Queue shown is maximum after two cycles.

Queues

12: US 101 SB On Ramp/US 101 SB Off Ramp & Old Redwood Highway



Lane Group	EBT	EBR	WBL	WBT	SBL	SBT
Lane Group Flow (vph)	569	405	428	1151	214	196
v/c Ratio	0.40	0.47	0.94	0.46	0.87	0.59
Control Delay	16.2	3.7	58.2	5.0	63.8	20.1
Queue Delay	0.0	0.0	0.0	0.0	0.0	0.0
Total Delay	16.2	3.7	58.2	5.0	63.8	20.1
Queue Length 50th (ft)	89	0	180	87	96	30
Queue Length 95th (ft)	128	49	#340	116	#190	81
Internal Link Dist (ft)	343			451		751
Turn Bay Length (ft)			250		420	
Base Capacity (vph)	1410	864	455	2522	247	330
Starvation Cap Reductn	0	0	0	0	0	0
Spillback Cap Reductn	0	0	0	0	0	0
Storage Cap Reductn	0	0	0	0	0	0
Reduced v/c Ratio	0.40	0.47	0.94	0.46	0.87	0.59

Intersection Summary

# 95th percentile volume exceeds capacity, queue may be longer.  
 Queue shown is maximum after two cycles.

Queues  
1: Old Redwood Hwy & Shiloh Road

2028 Opening Year Alter. B Project Conditions

Timing Plan: Saturday Midday Peak



Lane Group	EBL	EBT	EBR	WBT	WBR	NBL	NBT	NBR	SBL	SBT	SBR
Lane Group Flow (vph)	175	509	317	595	81	315	300	29	78	251	263
v/c Ratio	0.40	1.09	0.64	1.03	0.14	1.55	0.65	0.06	0.99	0.75	0.62
Control Delay	42.7	112.7	29.7	86.9	2.9	307.9	47.6	0.3	155.5	61.5	21.8
Queue Delay	0.0	0.0	0.0	0.0	0.0	0.0	0.0	0.0	0.0	0.0	0.0
Total Delay	42.7	112.7	29.7	86.9	2.9	307.9	47.6	0.3	155.5	61.5	21.8
Queue Length 50th (ft)	115	~449	122	~496	0	~347	212	0	62	189	59
Queue Length 95th (ft)	199	#728	242	#752	14	#580	307	0	#181	279	148
Internal Link Dist (ft)		1709		528			668			695	
Turn Bay Length (ft)	375		140		50	200		98	130		93
Base Capacity (vph)	442	466	493	579	571	203	664	605	79	534	568
Starvation Cap Reductn	0	0	0	0	0	0	0	0	0	0	0
Spillback Cap Reductn	0	0	0	0	0	0	0	0	0	0	0
Storage Cap Reductn	0	0	0	0	0	0	0	0	0	0	0
Reduced v/c Ratio	0.40	1.09	0.64	1.03	0.14	1.55	0.45	0.05	0.99	0.47	0.46

Intersection Summary

~ Volume exceeds capacity, queue is theoretically infinite.

Queue shown is maximum after two cycles.

# 95th percentile volume exceeds capacity, queue may be longer.

Queue shown is maximum after two cycles.

Queues  
2: Shiloh Road & Hembree Ln

2028 Opening Year Alter. B Project Conditions

Timing Plan: Saturday Midday Peak

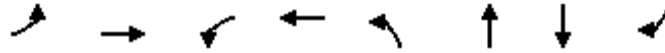

Lane Group	EBL	EBT	WBL	WBT	NBL	NBT	SBT	SBR
Lane Group Flow (vph)	753	910	24	1002	65	26	211	732
v/c Ratio	0.98	0.78	0.19	0.73	0.51	0.19	0.90	1.10
Control Delay	61.4	18.5	42.4	22.5	54.2	28.4	77.2	87.5
Queue Delay	0.0	0.2	0.0	0.0	0.0	0.0	0.0	0.0
Total Delay	61.4	18.7	42.4	22.5	54.2	28.4	77.2	87.5
Queue Length 50th (ft)	186	266	11	209	31	5	102	~326
Queue Length 95th (ft)	#375	#601	39	274	#96	32	#272	#720
Internal Link Dist (ft)		222		1709		136	301	
Turn Bay Length (ft)			100					
Base Capacity (vph)	771	1298	128	1900	128	137	235	666
Starvation Cap Reductn	0	59	0	0	0	0	0	0
Spillback Cap Reductn	0	0	0	0	0	0	0	0
Storage Cap Reductn	0	0	0	0	0	0	0	0
Reduced v/c Ratio	0.98	0.73	0.19	0.53	0.51	0.19	0.90	1.10

Intersection Summary

~ Volume exceeds capacity, queue is theoretically infinite.

Queue shown is maximum after two cycles.

# 95th percentile volume exceeds capacity, queue may be longer.

Queue shown is maximum after two cycles.

Queues  
3: US 101 NB Off-Ramp & Shiloh Road

2028 Opening Year Alter. B Project Conditions  
Timing Plan: Saturday Midday Peak

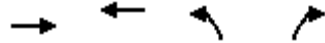

Lane Group	EBT	WBT	NBL	NBR
Lane Group Flow (vph)	624	1105	401	931
v/c Ratio	0.31	1.06	0.72	0.82
Control Delay	10.1	65.6	29.6	19.4
Queue Delay	0.0	0.0	0.0	0.0
Total Delay	10.1	65.6	29.6	19.4
Queue Length 50th (ft)	74	~569	157	127
Queue Length 95th (ft)	128	#901	248	205
Internal Link Dist (ft)	106	291	689	
Turn Bay Length (ft)				265
Base Capacity (vph)	1981	1043	746	1396
Starvation Cap Reductn	0	0	0	0
Spillback Cap Reductn	0	0	0	0
Storage Cap Reductn	0	0	0	0
Reduced v/c Ratio	0.31	1.06	0.54	0.67

Intersection Summary

- ~ Volume exceeds capacity, queue is theoretically infinite.  
Queue shown is maximum after two cycles.
- # 95th percentile volume exceeds capacity, queue may be longer.  
Queue shown is maximum after two cycles.



Queues  
4: Shiloh Road & US 101 SB Off-Ramp

2028 Opening Year Alter. B Project Conditions  
Timing Plan: Saturday Midday Peak

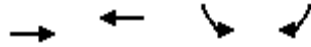

Lane Group	EBT	WBT	SBL	SBR
Lane Group Flow (vph)	363	659	535	256
v/c Ratio	0.42	0.77	0.87	0.36
Control Delay	9.9	17.2	36.3	4.3
Queue Delay	0.0	0.0	0.0	0.0
Total Delay	9.9	17.2	36.3	4.3
Queue Length 50th (ft)	61	138	132	0
Queue Length 95th (ft)	106	233	#233	15
Internal Link Dist (ft)	145	226	406	
Turn Bay Length (ft)				275
Base Capacity (vph)	1863	1863	616	718
Starvation Cap Reductn	0	0	0	0
Spillback Cap Reductn	0	0	0	0
Storage Cap Reductn	0	0	0	0
Reduced v/c Ratio	0.19	0.35	0.87	0.36

Intersection Summary

# 95th percentile volume exceeds capacity, queue may be longer.  
Queue shown is maximum after two cycles.

Queues  
6: Conde Lane & Shiloh Road

2028 Opening Year Alter. B Project Conditions  
Timing Plan: Saturday Midday Peak

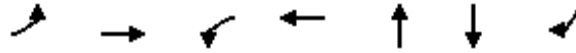

Lane Group	EBL	EBT	WBL	WBT	NBT	SBT	SBR
Lane Group Flow (vph)	34	451	11	784	14	287	41
v/c Ratio	0.10	0.29	0.03	0.58	0.03	0.60	0.07
Control Delay	23.9	9.8	24.5	13.0	0.1	28.8	12.0
Queue Delay	0.0	0.0	0.0	0.0	0.0	0.0	0.0
Total Delay	23.9	9.8	24.5	13.0	0.1	28.8	12.0
Queue Length 50th (ft)	6	26	2	45	0	48	4
Queue Length 95th (ft)	41	113	20	193	0	#247	27
Internal Link Dist (ft)		735		1001	338	442	
Turn Bay Length (ft)	90		127				40
Base Capacity (vph)	369	3083	347	2911	1314	477	1374
Starvation Cap Reductn	0	0	0	0	0	0	0
Spillback Cap Reductn	0	0	0	0	0	0	0
Storage Cap Reductn	0	0	0	0	0	0	0
Reduced v/c Ratio	0.09	0.15	0.03	0.27	0.01	0.60	0.03

Intersection Summary

# 95th percentile volume exceeds capacity, queue may be longer.  
Queue shown is maximum after two cycles.

Queues

2028 Opening Year Alter. B Project Conditions

10: US 101 NB Off Ramp/Lakewood Drive & Old Redwood Highway Timing Plan: Saturday Midday Peak



Lane Group	EBL	EBT	WBT	NBL	NBT	SBL	SBR
Lane Group Flow (vph)	302	394	949	262	519	277	795
v/c Ratio	0.96	0.42	0.76	0.66	0.61	0.94	1.01
Control Delay	81.7	16.0	27.0	35.6	26.8	80.3	50.9
Queue Delay	0.0	0.0	0.0	0.0	0.0	0.0	0.0
Total Delay	81.7	16.0	27.0	35.6	26.8	80.3	50.9
Queue Length 50th (ft)	81	123	203	131	113	74	293
Queue Length 95th (ft)	#180	231	314	215	163	#162	#537
Internal Link Dist (ft)		146	537		636		
Turn Bay Length (ft)	155			270		120	
Base Capacity (vph)	315	932	1244	576	1191	294	790
Starvation Cap Reductn	0	0	0	0	0	0	0
Spillback Cap Reductn	0	0	0	0	0	0	0
Storage Cap Reductn	0	0	0	0	0	0	0
Reduced v/c Ratio	0.96	0.42	0.76	0.45	0.44	0.94	1.01

Intersection Summary

# 95th percentile volume exceeds capacity, queue may be longer.  
 Queue shown is maximum after two cycles.

Queues

2028 Opening Year Alter. B Project Conditions

12: US 101 SB On Ramp/US 101 SB Off Ramp & Old Redwood Highway Timing Plan: Saturday Midday Peak



Lane Group	EBT	EBR	WBL	WBT	SBL	SBT
Lane Group Flow (vph)	567	432	507	852	215	201
v/c Ratio	0.40	0.49	1.09	0.33	0.88	0.65
Control Delay	16.2	3.8	95.1	3.9	66.6	27.4
Queue Delay	0.0	0.0	0.0	0.0	0.0	0.0
Total Delay	16.2	3.8	95.1	3.9	66.6	27.4
Queue Length 50th (ft)	89	0	~251	54	96	46
Queue Length 95th (ft)	128	50	#424	74	#151	77
Internal Link Dist (ft)	343			451		751
Turn Bay Length (ft)			250		420	
Base Capacity (vph)	1405	877	467	2568	244	307
Starvation Cap Reductn	0	0	0	0	0	0
Spillback Cap Reductn	0	0	0	0	0	0
Storage Cap Reductn	0	0	0	0	0	0
Reduced v/c Ratio	0.40	0.49	1.09	0.33	0.88	0.65

Intersection Summary

























~ Volume exceeds capacity, queue is theoretically infinite.

Queue shown is maximum after two cycles.

























# 95th percentile volume exceeds capacity, queue may be longer.

Queue shown is maximum after two cycles.

HCM 6th Signalized Intersection Sun 2026 Opening Year Alter. B Project Conditions Mitigations  
 1: Old Redwood Hwy & Shiloh Road Timing Plan: A.M. PEAK

























												
Movement	EBL	EBT	EBR	WBL	WBT	WBR	NBL	NBT	NBR	SBL	SBT	SBR
Lane Configurations												
Traffic Volume (veh/h)	137	290	135	25	180	28	120	146	39	37	269	208
Future Volume (veh/h)	137	290	135	25	180	28	120	146	39	37	269	208
Initial Q (Qb), veh	0	0	0	0	0	0	0	0	0	0	0	0
Ped-Bike Adj(A_pbT)	1.00		1.00	1.00		1.00	1.00		1.00	1.00		0.99
Parking Bus, Adj	1.00	1.00	1.00	1.00	1.00	1.00	1.00	1.00	1.00	1.00	1.00	1.00
Work Zone On Approach		No			No			No			No	
Adj Sat Flow, veh/h/ln	1870	1870	1870	1870	1870	1870	1870	1870	1870	1870	1870	1870
Adj Flow Rate, veh/h	169	358	167	28	202	31	129	157	42	44	316	245
Peak Hour Factor	0.81	0.81	0.81	0.89	0.89	0.89	0.93	0.93	0.93	0.85	0.85	0.85
Percent Heavy Veh, %	2	2	2	2	2	2	2	2	2	2	2	2
Cap, veh/h	456	478	405	274	287	244	282	432	366	146	433	362
Arrive On Green	0.26	0.26	0.26	0.15	0.15	0.15	0.08	0.23	0.23	0.08	0.23	0.23
Sat Flow, veh/h	1781	1870	1585	1781	1870	1585	3456	1870	1585	1781	1870	1565
Grp Volume(v), veh/h	169	358	167	28	202	31	129	157	42	44	316	245
Grp Sat Flow(s),veh/h/ln	1781	1870	1585	1781	1870	1585	1728	1870	1585	1781	1870	1565
Q Serve(g_s), s	4.8	10.8	5.4	0.8	6.3	1.0	2.2	4.3	1.3	1.4	9.6	8.7
Cycle Q Clear(g_c), s	4.8	10.8	5.4	0.8	6.3	1.0	2.2	4.3	1.3	1.4	9.6	8.7
Prop In Lane	1.00		1.00	1.00		1.00	1.00		1.00	1.00		1.00
Lane Grp Cap(c), veh/h	456	478	405	274	287	244	282	432	366	146	433	362
V/C Ratio(X)	0.37	0.75	0.41	0.10	0.70	0.13	0.46	0.36	0.11	0.30	0.73	0.68
Avail Cap(c_a), veh/h	888	932	790	1106	1161	984	819	1329	1126	175	1069	895
HCM Platoon Ratio	1.00	1.00	1.00	1.00	1.00	1.00	1.00	1.00	1.00	1.00	1.00	1.00
Upstream Filter(I)	1.00	1.00	1.00	1.00	1.00	1.00	1.00	1.00	1.00	1.00	1.00	1.00
Uniform Delay (d), s/veh	18.7	21.0	18.9	22.3	24.6	22.4	26.8	19.8	18.6	26.5	21.8	21.4
Incr Delay (d2), s/veh	0.5	2.4	0.7	0.2	3.1	0.2	1.2	0.5	0.1	1.2	2.4	2.2
Initial Q Delay(d3),s/veh	0.0	0.0	0.0	0.0	0.0	0.0	0.0	0.0	0.0	0.0	0.0	0.0
%ile BackOfQ(50%),veh/ln	1.8	4.4	1.8	0.3	2.8	0.4	0.9	1.7	0.4	0.6	4.0	3.0
Unsig. Movement Delay, s/veh												
LnGrp Delay(d),s/veh	19.2	23.3	19.6	22.4	27.7	22.6	28.0	20.3	18.7	27.6	24.2	23.7
LnGrp LOS	B	C	B	C	C	C	C	C	B	C	C	C
Approach Vol, veh/h		694			261			328			605	
Approach Delay, s/veh		21.4			26.5			23.1			24.2	
Approach LOS		C			C			C			C	
Timer - Assigned Phs		2	3	4		6	7	8				
Phs Duration (G+Y+Rc), s		20.2	8.5	18.7		13.9	8.5	18.6				
Change Period (Y+Rc), s		4.5	3.5	4.5		4.5	3.5	4.5				
Max Green Setting (Gmax), s		30.5	14.5	35.0		38.0	6.0	43.5				
Max Q Clear Time (g_c+I1), s		12.8	4.2	11.6		8.3	3.4	6.3				
Green Ext Time (p_c), s		2.9	0.2	2.6		1.2	0.0	0.9				
<b>Intersection Summary</b>												
HCM 6th Ctrl Delay				23.3								
HCM 6th LOS				C								

HCM 6th Signalized Intersection Sun 2026 Opening Year Alter. B Project Conditions Mitigations  
 1: Old Redwood Hwy & Shiloh Road Timing Plan: P.M. Peak

												
Movement	EBL	EBT	EBR	WBL	WBT	WBR	NBL	NBT	NBR	SBL	SBT	SBR
Lane Configurations												
Traffic Volume (veh/h)	257	359	249	37	334	49	225	347	21	59	246	163
Future Volume (veh/h)	257	359	249	37	334	49	225	347	21	59	246	163
Initial Q (Qb), veh	0	0	0	0	0	0	0	0	0	0	0	0
Ped-Bike Adj(A_pbT)	1.00		1.00	1.00		1.00	1.00		0.97	1.00		0.98
Parking Bus, Adj	1.00	1.00	1.00	1.00	1.00	1.00	1.00	1.00	1.00	1.00	1.00	1.00
Work Zone On Approach		No			No			No			No	
Adj Sat Flow, veh/h/ln	1870	1870	1870	1870	1870	1870	1870	1870	1870	1870	1870	1870
Adj Flow Rate, veh/h	265	370	257	41	367	54	242	373	23	63	265	175
Peak Hour Factor	0.97	0.97	0.97	0.91	0.91	0.91	0.93	0.93	0.93	0.93	0.93	0.93
Percent Heavy Veh, %	2	2	2	2	2	2	2	2	2	2	2	2
Cap, veh/h	445	467	395	427	448	379	336	457	377	108	388	323
Arrive On Green	0.25	0.25	0.25	0.24	0.24	0.24	0.10	0.24	0.24	0.06	0.21	0.21
Sat Flow, veh/h	1781	1870	1582	1781	1870	1582	3456	1870	1543	1781	1870	1559
Grp Volume(v), veh/h	265	370	257	41	367	54	242	373	23	63	265	175
Grp Sat Flow(s),veh/h/ln	1781	1870	1582	1781	1870	1582	1728	1870	1543	1781	1870	1559
Q Serve(g_s), s	10.8	15.3	12.0	1.5	15.3	2.2	5.6	15.6	0.9	2.8	10.8	8.3
Cycle Q Clear(g_c), s	10.8	15.3	12.0	1.5	15.3	2.2	5.6	15.6	0.9	2.8	10.8	8.3
Prop In Lane	1.00		1.00	1.00		1.00	1.00		1.00	1.00		1.00
Lane Grp Cap(c), veh/h	445	467	395	427	448	379	336	457	377	108	388	323
V/C Ratio(X)	0.60	0.79	0.65	0.10	0.82	0.14	0.72	0.82	0.06	0.58	0.68	0.54
Avail Cap(c_a), veh/h	657	690	584	819	860	727	606	984	812	129	792	660
HCM Platoon Ratio	1.00	1.00	1.00	1.00	1.00	1.00	1.00	1.00	1.00	1.00	1.00	1.00
Upstream Filter(I)	1.00	1.00	1.00	1.00	1.00	1.00	1.00	1.00	1.00	1.00	1.00	1.00
Uniform Delay (d), s/veh	27.3	29.0	27.8	24.5	29.7	24.7	36.2	29.5	24.0	37.8	30.2	29.2
Incr Delay (d2), s/veh	1.3	3.8	1.8	0.1	3.7	0.2	2.9	3.6	0.1	5.0	2.1	1.4
Initial Q Delay(d3),s/veh	0.0	0.0	0.0	0.0	0.0	0.0	0.0	0.0	0.0	0.0	0.0	0.0
%ile BackOfQ(50%),veh/ln	4.5	6.9	4.4	0.6	6.9	0.8	2.4	6.9	0.3	1.3	4.8	3.1
Unsig. Movement Delay, s/veh												
LnGrp Delay(d),s/veh	28.6	32.8	29.6	24.5	33.5	24.9	39.1	33.1	24.0	42.8	32.4	30.7
LnGrp LOS	C	C	C	C	C	C	D	C	C	D	C	C
Approach Vol, veh/h		892			462			638			503	
Approach Delay, s/veh		30.7			31.7			35.1			33.1	
Approach LOS		C			C			D			C	
Timer - Assigned Phs		2	3	4		6	7	8				
Phs Duration (G+Y+Rc), s		25.1	11.5	21.7		24.3	8.5	24.7				
Change Period (Y+Rc), s		4.5	3.5	4.5		4.5	3.5	4.5				
Max Green Setting (Gmax), s		30.5	14.5	35.0		38.0	6.0	43.5				
Max Q Clear Time (g_c+I1), s		17.3	7.6	12.8		17.3	4.8	17.6				
Green Ext Time (p_c), s		3.2	0.4	2.0		2.3	0.0	2.1				
<b>Intersection Summary</b>												
HCM 6th Ctrl Delay				32.5								
HCM 6th LOS				C								



















HCM 6th Signalized Intersection Sun 2026 Opening Year Alter. B Project Conditions Mitigations  
 1: Old Redwood Hwy & Shiloh Road

Timing Plan: Saturday Midday Peak

												
Movement	EBL	EBT	EBR	WBL	WBT	WBR	NBL	NBT	NBR	SBL	SBT	SBR
Lane Configurations												
Traffic Volume (veh/h)	156	453	282	24	488	70	293	279	27	71	228	239
Future Volume (veh/h)	156	453	282	24	488	70	293	279	27	71	228	239
Initial Q (Qb), veh	0	0	0	0	0	0	0	0	0	0	0	0
Ped-Bike Adj(A_pbT)	1.00		0.97	1.00		1.00	1.00		0.98	1.00		0.98
Parking Bus, Adj	1.00	1.00	1.00	1.00	1.00	1.00	1.00	1.00	1.00	1.00	1.00	1.00
Work Zone On Approach		No			No			No			No	
Adj Sat Flow, veh/h/ln	1870	1870	1870	1870	1870	1870	1870	1870	1870	1870	1870	1870
Adj Flow Rate, veh/h	175	509	317	28	567	81	315	300	29	78	251	263
Peak Hour Factor	0.89	0.89	0.89	0.86	0.86	0.86	0.93	0.93	0.93	0.91	0.91	0.91
Percent Heavy Veh, %	2	2	2	2	2	2	2	2	2	2	2	2
Cap, veh/h	220	775	640	102	652	552	411	489	406	118	390	325
Arrive On Green	0.12	0.41	0.41	0.06	0.35	0.35	0.12	0.26	0.26	0.07	0.21	0.21
Sat Flow, veh/h	1781	1870	1544	1781	1870	1585	3456	1870	1551	1781	1870	1558
Grp Volume(v), veh/h	175	509	317	28	567	81	315	300	29	78	251	263
Grp Sat Flow(s),veh/h/ln	1781	1870	1544	1781	1870	1585	1728	1870	1551	1781	1870	1558
Q Serve(g_s), s	8.3	19.1	13.2	1.3	24.7	3.1	7.7	12.3	1.2	3.7	10.7	14.0
Cycle Q Clear(g_c), s	8.3	19.1	13.2	1.3	24.7	3.1	7.7	12.3	1.2	3.7	10.7	14.0
Prop In Lane	1.00		1.00	1.00		1.00	1.00		1.00	1.00		1.00
Lane Grp Cap(c), veh/h	220	775	640	102	652	552	411	489	406	118	390	325
V/C Ratio(X)	0.80	0.66	0.50	0.27	0.87	0.15	0.77	0.61	0.07	0.66	0.64	0.81
Avail Cap(c_a), veh/h	651	775	640	796	892	756	713	943	782	204	772	643
HCM Platoon Ratio	1.00	1.00	1.00	1.00	1.00	1.00	1.00	1.00	1.00	1.00	1.00	1.00
Upstream Filter(I)	1.00	1.00	1.00	1.00	1.00	1.00	1.00	1.00	1.00	1.00	1.00	1.00
Uniform Delay (d), s/veh	37.2	20.6	18.8	39.4	26.6	19.5	37.3	28.3	24.3	39.8	31.6	32.9
Incr Delay (d2), s/veh	6.5	2.0	0.6	1.4	7.1	0.1	3.0	1.3	0.1	6.2	1.8	4.8
Initial Q Delay(d3),s/veh	0.0	0.0	0.0	0.0	0.0	0.0	0.0	0.0	0.0	0.0	0.0	0.0
%ile BackOfQ(50%),veh/ln	3.9	8.0	4.3	0.6	11.4	1.1	3.3	5.3	0.4	1.8	4.8	5.4
Unsig. Movement Delay, s/veh												
LnGrp Delay(d),s/veh	43.6	22.6	19.4	40.8	33.7	19.6	40.3	29.6	24.3	46.0	33.3	37.7
LnGrp LOS	D	C	B	D	C	B	D	C	C	D	C	D
Approach Vol, veh/h		1001			676			644			592	
Approach Delay, s/veh		25.3			32.3			34.6			36.9	
Approach LOS		C			C			C			D	
Timer - Assigned Phs	1	2	3	4	5	6	7	8				
Phs Duration (G+Y+Rc), s	9.5	40.7	14.4	22.7	15.3	34.9	9.8	27.3				
Change Period (Y+Rc), s	4.5	4.5	4.0	4.5	4.5	4.5	4.0	4.5				
Max Green Setting (Gmax), s	39.0	34.5	18.0	36.0	31.9	41.6	10.0	44.0				
Max Q Clear Time (g_c+I1), s	3.3	21.1	9.7	16.0	10.3	26.7	5.7	14.3				
Green Ext Time (p_c), s	0.0	3.6	0.7	2.2	0.4	3.3	0.0	1.7				
<b>Intersection Summary</b>												
HCM 6th Ctrl Delay			31.3									
HCM 6th LOS			C									

HCM 6th Signalized Intersection Sun 2026 Opening Year Alter. B Project Conditions Mitigations  
 7: Driveway 1/Gridley Drive & Shiloh Road

Timing Plan: Saturday Midday Peak

												
Movement	EBL	EBT	EBR	WBL	WBT	WBR	NBL	NBT	NBR	SBL	SBT	SBR
Lane Configurations												
Traffic Volume (veh/h)	23	436	103	0	450	0	113	0	0	0	0	20
Future Volume (veh/h)	23	436	103	0	450	0	113	0	0	0	0	20
Initial Q (Qb), veh	0	0	0	0	0	0	0	0	0	0	0	0
Ped-Bike Adj(A_pbT)	1.00		0.99	1.00		1.00	1.00		1.00	1.00		1.00
Parking Bus, Adj	1.00	1.00	1.00	1.00	1.00	1.00	1.00	1.00	1.00	1.00	1.00	1.00
Work Zone On Approach		No			No			No			No	
Adj Sat Flow, veh/h/ln	1870	1870	1870	1870	1870	1870	1870	1870	1870	1870	1870	1870
Adj Flow Rate, veh/h	25	469	111	0	511	0	113	0	0	0	0	36
Peak Hour Factor	0.93	0.93	0.93	0.88	0.88	0.88	1.00	1.00	1.00	0.56	0.56	0.56
Percent Heavy Veh, %	2	2	2	2	2	2	2	2	2	2	2	2
Cap, veh/h	129	689	608	0	727	0	614	569	0	0	0	482
Arrive On Green	0.39	0.39	0.39	0.00	0.39	0.00	0.30	0.00	0.00	0.00	0.00	0.30
Sat Flow, veh/h	37	1772	1564	0	1870	0	1372	1870	0	0	0	1585
Grp Volume(v), veh/h	494	0	111	0	511	0	113	0	0	0	0	36
Grp Sat Flow(s),veh/h/ln	1809	0	1564	0	1870	0	1372	1870	0	0	0	1585
Q Serve(g_s), s	0.1	0.0	1.5	0.0	7.6	0.0	2.1	0.0	0.0	0.0	0.0	0.5
Cycle Q Clear(g_c), s	7.6	0.0	1.5	0.0	7.6	0.0	2.6	0.0	0.0	0.0	0.0	0.5
Prop In Lane	0.05		1.00	0.00		0.00	1.00		0.00	0.00		1.00
Lane Grp Cap(c), veh/h	818	0	608	0	727	0	614	569	0	0	0	482
V/C Ratio(X)	0.60	0.00	0.18	0.00	0.70	0.00	0.18	0.00	0.00	0.00	0.00	0.07
Avail Cap(c_a), veh/h	1563	0	1265	0	1513	0	1169	1325	0	0	0	1123
HCM Platoon Ratio	1.00	1.00	1.00	1.00	1.00	1.00	1.00	1.00	1.00	1.00	1.00	1.00
Upstream Filter(I)	1.00	0.00	1.00	0.00	1.00	0.00	1.00	0.00	0.00	0.00	0.00	1.00
Uniform Delay (d), s/veh	8.3	0.0	6.6	0.0	8.5	0.0	9.1	0.0	0.0	0.0	0.0	8.1
Incr Delay (d2), s/veh	0.7	0.0	0.1	0.0	1.3	0.0	0.1	0.0	0.0	0.0	0.0	0.1
Initial Q Delay(d3),s/veh	0.0	0.0	0.0	0.0	0.0	0.0	0.0	0.0	0.0	0.0	0.0	0.0
%ile BackOfQ(50%),veh/ln	1.7	0.0	0.3	0.0	1.8	0.0	0.5	0.0	0.0	0.0	0.0	0.1
Unsig. Movement Delay, s/veh												
LnGrp Delay(d),s/veh	9.1	0.0	6.8	0.0	9.7	0.0	9.2	0.0	0.0	0.0	0.0	8.2
LnGrp LOS	A	A	A	A	A	A	A	A	A	A	A	A
Approach Vol, veh/h		605			511			113				36
Approach Delay, s/veh		8.6			9.7			9.2				8.2
Approach LOS		A			A			A				A
Timer - Assigned Phs		2		4		6		8				
Phs Duration (G+Y+Rc), s		14.7		18.2		14.7		18.2				
Change Period (Y+Rc), s		* 4.7		5.4		* 4.7		5.4				
Max Green Setting (Gmax), s		* 23		26.6		* 23		26.6				
Max Q Clear Time (g_c+I1), s		4.6		9.6		2.5		9.6				
Green Ext Time (p_c), s		0.3		3.1		0.1		2.8				
<b>Intersection Summary</b>												
HCM 6th Ctrl Delay			9.1									
HCM 6th LOS			A									
<b>Notes</b>												
* HCM 6th computational engine requires equal clearance times for the phases crossing the barrier.												



Queues  
1: Old Redwood Hwy & Shiloh Road

2028 Opening Year Alter. B Project Conditions

Timing Plan: A.M. PEAK



Lane Group	EBL	EBT	EBR	WBL	WBT	WBR	NBL	NBT	NBR	SBL	SBT	SBR
Lane Group Flow (vph)	169	358	167	28	202	31	129	157	42	44	316	245
v/c Ratio	0.35	0.71	0.32	0.09	0.60	0.08	0.36	0.27	0.08	0.36	0.69	0.48
Control Delay	31.6	40.5	11.2	36.0	45.1	0.4	45.3	27.7	1.6	56.4	41.0	13.7
Queue Delay	0.0	0.0	0.0	0.0	0.0	0.0	0.0	0.0	0.0	0.0	0.0	0.0
Total Delay	31.6	40.5	11.2	36.0	45.1	0.4	45.3	27.7	1.6	56.4	41.0	13.7
Queue Length 50th (ft)	76	181	16	14	108	0	36	70	0	25	164	33
Queue Length 95th (ft)	151	315	62	43	214	0	79	139	7	68	280	98
Internal Link Dist (ft)		1709			528			668			695	
Turn Bay Length (ft)	375		175	200		50	200		98	190		130
Base Capacity (vph)	633	666	649	789	830	763	584	950	845	124	764	743
Starvation Cap Reductn	0	0	0	0	0	0	0	0	0	0	0	0
Spillback Cap Reductn	0	0	0	0	0	0	0	0	0	0	0	0
Storage Cap Reductn	0	0	0	0	0	0	0	0	0	0	0	0
Reduced v/c Ratio	0.27	0.54	0.26	0.04	0.24	0.04	0.22	0.17	0.05	0.35	0.41	0.33

Intersection Summary

Queues  
7: Driveway 1/Gridley Drive & Shiloh Road

2028 Opening Year Alter. B Project Conditions  
Timing Plan: A.M. PEAK

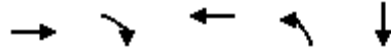

Lane Group	EBT	EBR	WBT	NBL	SBT
Lane Group Flow (vph)	346	52	196	33	26
v/c Ratio	0.49	0.08	0.27	0.09	0.06
Control Delay	8.5	2.2	6.3	9.2	3.8
Queue Delay	0.0	0.0	0.0	0.0	0.0
Total Delay	8.5	2.2	6.3	9.2	3.8
Queue Length 50th (ft)	27	0	14	3	0
Queue Length 95th (ft)	62	8	32	15	5
Internal Link Dist (ft)	528		2066		635
Turn Bay Length (ft)		150			
Base Capacity (vph)	1285	1107	1301	962	1131
Starvation Cap Reductn	0	0	0	0	0
Spillback Cap Reductn	0	0	0	0	0
Storage Cap Reductn	0	0	0	0	0
Reduced v/c Ratio	0.27	0.05	0.15	0.03	0.02
<b>Intersection Summary</b>					

Queues  
1: Old Redwood Hwy & Shiloh Road

2028+P Alternative B\_Mitigations  
Timing Plan: P.M. Peak



Lane Group	EBL	EBT	EBR	WBL	WBT	WBR	NBL	NBT	NBR	SBL	SBT	SBR
Lane Group Flow (vph)	265	370	257	41	367	54	242	373	23	63	265	175
v/c Ratio	0.58	0.77	0.47	0.09	0.78	0.12	0.60	0.76	0.05	0.61	0.70	0.40
Control Delay	43.2	50.7	14.2	33.5	51.0	0.5	54.2	48.1	0.2	78.9	51.7	12.7
Queue Delay	0.0	0.0	0.0	0.0	0.0	0.0	0.0	0.0	0.0	0.0	0.0	0.0
Total Delay	43.2	50.7	14.2	33.5	51.0	0.5	54.2	48.1	0.2	78.9	51.7	12.7
Queue Length 50th (ft)	156	231	35	22	241	0	83	241	0	44	175	16
Queue Length 95th (ft)	307	#478	131	56	396	0	150	390	0	#139	296	80
Internal Link Dist (ft)		1709			528			668			695	
Turn Bay Length (ft)	375		175	200		50	200		98	190		130
Base Capacity (vph)	533	561	610	664	699	647	491	800	708	104	644	634
Starvation Cap Reductn	0	0	0	0	0	0	0	0	0	0	0	0
Spillback Cap Reductn	0	0	0	0	0	0	0	0	0	0	0	0
Storage Cap Reductn	0	0	0	0	0	0	0	0	0	0	0	0
Reduced v/c Ratio	0.50	0.66	0.42	0.06	0.53	0.08	0.49	0.47	0.03	0.61	0.41	0.28

Intersection Summary

# 95th percentile volume exceeds capacity, queue may be longer.  
Queue shown is maximum after two cycles.

Queues  
7: Driveway 1/Gridley Drive & Shiloh Road

2028+P Alternative B\_Mitigations  
Timing Plan: P.M. Peak

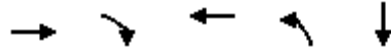

Lane Group	EBT	EBR	WBT	NBL	SBT
Lane Group Flow (vph)	375	81	494	71	24
v/c Ratio	0.48	0.11	0.61	0.21	0.04
Control Delay	8.2	2.1	10.1	11.6	0.1
Queue Delay	0.0	0.0	0.0	0.0	0.0
Total Delay	8.2	2.1	10.1	11.6	0.1
Queue Length 50th (ft)	33	0	47	8	0
Queue Length 95th (ft)	80	11	73	31	0
Internal Link Dist (ft)	528		2066		635
Turn Bay Length (ft)		150			
Base Capacity (vph)	1224	1089	1267	940	1165
Starvation Cap Reductn	0	0	0	0	0
Spillback Cap Reductn	0	0	0	0	0
Storage Cap Reductn	0	0	0	0	0
Reduced v/c Ratio	0.31	0.07	0.39	0.08	0.02
Intersection Summary					

Queues  
1: Old Redwood Hwy & Shiloh Road

2028+P Alternative B\_Mitigations  
Timing Plan: Saturday Midday Peak



Lane Group	EBL	EBT	EBR	WBL	WBT	WBR	NBL	NBT	NBR	SBL	SBT	SBR
Lane Group Flow (vph)	175	509	317	28	567	81	315	300	29	78	251	263
v/c Ratio	0.67	0.55	0.37	0.24	0.82	0.12	0.68	0.61	0.06	0.55	0.72	0.56
Control Delay	60.0	25.8	11.7	59.8	45.4	3.5	56.5	43.9	0.2	68.4	56.3	14.7
Queue Delay	0.0	0.0	0.0	0.0	0.3	0.0	0.0	0.0	0.0	0.0	0.0	0.0
Total Delay	60.0	25.8	11.7	59.8	45.7	3.5	56.5	43.9	0.2	68.4	56.3	14.7
Queue Length 50th (ft)	121	269	67	20	366	0	112	198	0	55	173	29
Queue Length 95th (ft)	214	466	164	53	#673	19	187	314	0	#130	284	115
Internal Link Dist (ft)		1709			528			668			695	
Turn Bay Length (ft)	375		175	200		50	200		98	190		130
Base Capacity (vph)	506	927	852	619	695	656	554	735	678	159	602	648
Starvation Cap Reductn	0	0	0	0	10	0	0	0	0	0	0	0
Spillback Cap Reductn	0	0	0	0	0	0	0	0	0	0	0	0
Storage Cap Reductn	0	0	0	0	0	0	0	0	0	0	0	0
Reduced v/c Ratio	0.35	0.55	0.37	0.05	0.83	0.12	0.57	0.41	0.04	0.49	0.42	0.41

Intersection Summary

# 95th percentile volume exceeds capacity, queue may be longer.  
Queue shown is maximum after two cycles.

Queues  
2: Shiloh Road & Hembree Ln

2028+P Alternative B\_Mitigations  
Timing Plan: Saturday Midday Peak

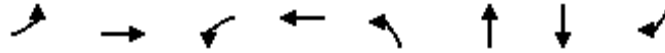

Lane Group	EBL	EBT	WBL	WBT	NBL	NBT	SBT	SBR
Lane Group Flow (vph)	753	910	24	1002	65	26	211	732
v/c Ratio	0.98	0.78	0.19	0.73	0.51	0.19	0.90	1.10
Control Delay	61.4	18.5	42.4	22.5	54.2	28.4	77.2	87.5
Queue Delay	0.0	0.2	0.0	0.0	0.0	0.0	0.0	0.0
Total Delay	61.4	18.7	42.4	22.5	54.2	28.4	77.2	87.5
Queue Length 50th (ft)	186	266	11	209	31	5	102	~326
Queue Length 95th (ft)	#375	#601	39	274	#96	32	#272	#720
Internal Link Dist (ft)		222		1709		136	301	
Turn Bay Length (ft)			100					
Base Capacity (vph)	771	1298	128	1900	128	137	235	666
Starvation Cap Reductn	0	59	0	0	0	0	0	0
Spillback Cap Reductn	0	0	0	0	0	0	0	0
Storage Cap Reductn	0	0	0	0	0	0	0	0
Reduced v/c Ratio	0.98	0.73	0.19	0.53	0.51	0.19	0.90	1.10

Intersection Summary

- ~ Volume exceeds capacity, queue is theoretically infinite.  
Queue shown is maximum after two cycles.
- # 95th percentile volume exceeds capacity, queue may be longer.  
Queue shown is maximum after two cycles.

Queues  
3: US 101 NB Off-Ramp & Shiloh Road

2028+P Alternative B\_Mitigations  
Timing Plan: Saturday Midday Peak

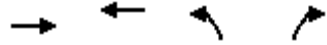

Lane Group	EBT	WBT	NBL	NBR
Lane Group Flow (vph)	624	1105	401	931
v/c Ratio	0.28	0.94	0.88	0.64
Control Delay	7.1	30.0	54.1	9.0
Queue Delay	0.0	2.0	0.0	0.0
Total Delay	7.1	32.0	54.1	9.0
Queue Length 50th (ft)	70	482	222	42
Queue Length 95th (ft)	95	#837	#391	91
Internal Link Dist (ft)	106	291	689	
Turn Bay Length (ft)				265
Base Capacity (vph)	2505	1318	481	1503
Starvation Cap Reductn	0	104	0	0
Spillback Cap Reductn	0	0	0	0
Storage Cap Reductn	0	0	0	0
Reduced v/c Ratio	0.25	0.91	0.83	0.62

Intersection Summary

# 95th percentile volume exceeds capacity, queue may be longer.  
Queue shown is maximum after two cycles.

Queues

4: Shiloh Road & US 101 SB Off-Ramp

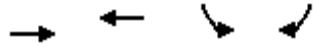

Lane Group	EBT	WBT	SBL	SBR
Lane Group Flow (vph)	363	659	535	256
v/c Ratio	0.42	0.77	0.87	0.36
Control Delay	9.9	17.2	36.3	4.3
Queue Delay	0.0	0.0	0.0	0.0
Total Delay	9.9	17.2	36.3	4.3
Queue Length 50th (ft)	61	138	132	0
Queue Length 95th (ft)	106	233	#233	15
Internal Link Dist (ft)	145	226	406	
Turn Bay Length (ft)				275
Base Capacity (vph)	1863	1863	616	718
Starvation Cap Reductn	0	0	0	0
Spillback Cap Reductn	0	0	0	0
Storage Cap Reductn	0	0	0	0
Reduced v/c Ratio	0.19	0.35	0.87	0.36

Intersection Summary

# 95th percentile volume exceeds capacity, queue may be longer.  
 Queue shown is maximum after two cycles.



Queues  
6: Conde Lane & Shiloh Road

2028+P Alternative B\_Mitigations  
Timing Plan: Saturday Midday Peak

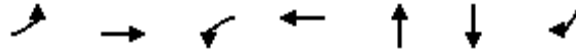

Lane Group	EBL	EBT	WBL	WBT	NBT	SBT	SBR
Lane Group Flow (vph)	34	451	11	784	14	287	41
v/c Ratio	0.10	0.29	0.03	0.58	0.03	0.60	0.07
Control Delay	23.9	9.8	24.5	13.0	0.1	28.8	12.0
Queue Delay	0.0	0.0	0.0	0.0	0.0	0.0	0.0
Total Delay	23.9	9.8	24.5	13.0	0.1	28.8	12.0
Queue Length 50th (ft)	6	26	2	45	0	48	4
Queue Length 95th (ft)	41	113	20	193	0	#247	27
Internal Link Dist (ft)		735		1001	338	442	
Turn Bay Length (ft)	90		127				40
Base Capacity (vph)	369	3083	347	2911	1314	477	1374
Starvation Cap Reductn	0	0	0	0	0	0	0
Spillback Cap Reductn	0	0	0	0	0	0	0
Storage Cap Reductn	0	0	0	0	0	0	0
Reduced v/c Ratio	0.09	0.15	0.03	0.27	0.01	0.60	0.03

Intersection Summary

# 95th percentile volume exceeds capacity, queue may be longer.  
Queue shown is maximum after two cycles.

Queues  
7: Driveway 1/Gridley Drive & Shiloh Road

2028+P Alternative B\_Mitigations  
Timing Plan: Saturday Midday Peak

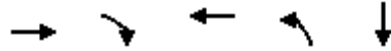

Lane Group	EBT	EBR	WBT	NBL	SBT
Lane Group Flow (vph)	494	111	511	113	36
v/c Ratio	0.65	0.15	0.64	0.28	0.06
Control Delay	12.6	2.2	12.3	14.4	0.1
Queue Delay	0.0	0.0	0.0	0.0	0.0
Total Delay	12.6	2.2	12.3	14.4	0.1
Queue Length 50th (ft)	67	0	69	16	0
Queue Length 95th (ft)	146	16	142	59	0
Internal Link Dist (ft)	528		2066		635
Turn Bay Length (ft)		150			
Base Capacity (vph)	1322	1187	1379	886	1129
Starvation Cap Reductn	0	0	0	0	0
Spillback Cap Reductn	0	0	0	0	0
Storage Cap Reductn	0	0	0	0	0
Reduced v/c Ratio	0.37	0.09	0.37	0.13	0.03
Intersection Summary					

Queues



Lane Group	EBL	EBT	WBT	NBL	NBT	SBL	SBR
Lane Group Flow (vph)	302	394	949	262	519	277	795
v/c Ratio	0.96	0.42	0.76	0.66	0.61	0.94	1.01
Control Delay	81.7	16.0	27.0	35.6	26.8	80.3	50.9
Queue Delay	0.0	0.0	0.0	0.0	0.0	0.0	0.0
Total Delay	81.7	16.0	27.0	35.6	26.8	80.3	50.9
Queue Length 50th (ft)	81	123	203	131	113	74	293
Queue Length 95th (ft)	#180	231	314	215	163	#162	#537
Internal Link Dist (ft)		146	537		636		
Turn Bay Length (ft)	155			270		120	
Base Capacity (vph)	315	932	1244	576	1191	294	790
Starvation Cap Reductn	0	0	0	0	0	0	0
Spillback Cap Reductn	0	0	0	0	0	0	0
Storage Cap Reductn	0	0	0	0	0	0	0
Reduced v/c Ratio	0.96	0.42	0.76	0.45	0.44	0.94	1.01

Intersection Summary

# 95th percentile volume exceeds capacity, queue may be longer.  
 Queue shown is maximum after two cycles.

Queues

























Lane Group	EBT	EBR	WBL	WBT	SBL	SBT
Lane Group Flow (vph)	567	432	507	852	215	201
v/c Ratio	0.40	0.49	1.09	0.33	0.88	0.65
Control Delay	16.2	3.8	95.1	3.9	66.6	27.4
Queue Delay	0.0	0.0	0.0	0.0	0.0	0.0
Total Delay	16.2	3.8	95.1	3.9	66.6	27.4
Queue Length 50th (ft)	89	0	~251	54	96	46
Queue Length 95th (ft)	128	50	#424	74	#151	77
Internal Link Dist (ft)	343			451		751
Turn Bay Length (ft)			250		420	
Base Capacity (vph)	1405	877	467	2568	244	307
Starvation Cap Reductn	0	0	0	0	0	0
Spillback Cap Reductn	0	0	0	0	0	0
Storage Cap Reductn	0	0	0	0	0	0
Reduced v/c Ratio	0.40	0.49	1.09	0.33	0.88	0.65

Intersection Summary

- ~ Volume exceeds capacity, queue is theoretically infinite.  
Queue shown is maximum after two cycles.
- # 95th percentile volume exceeds capacity, queue may be longer.  
Queue shown is maximum after two cycles.

Lanes, Volumes, Timings  
1: Old Redwood Hwy & Shiloh Road

2028 Opening Year Alter. B Project Conditions  
Timing Plan: A.M. PEAK

												
Lane Group	EBL	EBT	EBR	WBL	WBT	WBR	NBL	NBT	NBR	SBL	SBT	SBR
Lane Configurations												
Traffic Volume (vph)	137	290	135	25	180	28	120	146	39	37	269	208
Future Volume (vph)	137	290	135	25	180	28	120	146	39	37	269	208
Ideal Flow (vphpl)	1900	1900	1900	1900	1900	1900	1900	1900	1900	1900	1900	1900
Storage Length (ft)	375		140	0		50	200		98	130		93
Storage Lanes	1		1	0		1	1		1	1		1
Taper Length (ft)	50			25			60			93		
Lane Util. Factor	1.00	1.00	1.00	1.00	1.00	1.00	1.00	1.00	1.00	1.00	1.00	1.00
Ped Bike Factor												0.98
Frt			0.850			0.850			0.850			0.850
Flt Protected	0.950				0.994		0.950			0.950		
Satd. Flow (prot)	1770	1863	1583	0	1852	1583	1770	1863	1583	1770	1863	1583
Flt Permitted	0.950				0.994		0.950			0.950		
Satd. Flow (perm)	1770	1863	1583	0	1852	1583	1770	1863	1583	1770	1863	1549
Right Turn on Red			Yes			Yes			Yes			Yes
Satd. Flow (RTOR)			106			105			77			132
Link Speed (mph)		40			40			45			40	
Link Distance (ft)		1789			608			748			775	
Travel Time (s)		30.5			10.4			11.3			13.2	
Confl. Bikes (#/hr)												1
Peak Hour Factor	0.81	0.81	0.81	0.89	0.89	0.89	0.93	0.93	0.93	0.85	0.85	0.85
Adj. Flow (vph)	169	358	167	28	202	31	129	157	42	44	316	245
Shared Lane Traffic (%)												
Lane Group Flow (vph)	169	358	167	0	230	31	129	157	42	44	316	245
Enter Blocked Intersection	No	No	No	No	No	No	No	No	No	No	No	No
Lane Alignment	Left	Left	Right	Left	Left	Right	Left	Left	Right	Left	Left	Right
Median Width(ft)		12			12			12			12	
Link Offset(ft)		0			0			0			0	
Crosswalk Width(ft)		16			16			16			16	
Two way Left Turn Lane												
Headway Factor	1.00	1.00	1.00	1.00	1.00	1.00	1.00	1.00	1.00	1.00	1.00	1.00
Turning Speed (mph)	15		9	15		9	15		9	15		9
Number of Detectors	1	2	1	1	2	1	1	2	1	1	2	1
Detector Template	Left	Thru	Right	Left	Thru	Right	Left	Thru	Right	Left	Thru	Right
Leading Detector (ft)	20	100	20	20	100	20	20	100	20	20	100	20
Trailing Detector (ft)	0	0	0	0	0	0	0	0	0	0	0	0
Detector 1 Position(ft)	0	0	0	0	0	0	0	0	0	0	0	0
Detector 1 Size(ft)	20	6	20	20	6	20	20	6	20	20	6	20
Detector 1 Type	Cl+Ex	Cl+Ex	Cl+Ex	Cl+Ex	Cl+Ex	Cl+Ex	Cl+Ex	Cl+Ex	Cl+Ex	Cl+Ex	Cl+Ex	Cl+Ex
Detector 1 Channel												
Detector 1 Extend (s)	0.0	0.0	0.0	0.0	0.0	0.0	0.0	0.0	0.0	0.0	0.0	0.0
Detector 1 Queue (s)	0.0	0.0	0.0	0.0	0.0	0.0	0.0	0.0	0.0	0.0	0.0	0.0
Detector 1 Delay (s)	0.0	0.0	0.0	0.0	0.0	0.0	0.0	0.0	0.0	0.0	0.0	0.0
Detector 2 Position(ft)		94			94			94			94	
Detector 2 Size(ft)		6			6			6			6	
Detector 2 Type		Cl+Ex			Cl+Ex			Cl+Ex			Cl+Ex	
Detector 2 Channel												
Detector 2 Extend (s)		0.0			0.0			0.0			0.0	
Turn Type	Split	NA	Perm	Split	NA	Perm	Prot	NA	Perm	Prot	NA	Perm

Lanes, Volumes, Timings  
1: Old Redwood Hwy & Shiloh Road

2028 Opening Year Alter. B Project Conditions

Timing Plan: A.M. PEAK

Lane Group	EBL	EBT	EBR	WBL	WBT	WBR	NBL	NBT	NBR	SBL	SBT	SBR
Protected Phases	2	2		6	6		3	8		7	4	
Permitted Phases			2			6			8			4
Detector Phase	2	2	2	6	6	6	3	8	8	7	4	4
Switch Phase												
Minimum Initial (s)	5.0	5.0	5.0	5.0	5.0	5.0	5.0	5.0	5.0	5.0	5.0	5.0
Minimum Split (s)	34.5	34.5	34.5	42.5	42.5	42.5	8.5	46.5	46.5	8.5	39.5	39.5
Total Split (s)	35.0	35.0	35.0	42.5	42.5	42.5	18.0	48.0	48.0	9.5	39.5	39.5
Total Split (%)	25.9%	25.9%	25.9%	31.5%	31.5%	31.5%	13.3%	35.6%	35.6%	7.0%	29.3%	29.3%
Maximum Green (s)	30.5	30.5	30.5	38.0	38.0	38.0	14.5	43.5	43.5	6.0	35.0	35.0
Yellow Time (s)	3.5	3.5	3.5	3.5	3.5	3.5	3.0	3.5	3.5	3.0	3.5	3.5
All-Red Time (s)	1.0	1.0	1.0	1.0	1.0	1.0	0.5	1.0	1.0	0.5	1.0	1.0
Lost Time Adjust (s)	0.0	0.0	0.0		0.0	0.0	0.0	0.0	0.0	0.0	0.0	0.0
Total Lost Time (s)	4.5	4.5	4.5		4.5	4.5	3.5	4.5	4.5	3.5	4.5	4.5
Lead/Lag	Lead	Lead	Lead	Lag	Lag	Lag	Lead	Lag	Lag	Lead	Lag	Lag
Lead-Lag Optimize?	Yes	Yes	Yes	Yes	Yes	Yes	Yes	Yes	Yes	Yes	Yes	Yes
Vehicle Extension (s)	3.0	3.0	3.0	3.0	3.0	3.0	3.0	3.0	3.0	3.0	3.0	3.0
Recall Mode	None	None	None	None	None	None	None	None	None	None	None	None
Walk Time (s)	7.0	7.0	7.0	7.0	7.0	7.0		7.0	7.0		7.0	7.0
Flash Don't Walk (s)	23.0	23.0	23.0	31.0	31.0	31.0		35.0	35.0		28.0	28.0
Pedestrian Calls (#/hr)	0	0	0	0	0	0		0	0		0	0
Act Effct Green (s)	25.1	25.1	25.1		18.3	18.3	12.3	31.9	31.9	6.2	23.0	23.0
Actuated g/C Ratio	0.26	0.26	0.26		0.19	0.19	0.13	0.33	0.33	0.06	0.24	0.24
v/c Ratio	0.37	0.74	0.34		0.66	0.08	0.57	0.26	0.07	0.39	0.71	0.52
Control Delay (s/veh)	35.1	45.7	15.8		48.6	0.4	55.6	27.8	1.5	61.6	45.2	20.4
Queue Delay	0.0	0.0	0.0		0.0	0.0	0.0	0.0	0.0	0.0	0.0	0.0
Total Delay (s/veh)	35.1	45.7	15.8		48.6	0.4	55.6	27.8	1.5	61.6	45.2	20.4
LOS	D	D	B		D	A	E	C	A	E	D	C
Approach Delay (s/veh)		35.9			42.9			35.4			36.3	
Approach LOS		D			D			D			D	

Intersection Summary

Area Type:	Other
Cycle Length:	135
Actuated Cycle Length:	96.6
Natural Cycle:	135
Control Type:	Actuated-Uncoordinated
Maximum v/c Ratio:	0.74
Intersection Signal Delay (s/veh):	36.9
Intersection LOS:	D
Intersection Capacity Utilization:	61.5%
ICU Level of Service:	B
Analysis Period (min):	15

Splits and Phases: 1: Old Redwood Hwy & Shiloh Road

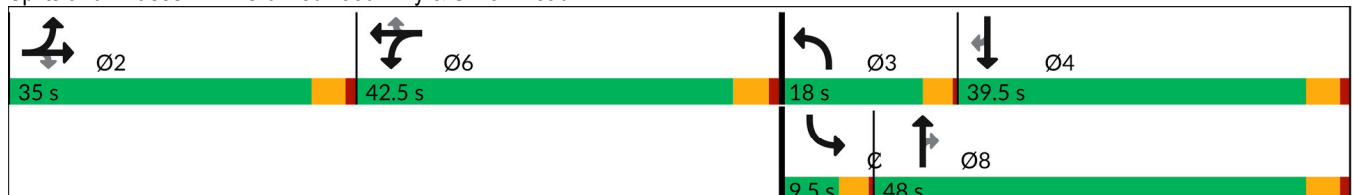

Lanes, Volumes, Timings  
2: Shiloh Road & Hembree Ln

2028 Opening Year Alter. B Project Conditions

Timing Plan: A.M. PEAK

Lane Group	EBL	EBT	EBR	WBL	WBT	WBR	NBL	NBT	NBR	SBL	SBT	SBR
Lane Configurations												
Traffic Volume (vph)	347	511	38	19	466	82	39	7	11	81	9	413
Future Volume (vph)	347	511	38	19	466	82	39	7	11	81	9	413
Ideal Flow (vphpl)	1900	1900	1900	1900	1900	1900	1900	1900	1900	1900	1900	1900
Storage Length (ft)	0		0	100		130	0		0	0		0
Storage Lanes	2		0	1		1	1		0	0		1
Taper Length (ft)	25			50			25			25		
Lane Util. Factor	0.97	1.00	1.00	1.00	0.95	0.95	1.00	1.00	1.00	1.00	1.00	1.00
Frt		0.991			0.977			0.908				0.850
Flt Protected	0.950			0.950			0.950				0.957	
Satd. Flow (prot)	3433	1846	0	1770	3458	0	1770	1691	0	0	1783	1583
Flt Permitted	0.950			0.950			0.950				0.957	
Satd. Flow (perm)	3433	1846	0	1770	3458	0	1770	1691	0	0	1783	1583
Right Turn on Red			Yes			Yes			Yes			Yes
Satd. Flow (RTOR)		6			30			11				305
Link Speed (mph)		40			40			30				35
Link Distance (ft)		302			1789			216				381
Travel Time (s)		5.1			30.5			4.9				7.4
Peak Hour Factor	0.88	0.88	1.00	1.00	0.97	0.97	1.00	1.00	1.00	0.94	1.00	0.94
Adj. Flow (vph)	394	581	38	19	480	85	39	7	11	86	9	439
Shared Lane Traffic (%)												
Lane Group Flow (vph)	394	619	0	19	565	0	39	18	0	0	95	439
Enter Blocked Intersection	No	No	No	No	No	No	No	No	No	No	No	No
Lane Alignment	Left	Left	Right	Left	Left	Right	Left	Left	Right	Left	Left	Right
Median Width(ft)		24			24			12				12
Link Offset(ft)		0			0			0				0
Crosswalk Width(ft)		16			16			16				16
Two way Left Turn Lane												
Headway Factor	1.00	1.00	1.00	1.00	1.00	1.00	1.00	1.00	1.00	1.00	1.00	1.00
Turning Speed (mph)	15		60	60		9	60		60	15		9
Number of Detectors	1	2		1	2		1	2		1	2	1
Detector Template	Left	Thru		Left	Thru		Left	Thru		Left	Thru	Right
Leading Detector (ft)	20	100		20	100		20	100		20	100	20
Trailing Detector (ft)	0	0		0	0		0	0		0	0	0
Detector 1 Position(ft)	0	0		0	0		0	0		0	0	0
Detector 1 Size(ft)	20	6		20	6		20	6		20	6	20
Detector 1 Type	Cl+Ex	Cl+Ex		Cl+Ex	Cl+Ex		Cl+Ex	Cl+Ex		Cl+Ex	Cl+Ex	Cl+Ex
Detector 1 Channel												
Detector 1 Extend (s)	0.0	0.0		0.0	0.0		0.0	0.0		0.0	0.0	0.0
Detector 1 Queue (s)	0.0	0.0		0.0	0.0		0.0	0.0		0.0	0.0	0.0
Detector 1 Delay (s)	0.0	0.0		0.0	0.0		0.0	0.0		0.0	0.0	0.0
Detector 2 Position(ft)		94			94			94				94
Detector 2 Size(ft)		6			6			6				6
Detector 2 Type		Cl+Ex			Cl+Ex			Cl+Ex				Cl+Ex
Detector 2 Channel												
Detector 2 Extend (s)		0.0			0.0			0.0				0.0
Turn Type	Prot	NA		Prot	NA		Split	NA		Split	NA	pt+ov
Protected Phases	5	2		1	6		8	8		4	4	4
Permitted Phases												

Lanes, Volumes, Timings  
2: Shiloh Road & Hembree Ln

2028 Opening Year Alter. B Project Conditions

Timing Plan: A.M. PEAK

Lane Group	EBL	EBT	EBR	WBL	WBT	WBR	NBL	NBT	NBR	SBL	SBT	SBR
Detector Phase	5	2		1	6		8	8		4	4	4 5
Switch Phase												
Minimum Initial (s)	3.0	5.0		5.0	5.0		5.0	5.0		5.0	5.0	
Minimum Split (s)	7.5	9.5		9.5	43.5		9.5	9.5		9.5	9.5	
Total Split (s)	21.0	57.0		9.5	45.5		9.5	9.5		14.0	14.0	
Total Split (%)	23.3%	63.3%		10.6%	50.6%		10.6%	10.6%		15.6%	15.6%	
Maximum Green (s)	17.0	53.0		5.5	41.5		5.5	5.5		10.0	10.0	
Yellow Time (s)	3.0	3.0		3.0	3.0		3.0	3.0		3.0	3.0	
All-Red Time (s)	1.0	1.0		1.0	1.0		1.0	1.0		1.0	1.0	
Lost Time Adjust (s)	0.0	0.0		0.0	0.0		0.0	0.0		0.0	0.0	
Total Lost Time (s)	4.0	4.0		4.0	4.0		4.0	4.0		4.0	4.0	
Lead/Lag	Lead	Lag		Lead	Lag							
Lead-Lag Optimize?	Yes	Yes		Yes	Yes							
Vehicle Extension (s)	3.0	3.0		3.0	3.0		3.0	3.0		3.0	3.0	
Recall Mode	None	None		None	None		None	None		None	None	
Walk Time (s)					7.0							
Flash Don't Walk (s)					32.0							
Pedestrian Calls (#/hr)					1							
Act Effct Green (s)	12.6	33.2		6.2	17.4		6.2	6.2		8.9	23.9	
Actuated g/C Ratio	0.22	0.58		0.11	0.31		0.11	0.11		0.16	0.42	
v/c Ratio	0.52	0.57		0.10	0.53		0.20	0.09		0.34	0.52	
Control Delay (s/veh)	25.4	11.3		34.1	17.7		34.8	24.3		31.5	6.7	
Queue Delay	0.0	0.0		0.0	0.0		0.0	0.0		0.0	0.0	
Total Delay (s/veh)	25.4	11.3		34.1	17.7		34.8	24.3		31.5	6.7	
LOS	C	B		C	B		C	C		C	A	
Approach Delay (s/veh)		16.8			18.2			31.5			11.1	
Approach LOS		B			B			C			B	

Intersection Summary

Area Type:	Other
Cycle Length:	90
Actuated Cycle Length:	57
Natural Cycle:	80
Control Type:	Actuated-Uncoordinated
Maximum v/c Ratio:	0.57
Intersection Signal Delay (s/veh):	16.2
Intersection LOS:	B
Intersection Capacity Utilization:	55.2%
ICU Level of Service:	B
Analysis Period (min):	15

Splits and Phases: 2: Shiloh Road & Hembree Ln





Lanes, Volumes, Timings  
3: US 101 NB Off-Ramp & Shiloh Road

2028 Opening Year Alter. B Project Conditions  
Timing Plan: A.M. PEAK

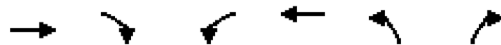

Lane Group	EBT	EBR	WBL	WBT	NBL	NBR
Lane Configurations	↑↑			↑	↘	↗↗
Traffic Volume (vph)	359	0	0	711	492	553
Future Volume (vph)	359	0	0	711	492	553
Ideal Flow (vphpl)	1900	1900	1900	1900	1900	1900
Storage Length (ft)		0	0		0	265
Storage Lanes		0	0		1	2
Taper Length (ft)			25		25	
Lane Util. Factor	0.95	1.00	1.00	1.00	1.00	0.88
Frt						0.850
Flt Protected					0.950	
Satd. Flow (prot)	3539	0	0	1863	1770	2787
Flt Permitted					0.950	
Satd. Flow (perm)	3539	0	0	1863	1770	2787
Right Turn on Red		Yes				Yes
Satd. Flow (RTOR)						629
Link Speed (mph)	40			40	30	
Link Distance (ft)	186			371	769	
Travel Time (s)	3.2			6.3	17.5	
Peak Hour Factor	0.91	0.91	0.90	0.90	0.76	0.76
Adj. Flow (vph)	395	0	0	790	647	728
Shared Lane Traffic (%)						
Lane Group Flow (vph)	395	0	0	790	647	728
Enter Blocked Intersection	No	No	No	No	No	No
Lane Alignment	Left	Right	Left	Left	Left	Right
Median Width(ft)	0			0	12	
Link Offset(ft)	0			0	0	
Crosswalk Width(ft)	16			16	16	
Two way Left Turn Lane						
Headway Factor	1.00	1.00	1.00	1.00	1.00	1.00
Turning Speed (mph)		9	15		15	9
Number of Detectors	2			2	1	1
Detector Template	Thru			Thru	Left	Right
Leading Detector (ft)	100			100	20	20
Trailing Detector (ft)	0			0	0	0
Detector 1 Position(ft)	0			0	0	0
Detector 1 Size(ft)	6			6	20	20
Detector 1 Type	Cl+Ex			Cl+Ex	Cl+Ex	Cl+Ex
Detector 1 Channel						
Detector 1 Extend (s)	0.0			0.0	0.0	0.0
Detector 1 Queue (s)	0.0			0.0	0.0	0.0
Detector 1 Delay (s)	0.0			0.0	0.0	0.0
Detector 2 Position(ft)	94			94		
Detector 2 Size(ft)	6			6		
Detector 2 Type	Cl+Ex			Cl+Ex		
Detector 2 Channel						
Detector 2 Extend (s)	0.0			0.0		
Turn Type	NA			NA	Prot	Perm
Protected Phases	2			6	8	
Permitted Phases						8

Lanes, Volumes, Timings  
 3: US 101 NB Off-Ramp & Shiloh Road

2028 Opening Year Alter. B Project Conditions  
 Timing Plan: A.M. PEAK



Lane Group	EBT	EBR	WBL	WBT	NBL	NBR
Detector Phase	2			6	8	8
Switch Phase						
Minimum Initial (s)	5.0			5.0	5.0	5.0
Minimum Split (s)	9.0			9.0	9.0	9.0
Total Split (s)	37.0			37.0	35.0	35.0
Total Split (%)	51.4%			51.4%	48.6%	48.6%
Maximum Green (s)	33.0			33.0	31.0	31.0
Yellow Time (s)	3.0			3.0	3.0	3.0
All-Red Time (s)	1.0			1.0	1.0	1.0
Lost Time Adjust (s)	0.0			0.0	0.0	0.0
Total Lost Time (s)	4.0			4.0	4.0	4.0
Lead/Lag						
Lead-Lag Optimize?						
Vehicle Extension (s)	3.0			3.0	3.0	3.0
Recall Mode	None			None	None	None
Act Effect Green (s)	31.2			31.2	28.3	28.3
Actuated g/C Ratio	0.46			0.46	0.42	0.42
v/c Ratio	0.24			0.92	0.87	0.48
Control Delay (s/veh)	11.9			36.2	33.6	3.4
Queue Delay	0.0			0.0	0.0	0.0
Total Delay (s/veh)	11.9			36.2	33.6	3.4
LOS	B			D	C	A
Approach Delay (s/veh)	11.9			36.2	17.6	
Approach LOS	B			D	B	

Intersection Summary

Area Type: Other  
 Cycle Length: 72  
 Actuated Cycle Length: 67.6  
 Natural Cycle: 65  
 Control Type: Actuated-Uncoordinated  
 Maximum v/c Ratio: 0.92  
 Intersection Signal Delay (s/veh): 22.5  
 Intersection LOS: C  
 Intersection Capacity Utilization 102.8%  
 ICU Level of Service G  
 Analysis Period (min) 15

Splits and Phases: 3: US 101 NB Off-Ramp & Shiloh Road

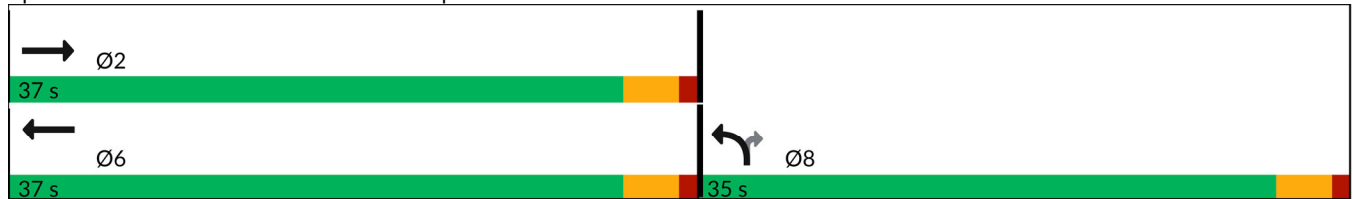

Lanes, Volumes, Timings  
4: Shiloh Road & US 101 SB Off-Ramp

2028 Opening Year Alter. B Project Conditions

Timing Plan: A.M. PEAK

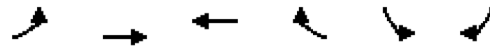

Lane Group	EBL	EBT	WBT	WBR	SBL	SBR
Lane Configurations		↑	↑		↘	↗
Traffic Volume (vph)	0	281	686	0	161	174
Future Volume (vph)	0	281	686	0	161	174
Ideal Flow (vphpl)	1900	1900	1900	1900	1900	1900
Storage Length (ft)	0			0	0	275
Storage Lanes	0			0	1	1
Taper Length (ft)	25				25	
Lane Util. Factor	1.00	1.00	1.00	1.00	1.00	1.00
Frt						0.850
Flt Protected					0.950	
Satd. Flow (prot)	0	1863	1863	0	1770	1583
Flt Permitted					0.950	
Satd. Flow (perm)	0	1863	1863	0	1770	1583
Right Turn on Red				Yes		Yes
Satd. Flow (RTOR)						189
Link Speed (mph)		40	40		30	
Link Distance (ft)		225	306		486	
Travel Time (s)		3.8	5.2		11.0	
Peak Hour Factor	0.93	0.93	0.91	0.91	0.92	0.92
Adj. Flow (vph)	0	302	754	0	175	189
Shared Lane Traffic (%)						
Lane Group Flow (vph)	0	302	754	0	175	189
Enter Blocked Intersection	No	No	No	No	No	No
Lane Alignment	Left	Left	Left	Right	Left	Right
Median Width(ft)		4	0		12	
Link Offset(ft)		0	0		0	
Crosswalk Width(ft)		16	16		16	
Two way Left Turn Lane						
Headway Factor	1.00	1.00	1.00	1.00	1.00	1.00
Turning Speed (mph)	15			9	15	9
Number of Detectors		2	2		1	1
Detector Template		Thru	Thru		Left	Right
Leading Detector (ft)		100	100		20	20
Trailing Detector (ft)		0	0		0	0
Detector 1 Position(ft)		0	0		0	0
Detector 1 Size(ft)		6	6		20	20
Detector 1 Type		Cl+Ex	Cl+Ex		Cl+Ex	Cl+Ex
Detector 1 Channel						
Detector 1 Extend (s)		0.0	0.0		0.0	0.0
Detector 1 Queue (s)		0.0	0.0		0.0	0.0
Detector 1 Delay (s)		0.0	0.0		0.0	0.0
Detector 2 Position(ft)		94	94			
Detector 2 Size(ft)		6	6			
Detector 2 Type		Cl+Ex	Cl+Ex			
Detector 2 Channel						
Detector 2 Extend (s)		0.0	0.0			
Turn Type		NA	NA		Perm	Perm
Protected Phases		2	6			
Permitted Phases					4	4

Lanes, Volumes, Timings  
4: Shiloh Road & US 101 SB Off-Ramp

2028 Opening Year Alter. B Project Conditions  
Timing Plan: A.M. PEAK



Lane Group	EBL	EBT	WBT	WBR	SBL	SBR
Detector Phase		2	6		4	4
Switch Phase						
Minimum Initial (s)		5.0	5.0		5.0	5.0
Minimum Split (s)		9.0	38.0		9.0	9.0
Total Split (s)		69.0	69.0		21.0	21.0
Total Split (%)		76.7%	76.7%		23.3%	23.3%
Maximum Green (s)		65.0	65.0		17.0	17.0
Yellow Time (s)		3.0	3.0		3.0	3.0
All-Red Time (s)		1.0	1.0		1.0	1.0
Lost Time Adjust (s)		0.0	0.0		0.0	0.0
Total Lost Time (s)		4.0	4.0		4.0	4.0
Lead/Lag						
Lead-Lag Optimize?						
Vehicle Extension (s)		3.0	3.0		3.0	3.0
Recall Mode		None	None		None	None
Walk Time (s)			7.0			
Flash Don't Walk (s)			27.0			
Pedestrian Calls (#/hr)			0			
Act Effct Green (s)		24.4	24.4		10.0	10.0
Actuated g/C Ratio		0.57	0.57		0.23	0.23
v/c Ratio		0.29	0.71		0.43	0.37
Control Delay (s/veh)		5.5	11.1		20.1	6.0
Queue Delay		0.0	0.0		0.0	0.0
Total Delay (s/veh)		5.5	11.1		20.1	6.0
LOS		A	B		C	A
Approach Delay (s/veh)		5.5	11.1		12.8	
Approach LOS		A	B		B	

Intersection Summary	
Area Type:	Other
Cycle Length:	90
Actuated Cycle Length:	43
Natural Cycle:	50
Control Type:	Actuated-Uncoordinated
Maximum v/c Ratio:	0.71
Intersection Signal Delay (s/veh):	10.4
Intersection LOS:	B
Intersection Capacity Utilization:	68.9%
ICU Level of Service:	C
Analysis Period (min):	15

Splits and Phases: 4: Shiloh Road & US 101 SB Off-Ramp

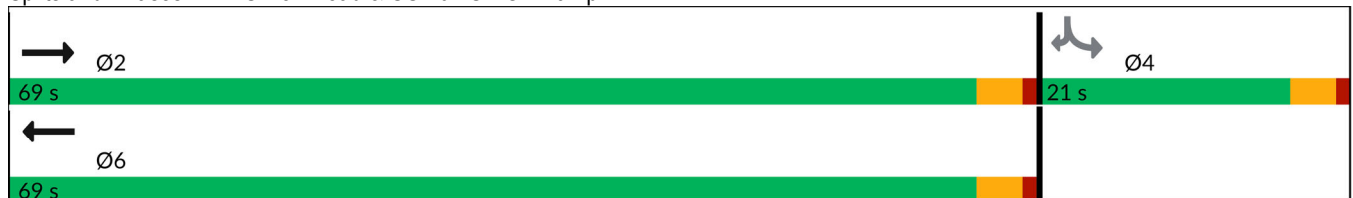

Lanes, Volumes, Timings  
5: Caletti Ave & Shiloh Road

2028 Opening Year Alter. B Project Conditions

Timing Plan: A.M. PEAK

	→	↘	↙	←	↖	↗
Lane Group	EBT	EBR	WBL	WBT	NBL	NBR
Lane Configurations	↑↑		↘	↑	↘	↗
Traffic Volume (vph)	604	25	202	633	8	138
Future Volume (vph)	604	25	202	633	8	138
Ideal Flow (vphpl)	1900	1900	1900	1900	1900	1900
Storage Length (ft)		0	68		0	0
Storage Lanes		0	1		1	1
Taper Length (ft)			50		25	
Lane Util. Factor	0.95	0.95	1.00	1.00	1.00	1.00
Frt	0.994					0.850
Flt Protected			0.950		0.950	
Satd. Flow (prot)	3518	0	1770	1863	1770	1583
Flt Permitted			0.950		0.950	
Satd. Flow (perm)	3518	0	1770	1863	1770	1583
Link Speed (mph)	40			40	30	
Link Distance (ft)	1081			184	459	
Travel Time (s)	18.4			3.1	10.4	
Peak Hour Factor	0.96	0.96	0.87	0.87	0.84	0.84
Adj. Flow (vph)	629	26	232	728	10	164
Shared Lane Traffic (%)						
Lane Group Flow (vph)	655	0	232	728	10	164
Enter Blocked Intersection	No	No	No	No	No	No
Lane Alignment	Left	Right	Left	Left	Left	Right
Median Width(ft)	12			12	12	
Link Offset(ft)	0			0	0	
Crosswalk Width(ft)	16			16	16	
Two way Left Turn Lane						
Headway Factor	1.00	1.00	1.00	1.00	1.00	1.00
Turning Speed (mph)		9	15		15	9
Sign Control	Free			Free	Stop	
<b>Intersection Summary</b>						
Area Type:	Other					
Control Type:	Unsignalized					
Intersection Capacity Utilization	43.3%			ICU Level of Service A		
Analysis Period (min)	15					

Lanes, Volumes, Timings  
6: Conde Lane & Shiloh Road

2028 Opening Year Alter. B Project Conditions

Timing Plan: A.M. PEAK

Lane Group	EBL	EBT	EBR	WBL	WBT	WBR	NBL	NBT	NBR	SBL	SBT	SBR
Lane Configurations												
Traffic Volume (vph)	28	382	6	10	410	232	5	0	14	233	1	40
Future Volume (vph)	28	382	6	10	410	232	5	0	14	233	1	40
Ideal Flow (vphpl)	1900	1900	1900	1900	1900	1900	1900	1900	1900	1900	1900	1900
Storage Length (ft)	90		0	127		0	0		0	0		40
Storage Lanes	1		0	1		0	0		0	0		1
Taper Length (ft)	70			40			25			25		
Lane Util. Factor	1.00	0.95	0.95	1.00	0.95	0.95	1.00	1.00	1.00	1.00	1.00	1.00
Frt		0.998			0.946			0.901				0.850
Flt Protected	0.950			0.950				0.987			0.953	
Satd. Flow (prot)	1770	3532	0	1770	3348	0	0	1657	0	0	1775	1583
Flt Permitted	0.950			0.950				0.987			0.953	
Satd. Flow (perm)	1770	3532	0	1770	3348	0	0	1657	0	0	1775	1583
Right Turn on Red			Yes			Yes			Yes			No
Satd. Flow (RTOR)		2			115			89				
Link Speed (mph)		40			40			30				35
Link Distance (ft)		815			1081			418				522
Travel Time (s)		13.9			18.4			9.5				10.2
Peak Hour Factor	0.95	0.95	0.95	0.85	0.85	0.85	0.57	0.57	0.57	0.86	0.86	0.86
Adj. Flow (vph)	29	402	6	12	482	273	9	0	25	271	1	47
Shared Lane Traffic (%)												
Lane Group Flow (vph)	29	408	0	12	755	0	0	34	0	0	272	47
Enter Blocked Intersection	No	No	No	No	No	No	No	No	No	No	No	No
Lane Alignment	Left	Left	Right	Left	Left	Right	Left	Left	Right	Left	Left	Right
Median Width(ft)		12			12			0				0
Link Offset(ft)		0			0			0				0
Crosswalk Width(ft)		16			16			16				16
Two way Left Turn Lane												
Headway Factor	1.00	1.00	1.00	1.00	1.00	1.00	1.00	1.00	1.00	1.00	1.00	1.00
Turning Speed (mph)	15		9	15		9	15		9	15		9
Number of Detectors	1	2		1	2		1	2		1	1	1
Detector Template	Left	Thru		Left	Thru		Left	Thru		Left	Thru	Right
Leading Detector (ft)	20	100		20	100		20	100		20	30	20
Trailing Detector (ft)	0	0		0	0		0	0		0	0	0
Detector 1 Position(ft)	0	0		0	0		0	0		0	0	0
Detector 1 Size(ft)	20	6		20	6		20	6		20	30	20
Detector 1 Type	Cl+Ex	Cl+Ex		Cl+Ex	Cl+Ex		Cl+Ex	Cl+Ex		Cl+Ex	Cl+Ex	Cl+Ex
Detector 1 Channel												
Detector 1 Extend (s)	0.0	0.0		0.0	0.0		0.0	0.0		0.0	0.0	0.0
Detector 1 Queue (s)	0.0	0.0		0.0	0.0		0.0	0.0		0.0	0.0	0.0
Detector 1 Delay (s)	0.0	0.0		0.0	0.0		0.0	0.0		0.0	0.0	0.0
Detector 2 Position(ft)		94			94			94				
Detector 2 Size(ft)		6			6			6				
Detector 2 Type		Cl+Ex			Cl+Ex			Cl+Ex				
Detector 2 Channel												
Detector 2 Extend (s)		0.0			0.0			0.0				
Turn Type	Prot	NA		Prot	NA		Split	NA		Split	NA	custom
Protected Phases	5	2		1	6		7	7		4	4	
Permitted Phases												6

Lanes, Volumes, Timings  
6: Conde Lane & Shiloh Road

2028 Opening Year Alter. B Project Conditions

Timing Plan: A.M. PEAK

Lane Group	EBL	EBT	EBR	WBL	WBT	WBR	NBL	NBT	NBR	SBL	SBT	SBR
Detector Phase	5	2		1	6		7	7		4	4	6
Switch Phase												
Minimum Initial (s)	8.0	8.0		8.0	8.0		10.0	10.0		11.0	11.0	8.0
Minimum Split (s)	12.0	46.0		12.0	12.0		37.0	37.0		15.0	15.0	12.0
Total Split (s)	13.0	46.0		12.0	45.0		37.0	37.0		15.0	15.0	45.0
Total Split (%)	11.8%	41.8%		10.9%	40.9%		33.6%	33.6%		13.6%	13.6%	40.9%
Maximum Green (s)	9.0	42.0		8.0	41.0		33.0	33.0		11.0	11.0	41.0
Yellow Time (s)	3.0	3.0		3.0	3.0		3.0	3.0		3.0	3.0	3.0
All-Red Time (s)	1.0	1.0		1.0	1.0		1.0	1.0		1.0	1.0	1.0
Lost Time Adjust (s)	0.0	0.0		0.0	0.0		0.0	0.0		0.0	0.0	0.0
Total Lost Time (s)	4.0	4.0		4.0	4.0		4.0	4.0		4.0	4.0	4.0
Lead/Lag	Lead	Lag		Lead	Lag							Lag
Lead-Lag Optimize?	Yes	Yes		Yes	Yes							Yes
Vehicle Extension (s)	3.0	3.0		3.0	3.0		3.0	3.0		3.0	3.0	3.0
Recall Mode	None	None		None	None		None	None		None	None	None
Walk Time (s)		7.0					7.0	7.0				
Flash Don't Walk (s)		35.0					26.0	26.0				
Pedestrian Calls (#/hr)		0					0	0				
Act Effct Green (s)	9.4	19.7		9.3	18.0			11.6			12.8	18.0
Actuated g/C Ratio	0.20	0.42		0.20	0.38			0.25			0.27	0.38
v/c Ratio	0.08	0.28		0.03	0.56			0.07			0.57	0.08
Control Delay (s/veh)	25.6	10.6		25.9	13.1			0.3			30.3	13.2
Queue Delay	0.0	0.0		0.0	0.0			0.0			0.0	0.0
Total Delay (s/veh)	25.6	10.6		25.9	13.1			0.3			30.3	13.2
LOS	C	B		C	B			A			C	B
Approach Delay (s/veh)		11.6			13.3			0.3			27.8	
Approach LOS		B			B			A			C	

Intersection Summary

Area Type:	Other
Cycle Length:	110
Actuated Cycle Length:	47.2
Natural Cycle:	110
Control Type:	Actuated-Uncoordinated
Maximum v/c Ratio:	0.57
Intersection Signal Delay (s/veh):	15.5
Intersection LOS:	B
Intersection Capacity Utilization:	49.6%
ICU Level of Service:	A
Analysis Period (min):	15

Splits and Phases: 6: Conde Lane & Shiloh Road



Lanes, Volumes, Timings  
7: Driveway 1/Gridley Drive & Shiloh Road

2028 Opening Year Alter. B Project Conditions  
Timing Plan: A.M. PEAK

Lane Group	EBL	EBT	EBR	WBL	WBT	WBR	NBL	NBT	NBR	SBL	SBT	SBR
Lane Configurations												
Traffic Volume (vph)	9	306	47	0	167	0	33	0	0	1	0	18
Future Volume (vph)	9	306	47	0	167	0	33	0	0	1	0	18
Ideal Flow (vphp)	1900	1900	1900	1900	1900	1900	1900	1900	1900	1900	1900	1900
Storage Length (ft)	0		150	0		0	0		0	0		0
Storage Lanes	0		1	0		0	1		0	0		0
Taper Length (ft)	25			25			25			25		
Lane Util. Factor	1.00	1.00	1.00	1.00	1.00	1.00	1.00	1.00	1.00	1.00	1.00	1.00
Ped Bike Factor												
Frt			0.850									0.870
Flt Protected		0.999					0.950					0.998
Satd. Flow (prot)	0	1861	1583	0	1863	0	1770	1863	0	0	1617	0
Flt Permitted		0.999					0.950					0.998
Satd. Flow (perm)	0	1861	1583	0	1863	0	1770	1863	0	0	1617	0
Link Speed (mph)		40			40			30			30	
Link Distance (ft)		608			2146			248			715	
Travel Time (s)		10.4			36.6			5.6			16.3	
Confl. Bikes (#/hr)			1									
Peak Hour Factor	0.91	0.91	0.91	0.85	0.85	0.85	1.00	1.00	1.00	0.71	0.71	0.71
Adj. Flow (vph)	10	336	52	0	196	0	33	0	0	1	0	25
Shared Lane Traffic (%)												
Lane Group Flow (vph)	0	346	52	0	196	0	33	0	0	0	26	0
Enter Blocked Intersection	No	No	No	No	No	No	No	No	No	No	No	No
Lane Alignment	Left	Left	Right	Left	Left	Right	Left	Left	Right	Left	Left	Right
Median Width(ft)		0			0			12			12	
Link Offset(ft)		0			0			0			0	
Crosswalk Width(ft)		16			16			16			16	
Two way Left Turn Lane												
Headway Factor	1.00	1.00	1.00	1.00	1.00	1.00	1.00	1.00	1.00	1.00	1.00	1.00
Turning Speed (mph)	15		9	15		9	15		9	15		9
Sign Control		Free			Free			Stop			Stop	

Intersection Summary



















Area Type:	Other
Control Type:	Unsignalized
Intersection Capacity Utilization	38.5%
ICU Level of Service	A
Analysis Period (min)	15



Lanes, Volumes, Timings  
8: Old Redwood Hwy & Driveway 2

2028 Opening Year Alter. B Project Conditions

Timing Plan: A.M. PEAK

												
Lane Group	EBL	EBT	EBR	WBL	WBT	WBR	NBL	NBT	NBR	SBL	SBT	SBR
Lane Configurations												
Traffic Volume (vph)	1	0	0	19	0	31	0	247	28	45	360	0
Future Volume (vph)	1	0	0	19	0	31	0	247	28	45	360	0
Ideal Flow (vphp)	1900	1900	1900	1900	1900	1900	1900	1900	1900	1900	1900	1900
Storage Length (ft)	0		0	0		0	0		100	50		0
Storage Lanes	0		0	1		0	0		1	1		0
Taper Length (ft)	25			25			25			25		
Lane Util. Factor	1.00	1.00	1.00	1.00	1.00	1.00	1.00	1.00	1.00	1.00	1.00	1.00
Ped Bike Factor												
Frt					0.850				0.850			
Flt Protected		0.950		0.950						0.950		
Satd. Flow (prot)	0	1770	0	1770	1583	0	0	1863	1583	1770	1863	0
Flt Permitted		0.950		0.950						0.950		
Satd. Flow (perm)	0	1770	0	1770	1583	0	0	1863	1583	1770	1863	0
Link Speed (mph)		30			30			45			45	
Link Distance (ft)		98			385			520			748	
Travel Time (s)		2.2			8.8			7.9			11.3	
Confl. Peds. (#/hr)									1	1		
Confl. Bikes (#/hr)									1			2
Peak Hour Factor	0.25	0.25	0.25	1.00	1.00	1.00	0.99	0.99	0.99	0.90	0.90	0.90
Adj. Flow (vph)	4	0	0	19	0	31	0	249	28	50	400	0
Shared Lane Traffic (%)												
Lane Group Flow (vph)	0	4	0	19	31	0	0	249	28	50	400	0
Enter Blocked Intersection	No	No	No	No	No	No	No	No	No	No	No	No
Lane Alignment	Left	Left	Right	Left	Left	Right	Left	Left	Right	Left	Left	Right
Median Width(ft)		12			12			12			12	
Link Offset(ft)		0			0			0			0	
Crosswalk Width(ft)		16			16			16			16	
Two way Left Turn Lane												
Headway Factor	1.00	1.00	1.00	1.00	1.00	1.00	1.00	1.00	1.00	1.00	1.00	1.00
Turning Speed (mph)	15		9	15		9	15		9	15		9
Sign Control		Stop			Stop			Free			Free	

Intersection Summary

Area Type:	Other
Control Type:	Unsignalized
Intersection Capacity Utilization	45.3%
Analysis Period (min)	15
	ICU Level of Service A

Lanes, Volumes, Timings  
 9: Driveway 3 & Shiloh Road

2028 Opening Year Alter. B Project Conditions  
 Timing Plan: A.M. PEAK

	→	↘	↙	←	↖	↗
Lane Group	EBT	EBR	WBL	WBT	NBL	NBR
Lane Configurations	↑	↗		↖	↘	↗
Traffic Volume (vph)	159	145	14	59	101	10
Future Volume (vph)	159	145	14	59	101	10
Ideal Flow (vphpl)	1900	1900	1900	1900	1900	1900
Storage Length (ft)		200	0		0	0
Storage Lanes		1	0		1	1
Taper Length (ft)			25		25	
Lane Util. Factor	1.00	1.00	1.00	1.00	1.00	1.00
Frt		0.850				0.850
Flt Protected				0.991	0.950	
Satd. Flow (prot)	1863	1583	0	1846	1770	1583
Flt Permitted				0.991	0.950	
Satd. Flow (perm)	1863	1583	0	1846	1770	1583
Link Speed (mph)	40			40	30	
Link Distance (ft)	2146			134	402	
Travel Time (s)	36.6			2.3	9.1	
Peak Hour Factor	0.85	0.85	0.81	0.81	1.00	1.00
Adj. Flow (vph)	187	171	17	73	101	10
Shared Lane Traffic (%)						
Lane Group Flow (vph)	187	171	0	90	101	10
Enter Blocked Intersection	No	No	No	No	No	No
Lane Alignment	Left	Right	Left	Left	Left	Right
Median Width(ft)	0			0	12	
Link Offset(ft)	0			0	0	
Crosswalk Width(ft)	16			16	16	
Two way Left Turn Lane						
Headway Factor	1.00	1.00	1.00	1.00	1.00	1.00
Turning Speed (mph)		9	15		15	9
Sign Control	Free			Free	Stop	

Intersection Summary	
Area Type:	Other
Control Type:	Unsignalized
Intersection Capacity Utilization	27.4%
	ICU Level of Service A
Analysis Period (min)	15

Lanes, Volumes, Timings

2028 Opening Year Alter. B Project Conditions

10: US 101 NB Off Ramp/Lakewood Drive & Old Redwood Highway

Timing Plan: A.M. PEAK



Lane Group	EBL	EBT	EBR	WBL	WBT	WBR	NBL	NBT	NBR	SBL	SBT	SBR
Lane Configurations												
Traffic Volume (vph)	173	198	0	0	520	170	258	252	90	134	0	608
Future Volume (vph)	173	198	0	0	520	170	258	252	90	134	0	608
Ideal Flow (vphpl)	1900	1900	1900	1900	1900	1900	1900	1900	1900	1900	1900	1900
Storage Length (ft)	155		0	0		0	270		150	120		0
Storage Lanes	1		0	0		0	1		1	1		1
Taper Length (ft)	50			25			165			75		
Lane Util. Factor	0.97	1.00	1.00	1.00	0.95	0.95	0.91	0.91	0.95	0.97	1.00	1.00
Ped Bike Factor	1.00				1.00			1.00		1.00		
Flt					0.963			0.966				0.850
Flt Protected	0.950						0.950	0.993		0.950		
Satd. Flow (prot)	3433	1863	0	0	3397	0	1610	3242	0	3433	0	1583
Flt Permitted	0.950						0.950	0.993		0.950		
Satd. Flow (perm)	3431	1863	0	0	3397	0	1610	3242	0	3427	0	1583
Right Turn on Red			Yes			Yes			Yes			Yes
Satd. Flow (RTOR)					50			41				277
Link Speed (mph)		35			35			30				30
Link Distance (ft)		226			617			716				478
Travel Time (s)		4.4			12.0			16.3				10.9
Confl. Peds. (#/hr)	1		1	1		1			2	2		
Confl. Bikes (#/hr)			1			1						
Peak Hour Factor	0.85	0.85	0.85	0.83	0.83	0.83	0.90	0.90	0.90	0.89	0.89	0.89
Adj. Flow (vph)	204	233	0	0	627	205	287	280	100	151	0	683
Shared Lane Traffic (%)							23%					
Lane Group Flow (vph)	204	233	0	0	832	0	221	446	0	151	0	683
Enter Blocked Intersection	No	No	No	No	No	No	No	No	No	No	No	No
Lane Alignment	Left	Left	Right	Left	Left	Right	Left	Left	Right	Left	Left	Right
Median Width(ft)		24			24			24				24
Link Offset(ft)		0			0			0				0
Crosswalk Width(ft)		16			16			16				16
Two way Left Turn Lane												
Headway Factor	1.00	1.00	1.00	1.00	1.00	1.00	1.00	1.00	1.00	1.00	1.00	1.00
Turning Speed (mph)	15		9	15		9	15		9	15		9
Number of Detectors	1	2			2		1	2		1		1
Detector Template	Left	Thru			Thru		Left	Thru		Left		Right
Leading Detector (ft)	20	100			100		20	100		20		20
Trailing Detector (ft)	0	0			0		0	0		0		0
Detector 1 Position(ft)	0	0			0		0	0		0		0
Detector 1 Size(ft)	20	6			6		20	6		20		20
Detector 1 Type	Cl+Ex	Cl+Ex			Cl+Ex		Cl+Ex	Cl+Ex		Cl+Ex		Cl+Ex
Detector 1 Channel												
Detector 1 Extend (s)	0.0	0.0			0.0		0.0	0.0		0.0		0.0
Detector 1 Queue (s)	0.0	0.0			0.0		0.0	0.0		0.0		0.0
Detector 1 Delay (s)	0.0	0.0			0.0		0.0	0.0		0.0		0.0
Detector 2 Position(ft)		94			94			94				
Detector 2 Size(ft)		6			6			6				
Detector 2 Type		Cl+Ex			Cl+Ex			Cl+Ex				
Detector 2 Channel												
Detector 2 Extend (s)		0.0			0.0			0.0				

Lanes, Volumes, Timings

2028 Opening Year Alter. B Project Conditions

10: US 101 NB Off Ramp/Lakewood Drive & Old Redwood Highway

Timing Plan: A.M. PEAK



Lane Group	EBL	EBT	EBR	WBL	WBT	WBR	NBL	NBT	NBR	SBL	SBT	SBR
Turn Type	Prot	NA			NA		Split	NA		Prot		pm+ov
Protected Phases	5	2			6		8	8		7		5
Permitted Phases												5 8
Detector Phase	5	2			6		8	8		7		5
Switch Phase												
Minimum Initial (s)	7.0	10.0			10.0		10.0	10.0		7.0		7.0
Minimum Split (s)	11.0	32.1			32.1		33.7	33.7		11.0		11.0
Total Split (s)	13.0	45.3			32.3		33.7	33.7		11.0		13.0
Total Split (%)	14.4%	50.3%			35.9%		37.4%	37.4%		12.2%		14.4%
Maximum Green (s)	9.0	40.2			27.2		29.0	29.0		7.0		9.0
Yellow Time (s)	3.0	4.1			4.1		3.7	3.7		3.0		3.0
All-Red Time (s)	1.0	1.0			1.0		1.0	1.0		1.0		1.0
Lost Time Adjust (s)	0.0	0.0			0.0		0.0	0.0		0.0		0.0
Total Lost Time (s)	4.0	5.1			5.1		4.7	4.7		4.0		4.0
Lead/Lag	Lead				Lag		Lag	Lag		Lead		Lead
Lead-Lag Optimize?	Yes				Yes		Yes	Yes		Yes		Yes
Vehicle Extension (s)	3.0	3.0			3.0		3.0	3.0		3.0		3.0
Recall Mode	None	Max			Max		None	None		None		None
Walk Time (s)		7.0			7.0		7.0	7.0				
Flash Don't Walk (s)		20.0			17.0		22.0	22.0				
Pedestrian Calls (#/hr)		0			0		0	0				
Act Effct Green (s)	8.6	40.4			27.7		17.7	17.7		7.0		31.1
Actuated g/C Ratio	0.11	0.51			0.35		0.22	0.22		0.09		0.39
v/c Ratio	0.54	0.24			0.68		0.61	0.59		0.50		0.86
Control Delay (s/veh)	40.3	12.8			24.9		34.9	27.7		41.8		25.1
Queue Delay	0.0	0.0			0.0		0.0	0.0		0.0		0.0
Total Delay (s/veh)	40.3	12.8			24.9		34.9	27.7		41.8		25.1
LOS	D	B			C		C	C		D		C
Approach Delay (s/veh)		25.7			24.9			30.1				28.1
Approach LOS		C			C			C				C

Intersection Summary

Area Type: Other  
 Cycle Length: 90  
 Actuated Cycle Length: 79  
 Natural Cycle: 90  
 Control Type: Actuated-Uncoordinated  
 Maximum v/c Ratio: 0.86  
 Intersection Signal Delay (s/veh): 27.2  
 Intersection LOS: C  
 Intersection Capacity Utilization 81.6%  
 ICU Level of Service D  
 Analysis Period (min) 15

Splits and Phases: 10: US 101 NB Off Ramp/Lakewood Drive & Old Redwood Highway

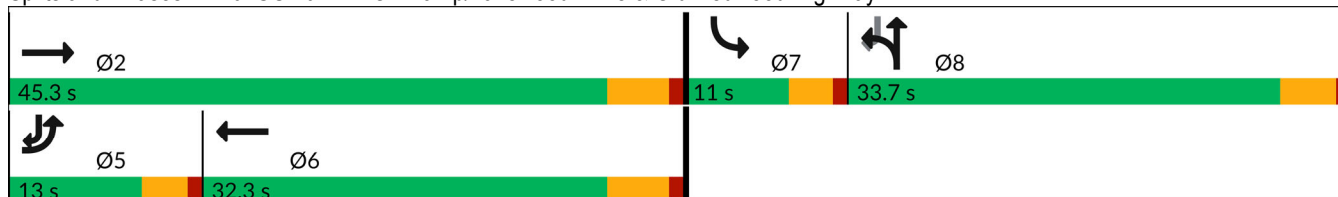

Lanes, Volumes, Timings  
 11: Old Redwood Highway & US 101 NB On Ramp

2028 Opening Year Alter. B Project Conditions  
 Timing Plan: A.M. PEAK

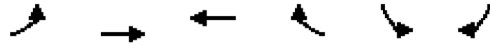

Lane Group	EBL	EBT	WBT	WBR	SBL	SBR
Lane Configurations						
Traffic Volume (vph)	98	368	1152	216	0	0
Future Volume (vph)	98	368	1152	216	0	0
Ideal Flow (vphp)	1900	1900	1900	1900	1900	1900
Storage Length (ft)	245			0	0	0
Storage Lanes	1			0	0	0
Taper Length (ft)	50				25	
Lane Util. Factor	1.00	0.95	0.95	0.95	1.00	1.00
Ped Bike Factor						
Frt			0.976			
Flt Protected	0.950					
Satd. Flow (prot)	1770	3539	3454	0	0	0
Flt Permitted	0.950					
Satd. Flow (perm)	1770	3539	3454	0	0	0
Link Speed (mph)		35	35		30	
Link Distance (ft)		531	226		299	
Travel Time (s)		10.3	4.4		6.8	
Confl. Peds. (#/hr)	9					
Confl. Bikes (#/hr)				1		
Peak Hour Factor	0.81	0.81	0.89	0.89	0.25	0.25
Adj. Flow (vph)	121	454	1294	243	0	0
Shared Lane Traffic (%)						
Lane Group Flow (vph)	121	454	1537	0	0	0
Enter Blocked Intersection	No	No	No	No	No	No
Lane Alignment	Left	Left	Left	Right	Left	Right
Median Width(ft)		12	12		0	
Link Offset(ft)		0	0		0	
Crosswalk Width(ft)		16	16		16	
Two way Left Turn Lane						
Headway Factor	1.00	1.00	1.00	1.00	1.00	1.00
Turning Speed (mph)	15			9	15	9
Sign Control		Free	Free		Free	

Intersection Summary

Area Type:	Other
Control Type:	Unsignalized
Intersection Capacity Utilization	74.7%
Analysis Period (min)	15
	ICU Level of Service D

Lanes, Volumes, Timings

2028 Opening Year Alter. B Project Conditions

12: US 101 SB On Ramp/US 101 SB Off Ramp & Old Redwood Highway

Timing Plan: A.M. PEAK



Lane Group	EBL	EBT	EBR	WBL	WBT	WBR	NBL	NBT	NBR	SBL	SBT	SBR
Lane Configurations		↑↑	↗	↘	↑↑					↘	↕	
Traffic Volume (vph)	0	339	337	584	574	0	0	0	0	133	1	74
Future Volume (vph)	0	339	337	584	574	0	0	0	0	133	1	74
Ideal Flow (vphpl)	1900	1900	1900	1900	1900	1900	1900	1900	1900	1900	1900	1900
Storage Length (ft)	0		0	250		0	0		0	420		0
Storage Lanes	0		1	0		0	0		0	1		0
Taper Length (ft)	25			165			25			75		
Lane Util. Factor	1.00	0.95	1.00	1.00	0.95	1.00	1.00	1.00	1.00	0.95	0.95	1.00
Ped Bike Factor			0.98	1.00								
Frt			0.850								0.889	
Flt Protected				0.950						0.950	0.988	
Satd. Flow (prot)	0	3539	1583	1770	3539	0	0	0	0	1681	1554	0
Flt Permitted				0.950						0.950	0.988	
Satd. Flow (perm)	0	3539	1558	1767	3539	0	0	0	0	1681	1554	0
Right Turn on Red			Yes			Yes			Yes			Yes
Satd. Flow (RTOR)			350								91	
Link Speed (mph)		35			35			30			30	
Link Distance (ft)		423			531			621			831	
Travel Time (s)		8.2			10.3			14.1			18.9	
Confl. Peds. (#/hr)	10		3	3		10						
Confl. Bikes (#/hr)			2									
Peak Hour Factor	0.92	0.92	0.92	0.89	0.89	0.89	0.25	0.25	0.25	0.81	0.81	0.81
Adj. Flow (vph)	0	368	366	656	645	0	0	0	0	164	1	91
Shared Lane Traffic (%)										19%		
Lane Group Flow (vph)	0	368	366	656	645	0	0	0	0	133	123	0
Enter Blocked Intersection	No	No	No	No	No	No	No	No	No	No	No	No
Lane Alignment	Left	Left	Right	Left	Left	Right	Left	Left	Right	Left	Left	Right
Median Width(ft)		24			24			12			12	
Link Offset(ft)		0			0			0			0	
Crosswalk Width(ft)		16			16			16			16	
Two way Left Turn Lane												
Headway Factor	1.00	1.00	1.00	1.00	1.00	1.00	1.00	1.00	1.00	1.00	1.00	1.00
Turning Speed (mph)	15		9	15		9	15		9	15		9
Number of Detectors		2	1	1	2					1	2	
Detector Template		Thru	Right	Left	Thru					Left	Thru	
Leading Detector (ft)		100	20	20	100					20	100	
Trailing Detector (ft)		0	0	0	0					0	0	
Detector 1 Position(ft)		0	0	0	0					0	0	
Detector 1 Size(ft)		6	20	20	6					20	6	
Detector 1 Type		Cl+Ex	Cl+Ex	Cl+Ex	Cl+Ex					Cl+Ex	Cl+Ex	
Detector 1 Channel												
Detector 1 Extend (s)		0.0	0.0	0.0	0.0					0.0	0.0	
Detector 1 Queue (s)		0.0	0.0	0.0	0.0					0.0	0.0	
Detector 1 Delay (s)		0.0	0.0	0.0	0.0					0.0	0.0	
Detector 2 Position(ft)		94			94							94
Detector 2 Size(ft)		6			6							6
Detector 2 Type		Cl+Ex			Cl+Ex							Cl+Ex
Detector 2 Channel												
Detector 2 Extend (s)		0.0			0.0							0.0

Lanes, Volumes, Timings

2028 Opening Year Alter. B Project Conditions

12: US 101 SB On Ramp/US 101 SB Off Ramp & Old Redwood Highway

Timing Plan: A.M. PEAK



Lane Group	EBL	EBT	EBR	WBL	WBT	WBR	NBL	NBT	NBR	SBL	SBT	SBR
Turn Type		NA	Perm	Prot	NA					Perm	NA	
Protected Phases		6		5	2						8	
Permitted Phases			6							8		
Detector Phase		6	6	5	2					8	8	
Switch Phase												
Minimum Initial (s)		10.0	10.0	7.0	10.0					10.0	10.0	
Minimum Split (s)		32.1	32.1	11.0	38.1					14.7	14.7	
Total Split (s)		32.3	32.3	33.0	65.3					14.7	14.7	
Total Split (%)		40.4%	40.4%	41.3%	81.6%					18.4%	18.4%	
Maximum Green (s)		27.2	27.2	29.0	60.2					10.0	10.0	
Yellow Time (s)		4.1	4.1	3.0	4.1					3.7	3.7	
All-Red Time (s)		1.0	1.0	1.0	1.0					1.0	1.0	
Lost Time Adjust (s)		0.0	0.0	0.0	0.0					0.0	0.0	
Total Lost Time (s)		5.1	5.1	4.0	5.1					4.7	4.7	
Lead/Lag		Lag	Lag	Lead								
Lead-Lag Optimize?		Yes	Yes	Yes								
Vehicle Extension (s)		3.0	3.0	3.0	3.0					3.0	3.0	
Recall Mode		Max	Max	None	Max					None	None	
Walk Time (s)		7.0	7.0		7.0							
Flash Don't Walk (s)		20.0	20.0		25.0							
Pedestrian Calls (#/hr)		0	0		0							
Act Effct Green (s)		27.2	27.2	29.0	60.2					10.0	10.0	
Actuated g/C Ratio		0.34	0.34	0.36	0.75					0.13	0.13	
v/c Ratio		0.31	0.48	1.02	0.24					0.63	0.45	
Control Delay (s/veh)		20.3	5.2	69.4	3.2					48.4	17.6	
Queue Delay		0.0	0.0	0.0	0.0					0.0	0.0	
Total Delay (s/veh)		20.3	5.2	69.4	3.2					48.4	17.6	
LOS		C	A	E	A					D	B	
Approach Delay (s/veh)		12.8			36.6						33.6	
Approach LOS		B			D						C	

Intersection Summary

Area Type: Other

Cycle Length: 80

Actuated Cycle Length: 80

Natural Cycle: 80

Control Type: Actuated-Uncoordinated

Maximum v/c Ratio: 1.02

Intersection Signal Delay (s/veh): 28.6

Intersection LOS: C

Intersection Capacity Utilization 74.7%

ICU Level of Service D

Analysis Period (min) 15



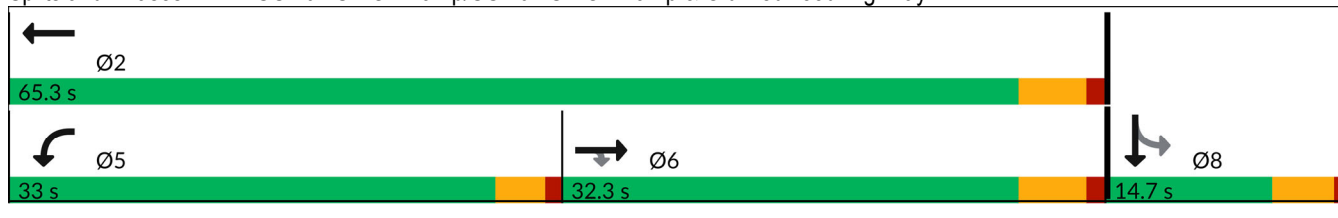



















Splits and Phases: 12: US 101 SB On Ramp/US 101 SB Off Ramp & Old Redwood Highway



Lanes, Volumes, Timings  
1: Old Redwood Hwy & Shiloh Road

2028 Opening Year Alter. B Project Conditions

Timing Plan: P.M. Peak

												
Lane Group	EBL	EBT	EBR	WBL	WBT	WBR	NBL	NBT	NBR	SBL	SBT	SBR
Lane Configurations												
Traffic Volume (vph)	257	359	249	37	334	49	225	347	21	59	246	163
Future Volume (vph)	257	359	249	37	334	49	225	347	21	59	246	163
Ideal Flow (vphpl)	1900	1900	1900	1900	1900	1900	1900	1900	1900	1900	1900	1900
Storage Length (ft)	375		140	0		50	200		98	130		93
Storage Lanes	1		1	0		1	1		1	1		1
Taper Length (ft)	50			25			60			93		
Lane Util. Factor	1.00	1.00	1.00	1.00	1.00	1.00	1.00	1.00	1.00	1.00	1.00	1.00
Ped Bike Factor	1.00					0.98	1.00		0.98			0.97
Frt			0.850			0.850			0.850			0.850
Flt Protected	0.950				0.995		0.950			0.950		
Satd. Flow (prot)	1770	1863	1583	0	1853	1583	1770	1863	1583	1770	1863	1583
Flt Permitted	0.950				0.995		0.950			0.950		
Satd. Flow (perm)	1768	1863	1583	0	1853	1549	1767	1863	1546	1770	1863	1542
Right Turn on Red			Yes			Yes			Yes			Yes
Satd. Flow (RTOR)			158			105			77			112
Link Speed (mph)		40			40			45			40	
Link Distance (ft)		1789			608			748			775	
Travel Time (s)		30.5			10.4			11.3			13.2	
Confl. Peds. (#/hr)	1						1	1				1
Confl. Bikes (#/hr)									3			3
Peak Hour Factor	0.97	0.97	0.97	0.91	0.91	0.91	0.93	0.93	0.93	0.93	0.93	0.93
Adj. Flow (vph)	265	370	257	41	367	54	242	373	23	63	265	175
Shared Lane Traffic (%)												
Lane Group Flow (vph)	265	370	257	0	408	54	242	373	23	63	265	175
Enter Blocked Intersection	No	No	No	No	No	No	No	No	No	No	No	No
Lane Alignment	Left	Left	Right	Left	Left	Right	Left	Left	Right	Left	Left	Right
Median Width(ft)		12			12			12			12	
Link Offset(ft)		0			0			0			0	
Crosswalk Width(ft)		16			16			16			16	
Two way Left Turn Lane												
Headway Factor	1.00	1.00	1.00	1.00	1.00	1.00	1.00	1.00	1.00	1.00	1.00	1.00
Turning Speed (mph)	15		9	15		9	15		9	15		9
Number of Detectors	1	2	1	1	2	1	1	2	1	1	2	1
Detector Template	Left	Thru	Right	Left	Thru	Right	Left	Thru	Right	Left	Thru	Right
Leading Detector (ft)	20	100	20	20	100	20	20	100	20	20	100	20
Trailing Detector (ft)	0	0	0	0	0	0	0	0	0	0	0	0
Detector 1 Position(ft)	0	0	0	0	0	0	0	0	0	0	0	0
Detector 1 Size(ft)	20	6	20	20	6	20	20	6	20	20	6	20
Detector 1 Type	Cl+Ex	Cl+Ex	Cl+Ex	Cl+Ex	Cl+Ex	Cl+Ex	Cl+Ex	Cl+Ex	Cl+Ex	Cl+Ex	Cl+Ex	Cl+Ex
Detector 1 Channel												
Detector 1 Extend (s)	0.0	0.0	0.0	0.0	0.0	0.0	0.0	0.0	0.0	0.0	0.0	0.0
Detector 1 Queue (s)	0.0	0.0	0.0	0.0	0.0	0.0	0.0	0.0	0.0	0.0	0.0	0.0
Detector 1 Delay (s)	0.0	0.0	0.0	0.0	0.0	0.0	0.0	0.0	0.0	0.0	0.0	0.0
Detector 2 Position(ft)		94			94			94			94	
Detector 2 Size(ft)		6			6			6			6	
Detector 2 Type		Cl+Ex			Cl+Ex			Cl+Ex			Cl+Ex	
Detector 2 Channel												
Detector 2 Extend (s)		0.0			0.0			0.0			0.0	



Lanes, Volumes, Timings  
1: Old Redwood Hwy & Shiloh Road

2028 Opening Year Alter. B Project Conditions

Timing Plan: P.M. Peak

Lane Group	EBL	EBT	EBR	WBL	WBT	WBR	NBL	NBT	NBR	SBL	SBT	SBR
Turn Type	Split	NA	Perm	Split	NA	Perm	Prot	NA	Perm	Prot	NA	Perm
Protected Phases	2	2		6	6		3	8		7	4	
Permitted Phases			2			6			8			4
Detector Phase	2	2	2	6	6	6	3	8	8	7	4	4
Switch Phase												
Minimum Initial (s)	5.0	5.0	5.0	5.0	5.0	5.0	5.0	5.0	5.0	5.0	5.0	5.0
Minimum Split (s)	34.5	34.5	34.5	42.5	42.5	42.5	8.5	46.5	46.5	8.5	39.5	39.5
Total Split (s)	35.0	35.0	35.0	42.5	42.5	42.5	18.0	48.0	48.0	9.5	39.5	39.5
Total Split (%)	25.9%	25.9%	25.9%	31.5%	31.5%	31.5%	13.3%	35.6%	35.6%	7.0%	29.3%	29.3%
Maximum Green (s)	30.5	30.5	30.5	38.0	38.0	38.0	14.5	43.5	43.5	6.0	35.0	35.0
Yellow Time (s)	3.5	3.5	3.5	3.5	3.5	3.5	3.0	3.5	3.5	3.0	3.5	3.5
All-Red Time (s)	1.0	1.0	1.0	1.0	1.0	1.0	0.5	1.0	1.0	0.5	1.0	1.0
Lost Time Adjust (s)	0.0	0.0	0.0		0.0	0.0	0.0	0.0	0.0	0.0	0.0	0.0
Total Lost Time (s)	4.5	4.5	4.5		4.5	4.5	3.5	4.5	4.5	3.5	4.5	4.5
Lead/Lag	Lead	Lead	Lead	Lag	Lag	Lag	Lead	Lag	Lag	Lead	Lag	Lag
Lead-Lag Optimize?	Yes	Yes	Yes	Yes	Yes	Yes	Yes	Yes	Yes	Yes	Yes	Yes
Vehicle Extension (s)	3.0	3.0	3.0	3.0	3.0	3.0	3.0	3.0	3.0	3.0	3.0	3.0
Recall Mode	None	None	None	None	None	None	None	None	None	None	None	None
Walk Time (s)	7.0	7.0	7.0	7.0	7.0	7.0		7.0	7.0		7.0	7.0
Flash Don't Walk (s)	23.0	23.0	23.0	31.0	31.0	31.0		35.0	35.0		28.0	28.0
Pedestrian Calls (#/hr)	0	0	0	0	0	0		0	0		0	0
Act Effct Green (s)	27.6	27.6	27.6		29.5	29.5	14.9	30.5	30.5	6.2	21.7	21.7
Actuated g/C Ratio	0.25	0.25	0.25		0.27	0.27	0.13	0.27	0.27	0.06	0.20	0.20
v/c Ratio	0.61	0.80	0.50		0.83	0.11	1.02	0.73	0.05	0.64	0.73	0.45
Control Delay (s/veh)	46.1	55.5	19.4		54.9	0.4	114.7	47.3	0.2	85.8	55.6	20.0
Queue Delay	0.0	0.0	0.0		0.0	0.0	0.0	0.0	0.0	0.0	0.0	0.0
Total Delay (s/veh)	46.1	55.5	19.4		54.9	0.4	114.7	47.3	0.2	85.8	55.6	20.0
LOS	D	E	B		D	A	F	D	A	F	E	B
Approach Delay (s/veh)		42.3			48.6			71.2			47.0	
Approach LOS		D			D			E			D	

Intersection Summary

Area Type: Other  
 Cycle Length: 135  
 Actuated Cycle Length: 111.2  
 Natural Cycle: 135  
 Control Type: Actuated-Uncoordinated  
 Maximum v/c Ratio: 1.02  
 Intersection Signal Delay (s/veh): 51.8  
 Intersection LOS: D  
 Intersection Capacity Utilization 79.4%  
 ICU Level of Service D  
 Analysis Period (min) 15



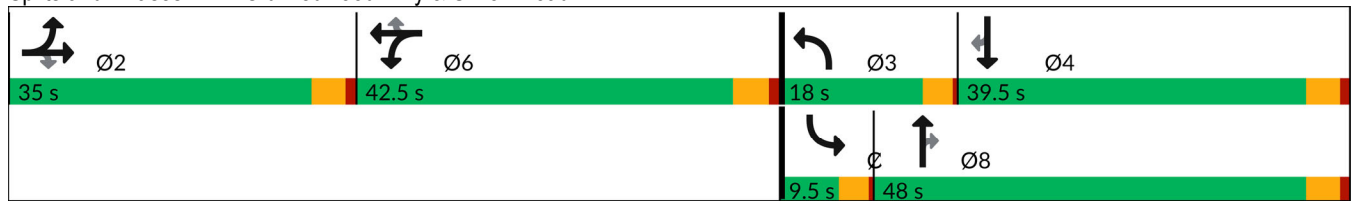

















Splits and Phases: 1: Old Redwood Hwy & Shiloh Road



Lanes, Volumes, Timings  
2: Shiloh Road & Hembree Ln

2028 Opening Year Alter. B Project Conditions

Timing Plan: P.M. Peak

												
Lane Group	EBL	EBT	EBR	WBL	WBT	WBR	NBL	NBT	NBR	SBL	SBT	SBR
Lane Configurations												
Traffic Volume (vph)	615	725	44	24	601	145	65	11	15	170	11	497
Future Volume (vph)	615	725	44	24	601	145	65	11	15	170	11	497
Ideal Flow (vphpl)	1900	1900	1900	1900	1900	1900	1900	1900	1900	1900	1900	1900
Storage Length (ft)	0		0	100		130	0		0	0		0
Storage Lanes	2		0	1		1	1		0	0		1
Taper Length (ft)	25			50			25			25		
Lane Util. Factor	0.97	1.00	1.00	1.00	0.95	0.95	1.00	1.00	1.00	1.00	1.00	1.00
Ped Bike Factor	1.00				1.00							
Frt		0.992			0.971			0.913				0.850
Flt Protected	0.950			0.950			0.950				0.955	
Satd. Flow (prot)	3433	1848	0	1770	3428	0	1770	1701	0	0	1779	1583
Flt Permitted	0.950			0.950			0.950				0.955	
Satd. Flow (perm)	3431	1848	0	1770	3428	0	1770	1701	0	0	1779	1583
Right Turn on Red			Yes			Yes			Yes			Yes
Satd. Flow (RTOR)		6			43			15				165
Link Speed (mph)		40			40			30				35
Link Distance (ft)		302			1789			216				381
Travel Time (s)		5.1			30.5			4.9				7.4
Confl. Peds. (#/hr)	2					2						
Peak Hour Factor	0.94	0.94	1.00	1.00	0.87	0.87	1.00	1.00	1.00	0.95	1.00	0.95
Adj. Flow (vph)	654	771	44	24	691	167	65	11	15	179	11	523
Shared Lane Traffic (%)												
Lane Group Flow (vph)	654	815	0	24	858	0	65	26	0	0	190	523
Enter Blocked Intersection	No	No	No	No	No	No	No	No	No	No	No	No
Lane Alignment	Left	Left	Right	Left	Left	Right	Left	Left	Right	Left	Left	Right
Median Width(ft)		24			24			12				12
Link Offset(ft)		0			0			0				0
Crosswalk Width(ft)		16			16			16				16
Two way Left Turn Lane												
Headway Factor	1.00	1.00	1.00	1.00	1.00	1.00	1.00	1.00	1.00	1.00	1.00	1.00
Turning Speed (mph)	15		60	60		9	60		60	15		9
Number of Detectors	1	2		1	2		1	2		1	2	1
Detector Template	Left	Thru		Left	Thru		Left	Thru		Left	Thru	Right
Leading Detector (ft)	20	100		20	100		20	100		20	100	20
Trailing Detector (ft)	0	0		0	0		0	0		0	0	0
Detector 1 Position(ft)	0	0		0	0		0	0		0	0	0
Detector 1 Size(ft)	20	6		20	6		20	6		20	6	20
Detector 1 Type	Cl+Ex	Cl+Ex		Cl+Ex	Cl+Ex		Cl+Ex	Cl+Ex		Cl+Ex	Cl+Ex	Cl+Ex
Detector 1 Channel												
Detector 1 Extend (s)	0.0	0.0		0.0	0.0		0.0	0.0		0.0	0.0	0.0
Detector 1 Queue (s)	0.0	0.0		0.0	0.0		0.0	0.0		0.0	0.0	0.0
Detector 1 Delay (s)	0.0	0.0		0.0	0.0		0.0	0.0		0.0	0.0	0.0
Detector 2 Position(ft)		94			94			94				94
Detector 2 Size(ft)		6			6			6				6
Detector 2 Type		Cl+Ex			Cl+Ex			Cl+Ex				Cl+Ex
Detector 2 Channel												
Detector 2 Extend (s)		0.0			0.0			0.0				0.0
Turn Type	Prot	NA		Prot	NA		Split	NA		Split	NA	pt+ov

Lanes, Volumes, Timings  
2: Shiloh Road & Hembree Ln

2028 Opening Year Alter. B Project Conditions

Timing Plan: P.M. Peak

Lane Group	EBL	EBT	EBR	WBL	WBT	WBR	NBL	NBT	NBR	SBL	SBT	SBR
Protected Phases	5	2		1	6		8	8		4	4	4 5
Permitted Phases												
Detector Phase	5	2		1	6		8	8		4	4	4 5
Switch Phase												
Minimum Initial (s)	3.0	5.0		5.0	5.0		5.0	5.0		5.0	5.0	
Minimum Split (s)	7.5	9.5		9.5	43.5		9.5	9.5		9.5	9.5	
Total Split (s)	21.0	57.0		9.5	45.5		9.5	9.5		14.0	14.0	
Total Split (%)	23.3%	63.3%		10.6%	50.6%		10.6%	10.6%		15.6%	15.6%	
Maximum Green (s)	17.0	53.0		5.5	41.5		5.5	5.5		10.0	10.0	
Yellow Time (s)	3.0	3.0		3.0	3.0		3.0	3.0		3.0	3.0	
All-Red Time (s)	1.0	1.0		1.0	1.0		1.0	1.0		1.0	1.0	
Lost Time Adjust (s)	0.0	0.0		0.0	0.0		0.0	0.0		0.0	0.0	
Total Lost Time (s)	4.0	4.0		4.0	4.0		4.0	4.0		4.0	4.0	
Lead/Lag	Lead	Lag		Lead	Lag							
Lead-Lag Optimize?	Yes	Yes		Yes	Yes							
Vehicle Extension (s)	3.0	3.0		3.0	3.0		3.0	3.0		3.0	3.0	
Recall Mode	None	None		None	None		None	None		None	None	
Walk Time (s)					7.0							
Flash Don't Walk (s)					32.0							
Pedestrian Calls (#/hr)					1							
Act Effct Green (s)	17.5	44.9		5.7	26.4		5.7	5.7		10.3	29.0	
Actuated g/C Ratio	0.24	0.61		0.08	0.36		0.08	0.08		0.14	0.39	
v/c Ratio	0.80	0.73		0.18	0.68		0.48	0.18		0.77	0.73	
Control Delay (s/veh)	38.9	16.2		40.5	21.7		50.6	27.3		57.0	20.1	
Queue Delay	0.0	0.0		0.0	0.0		0.0	0.0		0.0	0.0	
Total Delay (s/veh)	38.9	16.3		40.5	21.7		50.6	27.3		57.0	20.1	
LOS	D	B		D	C		D	C		E	C	
Approach Delay (s/veh)		26.3			22.2			43.9			30.0	
Approach LOS		C			C			D			C	

Intersection Summary

Area Type:	Other
Cycle Length:	90
Actuated Cycle Length:	73.9
Natural Cycle:	90
Control Type:	Actuated-Uncoordinated
Maximum v/c Ratio:	0.80
Intersection Signal Delay (s/veh):	26.5
Intersection LOS:	C
Intersection Capacity Utilization:	71.7%
ICU Level of Service:	C
Analysis Period (min):	15

Splits and Phases: 2: Shiloh Road & Hembree Ln



Lanes, Volumes, Timings  
 3: US 101 NB Off-Ramp & Shiloh Road

2028 Opening Year Alter. B Project Conditions

Timing Plan: P.M. Peak

	→	↘	↙	←	↖	↗
Lane Group	EBT	EBR	WBL	WBT	NBL	NBR
Lane Configurations	↑↑			↑	↘	↗
Traffic Volume (vph)	521	0	0	805	526	867
Future Volume (vph)	521	0	0	805	526	867
Ideal Flow (vphpl)	1900	1900	1900	1900	1900	1900
Storage Length (ft)		0	0		0	265
Storage Lanes		0	0		1	2
Taper Length (ft)			25		25	
Lane Util. Factor	0.95	1.00	1.00	1.00	1.00	0.88
Frt						0.850
Flt Protected					0.950	
Satd. Flow (prot)	3539	0	0	1863	1770	2787
Flt Permitted					0.950	
Satd. Flow (perm)	3539	0	0	1863	1770	2787
Right Turn on Red		Yes				Yes
Satd. Flow (RTOR)						396
Link Speed (mph)	40			40	30	
Link Distance (ft)	186			371	769	
Travel Time (s)	3.2			6.3	17.5	
Peak Hour Factor	0.94	0.94	0.97	0.97	0.90	0.90
Adj. Flow (vph)	554	0	0	830	584	963
Shared Lane Traffic (%)						
Lane Group Flow (vph)	554	0	0	830	584	963
Enter Blocked Intersection	No	No	No	No	No	No
Lane Alignment	Left	Right	Left	Left	Left	Right
Median Width(ft)	0			0	12	
Link Offset(ft)	0			0	0	
Crosswalk Width(ft)	16			16	16	
Two way Left Turn Lane						
Headway Factor	1.00	1.00	1.00	1.00	1.00	1.00
Turning Speed (mph)		9	15		15	9
Number of Detectors	2			2	1	1
Detector Template	Thru			Thru	Left	Right
Leading Detector (ft)	100			100	20	20
Trailing Detector (ft)	0			0	0	0
Detector 1 Position(ft)	0			0	0	0
Detector 1 Size(ft)	6			6	20	20
Detector 1 Type	Cl+Ex			Cl+Ex	Cl+Ex	Cl+Ex
Detector 1 Channel						
Detector 1 Extend (s)	0.0			0.0	0.0	0.0
Detector 1 Queue (s)	0.0			0.0	0.0	0.0
Detector 1 Delay (s)	0.0			0.0	0.0	0.0
Detector 2 Position(ft)	94			94		
Detector 2 Size(ft)	6			6		
Detector 2 Type	Cl+Ex			Cl+Ex		
Detector 2 Channel						
Detector 2 Extend (s)	0.0			0.0		
Turn Type	NA			NA	Prot	Perm
Protected Phases	2			6	8	
Permitted Phases						8

Lanes, Volumes, Timings  
 3: US 101 NB Off-Ramp & Shiloh Road

2028 Opening Year Alter. B Project Conditions  
 Timing Plan: P.M. Peak



Lane Group	EBT	EBR	WBL	WBT	NBL	NBR
Detector Phase	2			6	8	8
Switch Phase						
Minimum Initial (s)	5.0			5.0	5.0	5.0
Minimum Split (s)	9.0			9.0	9.0	9.0
Total Split (s)	37.0			37.0	35.0	35.0
Total Split (%)	51.4%			51.4%	48.6%	48.6%
Maximum Green (s)	33.0			33.0	31.0	31.0
Yellow Time (s)	3.0			3.0	3.0	3.0
All-Red Time (s)	1.0			1.0	1.0	1.0
Lost Time Adjust (s)	0.0			0.0	0.0	0.0
Total Lost Time (s)	4.0			4.0	4.0	4.0
Lead/Lag						
Lead-Lag Optimize?						
Vehicle Extension (s)	3.0			3.0	3.0	3.0
Recall Mode	None			None	None	None
Act Effect Green (s)	32.3			32.3	27.4	27.4
Actuated g/C Ratio	0.48			0.48	0.40	0.40
v/c Ratio	0.33			0.94	0.82	0.71
Control Delay (s/veh)	12.3			38.4	28.8	12.6
Queue Delay	0.0			0.0	0.0	0.0
Total Delay (s/veh)	12.3			38.4	28.8	12.6
LOS	B			D	C	B
Approach Delay (s/veh)	12.3			38.4	18.8	
Approach LOS	B			D	B	

Intersection Summary

Area Type: Other  
 Cycle Length: 72  
 Actuated Cycle Length: 67.8  
 Natural Cycle: 65  
 Control Type: Actuated-Uncoordinated  
 Maximum v/c Ratio: 0.94  
 Intersection Signal Delay (s/veh): 23.1  
 Intersection LOS: C  
 Intersection Capacity Utilization 127.1%  
 ICU Level of Service H  
 Analysis Period (min) 15

Splits and Phases: 3: US 101 NB Off-Ramp & Shiloh Road

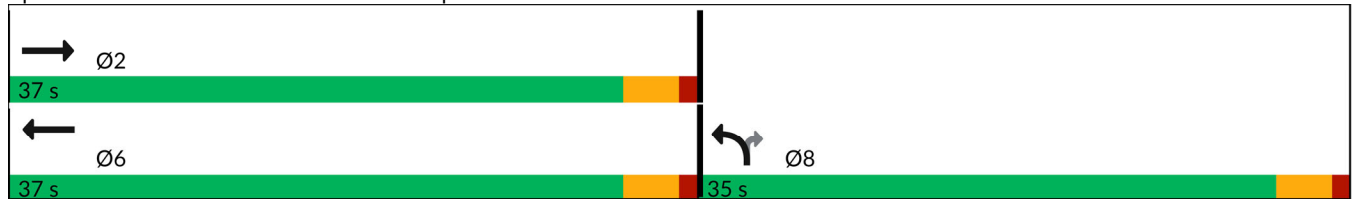

Lanes, Volumes, Timings  
4: Shiloh Road & US 101 SB Off-Ramp

2028 Opening Year Alter. B Project Conditions

Timing Plan: P.M. Peak

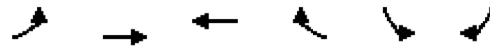

Lane Group	EBL	EBT	WBT	WBR	SBL	SBR
Lane Configurations		↑	↑		↓	↓
Traffic Volume (vph)	0	461	650	0	235	131
Future Volume (vph)	0	461	650	0	235	131
Ideal Flow (vphp)	1900	1900	1900	1900	1900	1900
Storage Length (ft)	0			0	0	275
Storage Lanes	0			0	1	1
Taper Length (ft)	25				25	
Lane Util. Factor	1.00	1.00	1.00	1.00	1.00	1.00
Ped Bike Factor						0.98
Frt						0.850
Flt Protected					0.950	
Satd. Flow (prot)	0	1863	1863	0	1770	1583
Flt Permitted					0.950	
Satd. Flow (perm)	0	1863	1863	0	1770	1548
Right Turn on Red				Yes		Yes
Satd. Flow (RTOR)						141
Link Speed (mph)		40	40		30	
Link Distance (ft)		225	306		486	
Travel Time (s)		3.8	5.2		11.0	
Confl. Peds. (#/hr)						1
Peak Hour Factor	0.89	0.89	0.96	0.96	0.93	0.93
Adj. Flow (vph)	0	518	677	0	253	141
Shared Lane Traffic (%)						
Lane Group Flow (vph)	0	518	677	0	253	141
Enter Blocked Intersection	No	No	No	No	No	No
Lane Alignment	Left	Left	Left	Right	Left	Right
Median Width(ft)		4	0		12	
Link Offset(ft)		0	0		0	
Crosswalk Width(ft)		16	16		16	
Two way Left Turn Lane						
Headway Factor	1.00	1.00	1.00	1.00	1.00	1.00
Turning Speed (mph)	15			9	15	9
Number of Detectors		2	2		1	1
Detector Template		Thru	Thru		Left	Right
Leading Detector (ft)		100	100		20	20
Trailing Detector (ft)		0	0		0	0
Detector 1 Position(ft)		0	0		0	0
Detector 1 Size(ft)		6	6		20	20
Detector 1 Type		Cl+Ex	Cl+Ex		Cl+Ex	Cl+Ex
Detector 1 Channel						
Detector 1 Extend (s)		0.0	0.0		0.0	0.0
Detector 1 Queue (s)		0.0	0.0		0.0	0.0
Detector 1 Delay (s)		0.0	0.0		0.0	0.0
Detector 2 Position(ft)		94	94			
Detector 2 Size(ft)		6	6			
Detector 2 Type		Cl+Ex	Cl+Ex			
Detector 2 Channel						
Detector 2 Extend (s)		0.0	0.0			
Turn Type		NA	NA		Perm	Perm

Lanes, Volumes, Timings  
4: Shiloh Road & US 101 SB Off-Ramp

2028 Opening Year Alter. B Project Conditions  
Timing Plan: P.M. Peak

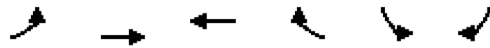

Lane Group	EBL	EBT	WBT	WBR	SBL	SBR
Protected Phases		2	6			
Permitted Phases					4	4
Detector Phase		2	6		4	4
Switch Phase						
Minimum Initial (s)		5.0	5.0		5.0	5.0
Minimum Split (s)		9.0	38.0		9.0	9.0
Total Split (s)		69.0	69.0		21.0	21.0
Total Split (%)		76.7%	76.7%		23.3%	23.3%
Maximum Green (s)		65.0	65.0		17.0	17.0
Yellow Time (s)		3.0	3.0		3.0	3.0
All-Red Time (s)		1.0	1.0		1.0	1.0
Lost Time Adjust (s)		0.0	0.0		0.0	0.0
Total Lost Time (s)		4.0	4.0		4.0	4.0
Lead/Lag						
Lead-Lag Optimize?						
Vehicle Extension (s)		3.0	3.0		3.0	3.0
Recall Mode		None	None		None	None
Walk Time (s)			7.0			
Flash Don't Walk (s)			27.0			
Pedestrian Calls (#/hr)			0			
Act Effct Green (s)		22.3	22.3		12.0	12.0
Actuated g/C Ratio		0.52	0.52		0.28	0.28
v/c Ratio		0.53	0.70		0.51	0.26
Control Delay (s/veh)		9.2	12.3		18.7	5.0
Queue Delay		0.0	0.0		0.0	0.0
Total Delay (s/veh)		9.2	12.3		18.7	5.0
LOS		A	B		B	A
Approach Delay (s/veh)		9.2	12.3		13.8	
Approach LOS		A	B		B	

Intersection Summary

Area Type:	Other
Cycle Length:	90
Actuated Cycle Length:	42.8
Natural Cycle:	55
Control Type:	Actuated-Uncoordinated
Maximum v/c Ratio:	0.70
Intersection Signal Delay (s/veh):	11.7
Intersection LOS:	B
Intersection Capacity Utilization:	116.3%
ICU Level of Service:	H
Analysis Period (min):	15

Splits and Phases: 4: Shiloh Road & US 101 SB Off-Ramp

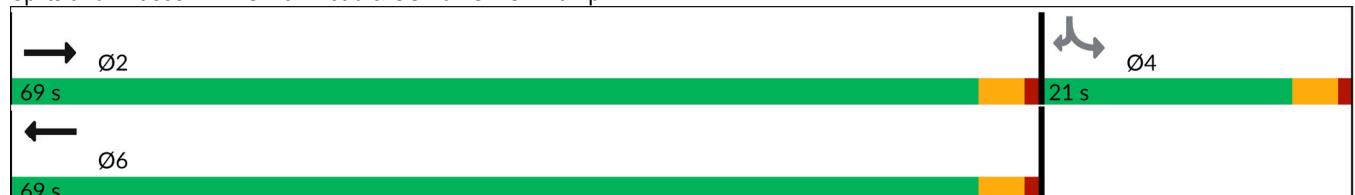

Lanes, Volumes, Timings  
5: Caletti Ave & Shiloh Road

2028 Opening Year Alter. B Project Conditions

Timing Plan: P.M. Peak



















	→	↘	↙	←	↖	↗
Lane Group	EBT	EBR	WBL	WBT	NBL	NBR
Lane Configurations	↑↑		↘	↑	↘	↗
Traffic Volume (vph)	873	28	79	672	15	149
Future Volume (vph)	873	28	79	672	15	149
Ideal Flow (vphpl)	1900	1900	1900	1900	1900	1900
Storage Length (ft)		0	68		0	0
Storage Lanes		0	1		1	1
Taper Length (ft)			50		25	
Lane Util. Factor	0.95	0.95	1.00	1.00	1.00	1.00
Frt	0.995					0.850
Flt Protected			0.950		0.950	
Satd. Flow (prot)	3522	0	1770	1863	1770	1583
Flt Permitted			0.950		0.950	
Satd. Flow (perm)	3522	0	1770	1863	1770	1583
Link Speed (mph)	40			40	30	
Link Distance (ft)	1081			184	459	
Travel Time (s)	18.4			3.1	10.4	
Peak Hour Factor	0.89	0.89	0.92	0.92	0.89	0.89
Adj. Flow (vph)	981	31	86	730	17	167
Shared Lane Traffic (%)						
Lane Group Flow (vph)	1012	0	86	730	17	167
Enter Blocked Intersection	No	No	No	No	No	No
Lane Alignment	Left	Right	Left	Left	Left	Right
Median Width(ft)	12			12	12	
Link Offset(ft)	0			0	0	
Crosswalk Width(ft)	16			16	16	
Two way Left Turn Lane						
Headway Factor	1.00	1.00	1.00	1.00	1.00	1.00
Turning Speed (mph)		9	15		15	9
Sign Control	Free			Free	Stop	
<b>Intersection Summary</b>						
Area Type:	Other					
Control Type:	Unsignalized					
Intersection Capacity Utilization	45.4%			ICU Level of Service A		
Analysis Period (min)	15					



Lanes, Volumes, Timings  
6: Conde Lane & Shiloh Road

2028 Opening Year Alter. B Project Conditions

Timing Plan: P.M. Peak

												
Lane Group	EBL	EBT	EBR	WBL	WBT	WBR	NBL	NBT	NBR	SBL	SBT	SBR
Lane Configurations												
Traffic Volume (vph)	69	492	2	7	477	289	5	3	17	297	0	39
Future Volume (vph)	69	492	2	7	477	289	5	3	17	297	0	39
Ideal Flow (vphpl)	1900	1900	1900	1900	1900	1900	1900	1900	1900	1900	1900	1900
Storage Length (ft)	90		0	127		0	0		0	0		40
Storage Lanes	1		0	1		0	0		0	0		1
Taper Length (ft)	70			40			25			25		
Lane Util. Factor	1.00	0.95	0.95	1.00	0.95	0.95	1.00	1.00	1.00	1.00	1.00	1.00
Ped Bike Factor	1.00				0.99							
Frt		0.999			0.943			0.909				0.850
Flt Protected	0.950			0.950				0.990			0.950	
Satd. Flow (prot)	1770	3536	0	1770	3311	0	0	1676	0	0	1770	1583
Flt Permitted	0.950			0.950				0.990			0.950	
Satd. Flow (perm)	1767	3536	0	1770	3311	0	0	1676	0	0	1770	1583
Right Turn on Red			Yes			Yes			Yes			No
Satd. Flow (RTOR)					132			27				
Link Speed (mph)		40			40			30				35
Link Distance (ft)		815			1081			418				522
Travel Time (s)		13.9			18.4			9.5				10.2
Confl. Peds. (#/hr)	1						1					
Peak Hour Factor	0.88	0.88	0.88	0.80	0.80	0.80	0.63	0.63	0.63	0.88	0.88	0.88
Adj. Flow (vph)	78	559	2	9	596	361	8	5	27	338	0	44
Shared Lane Traffic (%)												
Lane Group Flow (vph)	78	561	0	9	957	0	0	40	0	0	338	44
Enter Blocked Intersection	No	No	No	No	No	No	No	No	No	No	No	No
Lane Alignment	Left	Left	Right	Left	Left	Right	Left	Left	Right	Left	Left	Right
Median Width(ft)		12			12			0			0	
Link Offset(ft)		0			0			0			0	
Crosswalk Width(ft)		16			16			16			16	
Two way Left Turn Lane												
Headway Factor	1.00	1.00	1.00	1.00	1.00	1.00	1.00	1.00	1.00	1.00	1.00	1.00
Turning Speed (mph)	15		9	15		9	15		9	15		9
Number of Detectors	1	2		1	2		1	2		1	1	1
Detector Template	Left	Thru		Left	Thru		Left	Thru		Left	Thru	Right
Leading Detector (ft)	20	100		20	100		20	100		20	30	20
Trailing Detector (ft)	0	0		0	0		0	0		0	0	0
Detector 1 Position(ft)	0	0		0	0		0	0		0	0	0
Detector 1 Size(ft)	20	6		20	6		20	6		20	30	20
Detector 1 Type	Cl+Ex	Cl+Ex		Cl+Ex	Cl+Ex		Cl+Ex	Cl+Ex		Cl+Ex	Cl+Ex	Cl+Ex
Detector 1 Channel												
Detector 1 Extend (s)	0.0	0.0		0.0	0.0		0.0	0.0		0.0	0.0	0.0
Detector 1 Queue (s)	0.0	0.0		0.0	0.0		0.0	0.0		0.0	0.0	0.0
Detector 1 Delay (s)	0.0	0.0		0.0	0.0		0.0	0.0		0.0	0.0	0.0
Detector 2 Position(ft)		94			94			94				
Detector 2 Size(ft)		6			6			6				
Detector 2 Type		Cl+Ex			Cl+Ex			Cl+Ex				
Detector 2 Channel												
Detector 2 Extend (s)		0.0			0.0			0.0				
Turn Type	Prot	NA		Prot	NA		Split	NA		Split	NA	custom

Lanes, Volumes, Timings  
6: Conde Lane & Shiloh Road

2028 Opening Year Alter. B Project Conditions

Timing Plan: P.M. Peak

Lane Group	EBL	EBT	EBR	WBL	WBT	WBR	NBL	NBT	NBR	SBL	SBT	SBR
Protected Phases	5	2		1	6		7	7		4	4	
Permitted Phases												6
Detector Phase	5	2		1	6		7	7		4	4	6
Switch Phase												
Minimum Initial (s)	8.0	8.0		8.0	8.0		10.0	10.0		11.0	11.0	8.0
Minimum Split (s)	12.0	46.0		12.0	12.0		37.0	37.0		15.0	15.0	12.0
Total Split (s)	13.0	46.0		12.0	45.0		37.0	37.0		15.0	15.0	45.0
Total Split (%)	11.8%	41.8%		10.9%	40.9%		33.6%	33.6%		13.6%	13.6%	40.9%
Maximum Green (s)	9.0	42.0		8.0	41.0		33.0	33.0		11.0	11.0	41.0
Yellow Time (s)	3.0	3.0		3.0	3.0		3.0	3.0		3.0	3.0	3.0
All-Red Time (s)	1.0	1.0		1.0	1.0		1.0	1.0		1.0	1.0	1.0
Lost Time Adjust (s)	0.0	0.0		0.0	0.0		0.0	0.0		0.0	0.0	0.0
Total Lost Time (s)	4.0	4.0		4.0	4.0		4.0	4.0		4.0	4.0	4.0
Lead/Lag	Lead	Lag		Lead	Lag							Lag
Lead-Lag Optimize?	Yes	Yes		Yes	Yes							Yes
Vehicle Extension (s)	3.0	3.0		3.0	3.0		3.0	3.0		3.0	3.0	3.0
Recall Mode	None	None		None	None		None	None		None	None	None
Walk Time (s)		7.0					7.0	7.0				
Flash Don't Walk (s)		35.0					26.0	26.0				
Pedestrian Calls (#/hr)		0					0	0				
Act Effct Green (s)	9.5	31.5		9.0	24.1		11.3	11.3		12.4	12.4	24.1
Actuated g/C Ratio	0.15	0.51		0.15	0.39		0.18	0.18		0.20	0.20	0.39
v/c Ratio	0.29	0.31		0.03	0.70		0.12	0.12		0.95	0.95	0.07
Control Delay (s/veh)	33.5	10.3		32.1	17.6		17.8	17.8		72.3	72.3	14.3
Queue Delay	0.0	0.0		0.0	0.0		0.0	0.0		0.0	0.0	0.0
Total Delay (s/veh)	33.5	10.3		32.1	17.6		17.8	17.8		72.3	72.3	14.3
LOS	C	B		C	B		B	B		E	E	B
Approach Delay (s/veh)		13.1			17.8		17.8	17.8		65.6	65.6	
Approach LOS		B			B		B	B		E	E	

Intersection Summary

Area Type:	Other
Cycle Length:	110
Actuated Cycle Length:	61.7
Natural Cycle:	120
Control Type:	Actuated-Uncoordinated
Maximum v/c Ratio:	0.95
Intersection Signal Delay (s/veh):	25.3
Intersection LOS:	C
Intersection Capacity Utilization:	62.3%
ICU Level of Service:	B
Analysis Period (min):	15



















Splits and Phases: 6: Conde Lane & Shiloh Road



Lanes, Volumes, Timings  
7: Driveway 1/Gridley Drive & Shiloh Road

2028 Opening Year Alter. B Project Conditions

Timing Plan: P.M. Peak





















												
Lane Group	EBL	EBT	EBR	WBL	WBT	WBR	NBL	NBT	NBR	SBL	SBT	SBR
Lane Configurations												
Traffic Volume (vph)	17	336	76	0	341	0	71	0	0	0	0	14
Future Volume (vph)	17	336	76	0	341	0	71	0	0	0	0	14
Ideal Flow (vphp)	1900	1900	1900	1900	1900	1900	1900	1900	1900	1900	1900	1900
Storage Length (ft)	0		150	0		0	0		0	0		0
Storage Lanes	0		1	0		0	1		0	0		0
Taper Length (ft)	25			25			25			25		
Lane Util. Factor	1.00	1.00	1.00	1.00	1.00	1.00	1.00	1.00	1.00	1.00	1.00	1.00
Ped Bike Factor												
Frt			0.850								0.865	
Flt Protected		0.998					0.950					
Satd. Flow (prot)	0	1859	1583	0	1863	0	1770	1863	0	0	1611	0
Flt Permitted		0.998					0.950					
Satd. Flow (perm)	0	1859	1583	0	1863	0	1770	1863	0	0	1611	0
Link Speed (mph)		40			40			30			30	
Link Distance (ft)		608			2146			248			715	
Travel Time (s)		10.4			36.6			5.6			16.3	
Confl. Peds. (#/hr)	1											
Confl. Bikes (#/hr)			1									
Peak Hour Factor	0.94	0.94	0.94	0.69	0.69	0.69	1.00	1.00	1.00	0.58	0.58	0.58
Adj. Flow (vph)	18	357	81	0	494	0	71	0	0	0	0	24
Shared Lane Traffic (%)												
Lane Group Flow (vph)	0	375	81	0	494	0	71	0	0	0	24	0
Enter Blocked Intersection	No	No	No	No	No	No	No	No	No	No	No	No
Lane Alignment	Left	Left	Right	Left	Left	Right	Left	Left	Right	Left	Left	Right
Median Width(ft)		0			0			12			12	
Link Offset(ft)		0			0			0			0	
Crosswalk Width(ft)		16			16			16			16	
Two way Left Turn Lane												
Headway Factor	1.00	1.00	1.00	1.00	1.00	1.00	1.00	1.00	1.00	1.00	1.00	1.00
Turning Speed (mph)	15		9	15		9	15		9	15		9
Sign Control		Free			Free			Stop			Stop	

Intersection Summary	
Area Type:	Other
Control Type:	Unsignalized
Intersection Capacity Utilization	48.8%
Analysis Period (min)	15
	ICU Level of Service A

Lanes, Volumes, Timings  
8: Old Redwood Hwy & Driveway 2

2028 Opening Year Alter. B Project Conditions

Timing Plan: P.M. Peak

												
Lane Group	EBL	EBT	EBR	WBL	WBT	WBR	NBL	NBT	NBR	SBL	SBT	SBR
Lane Configurations												
Traffic Volume (vph)	3	0	0	41	0	66	0	505	45	72	427	0
Future Volume (vph)	3	0	0	41	0	66	0	505	45	72	427	0
Ideal Flow (vphp)	1900	1900	1900	1900	1900	1900	1900	1900	1900	1900	1900	1900
Storage Length (ft)	0		0	0		0	0		100	50		0
Storage Lanes	0		0	1		0	0		1	1		0
Taper Length (ft)	25			25			25			25		
Lane Util. Factor	1.00	1.00	1.00	1.00	1.00	1.00	1.00	1.00	1.00	1.00	1.00	1.00
Ped Bike Factor												
Frt					0.850				0.850			
Flt Protected		0.950		0.950						0.950		
Satd. Flow (prot)	0	1770	0	1770	1583	0	0	1863	1583	1770	1863	0
Flt Permitted		0.950		0.950						0.950		
Satd. Flow (perm)	0	1770	0	1770	1583	0	0	1863	1583	1770	1863	0
Link Speed (mph)		30			30			45			45	
Link Distance (ft)		98			385			520			748	
Travel Time (s)		2.2			8.8			7.9			11.3	
Confl. Bikes (#/hr)									3			5
Peak Hour Factor	0.38	0.38	0.38	1.00	1.00	1.00	0.91	0.91	0.91	0.94	0.94	0.94
Adj. Flow (vph)	8	0	0	41	0	66	0	555	49	77	454	0
Shared Lane Traffic (%)												
Lane Group Flow (vph)	0	8	0	41	66	0	0	555	49	77	454	0
Enter Blocked Intersection	No	No	No	No	No	No	No	No	No	No	No	No
Lane Alignment	Left	Left	Right	Left	Left	Right	Left	Left	Right	Left	Left	Right
Median Width(ft)		12			12			12			12	
Link Offset(ft)		0			0			0			0	
Crosswalk Width(ft)		16			16			16			16	
Two way Left Turn Lane												
Headway Factor	1.00	1.00	1.00	1.00	1.00	1.00	1.00	1.00	1.00	1.00	1.00	1.00
Turning Speed (mph)	15		9	15		9	15		9	15		9
Sign Control		Stop			Stop			Free			Free	
<b>Intersection Summary</b>												
Area Type:	Other											
Control Type:	Unsignalized											
Intersection Capacity Utilization	63.1%						ICU Level of Service B					
Analysis Period (min)	15											

Lanes, Volumes, Timings  
9: Driveway 3 & Shiloh Road

2028 Opening Year Alter. B Project Conditions

Timing Plan: P.M. Peak

	→	↘	↙	←	↖	↗
Lane Group	EBT	EBR	WBL	WBT	NBL	NBR
Lane Configurations	↑	↗		↖	↘	↗
Traffic Volume (vph)	81	233	22	111	216	21
Future Volume (vph)	81	233	22	111	216	21
Ideal Flow (vphpl)	1900	1900	1900	1900	1900	1900
Storage Length (ft)		200	0		0	0
Storage Lanes		1	0		1	1
Taper Length (ft)			25		25	
Lane Util. Factor	1.00	1.00	1.00	1.00	1.00	1.00
Frt		0.850				0.850
Flt Protected				0.992	0.950	
Satd. Flow (prot)	1863	1583	0	1848	1770	1583
Flt Permitted				0.992	0.950	
Satd. Flow (perm)	1863	1583	0	1848	1770	1583
Link Speed (mph)	40			40	30	
Link Distance (ft)	2146			134	402	
Travel Time (s)	36.6			2.3	9.1	
Peak Hour Factor	0.92	0.92	0.68	0.68	1.00	1.00
Adj. Flow (vph)	88	253	32	163	216	21
Shared Lane Traffic (%)						
Lane Group Flow (vph)	88	253	0	195	216	21
Enter Blocked Intersection	No	No	No	No	No	No
Lane Alignment	Left	Right	Left	Left	Left	Right
Median Width(ft)	0			0	12	
Link Offset(ft)	0			0	0	
Crosswalk Width(ft)	16			16	16	
Two way Left Turn Lane						
Headway Factor	1.00	1.00	1.00	1.00	1.00	1.00
Turning Speed (mph)		9	15		15	9
Sign Control	Free			Free	Stop	

Intersection Summary

Area Type:	Other
Control Type:	Unsignalized
Intersection Capacity Utilization	32.4%
ICU Level of Service	A
Analysis Period (min)	15

Lanes, Volumes, Timings

2028 Opening Year Alter. B Project Conditions

10: US 101 NB Off Ramp/Lakewood Drive & Old Redwood Highway

Timing Plan: P.M. Peak



Lane Group	EBL	EBT	EBR	WBL	WBT	WBR	NBL	NBT	NBR	SBL	SBT	SBR
Lane Configurations												
Traffic Volume (vph)	261	395	0	0	538	192	500	412	251	249	0	577
Future Volume (vph)	261	395	0	0	538	192	500	412	251	249	0	577
Ideal Flow (vphpl)	1900	1900	1900	1900	1900	1900	1900	1900	1900	1900	1900	1900
Storage Length (ft)	155		0	0		0	270		150	120		0
Storage Lanes	1		0	0		0	1		1	1		1
Taper Length (ft)	50			25			165			75		
Lane Util. Factor	0.97	1.00	1.00	1.00	0.95	0.95	0.91	0.91	0.95	0.97	1.00	1.00
Ped Bike Factor	1.00				0.99			0.99		1.00		
Fr <sub>t</sub>					0.961			0.951				0.850
Fl <sub>t</sub> Protected	0.950						0.950	0.993		0.950		
Satd. Flow (prot)	3433	1863	0	0	3382	0	1610	3181	0	3433	0	1583
Fl <sub>t</sub> Permitted	0.950						0.950	0.993		0.950		
Satd. Flow (perm)	3427	1863	0	0	3382	0	1610	3181	0	3420	0	1583
Right Turn on Red			Yes			Yes			Yes			Yes
Satd. Flow (RTOR)					57			85				286
Link Speed (mph)		35			35			30				30
Link Distance (ft)		226			617			716				478
Travel Time (s)		4.4			12.0			16.3				10.9
Confl. Peds. (#/hr)	3		1	1		3			8	8		
Confl. Bikes (#/hr)			2			9						
Peak Hour Factor	0.87	0.87	0.87	0.91	0.91	0.91	0.92	0.92	0.92	0.96	0.96	0.96
Adj. Flow (vph)	300	454	0	0	591	211	543	448	273	259	0	601
Shared Lane Traffic (%)							22%					
Lane Group Flow (vph)	300	454	0	0	802	0	424	840	0	259	0	601
Enter Blocked Intersection	No	No	No	No	No	No	No	No	No	No	No	No
Lane Alignment	Left	Left	Right	Left	Left	Right	Left	Left	Right	Left	Left	Right
Median Width(ft)		24			24			24				24
Link Offset(ft)		0			0			0				0
Crosswalk Width(ft)		16			16			16				16
Two way Left Turn Lane												
Headway Factor	1.00	1.00	1.00	1.00	1.00	1.00	1.00	1.00	1.00	1.00	1.00	1.00
Turning Speed (mph)	15		9	15		9	15		9	15		9
Number of Detectors	1	2			2		1	2		1		1
Detector Template	Left	Thru			Thru		Left	Thru		Left		Right
Leading Detector (ft)	20	100			100		20	100		20		20
Trailing Detector (ft)	0	0			0		0	0		0		0
Detector 1 Position(ft)	0	0			0		0	0		0		0
Detector 1 Size(ft)	20	6			6		20	6		20		20
Detector 1 Type	Cl+Ex	Cl+Ex			Cl+Ex		Cl+Ex	Cl+Ex		Cl+Ex		Cl+Ex
Detector 1 Channel												
Detector 1 Extend (s)	0.0	0.0			0.0		0.0	0.0		0.0		0.0
Detector 1 Queue (s)	0.0	0.0			0.0		0.0	0.0		0.0		0.0
Detector 1 Delay (s)	0.0	0.0			0.0		0.0	0.0		0.0		0.0
Detector 2 Position(ft)		94			94			94				
Detector 2 Size(ft)		6			6			6				
Detector 2 Type		Cl+Ex			Cl+Ex			Cl+Ex				
Detector 2 Channel												
Detector 2 Extend (s)		0.0			0.0			0.0				

Lanes, Volumes, Timings

2028 Opening Year Alter. B Project Conditions

10: US 101 NB Off Ramp/Lakewood Drive & Old Redwood Highway

Timing Plan: P.M. Peak



Lane Group	EBL	EBT	EBR	WBL	WBT	WBR	NBL	NBT	NBR	SBL	SBT	SBR
Turn Type	Prot	NA			NA		Split	NA		Prot		pm+ov
Protected Phases	5	2			6		8	8		7		5
Permitted Phases												5 8
Detector Phase	5	2			6		8	8		7		5
Switch Phase												
Minimum Initial (s)	7.0	10.0			10.0		10.0	10.0		7.0		7.0
Minimum Split (s)	11.0	32.1			32.1		33.7	33.7		11.0		11.0
Total Split (s)	13.0	45.3			32.3		33.7	33.7		11.0		13.0
Total Split (%)	14.4%	50.3%			35.9%		37.4%	37.4%		12.2%		14.4%
Maximum Green (s)	9.0	40.2			27.2		29.0	29.0		7.0		9.0
Yellow Time (s)	3.0	4.1			4.1		3.7	3.7		3.0		3.0
All-Red Time (s)	1.0	1.0			1.0		1.0	1.0		1.0		1.0
Lost Time Adjust (s)	0.0	0.0			0.0		0.0	0.0		0.0		0.0
Total Lost Time (s)	4.0	5.1			5.1		4.7	4.7		4.0		4.0
Lead/Lag	Lead				Lag		Lag	Lag		Lead		Lead
Lead-Lag Optimize?	Yes				Yes		Yes	Yes		Yes		Yes
Vehicle Extension (s)	3.0	3.0			3.0		3.0	3.0		3.0		3.0
Recall Mode	None	Max			Max		None	None		None		None
Walk Time (s)		7.0			7.0		7.0	7.0				
Flash Don't Walk (s)		20.0			17.0		22.0	22.0				
Pedestrian Calls (#/hr)		0			0		0	0				
Act Effct Green (s)	9.0	40.2			27.2		27.5	27.5		7.0		41.2
Actuated g/C Ratio	0.10	0.45			0.31		0.31	0.31		0.08		0.47
v/c Ratio	0.86	0.54			0.74		0.85	0.80		0.95		0.68
Control Delay (s/veh)	64.1	20.8			30.8		46.2	31.9		87.1		13.4
Queue Delay	0.0	0.0			0.0		0.0	0.0		0.0		0.0
Total Delay (s/veh)	64.1	20.8			30.8		46.2	31.9		87.1		13.4
LOS	E	C			C		D	C		F		B
Approach Delay (s/veh)		38.0			30.8			36.7				35.6
Approach LOS		D			C			D				D

Intersection Summary

Area Type: Other  
 Cycle Length: 90  
 Actuated Cycle Length: 88.5  
 Natural Cycle: 90  
 Control Type: Actuated-Uncoordinated  
 Maximum v/c Ratio: 0.95  
 Intersection Signal Delay (s/veh): 35.4  
 Intersection LOS: D  
 Intersection Capacity Utilization 91.5%  
 ICU Level of Service F  
 Analysis Period (min) 15

Splits and Phases: 10: US 101 NB Off Ramp/Lakewood Drive & Old Redwood Highway

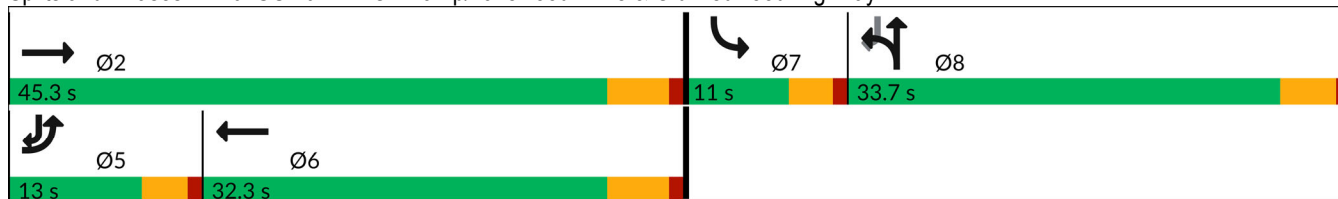

Lanes, Volumes, Timings  
 11: Old Redwood Highway & US 101 NB On Ramp

2028 Opening Year Alter. B Project Conditions

Timing Plan: P.M. Peak

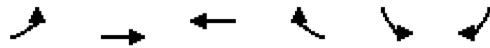

Lane Group	EBL	EBT	WBT	WBR	SBL	SBR
Lane Configurations						
Traffic Volume (vph)	106	650	1403	169	0	0
Future Volume (vph)	106	650	1403	169	0	0
Ideal Flow (vphp)	1900	1900	1900	1900	1900	1900
Storage Length (ft)	245			0	0	0
Storage Lanes	1			0	0	0
Taper Length (ft)	50				25	
Lane Util. Factor	1.00	0.95	0.95	0.95	1.00	1.00
Ped Bike Factor						
Frt			0.984			
Flt Protected	0.950					
Satd. Flow (prot)	1770	3539	3483	0	0	0
Flt Permitted	0.950					
Satd. Flow (perm)	1770	3539	3483	0	0	0
Link Speed (mph)		35	35		30	
Link Distance (ft)		531	226		299	
Travel Time (s)		10.3	4.4		6.8	
Confl. Peds. (#/hr)	17			17		
Confl. Bikes (#/hr)				8		
Peak Hour Factor	0.85	0.85	0.91	0.91	0.25	0.25
Adj. Flow (vph)	125	765	1542	186	0	0
Shared Lane Traffic (%)						
Lane Group Flow (vph)	125	765	1728	0	0	0
Enter Blocked Intersection	No	No	No	No	No	No
Lane Alignment	Left	Left	Left	Right	Left	Right
Median Width(ft)		12	12		0	
Link Offset(ft)		0	0		0	
Crosswalk Width(ft)		16	16		16	
Two way Left Turn Lane						
Headway Factor	1.00	1.00	1.00	1.00	1.00	1.00
Turning Speed (mph)	15			9	15	9
Sign Control		Free	Free		Free	

Intersection Summary

Area Type:	Other
Control Type:	Unsignalized
Intersection Capacity Utilization	66.2%
Analysis Period (min)	15
	ICU Level of Service C



Lanes, Volumes, Timings

2028 Opening Year Alter. B Project Conditions

12: US 101 SB On Ramp/US 101 SB Off Ramp & Old Redwood Highway

Timing Plan: P.M. Peak



Lane Group	EBL	EBT	EBR	WBL	WBT	WBR	NBL	NBT	NBR	SBL	SBT	SBR
Lane Configurations		↑↑	↗	↖	↑↑					↖	↔	
Traffic Volume (vph)	0	535	381	381	1024	0	0	0	0	212	0	129
Future Volume (vph)	0	535	381	381	1024	0	0	0	0	212	0	129
Ideal Flow (vphpl)	1900	1900	1900	1900	1900	1900	1900	1900	1900	1900	1900	1900
Storage Length (ft)	0		0	250		0	0		0	420		0
Storage Lanes	0		1	0		0	0		0	1		0
Taper Length (ft)	25			165			25			75		
Lane Util. Factor	1.00	0.95	1.00	1.00	0.95	1.00	1.00	1.00	1.00	0.95	0.95	1.00
Ped Bike Factor			0.98	1.00								
Frt			0.850								0.881	
Flt Protected				0.950						0.950	0.990	
Satd. Flow (prot)	0	3539	1583	1770	3539	0	0	0	0	1681	1543	0
Flt Permitted				0.950						0.950	0.990	
Satd. Flow (perm)	0	3539	1558	1768	3539	0	0	0	0	1681	1543	0
Right Turn on Red			Yes			Yes			Yes			Yes
Satd. Flow (RTOR)			405								121	
Link Speed (mph)		35			35			30			30	
Link Distance (ft)		423			531			621			831	
Travel Time (s)		8.2			10.3			14.1			18.9	
Confl. Peds. (#/hr)	19		2	2		18						
Confl. Bikes (#/hr)			4			2						
Peak Hour Factor	0.94	0.94	0.94	0.89	0.89	0.89	0.25	0.25	0.25	0.83	0.83	0.83
Adj. Flow (vph)	0	569	405	428	1151	0	0	0	0	255	0	155
Shared Lane Traffic (%)										16%		
Lane Group Flow (vph)	0	569	405	428	1151	0	0	0	0	214	196	0
Enter Blocked Intersection	No	No	No	No	No	No	No	No	No	No	No	No
Lane Alignment	Left	Left	Right	Left	Left	Right	Left	Left	Right	Left	Left	Right
Median Width(ft)		24			24			12			12	
Link Offset(ft)		0			0			0			0	
Crosswalk Width(ft)		16			16			16			16	
Two way Left Turn Lane												
Headway Factor	1.00	1.00	1.00	1.00	1.00	1.00	1.00	1.00	1.00	1.00	1.00	1.00
Turning Speed (mph)	15		9	15		9	15		9	15		9
Number of Detectors		2	1	1	2					1	2	
Detector Template		Thru	Right	Left	Thru					Left	Thru	
Leading Detector (ft)		100	20	20	100					20	100	
Trailing Detector (ft)		0	0	0	0					0	0	
Detector 1 Position(ft)		0	0	0	0					0	0	
Detector 1 Size(ft)		6	20	20	6					20	6	
Detector 1 Type		Cl+Ex	Cl+Ex	Cl+Ex	Cl+Ex					Cl+Ex	Cl+Ex	
Detector 1 Channel												
Detector 1 Extend (s)		0.0	0.0	0.0	0.0					0.0	0.0	
Detector 1 Queue (s)		0.0	0.0	0.0	0.0					0.0	0.0	
Detector 1 Delay (s)		0.0	0.0	0.0	0.0					0.0	0.0	
Detector 2 Position(ft)		94			94							94
Detector 2 Size(ft)		6			6							6
Detector 2 Type		Cl+Ex			Cl+Ex							Cl+Ex
Detector 2 Channel												
Detector 2 Extend (s)		0.0			0.0							0.0

Lanes, Volumes, Timings

2028 Opening Year Alter. B Project Conditions

12: US 101 SB On Ramp/US 101 SB Off Ramp & Old Redwood Highway

Timing Plan: P.M. Peak



Lane Group	EBL	EBT	EBR	WBL	WBT	WBR	NBL	NBT	NBR	SBL	SBT	SBR
Turn Type		NA	Perm	Prot	NA					Perm	NA	
Protected Phases		6		5	2						8	
Permitted Phases			6							8		
Detector Phase		6	6	5	2					8	8	
Switch Phase												
Minimum Initial (s)		10.0	10.0	7.0	10.0					10.0	10.0	
Minimum Split (s)		32.1	32.1	11.0	38.1					14.7	14.7	
Total Split (s)		33.0	33.0	22.0	55.0					15.0	15.0	
Total Split (%)		47.1%	47.1%	31.4%	78.6%					21.4%	21.4%	
Maximum Green (s)		27.9	27.9	18.0	49.9					10.3	10.3	
Yellow Time (s)		4.1	4.1	3.0	4.1					3.7	3.7	
All-Red Time (s)		1.0	1.0	1.0	1.0					1.0	1.0	
Lost Time Adjust (s)		0.0	0.0	0.0	0.0					0.0	0.0	
Total Lost Time (s)		5.1	5.1	4.0	5.1					4.7	4.7	
Lead/Lag		Lag	Lag	Lead								
Lead-Lag Optimize?		Yes	Yes	Yes								
Vehicle Extension (s)		3.0	3.0	3.0	3.0					3.0	3.0	
Recall Mode		Max	Max	None	Max					None	None	
Walk Time (s)		7.0	7.0		7.0							
Flash Don't Walk (s)		20.0	20.0		25.0							
Pedestrian Calls (#/hr)		0	0		0							
Act Effct Green (s)		27.9	27.9	18.0	49.9					10.3	10.3	
Actuated g/C Ratio		0.40	0.40	0.26	0.71					0.15	0.15	
v/c Ratio		0.40	0.47	0.94	0.46					0.87	0.59	
Control Delay (s/veh)		16.2	3.7	58.2	5.0					63.8	20.1	
Queue Delay		0.0	0.0	0.0	0.0					0.0	0.0	
Total Delay (s/veh)		16.2	3.7	58.2	5.0					63.8	20.1	
LOS		B	A	E	A					E	C	
Approach Delay (s/veh)		11.0			19.4						42.9	
Approach LOS		B			B						D	

Intersection Summary

Area Type: Other  
 Cycle Length: 70  
 Actuated Cycle Length: 70  
 Natural Cycle: 70  
 Control Type: Actuated-Uncoordinated  
 Maximum v/c Ratio: 0.94  
 Intersection Signal Delay (s/veh): 19.9  
 Intersection LOS: B  
 Intersection Capacity Utilization 66.2%  
 ICU Level of Service C  
 Analysis Period (min) 15



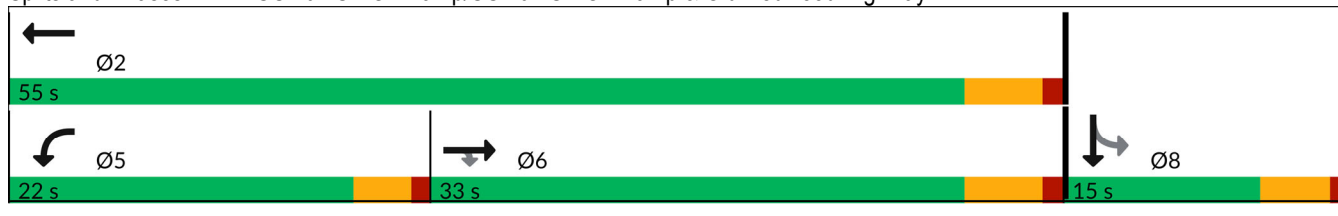



















Splits and Phases: 12: US 101 SB On Ramp/US 101 SB Off Ramp & Old Redwood Highway



Lanes, Volumes, Timings  
1: Old Redwood Hwy & Shiloh Road

2028 Opening Year Alter. B Project Conditions

Timing Plan: Saturday Midday Peak

												
Lane Group	EBL	EBT	EBR	WBL	WBT	WBR	NBL	NBT	NBR	SBL	SBT	SBR
Lane Configurations												
Traffic Volume (vph)	156	453	282	24	488	70	293	279	27	71	228	239
Future Volume (vph)	156	453	282	24	488	70	293	279	27	71	228	239
Ideal Flow (vphpl)	1900	1900	1900	1900	1900	1900	1900	1900	1900	1900	1900	1900
Storage Length (ft)	375		140	0		50	200		98	130		93
Storage Lanes	1		1	0		1	1		1	1		1
Taper Length (ft)	50			25			60			93		
Lane Util. Factor	1.00	1.00	1.00	1.00	1.00	1.00	1.00	1.00	1.00	1.00	1.00	1.00
Ped Bike Factor	1.00		0.98						0.98			0.97
Frt			0.850			0.850			0.850			0.850
Flt Protected	0.950				0.998		0.950			0.950		
Satd. Flow (prot)	1770	1863	1583	0	1859	1583	1770	1863	1583	1770	1863	1583
Flt Permitted	0.950				0.998		0.950			0.950		
Satd. Flow (perm)	1764	1863	1549	0	1859	1583	1770	1863	1550	1770	1863	1540
Right Turn on Red			Yes			Yes			Yes			Yes
Satd. Flow (RTOR)			142			113			81			178
Link Speed (mph)		40			40			45			40	
Link Distance (ft)		1789			608			748			775	
Travel Time (s)		30.5			10.4			11.3			13.2	
Confl. Peds. (#/hr)	4											
Confl. Bikes (#/hr)			1						1			5
Peak Hour Factor	0.89	0.89	0.89	0.86	0.86	0.86	0.93	0.93	0.93	0.91	0.91	0.91
Adj. Flow (vph)	175	509	317	28	567	81	315	300	29	78	251	263
Shared Lane Traffic (%)												
Lane Group Flow (vph)	175	509	317	0	595	81	315	300	29	78	251	263
Enter Blocked Intersection	No	No	No	No	No	No	No	No	No	No	No	No
Lane Alignment	Left	Left	Right	Left	Left	Right	Left	Left	Right	Left	Left	Right
Median Width(ft)		12			12			12			12	
Link Offset(ft)		0			0			0			0	
Crosswalk Width(ft)		16			16			16			16	
Two way Left Turn Lane												
Headway Factor	1.00	1.00	1.00	1.00	1.00	1.00	1.00	1.00	1.00	1.00	1.00	1.00
Turning Speed (mph)	15		9	15		9	15		9	15		9
Number of Detectors	1	2	1	1	2	1	1	2	1	1	2	1
Detector Template	Left	Thru	Right	Left	Thru	Right	Left	Thru	Right	Left	Thru	Right
Leading Detector (ft)	20	100	20	20	100	20	20	100	20	20	100	20
Trailing Detector (ft)	0	0	0	0	0	0	0	0	0	0	0	0
Detector 1 Position(ft)	0	0	0	0	0	0	0	0	0	0	0	0
Detector 1 Size(ft)	20	6	20	20	6	20	20	6	20	20	6	20
Detector 1 Type	Cl+Ex	Cl+Ex	Cl+Ex	Cl+Ex	Cl+Ex	Cl+Ex	Cl+Ex	Cl+Ex	Cl+Ex	Cl+Ex	Cl+Ex	Cl+Ex
Detector 1 Channel												
Detector 1 Extend (s)	0.0	0.0	0.0	0.0	0.0	0.0	0.0	0.0	0.0	0.0	0.0	0.0
Detector 1 Queue (s)	0.0	0.0	0.0	0.0	0.0	0.0	0.0	0.0	0.0	0.0	0.0	0.0
Detector 1 Delay (s)	0.0	0.0	0.0	0.0	0.0	0.0	0.0	0.0	0.0	0.0	0.0	0.0
Detector 2 Position(ft)		94			94			94			94	
Detector 2 Size(ft)		6			6			6			6	
Detector 2 Type		Cl+Ex			Cl+Ex			Cl+Ex			Cl+Ex	
Detector 2 Channel												
Detector 2 Extend (s)		0.0			0.0			0.0			0.0	

Lanes, Volumes, Timings  
1: Old Redwood Hwy & Shiloh Road

2028 Opening Year Alter. B Project Conditions

Timing Plan: Saturday Midday Peak

Lane Group	EBL	EBT	EBR	WBL	WBT	WBR	NBL	NBT	NBR	SBL	SBT	SBR
Turn Type	Split	NA	Perm	Split	NA	Perm	Prot	NA	Perm	Prot	NA	Perm
Protected Phases	2	2		6	6		3	8		7	4	
Permitted Phases			2			6			8			4
Detector Phase	2	2	2	6	6	6	3	8	8	7	4	4
Switch Phase												
Minimum Initial (s)	5.0	5.0	5.0	5.0	5.0	5.0	5.0	5.0	5.0	5.0	5.0	5.0
Minimum Split (s)	34.5	34.5	34.5	42.5	42.5	42.5	9.0	46.5	46.5	9.0	39.5	39.5
Total Split (s)	35.0	35.0	35.0	42.5	42.5	42.5	18.0	48.0	48.0	9.5	39.5	39.5
Total Split (%)	25.9%	25.9%	25.9%	31.5%	31.5%	31.5%	13.3%	35.6%	35.6%	7.0%	29.3%	29.3%
Maximum Green (s)	30.5	30.5	30.5	38.0	38.0	38.0	14.0	43.5	43.5	5.5	35.0	35.0
Yellow Time (s)	3.5	3.5	3.5	3.5	3.5	3.5	3.5	3.5	3.5	3.5	3.5	3.5
All-Red Time (s)	1.0	1.0	1.0	1.0	1.0	1.0	0.5	1.0	1.0	0.5	1.0	1.0
Lost Time Adjust (s)	0.0	0.0	0.0		0.0	0.0	0.0	0.0	0.0	0.0	0.0	0.0
Total Lost Time (s)	4.5	4.5	4.5		4.5	4.5	4.0	4.5	4.5	4.0	4.5	4.5
Lead/Lag	Lead	Lead	Lead	Lag	Lag	Lag	Lead	Lag	Lag	Lead	Lag	Lag
Lead-Lag Optimize?	Yes	Yes	Yes	Yes	Yes	Yes	Yes	Yes	Yes	Yes	Yes	Yes
Vehicle Extension (s)	3.0	3.0	3.0	3.0	3.0	3.0	3.0	3.0	3.0	3.0	3.0	3.0
Recall Mode	None	None	None	None	None	None	None	None	None	None	None	None
Walk Time (s)	7.0	7.0	7.0	7.0	7.0	7.0		7.0	7.0		7.0	7.0
Flash Don't Walk (s)	23.0	23.0	23.0	31.0	31.0	31.0		35.0	35.0		28.0	28.0
Pedestrian Calls (#/hr)	0	0	0	0	0	0		0	0		0	0
Act Effct Green (s)	30.6	30.6	30.6		38.1	38.1	14.0	30.5	30.5	5.5	22.0	22.0
Actuated g/C Ratio	0.25	0.25	0.25		0.31	0.31	0.11	0.25	0.25	0.04	0.18	0.18
v/c Ratio	0.40	1.09	0.64		1.03	0.14	1.55	0.65	0.06	0.99	0.75	0.62
Control Delay (s/veh)	42.7	112.7	29.7		86.9	2.9	307.9	47.6	0.3	155.5	61.5	21.8
Queue Delay	0.0	0.0	0.0		0.0	0.0	0.0	0.0	0.0	0.0	0.0	0.0
Total Delay (s/veh)	42.7	112.7	29.7		86.9	2.9	307.9	47.6	0.3	155.5	61.5	21.8
LOS	D	F	C		F	A	F	D	A	F	E	C
Approach Delay (s/veh)		74.2			76.8			172.8			56.3	
Approach LOS		E			E			F			E	

Intersection Summary

Area Type: Other  
 Cycle Length: 135  
 Actuated Cycle Length: 122.3  
 Natural Cycle: 145  
 Control Type: Actuated-Uncoordinated  
 Maximum v/c Ratio: 1.55  
 Intersection Signal Delay (s/veh): 93.0  
 Intersection LOS: F  
 Intersection Capacity Utilization 93.7%  
 ICU Level of Service F  
 Analysis Period (min) 15



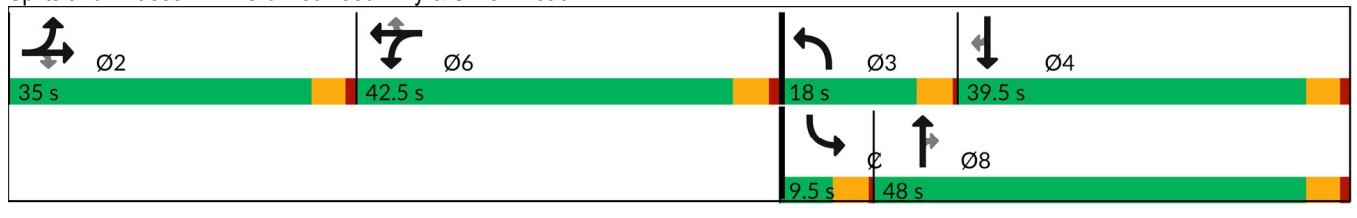

















Splits and Phases: 1: Old Redwood Hwy & Shiloh Road



Lanes, Volumes, Timings  
2: Shiloh Road & Hembree Ln

2028 Opening Year Alter. B Project Conditions

Timing Plan: Saturday Midday Peak

												
Lane Group	EBL	EBT	EBR	WBL	WBT	WBR	NBL	NBT	NBR	SBL	SBT	SBR
Lane Configurations												
Traffic Volume (vph)	708	814	44	24	777	185	65	11	15	182	11	666
Future Volume (vph)	708	814	44	24	777	185	65	11	15	182	11	666
Ideal Flow (vphpl)	1900	1900	1900	1900	1900	1900	1900	1900	1900	1900	1900	1900
Storage Length (ft)	0		0	100		130	0		0	0		0
Storage Lanes	2		0	1		1	1		0	0		1
Taper Length (ft)	25			50			25			25		
Lane Util. Factor	0.97	1.00	1.00	1.00	0.95	0.95	1.00	1.00	1.00	1.00	1.00	1.00
Ped Bike Factor	1.00				1.00							
Frt		0.993			0.971			0.913				0.850
Flt Protected	0.950			0.950			0.950				0.955	
Satd. Flow (prot)	3433	1850	0	1770	3428	0	1770	1701	0	0	1779	1583
Flt Permitted	0.950			0.950			0.950				0.955	
Satd. Flow (perm)	3432	1850	0	1770	3428	0	1770	1701	0	0	1779	1583
Right Turn on Red			Yes			Yes			Yes			Yes
Satd. Flow (RTOR)		5			43			15				126
Link Speed (mph)		40			40			30				35
Link Distance (ft)		302			1789			216				381
Travel Time (s)		5.1			30.5			4.9				7.4
Confl. Peds. (#/hr)	1						1					
Peak Hour Factor	0.94	0.94	1.00	1.00	0.96	0.96	1.00	1.00	1.00	0.91	1.00	0.91
Adj. Flow (vph)	753	866	44	24	809	193	65	11	15	200	11	732
Shared Lane Traffic (%)												
Lane Group Flow (vph)	753	910	0	24	1002	0	65	26	0	0	211	732
Enter Blocked Intersection	No	No	No	No	No	No	No	No	No	No	No	No
Lane Alignment	Left	Left	Right	Left	Left	Right	Left	Left	Right	Left	Left	Right
Median Width(ft)		24			24			12				12
Link Offset(ft)		0			0			0				0
Crosswalk Width(ft)		16			16			16				16
Two way Left Turn Lane												
Headway Factor	1.00	1.00	1.00	1.00	1.00	1.00	1.00	1.00	1.00	1.00	1.00	1.00
Turning Speed (mph)	15		9	15		9	15		9	15		9
Number of Detectors	1	2		1	2		1	2		1	2	1
Detector Template	Left	Thru		Left	Thru		Left	Thru		Left	Thru	Right
Leading Detector (ft)	20	100		20	100		20	100		20	100	20
Trailing Detector (ft)	0	0		0	0		0	0		0	0	0
Detector 1 Position(ft)	0	0		0	0		0	0		0	0	0
Detector 1 Size(ft)	20	6		20	6		20	6		20	6	20
Detector 1 Type	Cl+Ex	Cl+Ex		Cl+Ex	Cl+Ex		Cl+Ex	Cl+Ex		Cl+Ex	Cl+Ex	Cl+Ex
Detector 1 Channel												
Detector 1 Extend (s)	0.0	0.0		0.0	0.0		0.0	0.0		0.0	0.0	0.0
Detector 1 Queue (s)	0.0	0.0		0.0	0.0		0.0	0.0		0.0	0.0	0.0
Detector 1 Delay (s)	0.0	0.0		0.0	0.0		0.0	0.0		0.0	0.0	0.0
Detector 2 Position(ft)		94			94			94				94
Detector 2 Size(ft)		6			6			6				6
Detector 2 Type		Cl+Ex			Cl+Ex			Cl+Ex				Cl+Ex
Detector 2 Channel												
Detector 2 Extend (s)		0.0			0.0			0.0				0.0
Turn Type	Prot	NA		Prot	NA		Split	NA		Split	NA	pt+ov

Lanes, Volumes, Timings  
2: Shiloh Road & Hembree Ln

2028 Opening Year Alter. B Project Conditions

Timing Plan: Saturday Midday Peak

Lane Group	EBL	EBT	EBR	WBL	WBT	WBR	NBL	NBT	NBR	SBL	SBT	SBR
Protected Phases	5	2		1	6		8	8		4	4	4 5
Permitted Phases												
Detector Phase	5	2		1	6		8	8		4	4	4 5
Switch Phase												
Minimum Initial (s)	3.0	5.0		5.0	5.0		5.0	5.0		5.0	5.0	
Minimum Split (s)	7.5	9.5		9.5	43.5		9.5	9.5		9.5	9.5	
Total Split (s)	21.0	57.0		9.5	45.5		9.5	9.5		14.0	14.0	
Total Split (%)	23.3%	63.3%		10.6%	50.6%		10.6%	10.6%		15.6%	15.6%	
Maximum Green (s)	17.0	53.0		5.5	41.5		5.5	5.5		10.0	10.0	
Yellow Time (s)	3.0	3.0		3.0	3.0		3.0	3.0		3.0	3.0	
All-Red Time (s)	1.0	1.0		1.0	1.0		1.0	1.0		1.0	1.0	
Lost Time Adjust (s)	0.0	0.0		0.0	0.0		0.0	0.0		0.0	0.0	
Total Lost Time (s)	4.0	4.0		4.0	4.0		4.0	4.0		4.0	4.0	
Lead/Lag	Lead	Lag		Lead	Lag							
Lead-Lag Optimize?	Yes	Yes		Yes	Yes							
Vehicle Extension (s)	3.0	3.0		3.0	3.0		3.0	3.0		3.0	3.0	
Recall Mode	None	None		None	None		None	None		None	None	
Walk Time (s)					7.0							
Flash Don't Walk (s)					32.0							
Pedestrian Calls (#/hr)					1							
Act Effct Green (s)	17.5	48.7		5.7	30.4		5.7	5.7		10.3	28.8	
Actuated g/C Ratio	0.23	0.63		0.07	0.39		0.07	0.07		0.13	0.37	
v/c Ratio	0.98	0.78		0.19	0.73		0.51	0.19		0.90	1.10	
Control Delay (s/veh)	61.4	18.5		42.4	22.5		54.2	28.4		77.2	87.5	
Queue Delay	0.0	0.2		0.0	0.0		0.0	0.0		0.0	0.0	
Total Delay (s/veh)	61.4	18.7		42.4	22.5		54.2	28.4		77.2	87.5	
LOS	E	B		D	C		D	C		E	F	
Approach Delay (s/veh)		38.0			22.9			46.8			85.2	
Approach LOS		D			C			D			F	

Intersection Summary

Area Type:	Other
Cycle Length:	90
Actuated Cycle Length:	77.7
Natural Cycle:	110
Control Type:	Actuated-Uncoordinated
Maximum v/c Ratio:	1.10
Intersection Signal Delay (s/veh):	46.0
Intersection LOS:	D
Intersection Capacity Utilization:	83.0%
ICU Level of Service:	E
Analysis Period (min):	15

Splits and Phases: 2: Shiloh Road & Hembree Ln

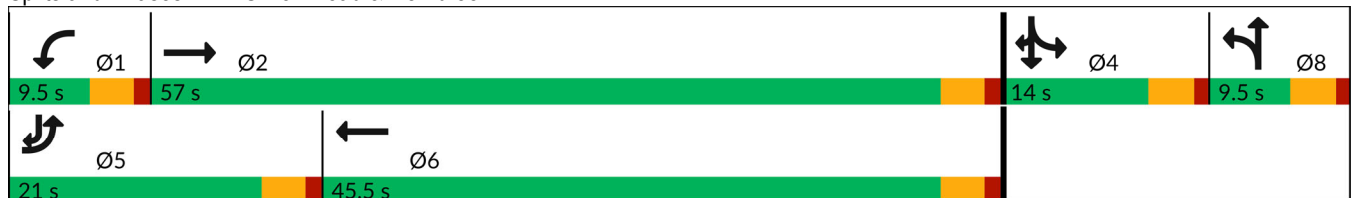

Lanes, Volumes, Timings  
3: US 101 NB Off-Ramp & Shiloh Road

2028 Opening Year Alter. B Project Conditions

Timing Plan: Saturday Midday Peak

	→	↘	↙	←	↖	↗
Lane Group	EBT	EBR	WBL	WBT	NBL	NBR
Lane Configurations	↑↑			↑	↘	↗
Traffic Volume (vph)	624	0	0	1105	401	931
Future Volume (vph)	624	0	0	1105	401	931
Ideal Flow (vphpl)	1900	1900	1900	1900	1900	1900
Storage Length (ft)		0	0		0	265
Storage Lanes		0	0		1	2
Taper Length (ft)			25		25	
Lane Util. Factor	0.95	1.00	1.00	1.00	1.00	0.88
Ped Bike Factor						
Frt						0.850
Flt Protected					0.950	
Satd. Flow (prot)	3539	0	0	1863	1770	2787
Flt Permitted					0.950	
Satd. Flow (perm)	3539	0	0	1863	1770	2787
Right Turn on Red		Yes				Yes
Satd. Flow (RTOR)						383
Link Speed (mph)	40			40	30	
Link Distance (ft)	186			371	769	
Travel Time (s)	3.2			6.3	17.5	
Confl. Bikes (#/hr)		1				
Peak Hour Factor	1.00	1.00	1.00	1.00	1.00	1.00
Adj. Flow (vph)	624	0	0	1105	401	931
Shared Lane Traffic (%)						
Lane Group Flow (vph)	624	0	0	1105	401	931
Enter Blocked Intersection	No	No	No	No	No	No
Lane Alignment	Left	Right	Left	Left	Left	Right
Median Width(ft)	0			0	12	
Link Offset(ft)	0			0	0	
Crosswalk Width(ft)	16			16	16	
Two way Left Turn Lane						
Headway Factor	1.00	1.00	1.00	1.00	1.00	1.00
Turning Speed (mph)		9	15		15	9
Number of Detectors	2			2	1	1
Detector Template	Thru			Thru	Left	Right
Leading Detector (ft)	100			100	20	20
Trailing Detector (ft)	0			0	0	0
Detector 1 Position(ft)	0			0	0	0
Detector 1 Size(ft)	6			6	20	20
Detector 1 Type	Cl+Ex			Cl+Ex	Cl+Ex	Cl+Ex
Detector 1 Channel						
Detector 1 Extend (s)	0.0			0.0	0.0	0.0
Detector 1 Queue (s)	0.0			0.0	0.0	0.0
Detector 1 Delay (s)	0.0			0.0	0.0	0.0
Detector 2 Position(ft)	94			94		
Detector 2 Size(ft)	6			6		
Detector 2 Type	Cl+Ex			Cl+Ex		
Detector 2 Channel						
Detector 2 Extend (s)	0.0			0.0		
Turn Type	NA			NA	Prot	Perm

Lanes, Volumes, Timings  
 3: US 101 NB Off-Ramp & Shiloh Road

2028 Opening Year Alter. B Project Conditions  
 Timing Plan: Saturday Midday Peak

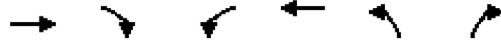

Lane Group	EBT	EBR	WBL	WBT	NBL	NBR
Protected Phases	2			6	8	
Permitted Phases						8
Detector Phase	2			6	8	8
Switch Phase						
Minimum Initial (s)	5.0			5.0	5.0	5.0
Minimum Split (s)	9.5			9.5	9.5	9.5
Total Split (s)	45.0			45.0	35.0	35.0
Total Split (%)	56.3%			56.3%	43.8%	43.8%
Maximum Green (s)	40.5			40.5	30.5	30.5
Yellow Time (s)	3.5			3.5	3.5	3.5
All-Red Time (s)	1.0			1.0	1.0	1.0
Lost Time Adjust (s)	0.0			0.0	0.0	0.0
Total Lost Time (s)	4.5			4.5	4.5	4.5
Lead/Lag						
Lead-Lag Optimize?						
Vehicle Extension (s)	3.0			3.0	3.0	3.0
Recall Mode	None			None	None	None
Act Effct Green (s)	40.8			40.8	23.0	23.0
Actuated g/C Ratio	0.56			0.56	0.32	0.32
v/c Ratio	0.31			1.06	0.72	0.82
Control Delay (s/veh)	10.1			65.6	29.6	19.4
Queue Delay	0.0			0.0	0.0	0.0
Total Delay (s/veh)	10.1			65.6	29.6	19.4
LOS	B			E	C	B
Approach Delay (s/veh)	10.1			65.6	22.4	
Approach LOS	B			E	C	

Intersection Summary

Area Type:	Other
Cycle Length:	80
Actuated Cycle Length:	72.9
Natural Cycle:	90
Control Type:	Actuated-Uncoordinated
Maximum v/c Ratio:	1.06
Intersection Signal Delay (s/veh):	35.5
Intersection LOS:	D
Intersection Capacity Utilization:	149.6%
ICU Level of Service:	H
Analysis Period (min):	15

Splits and Phases: 3: US 101 NB Off-Ramp & Shiloh Road

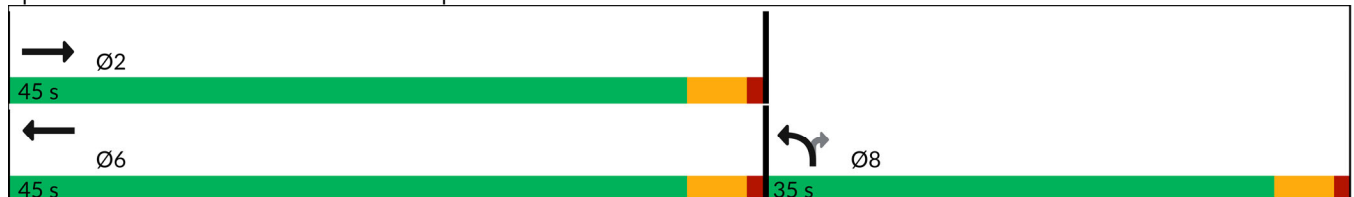



Lanes, Volumes, Timings  
4: Shiloh Road & US 101 SB Off-Ramp

2028 Opening Year Alter. B Project Conditions

Timing Plan: Saturday Midday Peak

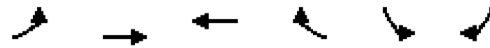

Lane Group	EBL	EBT	WBT	WBR	SBL	SBR
Lane Configurations		↑	↑		↘	↗
Traffic Volume (vph)	0	348	633	0	364	174
Future Volume (vph)	0	348	633	0	364	174
Ideal Flow (vphp)	1900	1900	1900	1900	1900	1900
Storage Length (ft)	0			0	0	275
Storage Lanes	0			0	1	1
Taper Length (ft)	25				25	
Lane Util. Factor	1.00	1.00	1.00	1.00	1.00	1.00
Ped Bike Factor						
Frt						0.850
Flt Protected					0.950	
Satd. Flow (prot)	0	1863	1863	0	1770	1583
Flt Permitted					0.950	
Satd. Flow (perm)	0	1863	1863	0	1770	1583
Right Turn on Red				Yes		Yes
Satd. Flow (RTOR)						256
Link Speed (mph)		40	40		30	
Link Distance (ft)		225	306		486	
Travel Time (s)		3.8	5.2		11.0	
Confl. Bikes (#/hr)				2		
Peak Hour Factor	0.96	0.96	0.96	0.96	0.68	0.68
Adj. Flow (vph)	0	363	659	0	535	256
Shared Lane Traffic (%)						
Lane Group Flow (vph)	0	363	659	0	535	256
Enter Blocked Intersection	No	No	No	No	No	No
Lane Alignment	Left	Left	Left	Right	Left	Right
Median Width(ft)		4	0		12	
Link Offset(ft)		0	0		0	
Crosswalk Width(ft)		16	16		16	
Two way Left Turn Lane						
Headway Factor	1.00	1.00	1.00	1.00	1.00	1.00
Turning Speed (mph)	15			9	15	9
Number of Detectors		2	2		1	1
Detector Template		Thru	Thru		Left	Right
Leading Detector (ft)		100	100		20	20
Trailing Detector (ft)		0	0		0	0
Detector 1 Position(ft)		0	0		0	0
Detector 1 Size(ft)		6	6		20	20
Detector 1 Type		Cl+Ex	Cl+Ex		Cl+Ex	Cl+Ex
Detector 1 Channel						
Detector 1 Extend (s)		0.0	0.0		0.0	0.0
Detector 1 Queue (s)		0.0	0.0		0.0	0.0
Detector 1 Delay (s)		0.0	0.0		0.0	0.0
Detector 2 Position(ft)		94	94			
Detector 2 Size(ft)		6	6			
Detector 2 Type		Cl+Ex	Cl+Ex			
Detector 2 Channel						
Detector 2 Extend (s)		0.0	0.0			
Turn Type		NA	NA		Perm	Perm

Lanes, Volumes, Timings  
4: Shiloh Road & US 101 SB Off-Ramp

2028 Opening Year Alter. B Project Conditions

Timing Plan: Saturday Midday Peak

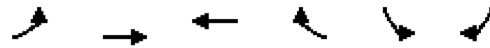

Lane Group	EBL	EBT	WBT	WBR	SBL	SBR
Protected Phases		2	6			
Permitted Phases					4	4
Detector Phase		2	6		4	4
Switch Phase						
Minimum Initial (s)		5.0	5.0		5.0	5.0
Minimum Split (s)		9.5	38.5		9.5	9.5
Total Split (s)		69.0	69.0		21.0	21.0
Total Split (%)		76.7%	76.7%		23.3%	23.3%
Maximum Green (s)		64.5	64.5		16.5	16.5
Yellow Time (s)		3.5	3.5		3.5	3.5
All-Red Time (s)		1.0	1.0		1.0	1.0
Lost Time Adjust (s)		0.0	0.0		0.0	0.0
Total Lost Time (s)		4.5	4.5		4.5	4.5
Lead/Lag						
Lead-Lag Optimize?						
Vehicle Extension (s)		3.0	3.0		3.0	3.0
Recall Mode		None	None		None	None
Walk Time (s)			7.0			
Flash Don't Walk (s)			27.0			
Pedestrian Calls (#/hr)			0			
Act Effct Green (s)		22.2	22.2		16.8	16.8
Actuated g/C Ratio		0.46	0.46		0.35	0.35
v/c Ratio		0.42	0.77		0.87	0.36
Control Delay (s/veh)		9.9	17.2		36.3	4.3
Queue Delay		0.0	0.0		0.0	0.0
Total Delay (s/veh)		9.9	17.2		36.3	4.3
LOS		A	B		D	A
Approach Delay (s/veh)		9.9	17.2		25.9	
Approach LOS		A	B		C	

Intersection Summary

Area Type:	Other
Cycle Length:	90
Actuated Cycle Length:	48.1
Natural Cycle:	65
Control Type:	Actuated-Uncoordinated
Maximum v/c Ratio:	0.87
Intersection Signal Delay (s/veh):	19.5
Intersection LOS:	B
Intersection Capacity Utilization:	132.4%
ICU Level of Service:	H
Analysis Period (min):	15

Splits and Phases: 4: Shiloh Road & US 101 SB Off-Ramp

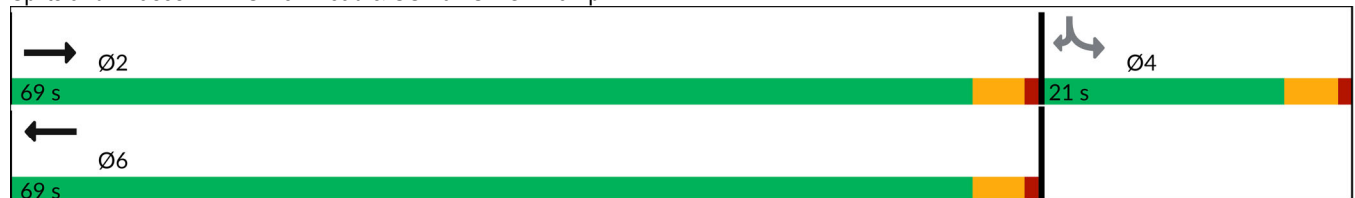

Lanes, Volumes, Timings  
5: Caletti Ave & Shiloh Road

2028 Opening Year Alter. B Project Conditions

Timing Plan: Saturday Midday Peak

	→	↘	↙	←	↖	↗
Lane Group	EBT	EBR	WBL	WBT	NBL	NBR
Lane Configurations	↑↑		↘	↑	↘	↗
Traffic Volume (vph)	642	23	92	709	18	89
Future Volume (vph)	642	23	92	709	18	89
Ideal Flow (vphp)	1900	1900	1900	1900	1900	1900
Storage Length (ft)		0	68		0	0
Storage Lanes		0	1		1	1
Taper Length (ft)			50		25	
Lane Util. Factor	0.95	0.95	1.00	1.00	1.00	1.00
Ped Bike Factor						
Frt	0.995					0.850
Flt Protected			0.950		0.950	
Satd. Flow (prot)	3522	0	1770	1863	1770	1583
Flt Permitted			0.950		0.950	
Satd. Flow (perm)	3522	0	1770	1863	1770	1583
Link Speed (mph)	40			40	30	
Link Distance (ft)	1081			184	459	
Travel Time (s)	18.4			3.1	10.4	
Confl. Peds. (#/hr)					1	
Confl. Bikes (#/hr)		1				
Peak Hour Factor	0.92	0.92	0.87	0.87	0.78	0.78
Adj. Flow (vph)	698	25	106	815	23	114
Shared Lane Traffic (%)						
Lane Group Flow (vph)	723	0	106	815	23	114
Enter Blocked Intersection	No	No	No	No	No	No
Lane Alignment	Left	Right	Left	Left	Left	Right
Median Width(ft)	12			12	12	
Link Offset(ft)	0			0	0	
Crosswalk Width(ft)	16			16	16	
Two way Left Turn Lane						
Headway Factor	1.00	1.00	1.00	1.00	1.00	1.00
Turning Speed (mph)		9	15		15	9
Sign Control	Free			Free	Stop	



















Intersection Summary

Area Type:	Other
Control Type:	Unsignalized
Intersection Capacity Utilization	47.3%
Analysis Period (min)	15
	ICU Level of Service A

Lanes, Volumes, Timings  
6: Conde Lane & Shiloh Road

2028 Opening Year Alter. B Project Conditions

Timing Plan: Saturday Midday Peak

													
Lane Group	EBL	EBT	EBR	WBL	WBT	WBR	NBL	NBT	NBR	SBL	SBT	SBR	
Lane Configurations													
Traffic Volume (vph)	33	432	1	10	481	232	1	0	7	224	0	32	
Future Volume (vph)	33	432	1	10	481	232	1	0	7	224	0	32	
Ideal Flow (vphpl)	1900	1900	1900	1900	1900	1900	1900	1900	1900	1900	1900	1900	
Storage Length (ft)	90		0	127		0	0		0	0		40	
Storage Lanes	1		0	1		0	0		0	0		1	
Taper Length (ft)	70			40			25			25			
Lane Util. Factor	1.00	0.95	0.95	1.00	0.95	0.95	1.00	1.00	1.00	1.00	1.00	1.00	
Ped Bike Factor					0.99								
Frt					0.951			0.884				0.850	
Flt Protected	0.950			0.950				0.993			0.950		
Satd. Flow (prot)	1770	3539	0	1770	3342	0	0	1635	0	0	1770	1583	
Flt Permitted	0.950			0.950				0.993			0.950		
Satd. Flow (perm)	1770	3539	0	1770	3342	0	0	1635	0	0	1770	1583	
Right Turn on Red			Yes			Yes			Yes			No	
Satd. Flow (RTOR)					82			102					
Link Speed (mph)		40			40			30				35	
Link Distance (ft)		815			1081			418				522	
Travel Time (s)		13.9			18.4			9.5				10.2	
Confl. Bikes (#/hr)						2							
Peak Hour Factor	0.96	0.96	0.96	0.91	0.91	0.91	0.58	0.58	0.58	0.78	0.78	0.78	
Adj. Flow (vph)	34	450	1	11	529	255	2	0	12	287	0	41	
Shared Lane Traffic (%)													
Lane Group Flow (vph)	34	451	0	11	784	0	0	14	0	0	287	41	
Enter Blocked Intersection	No	No	No	No	No	No	No	No	No	No	No	No	
Lane Alignment	Left	Left	Right	Left	Left	Right	Left	Left	Right	Left	Left	Right	
Median Width(ft)		12			12			0				0	
Link Offset(ft)		0			0			0				0	
Crosswalk Width(ft)		16			16			16				16	
Two way Left Turn Lane													
Headway Factor	1.00	1.00	1.00	1.00	1.00	1.00	1.00	1.00	1.00	1.00	1.00	1.00	
Turning Speed (mph)	15		9	15		9	15		9	15		9	
Number of Detectors	1	2		1	2		1	2		1	1	1	
Detector Template	Left	Thru		Left	Thru		Left	Thru		Left	Thru	Right	
Leading Detector (ft)	20	100		20	100		20	100		20	30	20	
Trailing Detector (ft)	0	0		0	0		0	0		0	0	0	
Detector 1 Position(ft)	0	0		0	0		0	0		0	0	0	
Detector 1 Size(ft)	20	6		20	6		20	6		20	30	20	
Detector 1 Type	Cl+Ex	Cl+Ex		Cl+Ex	Cl+Ex		Cl+Ex	Cl+Ex		Cl+Ex	Cl+Ex	Cl+Ex	
Detector 1 Channel													
Detector 1 Extend (s)	0.0	0.0		0.0	0.0		0.0	0.0		0.0	0.0	0.0	
Detector 1 Queue (s)	0.0	0.0		0.0	0.0		0.0	0.0		0.0	0.0	0.0	
Detector 1 Delay (s)	0.0	0.0		0.0	0.0		0.0	0.0		0.0	0.0	0.0	
Detector 2 Position(ft)		94			94			94					
Detector 2 Size(ft)		6			6			6					
Detector 2 Type		Cl+Ex			Cl+Ex			Cl+Ex					
Detector 2 Channel													
Detector 2 Extend (s)		0.0			0.0			0.0					
Turn Type	Prot	NA		Prot	NA		Split	NA		Split	NA	custom	

Lanes, Volumes, Timings  
6: Conde Lane & Shiloh Road

2028 Opening Year Alter. B Project Conditions

Timing Plan: Saturday Midday Peak

Lane Group	EBL	EBT	EBR	WBL	WBT	WBR	NBL	NBT	NBR	SBL	SBT	SBR
Protected Phases	5	2		1	6		7	7		4	4	
Permitted Phases												6
Detector Phase	5	2		1	6		7	7		4	4	6
Switch Phase												
Minimum Initial (s)	8.0	8.0		8.0	8.0		10.0	10.0		11.0	11.0	8.0
Minimum Split (s)	12.5	46.5		12.5	12.5		37.5	37.5		15.5	15.5	12.5
Total Split (s)	13.0	46.5		12.5	45.0		37.5	37.5		15.5	15.5	45.0
Total Split (%)	11.6%	41.5%		11.2%	40.2%		33.5%	33.5%		13.8%	13.8%	40.2%
Maximum Green (s)	8.5	42.0		8.0	40.5		33.0	33.0		11.0	11.0	40.5
Yellow Time (s)	3.5	3.5		3.5	3.5		3.5	3.5		3.5	3.5	3.5
All-Red Time (s)	1.0	1.0		1.0	1.0		1.0	1.0		1.0	1.0	1.0
Lost Time Adjust (s)	0.0	0.0		0.0	0.0		0.0	0.0		0.0	0.0	0.0
Total Lost Time (s)	4.5	4.5		4.5	4.5		4.5	4.5		4.5	4.5	4.5
Lead/Lag	Lead	Lag		Lead	Lag							Lag
Lead-Lag Optimize?	Yes	Yes		Yes	Yes							Yes
Vehicle Extension (s)	3.0	3.0		3.0	3.0		3.0	3.0		3.0	3.0	3.0
Recall Mode	None	None		None	None		None	None		None	None	None
Walk Time (s)		7.0					7.0	7.0				
Flash Don't Walk (s)		35.0					26.0	26.0				
Pedestrian Calls (#/hr)		0					0	0				
Act Effct Green (s)	9.0	20.0		9.0	17.8			11.2			12.3	17.8
Actuated g/C Ratio	0.20	0.44		0.20	0.39			0.25			0.27	0.39
v/c Ratio	0.10	0.29		0.03	0.58			0.03			0.60	0.07
Control Delay (s/veh)	23.9	9.8		24.5	13.0			0.1			28.8	12.0
Queue Delay	0.0	0.0		0.0	0.0			0.0			0.0	0.0
Total Delay (s/veh)	23.9	9.8		24.5	13.0			0.1			28.8	12.0
LOS	C	A		C	B			A			C	B
Approach Delay (s/veh)		10.8			13.2			0.1			26.7	
Approach LOS		B			B			A			C	

Intersection Summary

Area Type:	Other
Cycle Length:	112
Actuated Cycle Length:	45.7
Natural Cycle:	115
Control Type:	Actuated-Uncoordinated
Maximum v/c Ratio:	0.60
Intersection Signal Delay (s/veh):	15.1
Intersection LOS:	B
Intersection Capacity Utilization:	54.0%
ICU Level of Service:	A
Analysis Period (min):	15

Splits and Phases: 6: Conde Lane & Shiloh Road

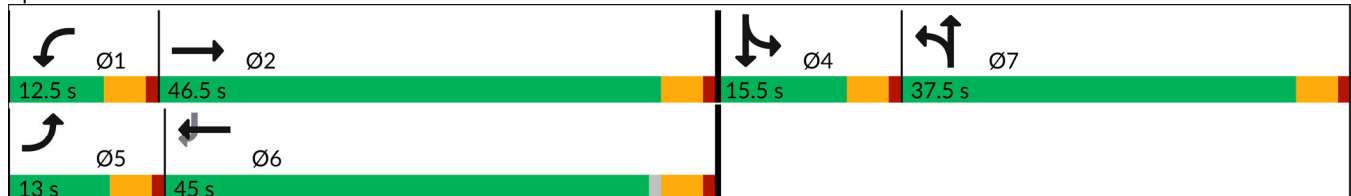

Lanes, Volumes, Timings  
7: Driveway 1/Gridley Drive & Shiloh Road

2028 Opening Year Alter. B Project Conditions

Timing Plan: Saturday Midday Peak

Lane Group	EBL	EBT	EBR	WBL	WBT	WBR	NBL	NBT	NBR	SBL	SBT	SBR
Lane Configurations												
Traffic Volume (vph)	23	436	103	0	450	0	113	0	0	0	0	20
Future Volume (vph)	23	436	103	0	450	0	113	0	0	0	0	20
Ideal Flow (vphp)	1900	1900	1900	1900	1900	1900	1900	1900	1900	1900	1900	1900
Storage Length (ft)	0		150	0		0	0		0	0		0
Storage Lanes	0		1	0		0	1		0	0		0
Taper Length (ft)	25			25			25			25		
Lane Util. Factor	1.00	1.00	1.00	1.00	1.00	1.00	1.00	1.00	1.00	1.00	1.00	1.00
Ped Bike Factor												
Frt			0.850								0.865	
Flt Protected		0.997					0.950					
Satd. Flow (prot)	0	1857	1583	0	1863	0	1770	1863	0	0	1611	0
Flt Permitted		0.997					0.950					
Satd. Flow (perm)	0	1857	1583	0	1863	0	1770	1863	0	0	1611	0
Link Speed (mph)		40			40			30			30	
Link Distance (ft)		608			2146			248			715	
Travel Time (s)		10.4			36.6			5.6			16.3	
Confl. Peds. (#/hr)	1											
Confl. Bikes (#/hr)			1			3						
Peak Hour Factor	0.93	0.93	0.93	0.88	0.88	0.88	1.00	1.00	1.00	0.56	0.56	0.56
Adj. Flow (vph)	25	469	111	0	511	0	113	0	0	0	0	36
Shared Lane Traffic (%)												
Lane Group Flow (vph)	0	494	111	0	511	0	113	0	0	0	36	0
Enter Blocked Intersection	No	No	No	No	No	No	No	No	No	No	No	No
Lane Alignment	Left	Left	Right	Left	Left	Right	Left	Left	Right	Left	Left	Right
Median Width(ft)		0			0			12			12	
Link Offset(ft)		0			0			0			0	
Crosswalk Width(ft)		16			16			16			16	
Two way Left Turn Lane												
Headway Factor	1.00	1.00	1.00	1.00	1.00	1.00	1.00	1.00	1.00	1.00	1.00	1.00
Turning Speed (mph)	15		9	15		9	15		9	15		9
Sign Control		Free			Free			Stop			Stop	





















Intersection Summary

Area Type:	Other
Control Type:	Unsignalized
Intersection Capacity Utilization	61.3%
Analysis Period (min)	15
	ICU Level of Service B

Lanes, Volumes, Timings  
8: Old Redwood Hwy & Driveway 2

2028 Opening Year Alter. B Project Conditions

Timing Plan: Saturday Midday Peak

												
Lane Group	EBL	EBT	EBR	WBL	WBT	WBR	NBL	NBT	NBR	SBL	SBT	SBR
Lane Configurations												
Traffic Volume (vph)	1	0	2	67	0	106	1	459	61	97	389	5
Future Volume (vph)	1	0	2	67	0	106	1	459	61	97	389	5
Ideal Flow (vphp)	1900	1900	1900	1900	1900	1900	1900	1900	1900	1900	1900	1900
Storage Length (ft)	0		0	0		0	0		100	50		0
Storage Lanes	0		0	1		0	0		1	1		0
Taper Length (ft)	25			25			25			25		
Lane Util. Factor	1.00	1.00	1.00	1.00	1.00	1.00	1.00	1.00	1.00	1.00	1.00	1.00
Ped Bike Factor												
Frt		0.916			0.850				0.850		0.998	
Flt Protected		0.982		0.950						0.950		
Satd. Flow (prot)	0	1676	0	1770	1583	0	0	1863	1583	1770	1859	0
Flt Permitted		0.982		0.950						0.950		
Satd. Flow (perm)	0	1676	0	1770	1583	0	0	1863	1583	1770	1859	0
Link Speed (mph)		30			30			45			45	
Link Distance (ft)		98			385			520			748	
Travel Time (s)		2.2			8.8			7.9			11.3	
Confl. Peds. (#/hr)							1		4	4		1
Confl. Bikes (#/hr)									3			9
Peak Hour Factor	0.38	0.38	0.38	1.00	1.00	1.00	0.94	0.94	0.94	0.93	0.93	0.93
Adj. Flow (vph)	3	0	5	67	0	106	1	488	65	104	418	5
Shared Lane Traffic (%)												
Lane Group Flow (vph)	0	8	0	67	106	0	0	489	65	104	423	0
Enter Blocked Intersection	No	No	No	No	No	No	No	No	No	No	No	No
Lane Alignment	Left	Left	Right	Left	Left	Right	Left	Left	Right	Left	Left	Right
Median Width(ft)		12			12			12			12	
Link Offset(ft)		0			0			0			0	
Crosswalk Width(ft)		16			16			16			16	
Two way Left Turn Lane												
Headway Factor	1.00	1.00	1.00	1.00	1.00	1.00	1.00	1.00	1.00	1.00	1.00	1.00
Turning Speed (mph)	15		9	15		9	15		9	15		9
Sign Control		Stop			Stop			Free			Free	

Intersection Summary

Area Type:	Other
Control Type:	Unsignalized
Intersection Capacity Utilization	64.3%
Analysis Period (min)	15
	ICU Level of Service C

Lanes, Volumes, Timings  
9: Driveway 3 & Shiloh Road

2028 Opening Year Alter. B Project Conditions

Timing Plan: Saturday Midday Peak

	→	↘	↙	←	↖	↗
Lane Group	EBT	EBR	WBL	WBT	NBL	NBR
Lane Configurations	↑	↗		↖	↘	↗
Traffic Volume (vph)	105	315	30	98	345	33
Future Volume (vph)	105	315	30	98	345	33
Ideal Flow (vphp)	1900	1900	1900	1900	1900	1900
Storage Length (ft)		200	0		0	0
Storage Lanes		1	0		1	1
Taper Length (ft)			25		25	
Lane Util. Factor	1.00	1.00	1.00	1.00	1.00	1.00
Ped Bike Factor						
Frt		0.850				0.850
Flt Protected				0.988	0.950	
Satd. Flow (prot)	1863	1583	0	1840	1770	1583
Flt Permitted				0.988	0.950	
Satd. Flow (perm)	1863	1583	0	1840	1770	1583
Link Speed (mph)	40			40	30	
Link Distance (ft)	2146			134	402	
Travel Time (s)	36.6			2.3	9.1	
Confl. Peds. (#/hr)		1				
Peak Hour Factor	0.88	0.88	0.80	0.80	1.00	1.00
Adj. Flow (vph)	119	358	38	123	345	33
Shared Lane Traffic (%)						
Lane Group Flow (vph)	119	358	0	161	345	33
Enter Blocked Intersection	No	No	No	No	No	No
Lane Alignment	Left	Right	Left	Left	Left	Right
Median Width(ft)	0			0	12	
Link Offset(ft)	0			0	0	
Crosswalk Width(ft)	16			16	16	
Two way Left Turn Lane						
Headway Factor	1.00	1.00	1.00	1.00	1.00	1.00
Turning Speed (mph)		9	15		15	9
Sign Control	Free			Free	Stop	
<b>Intersection Summary</b>						
Area Type:	Other					
Control Type:	Unsignalized					
Intersection Capacity Utilization	39.3%			ICU Level of Service A		
Analysis Period (min)	15					



Lanes, Volumes, Timings

2028 Opening Year Alter. B Project Conditions

10: US 101 NB Off Ramp/Lakewood Drive & Old Redwood Highway Timing Plan: Saturday Midday Peak



Lane Group	EBL	EBT	EBR	WBL	WBT	WBR	NBL	NBT	NBR	SBL	SBT	SBR
Lane Configurations												
Traffic Volume (vph)	287	374	0	0	569	276	320	303	142	244	0	700
Future Volume (vph)	287	374	0	0	569	276	320	303	142	244	0	700
Ideal Flow (vphpl)	1900	1900	1900	1900	1900	1900	1900	1900	1900	1900	1900	1900
Storage Length (ft)	155		0	0		0	270		150	120		0
Storage Lanes	1		0	0		0	1		1	1		1
Taper Length (ft)	50			25			165			75		
Lane Util. Factor	0.97	1.00	1.00	1.00	0.95	0.95	0.91	0.91	0.95	0.97	1.00	1.00
Ped Bike Factor	1.00				0.99			1.00		1.00		
Fr <sub>t</sub>					0.951			0.958				0.850
Fl <sub>t</sub> Protected	0.950						0.950	0.994		0.950		
Satd. Flow (prot)	3433	1863	0	0	3348	0	1610	3217	0	3433	0	1583
Fl <sub>t</sub> Permitted	0.950						0.950	0.994		0.950		
Satd. Flow (perm)	3430	1863	0	0	3348	0	1610	3217	0	3430	0	1583
Right Turn on Red			Yes			Yes			Yes			Yes
Satd. Flow (RTOR)					96			61				273
Link Speed (mph)		35			35			30				30
Link Distance (ft)		226			617			716				478
Travel Time (s)		4.4			12.0			16.3				10.9
Confl. Peds. (#/hr)	2		1	1		2			1	1		
Confl. Bikes (#/hr)			10			3						
Peak Hour Factor	0.95	0.95	0.95	0.89	0.89	0.89	0.98	0.98	0.98	0.88	0.88	0.88
Adj. Flow (vph)	302	394	0	0	639	310	327	309	145	277	0	795
Shared Lane Traffic (%)							20%					
Lane Group Flow (vph)	302	394	0	0	949	0	262	519	0	277	0	795
Enter Blocked Intersection	No	No	No	No	No	No	No	No	No	No	No	No
Lane Alignment	Left	Left	Right	Left	Left	Right	Left	Left	Right	Left	Left	Right
Median Width(ft)		24			24			24				24
Link Offset(ft)		0			0			0				0
Crosswalk Width(ft)		16			16			16				16
Two way Left Turn Lane												
Headway Factor	1.00	1.00	1.00	1.00	1.00	1.00	1.00	1.00	1.00	1.00	1.00	1.00
Turning Speed (mph)	15		9	15		9	15		9	15		9
Number of Detectors	1	2			2		1	2		1		1
Detector Template	Left	Thru			Thru		Left	Thru		Left		Right
Leading Detector (ft)	20	100			100		20	100		20		20
Trailing Detector (ft)	0	0			0		0	0		0		0
Detector 1 Position(ft)	0	0			0		0	0		0		0
Detector 1 Size(ft)	20	6			6		20	6		20		20
Detector 1 Type	Cl+Ex	Cl+Ex			Cl+Ex		Cl+Ex	Cl+Ex		Cl+Ex		Cl+Ex
Detector 1 Channel												
Detector 1 Extend (s)	0.0	0.0			0.0		0.0	0.0		0.0		0.0
Detector 1 Queue (s)	0.0	0.0			0.0		0.0	0.0		0.0		0.0
Detector 1 Delay (s)	0.0	0.0			0.0		0.0	0.0		0.0		0.0
Detector 2 Position(ft)		94			94			94				
Detector 2 Size(ft)		6			6			6				
Detector 2 Type		Cl+Ex			Cl+Ex			Cl+Ex				
Detector 2 Channel												
Detector 2 Extend (s)		0.0			0.0			0.0				

Lanes, Volumes, Timings

2028 Opening Year Alter. B Project Conditions

10: US 101 NB Off Ramp/Lakewood Drive & Old Redwood Highway Timing Plan: Saturday Midday Peak



Lane Group	EBL	EBT	EBR	WBL	WBT	WBR	NBL	NBT	NBR	SBL	SBT	SBR
Turn Type	Prot	NA			NA		Split	NA		Prot		pm+ov
Protected Phases	5	2			6		8	8		7		5
Permitted Phases												5 8
Detector Phase	5	2			6		8	8		7		5
Switch Phase												
Minimum Initial (s)	7.0	10.0			10.0		10.0	10.0		7.0		7.0
Minimum Split (s)	11.5	32.1			32.1		33.7	33.7		11.5		11.5
Total Split (s)	12.0	45.3			33.3		33.7	33.7		11.5		12.0
Total Split (%)	13.3%	50.1%			36.8%		37.2%	37.2%		12.7%		13.3%
Maximum Green (s)	7.5	40.8			28.8		29.2	29.2		7.0		7.5
Yellow Time (s)	3.5	3.5			3.5		3.5	3.5		3.5		3.5
All-Red Time (s)	1.0	1.0			1.0		1.0	1.0		1.0		1.0
Lost Time Adjust (s)	0.0	0.0			0.0		0.0	0.0		0.0		0.0
Total Lost Time (s)	4.5	4.5			4.5		4.5	4.5		4.5		4.5
Lead/Lag	Lead				Lag		Lag	Lag		Lead		Lead
Lead-Lag Optimize?	Yes				Yes		Yes	Yes		Yes		Yes
Vehicle Extension (s)	3.0	3.0			3.0		3.0	3.0		3.0		3.0
Recall Mode	None	Max			Max		None	None		None		None
Walk Time (s)		7.0			7.0		7.0	7.0				
Flash Don't Walk (s)		20.0			17.0		22.0	22.0				
Pedestrian Calls (#/hr)		0			0		0	0				
Act Effct Green (s)	7.5	41.0			29.0		20.3	20.3		7.0		32.4
Actuated g/C Ratio	0.09	0.50			0.35		0.25	0.25		0.09		0.40
v/c Ratio	0.96	0.42			0.76		0.66	0.61		0.94		1.01
Control Delay (s/veh)	81.7	16.0			27.0		35.6	26.8		80.3		50.9
Queue Delay	0.0	0.0			0.0		0.0	0.0		0.0		0.0
Total Delay (s/veh)	81.7	16.0			27.0		35.6	26.8		80.3		50.9
LOS	F	B			C		D	C		F		D
Approach Delay (s/veh)		44.5			27.0			29.8				58.5
Approach LOS		D			C			C				E

Intersection Summary

Area Type: Other  
 Cycle Length: 90.5  
 Actuated Cycle Length: 82  
 Natural Cycle: 90  
 Control Type: Actuated-Uncoordinated  
 Maximum v/c Ratio: 1.01  
 Intersection Signal Delay (s/veh): 40.8  
 Intersection LOS: D  
 Intersection Capacity Utilization 94.4%  
 ICU Level of Service F  
 Analysis Period (min) 15

Splits and Phases: 10: US 101 NB Off Ramp/Lakewood Drive & Old Redwood Highway

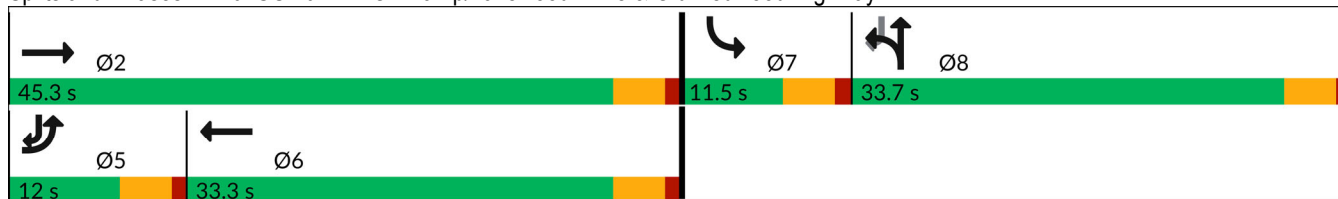

Lanes, Volumes, Timings  
 11: Old Redwood Highway & US 101 NB On Ramp

2028 Opening Year Alter. B Project Conditions

Timing Plan: Saturday Midday Peak

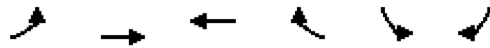

Lane Group	EBL	EBT	WBT	WBR	SBL	SBR
Lane Configurations	↶	↷↷	↶↷			
Traffic Volume (vph)	87	666	1310	215	0	0
Future Volume (vph)	87	666	1310	215	0	0
Ideal Flow (vphp)	1900	1900	1900	1900	1900	1900
Storage Length (ft)	245			0	0	0
Storage Lanes	1			0	0	0
Taper Length (ft)	50				25	
Lane Util. Factor	1.00	0.95	0.95	0.95	1.00	1.00
Ped Bike Factor						
Frt			0.979			
Flt Protected	0.950					
Satd. Flow (prot)	1770	3539	3465	0	0	0
Flt Permitted	0.950					
Satd. Flow (perm)	1770	3539	3465	0	0	0
Link Speed (mph)		35	35		30	
Link Distance (ft)		531	226		299	
Travel Time (s)		10.3	4.4		6.8	
Confl. Peds. (#/hr)	8			8		
Confl. Bikes (#/hr)				4		
Peak Hour Factor	0.96	0.96	0.92	0.92	0.25	0.25
Adj. Flow (vph)	91	694	1424	234	0	0
Shared Lane Traffic (%)						
Lane Group Flow (vph)	91	694	1658	0	0	0
Enter Blocked Intersection	No	No	No	No	No	No
Lane Alignment	Left	Left	Left	Right	Left	Right
Median Width(ft)		12	12		0	
Link Offset(ft)		0	0		0	
Crosswalk Width(ft)		16	16		16	
Two way Left Turn Lane						
Headway Factor	1.00	1.00	1.00	1.00	1.00	1.00
Turning Speed (mph)	15			9	15	9
Sign Control		Free	Free		Free	

Intersection Summary

Area Type:	Other
Control Type:	Unsignalized
Intersection Capacity Utilization	72.9%
Analysis Period (min)	15
	ICU Level of Service C

Lanes, Volumes, Timings

2028 Opening Year Alter. B Project Conditions

12: US 101 SB On Ramp/US 101 SB Off Ramp & Old Redwood Highway Timing Plan: Saturday Midday Peak



Lane Group	EBL	EBT	EBR	WBL	WBT	WBR	NBL	NBT	NBR	SBL	SBT	SBR
Lane Configurations		↑↑	↗	↘	↑↑					↘	↕	
Traffic Volume (vph)	0	550	419	487	818	0	0	0	0	212	1	87
Future Volume (vph)	0	550	419	487	818	0	0	0	0	212	1	87
Ideal Flow (vphpl)	1900	1900	1900	1900	1900	1900	1900	1900	1900	1900	1900	1900
Storage Length (ft)	0		0	250		0	0		0	420		0
Storage Lanes	0		1	0		0	0		0	1		0
Taper Length (ft)	25			165			25			75		
Lane Util. Factor	1.00	0.95	1.00	1.00	0.95	1.00	1.00	1.00	1.00	0.95	0.95	1.00
Ped Bike Factor			0.98	1.00								
Frt			0.850								0.910	
Flt Protected				0.950						0.950	0.981	
Satd. Flow (prot)	0	3539	1583	1770	3539	0	0	0	0	1681	1580	0
Flt Permitted				0.950						0.950	0.981	
Satd. Flow (perm)	0	3539	1553	1768	3539	0	0	0	0	1681	1580	0
Right Turn on Red			Yes			Yes			Yes			Yes
Satd. Flow (RTOR)			432								91	
Link Speed (mph)		35			35			30			30	
Link Distance (ft)		423			531			621			831	
Travel Time (s)		8.2			10.3			14.1			18.9	
Confl. Peds. (#/hr)	11		2	2		11						
Confl. Bikes (#/hr)			10			2						
Peak Hour Factor	0.97	0.97	0.97	0.96	0.96	0.96	0.25	0.25	0.25	0.72	0.72	0.72
Adj. Flow (vph)	0	567	432	507	852	0	0	0	0	294	1	121
Shared Lane Traffic (%)										27%		
Lane Group Flow (vph)	0	567	432	507	852	0	0	0	0	215	201	0
Enter Blocked Intersection	No	No	No	No	No	No	No	No	No	No	No	No
Lane Alignment	Left	Left	Right	Left	Left	Right	Left	Left	Right	Left	Left	Right
Median Width(ft)		24			24			12			12	
Link Offset(ft)		0			0			0			0	
Crosswalk Width(ft)		16			16			16			16	
Two way Left Turn Lane												
Headway Factor	1.00	1.00	1.00	1.00	1.00	1.00	1.00	1.00	1.00	1.00	1.00	1.00
Turning Speed (mph)	15		9	15		9	15		9	15		9
Number of Detectors		2	1	1	2					1	2	
Detector Template		Thru	Right	Left	Thru					Left	Thru	
Leading Detector (ft)		100	20	20	100					20	100	
Trailing Detector (ft)		0	0	0	0					0	0	
Detector 1 Position(ft)		0	0	0	0					0	0	
Detector 1 Size(ft)		6	20	20	6					20	6	
Detector 1 Type		Cl+Ex	Cl+Ex	Cl+Ex	Cl+Ex					Cl+Ex	Cl+Ex	
Detector 1 Channel												
Detector 1 Extend (s)		0.0	0.0	0.0	0.0					0.0	0.0	
Detector 1 Queue (s)		0.0	0.0	0.0	0.0					0.0	0.0	
Detector 1 Delay (s)		0.0	0.0	0.0	0.0					0.0	0.0	
Detector 2 Position(ft)		94			94						94	
Detector 2 Size(ft)		6			6						6	
Detector 2 Type		Cl+Ex			Cl+Ex						Cl+Ex	
Detector 2 Channel												
Detector 2 Extend (s)		0.0			0.0						0.0	

Lanes, Volumes, Timings

2028 Opening Year Alter. B Project Conditions

12: US 101 SB On Ramp/US 101 SB Off Ramp & Old Redwood Highway Timing Plan: Saturday Midday Peak



Lane Group	EBL	EBT	EBR	WBL	WBT	WBR	NBL	NBT	NBR	SBL	SBT	SBR
Turn Type		NA	Perm	Prot	NA					Perm	NA	
Protected Phases		6		5	2						8	
Permitted Phases			6							8		
Detector Phase		6	6	5	2					8	8	
Switch Phase												
Minimum Initial (s)		10.0	10.0	7.0	10.0					10.0	10.0	
Minimum Split (s)		32.1	32.1	11.5	38.1					14.7	14.7	
Total Split (s)		32.3	32.3	23.0	55.3					14.7	14.7	
Total Split (%)		46.1%	46.1%	32.9%	79.0%					21.0%	21.0%	
Maximum Green (s)		27.8	27.8	18.5	50.8					10.2	10.2	
Yellow Time (s)		3.5	3.5	3.5	3.5					3.5	3.5	
All-Red Time (s)		1.0	1.0	1.0	1.0					1.0	1.0	
Lost Time Adjust (s)		0.0	0.0	0.0	0.0					0.0	0.0	
Total Lost Time (s)		4.5	4.5	4.5	4.5					4.5	4.5	
Lead/Lag		Lag	Lag	Lead								
Lead-Lag Optimize?		Yes	Yes	Yes								
Vehicle Extension (s)		3.0	3.0	3.0	3.0					3.0	3.0	
Recall Mode		Max	Max	None	Max					None	None	
Walk Time (s)		7.0	7.0		7.0							
Flash Don't Walk (s)		20.0	20.0		25.0							
Pedestrian Calls (#/hr)		0	0		0							
Act Effct Green (s)		27.8	27.8	18.5	50.8					10.2	10.2	
Actuated g/C Ratio		0.40	0.40	0.26	0.73					0.15	0.15	
v/c Ratio		0.40	0.49	1.09	0.33					0.88	0.65	
Control Delay (s/veh)		16.2	3.8	95.1	3.9					66.6	27.4	
Queue Delay		0.0	0.0	0.0	0.0					0.0	0.0	
Total Delay (s/veh)		16.2	3.8	95.1	3.9					66.6	27.4	
LOS		B	A	F	A					E	C	
Approach Delay (s/veh)		10.9			37.9						47.7	
Approach LOS		B			D						D	

Intersection Summary

Area Type: Other  
 Cycle Length: 70  
 Actuated Cycle Length: 70  
 Natural Cycle: 80  
 Control Type: Actuated-Uncoordinated  
 Maximum v/c Ratio: 1.09  
 Intersection Signal Delay (s/veh): 29.6  
 Intersection LOS: C  
 Intersection Capacity Utilization 72.9%  
 ICU Level of Service C  
 Analysis Period (min) 15



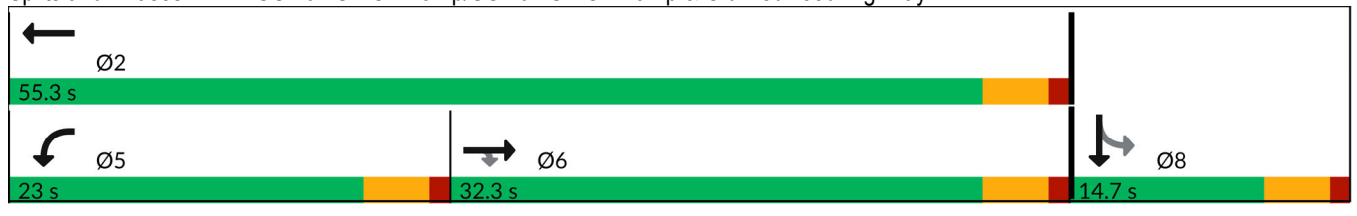



















Splits and Phases: 12: US 101 SB On Ramp/US 101 SB Off Ramp & Old Redwood Highway



Appendix I – Opening Year 2028 plus Alternative C Project  
Conditions Intersection Level of Service Worksheets





















HCM 6th Signalized Intersection Summary  
1: Old Redwood Hwy & Shiloh Road

2028 Opening Year Alter. C Project Conditions  
Timing Plan: A.M. PEAK

												
Movement	EBL	EBT	EBR	WBL	WBT	WBR	NBL	NBT	NBR	SBL	SBT	SBR
Lane Configurations												
Traffic Volume (veh/h)	137	176	109	25	98	18	102	143	39	22	265	208
Future Volume (veh/h)	137	176	109	25	98	18	102	143	39	22	265	208
Initial Q (Qb), veh	0	0	0	0	0	0	0	0	0	0	0	0
Ped-Bike Adj(A_pbT)	1.00		1.00	1.00		1.00	1.00		1.00	1.00		0.98
Parking Bus, Adj	1.00	1.00	1.00	1.00	1.00	1.00	1.00	1.00	1.00	1.00	1.00	1.00
Work Zone On Approach		No			No			No			No	
Adj Sat Flow, veh/h/ln	1870	1870	1870	1870	1870	1870	1870	1870	1870	1870	1870	1870
Adj Flow Rate, veh/h	169	217	135	28	110	20	110	154	42	26	312	245
Peak Hour Factor	0.81	0.81	0.81	0.89	0.89	0.89	0.93	0.93	0.93	0.85	0.85	0.85
Percent Heavy Veh, %	2	2	2	2	2	2	2	2	2	2	2	2
Cap, veh/h	337	354	300	43	167	179	182	459	389	183	460	381
Arrive On Green	0.19	0.19	0.19	0.11	0.11	0.11	0.10	0.25	0.25	0.10	0.25	0.25
Sat Flow, veh/h	1781	1870	1585	376	1476	1585	1781	1870	1585	1781	1870	1551
Grp Volume(v), veh/h	169	217	135	138	0	20	110	154	42	26	312	245
Grp Sat Flow(s),veh/h/ln	1781	1870	1585	1852	0	1585	1781	1870	1585	1781	1870	1551
Q Serve(g_s), s	4.1	5.2	3.7	3.5	0.0	0.6	2.9	3.3	1.0	0.6	7.3	6.9
Cycle Q Clear(g_c), s	4.1	5.2	3.7	3.5	0.0	0.6	2.9	3.3	1.0	0.6	7.3	6.9
Prop In Lane	1.00		1.00	0.20		1.00	1.00		1.00	1.00		1.00
Lane Grp Cap(c), veh/h	337	354	300	210	0	179	182	459	389	183	460	381
V/C Ratio(X)	0.50	0.61	0.45	0.66	0.00	0.11	0.60	0.34	0.11	0.14	0.68	0.64
Avail Cap(c_a), veh/h	1116	1172	993	1446	0	1238	531	1672	1417	220	1345	1116
HCM Platoon Ratio	1.00	1.00	1.00	1.00	1.00	1.00	1.00	1.00	1.00	1.00	1.00	1.00
Upstream Filter(I)	1.00	1.00	1.00	1.00	0.00	1.00	1.00	1.00	1.00	1.00	1.00	1.00
Uniform Delay (d), s/veh	17.7	18.1	17.5	20.7	0.0	19.4	20.9	15.1	14.2	19.9	16.6	16.4
Incr Delay (d2), s/veh	1.2	1.7	1.1	3.5	0.0	0.3	3.2	0.4	0.1	0.4	1.8	1.8
Initial Q Delay(d3),s/veh	0.0	0.0	0.0	0.0	0.0	0.0	0.0	0.0	0.0	0.0	0.0	0.0
%ile BackOfQ(50%),veh/ln	1.5	2.0	1.2	1.5	0.0	0.2	1.2	1.2	0.3	0.2	2.8	2.2
Unsig. Movement Delay, s/veh												
LnGrp Delay(d),s/veh	18.8	19.8	18.5	24.2	0.0	19.7	24.1	15.5	14.4	20.2	18.4	18.2
LnGrp LOS	B	B	B	C	A	B	C	B	B	C	B	B
Approach Vol, veh/h		521			158			306			583	
Approach Delay, s/veh		19.1			23.6			18.5			18.4	
Approach LOS		B			C			B			B	
Timer - Assigned Phs		2	3	4		6	7	8				
Phs Duration (G+Y+Rc), s		13.7	8.5	16.5		10.0	8.5	16.4				
Change Period (Y+Rc), s		4.5	3.5	4.5		4.5	3.5	4.5				
Max Green Setting (Gmax), s		30.5	14.5	35.0		38.0	6.0	43.5				
Max Q Clear Time (g_c+I1), s		7.2	4.9	9.3		5.5	2.6	5.3				
Green Ext Time (p_c), s		2.1	0.2	2.6		0.8	0.0	0.9				
<b>Intersection Summary</b>												
HCM 6th Ctrl Delay				19.2								
HCM 6th LOS				B								

HCM 6th Signalized Intersection Summary  
2: Shiloh Road & Hembree Ln

2028 Opening Year Alter. C Project Conditions  
Timing Plan: A.M. PEAK

												
Movement	EBL	EBT	EBR	WBL	WBT	WBR	NBL	NBT	NBR	SBL	SBT	SBR
Lane Configurations												
Traffic Volume (veh/h)	347	371	38	19	366	82	39	7	11	81	9	413
Future Volume (veh/h)	347	371	38	19	366	82	39	7	11	81	9	413
Initial Q (Qb), veh	0	0	0	0	0	0	0	0	0	0	0	0
Ped-Bike Adj(A_pbT)	1.00		1.00	1.00		1.00	1.00		1.00	1.00		1.00
Parking Bus, Adj	1.00	1.00	1.00	1.00	1.00	1.00	1.00	1.00	1.00	1.00	1.00	1.00
Work Zone On Approach		No			No			No			No	
Adj Sat Flow, veh/h/ln	1870	1870	1870	1870	1870	1870	1870	1870	1870	1870	1870	1870
Adj Flow Rate, veh/h	394	422	38	19	377	85	39	7	11	86	9	439
Peak Hour Factor	0.88	0.88	1.00	1.00	0.97	0.97	1.00	1.00	1.00	0.94	1.00	0.94
Percent Heavy Veh, %	2	2	2	2	2	2	2	2	2	2	2	2
Cap, veh/h	587	619	56	42	634	142	100	37	58	345	36	607
Arrive On Green	0.17	0.37	0.37	0.02	0.22	0.22	0.06	0.06	0.06	0.21	0.21	0.21
Sat Flow, veh/h	3456	1691	152	1781	2887	644	1781	655	1030	1620	170	1585
Grp Volume(v), veh/h	394	0	460	19	230	232	39	0	18	95	0	439
Grp Sat Flow(s),veh/h/ln	1728	0	1843	1781	1777	1754	1781	0	1685	1789	0	1585
Q Serve(g_s), s	5.0	0.0	9.9	0.5	5.5	5.6	1.0	0.0	0.5	2.1	0.0	10.0
Cycle Q Clear(g_c), s	5.0	0.0	9.9	0.5	5.5	5.6	1.0	0.0	0.5	2.1	0.0	10.0
Prop In Lane	1.00		0.08	1.00		0.37	1.00		0.61	0.91		1.00
Lane Grp Cap(c), veh/h	587	0	675	42	390	385	100	0	94	382	0	607
V/C Ratio(X)	0.67	0.00	0.68	0.46	0.59	0.60	0.39	0.00	0.19	0.25	0.00	0.72
Avail Cap(c_a), veh/h	1253	0	2083	209	1573	1553	209	0	198	382	0	607
HCM Platoon Ratio	1.00	1.00	1.00	1.00	1.00	1.00	1.00	1.00	1.00	1.00	1.00	1.00
Upstream Filter(I)	1.00	0.00	1.00	1.00	1.00	1.00	1.00	0.00	1.00	1.00	0.00	1.00
Uniform Delay (d), s/veh	18.2	0.0	12.5	22.6	16.4	16.4	21.4	0.0	21.1	15.3	0.0	12.3
Incr Delay (d2), s/veh	1.3	0.0	1.2	7.6	1.4	1.5	2.5	0.0	1.0	0.3	0.0	4.2
Initial Q Delay(d3),s/veh	0.0	0.0	0.0	0.0	0.0	0.0	0.0	0.0	0.0	0.0	0.0	0.0
%ile BackOfQ(50%),veh/ln	1.8	0.0	3.3	0.3	2.0	2.0	0.4	0.0	0.2	0.8	0.0	3.8
Unsig. Movement Delay, s/veh												
LnGrp Delay(d),s/veh	19.6	0.0	13.8	30.2	17.8	17.9	23.9	0.0	22.1	15.7	0.0	16.6
LnGrp LOS	B	A	B	C	B	B	C	A	C	B	A	B
Approach Vol, veh/h		854			481			57				534
Approach Delay, s/veh		16.4			18.4			23.3				16.4
Approach LOS		B			B			C				B
Timer - Assigned Phs	1	2		4	5	6		8				
Phs Duration (G+Y+Rc), s	5.1	21.2		14.0	12.0	14.3		6.6				
Change Period (Y+Rc), s	4.0	4.0		4.0	4.0	4.0		4.0				
Max Green Setting (Gmax), s	5.5	53.0		10.0	17.0	41.5		5.5				
Max Q Clear Time (g_c+I1), s	2.5	11.9		12.0	7.0	7.6		3.0				
Green Ext Time (p_c), s	0.0	3.0		0.0	1.0	2.7		0.0				
<b>Intersection Summary</b>												
HCM 6th Ctrl Delay				17.1								
HCM 6th LOS				B								



HCM 6th Signalized Intersection Summary  
 3: US 101 NB Off-Ramp & Shiloh Road

2028 Opening Year Alter. C Project Conditions  
 Timing Plan: A.M. PEAK



Movement	EBT	EBR	WBL	WBT	NBL	NBR
Lane Configurations	↑↑			↑	↘	↗
Traffic Volume (veh/h)	304	0	0	645	492	468
Future Volume (veh/h)	304	0	0	645	492	468
Initial Q (Qb), veh	0	0	0	0	0	0
Ped-Bike Adj(A_pbT)		1.00	1.00		1.00	1.00
Parking Bus, Adj	1.00	1.00	1.00	1.00	1.00	1.00
Work Zone On Approach	No			No	No	
Adj Sat Flow, veh/h/ln	1870	0	0	1870	1870	1870
Adj Flow Rate, veh/h	334	0	0	717	647	616
Peak Hour Factor	0.91	0.91	0.90	0.90	0.76	0.76
Percent Heavy Veh, %	2	0	0	2	2	2
Cap, veh/h	1562	0	0	822	757	1186
Arrive On Green	0.44	0.00	0.00	0.44	0.43	0.43
Sat Flow, veh/h	3741	0	0	1870	1781	2790
Grp Volume(v), veh/h	334	0	0	717	647	616
Grp Sat Flow(s),veh/h/ln	1777	0	0	1870	1781	1395
Q Serve(g_s), s	3.4	0.0	0.0	20.6	19.4	9.6
Cycle Q Clear(g_c), s	3.4	0.0	0.0	20.6	19.4	9.6
Prop In Lane		0.00	0.00		1.00	1.00
Lane Grp Cap(c), veh/h	1562	0	0	822	757	1186
V/C Ratio(X)	0.21	0.00	0.00	0.87	0.85	0.52
Avail Cap(c_a), veh/h	1984	0	0	1044	934	1463
HCM Platoon Ratio	1.00	1.00	1.00	1.00	1.00	1.00
Upstream Filter(I)	1.00	0.00	0.00	1.00	1.00	1.00
Uniform Delay (d), s/veh	10.2	0.0	0.0	15.1	15.3	12.5
Incr Delay (d2), s/veh	0.1	0.0	0.0	6.8	6.6	0.4
Initial Q Delay(d3),s/veh	0.0	0.0	0.0	0.0	0.0	0.0
%ile BackOfQ(50%),veh/ln	1.1	0.0	0.0	8.4	8.0	2.6
Unsig. Movement Delay, s/veh						
LnGrp Delay(d),s/veh	10.3	0.0	0.0	21.8	21.9	12.9
LnGrp LOS	B	A	A	C	C	B
Approach Vol, veh/h	334			717	1263	
Approach Delay, s/veh	10.3			21.8	17.5	
Approach LOS	B			C	B	
Timer - Assigned Phs		2			6	8
Phs Duration (G+Y+Rc), s		30.0			30.0	29.1
Change Period (Y+Rc), s		4.0			4.0	4.0
Max Green Setting (Gmax), s		33.0			33.0	31.0
Max Q Clear Time (g_c+I1), s		5.4			22.6	21.4
Green Ext Time (p_c), s		2.1			3.4	3.7
<b>Intersection Summary</b>						
HCM 6th Ctrl Delay			17.8			
HCM 6th LOS			B			

HCM Signalized Intersection Capacity Analysis 2028 Opening Year Alter. C Project Conditions  
 4: Shiloh Road & US 101 SB Off-Ramp

Timing Plan: A.M. PEAK



Movement	EBL	EBT	WBT	WBR	SBL	SBR
Lane Configurations		↑	↑		↘	↗
Traffic Volume (vph)	0	272	679	0	115	174
Future Volume (vph)	0	272	679	0	115	174
Ideal Flow (vphpl)	1900	1900	1900	1900	1900	1900
Total Lost time (s)		4.0	4.0		4.0	4.0
Lane Util. Factor		1.00	1.00		1.00	1.00
Frt		1.00	1.00		1.00	0.85
Flt Protected		1.00	1.00		0.95	1.00
Satd. Flow (prot)		1863	1863		1770	1583
Flt Permitted		1.00	1.00		0.95	1.00
Satd. Flow (perm)		1863	1863		1770	1583
Peak-hour factor, PHF	0.93	0.93	0.91	0.91	0.92	0.92
Adj. Flow (vph)	0	292	746	0	125	189
RTOR Reduction (vph)	0	0	0	0	0	147
Lane Group Flow (vph)	0	292	746	0	125	42
Turn Type		NA	NA		Perm	Perm
Protected Phases		2	6			
Permitted Phases					4	4
Actuated Green, G (s)		22.4	22.4		8.6	8.6
Effective Green, g (s)		22.4	22.4		8.6	8.6
Actuated g/C Ratio		0.57	0.57		0.22	0.22
Clearance Time (s)		4.0	4.0		4.0	4.0
Vehicle Extension (s)		3.0	3.0		3.0	3.0
Lane Grp Cap (vph)		1070	1070		390	349
v/s Ratio Prot		0.16	c0.40			
v/s Ratio Perm					c0.07	0.03
v/c Ratio		0.27	0.70		0.32	0.12
Uniform Delay, d1		4.2	5.9		12.7	12.2
Progression Factor		1.00	1.00		1.00	1.00
Incremental Delay, d2		0.1	2.0		0.5	0.2
Delay (s)		4.3	7.9		13.2	12.3
Level of Service		A	A		B	B
Approach Delay (s)		4.3	7.9		12.7	
Approach LOS		A	A		B	

Intersection Summary			
HCM 2000 Control Delay	8.2	HCM 2000 Level of Service	A
HCM 2000 Volume to Capacity ratio	0.59		
Actuated Cycle Length (s)	39.0	Sum of lost time (s)	8.0
Intersection Capacity Utilization	64.9%	ICU Level of Service	C
Analysis Period (min)	15		

c Critical Lane Group

Intersection						
Int Delay, s/veh	2.9					
Movement	EBT	EBR	WBL	WBT	NBL	NBR
Lane Configurations	↑↑		↘	↑	↘	↘
Traffic Vol, veh/h	595	25	202	626	8	138
Future Vol, veh/h	595	25	202	626	8	138
Conflicting Peds, #/hr	0	0	0	0	0	0
Sign Control	Free	Free	Free	Free	Stop	Stop
RT Channelized	-	None	-	None	-	None
Storage Length	-	-	68	-	0	0
Veh in Median Storage, #	0	-	-	0	0	-
Grade, %	0	-	-	0	0	-
Peak Hour Factor	96	96	87	87	84	84
Heavy Vehicles, %	2	2	2	2	2	2
Mvmt Flow	620	26	232	720	10	164

Major/Minor	Major1	Major2	Minor1		
Conflicting Flow All	0	0	646	0	1817 323
Stage 1	-	-	-	-	633 -
Stage 2	-	-	-	-	1184 -
Critical Hdwy	-	-	4.13	-	6.63 6.93
Critical Hdwy Stg 1	-	-	-	-	5.83 -
Critical Hdwy Stg 2	-	-	-	-	5.43 -
Follow-up Hdwy	-	-	2.219	-	3.519 3.319
Pot Cap-1 Maneuver	-	-	937	-	77 673
Stage 1	-	-	-	-	492 -
Stage 2	-	-	-	-	289 -
Platoon blocked, %	-	-	-	-	-
Mov Cap-1 Maneuver	-	-	937	-	58 673
Mov Cap-2 Maneuver	-	-	-	-	58 -
Stage 1	-	-	-	-	492 -
Stage 2	-	-	-	-	217 -

Approach	EB	WB	NB
HCM Control Delay, s	0	2.5	15.8
HCM LOS			C

Minor Lane/Major Mvmt	NBLn1	NBLn2	EBT	EBR	WBL	WBT
Capacity (veh/h)	58	673	-	-	937	-
HCM Lane V/C Ratio	0.164	0.244	-	-	0.248	-
HCM Control Delay (s)	78.9	12.1	-	-	10.1	-
HCM Lane LOS	F	B	-	-	B	-
HCM 95th %tile Q(veh)	0.5	1	-	-	1	-

HCM Signalized Intersection Capacity Analysis 2028 Opening Year Alter. C Project Conditions  
 6: Conde Lane & Shiloh Road

Timing Plan: A.M. PEAK



Movement	EBL	EBT	EBR	WBL	WBT	WBR	NBL	NBT	NBR	SBL	SBT	SBR
Lane Configurations												
Traffic Volume (vph)	28	373	6	10	403	232	5	0	14	233	1	40
Future Volume (vph)	28	373	6	10	403	232	5	0	14	233	1	40
Ideal Flow (vphpl)	1900	1900	1900	1900	1900	1900	1900	1900	1900	1900	1900	1900
Total Lost time (s)	4.0	4.0		4.0	4.0			4.0			4.0	4.0
Lane Util. Factor	1.00	0.95		1.00	0.95			1.00			1.00	1.00
Frt	1.00	1.00		1.00	0.95			0.90			1.00	0.85
Flt Protected	0.95	1.00		0.95	1.00			0.99			0.95	1.00
Satd. Flow (prot)	1770	3531		1770	3345			1656			1774	1583
Flt Permitted	0.95	1.00		0.95	1.00			0.99			0.95	1.00
Satd. Flow (perm)	1770	3531		1770	3345			1656			1774	1583
Peak-hour factor, PHF	0.95	0.95	0.95	0.85	0.85	0.85	0.57	0.57	0.57	0.86	0.86	0.86
Adj. Flow (vph)	29	393	6	12	474	273	9	0	25	271	1	47
RTOR Reduction (vph)	0	1	0	0	77	0	0	32	0	0	0	0
Lane Group Flow (vph)	29	398	0	12	670	0	0	2	0	0	272	47
Turn Type	Prot	NA		Prot	NA		Split	NA		Split	NA	custom
Protected Phases	5	2		1	6		7	7		4	4	
Permitted Phases												6
Actuated Green, G (s)	2.2	19.5		1.0	18.3			2.7			12.8	18.3
Effective Green, g (s)	2.2	19.5		1.0	18.3			2.7			12.8	18.3
Actuated g/C Ratio	0.04	0.38		0.02	0.35			0.05			0.25	0.35
Clearance Time (s)	4.0	4.0		4.0	4.0			4.0			4.0	4.0
Vehicle Extension (s)	3.0	3.0		3.0	3.0			3.0			3.0	3.0
Lane Grp Cap (vph)	74	1324		34	1177			85			436	557
v/s Ratio Prot	c0.02	0.11		0.01	c0.20			c0.00			c0.15	
v/s Ratio Perm												0.03
v/c Ratio	0.39	0.30		0.35	0.57			0.02			0.62	0.08
Uniform Delay, d1	24.2	11.4		25.2	13.7			23.4			17.5	11.3
Progression Factor	1.00	1.00		1.00	1.00			1.00			1.00	1.00
Incremental Delay, d2	3.4	0.1		6.2	0.6			0.1			2.8	0.1
Delay (s)	27.7	11.6		31.4	14.3			23.5			20.2	11.3
Level of Service	C	B		C	B			C			C	B
Approach Delay (s)		12.7			14.6			23.5			18.9	
Approach LOS		B			B			C			B	

Intersection Summary		
HCM 2000 Control Delay	15.1	HCM 2000 Level of Service B
HCM 2000 Volume to Capacity ratio	0.54	
Actuated Cycle Length (s)	52.0	Sum of lost time (s) 16.0
Intersection Capacity Utilization	49.6%	ICU Level of Service A
Analysis Period (min)	15	

c Critical Lane Group

HCM 6th TWSC  
7: Driveway 1/Gridley Drive & Shiloh Road

2028 Opening Year Alter. C Project Conditions  
Timing Plan: A.M. PEAK

Intersection												
Int Delay, s/veh	2.1											
Movement	EBL	EBT	EBR	WBL	WBT	WBR	NBL	NBT	NBR	SBL	SBT	SBR
Lane Configurations		↕			↕		↕	↕			↕	
Traffic Vol, veh/h	9	161	64	5	66	0	42	0	3	1	0	18
Future Vol, veh/h	9	161	64	5	66	0	42	0	3	1	0	18
Conflicting Peds, #/hr	0	0	0	0	0	0	0	0	0	0	0	0
Sign Control	Free	Free	Free	Free	Free	Free	Stop	Stop	Stop	Stop	Stop	Stop
RT Channelized	-	-	None	-	-	None	-	-	None	-	-	None
Storage Length	-	-	-	-	-	-	0	-	-	-	-	-
Veh in Median Storage, #	-	0	-	-	0	-	-	0	-	-	0	-
Grade, %	-	0	-	-	0	-	-	0	-	-	0	-
Peak Hour Factor	91	91	91	85	85	85	100	100	100	71	71	71
Heavy Vehicles, %	2	2	2	2	2	2	2	2	2	2	2	2
Mvmt Flow	10	177	70	6	78	0	42	0	3	1	0	25

Major/Minor	Major1			Major2			Minor1			Minor2		
Conflicting Flow All	78	0	0	247	0	0	335	322	212	324	357	78
Stage 1	-	-	-	-	-	-	232	232	-	90	90	-
Stage 2	-	-	-	-	-	-	103	90	-	234	267	-
Critical Hdwy	4.12	-	-	4.12	-	-	7.12	6.52	6.22	7.12	6.52	6.22
Critical Hdwy Stg 1	-	-	-	-	-	-	6.12	5.52	-	6.12	5.52	-
Critical Hdwy Stg 2	-	-	-	-	-	-	6.12	5.52	-	6.12	5.52	-
Follow-up Hdwy	2.218	-	-	2.218	-	-	3.518	4.018	3.318	3.518	4.018	3.318
Pot Cap-1 Maneuver	1520	-	-	1319	-	-	619	595	828	629	569	983
Stage 1	-	-	-	-	-	-	771	713	-	917	820	-
Stage 2	-	-	-	-	-	-	903	820	-	769	688	-
Platoon blocked, %		-	-		-	-						
Mov Cap-1 Maneuver	1520	-	-	1319	-	-	597	587	828	621	562	983
Mov Cap-2 Maneuver	-	-	-	-	-	-	597	587	-	621	562	-
Stage 1	-	-	-	-	-	-	765	707	-	910	816	-
Stage 2	-	-	-	-	-	-	875	816	-	760	682	-

Approach	EB			WB			NB			SB		
HCM Control Delay, s	0.3			0.5			11.4			8.9		
HCM LOS							B			A		

Minor Lane/Major Mvmt	NBLn1	NBLn2	EBL	EBT	EBR	WBL	WBT	WBR	SBLn1
Capacity (veh/h)	597	828	1520	-	-	1319	-	-	954
HCM Lane V/C Ratio	0.07	0.004	0.007	-	-	0.004	-	-	0.028
HCM Control Delay (s)	11.5	9.4	7.4	0	-	7.7	0	-	8.9
HCM Lane LOS	B	A	A	A	-	A	A	-	A
HCM 95th %tile Q(veh)	0.2	0	0	-	-	0	-	-	0.1

Intersection												
Int Delay, s/veh	0.5											
Movement	EBL	EBT	EBR	WBL	WBT	WBR	NBL	NBT	NBR	SBL	SBT	SBR
Lane Configurations		↕		↕	↕			↕		↕	↕	
Traffic Vol, veh/h	1	0	0	6	0	10	0	247	9	15	360	0
Future Vol, veh/h	1	0	0	6	0	10	0	247	9	15	360	0
Conflicting Peds, #/hr	0	0	0	0	0	0	0	0	1	1	0	0
Sign Control	Stop	Stop	Stop	Stop	Stop	Stop	Free	Free	Free	Free	Free	Free
RT Channelized	-	-	None	-	-	None	-	-	None	-	-	None
Storage Length	-	-	-	0	-	-	-	-	-	50	-	-
Veh in Median Storage, #	-	0	-	-	0	-	-	0	-	-	0	-
Grade, %	-	0	-	-	0	-	-	0	-	-	0	-
Peak Hour Factor	25	25	25	100	100	100	99	99	99	90	90	90
Heavy Vehicles, %	2	2	2	2	2	2	2	2	2	2	2	2
Mvmt Flow	4	0	0	6	0	10	0	249	9	17	400	0

Major/Minor	Minor2		Minor1		Major1		Major2					
Conflicting Flow All	693	693	400	689	689	255	400	0	0	259	0	0
Stage 1	434	434	-	255	255	-	-	-	-	-	-	-
Stage 2	259	259	-	434	434	-	-	-	-	-	-	-
Critical Hdwy	7.12	6.52	6.22	7.12	6.52	6.22	4.12	-	-	4.12	-	-
Critical Hdwy Stg 1	6.12	5.52	-	6.12	5.52	-	-	-	-	-	-	-
Critical Hdwy Stg 2	6.12	5.52	-	6.12	5.52	-	-	-	-	-	-	-
Follow-up Hdwy	3.518	4.018	3.318	3.518	4.018	3.318	2.218	-	-	2.218	-	-
Pot Cap-1 Maneuver	358	367	650	360	369	784	1159	-	-	1306	-	-
Stage 1	600	581	-	749	696	-	-	-	-	-	-	-
Stage 2	746	694	-	600	581	-	-	-	-	-	-	-
Platoon blocked, %								-	-	-	-	-
Mov Cap-1 Maneuver	350	362	650	356	364	783	1159	-	-	1305	-	-
Mov Cap-2 Maneuver	350	362	-	356	364	-	-	-	-	-	-	-
Stage 1	600	573	-	748	695	-	-	-	-	-	-	-
Stage 2	736	693	-	592	573	-	-	-	-	-	-	-

Approach	EB	WB	NB	SB
HCM Control Delay, s	15.4	11.8	0	0.3
HCM LOS	C	B		

Minor Lane/Major Mvmt	NBL	NBT	NBR	EBLn1	WBLn1	WBLn2	SBL	SBT	SBR
Capacity (veh/h)	1159	-	-	350	356	783	1305	-	-
HCM Lane V/C Ratio	-	-	-	0.011	0.017	0.013	0.013	-	-
HCM Control Delay (s)	0	-	-	15.4	15.3	9.7	7.8	-	-
HCM Lane LOS	A	-	-	C	C	A	A	-	-
HCM 95th %tile Q(veh)	0	-	-	0	0.1	0	0	-	-

Intersection						
Int Delay, s/veh	0					
Movement	EBT	EBR	WBL	WBT	NBL	NBR
Lane Configurations	↔			↔	↔	↔
Traffic Vol, veh/h	162	0	0	64	0	0
Future Vol, veh/h	162	0	0	64	0	0
Conflicting Peds, #/hr	0	0	0	0	0	0
Sign Control	Free	Free	Free	Free	Stop	Stop
RT Channelized	-	None	-	None	-	None
Storage Length	-	-	-	-	0	0
Veh in Median Storage, #	0	-	-	0	0	-
Grade, %	0	-	-	0	0	-
Peak Hour Factor	85	85	81	81	100	100
Heavy Vehicles, %	2	2	2	2	2	2
Mvmt Flow	191	0	0	79	0	0

Major/Minor	Major1	Major2	Minor1		
Conflicting Flow All	0	0	191	0	270
Stage 1	-	-	-	-	191
Stage 2	-	-	-	-	79
Critical Hdwy	-	-	4.12	-	6.42
Critical Hdwy Stg 1	-	-	-	-	5.42
Critical Hdwy Stg 2	-	-	-	-	5.42
Follow-up Hdwy	-	-	2.218	-	3.518
Pot Cap-1 Maneuver	-	-	1383	-	719
Stage 1	-	-	-	-	841
Stage 2	-	-	-	-	944
Platoon blocked, %	-	-	-	-	-
Mov Cap-1 Maneuver	-	-	1383	-	719
Mov Cap-2 Maneuver	-	-	-	-	719
Stage 1	-	-	-	-	841
Stage 2	-	-	-	-	944

Approach	EB	WB	NB
HCM Control Delay, s	0	0	0
HCM LOS			A

Minor Lane/Major Mvmt	NBLn1	NBLn2	EBT	EBR	WBL	WBT
Capacity (veh/h)	-	-	-	-	1383	-
HCM Lane V/C Ratio	-	-	-	-	-	-
HCM Control Delay (s)	0	0	-	-	0	-
HCM Lane LOS	A	A	-	-	A	-
HCM 95th %tile Q(veh)	-	-	-	-	0	-

HCM 6th Signalized Intersection Summary      2028 Opening Year Alter. C Project Conditions  
 10: US 101 NB Off Ramp/Lakewood Drive & Old Redwood Highway      Timing Plan: A.M. PEAK

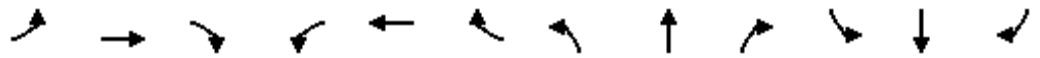

Movement	EBL	EBT	EBR	WBL	WBT	WBR	NBL	NBT	NBR	SBL	SBT	SBR
Lane Configurations	↔↔	↑			↑↑		↔	↔↔		↔↔		↔
Traffic Volume (veh/h)	173	179	0	0	507	170	258	252	90	134	0	608
Future Volume (veh/h)	173	179	0	0	507	170	258	252	90	134	0	608
Initial Q (Qb), veh	0	0	0	0	0	0	0	0	0	0	0	0
Ped-Bike Adj(A_pbT)	1.00		1.00	1.00		0.99	1.00		1.00	1.00		1.00
Parking Bus, Adj	1.00	1.00	1.00	1.00	1.00	1.00	1.00	1.00	1.00	1.00	1.00	1.00
Work Zone On Approach		No			No			No			No	
Adj Sat Flow, veh/h/ln	1870	1870	0	0	1870	1870	1870	1870	1870	1870	0	1870
Adj Flow Rate, veh/h	204	211	0	0	611	205	222	371	100	151	0	0
Peak Hour Factor	0.85	0.85	0.85	0.83	0.83	0.83	0.90	0.90	0.90	0.89	0.89	0.89
Percent Heavy Veh, %	2	2	0	0	2	2	2	2	2	2	0	2
Cap, veh/h	371	1187	0	0	1209	405	375	599	159	0	0	
Arrive On Green	0.11	0.63	0.00	0.00	0.46	0.46	0.21	0.21	0.21	0.00	0.00	0.00
Sat Flow, veh/h	3456	1870	0	0	2698	872	1781	2845	757		0	
Grp Volume(v), veh/h	204	211	0	0	417	399	222	242	229		0.0	
Grp Sat Flow(s),veh/h/ln	1728	1870	0	0	1777	1700	1781	1870	1732			
Q Serve(g_s), s	3.5	2.9	0.0	0.0	10.4	10.4	7.1	7.4	7.6			
Cycle Q Clear(g_c), s	3.5	2.9	0.0	0.0	10.4	10.4	7.1	7.4	7.6			
Prop In Lane	1.00		0.00	0.00		0.51	1.00		0.44			
Lane Grp Cap(c), veh/h	371	1187	0	0	825	789	375	394	365			
V/C Ratio(X)	0.55	0.18	0.00	0.00	0.51	0.51	0.59	0.62	0.63			
Avail Cap(c_a), veh/h	491	1187	0	0	825	789	816	856	793			
HCM Platoon Ratio	1.00	1.00	1.00	1.00	1.00	1.00	1.00	1.00	1.00			
Upstream Filter(I)	1.00	1.00	0.00	0.00	1.00	1.00	1.00	1.00	1.00			
Uniform Delay (d), s/veh	26.8	4.8	0.0	0.0	11.9	11.9	22.5	22.7	22.7			
Incr Delay (d2), s/veh	1.3	0.3	0.0	0.0	2.2	2.3	1.5	1.6	1.8			
Initial Q Delay(d3),s/veh	0.0	0.0	0.0	0.0	0.0	0.0	0.0	0.0	0.0			
%ile BackOfQ(50%),veh/ln	1.4	0.9	0.0	0.0	3.9	3.8	2.9	3.2	3.1			
Unsig. Movement Delay, s/veh												
LnGrp Delay(d),s/veh	28.1	5.1	0.0	0.0	14.1	14.2	24.0	24.2	24.5			
LnGrp LOS	C	A	A	A	B	B	C	C	C			
Approach Vol, veh/h		415			816			693				
Approach Delay, s/veh		16.4			14.1			24.3				
Approach LOS		B			B			C				
Timer - Assigned Phs		2			5	6		8				
Phs Duration (G+Y+Rc), s		45.3			10.8	34.5		18.0				
Change Period (Y+Rc), s		5.1			4.0	5.1		4.7				
Max Green Setting (Gmax), s		40.2			9.0	27.2		29.0				
Max Q Clear Time (g_c+I1), s		4.9			5.5	12.4		9.6				
Green Ext Time (p_c), s		1.2			0.2	4.5		3.4				

**Intersection Summary**

HCM 6th Ctrl Delay	18.3
HCM 6th LOS	B

**Notes**

User approved volume balancing among the lanes for turning movement.  
 Unsignalized Delay for [SBR] is excluded from calculations of the approach delay and intersection delay.



HCM 6th Signalized Intersection Summary      2028 Opening Year Alter. C Project Conditions  
 12: US 101 SB On Ramp/US 101 SB Off Ramp & Old Redwood Highway      Timing Plan: A.M. PEAK



Movement	EBL	EBT	EBR	WBL	WBT	WBR	NBL	NBT	NBR	SBL	SBT	SBR
Lane Configurations		↑↑	↗	↘	↑↑					↖	↕	
Traffic Volume (veh/h)	0	339	337	584	574	0	0	0	0	114	1	74
Future Volume (veh/h)	0	339	337	584	574	0	0	0	0	114	1	74
Initial Q (Qb), veh	0	0	0	0	0	0				0	0	0
Ped-Bike Adj(A_pbT)	1.00		0.98	1.00		1.00				1.00		1.00
Parking Bus, Adj	1.00	1.00	1.00	1.00	1.00	1.00				1.00	1.00	1.00
Work Zone On Approach		No			No						No	
Adj Sat Flow, veh/h/ln	0	1870	1870	1870	1870	0				1870	1870	1870
Adj Flow Rate, veh/h	0	368	366	656	645	0				116	35	0
Peak Hour Factor	0.92	0.92	0.92	0.89	0.89	0.89				0.81	0.81	0.81
Percent Heavy Veh, %	0	2	2	2	2	0				2	2	2
Cap, veh/h	0	1214	533	649	2686	0				216	227	
Arrive On Green	0.00	0.34	0.34	0.36	0.76	0.00				0.12	0.12	0.00
Sat Flow, veh/h	0	3647	1560	1781	3647	0				1781	1870	0
Grp Volume(v), veh/h	0	368	366	656	645	0				116	35	0
Grp Sat Flow(s),veh/h/ln	0	1777	1560	1781	1777	0				1781	1870	0
Q Serve(g_s), s	0.0	6.1	16.1	29.0	4.3	0.0				4.9	1.3	0.0
Cycle Q Clear(g_c), s	0.0	6.1	16.1	29.0	4.3	0.0				4.9	1.3	0.0
Prop In Lane	0.00		1.00	1.00		0.00				1.00		0.00
Lane Grp Cap(c), veh/h	0	1214	533	649	2686	0				216	227	
V/C Ratio(X)	0.00	0.30	0.69	1.01	0.24	0.00				0.54	0.15	
Avail Cap(c_a), veh/h	0	1214	533	649	2686	0				224	235	
HCM Platoon Ratio	1.00	1.00	1.00	1.00	1.00	1.00				1.00	1.00	1.00
Upstream Filter(I)	0.00	1.00	1.00	1.00	1.00	0.00				1.00	1.00	0.00
Uniform Delay (d), s/veh	0.0	19.3	22.6	25.3	2.9	0.0				32.9	31.3	0.0
Incr Delay (d2), s/veh	0.0	0.6	7.1	38.2	0.2	0.0				2.4	0.3	0.0
Initial Q Delay(d3),s/veh	0.0	0.0	0.0	0.0	0.0	0.0				0.0	0.0	0.0
%ile BackOfQ(50%),veh/ln	0.0	2.5	6.5	18.1	1.0	0.0				2.2	0.6	0.0
Unsig. Movement Delay, s/veh												
LnGrp Delay(d),s/veh	0.0	19.9	29.6	63.5	3.1	0.0				35.3	31.7	0.0
LnGrp LOS	A	B	C	F	A	A				D	C	
Approach Vol, veh/h		734			1301						151	
Approach Delay, s/veh		24.8			33.6						34.4	
Approach LOS		C			C						C	
Timer - Assigned Phs		2			5	6		8				
Phs Duration (G+Y+Rc), s		65.3			33.0	32.3		14.3				
Change Period (Y+Rc), s		5.1			4.0	5.1		4.7				
Max Green Setting (Gmax), s		60.2			29.0	27.2		10.0				
Max Q Clear Time (g_c+I1), s		6.3			31.0	18.1		6.9				
Green Ext Time (p_c), s		5.0			0.0	2.6		0.1				

**Intersection Summary**























HCM 6th Ctrl Delay	30.7
HCM 6th LOS	C

**Notes**

- User approved volume balancing among the lanes for turning movement.
- User approved ignoring U-Turning movement.
- Unsignalized Delay for [SBR] is excluded from calculations of the approach delay and intersection delay.

























HCM 6th Signalized Intersection Summary  
1: Old Redwood Hwy & Shiloh Road

2028 Opening Year Alter. C Project Conditions  
Timing Plan: P.M. Peak

												
Movement	EBL	EBT	EBR	WBL	WBT	WBR	NBL	NBT	NBR	SBL	SBT	SBR
Lane Configurations												
Traffic Volume (veh/h)	290	161	222	42	150	25	199	388	24	34	271	183
Future Volume (veh/h)	290	161	222	42	150	25	199	388	24	34	271	183
Initial Q (Qb), veh	0	0	0	0	0	0	0	0	0	0	0	0
Ped-Bike Adj(A_pbT)	1.00		1.00	1.00		1.00	1.00		0.97	1.00		0.97
Parking Bus, Adj	1.00	1.00	1.00	1.00	1.00	1.00	1.00	1.00	1.00	1.00	1.00	1.00
Work Zone On Approach		No			No			No			No	
Adj Sat Flow, veh/h/ln	1870	1870	1870	1870	1870	1870	1870	1870	1870	1870	1870	1870
Adj Flow Rate, veh/h	299	166	229	46	165	27	214	417	26	37	291	197
Peak Hour Factor	0.97	0.97	0.97	0.91	0.91	0.91	0.93	0.93	0.93	0.93	0.93	0.93
Percent Heavy Veh, %	2	2	2	2	2	2	2	2	2	2	2	2
Cap, veh/h	400	420	355	64	229	250	266	541	446	133	401	330
Arrive On Green	0.22	0.22	0.22	0.16	0.16	0.16	0.15	0.29	0.29	0.07	0.21	0.21
Sat Flow, veh/h	1781	1870	1582	403	1447	1580	1781	1870	1545	1781	1870	1542
Grp Volume(v), veh/h	299	166	229	211	0	27	214	417	26	37	291	197
Grp Sat Flow(s),veh/h/ln	1781	1870	1582	1850	0	1580	1781	1870	1545	1781	1870	1542
Q Serve(g_s), s	10.5	5.1	8.8	7.3	0.0	1.0	7.8	13.7	0.8	1.3	9.7	7.7
Cycle Q Clear(g_c), s	10.5	5.1	8.8	7.3	0.0	1.0	7.8	13.7	0.8	1.3	9.7	7.7
Prop In Lane	1.00		1.00	0.22		1.00	1.00		1.00	1.00		1.00
Lane Grp Cap(c), veh/h	400	420	355	293	0	250	266	541	446	133	401	330
V/C Ratio(X)	0.75	0.40	0.65	0.72	0.00	0.11	0.80	0.77	0.06	0.28	0.73	0.60
Avail Cap(c_a), veh/h	811	851	720	1049	0	896	385	1214	1002	159	977	805
HCM Platoon Ratio	1.00	1.00	1.00	1.00	1.00	1.00	1.00	1.00	1.00	1.00	1.00	1.00
Upstream Filter(I)	1.00	1.00	1.00	1.00	0.00	1.00	1.00	1.00	1.00	1.00	1.00	1.00
Uniform Delay (d), s/veh	24.2	22.1	23.6	26.8	0.0	24.2	27.6	21.8	17.2	29.3	24.5	23.7
Incr Delay (d2), s/veh	2.8	0.6	2.0	3.3	0.0	0.2	7.7	2.4	0.1	1.1	2.5	1.7
Initial Q Delay(d3),s/veh	0.0	0.0	0.0	0.0	0.0	0.0	0.0	0.0	0.0	0.0	0.0	0.0
%ile BackOfQ(50%),veh/ln	4.3	2.1	3.1	3.2	0.0	0.3	3.6	5.5	0.3	0.6	4.2	2.7
Unsig. Movement Delay, s/veh												
LnGrp Delay(d),s/veh	27.0	22.7	25.5	30.1	0.0	24.3	35.3	24.2	17.3	30.4	27.0	25.5
LnGrp LOS	C	C	C	C	A	C	D	C	B	C	C	C
Approach Vol, veh/h		694			238			657			525	
Approach Delay, s/veh		25.5			29.5			27.5			26.7	
Approach LOS		C			C			C			C	
Timer - Assigned Phs		2	3	4		6	7	8				
Phs Duration (G+Y+Rc), s		19.5	13.5	18.9		15.1	8.5	23.9				
Change Period (Y+Rc), s		4.5	3.5	4.5		4.5	3.5	4.5				
Max Green Setting (Gmax), s		30.5	14.5	35.0		38.0	6.0	43.5				
Max Q Clear Time (g_c+I1), s		12.5	9.8	11.7		9.3	3.3	15.7				
Green Ext Time (p_c), s		2.4	0.2	2.3		1.2	0.0	2.5				
<b>Intersection Summary</b>												
HCM 6th Ctrl Delay			26.9									
HCM 6th LOS			C									

HCM 6th Signalized Intersection Summary  
2: Shiloh Road & Hembree Ln

2028 Opening Year Alter. C Project Conditions  
Timing Plan: P.M. Peak

												
Movement	EBL	EBT	EBR	WBL	WBT	WBR	NBL	NBT	NBR	SBL	SBT	SBR
Lane Configurations	 			 	 						 	
Traffic Volume (veh/h)	700	512	44	24	395	165	65	11	15	194	11	565
Future Volume (veh/h)	700	512	44	24	395	165	65	11	15	194	11	565
Initial Q (Qb), veh	0	0	0	0	0	0	0	0	0	0	0	0
Ped-Bike Adj(A_pbT)	1.00		1.00	1.00		1.00	1.00		1.00	1.00		1.00
Parking Bus, Adj	1.00	1.00	1.00	1.00	1.00	1.00	1.00	1.00	1.00	1.00	1.00	1.00
Work Zone On Approach		No			No			No			No	
Adj Sat Flow, veh/h/ln	1870	1870	1870	1870	1870	1870	1870	1870	1870	1870	1870	1870
Adj Flow Rate, veh/h	745	545	44	24	454	190	65	11	15	204	11	595
Peak Hour Factor	0.94	0.94	1.00	1.00	0.87	0.87	1.00	1.00	1.00	0.95	1.00	0.95
Percent Heavy Veh, %	2	2	2	2	2	2	2	2	2	2	2	2
Cap, veh/h	860	848	68	48	673	279	113	45	62	269	15	646
Arrive On Green	0.25	0.50	0.50	0.03	0.28	0.28	0.06	0.06	0.06	0.16	0.16	0.16
Sat Flow, veh/h	3456	1707	138	1781	2446	1015	1781	717	978	1694	91	1585
Grp Volume(v), veh/h	745	0	589	24	329	315	65	0	26	215	0	595
Grp Sat Flow(s),veh/h/ln	1728	0	1845	1781	1777	1685	1781	0	1694	1786	0	1585
Q Serve(g_s), s	13.0	0.0	14.9	0.8	10.4	10.5	2.2	0.0	0.9	7.3	0.0	10.0
Cycle Q Clear(g_c), s	13.0	0.0	14.9	0.8	10.4	10.5	2.2	0.0	0.9	7.3	0.0	10.0
Prop In Lane	1.00		0.07	1.00		0.60	1.00		0.58	0.95		1.00
Lane Grp Cap(c), veh/h	860	0	917	48	489	464	113	0	107	283	0	646
V/C Ratio(X)	0.87	0.00	0.64	0.49	0.67	0.68	0.58	0.00	0.24	0.76	0.00	0.92
Avail Cap(c_a), veh/h	933	0	1553	156	1171	1110	156	0	148	283	0	646
HCM Platoon Ratio	1.00	1.00	1.00	1.00	1.00	1.00	1.00	1.00	1.00	1.00	1.00	1.00
Upstream Filter(I)	1.00	0.00	1.00	1.00	1.00	1.00	1.00	0.00	1.00	1.00	0.00	1.00
Uniform Delay (d), s/veh	22.7	0.0	11.7	30.2	20.3	20.4	28.7	0.0	28.1	25.3	0.0	17.7
Incr Delay (d2), s/veh	8.2	0.0	0.8	7.6	1.6	1.8	4.6	0.0	1.2	11.2	0.0	18.6
Initial Q Delay(d3),s/veh	0.0	0.0	0.0	0.0	0.0	0.0	0.0	0.0	0.0	0.0	0.0	0.0
%ile BackOfQ(50%),veh/ln	5.6	0.0	4.9	0.4	4.0	3.9	1.1	0.0	0.4	3.7	0.0	10.5
Unsig. Movement Delay, s/veh												
LnGrp Delay(d),s/veh	30.8	0.0	12.5	37.8	21.9	22.1	33.3	0.0	29.2	36.6	0.0	36.3
LnGrp LOS	C	A	B	D	C	C	C	A	C	D	A	D
Approach Vol, veh/h		1334			668			91				810
Approach Delay, s/veh		22.7			22.6			32.1				36.4
Approach LOS		C			C			C				D
Timer - Assigned Phs	1	2		4	5	6		8				
Phs Duration (G+Y+Rc), s	5.7	35.3		14.0	19.7	21.3		8.0				
Change Period (Y+Rc), s	4.0	4.0		4.0	4.0	4.0		4.0				
Max Green Setting (Gmax), s	5.5	53.0		10.0	17.0	41.5		5.5				
Max Q Clear Time (g_c+I1), s	2.8	16.9		12.0	15.0	12.5		4.2				
Green Ext Time (p_c), s	0.0	4.1		0.0	0.7	4.0		0.0				
<b>Intersection Summary</b>												
HCM 6th Ctrl Delay				26.8								
HCM 6th LOS				C								

HCM 6th Signalized Intersection Summary  
 3: US 101 NB Off-Ramp & Shiloh Road

2028 Opening Year Alter. C Project Conditions  
 Timing Plan: P.M. Peak



Movement	EBT	EBR	WBL	WBT	NBL	NBR
Lane Configurations	↑↑			↑	↘	↗
Traffic Volume (veh/h)	466	0	0	716	599	795
Future Volume (veh/h)	466	0	0	716	599	795
Initial Q (Qb), veh	0	0	0	0	0	0
Ped-Bike Adj(A_pbT)		1.00	1.00		1.00	1.00
Parking Bus, Adj	1.00	1.00	1.00	1.00	1.00	1.00
Work Zone On Approach	No			No	No	
Adj Sat Flow, veh/h/ln	1870	0	0	1870	1870	1870
Adj Flow Rate, veh/h	496	0	0	738	666	883
Peak Hour Factor	0.94	0.94	0.97	0.97	0.90	0.90
Percent Heavy Veh, %	2	0	0	2	2	2
Cap, veh/h	1569	0	0	826	770	1207
Arrive On Green	0.44	0.00	0.00	0.44	0.43	0.43
Sat Flow, veh/h	3741	0	0	1870	1781	2790
Grp Volume(v), veh/h	496	0	0	738	666	883
Grp Sat Flow(s),veh/h/ln	1777	0	0	1870	1781	1395
Q Serve(g_s), s	5.8	0.0	0.0	23.1	21.5	16.7
Cycle Q Clear(g_c), s	5.8	0.0	0.0	23.1	21.5	16.7
Prop In Lane		0.00	0.00		1.00	1.00
Lane Grp Cap(c), veh/h	1569	0	0	826	770	1207
V/C Ratio(X)	0.32	0.00	0.00	0.89	0.86	0.73
Avail Cap(c_a), veh/h	1845	0	0	971	869	1361
HCM Platoon Ratio	1.00	1.00	1.00	1.00	1.00	1.00
Upstream Filter(I)	1.00	0.00	0.00	1.00	1.00	1.00
Uniform Delay (d), s/veh	11.5	0.0	0.0	16.4	16.3	15.0
Incr Delay (d2), s/veh	0.1	0.0	0.0	9.5	8.3	1.8
Initial Q Delay(d3),s/veh	0.0	0.0	0.0	0.0	0.0	0.0
%ile BackOfQ(50%),veh/ln	1.9	0.0	0.0	10.1	9.4	4.9
Unsig. Movement Delay, s/veh						
LnGrp Delay(d),s/veh	11.6	0.0	0.0	25.9	24.7	16.8
LnGrp LOS	B	A	A	C	C	B
Approach Vol, veh/h	496			738	1549	
Approach Delay, s/veh	11.6			25.9	20.2	
Approach LOS	B			C	C	
Timer - Assigned Phs		2			6	8
Phs Duration (G+Y+Rc), s		32.1			32.1	31.5
Change Period (Y+Rc), s		4.0			4.0	4.0
Max Green Setting (Gmax), s		33.0			33.0	31.0
Max Q Clear Time (g_c+I1), s		7.8			25.1	23.5
Green Ext Time (p_c), s		3.2			2.9	4.0
<b>Intersection Summary</b>						
HCM 6th Ctrl Delay			20.2			
HCM 6th LOS			C			

HCM Signalized Intersection Capacity Analysis 2028 Opening Year Alter. C Project Conditions  
 4: Shiloh Road & US 101 SB Off-Ramp

Timing Plan: P.M. Peak



Movement	EBL	EBT	WBT	WBR	SBL	SBR
Lane Configurations		↑	↑		↙	↗
Traffic Volume (vph)	0	503	719	0	166	146
Future Volume (vph)	0	503	719	0	166	146
Ideal Flow (vphpl)	1900	1900	1900	1900	1900	1900
Total Lost time (s)		4.0	4.0		4.0	4.0
Lane Util. Factor		1.00	1.00		1.00	1.00
Frbp, ped/bikes		1.00	1.00		1.00	0.98
Flpb, ped/bikes		1.00	1.00		1.00	1.00
Frt		1.00	1.00		1.00	0.85
Flt Protected		1.00	1.00		0.95	1.00
Satd. Flow (prot)		1863	1863		1770	1548
Flt Permitted		1.00	1.00		0.95	1.00
Satd. Flow (perm)		1863	1863		1770	1548
Peak-hour factor, PHF	0.89	0.89	0.96	0.96	0.93	0.93
Adj. Flow (vph)	0	565	749	0	178	157
RTOR Reduction (vph)	0	0	0	0	0	119
Lane Group Flow (vph)	0	565	749	0	178	38
Confl. Peds. (#/hr)						1
Turn Type		NA	NA		Perm	Perm
Protected Phases		2	6			
Permitted Phases					4	4
Actuated Green, G (s)		24.1	24.1		10.1	10.1
Effective Green, g (s)		24.1	24.1		10.1	10.1
Actuated g/C Ratio		0.57	0.57		0.24	0.24
Clearance Time (s)		4.0	4.0		4.0	4.0
Vehicle Extension (s)		3.0	3.0		3.0	3.0
Lane Grp Cap (vph)		1063	1063		423	370
v/s Ratio Prot		0.30	c0.40			
v/s Ratio Perm					c0.10	0.02
v/c Ratio		0.53	0.70		0.42	0.10
Uniform Delay, d1		5.6	6.5		13.6	12.5
Progression Factor		1.00	1.00		1.00	1.00
Incremental Delay, d2		0.5	2.1		0.7	0.1
Delay (s)		6.1	8.6		14.3	12.6
Level of Service		A	A		B	B
Approach Delay (s)		6.1	8.6		13.5	
Approach LOS		A	A		B	
<b>Intersection Summary</b>						
HCM 2000 Control Delay			8.8		HCM 2000 Level of Service	A
HCM 2000 Volume to Capacity ratio			0.62			
Actuated Cycle Length (s)			42.2		Sum of lost time (s)	8.0
Intersection Capacity Utilization			70.2%		ICU Level of Service	C
Analysis Period (min)			15			
c Critical Lane Group						

Intersection						
Int Delay, s/veh	3.4					
Movement	EBT	EBR	WBL	WBT	NBL	NBR
Lane Configurations	↑↑		↖	↑	↖	↖
Traffic Vol, veh/h	974	32	90	746	17	170
Future Vol, veh/h	974	32	90	746	17	170
Conflicting Peds, #/hr	0	0	0	0	0	0
Sign Control	Free	Free	Free	Free	Stop	Stop
RT Channelized	-	None	-	None	-	None
Storage Length	-	-	68	-	0	0
Veh in Median Storage, #	0	-	-	0	0	-
Grade, %	0	-	-	0	0	-
Peak Hour Factor	89	89	92	92	89	89
Heavy Vehicles, %	2	2	2	2	2	2
Mvmt Flow	1094	36	98	811	19	191



















Major/Minor	Major1	Major2	Minor1		
Conflicting Flow All	0	0	1130	0	2119
Stage 1	-	-	-	-	1112
Stage 2	-	-	-	-	1007
Critical Hdwy	-	-	4.13	-	6.63
Critical Hdwy Stg 1	-	-	-	-	5.83
Critical Hdwy Stg 2	-	-	-	-	5.43
Follow-up Hdwy	-	-	2.219	-	3.519
Pot Cap-1 Maneuver	-	-	616	-	49
Stage 1	-	-	-	-	277
Stage 2	-	-	-	-	352
Platoon blocked, %	-	-	-	-	-
Mov Cap-1 Maneuver	-	-	616	-	41
Mov Cap-2 Maneuver	-	-	-	-	41
Stage 1	-	-	-	-	277
Stage 2	-	-	-	-	296

Approach	EB	WB	NB
HCM Control Delay, s	0	1.3	30.3
HCM LOS			D

Minor Lane/Major Mvmt	NBLn1	NBLn2	EBT	EBR	WBL	WBT
Capacity (veh/h)	41	469	-	-	616	-
HCM Lane V/C Ratio	0.466	0.407	-	-	0.159	-
HCM Control Delay (s)	153.9	17.9	-	-	11.9	-
HCM Lane LOS	F	C	-	-	B	-
HCM 95th %tile Q(veh)	1.6	2	-	-	0.6	-

HCM Signalized Intersection Capacity Analysis 2028 Opening Year Alter. C Project Conditions  
 6: Conde Lane & Shiloh Road

Timing Plan: P.M. Peak

													
Movement	EBL	EBT	EBR	WBL	WBT	WBR	NBL	NBT	NBR	SBL	SBT	SBR	
Lane Configurations													
Traffic Volume (vph)	79	540	2	8	524	329	6	3	19	338	0	44	
Future Volume (vph)	79	540	2	8	524	329	6	3	19	338	0	44	
Ideal Flow (vphp)	1900	1900	1900	1900	1900	1900	1900	1900	1900	1900	1900	1900	
Total Lost time (s)	4.0	4.0		4.0	4.0			4.0			4.0	4.0	
Lane Util. Factor	1.00	0.95		1.00	0.95			1.00			1.00	1.00	
Frbp, ped/bikes	1.00	1.00		1.00	0.99			1.00			1.00	1.00	
Flpb, ped/bikes	1.00	1.00		1.00	1.00			1.00			1.00	1.00	
Frt	1.00	1.00		1.00	0.94			0.91			1.00	0.85	
Flt Protected	0.95	1.00		0.95	1.00			0.99			0.95	1.00	
Satd. Flow (prot)	1770	3537		1770	3307			1676			1770	1583	
Flt Permitted	0.95	1.00		0.95	1.00			0.99			0.95	1.00	
Satd. Flow (perm)	1770	3537		1770	3307			1676			1770	1583	
Peak-hour factor, PHF	0.88	0.88	0.88	0.80	0.80	0.80	0.63	0.63	0.63	0.88	0.88	0.88	
Adj. Flow (vph)	90	614	2	10	655	411	10	5	30	384	0	50	
RTOR Reduction (vph)	0	0	0	0	82	0	0	28	0	0	0	0	
Lane Group Flow (vph)	90	616	0	10	984	0	0	17	0	0	384	50	
Confl. Peds. (#/hr)	1					1							
Turn Type	Prot	NA		Prot	NA		Split	NA		Split	NA	custom	
Protected Phases	5	2		1	6		7	7		4	4		
Permitted Phases												6	
Actuated Green, G (s)	6.4	34.8		1.2	29.6			4.9			12.6	29.6	
Effective Green, g (s)	6.4	34.8		1.2	29.6			4.9			12.6	29.6	
Actuated g/C Ratio	0.09	0.50		0.02	0.43			0.07			0.18	0.43	
Clearance Time (s)	4.0	4.0		4.0	4.0			4.0			4.0	4.0	
Vehicle Extension (s)	3.0	3.0		3.0	3.0			3.0			3.0	3.0	
Lane Grp Cap (vph)	162	1771		30	1408			118			320	674	
v/s Ratio Prot	c0.05	0.17		0.01	c0.30			c0.01			c0.22		
v/s Ratio Perm												0.03	
v/c Ratio	0.56	0.35		0.33	0.70			0.15			1.20	0.07	
Uniform Delay, d1	30.2	10.5		33.8	16.3			30.3			28.4	11.8	
Progression Factor	1.00	1.00		1.00	1.00			1.00			1.00	1.00	
Incremental Delay, d2	4.1	0.1		6.5	1.5			0.6			116.2	0.0	
Delay (s)	34.3	10.6		40.2	17.8			30.9			144.6	11.9	
Level of Service	C	B		D	B			C			F	B	
Approach Delay (s)		13.6			18.1			30.9			129.3		
Approach LOS		B			B			C			F		
<b>Intersection Summary</b>													
HCM 2000 Control Delay			38.3									HCM 2000 Level of Service	D
HCM 2000 Volume to Capacity ratio			0.75										
Actuated Cycle Length (s)			69.5									Sum of lost time (s)	16.0
Intersection Capacity Utilization			67.1%									ICU Level of Service	C
Analysis Period (min)			15										
c Critical Lane Group													

Intersection												
Int Delay, s/veh	2.6											
Movement	EBL	EBT	EBR	WBL	WBT	WBR	NBL	NBT	NBR	SBL	SBT	SBR
Lane Configurations		↕			↕		↕	↕			↕	
Traffic Vol, veh/h	19	117	70	5	142	0	66	0	5	0	0	16
Future Vol, veh/h	19	117	70	5	142	0	66	0	5	0	0	16
Conflicting Peds, #/hr	1	0	0	0	0	0	0	0	0	0	0	0
Sign Control	Free	Free	Free	Free	Free	Free	Stop	Stop	Stop	Stop	Stop	Stop
RT Channelized	-	-	None	-	-	None	-	-	None	-	-	None
Storage Length	-	-	-	-	-	-	0	-	-	-	-	-
Veh in Median Storage, #	-	0	-	-	0	-	-	0	-	-	0	-
Grade, %	-	0	-	-	0	-	-	0	-	-	0	-
Peak Hour Factor	94	94	94	69	69	69	100	100	100	58	58	58
Heavy Vehicles, %	2	2	2	2	2	2	2	2	2	2	2	2
Mvmt Flow	20	124	74	7	206	0	66	0	5	0	0	28

Major/Minor	Major1			Major2			Minor1			Minor2		
Conflicting Flow All	207	0	0	198	0	0	435	422	161	425	459	207
Stage 1	-	-	-	-	-	-	201	201	-	221	221	-
Stage 2	-	-	-	-	-	-	234	221	-	204	238	-
Critical Hdwy	4.12	-	-	4.12	-	-	7.12	6.52	6.22	7.12	6.52	6.22
Critical Hdwy Stg 1	-	-	-	-	-	-	6.12	5.52	-	6.12	5.52	-
Critical Hdwy Stg 2	-	-	-	-	-	-	6.12	5.52	-	6.12	5.52	-
Follow-up Hdwy	2.218	-	-	2.218	-	-	3.518	4.018	3.318	3.518	4.018	3.318
Pot Cap-1 Maneuver	1364	-	-	1375	-	-	531	523	884	540	499	833
Stage 1	-	-	-	-	-	-	801	735	-	781	720	-
Stage 2	-	-	-	-	-	-	769	720	-	798	708	-
Platoon blocked, %		-	-		-	-						
Mov Cap-1 Maneuver	1363	-	-	1375	-	-	504	510	884	527	487	832
Mov Cap-2 Maneuver	-	-	-	-	-	-	504	510	-	527	487	-
Stage 1	-	-	-	-	-	-	787	723	-	767	715	-
Stage 2	-	-	-	-	-	-	739	715	-	780	696	-

Approach	EB			WB			NB			SB		
HCM Control Delay, s	0.7			0.3			12.9			9.5		
HCM LOS							B			A		

Minor Lane/Major Mvmt	NBLn1	NBLn2	EBL	EBT	EBR	WBL	WBT	WBR	SBLn1
Capacity (veh/h)	504	884	1363	-	-	1375	-	-	832
HCM Lane V/C Ratio	0.131	0.006	0.015	-	-	0.005	-	-	0.033
HCM Control Delay (s)	13.2	9.1	7.7	0	-	7.6	0	-	9.5
HCM Lane LOS	B	A	A	A	-	A	A	-	A
HCM 95th %tile Q(veh)	0.4	0	0	-	-	0	-	-	0.1



HCM 6th TWSC  
8: Old Redwood Hwy & Driveway 2

2028 Opening Year Alter. C Project Conditions  
Timing Plan: P.M. Peak

Intersection												
Int Delay, s/veh	0.7											
Movement	EBL	EBT	EBR	WBL	WBT	WBR	NBL	NBT	NBR	SBL	SBT	SBR
Lane Configurations		↕		↗	↘			↕		↗	↘	
Traffic Vol, veh/h	3	0	0	9	0	15	0	575	10	16	486	0
Future Vol, veh/h	3	0	0	9	0	15	0	575	10	16	486	0
Conflicting Peds, #/hr	0	0	0	0	0	0	0	0	0	0	0	0
Sign Control	Stop	Stop	Stop	Stop	Stop	Stop	Free	Free	Free	Free	Free	Free
RT Channelized	-	-	None	-	-	None	-	-	None	-	-	None
Storage Length	-	-	-	0	-	-	-	-	-	50	-	-
Veh in Median Storage, #	-	0	-	-	0	-	-	0	-	-	0	-
Grade, %	-	0	-	-	0	-	-	0	-	-	0	-
Peak Hour Factor	38	38	38	100	100	100	91	91	91	94	94	94
Heavy Vehicles, %	2	2	2	2	2	2	2	2	2	2	2	2
Mvmt Flow	8	0	0	9	0	15	0	632	11	17	517	0

Major/Minor	Minor2		Minor1		Major1		Major2					
Conflicting Flow All	1196	1194	517	1189	1189	638	517	0	0	643	0	0
Stage 1	551	551	-	638	638	-	-	-	-	-	-	-
Stage 2	645	643	-	551	551	-	-	-	-	-	-	-
Critical Hdwy	7.12	6.52	6.22	7.12	6.52	6.22	4.12	-	-	4.12	-	-
Critical Hdwy Stg 1	6.12	5.52	-	6.12	5.52	-	-	-	-	-	-	-
Critical Hdwy Stg 2	6.12	5.52	-	6.12	5.52	-	-	-	-	-	-	-
Follow-up Hdwy	3.518	4.018	3.318	3.518	4.018	3.318	2.218	-	-	2.218	-	-
Pot Cap-1 Maneuver	163	187	558	165	188	477	1049	-	-	942	-	-
Stage 1	519	515	-	465	471	-	-	-	-	-	-	-
Stage 2	461	468	-	519	515	-	-	-	-	-	-	-
Platoon blocked, %								-	-	-	-	-
Mov Cap-1 Maneuver	156	184	558	163	185	477	1049	-	-	942	-	-
Mov Cap-2 Maneuver	156	184	-	163	185	-	-	-	-	-	-	-
Stage 1	519	506	-	465	471	-	-	-	-	-	-	-
Stage 2	447	468	-	510	506	-	-	-	-	-	-	-

Approach	EB		WB		NB		SB	
HCM Control Delay, s	29.3		18.7		0		0.3	
HCM LOS	D		C					

Minor Lane/Major Mvmt	NBL	NBT	NBR	EBLn1	WBLn1	WBLn2	SBL	SBT	SBR
Capacity (veh/h)	1049	-	-	156	163	477	942	-	-
HCM Lane V/C Ratio	-	-	-	0.051	0.055	0.031	0.018	-	-
HCM Control Delay (s)	0	-	-	29.3	28.4	12.8	8.9	-	-
HCM Lane LOS	A	-	-	D	D	B	A	-	-
HCM 95th %tile Q(veh)	0	-	-	0.2	0.2	0.1	0.1	-	-

Intersection						
Int Delay, s/veh	0					
Movement	EBT	EBR	WBL	WBT	NBL	NBR
Lane Configurations	↔			↔	↔	↔
Traffic Vol, veh/h	97	0	0	131	0	0
Future Vol, veh/h	97	0	0	131	0	0
Conflicting Peds, #/hr	0	0	0	0	0	0
Sign Control	Free	Free	Free	Free	Stop	Stop
RT Channelized	-	None	-	None	-	None
Storage Length	-	-	-	-	0	0
Veh in Median Storage, #	0	-	-	0	0	-
Grade, %	0	-	-	0	0	-
Peak Hour Factor	92	92	68	68	100	100
Heavy Vehicles, %	2	2	2	2	2	2
Mvmt Flow	105	0	0	193	0	0

Major/Minor	Major1	Major2	Minor1		
Conflicting Flow All	0	0	105	0	298
Stage 1	-	-	-	-	105
Stage 2	-	-	-	-	193
Critical Hdwy	-	-	4.12	-	6.42
Critical Hdwy Stg 1	-	-	-	-	5.42
Critical Hdwy Stg 2	-	-	-	-	5.42
Follow-up Hdwy	-	-	2.218	-	3.518
Pot Cap-1 Maneuver	-	-	1486	-	693
Stage 1	-	-	-	-	919
Stage 2	-	-	-	-	840
Platoon blocked, %	-	-	-	-	-
Mov Cap-1 Maneuver	-	-	1486	-	693
Mov Cap-2 Maneuver	-	-	-	-	693
Stage 1	-	-	-	-	919
Stage 2	-	-	-	-	840

Approach	EB	WB	NB
HCM Control Delay, s	0	0	0
HCM LOS			A

Minor Lane/Major Mvmt	NBLn1	NBLn2	EBT	EBR	WBL	WBT
Capacity (veh/h)	-	-	-	-	1486	-
HCM Lane V/C Ratio	-	-	-	-	-	-
HCM Control Delay (s)	0	0	-	-	0	-
HCM Lane LOS	A	A	-	-	A	-
HCM 95th %tile Q(veh)	-	-	-	-	0	-

HCM 6th Signalized Intersection Summary      2028 Opening Year Alter. C Project Conditions  
 10: US 101 NB Off Ramp/Lakewood Drive & Old Redwood Highway      Timing Plan: P.M. Peak

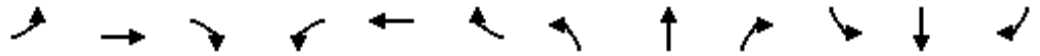

Movement	EBL	EBT	EBR	WBL	WBT	WBR	NBL	NBT	NBR	SBL	SBT	SBR
Lane Configurations	↔↔	↑			↑↑		↔	↔↔		↔↔		↔
Traffic Volume (veh/h)	297	409	0	0	575	219	569	469	286	284	0	657
Future Volume (veh/h)	297	409	0	0	575	219	569	469	286	284	0	657
Initial Q (Qb), veh	0	0	0	0	0	0	0	0	0	0	0	0
Ped-Bike Adj(A_pbT)	1.00		1.00	1.00		0.98	1.00		0.99	1.00		1.00
Parking Bus, Adj	1.00	1.00	1.00	1.00	1.00	1.00	1.00	1.00	1.00	1.00	1.00	1.00
Work Zone On Approach		No			No			No			No	
Adj Sat Flow, veh/h/ln	1870	1870	0	0	1870	1870	1870	1870	1870	1870	0	1870
Adj Flow Rate, veh/h	341	470	0	0	632	241	480	704	311	296	0	0
Peak Hour Factor	0.87	0.87	0.87	0.91	0.91	0.91	0.92	0.92	0.92	0.96	0.96	0.96
Percent Heavy Veh, %	2	2	0	0	2	2	2	2	2	2	0	2
Cap, veh/h	405	980	0	0	887	338	620	854	377	0	0	0
Arrive On Green	0.12	0.52	0.00	0.00	0.35	0.35	0.35	0.35	0.35	0.00	0.00	0.00
Sat Flow, veh/h	3456	1870	0	0	2594	953	1781	2453	1084		0	
Grp Volume(v), veh/h	341	470	0	0	449	424	480	537	478		0.0	
Grp Sat Flow(s),veh/h/ln	1728	1870	0	0	1777	1676	1781	1870	1666			
Q Serve(g_s), s	7.4	12.3	0.0	0.0	16.7	16.8	18.4	20.1	20.1			
Cycle Q Clear(g_c), s	7.4	12.3	0.0	0.0	16.7	16.8	18.4	20.1	20.1			
Prop In Lane	1.00		0.00	0.00		0.57	1.00		0.65			
Lane Grp Cap(c), veh/h	405	980	0	0	630	594	620	651	580			
V/C Ratio(X)	0.84	0.48	0.00	0.00	0.71	0.71	0.77	0.82	0.82			
Avail Cap(c_a), veh/h	405	980	0	0	630	594	673	707	630			
HCM Platoon Ratio	1.00	1.00	1.00	1.00	1.00	1.00	1.00	1.00	1.00			
Upstream Filter(I)	1.00	1.00	0.00	0.00	1.00	1.00	1.00	1.00	1.00			
Uniform Delay (d), s/veh	33.2	11.6	0.0	0.0	21.4	21.4	22.3	22.9	22.9			
Incr Delay (d2), s/veh	14.6	1.7	0.0	0.0	6.7	7.1	5.2	7.4	8.2			
Initial Q Delay(d3),s/veh	0.0	0.0	0.0	0.0	0.0	0.0	0.0	0.0	0.0			
%ile BackOfQ(50%),veh/ln	3.8	4.9	0.0	0.0	7.6	7.2	8.1	9.6	8.7			
Unsig. Movement Delay, s/veh												
LnGrp Delay(d),s/veh	47.8	13.3	0.0	0.0	28.1	28.5	27.5	30.2	31.1			
LnGrp LOS	D	B	A	A	C	C	C	C	C			
Approach Vol, veh/h		811			873			1495				
Approach Delay, s/veh		27.8			28.3			29.6				
Approach LOS		C			C			C				
Timer - Assigned Phs		2			5	6		8				
Phs Duration (G+Y+Rc), s		45.3			13.0	32.3		31.4				
Change Period (Y+Rc), s		5.1			4.0	5.1		4.7				
Max Green Setting (Gmax), s		40.2			9.0	27.2		29.0				
Max Q Clear Time (g_c+I1), s		14.3			9.4	18.8		22.1				
Green Ext Time (p_c), s		3.0			0.0	3.5		4.4				

**Intersection Summary**

HCM 6th Ctrl Delay	28.8
HCM 6th LOS	C

**Notes**

User approved volume balancing among the lanes for turning movement.  
 Unsignalized Delay for [SBR] is excluded from calculations of the approach delay and intersection delay.



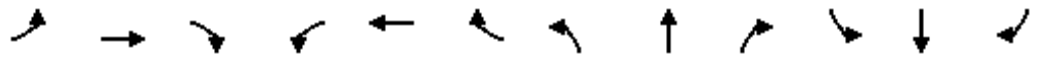



















HCM 6th Signalized Intersection Summary      2028 Opening Year Alter. C Project Conditions  
 12: US 101 SB On Ramp/US 101 SB Off Ramp & Old Redwood Highway      Timing Plan: P.M. Peak



Movement	EBL	EBT	EBR	WBL	WBT	WBR	NBL	NBT	NBR	SBL	SBT	SBR
Lane Configurations		↑↑	↗	↘	↑↑					↘	↕	
Traffic Volume (veh/h)	0	609	434	434	1166	0	0	0	0	200	0	147
Future Volume (veh/h)	0	609	434	434	1166	0	0	0	0	200	0	147
Initial Q (Qb), veh	0	0	0	0	0	0				0	0	0
Ped-Bike Adj(A_pbT)	1.00		0.98	1.00		1.00				1.00		1.00
Parking Bus, Adj	1.00	1.00	1.00	1.00	1.00	1.00				1.00	1.00	1.00
Work Zone On Approach		No			No						No	
Adj Sat Flow, veh/h/ln	0	1870	1870	1870	1870	0				1870	1870	1870
Adj Flow Rate, veh/h	0	648	462	488	1310	0				209	45	0
Peak Hour Factor	0.94	0.94	0.94	0.89	0.89	0.89				0.83	0.83	0.83
Percent Heavy Veh, %	0	2	2	2	2	0				2	2	2
Cap, veh/h	0	1424	625	461	2547	0				254	267	
Arrive On Green	0.00	0.40	0.40	0.26	0.72	0.00				0.14	0.14	0.00
Sat Flow, veh/h	0	3647	1560	1781	3647	0				1781	1870	0
Grp Volume(v), veh/h	0	648	462	488	1310	0				209	45	0
Grp Sat Flow(s),veh/h/ln	0	1777	1560	1781	1777	0				1781	1870	0
Q Serve(g_s), s	0.0	9.3	17.6	18.0	11.5	0.0				7.9	1.5	0.0
Cycle Q Clear(g_c), s	0.0	9.3	17.6	18.0	11.5	0.0				7.9	1.5	0.0
Prop In Lane	0.00		1.00	1.00		0.00				1.00		0.00
Lane Grp Cap(c), veh/h	0	1424	625	461	2547	0				254	267	
V/C Ratio(X)	0.00	0.46	0.74	1.06	0.51	0.00				0.82	0.17	
Avail Cap(c_a), veh/h	0	1424	625	461	2547	0				264	277	
HCM Platoon Ratio	1.00	1.00	1.00	1.00	1.00	1.00				1.00	1.00	1.00
Upstream Filter(I)	0.00	1.00	1.00	1.00	1.00	0.00				1.00	1.00	0.00
Uniform Delay (d), s/veh	0.0	15.3	17.8	25.8	4.4	0.0				29.0	26.2	0.0
Incr Delay (d2), s/veh	0.0	1.1	7.7	58.6	0.7	0.0				18.1	0.3	0.0
Initial Q Delay(d3),s/veh	0.0	0.0	0.0	0.0	0.0	0.0				0.0	0.0	0.0
%ile BackOfQ(50%),veh/ln	0.0	3.6	6.9	14.5	2.7	0.0				4.5	0.7	0.0
Unsig. Movement Delay, s/veh												
LnGrp Delay(d),s/veh	0.0	16.3	25.4	84.5	5.2	0.0				47.1	26.5	0.0
LnGrp LOS	A	B	C	F	A	A				D	C	
Approach Vol, veh/h		1110			1798						254	
Approach Delay, s/veh		20.1			26.7						43.5	
Approach LOS		C			C						D	
Timer - Assigned Phs		2			5	6		8				
Phs Duration (G+Y+Rc), s		55.0			22.0	33.0		14.6				
Change Period (Y+Rc), s		5.1			4.0	5.1		4.7				
Max Green Setting (Gmax), s		49.9			18.0	27.9		10.3				
Max Q Clear Time (g_c+I1), s		13.5			20.0	19.6		9.9				
Green Ext Time (p_c), s		12.5			0.0	3.8		0.0				
<b>Intersection Summary</b>												
HCM 6th Ctrl Delay			25.7									
HCM 6th LOS			C									
<b>Notes</b>												
User approved volume balancing among the lanes for turning movement.												
User approved ignoring U-Turning movement.												
Unsignalized Delay for [SBR] is excluded from calculations of the approach delay and intersection delay.												

HCM 6th Signalized Intersection Summary  
 1: Old Redwood Hwy & Shiloh Road





















2028 Opening Year Alter. C Project Conditions  
 Timing Plan: Saturday Midday Peak

												
Movement	EBL	EBT	EBR	WBL	WBT	WBR	NBL	NBT	NBR	SBL	SBT	SBR
Lane Configurations												
Traffic Volume (veh/h)	156	187	221	24	200	32	227	270	27	37	219	239
Future Volume (veh/h)	156	187	221	24	200	32	227	270	27	37	219	239
Initial Q (Qb), veh	0	0	0	0	0	0	0	0	0	0	0	0
Ped-Bike Adj(A_pbT)	1.00		0.97	1.00		1.00	1.00		0.98	1.00		0.97
Parking Bus, Adj	1.00	1.00	1.00	1.00	1.00	1.00	1.00	1.00	1.00	1.00	1.00	1.00
Work Zone On Approach		No			No			No			No	
Adj Sat Flow, veh/h/ln	1870	1870	1870	1870	1870	1870	1870	1870	1870	1870	1870	1870
Adj Flow Rate, veh/h	175	210	248	28	233	37	244	290	29	41	241	263
Peak Hour Factor	0.89	0.89	0.89	0.86	0.86	0.86	0.93	0.93	0.93	0.91	0.91	0.91
Percent Heavy Veh, %	2	2	2	2	2	2	2	2	2	2	2	2
Cap, veh/h	383	403	331	36	298	285	287	582	483	116	403	332
Arrive On Green	0.22	0.22	0.22	0.18	0.18	0.18	0.16	0.31	0.31	0.07	0.22	0.22
Sat Flow, veh/h	1781	1870	1536	200	1661	1585	1781	1870	1551	1781	1870	1540
Grp Volume(v), veh/h	175	210	248	261	0	37	244	290	29	41	241	263
Grp Sat Flow(s),veh/h/ln	1781	1870	1536	1860	0	1585	1781	1870	1551	1781	1870	1540
Q Serve(g_s), s	6.5	7.6	11.6	10.3	0.0	1.5	10.2	9.7	1.0	1.7	8.9	12.4
Cycle Q Clear(g_c), s	6.5	7.6	11.6	10.3	0.0	1.5	10.2	9.7	1.0	1.7	8.9	12.4
Prop In Lane	1.00		1.00	0.11		1.00	1.00		1.00	1.00		1.00
Lane Grp Cap(c), veh/h	383	403	331	334	0	285	287	582	483	116	403	332
V/C Ratio(X)	0.46	0.52	0.75	0.78	0.00	0.13	0.85	0.50	0.06	0.35	0.60	0.79
Avail Cap(c_a), veh/h	709	745	612	923	0	787	326	1062	881	128	855	704
HCM Platoon Ratio	1.00	1.00	1.00	1.00	1.00	1.00	1.00	1.00	1.00	1.00	1.00	1.00
Upstream Filter(I)	1.00	1.00	1.00	1.00	0.00	1.00	1.00	1.00	1.00	1.00	1.00	1.00
Uniform Delay (d), s/veh	26.1	26.6	28.1	30.0	0.0	26.4	31.2	21.5	18.5	34.2	27.0	28.4
Incr Delay (d2), s/veh	0.8	1.0	3.4	4.0	0.0	0.2	17.3	0.7	0.1	1.8	1.4	4.3
Initial Q Delay(d3),s/veh	0.0	0.0	0.0	0.0	0.0	0.0	0.0	0.0	0.0	0.0	0.0	0.0
%ile BackOfQ(50%),veh/ln	2.7	3.3	4.2	4.7	0.0	0.5	5.4	3.9	0.3	0.8	3.9	4.6
Unsig. Movement Delay, s/veh												
LnGrp Delay(d),s/veh	27.0	27.6	31.5	34.0	0.0	26.6	48.5	22.1	18.6	36.1	28.5	32.7
LnGrp LOS	C	C	C	C	A	C	D	C	B	D	C	C
Approach Vol, veh/h		633			298			563			545	
Approach Delay, s/veh		29.0			33.1			33.4			31.1	
Approach LOS		C			C			C			C	
Timer - Assigned Phs		2	3	4		6	7	8				
Phs Duration (G+Y+Rc), s		21.0	16.3	21.0		18.2	9.0	28.3				
Change Period (Y+Rc), s		4.5	4.0	4.5		4.5	4.0	4.5				
Max Green Setting (Gmax), s		30.5	14.0	35.0		38.0	5.5	43.5				
Max Q Clear Time (g_c+I1), s		13.6	12.2	14.4		12.3	3.7	11.7				
Green Ext Time (p_c), s		2.3	0.1	2.1		1.5	0.0	1.7				
<b>Intersection Summary</b>												
HCM 6th Ctrl Delay			31.4									
HCM 6th LOS			C									

HCM 6th Signalized Intersection Summary  
2: Shiloh Road & Hembree Ln

2028 Opening Year Alter. C Project Conditions

Timing Plan: Saturday Midday Peak

												
Movement	EBL	EBT	EBR	WBL	WBT	WBR	NBL	NBT	NBR	SBL	SBT	SBR
Lane Configurations												
Traffic Volume (veh/h)	708	487	44	24	423	185	65	11	15	182	11	666
Future Volume (veh/h)	708	487	44	24	423	185	65	11	15	182	11	666
Initial Q (Qb), veh	0	0	0	0	0	0	0	0	0	0	0	0
Ped-Bike Adj(A_pbT)	1.00		1.00	1.00		1.00	1.00		1.00	1.00		1.00
Parking Bus, Adj	1.00	1.00	1.00	1.00	1.00	1.00	1.00	1.00	1.00	1.00	1.00	1.00
Work Zone On Approach		No			No			No			No	
Adj Sat Flow, veh/h/ln	1870	1870	1870	1870	1870	1870	1870	1870	1870	1870	1870	1870
Adj Flow Rate, veh/h	753	518	44	24	441	193	65	11	15	200	11	732
Peak Hour Factor	0.94	0.94	1.00	1.00	0.96	0.96	1.00	1.00	1.00	0.91	1.00	0.91
Percent Heavy Veh, %	2	2	2	2	2	2	2	2	2	2	2	2
Cap, veh/h	869	836	71	49	646	280	113	46	62	272	15	653
Arrive On Green	0.25	0.49	0.49	0.03	0.27	0.27	0.06	0.06	0.06	0.16	0.16	0.16
Sat Flow, veh/h	3456	1700	144	1781	2412	1046	1781	717	978	1693	93	1585
Grp Volume(v), veh/h	753	0	562	24	324	310	65	0	26	211	0	732
Grp Sat Flow(s),veh/h/ln	1728	0	1844	1781	1777	1681	1781	0	1694	1786	0	1585
Q Serve(g_s), s	13.0	0.0	13.9	0.8	10.2	10.3	2.2	0.0	0.9	7.0	0.0	10.0
Cycle Q Clear(g_c), s	13.0	0.0	13.9	0.8	10.2	10.3	2.2	0.0	0.9	7.0	0.0	10.0
Prop In Lane	1.00		0.08	1.00		0.62	1.00		0.58	0.95		1.00
Lane Grp Cap(c), veh/h	869	0	907	49	476	450	113	0	108	286	0	653
V/C Ratio(X)	0.87	0.00	0.62	0.49	0.68	0.69	0.57	0.00	0.24	0.74	0.00	1.12
Avail Cap(c_a), veh/h	942	0	1568	157	1183	1119	157	0	149	286	0	653
HCM Platoon Ratio	1.00	1.00	1.00	1.00	1.00	1.00	1.00	1.00	1.00	1.00	1.00	1.00
Upstream Filter(I)	1.00	0.00	1.00	1.00	1.00	1.00	1.00	0.00	1.00	1.00	0.00	1.00
Uniform Delay (d), s/veh	22.3	0.0	11.6	29.9	20.4	20.5	28.4	0.0	27.8	24.9	0.0	18.3
Incr Delay (d2), s/veh	8.1	0.0	0.7	7.6	1.7	1.9	4.5	0.0	1.1	9.5	0.0	73.4
Initial Q Delay(d3),s/veh	0.0	0.0	0.0	0.0	0.0	0.0	0.0	0.0	0.0	0.0	0.0	0.0
%ile BackOfQ(50%),veh/ln	5.6	0.0	4.6	0.4	3.9	3.8	1.0	0.0	0.4	3.5	0.0	21.4
Unsig. Movement Delay, s/veh												
LnGrp Delay(d),s/veh	30.4	0.0	12.3	37.5	22.2	22.4	32.9	0.0	28.9	34.5	0.0	91.7
LnGrp LOS	C	A	B	D	C	C	C	A	C	C	A	F
Approach Vol, veh/h		1315			658			91				943
Approach Delay, s/veh		22.7			22.8			31.7				78.9
Approach LOS		C			C			C				E
Timer - Assigned Phs	1	2		4	5	6		8				
Phs Duration (G+Y+Rc), s	5.7	34.7		14.0	19.7	20.7		8.0				
Change Period (Y+Rc), s	4.0	4.0		4.0	4.0	4.0		4.0				
Max Green Setting (Gmax), s	5.5	53.0		10.0	17.0	41.5		5.5				
Max Q Clear Time (g_c+I1), s	2.8	15.9		12.0	15.0	12.3		4.2				
Green Ext Time (p_c), s	0.0	3.8		0.0	0.7	4.0		0.0				
<b>Intersection Summary</b>												
HCM 6th Ctrl Delay				40.6								
HCM 6th LOS				D								

HCM 6th Signalized Intersection Summary  
 3: US 101 NB Off-Ramp & Shiloh Road

2028 Opening Year Alter. C Project Conditions

Timing Plan: Saturday Midday Peak

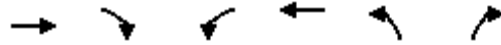

Movement	EBT	EBR	WBL	WBT	NBL	NBR
Lane Configurations	↑↑			↑	↘	↗
Traffic Volume (veh/h)	493	0	0	869	401	735
Future Volume (veh/h)	493	0	0	869	401	735
Initial Q (Qb), veh	0	0	0	0	0	0
Ped-Bike Adj(A_pbT)		1.00	1.00		1.00	1.00
Parking Bus, Adj	1.00	1.00	1.00	1.00	1.00	1.00
Work Zone On Approach	No			No	No	
Adj Sat Flow, veh/h/ln	1870	0	0	1870	1870	1870
Adj Flow Rate, veh/h	542	0	0	976	422	774
Peak Hour Factor	0.91	0.91	0.89	0.89	0.95	0.95
Percent Heavy Veh, %	2	0	0	2	2	2
Cap, veh/h	1817	0	0	956	618	968
Arrive On Green	0.51	0.00	0.00	0.51	0.35	0.35
Sat Flow, veh/h	3741	0	0	1870	1781	2790
Grp Volume(v), veh/h	542	0	0	976	422	774
Grp Sat Flow(s),veh/h/ln	1777	0	0	1870	1781	1395
Q Serve(g_s), s	5.6	0.0	0.0	32.5	12.9	15.9
Cycle Q Clear(g_c), s	5.6	0.0	0.0	32.5	12.9	15.9
Prop In Lane		0.00	0.00		1.00	1.00
Lane Grp Cap(c), veh/h	1817	0	0	956	618	968
V/C Ratio(X)	0.30	0.00	0.00	1.02	0.68	0.80
Avail Cap(c_a), veh/h	1817	0	0	956	855	1339
HCM Platoon Ratio	1.00	1.00	1.00	1.00	1.00	1.00
Upstream Filter(I)	1.00	0.00	0.00	1.00	1.00	1.00
Uniform Delay (d), s/veh	9.0	0.0	0.0	15.5	17.8	18.8
Incr Delay (d2), s/veh	0.1	0.0	0.0	34.4	1.3	2.4
Initial Q Delay(d3),s/veh	0.0	0.0	0.0	0.0	0.0	0.0
%ile BackOfQ(50%),veh/ln	1.7	0.0	0.0	19.5	5.0	5.0
Unsig. Movement Delay, s/veh						
LnGrp Delay(d),s/veh	9.0	0.0	0.0	49.9	19.1	21.2
LnGrp LOS	A	A	A	F	B	C
Approach Vol, veh/h	542			976	1196	
Approach Delay, s/veh	9.0			49.9	20.5	
Approach LOS	A			D	C	
Timer - Assigned Phs		2			6	8
Phs Duration (G+Y+Rc), s		37.0			37.0	26.6
Change Period (Y+Rc), s		4.5			4.5	4.5
Max Green Setting (Gmax), s		32.5			32.5	30.5
Max Q Clear Time (g_c+I1), s		7.6			34.5	17.9
Green Ext Time (p_c), s		3.5			0.0	4.1
<b>Intersection Summary</b>						
HCM 6th Ctrl Delay			28.8			
HCM 6th LOS			C			

# HCM Signalized Intersection Capacity Analysis 2028 Opening Year Alter. C Project Conditions

## 4: Shiloh Road & US 101 SB Off-Ramp

Timing Plan: Saturday Midday Peak



Movement	EBL	EBT	WBT	WBR	SBL	SBR
Lane Configurations		↑	↑		↙	↗
Traffic Volume (vph)	0	326	610	0	255	174
Future Volume (vph)	0	326	610	0	255	174
Ideal Flow (vphpl)	1900	1900	1900	1900	1900	1900
Total Lost time (s)		4.5	4.5		4.5	4.5
Lane Util. Factor		1.00	1.00		1.00	1.00
Frbp, ped/bikes		1.00	1.00		1.00	1.00
Flpb, ped/bikes		1.00	1.00		1.00	1.00
Frt		1.00	1.00		1.00	0.85
Flt Protected		1.00	1.00		0.95	1.00
Satd. Flow (prot)		1863	1863		1770	1583
Flt Permitted		1.00	1.00		0.95	1.00
Satd. Flow (perm)		1863	1863		1770	1583
Peak-hour factor, PHF	0.96	0.96	0.96	0.96	0.68	0.68
Adj. Flow (vph)	0	340	635	0	375	256
RTOR Reduction (vph)	0	0	0	0	0	165
Lane Group Flow (vph)	0	340	635	0	375	91
Confl. Bikes (#/hr)				2		
Turn Type		NA	NA		Perm	Perm
Protected Phases		2	6			
Permitted Phases					4	4
Actuated Green, G (s)		21.3	21.3		16.7	16.7
Effective Green, g (s)		21.3	21.3		16.7	16.7
Actuated g/C Ratio		0.45	0.45		0.36	0.36
Clearance Time (s)		4.5	4.5		4.5	4.5
Vehicle Extension (s)		3.0	3.0		3.0	3.0
Lane Grp Cap (vph)		844	844		628	562
v/s Ratio Prot		0.18	c0.34			
v/s Ratio Perm					c0.21	0.06
v/c Ratio		0.40	0.75		0.60	0.16
Uniform Delay, d1		8.6	10.7		12.4	10.4
Progression Factor		1.00	1.00		1.00	1.00
Incremental Delay, d2		0.3	3.8		1.5	0.1
Delay (s)		8.9	14.5		13.9	10.5
Level of Service		A	B		B	B
Approach Delay (s)		8.9	14.5		12.5	
Approach LOS		A	B		B	
<b>Intersection Summary</b>						
HCM 2000 Control Delay			12.5		HCM 2000 Level of Service	B
HCM 2000 Volume to Capacity ratio			0.68			
Actuated Cycle Length (s)			47.0		Sum of lost time (s)	9.0
Intersection Capacity Utilization			110.9%		ICU Level of Service	H
Analysis Period (min)			15			
c Critical Lane Group						



Intersection						
Int Delay, s/veh	2.2					
Movement	EBT	EBR	WBL	WBT	NBL	NBR
Lane Configurations	↑↑		↖	↑	↖	↖
Traffic Vol, veh/h	620	23	92	686	18	89
Future Vol, veh/h	620	23	92	686	18	89
Conflicting Peds, #/hr	0	0	0	0	1	0
Sign Control	Free	Free	Free	Free	Stop	Stop
RT Channelized	-	None	-	None	-	None
Storage Length	-	-	68	-	0	0
Veh in Median Storage, #	0	-	-	0	0	-
Grade, %	0	-	-	0	0	-
Peak Hour Factor	92	92	87	87	78	78
Heavy Vehicles, %	2	2	2	2	2	2
Mvmt Flow	674	25	106	789	23	114



















Major/Minor	Major1	Major2	Minor1		
Conflicting Flow All	0	0	699	0	1689 350
Stage 1	-	-	-	-	687 -
Stage 2	-	-	-	-	1002 -
Critical Hdwy	-	-	4.13	-	6.63 6.93
Critical Hdwy Stg 1	-	-	-	-	5.83 -
Critical Hdwy Stg 2	-	-	-	-	5.43 -
Follow-up Hdwy	-	-	2.219	-	3.519 3.319
Pot Cap-1 Maneuver	-	-	896	-	93 647
Stage 1	-	-	-	-	462 -
Stage 2	-	-	-	-	354 -
Platoon blocked, %	-	-	-	-	-
Mov Cap-1 Maneuver	-	-	896	-	82 647
Mov Cap-2 Maneuver	-	-	-	-	82 -
Stage 1	-	-	-	-	462 -
Stage 2	-	-	-	-	312 -

Approach	EB	WB	NB
HCM Control Delay, s	0	1.1	20.8
HCM LOS			C

Minor Lane/Major Mvmt	NBLn1	NBLn2	EBT	EBR	WBL	WBT
Capacity (veh/h)	82	647	-	-	896	-
HCM Lane V/C Ratio	0.281	0.176	-	-	0.118	-
HCM Control Delay (s)	65.3	11.8	-	-	9.6	-
HCM Lane LOS	F	B	-	-	A	-
HCM 95th %tile Q(veh)	1	0.6	-	-	0.4	-

HCM Signalized Intersection Capacity Analysis 2028 Opening Year Alter. C Project Conditions  
 6: Conde Lane & Shiloh Road

Timing Plan: Saturday Midday Peak

												
Movement	EBL	EBT	EBR	WBL	WBT	WBR	NBL	NBT	NBR	SBL	SBT	SBR
Lane Configurations												
Traffic Volume (vph)	33	410	1	10	458	232	1	0	7	224	0	32
Future Volume (vph)	33	410	1	10	458	232	1	0	7	224	0	32
Ideal Flow (vphp)	1900	1900	1900	1900	1900	1900	1900	1900	1900	1900	1900	1900
Total Lost time (s)	4.5	4.5		4.5	4.5			4.5			4.5	4.5
Lane Util. Factor	1.00	0.95		1.00	0.95			1.00			1.00	1.00
Frbp, ped/bikes	1.00	1.00		1.00	0.99			1.00			1.00	1.00
Flpb, ped/bikes	1.00	1.00		1.00	1.00			1.00			1.00	1.00
Frt	1.00	1.00		1.00	0.95			0.88			1.00	0.85
Flt Protected	0.95	1.00		0.95	1.00			0.99			0.95	1.00
Satd. Flow (prot)	1770	3538		1770	3336			1636			1770	1583
Flt Permitted	0.95	1.00		0.95	1.00			0.99			0.95	1.00
Satd. Flow (perm)	1770	3538		1770	3336			1636			1770	1583
Peak-hour factor, PHF	0.96	0.96	0.96	0.91	0.91	0.91	0.58	0.58	0.58	0.78	0.78	0.78
Adj. Flow (vph)	34	427	1	11	503	255	2	0	12	287	0	41
RTOR Reduction (vph)	0	0	0	0	59	0	0	14	0	0	0	0
Lane Group Flow (vph)	34	428	0	11	699	0	0	0	0	0	287	41
Confl. Bikes (#/hr)						2						
Turn Type	Prot	NA		Prot	NA		Split	NA		Split	NA	custom
Protected Phases	5	2		1	6		7	7		4	4	
Permitted Phases												6
Actuated Green, G (s)	2.4	19.3		1.0	17.9			1.2			12.4	17.9
Effective Green, g (s)	2.4	19.3		1.0	17.9			1.2			12.4	17.9
Actuated g/C Ratio	0.05	0.37		0.02	0.34			0.02			0.24	0.34
Clearance Time (s)	4.5	4.5		4.5	4.5			4.5			4.5	4.5
Vehicle Extension (s)	3.0	3.0		3.0	3.0			3.0			3.0	3.0
Lane Grp Cap (vph)	81	1315		34	1150			37			422	545
v/s Ratio Prot	c0.02	0.12		0.01	c0.21			c0.00			c0.16	
v/s Ratio Perm												0.03
v/c Ratio	0.42	0.33		0.32	0.61			0.01			0.68	0.08
Uniform Delay, d1	24.1	11.6		25.1	14.1			24.8			17.9	11.4
Progression Factor	1.00	1.00		1.00	1.00			1.00			1.00	1.00
Incremental Delay, d2	3.5	0.1		5.5	0.9			0.1			4.5	0.1
Delay (s)	27.6	11.8		30.6	15.0			24.9			22.4	11.5
Level of Service	C	B		C	B			C			C	B
Approach Delay (s)		13.0			15.2			24.9			21.1	
Approach LOS		B			B			C			C	
<b>Intersection Summary</b>												
HCM 2000 Control Delay			15.9			HCM 2000 Level of Service				B		
HCM 2000 Volume to Capacity ratio			0.60									
Actuated Cycle Length (s)			51.9			Sum of lost time (s)			18.0			
Intersection Capacity Utilization			54.0%			ICU Level of Service				A		
Analysis Period (min)			15									
c Critical Lane Group												

HCM 6th TWSC  
7: Driveway 1/Gridley Drive & Shiloh Road

2028 Opening Year Alter. C Project Conditions  
Timing Plan: Saturday Midday Peak

Intersection												
Int Delay, s/veh	4.3											
Movement	EBL	EBT	EBR	WBL	WBT	WBR	NBL	NBT	NBR	SBL	SBT	SBR
Lane Configurations		↕			↕		↕	↕			↕	
Traffic Vol, veh/h	23	121	112	8	105	0	133	0	9	0	0	20
Future Vol, veh/h	23	121	112	8	105	0	133	0	9	0	0	20
Conflicting Peds, #/hr	1	0	0	0	0	0	0	0	0	0	0	0
Sign Control	Free	Free	Free	Free	Free	Free	Stop	Stop	Stop	Stop	Stop	Stop
RT Channelized	-	-	None	-	-	None	-	-	None	-	-	None
Storage Length	-	-	-	-	-	-	0	-	-	-	-	-
Veh in Median Storage, #	-	0	-	-	0	-	-	0	-	-	0	-
Grade, %	-	0	-	-	0	-	-	0	-	-	0	-
Peak Hour Factor	93	93	93	88	88	88	100	100	100	56	56	56
Heavy Vehicles, %	2	2	2	2	2	2	2	2	2	2	2	2
Mvmt Flow	25	130	120	9	119	0	133	0	9	0	0	36

Major/Minor	Major1			Major2			Minor1			Minor2		
Conflicting Flow All	120	0	0	250	0	0	395	378	190	383	438	120
Stage 1	-	-	-	-	-	-	240	240	-	138	138	-
Stage 2	-	-	-	-	-	-	155	138	-	245	300	-
Critical Hdwy	4.12	-	-	4.12	-	-	7.12	6.52	6.22	7.12	6.52	6.22
Critical Hdwy Stg 1	-	-	-	-	-	-	6.12	5.52	-	6.12	5.52	-
Critical Hdwy Stg 2	-	-	-	-	-	-	6.12	5.52	-	6.12	5.52	-
Follow-up Hdwy	2.218	-	-	2.218	-	-	3.518	4.018	3.318	3.518	4.018	3.318
Pot Cap-1 Maneuver	1468	-	-	1316	-	-	565	554	852	575	512	931
Stage 1	-	-	-	-	-	-	763	707	-	865	782	-
Stage 2	-	-	-	-	-	-	847	782	-	759	666	-
Platoon blocked, %		-	-		-	-						
Mov Cap-1 Maneuver	1467	-	-	1316	-	-	532	538	852	557	498	930
Mov Cap-2 Maneuver	-	-	-	-	-	-	532	538	-	557	498	-
Stage 1	-	-	-	-	-	-	748	693	-	847	776	-
Stage 2	-	-	-	-	-	-	809	776	-	736	653	-

Approach	EB			WB			NB			SB		
HCM Control Delay, s	0.7			0.5			13.7			9		
HCM LOS							B			A		

Minor Lane/Major Mvmt	NBLn1	NBLn2	EBL	EBT	EBR	WBL	WBT	WBR	SBLn1
Capacity (veh/h)	532	852	1467	-	-	1316	-	-	930
HCM Lane V/C Ratio	0.25	0.011	0.017	-	-	0.007	-	-	0.038
HCM Control Delay (s)	14	9.3	7.5	0	-	7.8	0	-	9
HCM Lane LOS	B	A	A	A	-	A	A	-	A
HCM 95th %tile Q(veh)	1	0	0.1	-	-	0	-	-	0.1

HCM 6th TWSC  
8: Old Redwood Hwy & Driveway 2

2028 Opening Year Alter. C Project Conditions  
Timing Plan: Saturday Midday Peak

Intersection												
Int Delay, s/veh	1.1											
Movement	EBL	EBT	EBR	WBL	WBT	WBR	NBL	NBT	NBR	SBL	SBT	SBR
Lane Configurations		↕		↕	↕			↕		↕	↕	
Traffic Vol, veh/h	1	0	2	19	0	31	1	459	17	27	389	5
Future Vol, veh/h	1	0	2	19	0	31	1	459	17	27	389	5
Conflicting Peds, #/hr	0	0	0	0	0	0	1	0	4	4	0	1
Sign Control	Stop	Stop	Stop	Stop	Stop	Stop	Free	Free	Free	Free	Free	Free
RT Channelized	-	-	None	-	-	None	-	-	None	-	-	None
Storage Length	-	-	-	0	-	-	-	-	-	50	-	-
Veh in Median Storage, #	-	0	-	-	0	-	-	0	-	-	0	-
Grade, %	-	0	-	-	0	-	-	0	-	-	0	-
Peak Hour Factor	38	38	38	100	100	100	94	94	94	93	93	93
Heavy Vehicles, %	2	2	2	2	2	2	2	2	2	2	2	2
Mvmt Flow	3	0	5	19	0	31	1	488	18	29	418	5

Major/Minor	Minor2		Minor1		Major1		Major2					
Conflicting Flow All	995	992	422	984	985	501	424	0	0	510	0	0
Stage 1	480	480	-	503	503	-	-	-	-	-	-	-
Stage 2	515	512	-	481	482	-	-	-	-	-	-	-
Critical Hdwy	7.12	6.52	6.22	7.12	6.52	6.22	4.12	-	-	4.12	-	-
Critical Hdwy Stg 1	6.12	5.52	-	6.12	5.52	-	-	-	-	-	-	-
Critical Hdwy Stg 2	6.12	5.52	-	6.12	5.52	-	-	-	-	-	-	-
Follow-up Hdwy	3.518	4.018	3.318	3.518	4.018	3.318	2.218	-	-	2.218	-	-
Pot Cap-1 Maneuver	224	246	632	228	248	570	1135	-	-	1055	-	-
Stage 1	567	554	-	551	541	-	-	-	-	-	-	-
Stage 2	543	536	-	566	553	-	-	-	-	-	-	-
Platoon blocked, %								-	-	-	-	-
Mov Cap-1 Maneuver	207	238	631	220	240	568	1134	-	-	1051	-	-
Mov Cap-2 Maneuver	207	238	-	220	240	-	-	-	-	-	-	-
Stage 1	566	538	-	548	538	-	-	-	-	-	-	-
Stage 2	513	533	-	546	537	-	-	-	-	-	-	-

Approach	EB		WB		NB		SB	
HCM Control Delay, s	14.8		16		0		0.5	
HCM LOS	B		C					

Minor Lane/Major Mvmt	NBL	NBT	NBR	EBLn1	WBLn1	WBLn2	SBL	SBT	SBR
Capacity (veh/h)	1134	-	-	375	220	568	1051	-	-
HCM Lane V/C Ratio	0.001	-	-	0.021	0.086	0.055	0.028	-	-
HCM Control Delay (s)	8.2	0	-	14.8	22.9	11.7	8.5	-	-
HCM Lane LOS	A	A	-	B	C	B	A	-	-
HCM 95th %tile Q(veh)	0	-	-	0.1	0.3	0.2	0.1	-	-

Intersection						
Int Delay, s/veh	0					
Movement	EBT	EBR	WBL	WBT	NBL	NBR
Lane Configurations	↔			↔	↔	↔
Traffic Vol, veh/h	114	0	0	106	0	0
Future Vol, veh/h	114	0	0	106	0	0
Conflicting Peds, #/hr	0	1	0	0	0	0
Sign Control	Free	Free	Free	Free	Stop	Stop
RT Channelized	-	None	-	None	-	None
Storage Length	-	-	-	-	0	0
Veh in Median Storage, #	0	-	-	0	0	-
Grade, %	0	-	-	0	0	-
Peak Hour Factor	88	88	80	80	100	100
Heavy Vehicles, %	2	2	2	2	2	2
Mvmt Flow	130	0	0	133	0	0

Major/Minor	Major1	Major2	Minor1		
Conflicting Flow All	0	0	131	0	264
Stage 1	-	-	-	-	131
Stage 2	-	-	-	-	133
Critical Hdwy	-	-	4.12	-	6.42
Critical Hdwy Stg 1	-	-	-	-	5.42
Critical Hdwy Stg 2	-	-	-	-	5.42
Follow-up Hdwy	-	-	2.218	-	3.518
Pot Cap-1 Maneuver	-	-	1454	-	725
Stage 1	-	-	-	-	895
Stage 2	-	-	-	-	893
Platoon blocked, %	-	-	-	-	-
Mov Cap-1 Maneuver	-	-	1453	-	724
Mov Cap-2 Maneuver	-	-	-	-	724
Stage 1	-	-	-	-	894
Stage 2	-	-	-	-	893

Approach	EB	WB	NB
HCM Control Delay, s	0	0	0
HCM LOS			A

Minor Lane/Major Mvmt	NBLn1	NBLn2	EBT	EBR	WBL	WBT
Capacity (veh/h)	-	-	-	-	1453	-
HCM Lane V/C Ratio	-	-	-	-	-	-
HCM Control Delay (s)	0	0	-	-	0	-
HCM Lane LOS	A	A	-	-	A	-
HCM 95th %tile Q(veh)	-	-	-	-	0	-

HCM 6th Signalized Intersection Summary      2028 Opening Year Alter. C Project Conditions  
 10: US 101 NB Off Ramp/Lakewood Drive & Old Redwood Highway      Timing Plan: Saturday Midday Peak

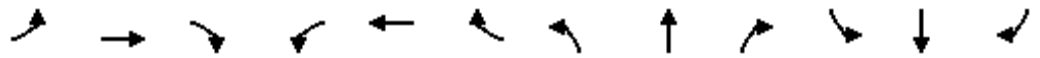

Movement	EBL	EBT	EBR	WBL	WBT	WBR	NBL	NBT	NBR	SBL	SBT	SBR
Lane Configurations	↔↔	↑			↔↔		↔	↔↔		↔↔		↔
Traffic Volume (veh/h)	287	330	0	0	521	276	320	303	142	244	0	700
Future Volume (veh/h)	287	330	0	0	521	276	320	303	142	244	0	700
Initial Q (Qb), veh	0	0	0	0	0	0	0	0	0	0	0	0
Ped-Bike Adj(A_pbT)	1.00		1.00	1.00		0.99	1.00		1.00	1.00		1.00
Parking Bus, Adj	1.00	1.00	1.00	1.00	1.00	1.00	1.00	1.00	1.00	1.00	1.00	1.00
Work Zone On Approach		No			No			No			No	
Adj Sat Flow, veh/h/ln	1870	1870	0	0	1870	1870	1870	1870	1870	1870	0	1870
Adj Flow Rate, veh/h	302	347	0	0	585	310	260	402	145	277	0	0
Peak Hour Factor	0.95	0.95	0.95	0.89	0.89	0.89	0.98	0.98	0.98	0.88	0.88	0.88
Percent Heavy Veh, %	2	2	0	0	2	2	2	2	2	2	0	2
Cap, veh/h	397	1173	0	0	989	523	418	618	220	0	0	0
Arrive On Green	0.11	0.63	0.00	0.00	0.44	0.44	0.23	0.23	0.23	0.00	0.00	0.00
Sat Flow, veh/h	3456	1870	0	0	2325	1182	1781	2633	938		0	
Grp Volume(v), veh/h	302	347	0	0	466	429	260	284	263		0.0	
Grp Sat Flow(s),veh/h/ln	1728	1870	0	0	1777	1637	1781	1870	1700			
Q Serve(g_s), s	5.5	5.5	0.0	0.0	12.9	12.9	8.5	8.9	9.1			
Cycle Q Clear(g_c), s	5.5	5.5	0.0	0.0	12.9	12.9	8.5	8.9	9.1			
Prop In Lane	1.00		0.00	0.00		0.72	1.00		0.55			
Lane Grp Cap(c), veh/h	397	1173	0	0	787	725	418	439	399			
V/C Ratio(X)	0.76	0.30	0.00	0.00	0.59	0.59	0.62	0.65	0.66			
Avail Cap(c_a), veh/h	398	1173	0	0	787	725	799	839	763			
HCM Platoon Ratio	1.00	1.00	1.00	1.00	1.00	1.00	1.00	1.00	1.00			
Upstream Filter(I)	1.00	1.00	0.00	0.00	1.00	1.00	1.00	1.00	1.00			
Uniform Delay (d), s/veh	27.9	5.6	0.0	0.0	13.7	13.7	22.3	22.5	22.5			
Incr Delay (d2), s/veh	8.3	0.6	0.0	0.0	3.3	3.5	1.5	1.6	1.9			
Initial Q Delay(d3),s/veh	0.0	0.0	0.0	0.0	0.0	0.0	0.0	0.0	0.0			
%ile BackOfQ(50%),veh/ln	2.6	1.8	0.0	0.0	5.1	4.8	3.5	3.9	3.6			
Unsig. Movement Delay, s/veh												
LnGrp Delay(d),s/veh	36.2	6.2	0.0	0.0	16.9	17.2	23.8	24.1	24.4			
LnGrp LOS	D	A	A	A	B	B	C	C	C			
Approach Vol, veh/h		649			895			807				
Approach Delay, s/veh		20.2			17.1			24.1				
Approach LOS		C			B			C				
Timer - Assigned Phs		2			5	6		8				
Phs Duration (G+Y+Rc), s		45.3			12.0	33.3		19.8				
Change Period (Y+Rc), s		4.5			4.5	4.5		4.5				
Max Green Setting (Gmax), s		40.8			7.5	28.8		29.2				
Max Q Clear Time (g_c+I1), s		7.5			7.5	14.9		11.1				
Green Ext Time (p_c), s		2.1			0.0	4.9		4.0				

**Intersection Summary**

HCM 6th Ctrl Delay	20.3
HCM 6th LOS	C

**Notes**

User approved volume balancing among the lanes for turning movement.  
 Unsignalized Delay for [SBR] is excluded from calculations of the approach delay and intersection delay.

HCM 6th Signalized Intersection Summary 2028 Opening Year Alter. C Project Conditions  
 12: US 101 SB On Ramp/US 101 SB Off Ramp & Old Redwood Highway Timing Plan: Saturday Midday Peak

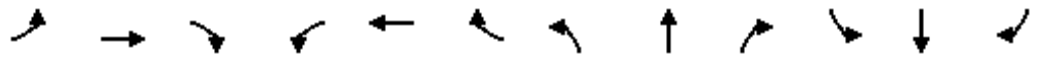

Movement	EBL	EBT	EBR	WBL	WBT	WBR	NBL	NBT	NBR	SBL	SBT	SBR
Lane Configurations		↑↑	↗	↖	↑↑					↘	↕	
Traffic Volume (veh/h)	0	550	419	487	818	0	0	0	0	168	1	87
Future Volume (veh/h)	0	550	419	487	818	0	0	0	0	168	1	87
Initial Q (Qb), veh	0	0	0	0	0	0				0	0	0
Ped-Bike Adj(A_pbT)	1.00		0.98	1.00		1.00				1.00		1.00
Parking Bus, Adj	1.00	1.00	1.00	1.00	1.00	1.00				1.00	1.00	1.00
Work Zone On Approach		No			No						No	
Adj Sat Flow, veh/h/ln	0	1870	1870	1870	1870	0				1870	1870	1870
Adj Flow Rate, veh/h	0	567	432	507	852	0				178	79	0
Peak Hour Factor	0.97	0.97	0.97	0.96	0.96	0.96				0.72	0.72	0.72
Percent Heavy Veh, %	0	2	2	2	2	0				2	2	2
Cap, veh/h	0	1417	620	473	2589	0				254	266	
Arrive On Green	0.00	0.40	0.40	0.27	0.73	0.00				0.14	0.14	0.00
Sat Flow, veh/h	0	3647	1555	1781	3647	0				1781	1870	0
Grp Volume(v), veh/h	0	567	432	507	852	0				178	79	0
Grp Sat Flow(s),veh/h/ln	0	1777	1555	1781	1777	0				1781	1870	0
Q Serve(g_s), s	0.0	8.0	16.1	18.5	6.0	0.0				6.6	2.6	0.0
Cycle Q Clear(g_c), s	0.0	8.0	16.1	18.5	6.0	0.0				6.6	2.6	0.0
Prop In Lane	0.00		1.00	1.00		0.00				1.00		0.00
Lane Grp Cap(c), veh/h	0	1417	620	473	2589	0				254	266	
V/C Ratio(X)	0.00	0.40	0.70	1.07	0.33	0.00				0.70	0.30	
Avail Cap(c_a), veh/h	0	1417	620	473	2589	0				261	274	
HCM Platoon Ratio	1.00	1.00	1.00	1.00	1.00	1.00				1.00	1.00	1.00
Upstream Filter(I)	0.00	1.00	1.00	1.00	1.00	0.00				1.00	1.00	0.00
Uniform Delay (d), s/veh	0.0	15.0	17.5	25.6	3.4	0.0				28.5	26.8	0.0
Incr Delay (d2), s/veh	0.0	0.8	6.4	62.3	0.3	0.0				7.9	0.6	0.0
Initial Q Delay(d3),s/veh	0.0	0.0	0.0	0.0	0.0	0.0				0.0	0.0	0.0
%ile BackOfQ(50%),veh/ln	0.0	3.0	6.2	15.3	1.3	0.0				3.3	1.2	0.0
Unsig. Movement Delay, s/veh												
LnGrp Delay(d),s/veh	0.0	15.8	23.8	87.9	3.7	0.0				36.4	27.4	0.0
LnGrp LOS	A	B	C	F	A	A				D	C	
Approach Vol, veh/h		999			1359						257	
Approach Delay, s/veh		19.3			35.1						33.6	
Approach LOS		B			D						C	
Timer - Assigned Phs		2			5	6		8				
Phs Duration (G+Y+Rc), s		55.3			23.0	32.3		14.4				
Change Period (Y+Rc), s		4.5			4.5	4.5		4.5				
Max Green Setting (Gmax), s		50.8			18.5	27.8		10.2				
Max Q Clear Time (g_c+I1), s		8.0			20.5	18.1		8.6				
Green Ext Time (p_c), s		7.0			0.0	3.8		0.1				

Intersection Summary		
HCM 6th Ctrl Delay		28.9
HCM 6th LOS		C

**Notes**  
 User approved volume balancing among the lanes for turning movement.  
 User approved ignoring U-Turning movement.  
 Unsignalized Delay for [SBR] is excluded from calculations of the approach delay and intersection delay.

Queues  
1: Old Redwood Hwy & Shiloh Road

2028 Opening Year Alter. C Project Conditions  
Timing Plan: A.M. PEAK



Lane Group	EBL	EBT	EBR	WBT	WBR	NBL	NBT	NBR	SBL	SBT	SBR
Lane Group Flow (vph)	169	217	135	138	20	110	154	42	26	312	245
v/c Ratio	0.44	0.54	0.30	0.45	0.06	0.42	0.22	0.06	0.17	0.62	0.48
Control Delay	33.8	35.5	8.1	38.8	0.3	40.9	19.0	1.5	44.4	32.8	16.1
Queue Delay	0.0	0.0	0.0	0.0	0.0	0.0	0.0	0.0	0.0	0.0	0.0
Total Delay	33.8	35.5	8.1	38.8	0.3	40.9	19.0	1.5	44.4	32.8	16.1
Queue Length 50th (ft)	69	91	0	59	0	47	40	0	12	127	41
Queue Length 95th (ft)	144	181	35	146	0	128	119	7	44	251	117
Internal Link Dist (ft)		1709		528			668			695	
Turn Bay Length (ft)	375		140		50	200		98	130		93
Base Capacity (vph)	801	843	790	1040	939	381	1182	1033	157	968	868
Starvation Cap Reductn	0	0	0	0	0	0	0	0	0	0	0
Spillback Cap Reductn	0	0	0	0	0	0	0	0	0	0	0
Storage Cap Reductn	0	0	0	0	0	0	0	0	0	0	0
Reduced v/c Ratio	0.21	0.26	0.17	0.13	0.02	0.29	0.13	0.04	0.17	0.32	0.28

Intersection Summary



Queues  
2: Shiloh Road & Hembree Ln

2028 Opening Year Alter. C Project Conditions  
Timing Plan: A.M. PEAK

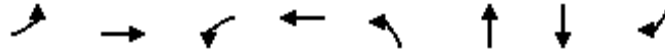

Lane Group	EBL	EBT	WBL	WBT	NBL	NBT	SBT	SBR
Lane Group Flow (vph)	394	460	19	462	39	18	95	439
v/c Ratio	0.51	0.44	0.10	0.46	0.20	0.09	0.33	0.49
Control Delay	24.5	9.5	33.1	16.6	33.6	23.8	30.3	4.2
Queue Delay	0.0	0.0	0.0	0.0	0.0	0.0	0.0	0.0
Total Delay	24.5	9.5	33.1	16.6	33.6	23.8	30.3	4.2
Queue Length 50th (ft)	59	87	6	65	12	2	28	5
Queue Length 95th (ft)	144	190	32	108	53	25	98	66
Internal Link Dist (ft)		222		1709		136	301	
Turn Bay Length (ft)			100					
Base Capacity (vph)	1195	1630	199	2692	199	200	365	1048
Starvation Cap Reductn	0	0	0	0	0	0	0	0
Spillback Cap Reductn	0	0	0	0	0	0	0	0
Storage Cap Reductn	0	0	0	0	0	0	0	0
Reduced v/c Ratio	0.33	0.28	0.10	0.17	0.20	0.09	0.26	0.42
Intersection Summary								

Queues  
3: US 101 NB Off-Ramp & Shiloh Road

2028 Opening Year Alter. C Project Conditions  
Timing Plan: A.M. PEAK

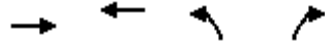

Lane Group	EBT	WBT	NBL	NBR
Lane Group Flow (vph)	334	717	647	616
v/c Ratio	0.21	0.87	0.86	0.40
Control Delay	11.8	29.9	31.3	2.1
Queue Delay	0.0	0.0	0.0	0.0
Total Delay	11.8	29.9	31.3	2.1
Queue Length 50th (ft)	44	268	248	0
Queue Length 95th (ft)	68	#471	293	10
Internal Link Dist (ft)	106	291	689	
Turn Bay Length (ft)				265
Base Capacity (vph)	1881	989	883	1699
Starvation Cap Reductn	0	0	0	0
Spillback Cap Reductn	0	0	0	0
Storage Cap Reductn	0	0	0	0
Reduced v/c Ratio	0.18	0.72	0.73	0.36

Intersection Summary

# 95th percentile volume exceeds capacity, queue may be longer.  
Queue shown is maximum after two cycles.

Queues  
4: Shiloh Road & US 101 SB Off-Ramp

2028 Opening Year Alter. C Project Conditions  
Timing Plan: A.M. PEAK

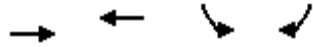

Lane Group	EBT	WBT	SBL	SBR
Lane Group Flow (vph)	292	746	125	189
v/c Ratio	0.28	0.71	0.32	0.38
Control Delay	5.0	10.4	18.3	6.3
Queue Delay	0.0	0.0	0.0	0.0
Total Delay	5.0	10.4	18.3	6.3
Queue Length 50th (ft)	25	88	22	0
Queue Length 95th (ft)	61	210	77	42
Internal Link Dist (ft)	145	226	406	
Turn Bay Length (ft)				275
Base Capacity (vph)	1863	1863	814	830
Starvation Cap Reductn	0	0	0	0
Spillback Cap Reductn	0	0	0	0
Storage Cap Reductn	0	0	0	0
Reduced v/c Ratio	0.16	0.40	0.15	0.23
<b>Intersection Summary</b>				

Queues  
6: Conde Lane & Shiloh Road

2028 Opening Year Alter. C Project Conditions  
Timing Plan: A.M. PEAK

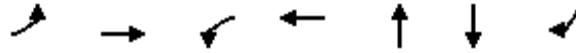

Lane Group	EBL	EBT	WBL	WBT	NBT	SBT	SBR
Lane Group Flow (vph)	29	399	12	747	34	272	47
v/c Ratio	0.08	0.27	0.03	0.56	0.07	0.56	0.08
Control Delay	25.4	10.6	25.7	13.0	0.3	30.1	13.3
Queue Delay	0.0	0.0	0.0	0.0	0.0	0.0	0.0
Total Delay	25.4	10.6	25.7	13.0	0.3	30.1	13.3
Queue Length 50th (ft)	5	21	2	36	0	47	4
Queue Length 95th (ft)	35	96	18	152	0	#247	32
Internal Link Dist (ft)		735		1001	338	442	
Turn Bay Length (ft)	90		127				40
Base Capacity (vph)	394	2977	350	2819	1288	483	1325
Starvation Cap Reductn	0	0	0	0	0	0	0
Spillback Cap Reductn	0	0	0	0	0	0	0
Storage Cap Reductn	0	0	0	0	0	0	0
Reduced v/c Ratio	0.07	0.13	0.03	0.26	0.03	0.56	0.04

Intersection Summary

# 95th percentile volume exceeds capacity, queue may be longer.  
Queue shown is maximum after two cycles.

Queues

10: US 101 NB Off Ramp/Lakewood Drive & Old Redwood Highway



Lane Group	EBL	EBT	WBT	NBL	NBT	SBL	SBR
Lane Group Flow (vph)	204	211	816	221	446	151	683
v/c Ratio	0.54	0.22	0.67	0.61	0.59	0.50	0.86
Control Delay	40.3	12.6	24.5	34.9	27.7	41.8	24.8
Queue Delay	0.0	0.0	0.0	0.0	0.0	0.0	0.0
Total Delay	40.3	12.6	24.5	34.9	27.7	41.8	24.8
Queue Length 50th (ft)	49	54	165	107	97	37	183
Queue Length 95th (ft)	86	107	237	181	143	72	332
Internal Link Dist (ft)		146	537		636		
Turn Bay Length (ft)	155			270		120	
Base Capacity (vph)	393	952	1225	594	1222	305	799
Starvation Cap Reductn	0	0	0	0	0	0	0
Spillback Cap Reductn	0	0	0	0	0	0	0
Storage Cap Reductn	0	0	0	0	0	0	0
Reduced v/c Ratio	0.52	0.22	0.67	0.37	0.36	0.50	0.85

Intersection Summary

Queues

12: US 101 SB On Ramp/US 101 SB Off Ramp & Old Redwood Highway



Lane Group	EBT	EBR	WBL	WBT	SBL	SBT
Lane Group Flow (vph)	368	366	656	645	121	112
v/c Ratio	0.31	0.48	1.02	0.24	0.58	0.41
Control Delay	20.3	5.2	69.4	3.2	45.0	15.7
Queue Delay	0.0	0.0	0.0	0.0	0.0	0.0
Total Delay	20.3	5.2	69.4	3.2	45.0	15.7
Queue Length 50th (ft)	70	5	~338	40	61	10
Queue Length 95th (ft)	104	62	#544	54	104	46
Internal Link Dist (ft)	343			451		751
Turn Bay Length (ft)			250		420	
Base Capacity (vph)	1203	760	641	2663	210	272
Starvation Cap Reductn	0	0	0	0	0	0
Spillback Cap Reductn	0	0	0	0	0	0
Storage Cap Reductn	0	0	0	0	0	0
Reduced v/c Ratio	0.31	0.48	1.02	0.24	0.58	0.41

Intersection Summary

~ Volume exceeds capacity, queue is theoretically infinite.

Queue shown is maximum after two cycles.

# 95th percentile volume exceeds capacity, queue may be longer.

Queue shown is maximum after two cycles.

Queues  
1: Old Redwood Hwy & Shiloh Road

2028 Opening Year Alter. C Project Conditions

Timing Plan: P.M. Peak



Lane Group	EBL	EBT	EBR	WBT	WBR	NBL	NBT	NBR	SBL	SBT	SBR
Lane Group Flow (vph)	299	166	229	211	27	214	417	26	37	291	197
v/c Ratio	0.71	0.37	0.41	0.63	0.07	0.74	0.60	0.04	0.32	0.69	0.45
Control Delay	44.0	34.1	7.0	46.4	0.4	58.2	31.4	0.1	56.1	43.8	18.1
Queue Delay	0.0	0.0	0.0	0.0	0.0	0.0	0.0	0.0	0.0	0.0	0.0
Total Delay	44.0	34.1	7.0	46.4	0.4	58.2	31.4	0.1	56.1	43.8	18.1
Queue Length 50th (ft)	157	79	0	113	0	119	210	0	21	155	39
Queue Length 95th (ft)	308	170	62	227	0	#327	386	0	65	289	117
Internal Link Dist (ft)		1709		528			668			695	
Turn Bay Length (ft)	375		140		50	200		98	130		93
Base Capacity (vph)	608	639	694	788	722	288	912	796	119	734	677
Starvation Cap Reductn	0	0	0	0	0	0	0	0	0	0	0
Spillback Cap Reductn	0	0	0	0	0	0	0	0	0	0	0
Storage Cap Reductn	0	0	0	0	0	0	0	0	0	0	0
Reduced v/c Ratio	0.49	0.26	0.33	0.27	0.04	0.74	0.46	0.03	0.31	0.40	0.29

Intersection Summary

# 95th percentile volume exceeds capacity, queue may be longer.  
Queue shown is maximum after two cycles.

## Queues

## 2028 Opening Year Alter. C Project Conditions

## 2: Shiloh Road &amp; Hembree Ln

Timing Plan: P.M. Peak

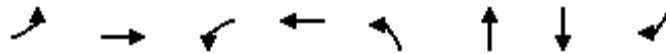

Lane Group	EBL	EBT	WBL	WBT	NBL	NBT	SBT	SBR
Lane Group Flow (vph)	745	589	24	644	65	26	215	595
v/c Ratio	0.82	0.57	0.16	0.62	0.43	0.16	0.78	0.70
Control Delay	35.6	13.2	36.2	19.7	43.9	24.9	53.0	13.0
Queue Delay	0.0	0.0	0.0	0.0	0.0	0.0	0.0	0.0
Total Delay	35.6	13.2	36.2	19.7	43.9	24.9	53.0	13.0
Queue Length 50th (ft)	143	127	9	102	25	4	84	48
Queue Length 95th (ft)	#356	276	37	139	#92	31	#269	#322
Internal Link Dist (ft)		222		1709		136	301	
Turn Bay Length (ft)			100					
Base Capacity (vph)	904	1486	150	2201	150	158	275	855
Starvation Cap Reductn	0	0	0	0	0	0	0	0
Spillback Cap Reductn	0	0	0	0	0	0	0	0
Storage Cap Reductn	0	0	0	0	0	0	0	0
Reduced v/c Ratio	0.82	0.40	0.16	0.29	0.43	0.16	0.78	0.70

## Intersection Summary

# 95th percentile volume exceeds capacity, queue may be longer.

Queue shown is maximum after two cycles.



Queues  
3: US 101 NB Off-Ramp & Shiloh Road

2028 Opening Year Alter. C Project Conditions  
Timing Plan: P.M. Peak

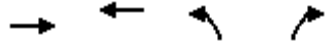

Lane Group	EBT	WBT	NBL	NBR
Lane Group Flow (vph)	496	738	666	883
v/c Ratio	0.31	0.89	0.87	0.60
Control Delay	12.8	32.7	32.8	8.6
Queue Delay	0.0	0.0	0.0	0.0
Total Delay	12.8	32.7	32.8	8.6
Queue Length 50th (ft)	69	280	260	67
Queue Length 95th (ft)	101	#493	#461	127
Internal Link Dist (ft)	106	291	689	
Turn Bay Length (ft)				265
Base Capacity (vph)	1795	944	843	1573
Starvation Cap Reductn	0	0	0	0
Spillback Cap Reductn	0	0	0	0
Storage Cap Reductn	0	0	0	0
Reduced v/c Ratio	0.28	0.78	0.79	0.56

Intersection Summary

# 95th percentile volume exceeds capacity, queue may be longer.  
Queue shown is maximum after two cycles.

Queues  
4: Shiloh Road & US 101 SB Off-Ramp

2028 Opening Year Alter. C Project Conditions  
Timing Plan: P.M. Peak

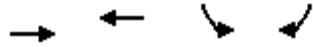

Lane Group	EBT	WBT	SBL	SBR
Lane Group Flow (vph)	565	749	178	157
v/c Ratio	0.54	0.71	0.43	0.32
Control Delay	7.9	11.2	20.0	6.1
Queue Delay	0.0	0.0	0.0	0.0
Total Delay	7.9	11.2	20.0	6.1
Queue Length 50th (ft)	65	100	36	0
Queue Length 95th (ft)	154	246	106	39
Internal Link Dist (ft)	145	226	406	
Turn Bay Length (ft)				275
Base Capacity (vph)	1863	1863	758	753
Starvation Cap Reductn	0	0	0	0
Spillback Cap Reductn	0	0	0	0
Storage Cap Reductn	0	0	0	0
Reduced v/c Ratio	0.30	0.40	0.23	0.21
<b>Intersection Summary</b>				

Queues  
6: Conde Lane & Shiloh Road

2028 Opening Year Alter. C Project Conditions  
Timing Plan: P.M. Peak

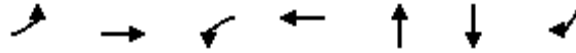

Lane Group	EBL	EBT	WBL	WBT	NBT	SBT	SBR
Lane Group Flow (vph)	90	616	10	1066	45	384	50
v/c Ratio	0.34	0.33	0.04	0.73	0.14	1.13	0.08
Control Delay	36.8	9.9	34.6	17.7	18.9	122.5	13.6
Queue Delay	0.0	0.0	0.0	0.0	0.0	0.0	0.0
Total Delay	36.8	9.9	34.6	17.7	18.9	122.5	13.6
Queue Length 50th (ft)	40	73	4	194	6	~253	14
Queue Length 95th (ft)	92	141	18	214	22	#469	33
Internal Link Dist (ft)		735		1001	338	442	
Turn Bay Length (ft)	90		127				40
Base Capacity (vph)	279	2439	248	2248	975	341	1053
Starvation Cap Reductn	0	0	0	0	0	0	0
Spillback Cap Reductn	0	0	0	0	0	0	0
Storage Cap Reductn	0	0	0	0	0	0	0
Reduced v/c Ratio	0.32	0.25	0.04	0.47	0.05	1.13	0.05

Intersection Summary

- ~ Volume exceeds capacity, queue is theoretically infinite.  
Queue shown is maximum after two cycles.
- # 95th percentile volume exceeds capacity, queue may be longer.  
Queue shown is maximum after two cycles.

Queues

10: US 101 NB Off Ramp/Lakewood Drive & Old Redwood Highway



Lane Group	EBL	EBT	WBT	NBL	NBT	SBL	SBR
Lane Group Flow (vph)	341	470	873	482	957	296	684
v/c Ratio	0.99	0.56	0.82	0.93	0.88	1.11	0.76
Control Delay	89.6	21.7	34.7	56.9	37.7	127.8	17.9
Queue Delay	0.0	0.0	0.0	0.0	0.0	0.0	0.0
Total Delay	89.6	21.7	34.7	56.9	37.7	127.8	17.9
Queue Length 50th (ft)	101	191	225	289	259	~100	187
Queue Length 95th (ft)	#179	273	301	#498	#381	#181	342
Internal Link Dist (ft)		146	537		636		
Turn Bay Length (ft)	155			270		120	
Base Capacity (vph)	343	832	1063	518	1082	267	895
Starvation Cap Reductn	0	0	0	0	0	0	0
Spillback Cap Reductn	0	0	0	0	0	0	0
Storage Cap Reductn	0	0	0	0	0	0	0
Reduced v/c Ratio	0.99	0.56	0.82	0.93	0.88	1.11	0.76

Intersection Summary

~ Volume exceeds capacity, queue is theoretically infinite.

Queue shown is maximum after two cycles.

# 95th percentile volume exceeds capacity, queue may be longer.

Queue shown is maximum after two cycles.

Queues

12: US 101 SB On Ramp/US 101 SB Off Ramp & Old Redwood Highway



Lane Group	EBT	EBR	WBL	WBT	SBL	SBT
Lane Group Flow (vph)	648	462	488	1310	217	201
v/c Ratio	0.46	0.52	1.07	0.52	0.88	0.66
Control Delay	16.8	4.1	91.7	5.5	65.7	27.3
Queue Delay	0.0	0.0	0.0	0.0	0.0	0.0
Total Delay	16.8	4.1	91.7	5.5	65.7	27.3
Queue Length 50th (ft)	104	2	~239	107	97	45
Queue Length 95th (ft)	148	55	#403	141	#194	97
Internal Link Dist (ft)	343			451		751
Turn Bay Length (ft)			250		420	
Base Capacity (vph)	1410	893	455	2522	247	305
Starvation Cap Reductn	0	0	0	0	0	0
Spillback Cap Reductn	0	0	0	0	0	0
Storage Cap Reductn	0	0	0	0	0	0
Reduced v/c Ratio	0.46	0.52	1.07	0.52	0.88	0.66

Intersection Summary

~ Volume exceeds capacity, queue is theoretically infinite.

Queue shown is maximum after two cycles.

# 95th percentile volume exceeds capacity, queue may be longer.

Queue shown is maximum after two cycles.

Queues  
1: Old Redwood Hwy & Shiloh Road

2028 Opening Year Alter. C Project Conditions  
Timing Plan: Saturday Midday Peak



Lane Group	EBL	EBT	EBR	WBT	WBR	NBL	NBT	NBR	SBL	SBT	SBR
Lane Group Flow (vph)	175	210	248	261	37	244	290	29	41	241	263
v/c Ratio	0.51	0.58	0.50	0.66	0.09	0.81	0.43	0.05	0.34	0.63	0.57
Control Delay	38.2	39.8	8.3	41.1	0.4	59.5	26.7	0.1	53.6	40.8	16.2
Queue Delay	0.0	0.0	0.0	0.0	0.0	0.0	0.0	0.0	0.0	0.0	0.0
Total Delay	38.2	39.8	8.3	41.1	0.4	59.5	26.7	0.1	53.6	40.8	16.2
Queue Length 50th (ft)	81	99	0	123	0	122	121	0	21	114	34
Queue Length 95th (ft)	176	208	62	242	0	#370	258	0	#73	239	129
Internal Link Dist (ft)		1709		528			668			695	
Turn Bay Length (ft)	375		140		50	200		98	130		93
Base Capacity (vph)	662	697	734	863	798	303	994	865	119	800	766
Starvation Cap Reductn	0	0	0	0	0	0	0	0	0	0	0
Spillback Cap Reductn	0	0	0	0	0	0	0	0	0	0	0
Storage Cap Reductn	0	0	0	0	0	0	0	0	0	0	0
Reduced v/c Ratio	0.26	0.30	0.34	0.30	0.05	0.81	0.29	0.03	0.34	0.30	0.34

Intersection Summary

# 95th percentile volume exceeds capacity, queue may be longer.  
Queue shown is maximum after two cycles.

## Queues

2028 Opening Year Alter. C Project Conditions

## 2: Shiloh Road &amp; Hembree Ln

Timing Plan: Saturday Midday Peak

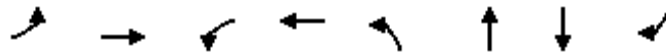

Lane Group	EBL	EBT	WBL	WBT	NBL	NBT	SBT	SBR
Lane Group Flow (vph)	753	562	24	634	65	26	211	732
v/c Ratio	0.83	0.52	0.16	0.62	0.43	0.16	0.76	0.85
Control Delay	35.5	10.9	35.9	19.5	43.4	24.7	50.5	21.3
Queue Delay	0.0	0.0	0.0	0.0	0.0	0.0	0.0	0.0
Total Delay	35.5	10.9	35.9	19.5	43.4	24.7	50.5	21.3
Queue Length 50th (ft)	144	119	9	98	25	4	81	77
Queue Length 95th (ft)	#362	258	37	142	#92	31	#263	#559
Internal Link Dist (ft)		222		1709		136	301	
Turn Bay Length (ft)			100					
Base Capacity (vph)	910	1494	152	2213	152	159	277	866
Starvation Cap Reductn	0	0	0	0	0	0	0	0
Spillback Cap Reductn	0	0	0	0	0	0	0	0
Storage Cap Reductn	0	0	0	0	0	0	0	0
Reduced v/c Ratio	0.83	0.38	0.16	0.29	0.43	0.16	0.76	0.85

## Intersection Summary

# 95th percentile volume exceeds capacity, queue may be longer.

Queue shown is maximum after two cycles.

Queues  
3: US 101 NB Off-Ramp & Shiloh Road

2028 Opening Year Alter. C Project Conditions  
Timing Plan: Saturday Midday Peak

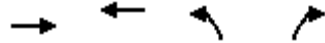

Lane Group	EBT	WBT	NBL	NBR
Lane Group Flow (vph)	542	976	422	774
v/c Ratio	0.30	1.01	0.71	0.64
Control Delay	10.3	51.8	24.9	10.3
Queue Delay	0.0	0.0	0.0	0.0
Total Delay	10.3	51.8	24.9	10.3
Queue Length 50th (ft)	56	~353	136	60
Queue Length 95th (ft)	113	#729	221	113
Internal Link Dist (ft)	106	291	689	
Turn Bay Length (ft)				265
Base Capacity (vph)	1835	965	861	1561
Starvation Cap Reductn	0	0	0	0
Spillback Cap Reductn	0	0	0	0
Storage Cap Reductn	0	0	0	0
Reduced v/c Ratio	0.30	1.01	0.49	0.50

Intersection Summary

- ~ Volume exceeds capacity, queue is theoretically infinite.  
Queue shown is maximum after two cycles.
- # 95th percentile volume exceeds capacity, queue may be longer.  
Queue shown is maximum after two cycles.



Queues  
4: Shiloh Road & US 101 SB Off-Ramp

2028 Opening Year Alter. C Project Conditions  
Timing Plan: Saturday Midday Peak

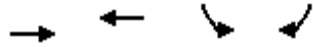

Lane Group	EBT	WBT	SBL	SBR
Lane Group Flow (vph)	340	635	375	256
v/c Ratio	0.40	0.76	0.60	0.35
Control Delay	9.8	16.9	20.0	4.1
Queue Delay	0.0	0.0	0.0	0.0
Total Delay	9.8	16.9	20.0	4.1
Queue Length 50th (ft)	56	131	79	0
Queue Length 95th (ft)	99	222	132	15
Internal Link Dist (ft)	145	226	406	
Turn Bay Length (ft)				275
Base Capacity (vph)	1863	1863	628	726
Starvation Cap Reductn	0	0	0	0
Spillback Cap Reductn	0	0	0	0
Storage Cap Reductn	0	0	0	0
Reduced v/c Ratio	0.18	0.34	0.60	0.35
<b>Intersection Summary</b>				

Queues  
6: Conde Lane & Shiloh Road

2028 Opening Year Alter. C Project Conditions  
Timing Plan: Saturday Midday Peak

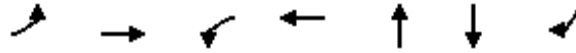

Lane Group	EBL	EBT	WBL	WBT	NBT	SBT	SBR
Lane Group Flow (vph)	34	428	11	758	14	287	41
v/c Ratio	0.10	0.28	0.03	0.58	0.03	0.59	0.07
Control Delay	23.5	9.9	24.0	12.9	0.1	28.1	12.2
Queue Delay	0.0	0.0	0.0	0.0	0.0	0.0	0.0
Total Delay	23.5	9.9	24.0	12.9	0.1	28.1	12.2
Queue Length 50th (ft)	5	24	2	42	0	46	4
Queue Length 95th (ft)	40	107	19	183	0	#242	27
Internal Link Dist (ft)		735		1001	338	442	
Turn Bay Length (ft)	90		127				40
Base Capacity (vph)	376	3095	353	2919	1323	486	1379
Starvation Cap Reductn	0	0	0	0	0	0	0
Spillback Cap Reductn	0	0	0	0	0	0	0
Storage Cap Reductn	0	0	0	0	0	0	0
Reduced v/c Ratio	0.09	0.14	0.03	0.26	0.01	0.59	0.03

Intersection Summary

# 95th percentile volume exceeds capacity, queue may be longer.  
Queue shown is maximum after two cycles.

Queues

2028 Opening Year Alter. C Project Conditions

10: US 101 NB Off Ramp/Lakewood Drive & Old Redwood Highway Timing Plan: Saturday Midday Peak



Lane Group	EBL	EBT	WBT	NBL	NBT	SBL	SBR
Lane Group Flow (vph)	302	347	895	262	519	277	795
v/c Ratio	0.96	0.37	0.72	0.66	0.61	0.94	0.99
Control Delay	81.7	15.3	24.8	35.6	26.8	80.3	47.2
Queue Delay	0.0	0.0	0.0	0.0	0.0	0.0	0.0
Total Delay	81.7	15.3	24.8	35.6	26.8	80.3	47.2
Queue Length 50th (ft)	81	105	182	131	113	74	282
Queue Length 95th (ft)	#180	200	284	215	163	#162	#526
Internal Link Dist (ft)		146	537		636		
Turn Bay Length (ft)	155			270		120	
Base Capacity (vph)	315	932	1250	576	1191	294	800
Starvation Cap Reductn	0	0	0	0	0	0	0
Spillback Cap Reductn	0	0	0	0	0	0	0
Storage Cap Reductn	0	0	0	0	0	0	0
Reduced v/c Ratio	0.96	0.37	0.72	0.45	0.44	0.94	0.99

Intersection Summary

# 95th percentile volume exceeds capacity, queue may be longer.  
 Queue shown is maximum after two cycles.

Queues

2028 Opening Year Alter. C Project Conditions

12: US 101 SB On Ramp/US 101 SB Off Ramp & Old Redwood Highway Timing Plan: Saturday Midday Peak



Lane Group	EBT	EBR	WBL	WBT	SBL	SBT
Lane Group Flow (vph)	567	432	507	852	184	171
v/c Ratio	0.40	0.49	1.09	0.33	0.76	0.52
Control Delay	16.2	3.8	94.8	3.9	50.7	16.3
Queue Delay	0.0	0.0	0.0	0.0	0.0	0.0
Total Delay	16.2	3.8	94.8	3.9	50.7	16.3
Queue Length 50th (ft)	89	0	~251	54	81	20
Queue Length 95th (ft)	128	50	#424	74	#116	48
Internal Link Dist (ft)	343			451		751
Turn Bay Length (ft)			250		420	
Base Capacity (vph)	1406	877	467	2569	244	330
Starvation Cap Reductn	0	0	0	0	0	0
Spillback Cap Reductn	0	0	0	0	0	0
Storage Cap Reductn	0	0	0	0	0	0
Reduced v/c Ratio	0.40	0.49	1.09	0.33	0.75	0.52

Intersection Summary

~ Volume exceeds capacity, queue is theoretically infinite.

Queue shown is maximum after two cycles.

# 95th percentile volume exceeds capacity, queue may be longer.

Queue shown is maximum after two cycles.

Lanes, Volumes, Timings  
1: Old Redwood Hwy & Shiloh Road

2028 Opening Year Alter. C Project Conditions

Timing Plan: A.M. PEAK

Lane Group	EBL	EBT	EBR	WBL	WBT	WBR	NBL	NBT	NBR	SBL	SBT	SBR
Lane Configurations												
Traffic Volume (vph)	137	176	109	25	98	18	102	143	39	22	265	208
Future Volume (vph)	137	176	109	25	98	18	102	143	39	22	265	208
Ideal Flow (vphpl)	1900	1900	1900	1900	1900	1900	1900	1900	1900	1900	1900	1900
Storage Length (ft)	375		140	0		50	200		98	130		93
Storage Lanes	1		1	0		1	1		1	1		1
Taper Length (ft)	50			25			60			93		
Lane Util. Factor	1.00	1.00	1.00	1.00	1.00	1.00	1.00	1.00	1.00	1.00	1.00	1.00
Ped Bike Factor												0.98
Frt			0.850			0.850			0.850			0.850
Flt Protected	0.950				0.990		0.950			0.950		
Satd. Flow (prot)	1770	1863	1583	0	1844	1583	1770	1863	1583	1770	1863	1583
Flt Permitted	0.950				0.990		0.950			0.950		
Satd. Flow (perm)	1770	1863	1583	0	1844	1583	1770	1863	1583	1770	1863	1549
Right Turn on Red			Yes			Yes			Yes			Yes
Satd. Flow (RTOR)			135			105			77			133
Link Speed (mph)		40			40			45			40	
Link Distance (ft)		1789			608			748			775	
Travel Time (s)		30.5			10.4			11.3			13.2	
Confl. Bikes (#/hr)												1
Peak Hour Factor	0.81	0.81	0.81	0.89	0.89	0.89	0.93	0.93	0.93	0.85	0.85	0.85
Adj. Flow (vph)	169	217	135	28	110	20	110	154	42	26	312	245
Shared Lane Traffic (%)												
Lane Group Flow (vph)	169	217	135	0	138	20	110	154	42	26	312	245
Enter Blocked Intersection	No	No	No	No	No	No	No	No	No	No	No	No
Lane Alignment	Left	Left	Right	Left	Left	Right	Left	Left	Right	Left	Left	Right
Median Width(ft)		12			12			12			12	
Link Offset(ft)		0			0			0			0	
Crosswalk Width(ft)		16			16			16			16	
Two way Left Turn Lane												
Headway Factor	1.00	1.00	1.00	1.00	1.00	1.00	1.00	1.00	1.00	1.00	1.00	1.00
Turning Speed (mph)	15		9	15		9	15		9	15		9
Number of Detectors	1	2	1	1	2	1	1	2	1	1	2	1
Detector Template	Left	Thru	Right	Left	Thru	Right	Left	Thru	Right	Left	Thru	Right
Leading Detector (ft)	20	100	20	20	100	20	20	100	20	20	100	20
Trailing Detector (ft)	0	0	0	0	0	0	0	0	0	0	0	0
Detector 1 Position(ft)	0	0	0	0	0	0	0	0	0	0	0	0
Detector 1 Size(ft)	20	6	20	20	6	20	20	6	20	20	6	20
Detector 1 Type	Cl+Ex	Cl+Ex	Cl+Ex	Cl+Ex	Cl+Ex	Cl+Ex	Cl+Ex	Cl+Ex	Cl+Ex	Cl+Ex	Cl+Ex	Cl+Ex
Detector 1 Channel												
Detector 1 Extend (s)	0.0	0.0	0.0	0.0	0.0	0.0	0.0	0.0	0.0	0.0	0.0	0.0
Detector 1 Queue (s)	0.0	0.0	0.0	0.0	0.0	0.0	0.0	0.0	0.0	0.0	0.0	0.0
Detector 1 Delay (s)	0.0	0.0	0.0	0.0	0.0	0.0	0.0	0.0	0.0	0.0	0.0	0.0
Detector 2 Position(ft)		94			94			94			94	
Detector 2 Size(ft)		6			6			6			6	
Detector 2 Type		Cl+Ex			Cl+Ex			Cl+Ex			Cl+Ex	
Detector 2 Channel												
Detector 2 Extend (s)		0.0			0.0			0.0			0.0	
Turn Type	Split	NA	Perm	Split	NA	Perm	Prot	NA	Perm	Prot	NA	Perm

Lanes, Volumes, Timings  
1: Old Redwood Hwy & Shiloh Road

2028 Opening Year Alter. C Project Conditions  
Timing Plan: A.M. PEAK

Lane Group	EBL	EBT	EBR	WBL	WBT	WBR	NBL	NBT	NBR	SBL	SBT	SBR
Protected Phases	2	2		6	6		3	8		7	4	
Permitted Phases			2			6			8			4
Detector Phase	2	2	2	6	6	6	3	8	8	7	4	4
Switch Phase												
Minimum Initial (s)	5.0	5.0	5.0	5.0	5.0	5.0	5.0	5.0	5.0	5.0	5.0	5.0
Minimum Split (s)	34.5	34.5	34.5	42.5	42.5	42.5	8.5	46.5	46.5	8.5	39.5	39.5
Total Split (s)	35.0	35.0	35.0	42.5	42.5	42.5	18.0	48.0	48.0	9.5	39.5	39.5
Total Split (%)	25.9%	25.9%	25.9%	31.5%	31.5%	31.5%	13.3%	35.6%	35.6%	7.0%	29.3%	29.3%
Maximum Green (s)	30.5	30.5	30.5	38.0	38.0	38.0	14.5	43.5	43.5	6.0	35.0	35.0
Yellow Time (s)	3.5	3.5	3.5	3.5	3.5	3.5	3.0	3.5	3.5	3.0	3.5	3.5
All-Red Time (s)	1.0	1.0	1.0	1.0	1.0	1.0	0.5	1.0	1.0	0.5	1.0	1.0
Lost Time Adjust (s)	0.0	0.0	0.0		0.0	0.0	0.0	0.0	0.0	0.0	0.0	0.0
Total Lost Time (s)	4.5	4.5	4.5		4.5	4.5	3.5	4.5	4.5	3.5	4.5	4.5
Lead/Lag	Lead	Lead	Lead	Lag	Lag	Lag	Lead	Lag	Lag	Lead	Lag	Lag
Lead-Lag Optimize?	Yes	Yes	Yes	Yes	Yes	Yes	Yes	Yes	Yes	Yes	Yes	Yes
Vehicle Extension (s)	3.0	3.0	3.0	3.0	3.0	3.0	3.0	3.0	3.0	3.0	3.0	3.0
Recall Mode	None	None	None	None	None	None	None	None	None	None	None	None
Walk Time (s)	7.0	7.0	7.0	7.0	7.0	7.0		7.0	7.0		7.0	7.0
Flash Don't Walk (s)	23.0	23.0	23.0	31.0	31.0	31.0		35.0	35.0		28.0	28.0
Pedestrian Calls (#/hr)	0	0	0	0	0	0		0	0		0	0
Act Effct Green (s)	16.1	16.1	16.1		12.4	12.4	11.0	28.4	28.4	6.5	20.2	20.2
Actuated g/C Ratio	0.22	0.22	0.22		0.17	0.17	0.15	0.38	0.38	0.09	0.27	0.27
v/c Ratio	0.44	0.54	0.30		0.45	0.06	0.42	0.22	0.06	0.17	0.62	0.48
Control Delay (s/veh)	33.8	35.5	8.1		38.8	0.3	40.9	19.0	1.5	44.4	32.8	16.1
Queue Delay	0.0	0.0	0.0		0.0	0.0	0.0	0.0	0.0	0.0	0.0	0.0
Total Delay (s/veh)	33.8	35.5	8.1		38.8	0.3	40.9	19.0	1.5	44.4	32.8	16.1
LOS	C	D	A		D	A	D	B	A	D	C	B
Approach Delay (s/veh)		27.8			34.0			24.5			26.3	
Approach LOS		C			C			C			C	

Intersection Summary





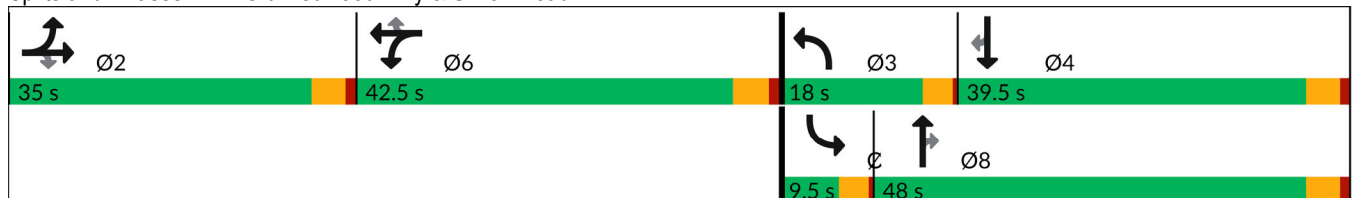















Area Type:	Other
Cycle Length:	135
Actuated Cycle Length:	74.8
Natural Cycle:	135
Control Type:	Actuated-Uncoordinated
Maximum v/c Ratio:	0.62
Intersection Signal Delay (s/veh):	27.2
Intersection LOS:	C
Intersection Capacity Utilization:	50.0%
ICU Level of Service:	A
Analysis Period (min):	15

Splits and Phases: 1: Old Redwood Hwy & Shiloh Road



Lanes, Volumes, Timings  
2: Shiloh Road & Hembree Ln

2028 Opening Year Alter. C Project Conditions  
Timing Plan: A.M. PEAK

												
Lane Group	EBL	EBT	EBR	WBL	WBT	WBR	NBL	NBT	NBR	SBL	SBT	SBR
Lane Configurations												
Traffic Volume (vph)	347	371	38	19	366	82	39	7	11	81	9	413
Future Volume (vph)	347	371	38	19	366	82	39	7	11	81	9	413
Ideal Flow (vphpl)	1900	1900	1900	1900	1900	1900	1900	1900	1900	1900	1900	1900
Storage Length (ft)	0		0	100		130	0		0	0		0
Storage Lanes	2		0	1		1	1		0	0		1
Taper Length (ft)	25			50			25			25		
Lane Util. Factor	0.97	1.00	1.00	1.00	0.95	0.95	1.00	1.00	1.00	1.00	1.00	1.00
Frt		0.988			0.972			0.908				0.850
Flt Protected	0.950			0.950			0.950				0.957	
Satd. Flow (prot)	3433	1840	0	1770	3440	0	1770	1691	0	0	1783	1583
Flt Permitted	0.950			0.950			0.950				0.957	
Satd. Flow (perm)	3433	1840	0	1770	3440	0	1770	1691	0	0	1783	1583
Right Turn on Red			Yes			Yes			Yes			Yes
Satd. Flow (RTOR)		9			40			11				391
Link Speed (mph)		40			40			30				35
Link Distance (ft)		302			1789			216				381
Travel Time (s)		5.1			30.5			4.9				7.4
Peak Hour Factor	0.88	0.88	1.00	1.00	0.97	0.97	1.00	1.00	1.00	0.94	1.00	0.94
Adj. Flow (vph)	394	422	38	19	377	85	39	7	11	86	9	439
Shared Lane Traffic (%)												
Lane Group Flow (vph)	394	460	0	19	462	0	39	18	0	0	95	439
Enter Blocked Intersection	No	No	No	No	No	No	No	No	No	No	No	No
Lane Alignment	Left	Left	Right	Left	Left	Right	Left	Left	Right	Left	Left	Right
Median Width(ft)		24			24			12				12
Link Offset(ft)		0			0			0				0
Crosswalk Width(ft)		16			16			16				16
Two way Left Turn Lane												
Headway Factor	1.00	1.00	1.00	1.00	1.00	1.00	1.00	1.00	1.00	1.00	1.00	1.00
Turning Speed (mph)	15		60	60		9	60		60	15		9
Number of Detectors	1	2		1	2		1	2		1	2	1
Detector Template	Left	Thru		Left	Thru		Left	Thru		Left	Thru	Right
Leading Detector (ft)	20	100		20	100		20	100		20	100	20
Trailing Detector (ft)	0	0		0	0		0	0		0	0	0
Detector 1 Position(ft)	0	0		0	0		0	0		0	0	0
Detector 1 Size(ft)	20	6		20	6		20	6		20	6	20
Detector 1 Type	Cl+Ex	Cl+Ex		Cl+Ex	Cl+Ex		Cl+Ex	Cl+Ex		Cl+Ex	Cl+Ex	Cl+Ex
Detector 1 Channel												
Detector 1 Extend (s)	0.0	0.0		0.0	0.0		0.0	0.0		0.0	0.0	0.0
Detector 1 Queue (s)	0.0	0.0		0.0	0.0		0.0	0.0		0.0	0.0	0.0
Detector 1 Delay (s)	0.0	0.0		0.0	0.0		0.0	0.0		0.0	0.0	0.0
Detector 2 Position(ft)		94			94			94				94
Detector 2 Size(ft)		6			6			6				6
Detector 2 Type		Cl+Ex			Cl+Ex			Cl+Ex				Cl+Ex
Detector 2 Channel												
Detector 2 Extend (s)		0.0			0.0			0.0				0.0
Turn Type	Prot	NA		Prot	NA		Split	NA		Split	NA	pt+ov
Protected Phases	5	2		1	6		8	8		4	4	4
Permitted Phases												

Lanes, Volumes, Timings  
2: Shiloh Road & Hembree Ln

2028 Opening Year Alter. C Project Conditions

Timing Plan: A.M. PEAK

Lane Group	EBL	EBT	EBR	WBL	WBT	WBR	NBL	NBT	NBR	SBL	SBT	SBR
Detector Phase	5	2		1	6		8	8		4	4	4 5
Switch Phase												
Minimum Initial (s)	3.0	5.0		5.0	5.0		5.0	5.0		5.0	5.0	
Minimum Split (s)	7.5	9.5		9.5	43.5		9.5	9.5		9.5	9.5	
Total Split (s)	21.0	57.0		9.5	45.5		9.5	9.5		14.0	14.0	
Total Split (%)	23.3%	63.3%		10.6%	50.6%		10.6%	10.6%		15.6%	15.6%	
Maximum Green (s)	17.0	53.0		5.5	41.5		5.5	5.5		10.0	10.0	
Yellow Time (s)	3.0	3.0		3.0	3.0		3.0	3.0		3.0	3.0	
All-Red Time (s)	1.0	1.0		1.0	1.0		1.0	1.0		1.0	1.0	
Lost Time Adjust (s)	0.0	0.0		0.0	0.0		0.0	0.0			0.0	
Total Lost Time (s)	4.0	4.0		4.0	4.0		4.0	4.0			4.0	
Lead/Lag	Lead	Lag		Lead	Lag							
Lead-Lag Optimize?	Yes	Yes		Yes	Yes							
Vehicle Extension (s)	3.0	3.0		3.0	3.0		3.0	3.0		3.0	3.0	
Recall Mode	None	None		None	None		None	None		None	None	
Walk Time (s)					7.0							
Flash Don't Walk (s)					32.0							
Pedestrian Calls (#/hr)					1							
Act Effct Green (s)	12.3	31.2		6.2	15.5		6.2	6.2			8.9	23.7
Actuated g/C Ratio	0.22	0.57		0.11	0.28		0.11	0.11			0.16	0.43
v/c Ratio	0.51	0.44		0.10	0.46		0.20	0.09			0.33	0.49
Control Delay (s/veh)	24.5	9.5		33.1	16.6		33.6	23.8			30.3	4.2
Queue Delay	0.0	0.0		0.0	0.0		0.0	0.0			0.0	0.0
Total Delay (s/veh)	24.5	9.5		33.1	16.6		33.6	23.8			30.3	4.2
LOS	C	A		C	B		C	C			C	A
Approach Delay (s/veh)		16.4			17.3			30.5			8.9	
Approach LOS		B			B			C			A	

Intersection Summary

Area Type:	Other
Cycle Length:	90
Actuated Cycle Length:	55
Natural Cycle:	80
Control Type:	Actuated-Uncoordinated
Maximum v/c Ratio:	0.51
Intersection Signal Delay (s/veh):	15.0
Intersection LOS:	B
Intersection Capacity Utilization:	52.5%
ICU Level of Service:	A
Analysis Period (min):	15

Splits and Phases: 2: Shiloh Road & Hembree Ln

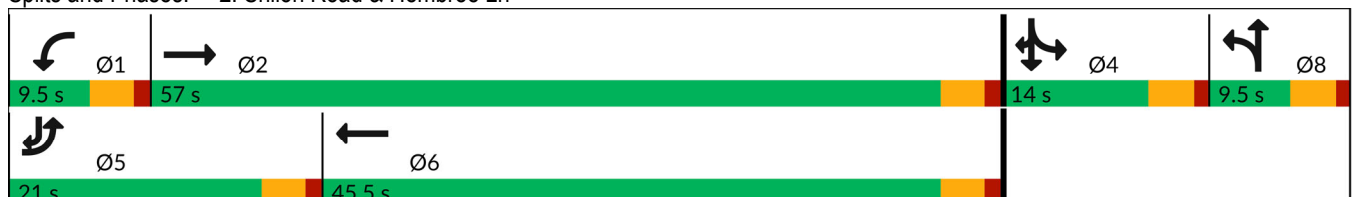



Lanes, Volumes, Timings  
 3: US 101 NB Off-Ramp & Shiloh Road

2028 Opening Year Alter. C Project Conditions

Timing Plan: A.M. PEAK

	→	↘	↙	←	↖	↗
Lane Group	EBT	EBR	WBL	WBT	NBL	NBR
Lane Configurations	↑↑			↑	↘	↗
Traffic Volume (vph)	304	0	0	645	492	468
Future Volume (vph)	304	0	0	645	492	468
Ideal Flow (vphpl)	1900	1900	1900	1900	1900	1900
Storage Length (ft)		0	0		0	265
Storage Lanes		0	0		1	2
Taper Length (ft)			25		25	
Lane Util. Factor	0.95	1.00	1.00	1.00	1.00	0.88
Frt						0.850
Flt Protected					0.950	
Satd. Flow (prot)	3539	0	0	1863	1770	2787
Flt Permitted					0.950	
Satd. Flow (perm)	3539	0	0	1863	1770	2787
Right Turn on Red		Yes				Yes
Satd. Flow (RTOR)						616
Link Speed (mph)	40			40	30	
Link Distance (ft)	186			371	769	
Travel Time (s)	3.2			6.3	17.5	
Peak Hour Factor	0.91	0.91	0.90	0.90	0.76	0.76
Adj. Flow (vph)	334	0	0	717	647	616
Shared Lane Traffic (%)						
Lane Group Flow (vph)	334	0	0	717	647	616
Enter Blocked Intersection	No	No	No	No	No	No
Lane Alignment	Left	Right	Left	Left	Left	Right
Median Width(ft)	0			0	12	
Link Offset(ft)	0			0	0	
Crosswalk Width(ft)	16			16	16	
Two way Left Turn Lane						
Headway Factor	1.00	1.00	1.00	1.00	1.00	1.00
Turning Speed (mph)		9	15		15	9
Number of Detectors	2			2	1	1
Detector Template	Thru			Thru	Left	Right
Leading Detector (ft)	100			100	20	20
Trailing Detector (ft)	0			0	0	0
Detector 1 Position(ft)	0			0	0	0
Detector 1 Size(ft)	6			6	20	20
Detector 1 Type	Cl+Ex			Cl+Ex	Cl+Ex	Cl+Ex
Detector 1 Channel						
Detector 1 Extend (s)	0.0			0.0	0.0	0.0
Detector 1 Queue (s)	0.0			0.0	0.0	0.0
Detector 1 Delay (s)	0.0			0.0	0.0	0.0
Detector 2 Position(ft)	94			94		
Detector 2 Size(ft)	6			6		
Detector 2 Type	Cl+Ex			Cl+Ex		
Detector 2 Channel						
Detector 2 Extend (s)	0.0			0.0		
Turn Type	NA			NA	Prot	Perm
Protected Phases	2			6	8	
Permitted Phases						8

Lanes, Volumes, Timings  
 3: US 101 NB Off-Ramp & Shiloh Road

2028 Opening Year Alter. C Project Conditions  
 Timing Plan: A.M. PEAK



Lane Group	EBT	EBR	WBL	WBT	NBL	NBR
Detector Phase	2			6	8	8
Switch Phase						
Minimum Initial (s)	5.0			5.0	5.0	5.0
Minimum Split (s)	9.0			9.0	9.0	9.0
Total Split (s)	37.0			37.0	35.0	35.0
Total Split (%)	51.4%			51.4%	48.6%	48.6%
Maximum Green (s)	33.0			33.0	31.0	31.0
Yellow Time (s)	3.0			3.0	3.0	3.0
All-Red Time (s)	1.0			1.0	1.0	1.0
Lost Time Adjust (s)	0.0			0.0	0.0	0.0
Total Lost Time (s)	4.0			4.0	4.0	4.0
Lead/Lag						
Lead-Lag Optimize?						
Vehicle Extension (s)	3.0			3.0	3.0	3.0
Recall Mode	None			None	None	None
Act Effect Green (s)	28.7			28.7	27.5	27.5
Actuated g/C Ratio	0.44			0.44	0.43	0.43
v/c Ratio	0.21			0.87	0.86	0.40
Control Delay (s/veh)	11.8			29.9	31.3	2.1
Queue Delay	0.0			0.0	0.0	0.0
Total Delay (s/veh)	11.8			29.9	31.3	2.1
LOS	B			C	C	A
Approach Delay (s/veh)	11.8			29.9	17.1	
Approach LOS	B			C	B	

Intersection Summary

Area Type: Other  
 Cycle Length: 72  
 Actuated Cycle Length: 64.5  
 Natural Cycle: 60  
 Control Type: Actuated-Uncoordinated  
 Maximum v/c Ratio: 0.87  
 Intersection Signal Delay (s/veh): 20.3  
 Intersection LOS: C  
 Intersection Capacity Utilization 94.3%  
 ICU Level of Service F  
 Analysis Period (min) 15

Splits and Phases: 3: US 101 NB Off-Ramp & Shiloh Road

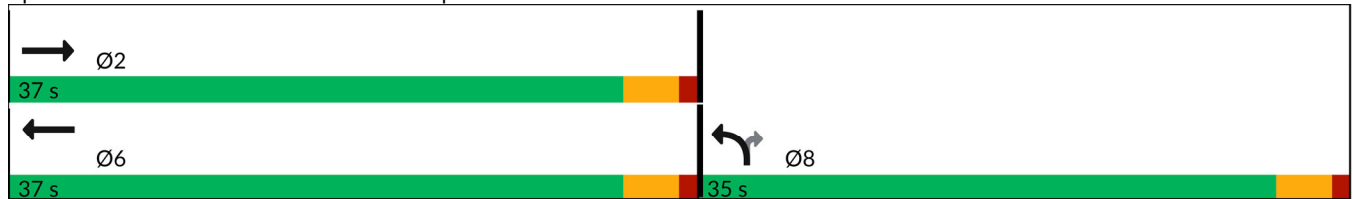

Lanes, Volumes, Timings  
4: Shiloh Road & US 101 SB Off-Ramp

2028 Opening Year Alter. C Project Conditions

Timing Plan: A.M. PEAK



Lane Group	EBL	EBT	WBT	WBR	SBL	SBR
Lane Configurations		↑	↑		↘	↗
Traffic Volume (vph)	0	272	679	0	115	174
Future Volume (vph)	0	272	679	0	115	174
Ideal Flow (vphpl)	1900	1900	1900	1900	1900	1900
Storage Length (ft)	0			0	0	275
Storage Lanes	0			0	1	1
Taper Length (ft)	25				25	
Lane Util. Factor	1.00	1.00	1.00	1.00	1.00	1.00
Frt						0.850
Flt Protected					0.950	
Satd. Flow (prot)	0	1863	1863	0	1770	1583
Flt Permitted					0.950	
Satd. Flow (perm)	0	1863	1863	0	1770	1583
Right Turn on Red				Yes		Yes
Satd. Flow (RTOR)						189
Link Speed (mph)		40	40		30	
Link Distance (ft)		225	306		486	
Travel Time (s)		3.8	5.2		11.0	
Peak Hour Factor	0.93	0.93	0.91	0.91	0.92	0.92
Adj. Flow (vph)	0	292	746	0	125	189
Shared Lane Traffic (%)						
Lane Group Flow (vph)	0	292	746	0	125	189
Enter Blocked Intersection	No	No	No	No	No	No
Lane Alignment	Left	Left	Left	Right	Left	Right
Median Width(ft)		4	0		12	
Link Offset(ft)		0	0		0	
Crosswalk Width(ft)		16	16		16	
Two way Left Turn Lane						
Headway Factor	1.00	1.00	1.00	1.00	1.00	1.00
Turning Speed (mph)	15			9	15	9
Number of Detectors		2	2		1	1
Detector Template		Thru	Thru		Left	Right
Leading Detector (ft)		100	100		20	20
Trailing Detector (ft)		0	0		0	0
Detector 1 Position(ft)		0	0		0	0
Detector 1 Size(ft)		6	6		20	20
Detector 1 Type		Cl+Ex	Cl+Ex		Cl+Ex	Cl+Ex
Detector 1 Channel						
Detector 1 Extend (s)		0.0	0.0		0.0	0.0
Detector 1 Queue (s)		0.0	0.0		0.0	0.0
Detector 1 Delay (s)		0.0	0.0		0.0	0.0
Detector 2 Position(ft)		94	94			
Detector 2 Size(ft)		6	6			
Detector 2 Type		Cl+Ex	Cl+Ex			
Detector 2 Channel						
Detector 2 Extend (s)		0.0	0.0			
Turn Type		NA	NA		Perm	Perm
Protected Phases		2	6			
Permitted Phases					4	4

Lanes, Volumes, Timings  
4: Shiloh Road & US 101 SB Off-Ramp

2028 Opening Year Alter. C Project Conditions  
Timing Plan: A.M. PEAK



Lane Group	EBL	EBT	WBT	WBR	SBL	SBR
Detector Phase		2	6		4	4
Switch Phase						
Minimum Initial (s)		5.0	5.0		5.0	5.0
Minimum Split (s)		9.0	38.0		9.0	9.0
Total Split (s)		69.0	69.0		21.0	21.0
Total Split (%)		76.7%	76.7%		23.3%	23.3%
Maximum Green (s)		65.0	65.0		17.0	17.0
Yellow Time (s)		3.0	3.0		3.0	3.0
All-Red Time (s)		1.0	1.0		1.0	1.0
Lost Time Adjust (s)		0.0	0.0		0.0	0.0
Total Lost Time (s)		4.0	4.0		4.0	4.0
Lead/Lag						
Lead-Lag Optimize?						
Vehicle Extension (s)		3.0	3.0		3.0	3.0
Recall Mode		None	None		None	None
Walk Time (s)			7.0			
Flash Don't Walk (s)			27.0			
Pedestrian Calls (#/hr)			0			
Act Effct Green (s)		22.4	22.4		8.6	8.6
Actuated g/C Ratio		0.57	0.57		0.22	0.22
v/c Ratio		0.28	0.71		0.32	0.38
Control Delay (s/veh)		5.0	10.4		18.3	6.3
Queue Delay		0.0	0.0		0.0	0.0
Total Delay (s/veh)		5.0	10.4		18.3	6.3
LOS		A	B		B	A
Approach Delay (s/veh)		5.0	10.4		11.1	
Approach LOS		A	B		B	

Intersection Summary

Area Type:	Other
Cycle Length:	90
Actuated Cycle Length:	39.6
Natural Cycle:	50
Control Type:	Actuated-Uncoordinated
Maximum v/c Ratio:	0.71
Intersection Signal Delay (s/veh):	9.4
Intersection LOS:	A
Intersection Capacity Utilization:	64.9%
ICU Level of Service:	C
Analysis Period (min):	15

Splits and Phases: 4: Shiloh Road & US 101 SB Off-Ramp

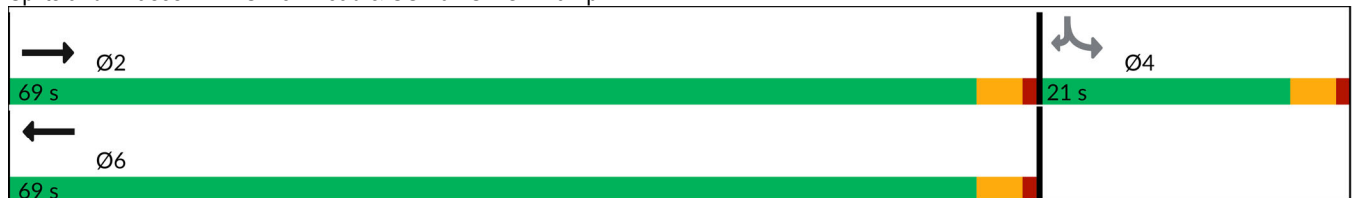

Lanes, Volumes, Timings  
5: Caletti Ave & Shiloh Road

2028 Opening Year Alter. C Project Conditions



















Timing Plan: A.M. PEAK

	→	↘	↙	←	↖	↗
Lane Group	EBT	EBR	WBL	WBT	NBL	NBR
Lane Configurations	↑↑		↘	↑	↘	↗
Traffic Volume (vph)	595	25	202	626	8	138
Future Volume (vph)	595	25	202	626	8	138
Ideal Flow (vphpl)	1900	1900	1900	1900	1900	1900
Storage Length (ft)		0	68		0	0
Storage Lanes		0	1		1	1
Taper Length (ft)			50		25	
Lane Util. Factor	0.95	0.95	1.00	1.00	1.00	1.00
Frt	0.994					0.850
Flt Protected			0.950		0.950	
Satd. Flow (prot)	3518	0	1770	1863	1770	1583
Flt Permitted			0.950		0.950	
Satd. Flow (perm)	3518	0	1770	1863	1770	1583
Link Speed (mph)	40			40	30	
Link Distance (ft)	1081			184	459	
Travel Time (s)	18.4			3.1	10.4	
Peak Hour Factor	0.96	0.96	0.87	0.87	0.84	0.84
Adj. Flow (vph)	620	26	232	720	10	164
Shared Lane Traffic (%)						
Lane Group Flow (vph)	646	0	232	720	10	164
Enter Blocked Intersection	No	No	No	No	No	No
Lane Alignment	Left	Right	Left	Left	Left	Right
Median Width(ft)	12			12	12	
Link Offset(ft)	0			0	0	
Crosswalk Width(ft)	16			16	16	
Two way Left Turn Lane						
Headway Factor	1.00	1.00	1.00	1.00	1.00	1.00
Turning Speed (mph)		9	15		15	9
Sign Control	Free			Free	Stop	
<b>Intersection Summary</b>						
Area Type:	Other					
Control Type:	Unsignalized					
Intersection Capacity Utilization	42.9%			ICU Level of Service A		
Analysis Period (min)	15					

Lanes, Volumes, Timings  
6: Conde Lane & Shiloh Road

2028 Opening Year Alter. C Project Conditions

Timing Plan: A.M. PEAK

												
Lane Group	EBL	EBT	EBR	WBL	WBT	WBR	NBL	NBT	NBR	SBL	SBT	SBR
Lane Configurations												
Traffic Volume (vph)	28	373	6	10	403	232	5	0	14	233	1	40
Future Volume (vph)	28	373	6	10	403	232	5	0	14	233	1	40
Ideal Flow (vphpl)	1900	1900	1900	1900	1900	1900	1900	1900	1900	1900	1900	1900
Storage Length (ft)	90		0	127		0	0		0	0		40
Storage Lanes	1		0	1		0	0		0	0		1
Taper Length (ft)	70			40			25			25		
Lane Util. Factor	1.00	0.95	0.95	1.00	0.95	0.95	1.00	1.00	1.00	1.00	1.00	1.00
Frt		0.998			0.945			0.901				0.850
Flt Protected	0.950			0.950				0.987			0.953	
Satd. Flow (prot)	1770	3532	0	1770	3345	0	0	1657	0	0	1775	1583
Flt Permitted	0.950			0.950				0.987			0.953	
Satd. Flow (perm)	1770	3532	0	1770	3345	0	0	1657	0	0	1775	1583
Right Turn on Red			Yes			Yes			Yes			No
Satd. Flow (RTOR)		2			119			89				
Link Speed (mph)		40			40			30				35
Link Distance (ft)		815			1081			418				522
Travel Time (s)		13.9			18.4			9.5				10.2
Peak Hour Factor	0.95	0.95	0.95	0.85	0.85	0.85	0.57	0.57	0.57	0.86	0.86	0.86
Adj. Flow (vph)	29	393	6	12	474	273	9	0	25	271	1	47
Shared Lane Traffic (%)												
Lane Group Flow (vph)	29	399	0	12	747	0	0	34	0	0	272	47
Enter Blocked Intersection	No	No	No	No	No	No	No	No	No	No	No	No
Lane Alignment	Left	Left	Right	Left	Left	Right	Left	Left	Right	Left	Left	Right
Median Width(ft)		12			12			0				0
Link Offset(ft)		0			0			0				0
Crosswalk Width(ft)		16			16			16				16
Two way Left Turn Lane												
Headway Factor	1.00	1.00	1.00	1.00	1.00	1.00	1.00	1.00	1.00	1.00	1.00	1.00
Turning Speed (mph)	15		9	15		9	15		9	15		9
Number of Detectors	1	2		1	2		1	2		1	1	1
Detector Template	Left	Thru		Left	Thru		Left	Thru		Left	Thru	Right
Leading Detector (ft)	20	100		20	100		20	100		20	30	20
Trailing Detector (ft)	0	0		0	0		0	0		0	0	0
Detector 1 Position(ft)	0	0		0	0		0	0		0	0	0
Detector 1 Size(ft)	20	6		20	6		20	6		20	30	20
Detector 1 Type	Cl+Ex	Cl+Ex		Cl+Ex	Cl+Ex		Cl+Ex	Cl+Ex		Cl+Ex	Cl+Ex	Cl+Ex
Detector 1 Channel												
Detector 1 Extend (s)	0.0	0.0		0.0	0.0		0.0	0.0		0.0	0.0	0.0
Detector 1 Queue (s)	0.0	0.0		0.0	0.0		0.0	0.0		0.0	0.0	0.0
Detector 1 Delay (s)	0.0	0.0		0.0	0.0		0.0	0.0		0.0	0.0	0.0
Detector 2 Position(ft)		94			94			94				
Detector 2 Size(ft)		6			6			6				
Detector 2 Type		Cl+Ex			Cl+Ex			Cl+Ex				
Detector 2 Channel												
Detector 2 Extend (s)		0.0			0.0			0.0				
Turn Type	Prot	NA		Prot	NA		Split	NA		Split	NA	custom
Protected Phases	5	2		1	6		7	7		4	4	
Permitted Phases												6

Lanes, Volumes, Timings  
6: Conde Lane & Shiloh Road

2028 Opening Year Alter. C Project Conditions

Timing Plan: A.M. PEAK

Lane Group	EBL	EBT	EBR	WBL	WBT	WBR	NBL	NBT	NBR	SBL	SBT	SBR
Detector Phase	5	2		1	6		7	7		4	4	6
Switch Phase												
Minimum Initial (s)	8.0	8.0		8.0	8.0		10.0	10.0		11.0	11.0	8.0
Minimum Split (s)	12.0	46.0		12.0	12.0		37.0	37.0		15.0	15.0	12.0
Total Split (s)	13.0	46.0		12.0	45.0		37.0	37.0		15.0	15.0	45.0
Total Split (%)	11.8%	41.8%		10.9%	40.9%		33.6%	33.6%		13.6%	13.6%	40.9%
Maximum Green (s)	9.0	42.0		8.0	41.0		33.0	33.0		11.0	11.0	41.0
Yellow Time (s)	3.0	3.0		3.0	3.0		3.0	3.0		3.0	3.0	3.0
All-Red Time (s)	1.0	1.0		1.0	1.0		1.0	1.0		1.0	1.0	1.0
Lost Time Adjust (s)	0.0	0.0		0.0	0.0		0.0	0.0		0.0	0.0	0.0
Total Lost Time (s)	4.0	4.0		4.0	4.0		4.0	4.0		4.0	4.0	4.0
Lead/Lag	Lead	Lag		Lead	Lag							Lag
Lead-Lag Optimize?	Yes	Yes		Yes	Yes							Yes
Vehicle Extension (s)	3.0	3.0		3.0	3.0		3.0	3.0		3.0	3.0	3.0
Recall Mode	None	None		None	None		None	None		None	None	None
Walk Time (s)		7.0					7.0	7.0				
Flash Don't Walk (s)		35.0					26.0	26.0				
Pedestrian Calls (#/hr)		0					0	0				
Act Effct Green (s)	9.4	19.5		9.3	17.8		11.6	11.6		12.8	12.8	17.8
Actuated g/C Ratio	0.20	0.41		0.20	0.38		0.25	0.25		0.27	0.27	0.38
v/c Ratio	0.08	0.27		0.03	0.56		0.07	0.07		0.56	0.56	0.08
Control Delay (s/veh)	25.4	10.6		25.7	13.0		0.3	0.3		30.1	30.1	13.3
Queue Delay	0.0	0.0		0.0	0.0		0.0	0.0		0.0	0.0	0.0
Total Delay (s/veh)	25.4	10.6		25.7	13.0		0.3	0.3		30.1	30.1	13.3
LOS	C	B		C	B		A	A		C	C	B
Approach Delay (s/veh)		11.6			13.2		0.3	0.3		27.6	27.6	
Approach LOS		B			B		A	A		C	C	

Intersection Summary

Area Type:	Other
Cycle Length:	110
Actuated Cycle Length:	47
Natural Cycle:	110
Control Type:	Actuated-Uncoordinated
Maximum v/c Ratio:	0.56
Intersection Signal Delay (s/veh):	15.4
Intersection LOS:	B
Intersection Capacity Utilization:	49.6%
ICU Level of Service:	A
Analysis Period (min):	15

Splits and Phases: 6: Conde Lane & Shiloh Road



Lanes, Volumes, Timings  
7: Driveway 1/Gridley Drive & Shiloh Road

2028 Opening Year Alter. C Project Conditions  
Timing Plan: A.M. PEAK

Lane Group	EBL	EBT	EBR	WBL	WBT	WBR	NBL	NBT	NBR	SBL	SBT	SBR
Lane Configurations												
Traffic Volume (vph)	9	161	64	5	66	0	42	0	3	1	0	18
Future Volume (vph)	9	161	64	5	66	0	42	0	3	1	0	18
Ideal Flow (vphpl)	1900	1900	1900	1900	1900	1900	1900	1900	1900	1900	1900	1900
Lane Util. Factor	1.00	1.00	1.00	1.00	1.00	1.00	1.00	1.00	1.00	1.00	1.00	1.00
Ped Bike Factor												
Frt	0.963						0.850				0.870	
Flt Protected	0.998				0.996		0.950				0.998	
Satd. Flow (prot)	0	1790	0	0	1855	0	1770	1583	0	0	1617	0
Flt Permitted	0.998				0.996		0.950				0.998	
Satd. Flow (perm)	0	1790	0	0	1855	0	1770	1583	0	0	1617	0
Link Speed (mph)	40				40		30				30	
Link Distance (ft)	608				2146		248				715	
Travel Time (s)	10.4				36.6		5.6				16.3	
Confl. Bikes (#/hr)			1									
Peak Hour Factor	0.91	0.91	0.91	0.85	0.85	0.85	1.00	1.00	1.00	0.71	0.71	0.71
Adj. Flow (vph)	10	177	70	6	78	0	42	0	3	1	0	25
Shared Lane Traffic (%)												
Lane Group Flow (vph)	0	257	0	0	84	0	42	3	0	0	26	0
Enter Blocked Intersection	No	No	No	No	No	No	No	No	No	No	No	No
Lane Alignment	Left	Left	Right	Left	Left	Right	Left	Left	Right	Left	Left	Right
Median Width(ft)	0				0		12				12	
Link Offset(ft)	0				0		0				0	
Crosswalk Width(ft)	16				16		16				16	
Two way Left Turn Lane												
Headway Factor	1.00	1.00	1.00	1.00	1.00	1.00	1.00	1.00	1.00	1.00	1.00	1.00
Turning Speed (mph)	15		9	15		9	15		9	15		9
Sign Control	Free				Free		Stop				Stop	



















Intersection Summary	
Area Type:	Other
Control Type:	Unsignalized
Intersection Capacity Utilization	30.5%
Analysis Period (min)	15
	ICU Level of Service A



Lanes, Volumes, Timings  
8: Old Redwood Hwy & Driveway 2

2028 Opening Year Alter. C Project Conditions

Timing Plan: A.M. PEAK

												
Lane Group	EBL	EBT	EBR	WBL	WBT	WBR	NBL	NBT	NBR	SBL	SBT	SBR
Lane Configurations												
Traffic Volume (vph)	1	0	0	6	0	10	0	247	9	15	360	0
Future Volume (vph)	1	0	0	6	0	10	0	247	9	15	360	0
Ideal Flow (vphp)	1900	1900	1900	1900	1900	1900	1900	1900	1900	1900	1900	1900
Storage Length (ft)	0		0	0		0	0		0	50		0
Storage Lanes	0		0	1		0	0		0	1		0
Taper Length (ft)	25			25			25			25		
Lane Util. Factor	1.00	1.00	1.00	1.00	1.00	1.00	1.00	1.00	1.00	1.00	1.00	1.00
Ped Bike Factor												
Frt					0.850			0.995				
Flt Protected		0.950		0.950						0.950		
Satd. Flow (prot)	0	1770	0	1770	1583	0	0	1853	0	1770	1863	0
Flt Permitted		0.950		0.950						0.950		
Satd. Flow (perm)	0	1770	0	1770	1583	0	0	1853	0	1770	1863	0
Link Speed (mph)		30			30			45			45	
Link Distance (ft)		98			385			520			748	
Travel Time (s)		2.2			8.8			7.9			11.3	
Confl. Peds. (#/hr)									1	1		
Confl. Bikes (#/hr)									1			2
Peak Hour Factor	0.25	0.25	0.25	1.00	1.00	1.00	0.99	0.99	0.99	0.90	0.90	0.90
Adj. Flow (vph)	4	0	0	6	0	10	0	249	9	17	400	0
Shared Lane Traffic (%)												
Lane Group Flow (vph)	0	4	0	6	10	0	0	258	0	17	400	0
Enter Blocked Intersection	No	No	No	No	No	No	No	No	No	No	No	No
Lane Alignment	Left	Left	Right	Left	Left	Right	Left	Left	Right	Left	Left	Right
Median Width(ft)		12			12			12			12	
Link Offset(ft)		0			0			0			0	
Crosswalk Width(ft)		16			16			16			16	
Two way Left Turn Lane												
Headway Factor	1.00	1.00	1.00	1.00	1.00	1.00	1.00	1.00	1.00	1.00	1.00	1.00
Turning Speed (mph)	15		9	15		9	15		9	15		9
Sign Control		Stop			Stop			Free			Free	











Intersection Summary

Area Type:	Other
Control Type:	Unsignalized
Intersection Capacity Utilization	28.9%
Analysis Period (min)	15
	ICU Level of Service A

Lanes, Volumes, Timings  
9: Shiloh Road

2028 Opening Year Alter. C Project Conditions

Timing Plan: A.M. PEAK

						
Lane Group	EBT	EBR	WBL	WBT	NBL	NBR
Lane Configurations						
Traffic Volume (vph)	162	0	0	64	0	0
Future Volume (vph)	162	0	0	64	0	0
Ideal Flow (vphp)	1900	1900	1900	1900	1900	1900
Lane Util. Factor	1.00	1.00	1.00	1.00	1.00	1.00
<b>Fr</b>						
<b>Flt Protected</b>						
Satd. Flow (prot)	1863	0	0	1863	1863	1863
<b>Flt Permitted</b>						
Satd. Flow (perm)	1863	0	0	1863	1863	1863
Link Speed (mph)	40			40	30	
Link Distance (ft)	2146			134	402	
Travel Time (s)	36.6			2.3	9.1	
Peak Hour Factor	0.85	0.85	0.81	0.81	1.00	1.00
Adj. Flow (vph)	191	0	0	79	0	0
<b>Shared Lane Traffic (%)</b>						
Lane Group Flow (vph)	191	0	0	79	0	0
Enter Blocked Intersection	No	No	No	No	No	No
Lane Alignment	Left	Right	Left	Left	Left	Right
Median Width(ft)	0			0	12	
Link Offset(ft)	0			0	0	
Crosswalk Width(ft)	16			16	16	
<b>Two way Left Turn Lane</b>						
Headway Factor	1.00	1.00	1.00	1.00	1.00	1.00
Turning Speed (mph)		9	15		15	9
Sign Control	Free			Free	Stop	
<b>Intersection Summary</b>						
Area Type:	Other					
Control Type:	Unsignalized					
Intersection Capacity Utilization	11.9%			ICU Level of Service A		
Analysis Period (min)	15					

Lanes, Volumes, Timings

2028 Opening Year Alter. C Project Conditions

10: US 101 NB Off Ramp/Lakewood Drive & Old Redwood Highway

Timing Plan: A.M. PEAK



Lane Group	EBL	EBT	EBR	WBL	WBT	WBR	NBL	NBT	NBR	SBL	SBT	SBR
Lane Configurations	↔↔	↑			↑↑		↔	↔↔		↔↔		↔
Traffic Volume (vph)	173	179	0	0	507	170	258	252	90	134	0	608
Future Volume (vph)	173	179	0	0	507	170	258	252	90	134	0	608
Ideal Flow (vphpl)	1900	1900	1900	1900	1900	1900	1900	1900	1900	1900	1900	1900
Storage Length (ft)	155		0	0		0	270		150	120		0
Storage Lanes	1		0	0		0	1		1	1		1
Taper Length (ft)	50			25			165			75		
Lane Util. Factor	0.97	1.00	1.00	1.00	0.95	0.95	0.91	0.91	0.95	0.97	1.00	1.00
Ped Bike Factor	1.00				1.00			1.00		1.00		
Flt					0.962			0.966				0.850
Flt Protected	0.950						0.950	0.993		0.950		
Satd. Flow (prot)	3433	1863	0	0	3393	0	1610	3242	0	3433	0	1583
Flt Permitted	0.950						0.950	0.993		0.950		
Satd. Flow (perm)	3431	1863	0	0	3393	0	1610	3242	0	3427	0	1583
Right Turn on Red			Yes			Yes			Yes			Yes
Satd. Flow (RTOR)					52			41				281
Link Speed (mph)		35			35			30				30
Link Distance (ft)		226			617			716				478
Travel Time (s)		4.4			12.0			16.3				10.9
Confl. Peds. (#/hr)	1		1	1		1			2	2		
Confl. Bikes (#/hr)			1			1						
Peak Hour Factor	0.85	0.85	0.85	0.83	0.83	0.83	0.90	0.90	0.90	0.89	0.89	0.89
Adj. Flow (vph)	204	211	0	0	611	205	287	280	100	151	0	683
Shared Lane Traffic (%)							23%					
Lane Group Flow (vph)	204	211	0	0	816	0	221	446	0	151	0	683
Enter Blocked Intersection	No	No	No	No	No	No	No	No	No	No	No	No
Lane Alignment	Left	Left	Right	Left	Left	Right	Left	Left	Right	Left	Left	Right
Median Width(ft)		24			24			24				24
Link Offset(ft)		0			0			0				0
Crosswalk Width(ft)		16			16			16				16
Two way Left Turn Lane												
Headway Factor	1.00	1.00	1.00	1.00	1.00	1.00	1.00	1.00	1.00	1.00	1.00	1.00
Turning Speed (mph)	15		9	15		9	15		9	15		9
Number of Detectors	1	2			2		1	2		1		1
Detector Template	Left	Thru			Thru		Left	Thru		Left		Right
Leading Detector (ft)	20	100			100		20	100		20		20
Trailing Detector (ft)	0	0			0		0	0		0		0
Detector 1 Position(ft)	0	0			0		0	0		0		0
Detector 1 Size(ft)	20	6			6		20	6		20		20
Detector 1 Type	Cl+Ex	Cl+Ex			Cl+Ex		Cl+Ex	Cl+Ex		Cl+Ex		Cl+Ex
Detector 1 Channel												
Detector 1 Extend (s)	0.0	0.0			0.0		0.0	0.0		0.0		0.0
Detector 1 Queue (s)	0.0	0.0			0.0		0.0	0.0		0.0		0.0
Detector 1 Delay (s)	0.0	0.0			0.0		0.0	0.0		0.0		0.0
Detector 2 Position(ft)		94			94			94				
Detector 2 Size(ft)		6			6			6				
Detector 2 Type		Cl+Ex			Cl+Ex			Cl+Ex				
Detector 2 Channel												
Detector 2 Extend (s)		0.0			0.0			0.0				

Lanes, Volumes, Timings

2028 Opening Year Alter. C Project Conditions

10: US 101 NB Off Ramp/Lakewood Drive & Old Redwood Highway

Timing Plan: A.M. PEAK



Lane Group	EBL	EBT	EBR	WBL	WBT	WBR	NBL	NBT	NBR	SBL	SBT	SBR
Turn Type	Prot	NA			NA		Split	NA		Prot		pm+ov
Protected Phases	5	2			6		8	8		7		5
Permitted Phases												5 8
Detector Phase	5	2			6		8	8		7		5
Switch Phase												
Minimum Initial (s)	7.0	10.0			10.0		10.0	10.0		7.0		7.0
Minimum Split (s)	11.0	32.1			32.1		33.7	33.7		11.0		11.0
Total Split (s)	13.0	45.3			32.3		33.7	33.7		11.0		13.0
Total Split (%)	14.4%	50.3%			35.9%		37.4%	37.4%		12.2%		14.4%
Maximum Green (s)	9.0	40.2			27.2		29.0	29.0		7.0		9.0
Yellow Time (s)	3.0	4.1			4.1		3.7	3.7		3.0		3.0
All-Red Time (s)	1.0	1.0			1.0		1.0	1.0		1.0		1.0
Lost Time Adjust (s)	0.0	0.0			0.0		0.0	0.0		0.0		0.0
Total Lost Time (s)	4.0	5.1			5.1		4.7	4.7		4.0		4.0
Lead/Lag	Lead				Lag		Lag	Lag		Lead		Lead
Lead-Lag Optimize?	Yes				Yes		Yes	Yes		Yes		Yes
Vehicle Extension (s)	3.0	3.0			3.0		3.0	3.0		3.0		3.0
Recall Mode	None	Max			Max		None	None		None		None
Walk Time (s)		7.0			7.0		7.0	7.0				
Flash Don't Walk (s)		20.0			17.0		22.0	22.0				
Pedestrian Calls (#/hr)		0			0		0	0				
Act Effct Green (s)	8.6	40.4			27.7		17.7	17.7		7.0		31.1
Actuated g/C Ratio	0.11	0.51			0.35		0.22	0.22		0.09		0.39
v/c Ratio	0.54	0.22			0.67		0.61	0.59		0.50		0.86
Control Delay (s/veh)	40.3	12.6			24.5		34.9	27.7		41.8		24.8
Queue Delay	0.0	0.0			0.0		0.0	0.0		0.0		0.0
Total Delay (s/veh)	40.3	12.6			24.5		34.9	27.7		41.8		24.8
LOS	D	B			C		C	C		D		C
Approach Delay (s/veh)		26.2			24.5			30.1				27.8
Approach LOS		C			C			C				C

Intersection Summary

Area Type: Other  
 Cycle Length: 90  
 Actuated Cycle Length: 79  
 Natural Cycle: 90  
 Control Type: Actuated-Uncoordinated  
 Maximum v/c Ratio: 0.86  
 Intersection Signal Delay (s/veh): 27.2  
 Intersection LOS: C  
 Intersection Capacity Utilization 81.6%  
 ICU Level of Service D  
 Analysis Period (min) 15

Splits and Phases: 10: US 101 NB Off Ramp/Lakewood Drive & Old Redwood Highway

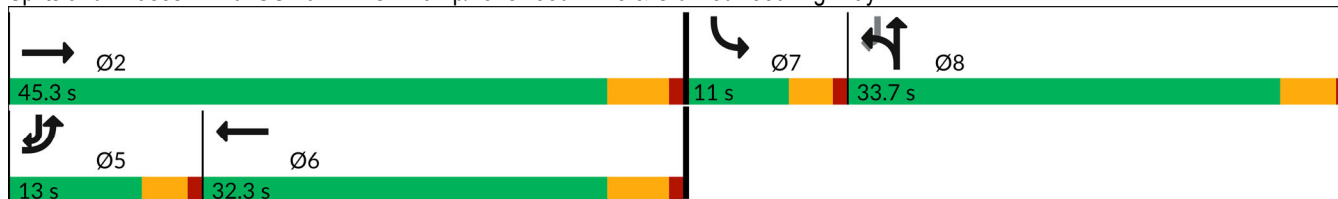

Lanes, Volumes, Timings  
 11: Old Redwood Highway & US 101 NB On Ramp

2028 Opening Year Alter. C Project Conditions

Timing Plan: A.M. PEAK

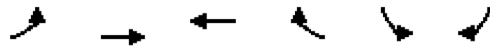

Lane Group	EBL	EBT	WBT	WBR	SBL	SBR
Lane Configurations						
Traffic Volume (vph)	98	349	1152	216	0	0
Future Volume (vph)	98	349	1152	216	0	0
Ideal Flow (vphpl)	1900	1900	1900	1900	1900	1900
Storage Length (ft)	245			0	0	0
Storage Lanes	1			0	0	0
Taper Length (ft)	50				25	
Lane Util. Factor	1.00	0.95	0.95	0.95	1.00	1.00
Ped Bike Factor						
Frt			0.976			
Flt Protected	0.950					
Satd. Flow (prot)	1770	3539	3454	0	0	0
Flt Permitted	0.950					
Satd. Flow (perm)	1770	3539	3454	0	0	0
Link Speed (mph)		35	35		30	
Link Distance (ft)		531	226		299	
Travel Time (s)		10.3	4.4		6.8	
Confl. Peds. (#/hr)	9					
Confl. Bikes (#/hr)				1		
Peak Hour Factor	0.81	0.81	0.89	0.89	0.25	0.25
Adj. Flow (vph)	121	431	1294	243	0	0
Shared Lane Traffic (%)						
Lane Group Flow (vph)	121	431	1537	0	0	0
Enter Blocked Intersection	No	No	No	No	No	No
Lane Alignment	Left	Left	Left	Right	Left	Right
Median Width(ft)		12	12		0	
Link Offset(ft)		0	0		0	
Crosswalk Width(ft)		16	16		16	
Two way Left Turn Lane						
Headway Factor	1.00	1.00	1.00	1.00	1.00	1.00
Turning Speed (mph)	15			9	15	9
Sign Control		Free	Free		Free	

Intersection Summary

Area Type:	Other
Control Type:	Unsignalized
Intersection Capacity Utilization	74.7%
Analysis Period (min)	15
	ICU Level of Service D

Lanes, Volumes, Timings

2028 Opening Year Alter. C Project Conditions

12: US 101 SB On Ramp/US 101 SB Off Ramp & Old Redwood Highway

Timing Plan: A.M. PEAK



Lane Group	EBL	EBT	EBR	WBL	WBT	WBR	NBL	NBT	NBR	SBL	SBT	SBR
Lane Configurations		↑↑	↗	↖	↑↑					↖	↕	
Traffic Volume (vph)	0	339	337	584	574	0	0	0	0	114	1	74
Future Volume (vph)	0	339	337	584	574	0	0	0	0	114	1	74
Ideal Flow (vphpl)	1900	1900	1900	1900	1900	1900	1900	1900	1900	1900	1900	1900
Storage Length (ft)	0		0	250		0	0		0	420		0
Storage Lanes	0		1	0		0	0		0	1		0
Taper Length (ft)	25			165			25			75		
Lane Util. Factor	1.00	0.95	1.00	1.00	0.95	1.00	1.00	1.00	1.00	0.95	0.95	1.00
Ped Bike Factor			0.98	1.00								
Frt			0.850								0.878	
Flt Protected				0.950						0.950	0.991	
Satd. Flow (prot)	0	3539	1583	1770	3539	0	0	0	0	1681	1540	0
Flt Permitted				0.950						0.950	0.991	
Satd. Flow (perm)	0	3539	1558	1767	3539	0	0	0	0	1681	1540	0
Right Turn on Red			Yes			Yes			Yes			Yes
Satd. Flow (RTOR)			350								91	
Link Speed (mph)		35			35			30			30	
Link Distance (ft)		423			531			621			831	
Travel Time (s)		8.2			10.3			14.1			18.9	
Confl. Peds. (#/hr)	10		3	3		10						
Confl. Bikes (#/hr)			2									
Peak Hour Factor	0.92	0.92	0.92	0.89	0.89	0.89	0.25	0.25	0.25	0.81	0.81	0.81
Adj. Flow (vph)	0	368	366	656	645	0	0	0	0	141	1	91
Shared Lane Traffic (%)										14%		
Lane Group Flow (vph)	0	368	366	656	645	0	0	0	0	121	112	0
Enter Blocked Intersection	No	No	No	No	No	No	No	No	No	No	No	No
Lane Alignment	Left	Left	Right	Left	Left	Right	Left	Left	Right	Left	Left	Right
Median Width(ft)		24			24			12			12	
Link Offset(ft)		0			0			0			0	
Crosswalk Width(ft)		16			16			16			16	
Two way Left Turn Lane												
Headway Factor	1.00	1.00	1.00	1.00	1.00	1.00	1.00	1.00	1.00	1.00	1.00	1.00
Turning Speed (mph)	15		9	15		9	15		9	15		9
Number of Detectors		2	1	1	2					1	2	
Detector Template		Thru	Right	Left	Thru					Left	Thru	
Leading Detector (ft)		100	20	20	100					20	100	
Trailing Detector (ft)		0	0	0	0					0	0	
Detector 1 Position(ft)		0	0	0	0					0	0	
Detector 1 Size(ft)		6	20	20	6					20	6	
Detector 1 Type		Cl+Ex	Cl+Ex	Cl+Ex	Cl+Ex					Cl+Ex	Cl+Ex	
Detector 1 Channel												
Detector 1 Extend (s)		0.0	0.0	0.0	0.0					0.0	0.0	
Detector 1 Queue (s)		0.0	0.0	0.0	0.0					0.0	0.0	
Detector 1 Delay (s)		0.0	0.0	0.0	0.0					0.0	0.0	
Detector 2 Position(ft)		94			94							94
Detector 2 Size(ft)		6			6							6
Detector 2 Type		Cl+Ex			Cl+Ex							Cl+Ex
Detector 2 Channel												
Detector 2 Extend (s)		0.0			0.0							0.0

Lanes, Volumes, Timings

2028 Opening Year Alter. C Project Conditions

12: US 101 SB On Ramp/US 101 SB Off Ramp & Old Redwood Highway

Timing Plan: A.M. PEAK



Lane Group	EBL	EBT	EBR	WBL	WBT	WBR	NBL	NBT	NBR	SBL	SBT	SBR
Turn Type		NA	Perm	Prot	NA					Perm	NA	
Protected Phases		6		5	2						8	
Permitted Phases			6							8		
Detector Phase		6	6	5	2					8	8	
Switch Phase												
Minimum Initial (s)		10.0	10.0	7.0	10.0					10.0	10.0	
Minimum Split (s)		32.1	32.1	11.0	38.1					14.7	14.7	
Total Split (s)		32.3	32.3	33.0	65.3					14.7	14.7	
Total Split (%)		40.4%	40.4%	41.3%	81.6%					18.4%	18.4%	
Maximum Green (s)		27.2	27.2	29.0	60.2					10.0	10.0	
Yellow Time (s)		4.1	4.1	3.0	4.1					3.7	3.7	
All-Red Time (s)		1.0	1.0	1.0	1.0					1.0	1.0	
Lost Time Adjust (s)		0.0	0.0	0.0	0.0					0.0	0.0	
Total Lost Time (s)		5.1	5.1	4.0	5.1					4.7	4.7	
Lead/Lag		Lag	Lag	Lead								
Lead-Lag Optimize?		Yes	Yes	Yes								
Vehicle Extension (s)		3.0	3.0	3.0	3.0					3.0	3.0	
Recall Mode		Max	Max	None	Max					None	None	
Walk Time (s)		7.0	7.0		7.0							
Flash Don't Walk (s)		20.0	20.0		25.0							
Pedestrian Calls (#/hr)		0	0		0							
Act Effct Green (s)		27.2	27.2	29.0	60.2					10.0	10.0	
Actuated g/C Ratio		0.34	0.34	0.36	0.75					0.13	0.13	
v/c Ratio		0.31	0.48	1.02	0.24					0.58	0.41	
Control Delay (s/veh)		20.3	5.2	69.4	3.2					45.0	15.7	
Queue Delay		0.0	0.0	0.0	0.0					0.0	0.0	
Total Delay (s/veh)		20.3	5.2	69.4	3.2					45.0	15.7	
LOS		C	A	E	A					D	B	
Approach Delay (s/veh)		12.8			36.6						30.9	
Approach LOS		B			D						C	

Intersection Summary

Area Type: Other

Cycle Length: 80

Actuated Cycle Length: 80

Natural Cycle: 80

Control Type: Actuated-Uncoordinated

Maximum v/c Ratio: 1.02

Intersection Signal Delay (s/veh): 28.3

Intersection LOS: C

Intersection Capacity Utilization 74.7%

ICU Level of Service D

Analysis Period (min) 15



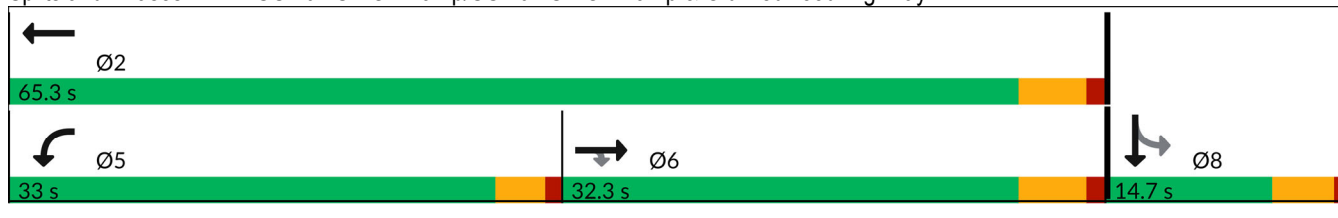



















Splits and Phases: 12: US 101 SB On Ramp/US 101 SB Off Ramp & Old Redwood Highway



Lanes, Volumes, Timings  
1: Old Redwood Hwy & Shiloh Road

2028 Opening Year Alter. C Project Conditions

Timing Plan: P.M. Peak

												
Lane Group	EBL	EBT	EBR	WBL	WBT	WBR	NBL	NBT	NBR	SBL	SBT	SBR
Lane Configurations												
Traffic Volume (vph)	290	161	222	42	150	25	199	388	24	34	271	183
Future Volume (vph)	290	161	222	42	150	25	199	388	24	34	271	183
Ideal Flow (vphpl)	1900	1900	1900	1900	1900	1900	1900	1900	1900	1900	1900	1900
Storage Length (ft)	375		140	0		50	200		98	130		93
Storage Lanes	1		1	0		1	1		1	1		1
Taper Length (ft)	50			25			60			93		
Lane Util. Factor	1.00	1.00	1.00	1.00	1.00	1.00	1.00	1.00	1.00	1.00	1.00	1.00
Ped Bike Factor	1.00					0.98	1.00		0.98			0.97
Frt			0.850			0.850			0.850			0.850
Flt Protected	0.950				0.989		0.950			0.950		
Satd. Flow (prot)	1770	1863	1583	0	1842	1583	1770	1863	1583	1770	1863	1583
Flt Permitted	0.950				0.989		0.950			0.950		
Satd. Flow (perm)	1767	1863	1583	0	1842	1549	1767	1863	1546	1770	1863	1542
Right Turn on Red			Yes			Yes			Yes			Yes
Satd. Flow (RTOR)			229			105			77			115
Link Speed (mph)		40			40			45				40
Link Distance (ft)		1789			608			748				775
Travel Time (s)		30.5			10.4			11.3				13.2
Confl. Peds. (#/hr)	1						1	1				1
Confl. Bikes (#/hr)									3			3
Peak Hour Factor	0.97	0.97	0.97	0.91	0.91	0.91	0.93	0.93	0.93	0.93	0.93	0.93
Adj. Flow (vph)	299	166	229	46	165	27	214	417	26	37	291	197
Shared Lane Traffic (%)												
Lane Group Flow (vph)	299	166	229	0	211	27	214	417	26	37	291	197
Enter Blocked Intersection	No	No	No	No	No	No	No	No	No	No	No	No
Lane Alignment	Left	Left	Right	Left	Left	Right	Left	Left	Right	Left	Left	Right
Median Width(ft)		12			12			12				12
Link Offset(ft)		0			0			0				0
Crosswalk Width(ft)		16			16			16				16
Two way Left Turn Lane												
Headway Factor	1.00	1.00	1.00	1.00	1.00	1.00	1.00	1.00	1.00	1.00	1.00	1.00
Turning Speed (mph)	15		9	15		9	15		9	15		9
Number of Detectors	1	2	1	1	2	1	1	2	1	1	2	1
Detector Template	Left	Thru	Right	Left	Thru	Right	Left	Thru	Right	Left	Thru	Right
Leading Detector (ft)	20	100	20	20	100	20	20	100	20	20	100	20
Trailing Detector (ft)	0	0	0	0	0	0	0	0	0	0	0	0
Detector 1 Position(ft)	0	0	0	0	0	0	0	0	0	0	0	0
Detector 1 Size(ft)	20	6	20	20	6	20	20	6	20	20	6	20
Detector 1 Type	Cl+Ex	Cl+Ex	Cl+Ex	Cl+Ex	Cl+Ex	Cl+Ex	Cl+Ex	Cl+Ex	Cl+Ex	Cl+Ex	Cl+Ex	Cl+Ex
Detector 1 Channel												
Detector 1 Extend (s)	0.0	0.0	0.0	0.0	0.0	0.0	0.0	0.0	0.0	0.0	0.0	0.0
Detector 1 Queue (s)	0.0	0.0	0.0	0.0	0.0	0.0	0.0	0.0	0.0	0.0	0.0	0.0
Detector 1 Delay (s)	0.0	0.0	0.0	0.0	0.0	0.0	0.0	0.0	0.0	0.0	0.0	0.0
Detector 2 Position(ft)		94			94			94				94
Detector 2 Size(ft)		6			6			6				6
Detector 2 Type		Cl+Ex			Cl+Ex			Cl+Ex				Cl+Ex
Detector 2 Channel												
Detector 2 Extend (s)		0.0			0.0			0.0				0.0



Lanes, Volumes, Timings  
1: Old Redwood Hwy & Shiloh Road

2028 Opening Year Alter. C Project Conditions

Timing Plan: P.M. Peak

Lane Group	EBL	EBT	EBR	WBL	WBT	WBR	NBL	NBT	NBR	SBL	SBT	SBR
Turn Type	Split	NA	Perm	Split	NA	Perm	Prot	NA	Perm	Prot	NA	Perm
Protected Phases	2	2		6	6		3	8		7	4	
Permitted Phases			2			6			8			4
Detector Phase	2	2	2	6	6	6	3	8	8	7	4	4
Switch Phase												
Minimum Initial (s)	5.0	5.0	5.0	5.0	5.0	5.0	5.0	5.0	5.0	5.0	5.0	5.0
Minimum Split (s)	34.5	34.5	34.5	42.5	42.5	42.5	8.5	46.5	46.5	8.5	39.5	39.5
Total Split (s)	35.0	35.0	35.0	42.5	42.5	42.5	18.0	48.0	48.0	9.5	39.5	39.5
Total Split (%)	25.9%	25.9%	25.9%	31.5%	31.5%	31.5%	13.3%	35.6%	35.6%	7.0%	29.3%	29.3%
Maximum Green (s)	30.5	30.5	30.5	38.0	38.0	38.0	14.5	43.5	43.5	6.0	35.0	35.0
Yellow Time (s)	3.5	3.5	3.5	3.5	3.5	3.5	3.0	3.5	3.5	3.0	3.5	3.5
All-Red Time (s)	1.0	1.0	1.0	1.0	1.0	1.0	0.5	1.0	1.0	0.5	1.0	1.0
Lost Time Adjust (s)	0.0	0.0	0.0		0.0	0.0	0.0	0.0	0.0	0.0	0.0	0.0
Total Lost Time (s)	4.5	4.5	4.5		4.5	4.5	3.5	4.5	4.5	3.5	4.5	4.5
Lead/Lag	Lead	Lead	Lead	Lag	Lag	Lag	Lead	Lag	Lag	Lead	Lag	Lag
Lead-Lag Optimize?	Yes	Yes	Yes	Yes	Yes	Yes	Yes	Yes	Yes	Yes	Yes	Yes
Vehicle Extension (s)	3.0	3.0	3.0	3.0	3.0	3.0	3.0	3.0	3.0	3.0	3.0	3.0
Recall Mode	None	None	None	None	None	None	None	None	None	None	None	None
Walk Time (s)	7.0	7.0	7.0	7.0	7.0	7.0		7.0	7.0		7.0	7.0
Flash Don't Walk (s)	23.0	23.0	23.0	31.0	31.0	31.0		35.0	35.0		28.0	28.0
Pedestrian Calls (#/hr)	0	0	0	0	0	0		0	0		0	0
Act Effct Green (s)	22.1	22.1	22.1		16.8	16.8	15.1	34.5	34.5	6.1	20.8	20.8
Actuated g/C Ratio	0.24	0.24	0.24		0.18	0.18	0.16	0.37	0.37	0.07	0.22	0.22
v/c Ratio	0.71	0.37	0.41		0.63	0.07	0.74	0.60	0.04	0.32	0.69	0.45
Control Delay (s/veh)	44.0	34.1	7.0		46.4	0.4	58.2	31.4	0.1	56.1	43.8	18.1
Queue Delay	0.0	0.0	0.0		0.0	0.0	0.0	0.0	0.0	0.0	0.0	0.0
Total Delay (s/veh)	44.0	34.1	7.0		46.4	0.4	58.2	31.4	0.1	56.1	43.8	18.1
LOS	D	C	A		D	A	E	C	A	E	D	B
Approach Delay (s/veh)		29.4			41.2			38.9			35.1	
Approach LOS		C			D			D			D	

Intersection Summary

Area Type: Other  
 Cycle Length: 135  
 Actuated Cycle Length: 92.6  
 Natural Cycle: 135  
 Control Type: Actuated-Uncoordinated  
 Maximum v/c Ratio: 0.74  
 Intersection Signal Delay (s/veh): 35.1  
 Intersection LOS: D  
 Intersection Capacity Utilization 67.3%  
 ICU Level of Service C  
 Analysis Period (min) 15



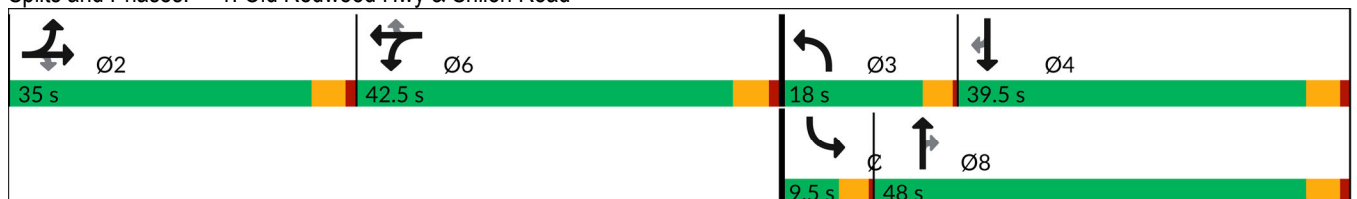

















Splits and Phases: 1: Old Redwood Hwy & Shiloh Road



Lanes, Volumes, Timings  
 2: Shiloh Road & Hembree Ln

2028 Opening Year Alter. C Project Conditions

Timing Plan: P.M. Peak

												
Lane Group	EBL	EBT	EBR	WBL	WBT	WBR	NBL	NBT	NBR	SBL	SBT	SBR
Lane Configurations												
Traffic Volume (vph)	700	512	44	24	395	165	65	11	15	194	11	565
Future Volume (vph)	700	512	44	24	395	165	65	11	15	194	11	565
Ideal Flow (vphpl)	1900	1900	1900	1900	1900	1900	1900	1900	1900	1900	1900	1900
Storage Length (ft)	0		0	100		130	0		0	0		0
Storage Lanes	2		0	1		1	1		0	0		1
Taper Length (ft)	25			50			25			25		
Lane Util. Factor	0.97	1.00	1.00	1.00	0.95	0.95	1.00	1.00	1.00	1.00	1.00	1.00
Ped Bike Factor	1.00				1.00							
Frt		0.989			0.956			0.913				0.850
Flt Protected	0.950			0.950			0.950				0.955	
Satd. Flow (prot)	3433	1842	0	1770	3370	0	1770	1701	0	0	1779	1583
Flt Permitted	0.950			0.950			0.950				0.955	
Satd. Flow (perm)	3430	1842	0	1770	3370	0	1770	1701	0	0	1779	1583
Right Turn on Red			Yes			Yes			Yes			Yes
Satd. Flow (RTOR)		8			95			15				297
Link Speed (mph)		40			40			30				35
Link Distance (ft)		302			1789			216				381
Travel Time (s)		5.1			30.5			4.9				7.4
Confl. Peds. (#/hr)	2						2					
Peak Hour Factor	0.94	0.94	1.00	1.00	0.87	0.87	1.00	1.00	1.00	0.95	1.00	0.95
Adj. Flow (vph)	745	545	44	24	454	190	65	11	15	204	11	595
Shared Lane Traffic (%)												
Lane Group Flow (vph)	745	589	0	24	644	0	65	26	0	0	215	595
Enter Blocked Intersection	No	No	No	No	No	No	No	No	No	No	No	No
Lane Alignment	Left	Left	Right	Left	Left	Right	Left	Left	Right	Left	Left	Right
Median Width(ft)		24			24			12				12
Link Offset(ft)		0			0			0				0
Crosswalk Width(ft)		16			16			16				16
Two way Left Turn Lane												
Headway Factor	1.00	1.00	1.00	1.00	1.00	1.00	1.00	1.00	1.00	1.00	1.00	1.00
Turning Speed (mph)	15		60	60		9	60		60	15		9
Number of Detectors	1	2		1	2		1	2		1	2	1
Detector Template	Left	Thru		Left	Thru		Left	Thru		Left	Thru	Right
Leading Detector (ft)	20	100		20	100		20	100		20	100	20
Trailing Detector (ft)	0	0		0	0		0	0		0	0	0
Detector 1 Position(ft)	0	0		0	0		0	0		0	0	0
Detector 1 Size(ft)	20	6		20	6		20	6		20	6	20
Detector 1 Type	Cl+Ex	Cl+Ex		Cl+Ex	Cl+Ex		Cl+Ex	Cl+Ex		Cl+Ex	Cl+Ex	Cl+Ex
Detector 1 Channel												
Detector 1 Extend (s)	0.0	0.0		0.0	0.0		0.0	0.0		0.0	0.0	0.0
Detector 1 Queue (s)	0.0	0.0		0.0	0.0		0.0	0.0		0.0	0.0	0.0
Detector 1 Delay (s)	0.0	0.0		0.0	0.0		0.0	0.0		0.0	0.0	0.0
Detector 2 Position(ft)		94			94			94				94
Detector 2 Size(ft)		6			6			6				6
Detector 2 Type		Cl+Ex			Cl+Ex			Cl+Ex				Cl+Ex
Detector 2 Channel												
Detector 2 Extend (s)		0.0			0.0			0.0				0.0
Turn Type	Prot	NA		Prot	NA		Split	NA		Split	NA	pt+ov

Lanes, Volumes, Timings  
2: Shiloh Road & Hembree Ln

2028 Opening Year Alter. C Project Conditions

Timing Plan: P.M. Peak

Lane Group	EBL	EBT	EBR	WBL	WBT	WBR	NBL	NBT	NBR	SBL	SBT	SBR
Protected Phases	5	2		1	6		8	8		4	4	4 5
Permitted Phases												
Detector Phase	5	2		1	6		8	8		4	4	4 5
Switch Phase												
Minimum Initial (s)	3.0	5.0		5.0	5.0		5.0	5.0		5.0	5.0	
Minimum Split (s)	7.5	9.5		9.5	43.5		9.5	9.5		9.5	9.5	
Total Split (s)	21.0	57.0		9.5	45.5		9.5	9.5		14.0	14.0	
Total Split (%)	23.3%	63.3%		10.6%	50.6%		10.6%	10.6%		15.6%	15.6%	
Maximum Green (s)	17.0	53.0		5.5	41.5		5.5	5.5		10.0	10.0	
Yellow Time (s)	3.0	3.0		3.0	3.0		3.0	3.0		3.0	3.0	
All-Red Time (s)	1.0	1.0		1.0	1.0		1.0	1.0		1.0	1.0	
Lost Time Adjust (s)	0.0	0.0		0.0	0.0		0.0	0.0		0.0	0.0	
Total Lost Time (s)	4.0	4.0		4.0	4.0		4.0	4.0		4.0	4.0	
Lead/Lag	Lead	Lag		Lead	Lag							
Lead-Lag Optimize?	Yes	Yes		Yes	Yes							
Vehicle Extension (s)	3.0	3.0		3.0	3.0		3.0	3.0		3.0	3.0	
Recall Mode	None	None		None	None		None	None		None	None	
Walk Time (s)					7.0							
Flash Don't Walk (s)					32.0							
Pedestrian Calls (#/hr)					1							
Act Effct Green (s)	17.6	37.5		5.7	19.1		5.7	5.7		10.3	29.0	
Actuated g/C Ratio	0.26	0.56		0.09	0.29		0.09	0.09		0.15	0.43	
v/c Ratio	0.82	0.57		0.16	0.62		0.43	0.16		0.78	0.70	
Control Delay (s/veh)	35.6	13.2		36.2	19.7		43.9	24.9		53.0	13.0	
Queue Delay	0.0	0.0		0.0	0.0		0.0	0.0		0.0	0.0	
Total Delay (s/veh)	35.6	13.2		36.2	19.7		43.9	24.9		53.0	13.0	
LOS	D	B		D	B		D	C		D	B	
Approach Delay (s/veh)		25.7			20.3			38.5			23.6	
Approach LOS		C			C			D			C	

Intersection Summary

Area Type:	Other
Cycle Length:	90
Actuated Cycle Length:	66.7
Natural Cycle:	90
Control Type:	Actuated-Uncoordinated
Maximum v/c Ratio:	0.82
Intersection Signal Delay (s/veh):	24.3
Intersection LOS:	C
Intersection Capacity Utilization:	66.5%
ICU Level of Service:	C
Analysis Period (min):	15

Splits and Phases: 2: Shiloh Road & Hembree Ln



Lanes, Volumes, Timings  
3: US 101 NB Off-Ramp & Shiloh Road

2028 Opening Year Alter. C Project Conditions

Timing Plan: P.M. Peak

	→	↘	↙	←	↖	↗
Lane Group	EBT	EBR	WBL	WBT	NBL	NBR
Lane Configurations	↑↑			↑	↘	↗
Traffic Volume (vph)	466	0	0	716	599	795
Future Volume (vph)	466	0	0	716	599	795
Ideal Flow (vphpl)	1900	1900	1900	1900	1900	1900
Storage Length (ft)		0	0		0	265
Storage Lanes		0	0		1	2
Taper Length (ft)			25		25	
Lane Util. Factor	0.95	1.00	1.00	1.00	1.00	0.88
Frt						0.850
Flt Protected					0.950	
Satd. Flow (prot)	3539	0	0	1863	1770	2787
Flt Permitted					0.950	
Satd. Flow (perm)	3539	0	0	1863	1770	2787
Right Turn on Red		Yes				Yes
Satd. Flow (RTOR)						470
Link Speed (mph)	40			40	30	
Link Distance (ft)	186			371	769	
Travel Time (s)	3.2			6.3	17.5	
Peak Hour Factor	0.94	0.94	0.97	0.97	0.90	0.90
Adj. Flow (vph)	496	0	0	738	666	883
Shared Lane Traffic (%)						
Lane Group Flow (vph)	496	0	0	738	666	883
Enter Blocked Intersection	No	No	No	No	No	No
Lane Alignment	Left	Right	Left	Left	Left	Right
Median Width(ft)	0			0	12	
Link Offset(ft)	0			0	0	
Crosswalk Width(ft)	16			16	16	
Two way Left Turn Lane						
Headway Factor	1.00	1.00	1.00	1.00	1.00	1.00
Turning Speed (mph)		9	15		15	9
Number of Detectors	2			2	1	1
Detector Template	Thru			Thru	Left	Right
Leading Detector (ft)	100			100	20	20
Trailing Detector (ft)	0			0	0	0
Detector 1 Position(ft)	0			0	0	0
Detector 1 Size(ft)	6			6	20	20
Detector 1 Type	Cl+Ex			Cl+Ex	Cl+Ex	Cl+Ex
Detector 1 Channel						
Detector 1 Extend (s)	0.0			0.0	0.0	0.0
Detector 1 Queue (s)	0.0			0.0	0.0	0.0
Detector 1 Delay (s)	0.0			0.0	0.0	0.0
Detector 2 Position(ft)	94			94		
Detector 2 Size(ft)	6			6		
Detector 2 Type	Cl+Ex			Cl+Ex		
Detector 2 Channel						
Detector 2 Extend (s)	0.0			0.0		
Turn Type	NA			NA	Prot	Perm
Protected Phases	2			6	8	
Permitted Phases						8

Lanes, Volumes, Timings  
 3: US 101 NB Off-Ramp & Shiloh Road

2028 Opening Year Alter. C Project Conditions  
 Timing Plan: P.M. Peak



Lane Group	EBT	EBR	WBL	WBT	NBL	NBR
Detector Phase	2			6	8	8
Switch Phase						
Minimum Initial (s)	5.0			5.0	5.0	5.0
Minimum Split (s)	9.0			9.0	9.0	9.0
Total Split (s)	37.0			37.0	35.0	35.0
Total Split (%)	51.4%			51.4%	48.6%	48.6%
Maximum Green (s)	33.0			33.0	31.0	31.0
Yellow Time (s)	3.0			3.0	3.0	3.0
All-Red Time (s)	1.0			1.0	1.0	1.0
Lost Time Adjust (s)	0.0			0.0	0.0	0.0
Total Lost Time (s)	4.0			4.0	4.0	4.0
Lead/Lag						
Lead-Lag Optimize?						
Vehicle Extension (s)	3.0			3.0	3.0	3.0
Recall Mode	None			None	None	None
Act Effect Green (s)	29.7			29.7	28.8	28.8
Actuated g/C Ratio	0.45			0.45	0.43	0.43
v/c Ratio	0.31			0.89	0.87	0.60
Control Delay (s/veh)	12.8			32.7	32.8	8.6
Queue Delay	0.0			0.0	0.0	0.0
Total Delay (s/veh)	12.8			32.7	32.8	8.6
LOS	B			C	C	A
Approach Delay (s/veh)	12.8			32.7	19.0	
Approach LOS	B			C	B	

Intersection Summary

Area Type: Other  
 Cycle Length: 72  
 Actuated Cycle Length: 66.7  
 Natural Cycle: 65  
 Control Type: Actuated-Uncoordinated  
 Maximum v/c Ratio: 0.89  
 Intersection Signal Delay (s/veh): 21.5      Intersection LOS: C  
 Intersection Capacity Utilization 118.9%      ICU Level of Service H  
 Analysis Period (min) 15

Splits and Phases: 3: US 101 NB Off-Ramp & Shiloh Road

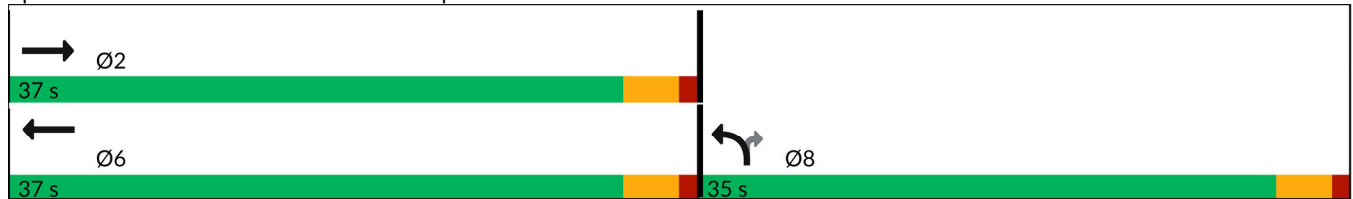

Lanes, Volumes, Timings  
4: Shiloh Road & US 101 SB Off-Ramp

2028 Opening Year Alter. C Project Conditions

Timing Plan: P.M. Peak

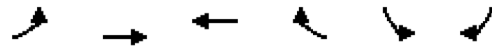

Lane Group	EBL	EBT	WBT	WBR	SBL	SBR
Lane Configurations		↑	↑		↘	↗
Traffic Volume (vph)	0	503	719	0	166	146
Future Volume (vph)	0	503	719	0	166	146
Ideal Flow (vphp)	1900	1900	1900	1900	1900	1900
Storage Length (ft)	0			0	0	275
Storage Lanes	0			0	1	1
Taper Length (ft)	25				25	
Lane Util. Factor	1.00	1.00	1.00	1.00	1.00	1.00
Ped Bike Factor						0.98
Frt						0.850
Flt Protected					0.950	
Satd. Flow (prot)	0	1863	1863	0	1770	1583
Flt Permitted					0.950	
Satd. Flow (perm)	0	1863	1863	0	1770	1548
Right Turn on Red				Yes		Yes
Satd. Flow (RTOR)						157
Link Speed (mph)		40	40		30	
Link Distance (ft)		225	306		486	
Travel Time (s)		3.8	5.2		11.0	
Confl. Peds. (#/hr)						1
Peak Hour Factor	0.89	0.89	0.96	0.96	0.93	0.93
Adj. Flow (vph)	0	565	749	0	178	157
Shared Lane Traffic (%)						
Lane Group Flow (vph)	0	565	749	0	178	157
Enter Blocked Intersection	No	No	No	No	No	No
Lane Alignment	Left	Left	Left	Right	Left	Right
Median Width(ft)		4	0		12	
Link Offset(ft)		0	0		0	
Crosswalk Width(ft)		16	16		16	
Two way Left Turn Lane						
Headway Factor	1.00	1.00	1.00	1.00	1.00	1.00
Turning Speed (mph)	15			9	15	9
Number of Detectors		2	2		1	1
Detector Template		Thru	Thru		Left	Right
Leading Detector (ft)		100	100		20	20
Trailing Detector (ft)		0	0		0	0
Detector 1 Position(ft)		0	0		0	0
Detector 1 Size(ft)		6	6		20	20
Detector 1 Type		Cl+Ex	Cl+Ex		Cl+Ex	Cl+Ex
Detector 1 Channel						
Detector 1 Extend (s)		0.0	0.0		0.0	0.0
Detector 1 Queue (s)		0.0	0.0		0.0	0.0
Detector 1 Delay (s)		0.0	0.0		0.0	0.0
Detector 2 Position(ft)		94	94			
Detector 2 Size(ft)		6	6			
Detector 2 Type		Cl+Ex	Cl+Ex			
Detector 2 Channel						
Detector 2 Extend (s)		0.0	0.0			
Turn Type		NA	NA		Perm	Perm

Lanes, Volumes, Timings  
4: Shiloh Road & US 101 SB Off-Ramp

2028 Opening Year Alter. C Project Conditions

Timing Plan: P.M. Peak



Lane Group	EBL	EBT	WBT	WBR	SBL	SBR
Protected Phases		2	6			
Permitted Phases					4	4
Detector Phase		2	6		4	4
Switch Phase						
Minimum Initial (s)		5.0	5.0		5.0	5.0
Minimum Split (s)		9.0	38.0		9.0	9.0
Total Split (s)		69.0	69.0		21.0	21.0
Total Split (%)		76.7%	76.7%		23.3%	23.3%
Maximum Green (s)		65.0	65.0		17.0	17.0
Yellow Time (s)		3.0	3.0		3.0	3.0
All-Red Time (s)		1.0	1.0		1.0	1.0
Lost Time Adjust (s)		0.0	0.0		0.0	0.0
Total Lost Time (s)		4.0	4.0		4.0	4.0
Lead/Lag						
Lead-Lag Optimize?						
Vehicle Extension (s)		3.0	3.0		3.0	3.0
Recall Mode		None	None		None	None
Walk Time (s)			7.0			
Flash Don't Walk (s)			27.0			
Pedestrian Calls (#/hr)			0			
Act Effct Green (s)		24.0	24.0		10.1	10.1
Actuated g/C Ratio		0.56	0.56		0.24	0.24
v/c Ratio		0.54	0.71		0.43	0.32
Control Delay (s/veh)		7.9	11.2		20.0	6.1
Queue Delay		0.0	0.0		0.0	0.0
Total Delay (s/veh)		7.9	11.2		20.0	6.1
LOS		A	B		B	A
Approach Delay (s/veh)		7.9	11.2		13.4	
Approach LOS		A	B		B	

Intersection Summary

Area Type:	Other
Cycle Length:	90
Actuated Cycle Length:	42.7
Natural Cycle:	50
Control Type:	Actuated-Uncoordinated
Maximum v/c Ratio:	0.71
Intersection Signal Delay (s/veh):	10.6
Intersection LOS:	B
Intersection Capacity Utilization:	70.2%
ICU Level of Service:	C
Analysis Period (min):	15

Splits and Phases: 4: Shiloh Road & US 101 SB Off-Ramp

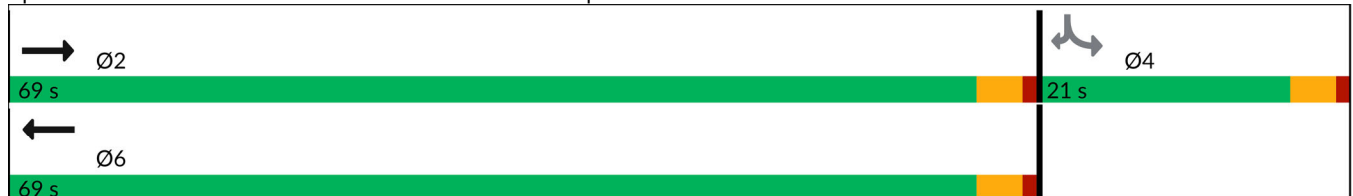

Lanes, Volumes, Timings  
5: Caletti Ave & Shiloh Road

2028 Opening Year Alter. C Project Conditions

Timing Plan: P.M. Peak

	→	↘	↙	←	↖	↗
Lane Group	EBT	EBR	WBL	WBT	NBL	NBR
Lane Configurations	↑↑		↙	↑	↘	↗
Traffic Volume (vph)	974	32	90	746	17	170
Future Volume (vph)	974	32	90	746	17	170
Ideal Flow (vphpl)	1900	1900	1900	1900	1900	1900
Storage Length (ft)		0	68		0	0
Storage Lanes		0	1		1	1
Taper Length (ft)			50		25	
Lane Util. Factor	0.95	0.95	1.00	1.00	1.00	1.00
Frt	0.995					0.850
Flt Protected			0.950		0.950	
Satd. Flow (prot)	3522	0	1770	1863	1770	1583
Flt Permitted			0.950		0.950	
Satd. Flow (perm)	3522	0	1770	1863	1770	1583
Link Speed (mph)	40			40	30	
Link Distance (ft)	1081			184	459	
Travel Time (s)	18.4			3.1	10.4	
Peak Hour Factor	0.89	0.89	0.92	0.92	0.89	0.89
Adj. Flow (vph)	1094	36	98	811	19	191
Shared Lane Traffic (%)						
Lane Group Flow (vph)	1130	0	98	811	19	191
Enter Blocked Intersection	No	No	No	No	No	No
Lane Alignment	Left	Right	Left	Left	Left	Right
Median Width(ft)	12			12	12	
Link Offset(ft)	0			0	0	
Crosswalk Width(ft)	16			16	16	
Two way Left Turn Lane						
Headway Factor	1.00	1.00	1.00	1.00	1.00	1.00
Turning Speed (mph)		9	15		15	9
Sign Control	Free			Free	Stop	
<b>Intersection Summary</b>						
Area Type:	Other					
Control Type:	Unsignalized					
Intersection Capacity Utilization	49.3%			ICU Level of Service A		
Analysis Period (min)	15					



Lanes, Volumes, Timings  
6: Conde Lane & Shiloh Road

2028 Opening Year Alter. C Project Conditions

Timing Plan: P.M. Peak

Lane Group	EBL	EBT	EBR	WBL	WBT	WBR	NBL	NBT	NBR	SBL	SBT	SBR
Lane Configurations												
Traffic Volume (vph)	79	540	2	8	524	329	6	3	19	338	0	44
Future Volume (vph)	79	540	2	8	524	329	6	3	19	338	0	44
Ideal Flow (vphpl)	1900	1900	1900	1900	1900	1900	1900	1900	1900	1900	1900	1900
Storage Length (ft)	90		0	127		0	0		0	0		40
Storage Lanes	1		0	1		0	0		0	0		1
Taper Length (ft)	70			40			25			25		
Lane Util. Factor	1.00	0.95	0.95	1.00	0.95	0.95	1.00	1.00	1.00	1.00	1.00	1.00
Ped Bike Factor	1.00				0.99							
Frt					0.942			0.910				0.850
Flt Protected	0.950			0.950				0.989			0.950	
Satd. Flow (prot)	1770	3539	0	1770	3307	0	0	1676	0	0	1770	1583
Flt Permitted	0.950			0.950				0.989			0.950	
Satd. Flow (perm)	1767	3539	0	1770	3307	0	0	1676	0	0	1770	1583
Right Turn on Red			Yes			Yes			Yes			No
Satd. Flow (RTOR)					143			30				
Link Speed (mph)		40			40			30				35
Link Distance (ft)		815			1081			418				522
Travel Time (s)		13.9			18.4			9.5				10.2
Confl. Peds. (#/hr)	1						1					
Peak Hour Factor	0.88	0.88	0.88	0.80	0.80	0.80	0.63	0.63	0.63	0.88	0.88	0.88
Adj. Flow (vph)	90	614	2	10	655	411	10	5	30	384	0	50
Shared Lane Traffic (%)												
Lane Group Flow (vph)	90	616	0	10	1066	0	0	45	0	0	384	50
Enter Blocked Intersection	No	No	No	No	No	No	No	No	No	No	No	No
Lane Alignment	Left	Left	Right	Left	Left	Right	Left	Left	Right	Left	Left	Right
Median Width(ft)		12			12			0				0
Link Offset(ft)		0			0			0				0
Crosswalk Width(ft)		16			16			16				16
Two way Left Turn Lane												
Headway Factor	1.00	1.00	1.00	1.00	1.00	1.00	1.00	1.00	1.00	1.00	1.00	1.00
Turning Speed (mph)	15		9	15		9	15		9	15		9
Number of Detectors	1	2		1	2		1	2		1	1	1
Detector Template	Left	Thru		Left	Thru		Left	Thru		Left	Thru	Right
Leading Detector (ft)	20	100		20	100		20	100		20	30	20
Trailing Detector (ft)	0	0		0	0		0	0		0	0	0
Detector 1 Position(ft)	0	0		0	0		0	0		0	0	0
Detector 1 Size(ft)	20	6		20	6		20	6		20	30	20
Detector 1 Type	Cl+Ex	Cl+Ex		Cl+Ex	Cl+Ex		Cl+Ex	Cl+Ex		Cl+Ex	Cl+Ex	Cl+Ex
Detector 1 Channel												
Detector 1 Extend (s)	0.0	0.0		0.0	0.0		0.0	0.0		0.0	0.0	0.0
Detector 1 Queue (s)	0.0	0.0		0.0	0.0		0.0	0.0		0.0	0.0	0.0
Detector 1 Delay (s)	0.0	0.0		0.0	0.0		0.0	0.0		0.0	0.0	0.0
Detector 2 Position(ft)		94			94			94				
Detector 2 Size(ft)		6			6			6				
Detector 2 Type		Cl+Ex			Cl+Ex			Cl+Ex				
Detector 2 Channel												
Detector 2 Extend (s)		0.0			0.0			0.0				
Turn Type	Prot	NA		Prot	NA		Split	NA		Split	NA	custom

Lanes, Volumes, Timings  
6: Conde Lane & Shiloh Road

2028 Opening Year Alter. C Project Conditions

Timing Plan: P.M. Peak

Lane Group	EBL	EBT	EBR	WBL	WBT	WBR	NBL	NBT	NBR	SBL	SBT	SBR
Protected Phases	5	2		1	6		7	7		4	4	
Permitted Phases												6
Detector Phase	5	2		1	6		7	7		4	4	6
Switch Phase												
Minimum Initial (s)	8.0	8.0		8.0	8.0		10.0	10.0		11.0	11.0	8.0
Minimum Split (s)	12.0	46.0		12.0	12.0		37.0	37.0		15.0	15.0	12.0
Total Split (s)	13.0	46.0		12.0	45.0		37.0	37.0		15.0	15.0	45.0
Total Split (%)	11.8%	41.8%		10.9%	40.9%		33.6%	33.6%		13.6%	13.6%	40.9%
Maximum Green (s)	9.0	42.0		8.0	41.0		33.0	33.0		11.0	11.0	41.0
Yellow Time (s)	3.0	3.0		3.0	3.0		3.0	3.0		3.0	3.0	3.0
All-Red Time (s)	1.0	1.0		1.0	1.0		1.0	1.0		1.0	1.0	1.0
Lost Time Adjust (s)	0.0	0.0		0.0	0.0		0.0	0.0		0.0	0.0	0.0
Total Lost Time (s)	4.0	4.0		4.0	4.0		4.0	4.0		4.0	4.0	4.0
Lead/Lag	Lead	Lag		Lead	Lag							Lag
Lead-Lag Optimize?	Yes	Yes		Yes	Yes							Yes
Vehicle Extension (s)	3.0	3.0		3.0	3.0		3.0	3.0		3.0	3.0	3.0
Recall Mode	None	None		None	None		None	None		None	None	None
Walk Time (s)		7.0					7.0	7.0				
Flash Don't Walk (s)		35.0					26.0	26.0				
Pedestrian Calls (#/hr)		0					0	0				
Act Effct Green (s)	9.6	34.8		9.1	27.3		11.4			12.5		27.3
Actuated g/C Ratio	0.15	0.53		0.14	0.42		0.18			0.19		0.42
v/c Ratio	0.34	0.33		0.04	0.73		0.14			1.13		0.08
Control Delay (s/veh)	36.8	9.9		34.6	17.7		18.9			122.5		13.6
Queue Delay	0.0	0.0		0.0	0.0		0.0			0.0		0.0
Total Delay (s/veh)	36.8	9.9		34.6	17.7		18.9			122.5		13.6
LOS	D	A		C	B		B			F		B
Approach Delay (s/veh)		13.3			17.9		18.9			110.0		
Approach LOS		B			B		B			F		

Intersection Summary

















Area Type:	Other
Cycle Length:	110
Actuated Cycle Length:	65.1
Natural Cycle:	120
Control Type:	Actuated-Uncoordinated
Maximum v/c Ratio:	1.13
Intersection Signal Delay (s/veh):	34.1
Intersection LOS:	C
Intersection Capacity Utilization:	67.1%
ICU Level of Service:	C
Analysis Period (min):	15

Splits and Phases: 6: Conde Lane & Shiloh Road



Lanes, Volumes, Timings  
7: Driveway 1/Gridley Drive & Shiloh Road

2028 Opening Year Alter. C Project Conditions  
Timing Plan: P.M. Peak



















												
Lane Group	EBL	EBT	EBR	WBL	WBT	WBR	NBL	NBT	NBR	SBL	SBT	SBR
Lane Configurations												
Traffic Volume (vph)	19	117	70	5	142	0	66	0	5	0	0	16
Future Volume (vph)	19	117	70	5	142	0	66	0	5	0	0	16
Ideal Flow (vphpl)	1900	1900	1900	1900	1900	1900	1900	1900	1900	1900	1900	1900
Lane Util. Factor	1.00	1.00	1.00	1.00	1.00	1.00	1.00	1.00	1.00	1.00	1.00	1.00
Ped Bike Factor												
Frt		0.954						0.850			0.865	
Flt Protected		0.995			0.998		0.950					
Satd. Flow (prot)	0	1768	0	0	1859	0	1770	1583	0	0	1611	0
Flt Permitted		0.995			0.998		0.950					
Satd. Flow (perm)	0	1768	0	0	1859	0	1770	1583	0	0	1611	0
Link Speed (mph)		40			40			30			30	
Link Distance (ft)		608			2146			248			715	
Travel Time (s)		10.4			36.6			5.6			16.3	
Confl. Peds. (#/hr)	1											
Confl. Bikes (#/hr)			1									
Peak Hour Factor	0.94	0.94	0.94	0.69	0.69	0.69	1.00	1.00	1.00	0.58	0.58	0.58
Adj. Flow (vph)	20	124	74	7	206	0	66	0	5	0	0	28
Shared Lane Traffic (%)												
Lane Group Flow (vph)	0	218	0	0	213	0	66	5	0	0	28	0
Enter Blocked Intersection	No	No	No	No	No	No	No	No	No	No	No	No
Lane Alignment	Left	Left	Right	Left	Left	Right	Left	Left	Right	Left	Left	Right
Median Width(ft)		0			0			12			12	
Link Offset(ft)		0			0			0			0	
Crosswalk Width(ft)		16			16			16			16	
Two way Left Turn Lane												
Headway Factor	1.00	1.00	1.00	1.00	1.00	1.00	1.00	1.00	1.00	1.00	1.00	1.00
Turning Speed (mph)	15		9	15		9	15		9	15		9
Sign Control		Free			Free			Stop			Stop	

Intersection Summary												
Area Type:	Other											
Control Type:	Unsignalized											
Intersection Capacity Utilization	36.0%					ICU Level of Service A						
Analysis Period (min)	15											

Lanes, Volumes, Timings  
8: Old Redwood Hwy & Driveway 2

2028 Opening Year Alter. C Project Conditions

Timing Plan: P.M. Peak

												
Lane Group	EBL	EBT	EBR	WBL	WBT	WBR	NBL	NBT	NBR	SBL	SBT	SBR
Lane Configurations												
Traffic Volume (vph)	3	0	0	9	0	15	0	575	10	16	486	0
Future Volume (vph)	3	0	0	9	0	15	0	575	10	16	486	0
Ideal Flow (vphp)	1900	1900	1900	1900	1900	1900	1900	1900	1900	1900	1900	1900
Storage Length (ft)	0		0	0		0	0		0	50		0
Storage Lanes	0		0	1		0	0		0	1		0
Taper Length (ft)	25			25			25			25		
Lane Util. Factor	1.00	1.00	1.00	1.00	1.00	1.00	1.00	1.00	1.00	1.00	1.00	1.00
Ped Bike Factor												
Frt					0.850			0.998				
Flt Protected		0.950		0.950						0.950		
Satd. Flow (prot)	0	1770	0	1770	1583	0	0	1859	0	1770	1863	0
Flt Permitted		0.950		0.950						0.950		
Satd. Flow (perm)	0	1770	0	1770	1583	0	0	1859	0	1770	1863	0
Link Speed (mph)		30			30			45			45	
Link Distance (ft)		98			385			520			748	
Travel Time (s)		2.2			8.8			7.9			11.3	
Confl. Bikes (#/hr)									3			5
Peak Hour Factor	0.38	0.38	0.38	1.00	1.00	1.00	0.91	0.91	0.91	0.94	0.94	0.94
Adj. Flow (vph)	8	0	0	9	0	15	0	632	11	17	517	0
Shared Lane Traffic (%)												
Lane Group Flow (vph)	0	8	0	9	15	0	0	643	0	17	517	0
Enter Blocked Intersection	No	No	No	No	No	No	No	No	No	No	No	No
Lane Alignment	Left	Left	Right	Left	Left	Right	Left	Left	Right	Left	Left	Right
Median Width(ft)		12			12			12			12	
Link Offset(ft)		0			0			0			0	
Crosswalk Width(ft)		16			16			16			16	
Two way Left Turn Lane												
Headway Factor	1.00	1.00	1.00	1.00	1.00	1.00	1.00	1.00	1.00	1.00	1.00	1.00
Turning Speed (mph)	15		9	15		9	15		9	15		9
Sign Control		Stop			Stop			Free			Free	

Intersection Summary

Area Type:	Other
Control Type:	Unsignalized
Intersection Capacity Utilization	40.9%
ICU Level of Service	A
Analysis Period (min)	15

Lanes, Volumes, Timings  
9: Shiloh Road

2028 Opening Year Alter. C Project Conditions

Timing Plan: P.M. Peak

	→	↘	↙	←	↖	↗
Lane Group	EBT	EBR	WBL	WBT	NBL	NBR
Lane Configurations	↗			↖	↘	↗
Traffic Volume (vph)	97	0	0	131	0	0
Future Volume (vph)	97	0	0	131	0	0
Ideal Flow (vphp)	1900	1900	1900	1900	1900	1900
Lane Util. Factor	1.00	1.00	1.00	1.00	1.00	1.00
<b>Fr</b>						
Flt Protected						
Satd. Flow (prot)	1863	0	0	1863	1863	1863
Flt Permitted						
Satd. Flow (perm)	1863	0	0	1863	1863	1863
Link Speed (mph)	40			40	30	
Link Distance (ft)	2146			134	402	
Travel Time (s)	36.6			2.3	9.1	
Peak Hour Factor	0.92	0.92	0.68	0.68	1.00	1.00
Adj. Flow (vph)	105	0	0	193	0	0
Shared Lane Traffic (%)						
Lane Group Flow (vph)	105	0	0	193	0	0
Enter Blocked Intersection	No	No	No	No	No	No
Lane Alignment	Left	Right	Left	Left	Left	Right
Median Width(ft)	0			0	12	
Link Offset(ft)	0			0	0	
Crosswalk Width(ft)	16			16	16	
Two way Left Turn Lane						
Headway Factor	1.00	1.00	1.00	1.00	1.00	1.00
Turning Speed (mph)		9	15		15	9
Sign Control	Free			Free	Stop	
<b>Intersection Summary</b>						
Area Type:	Other					
Control Type:	Unsignalized					
Intersection Capacity Utilization	10.2%			ICU Level of Service A		
Analysis Period (min)	15					

Lanes, Volumes, Timings

2028 Opening Year Alter. C Project Conditions

10: US 101 NB Off Ramp/Lakewood Drive & Old Redwood Highway

Timing Plan: P.M. Peak



Lane Group	EBL	EBT	EBR	WBL	WBT	WBR	NBL	NBT	NBR	SBL	SBT	SBR
Lane Configurations												
Traffic Volume (vph)	297	409	0	0	575	219	569	469	286	284	0	657
Future Volume (vph)	297	409	0	0	575	219	569	469	286	284	0	657
Ideal Flow (vphpl)	1900	1900	1900	1900	1900	1900	1900	1900	1900	1900	1900	1900
Storage Length (ft)	155		0	0		0	270		150	120		0
Storage Lanes	1		0	0		0	1		1	1		1
Taper Length (ft)	50			25			165			75		
Lane Util. Factor	0.97	1.00	1.00	1.00	0.95	0.95	0.91	0.91	0.95	0.97	1.00	1.00
Ped Bike Factor	1.00				0.99			0.99		1.00		
Flt					0.959			0.951				0.850
Flt Protected	0.950						0.950	0.993		0.950		
Satd. Flow (prot)	3433	1863	0	0	3374	0	1610	3181	0	3433	0	1583
Flt Permitted	0.950						0.950	0.993		0.950		
Satd. Flow (perm)	3427	1863	0	0	3374	0	1610	3181	0	3422	0	1583
Right Turn on Red			Yes			Yes			Yes			Yes
Satd. Flow (RTOR)					63			85				275
Link Speed (mph)		35			35			30				30
Link Distance (ft)		226			617			716				478
Travel Time (s)		4.4			12.0			16.3				10.9
Confl. Peds. (#/hr)	3		1	1		3			8	8		
Confl. Bikes (#/hr)			2			9						
Peak Hour Factor	0.87	0.87	0.87	0.91	0.91	0.91	0.92	0.92	0.92	0.96	0.96	0.96
Adj. Flow (vph)	341	470	0	0	632	241	618	510	311	296	0	684
Shared Lane Traffic (%)							22%					
Lane Group Flow (vph)	341	470	0	0	873	0	482	957	0	296	0	684
Enter Blocked Intersection	No	No	No	No	No	No	No	No	No	No	No	No
Lane Alignment	Left	Left	Right	Left	Left	Right	Left	Left	Right	Left	Left	Right
Median Width(ft)		24			24			24				24
Link Offset(ft)		0			0			0				0
Crosswalk Width(ft)		16			16			16				16
Two way Left Turn Lane												
Headway Factor	1.00	1.00	1.00	1.00	1.00	1.00	1.00	1.00	1.00	1.00	1.00	1.00
Turning Speed (mph)	15		9	15		9	15		9	15		9
Number of Detectors	1	2			2		1	2		1		1
Detector Template	Left	Thru			Thru		Left	Thru		Left		Right
Leading Detector (ft)	20	100			100		20	100		20		20
Trailing Detector (ft)	0	0			0		0	0		0		0
Detector 1 Position(ft)	0	0			0		0	0		0		0
Detector 1 Size(ft)	20	6			6		20	6		20		20
Detector 1 Type	Cl+Ex	Cl+Ex			Cl+Ex		Cl+Ex	Cl+Ex		Cl+Ex		Cl+Ex
Detector 1 Channel												
Detector 1 Extend (s)	0.0	0.0			0.0		0.0	0.0		0.0		0.0
Detector 1 Queue (s)	0.0	0.0			0.0		0.0	0.0		0.0		0.0
Detector 1 Delay (s)	0.0	0.0			0.0		0.0	0.0		0.0		0.0
Detector 2 Position(ft)		94			94			94				
Detector 2 Size(ft)		6			6			6				
Detector 2 Type		Cl+Ex			Cl+Ex			Cl+Ex				
Detector 2 Channel												
Detector 2 Extend (s)		0.0			0.0			0.0				

Lanes, Volumes, Timings

2028 Opening Year Alter. C Project Conditions

10: US 101 NB Off Ramp/Lakewood Drive & Old Redwood Highway

Timing Plan: P.M. Peak



Lane Group	EBL	EBT	EBR	WBL	WBT	WBR	NBL	NBT	NBR	SBL	SBT	SBR
Turn Type	Prot	NA			NA		Split	NA		Prot		pm+ov
Protected Phases	5	2			6		8	8		7		5
Permitted Phases												5 8
Detector Phase	5	2			6		8	8		7		5
Switch Phase												
Minimum Initial (s)	7.0	10.0			10.0		10.0	10.0		7.0		7.0
Minimum Split (s)	11.0	32.1			32.1		33.7	33.7		11.0		11.0
Total Split (s)	13.0	45.3			32.3		33.7	33.7		11.0		13.0
Total Split (%)	14.4%	50.3%			35.9%		37.4%	37.4%		12.2%		14.4%
Maximum Green (s)	9.0	40.2			27.2		29.0	29.0		7.0		9.0
Yellow Time (s)	3.0	4.1			4.1		3.7	3.7		3.0		3.0
All-Red Time (s)	1.0	1.0			1.0		1.0	1.0		1.0		1.0
Lost Time Adjust (s)	0.0	0.0			0.0		0.0	0.0		0.0		0.0
Total Lost Time (s)	4.0	5.1			5.1		4.7	4.7		4.0		4.0
Lead/Lag	Lead				Lag		Lag	Lag		Lead		Lead
Lead-Lag Optimize?	Yes				Yes		Yes	Yes		Yes		Yes
Vehicle Extension (s)	3.0	3.0			3.0		3.0	3.0		3.0		3.0
Recall Mode	None	Max			Max		None	None		None		None
Walk Time (s)		7.0			7.0		7.0	7.0				
Flash Don't Walk (s)		20.0			17.0		22.0	22.0				
Pedestrian Calls (#/hr)		0			0		0	0				
Act Effct Green (s)	9.0	40.2			27.2		29.0	29.0		7.0		42.7
Actuated g/C Ratio	0.10	0.45			0.30		0.32	0.32		0.08		0.47
v/c Ratio	0.99	0.56			0.82		0.93	0.88		1.11		0.76
Control Delay (s/veh)	89.6	21.7			34.7		56.9	37.7		127.8		17.9
Queue Delay	0.0	0.0			0.0		0.0	0.0		0.0		0.0
Total Delay (s/veh)	89.6	21.7			34.7		56.9	37.7		127.8		17.9
LOS	F	C			C		E	D		F		B
Approach Delay (s/veh)		50.3			34.7			44.1				51.1
Approach LOS		D			C			D				D

Intersection Summary

Area Type: Other  
 Cycle Length: 90  
 Actuated Cycle Length: 90  
 Natural Cycle: 90  
 Control Type: Actuated-Uncoordinated  
 Maximum v/c Ratio: 1.11  
 Intersection Signal Delay (s/veh): 45.0  
 Intersection LOS: D  
 Intersection Capacity Utilization 101.1%  
 ICU Level of Service G  
 Analysis Period (min) 15

Splits and Phases: 10: US 101 NB Off Ramp/Lakewood Drive & Old Redwood Highway

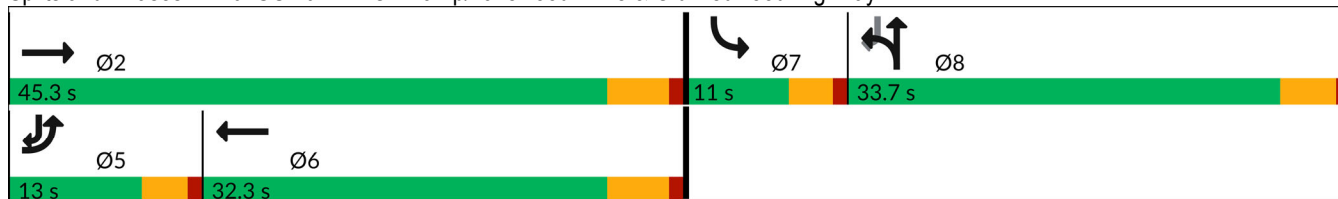

Lanes, Volumes, Timings  
 11: Old Redwood Highway & US 101 NB On Ramp

2028 Opening Year Alter. C Project Conditions

Timing Plan: P.M. Peak



Lane Group	EBL	EBT	WBT	WBR	SBL	SBR
Lane Configurations						
Traffic Volume (vph)	121	699	1598	192	0	0
Future Volume (vph)	121	699	1598	192	0	0
Ideal Flow (vphpl)	1900	1900	1900	1900	1900	1900
Storage Length (ft)	245			0	0	0
Storage Lanes	1			0	0	0
Taper Length (ft)	50				25	
Lane Util. Factor	1.00	0.95	0.95	0.95	1.00	1.00
Ped Bike Factor						
Frt			0.984			
Flt Protected	0.950					
Satd. Flow (prot)	1770	3539	3483	0	0	0
Flt Permitted	0.950					
Satd. Flow (perm)	1770	3539	3483	0	0	0
Link Speed (mph)		35	35		30	
Link Distance (ft)		531	226		299	
Travel Time (s)		10.3	4.4		6.8	
Confl. Peds. (#/hr)	17			17		
Confl. Bikes (#/hr)				8		
Peak Hour Factor	0.85	0.85	0.91	0.91	0.25	0.25
Adj. Flow (vph)	142	822	1756	211	0	0
Shared Lane Traffic (%)						
Lane Group Flow (vph)	142	822	1967	0	0	0
Enter Blocked Intersection	No	No	No	No	No	No
Lane Alignment	Left	Left	Left	Right	Left	Right
Median Width(ft)		12	12		0	
Link Offset(ft)		0	0		0	
Crosswalk Width(ft)		16	16		16	
Two way Left Turn Lane						
Headway Factor	1.00	1.00	1.00	1.00	1.00	1.00
Turning Speed (mph)	15			9	15	9
Sign Control		Free	Free		Free	

Intersection Summary

Area Type:	Other
Control Type:	Unsignalized
Intersection Capacity Utilization	72.7%
Analysis Period (min)	15
	ICU Level of Service C



Lanes, Volumes, Timings

2028 Opening Year Alter. C Project Conditions

12: US 101 SB On Ramp/US 101 SB Off Ramp & Old Redwood Highway

Timing Plan: P.M. Peak



Lane Group	EBL	EBT	EBR	WBL	WBT	WBR	NBL	NBT	NBR	SBL	SBT	SBR
Lane Configurations		↑↑	↗	↖	↑↑					↘	↕	
Traffic Volume (vph)	0	609	434	434	1166	0	0	0	0	200	0	147
Future Volume (vph)	0	609	434	434	1166	0	0	0	0	200	0	147
Ideal Flow (vphpl)	1900	1900	1900	1900	1900	1900	1900	1900	1900	1900	1900	1900
Storage Length (ft)	0		0	250		0	0		0	420		0
Storage Lanes	0		1	0		0	0		0	1		0
Taper Length (ft)	25			165			25			75		
Lane Util. Factor	1.00	0.95	1.00	1.00	0.95	1.00	1.00	1.00	1.00	0.95	0.95	1.00
Ped Bike Factor			0.98	1.00								
Frt			0.850								0.868	
Flt Protected				0.950						0.950	0.994	
Satd. Flow (prot)	0	3539	1583	1770	3539	0	0	0	0	1681	1527	0
Flt Permitted				0.950						0.950	0.994	
Satd. Flow (perm)	0	3539	1558	1768	3539	0	0	0	0	1681	1527	0
Right Turn on Red			Yes			Yes			Yes			Yes
Satd. Flow (RTOR)			453								95	
Link Speed (mph)		35			35			30			30	
Link Distance (ft)		423			531			621			831	
Travel Time (s)		8.2			10.3			14.1			18.9	
Confl. Peds. (#/hr)	19		2	2		18						
Confl. Bikes (#/hr)			4			2						
Peak Hour Factor	0.94	0.94	0.94	0.89	0.89	0.89	0.25	0.25	0.25	0.83	0.83	0.83
Adj. Flow (vph)	0	648	462	488	1310	0	0	0	0	241	0	177
Shared Lane Traffic (%)										10%		
Lane Group Flow (vph)	0	648	462	488	1310	0	0	0	0	217	201	0
Enter Blocked Intersection	No	No	No	No	No	No	No	No	No	No	No	No
Lane Alignment	Left	Left	Right	Left	Left	Right	Left	Left	Right	Left	Left	Right
Median Width(ft)		24			24			12			12	
Link Offset(ft)		0			0			0			0	
Crosswalk Width(ft)		16			16			16			16	
Two way Left Turn Lane												
Headway Factor	1.00	1.00	1.00	1.00	1.00	1.00	1.00	1.00	1.00	1.00	1.00	1.00
Turning Speed (mph)	15		9	15		9	15		9	15		9
Number of Detectors		2	1	1	2					1	2	
Detector Template		Thru	Right	Left	Thru					Left	Thru	
Leading Detector (ft)		100	20	20	100					20	100	
Trailing Detector (ft)		0	0	0	0					0	0	
Detector 1 Position(ft)		0	0	0	0					0	0	
Detector 1 Size(ft)		6	20	20	6					20	6	
Detector 1 Type		Cl+Ex	Cl+Ex	Cl+Ex	Cl+Ex					Cl+Ex	Cl+Ex	
Detector 1 Channel												
Detector 1 Extend (s)		0.0	0.0	0.0	0.0					0.0	0.0	
Detector 1 Queue (s)		0.0	0.0	0.0	0.0					0.0	0.0	
Detector 1 Delay (s)		0.0	0.0	0.0	0.0					0.0	0.0	
Detector 2 Position(ft)		94			94							94
Detector 2 Size(ft)		6			6							6
Detector 2 Type		Cl+Ex			Cl+Ex							Cl+Ex
Detector 2 Channel												
Detector 2 Extend (s)		0.0			0.0							0.0

Lanes, Volumes, Timings

2028 Opening Year Alter. C Project Conditions

12: US 101 SB On Ramp/US 101 SB Off Ramp & Old Redwood Highway

Timing Plan: P.M. Peak



Lane Group	EBL	EBT	EBR	WBL	WBT	WBR	NBL	NBT	NBR	SBL	SBT	SBR
Turn Type		NA	Perm	Prot	NA					Perm	NA	
Protected Phases		6		5	2						8	
Permitted Phases			6							8		
Detector Phase		6	6	5	2					8	8	
Switch Phase												
Minimum Initial (s)		10.0	10.0	7.0	10.0					10.0	10.0	
Minimum Split (s)		32.1	32.1	11.0	38.1					14.7	14.7	
Total Split (s)		33.0	33.0	22.0	55.0					15.0	15.0	
Total Split (%)		47.1%	47.1%	31.4%	78.6%					21.4%	21.4%	
Maximum Green (s)		27.9	27.9	18.0	49.9					10.3	10.3	
Yellow Time (s)		4.1	4.1	3.0	4.1					3.7	3.7	
All-Red Time (s)		1.0	1.0	1.0	1.0					1.0	1.0	
Lost Time Adjust (s)		0.0	0.0	0.0	0.0					0.0	0.0	
Total Lost Time (s)		5.1	5.1	4.0	5.1					4.7	4.7	
Lead/Lag		Lag	Lag	Lead								
Lead-Lag Optimize?		Yes	Yes	Yes								
Vehicle Extension (s)		3.0	3.0	3.0	3.0					3.0	3.0	
Recall Mode		Max	Max	None	Max					None	None	
Walk Time (s)		7.0	7.0		7.0							
Flash Don't Walk (s)		20.0	20.0		25.0							
Pedestrian Calls (#/hr)		0	0		0							
Act Effct Green (s)		27.9	27.9	18.0	49.9					10.3	10.3	
Actuated g/C Ratio		0.40	0.40	0.26	0.71					0.15	0.15	
v/c Ratio		0.46	0.52	1.07	0.52					0.88	0.66	
Control Delay (s/veh)		16.8	4.1	91.7	5.5					65.7	27.3	
Queue Delay		0.0	0.0	0.0	0.0					0.0	0.0	
Total Delay (s/veh)		16.8	4.1	91.7	5.5					65.7	27.3	
LOS		B	A	F	A					E	C	
Approach Delay (s/veh)		11.5			28.9						47.2	
Approach LOS		B			C						D	

Intersection Summary

Area Type: Other  
 Cycle Length: 70  
 Actuated Cycle Length: 70  
 Natural Cycle: 80  
 Control Type: Actuated-Uncoordinated  
 Maximum v/c Ratio: 1.07  
 Intersection Signal Delay (s/veh): 25.4  
 Intersection LOS: C  
 Intersection Capacity Utilization 72.7%  
 ICU Level of Service C  
 Analysis Period (min) 15



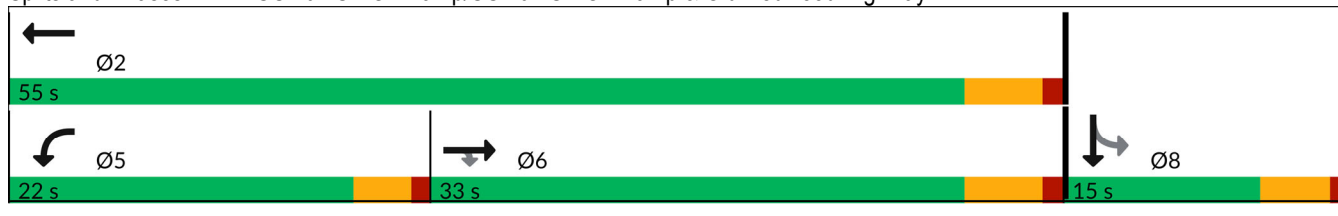



















Splits and Phases: 12: US 101 SB On Ramp/US 101 SB Off Ramp & Old Redwood Highway



Lanes, Volumes, Timings  
 1: Old Redwood Hwy & Shiloh Road

2028 Opening Year Alter. C Project Conditions

Timing Plan: Saturday Midday Peak

												
Lane Group	EBL	EBT	EBR	WBL	WBT	WBR	NBL	NBT	NBR	SBL	SBT	SBR
Lane Configurations												
Traffic Volume (vph)	156	187	221	24	200	32	227	270	27	37	219	239
Future Volume (vph)	156	187	221	24	200	32	227	270	27	37	219	239
Ideal Flow (vphpl)	1900	1900	1900	1900	1900	1900	1900	1900	1900	1900	1900	1900
Storage Length (ft)	375		140	0		50	200		98	130		93
Storage Lanes	1		1	0		1	1		1	1		1
Taper Length (ft)	50			25			60			93		
Lane Util. Factor	1.00	1.00	1.00	1.00	1.00	1.00	1.00	1.00	1.00	1.00	1.00	1.00
Ped Bike Factor	1.00		0.98						0.98			0.97
Frt			0.850			0.850			0.850			0.850
Flt Protected	0.950				0.995		0.950			0.950		
Satd. Flow (prot)	1770	1863	1583	0	1853	1583	1770	1863	1583	1770	1863	1583
Flt Permitted	0.950				0.995		0.950			0.950		
Satd. Flow (perm)	1761	1863	1549	0	1853	1583	1770	1863	1550	1770	1863	1540
Right Turn on Red			Yes			Yes			Yes			Yes
Satd. Flow (RTOR)			248			113			81			185
Link Speed (mph)		40			40			45				40
Link Distance (ft)		1789			608			748				775
Travel Time (s)		30.5			10.4			11.3				13.2
Confl. Peds. (#/hr)	4											
Confl. Bikes (#/hr)			1						1			5
Peak Hour Factor	0.89	0.89	0.89	0.86	0.86	0.86	0.93	0.93	0.93	0.91	0.91	0.91
Adj. Flow (vph)	175	210	248	28	233	37	244	290	29	41	241	263
Shared Lane Traffic (%)												
Lane Group Flow (vph)	175	210	248	0	261	37	244	290	29	41	241	263
Enter Blocked Intersection	No	No	No	No	No	No	No	No	No	No	No	No
Lane Alignment	Left	Left	Right	Left	Left	Right	Left	Left	Right	Left	Left	Right
Median Width(ft)		12			12			12				12
Link Offset(ft)		0			0			0				0
Crosswalk Width(ft)		16			16			16				16
Two way Left Turn Lane												
Headway Factor	1.00	1.00	1.00	1.00	1.00	1.00	1.00	1.00	1.00	1.00	1.00	1.00
Turning Speed (mph)	15		9	15		9	15		9	15		9
Number of Detectors	1	2	1	1	2	1	1	2	1	1	2	1
Detector Template	Left	Thru	Right	Left	Thru	Right	Left	Thru	Right	Left	Thru	Right
Leading Detector (ft)	20	100	20	20	100	20	20	100	20	20	100	20
Trailing Detector (ft)	0	0	0	0	0	0	0	0	0	0	0	0
Detector 1 Position(ft)	0	0	0	0	0	0	0	0	0	0	0	0
Detector 1 Size(ft)	20	6	20	20	6	20	20	6	20	20	6	20
Detector 1 Type	Cl+Ex	Cl+Ex	Cl+Ex	Cl+Ex	Cl+Ex	Cl+Ex	Cl+Ex	Cl+Ex	Cl+Ex	Cl+Ex	Cl+Ex	Cl+Ex
Detector 1 Channel												
Detector 1 Extend (s)	0.0	0.0	0.0	0.0	0.0	0.0	0.0	0.0	0.0	0.0	0.0	0.0
Detector 1 Queue (s)	0.0	0.0	0.0	0.0	0.0	0.0	0.0	0.0	0.0	0.0	0.0	0.0
Detector 1 Delay (s)	0.0	0.0	0.0	0.0	0.0	0.0	0.0	0.0	0.0	0.0	0.0	0.0
Detector 2 Position(ft)		94			94			94				94
Detector 2 Size(ft)		6			6			6				6
Detector 2 Type		Cl+Ex			Cl+Ex			Cl+Ex				Cl+Ex
Detector 2 Channel												
Detector 2 Extend (s)		0.0			0.0			0.0				0.0

Lanes, Volumes, Timings  
1: Old Redwood Hwy & Shiloh Road

2028 Opening Year Alter. C Project Conditions

Timing Plan: Saturday Midday Peak

Lane Group	EBL	EBT	EBR	WBL	WBT	WBR	NBL	NBT	NBR	SBL	SBT	SBR
Turn Type	Split	NA	Perm	Split	NA	Perm	Prot	NA	Perm	Prot	NA	Perm
Protected Phases	2	2		6	6		3	8		7	4	
Permitted Phases			2			6			8			4
Detector Phase	2	2	2	6	6	6	3	8	8	7	4	4
Switch Phase												
Minimum Initial (s)	5.0	5.0	5.0	5.0	5.0	5.0	5.0	5.0	5.0	5.0	5.0	5.0
Minimum Split (s)	34.5	34.5	34.5	42.5	42.5	42.5	9.0	46.5	46.5	9.0	39.5	39.5
Total Split (s)	35.0	35.0	35.0	42.5	42.5	42.5	18.0	48.0	48.0	9.5	39.5	39.5
Total Split (%)	25.9%	25.9%	25.9%	31.5%	31.5%	31.5%	13.3%	35.6%	35.6%	7.0%	29.3%	29.3%
Maximum Green (s)	30.5	30.5	30.5	38.0	38.0	38.0	14.0	43.5	43.5	5.5	35.0	35.0
Yellow Time (s)	3.5	3.5	3.5	3.5	3.5	3.5	3.5	3.5	3.5	3.5	3.5	3.5
All-Red Time (s)	1.0	1.0	1.0	1.0	1.0	1.0	0.5	1.0	1.0	0.5	1.0	1.0
Lost Time Adjust (s)	0.0	0.0	0.0		0.0	0.0	0.0	0.0	0.0	0.0	0.0	0.0
Total Lost Time (s)	4.5	4.5	4.5		4.5	4.5	4.0	4.5	4.5	4.0	4.5	4.5
Lead/Lag	Lead	Lead	Lead	Lag	Lag	Lag	Lead	Lag	Lag	Lead	Lag	Lag
Lead-Lag Optimize?	Yes	Yes	Yes	Yes	Yes	Yes	Yes	Yes	Yes	Yes	Yes	Yes
Vehicle Extension (s)	3.0	3.0	3.0	3.0	3.0	3.0	3.0	3.0	3.0	3.0	3.0	3.0
Recall Mode	None	None	None	None	None	None	None	None	None	None	None	None
Walk Time (s)	7.0	7.0	7.0	7.0	7.0	7.0		7.0	7.0		7.0	7.0
Flash Don't Walk (s)	23.0	23.0	23.0	31.0	31.0	31.0		35.0	35.0		28.0	28.0
Pedestrian Calls (#/hr)	0	0	0	0	0	0		0	0		0	0
Act Effct Green (s)	16.6	16.6	16.6		18.2	18.2	14.6	31.2	31.2	5.7	17.4	17.4
Actuated g/C Ratio	0.19	0.19	0.19		0.21	0.21	0.17	0.37	0.37	0.07	0.20	0.20
v/c Ratio	0.51	0.58	0.50		0.66	0.09	0.81	0.43	0.05	0.34	0.63	0.57
Control Delay (s/veh)	38.2	39.8	8.3		41.1	0.4	59.5	26.7	0.1	53.6	40.8	16.2
Queue Delay	0.0	0.0	0.0		0.0	0.0	0.0	0.0	0.0	0.0	0.0	0.0
Total Delay (s/veh)	38.2	39.8	8.3		41.1	0.4	59.5	26.7	0.1	53.6	40.8	16.2
LOS	D	D	A		D	A	E	C	A	D	D	B
Approach Delay (s/veh)		27.0			36.0			39.6			29.9	
Approach LOS		C			D			D			C	

Intersection Summary

Area Type: Other  
 Cycle Length: 135  
 Actuated Cycle Length: 85.2  
 Natural Cycle: 135  
 Control Type: Actuated-Uncoordinated  
 Maximum v/c Ratio: 0.81  
 Intersection Signal Delay (s/veh): 32.6  
 Intersection LOS: C  
 Intersection Capacity Utilization 60.4%  
 ICU Level of Service B  
 Analysis Period (min) 15



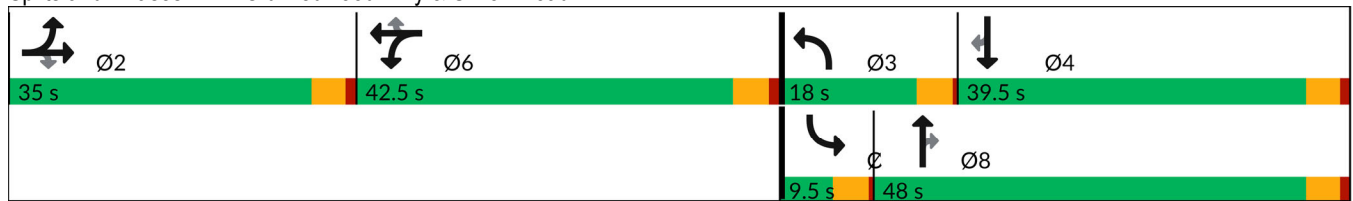



























Splits and Phases: 1: Old Redwood Hwy & Shiloh Road



Lanes, Volumes, Timings  
2: Shiloh Road & Hembree Ln

2028 Opening Year Alter. C Project Conditions

Timing Plan: Saturday Midday Peak

												
Lane Group	EBL	EBT	EBR	WBL	WBT	WBR	NBL	NBT	NBR	SBL	SBT	SBR
Lane Configurations	 	 		 	 		 	 		 	 	 
Traffic Volume (vph)	708	487	44	24	423	185	65	11	15	182	11	666
Future Volume (vph)	708	487	44	24	423	185	65	11	15	182	11	666
Ideal Flow (vphpl)	1900	1900	1900	1900	1900	1900	1900	1900	1900	1900	1900	1900
Storage Length (ft)	0		0	100		130	0		0	0		0
Storage Lanes	2		0	1		1	1		0	0		1
Taper Length (ft)	25			50			25			25		
Lane Util. Factor	0.97	1.00	1.00	1.00	0.95	0.95	1.00	1.00	1.00	1.00	1.00	1.00
Ped Bike Factor	1.00				1.00							
Frt		0.988			0.954			0.913				0.850
Flt Protected	0.950			0.950			0.950				0.955	
Satd. Flow (prot)	3433	1840	0	1770	3363	0	1770	1701	0	0	1779	1583
Flt Permitted	0.950			0.950			0.950				0.955	
Satd. Flow (perm)	3431	1840	0	1770	3363	0	1770	1701	0	0	1779	1583
Right Turn on Red			Yes			Yes			Yes			Yes
Satd. Flow (RTOR)		8			102			15				309
Link Speed (mph)		40			40			30				35
Link Distance (ft)		302			1789			216				381
Travel Time (s)		5.1			30.5			4.9				7.4
Confl. Peds. (#/hr)	1						1					
Peak Hour Factor	0.94	0.94	1.00	1.00	0.96	0.96	1.00	1.00	1.00	0.91	1.00	0.91
Adj. Flow (vph)	753	518	44	24	441	193	65	11	15	200	11	732
Shared Lane Traffic (%)												
Lane Group Flow (vph)	753	562	0	24	634	0	65	26	0	0	211	732
Enter Blocked Intersection	No	No	No	No	No	No	No	No	No	No	No	No
Lane Alignment	Left	Left	Right	Left	Left	Right	Left	Left	Right	Left	Left	Right
Median Width(ft)		24			24			12				12
Link Offset(ft)		0			0			0				0
Crosswalk Width(ft)		16			16			16				16
Two way Left Turn Lane												
Headway Factor	1.00	1.00	1.00	1.00	1.00	1.00	1.00	1.00	1.00	1.00	1.00	1.00
Turning Speed (mph)	15		9	15		9	15		9	15		9
Number of Detectors	1	2		1	2		1	2		1	2	1
Detector Template	Left	Thru		Left	Thru		Left	Thru		Left	Thru	Right
Leading Detector (ft)	20	100		20	100		20	100		20	100	20
Trailing Detector (ft)	0	0		0	0		0	0		0	0	0
Detector 1 Position(ft)	0	0		0	0		0	0		0	0	0
Detector 1 Size(ft)	20	6		20	6		20	6		20	6	20
Detector 1 Type	Cl+Ex	Cl+Ex		Cl+Ex	Cl+Ex		Cl+Ex	Cl+Ex		Cl+Ex	Cl+Ex	Cl+Ex
Detector 1 Channel												
Detector 1 Extend (s)	0.0	0.0		0.0	0.0		0.0	0.0		0.0	0.0	0.0
Detector 1 Queue (s)	0.0	0.0		0.0	0.0		0.0	0.0		0.0	0.0	0.0
Detector 1 Delay (s)	0.0	0.0		0.0	0.0		0.0	0.0		0.0	0.0	0.0
Detector 2 Position(ft)		94			94			94				94
Detector 2 Size(ft)		6			6			6				6
Detector 2 Type		Cl+Ex			Cl+Ex			Cl+Ex				Cl+Ex
Detector 2 Channel												
Detector 2 Extend (s)		0.0			0.0			0.0				0.0
Turn Type	Prot	NA		Prot	NA		Split	NA		Split	NA	pt+ov

Lanes, Volumes, Timings  
2: Shiloh Road & Hembree Ln

2028 Opening Year Alter. C Project Conditions

Timing Plan: Saturday Midday Peak

Lane Group	EBL	EBT	EBR	WBL	WBT	WBR	NBL	NBT	NBR	SBL	SBT	SBR
Protected Phases	5	2		1	6		8	8		4	4	4 5
Permitted Phases												
Detector Phase	5	2		1	6		8	8		4	4	4 5
Switch Phase												
Minimum Initial (s)	3.0	5.0		5.0	5.0		5.0	5.0		5.0	5.0	
Minimum Split (s)	7.5	9.5		9.5	43.5		9.5	9.5		9.5	9.5	
Total Split (s)	21.0	57.0		9.5	45.5		9.5	9.5		14.0	14.0	
Total Split (%)	23.3%	63.3%		10.6%	50.6%		10.6%	10.6%		15.6%	15.6%	
Maximum Green (s)	17.0	53.0		5.5	41.5		5.5	5.5		10.0	10.0	
Yellow Time (s)	3.0	3.0		3.0	3.0		3.0	3.0		3.0	3.0	
All-Red Time (s)	1.0	1.0		1.0	1.0		1.0	1.0		1.0	1.0	
Lost Time Adjust (s)	0.0	0.0		0.0	0.0		0.0	0.0		0.0	0.0	
Total Lost Time (s)	4.0	4.0		4.0	4.0		4.0	4.0		4.0	4.0	
Lead/Lag	Lead	Lag		Lead	Lag							
Lead-Lag Optimize?	Yes	Yes		Yes	Yes							
Vehicle Extension (s)	3.0	3.0		3.0	3.0		3.0	3.0		3.0	3.0	
Recall Mode	None	None		None	None		None	None		None	None	
Walk Time (s)					7.0							
Flash Don't Walk (s)					32.0							
Pedestrian Calls (#/hr)					1							
Act Effct Green (s)	17.6	39.0		5.7	18.7		5.7	5.7		10.3	29.0	
Actuated g/C Ratio	0.27	0.59		0.09	0.28		0.09	0.09		0.16	0.44	
v/c Ratio	0.83	0.52		0.16	0.62		0.43	0.16		0.76	0.85	
Control Delay (s/veh)	35.5	10.9		35.9	19.5		43.4	24.7		50.5	21.3	
Queue Delay	0.0	0.0		0.0	0.0		0.0	0.0		0.0	0.0	
Total Delay (s/veh)	35.5	10.9		35.9	19.5		43.4	24.7		50.5	21.3	
LOS	D	B		D	B		D	C		D	C	
Approach Delay (s/veh)		25.0			20.1			38.1			27.8	
Approach LOS		C			C			D			C	

Intersection Summary

Area Type:	Other
Cycle Length:	90
Actuated Cycle Length:	66.3
Natural Cycle:	100
Control Type:	Actuated-Uncoordinated
Maximum v/c Ratio:	0.85
Intersection Signal Delay (s/veh):	25.2
Intersection LOS:	C
Intersection Capacity Utilization:	73.5%
ICU Level of Service:	D
Analysis Period (min):	15

Splits and Phases: 2: Shiloh Road & Hembree Ln

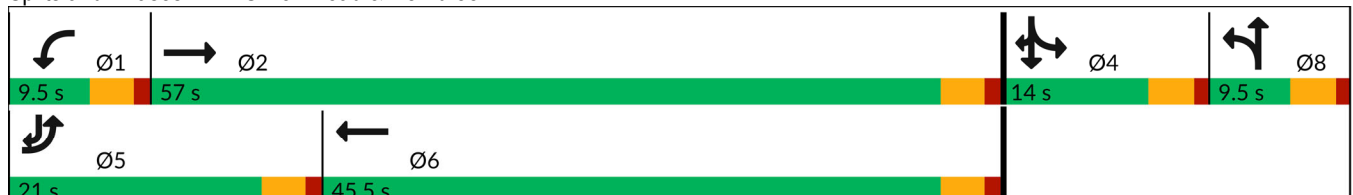

Lanes, Volumes, Timings  
 3: US 101 NB Off-Ramp & Shiloh Road

2028 Opening Year Alter. C Project Conditions

Timing Plan: Saturday Midday Peak

	→	↘	↙	←	↖	↗
Lane Group	EBT	EBR	WBL	WBT	NBL	NBR
Lane Configurations	↑↑			↑	↘	↗
Traffic Volume (vph)	493	0	0	869	401	735
Future Volume (vph)	493	0	0	869	401	735
Ideal Flow (vphpl)	1900	1900	1900	1900	1900	1900
Storage Length (ft)		0	0		0	265
Storage Lanes		0	0		1	2
Taper Length (ft)			25		25	
Lane Util. Factor	0.95	1.00	1.00	1.00	1.00	0.88
Ped Bike Factor						
Frt						0.850
Flt Protected					0.950	
Satd. Flow (prot)	3539	0	0	1863	1770	2787
Flt Permitted					0.950	
Satd. Flow (perm)	3539	0	0	1863	1770	2787
Right Turn on Red		Yes				Yes
Satd. Flow (RTOR)						400
Link Speed (mph)	40			40	30	
Link Distance (ft)	186			371	769	
Travel Time (s)	3.2			6.3	17.5	
Confl. Bikes (#/hr)		1				
Peak Hour Factor	0.91	0.91	0.89	0.89	0.95	0.95
Adj. Flow (vph)	542	0	0	976	422	774
Shared Lane Traffic (%)						
Lane Group Flow (vph)	542	0	0	976	422	774
Enter Blocked Intersection	No	No	No	No	No	No
Lane Alignment	Left	Right	Left	Left	Left	Right
Median Width(ft)	0			0	12	
Link Offset(ft)	0			0	0	
Crosswalk Width(ft)	16			16	16	
Two way Left Turn Lane						
Headway Factor	1.00	1.00	1.00	1.00	1.00	1.00
Turning Speed (mph)		9	15		15	9
Number of Detectors	2			2	1	1
Detector Template	Thru			Thru	Left	Right
Leading Detector (ft)	100			100	20	20
Trailing Detector (ft)	0			0	0	0
Detector 1 Position(ft)	0			0	0	0
Detector 1 Size(ft)	6			6	20	20
Detector 1 Type	Cl+Ex			Cl+Ex	Cl+Ex	Cl+Ex
Detector 1 Channel						
Detector 1 Extend (s)	0.0			0.0	0.0	0.0
Detector 1 Queue (s)	0.0			0.0	0.0	0.0
Detector 1 Delay (s)	0.0			0.0	0.0	0.0
Detector 2 Position(ft)	94			94		
Detector 2 Size(ft)	6			6		
Detector 2 Type	Cl+Ex			Cl+Ex		
Detector 2 Channel						
Detector 2 Extend (s)	0.0			0.0		
Turn Type	NA			NA	Prot	Perm

Lanes, Volumes, Timings  
 3: US 101 NB Off-Ramp & Shiloh Road

2028 Opening Year Alter. C Project Conditions

Timing Plan: Saturday Midday Peak



Lane Group	EBT	EBR	WBL	WBT	NBL	NBR
Protected Phases	2			6	8	
Permitted Phases						8
Detector Phase	2			6	8	8
Switch Phase						
Minimum Initial (s)	5.0			5.0	5.0	5.0
Minimum Split (s)	9.5			9.5	9.5	9.5
Total Split (s)	37.0			37.0	35.0	35.0
Total Split (%)	51.4%			51.4%	48.6%	48.6%
Maximum Green (s)	32.5			32.5	30.5	30.5
Yellow Time (s)	3.5			3.5	3.5	3.5
All-Red Time (s)	1.0			1.0	1.0	1.0
Lost Time Adjust (s)	0.0			0.0	0.0	0.0
Total Lost Time (s)	4.5			4.5	4.5	4.5
Lead/Lag						
Lead-Lag Optimize?						
Vehicle Extension (s)	3.0			3.0	3.0	3.0
Recall Mode	None			None	None	None
Act Effct Green (s)	32.8			32.8	21.4	21.4
Actuated g/C Ratio	0.52			0.52	0.34	0.34
v/c Ratio	0.30			1.01	0.71	0.64
Control Delay (s/veh)	10.3			51.8	24.9	10.3
Queue Delay	0.0			0.0	0.0	0.0
Total Delay (s/veh)	10.3			51.8	24.9	10.3
LOS	B			D	C	B
Approach Delay (s/veh)	10.3			51.8	15.5	
Approach LOS	B			D	B	

Intersection Summary

Area Type: Other  
 Cycle Length: 72  
 Actuated Cycle Length: 63.2  
 Natural Cycle: 70  
 Control Type: Actuated-Uncoordinated  
 Maximum v/c Ratio: 1.01  
 Intersection Signal Delay (s/veh): 27.5  
 Intersection LOS: C  
 Intersection Capacity Utilization 116.3%  
 ICU Level of Service H  
 Analysis Period (min) 15

Splits and Phases: 3: US 101 NB Off-Ramp & Shiloh Road

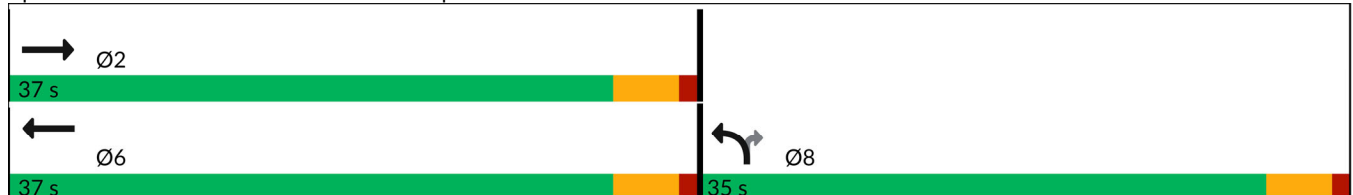



Lanes, Volumes, Timings  
4: Shiloh Road & US 101 SB Off-Ramp

2028 Opening Year Alter. C Project Conditions

Timing Plan: Saturday Midday Peak

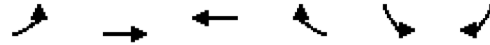

Lane Group	EBL	EBT	WBT	WBR	SBL	SBR
Lane Configurations		↑	↑		↘	↗
Traffic Volume (vph)	0	326	610	0	255	174
Future Volume (vph)	0	326	610	0	255	174
Ideal Flow (vphp)	1900	1900	1900	1900	1900	1900
Storage Length (ft)	0			0	0	275
Storage Lanes	0			0	1	1
Taper Length (ft)	25				25	
Lane Util. Factor	1.00	1.00	1.00	1.00	1.00	1.00
Ped Bike Factor						
Frt						0.850
Flt Protected					0.950	
Satd. Flow (prot)	0	1863	1863	0	1770	1583
Flt Permitted					0.950	
Satd. Flow (perm)	0	1863	1863	0	1770	1583
Right Turn on Red				Yes		Yes
Satd. Flow (RTOR)						256
Link Speed (mph)		40	40		30	
Link Distance (ft)		225	306		486	
Travel Time (s)		3.8	5.2		11.0	
Confl. Bikes (#/hr)				2		
Peak Hour Factor	0.96	0.96	0.96	0.96	0.68	0.68
Adj. Flow (vph)	0	340	635	0	375	256
Shared Lane Traffic (%)						
Lane Group Flow (vph)	0	340	635	0	375	256
Enter Blocked Intersection	No	No	No	No	No	No
Lane Alignment	Left	Left	Left	Right	Left	Right
Median Width(ft)		4	0		12	
Link Offset(ft)		0	0		0	
Crosswalk Width(ft)		16	16		16	
Two way Left Turn Lane						
Headway Factor	1.00	1.00	1.00	1.00	1.00	1.00
Turning Speed (mph)	15			9	15	9
Number of Detectors		2	2		1	1
Detector Template		Thru	Thru		Left	Right
Leading Detector (ft)		100	100		20	20
Trailing Detector (ft)		0	0		0	0
Detector 1 Position(ft)		0	0		0	0
Detector 1 Size(ft)		6	6		20	20
Detector 1 Type		Cl+Ex	Cl+Ex		Cl+Ex	Cl+Ex
Detector 1 Channel						
Detector 1 Extend (s)		0.0	0.0		0.0	0.0
Detector 1 Queue (s)		0.0	0.0		0.0	0.0
Detector 1 Delay (s)		0.0	0.0		0.0	0.0
Detector 2 Position(ft)		94	94			
Detector 2 Size(ft)		6	6			
Detector 2 Type		Cl+Ex	Cl+Ex			
Detector 2 Channel						
Detector 2 Extend (s)		0.0	0.0			
Turn Type		NA	NA		Perm	Perm

Lanes, Volumes, Timings  
4: Shiloh Road & US 101 SB Off-Ramp

2028 Opening Year Alter. C Project Conditions

Timing Plan: Saturday Midday Peak



Lane Group	EBL	EBT	WBT	WBR	SBL	SBR
Protected Phases		2	6			
Permitted Phases					4	4
Detector Phase		2	6		4	4
Switch Phase						
Minimum Initial (s)		5.0	5.0		5.0	5.0
Minimum Split (s)		9.5	38.5		9.5	9.5
Total Split (s)		69.0	69.0		21.0	21.0
Total Split (%)		76.7%	76.7%		23.3%	23.3%
Maximum Green (s)		64.5	64.5		16.5	16.5
Yellow Time (s)		3.5	3.5		3.5	3.5
All-Red Time (s)		1.0	1.0		1.0	1.0
Lost Time Adjust (s)		0.0	0.0		0.0	0.0
Total Lost Time (s)		4.5	4.5		4.5	4.5
Lead/Lag						
Lead-Lag Optimize?						
Vehicle Extension (s)		3.0	3.0		3.0	3.0
Recall Mode		None	None		None	None
Walk Time (s)			7.0			
Flash Don't Walk (s)			27.0			
Pedestrian Calls (#/hr)			0			
Act Effct Green (s)		21.3	21.3		16.7	16.7
Actuated g/C Ratio		0.45	0.45		0.35	0.35
v/c Ratio		0.40	0.76		0.60	0.35
Control Delay (s/veh)		9.8	16.9		20.0	4.1
Queue Delay		0.0	0.0		0.0	0.0
Total Delay (s/veh)		9.8	16.9		20.0	4.1
LOS		A	B		B	A
Approach Delay (s/veh)		9.8	16.9		13.5	
Approach LOS		A	B		B	

Intersection Summary

Area Type:	Other
Cycle Length:	90
Actuated Cycle Length:	47.2
Natural Cycle:	60
Control Type:	Actuated-Uncoordinated
Maximum v/c Ratio:	0.76
Intersection Signal Delay (s/veh):	14.1
Intersection LOS:	B
Intersection Capacity Utilization:	110.9%
ICU Level of Service:	H
Analysis Period (min):	15

Splits and Phases: 4: Shiloh Road & US 101 SB Off-Ramp

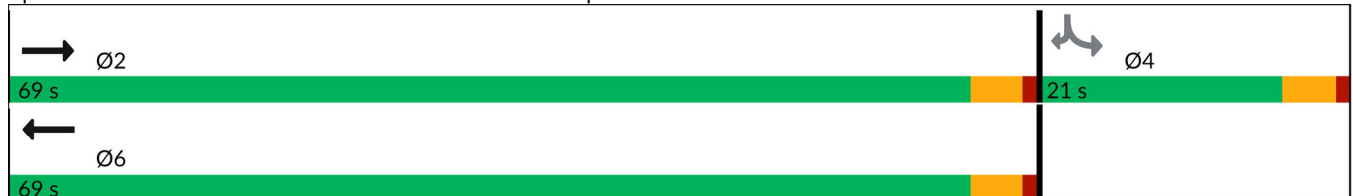

Lanes, Volumes, Timings  
5: Caletti Ave & Shiloh Road

2028 Opening Year Alter. C Project Conditions  
Timing Plan: Saturday Midday Peak



















	→	↘	↙	←	↖	↗
Lane Group	EBT	EBR	WBL	WBT	NBL	NBR
Lane Configurations	↑↑		↘	↑	↘	↗
Traffic Volume (vph)	620	23	92	686	18	89
Future Volume (vph)	620	23	92	686	18	89
Ideal Flow (vphp)	1900	1900	1900	1900	1900	1900
Storage Length (ft)		0	68		0	0
Storage Lanes		0	1		1	1
Taper Length (ft)			50		25	
Lane Util. Factor	0.95	0.95	1.00	1.00	1.00	1.00
Ped Bike Factor						
Frt	0.995					0.850
Flt Protected			0.950		0.950	
Satd. Flow (prot)	3522	0	1770	1863	1770	1583
Flt Permitted			0.950		0.950	
Satd. Flow (perm)	3522	0	1770	1863	1770	1583
Link Speed (mph)	40			40	30	
Link Distance (ft)	1081			184	459	
Travel Time (s)	18.4			3.1	10.4	
Confl. Peds. (#/hr)					1	
Confl. Bikes (#/hr)		1				
Peak Hour Factor	0.92	0.92	0.87	0.87	0.78	0.78
Adj. Flow (vph)	674	25	106	789	23	114
Shared Lane Traffic (%)						
Lane Group Flow (vph)	699	0	106	789	23	114
Enter Blocked Intersection	No	No	No	No	No	No
Lane Alignment	Left	Right	Left	Left	Left	Right
Median Width(ft)	12			12	12	
Link Offset(ft)	0			0	0	
Crosswalk Width(ft)	16			16	16	
Two way Left Turn Lane						
Headway Factor	1.00	1.00	1.00	1.00	1.00	1.00
Turning Speed (mph)		9	15		15	9
Sign Control	Free			Free	Stop	

Intersection Summary

Area Type:	Other
Control Type:	Unsignalized
Intersection Capacity Utilization	46.1%
Analysis Period (min)	15
	ICU Level of Service A

Lanes, Volumes, Timings  
6: Conde Lane & Shiloh Road

2028 Opening Year Alter. C Project Conditions  
Timing Plan: Saturday Midday Peak

												
Lane Group	EBL	EBT	EBR	WBL	WBT	WBR	NBL	NBT	NBR	SBL	SBT	SBR
Lane Configurations												
Traffic Volume (vph)	33	410	1	10	458	232	1	0	7	224	0	32
Future Volume (vph)	33	410	1	10	458	232	1	0	7	224	0	32
Ideal Flow (vphpl)	1900	1900	1900	1900	1900	1900	1900	1900	1900	1900	1900	1900
Storage Length (ft)	90		0	127		0	0		0	0		40
Storage Lanes	1		0	1		0	0		0	0		1
Taper Length (ft)	70			40			25			25		
Lane Util. Factor	1.00	0.95	0.95	1.00	0.95	0.95	1.00	1.00	1.00	1.00	1.00	1.00
Ped Bike Factor					0.99							
Frt					0.950			0.884				0.850
Flt Protected	0.950			0.950				0.993			0.950	
Satd. Flow (prot)	1770	3539	0	1770	3337	0	0	1635	0	0	1770	1583
Flt Permitted	0.950			0.950				0.993			0.950	
Satd. Flow (perm)	1770	3539	0	1770	3337	0	0	1635	0	0	1770	1583
Right Turn on Red			Yes			Yes			Yes			No
Satd. Flow (RTOR)					90			102				
Link Speed (mph)		40			40			30				35
Link Distance (ft)		815			1081			418				522
Travel Time (s)		13.9			18.4			9.5				10.2
Confl. Bikes (#/hr)						2						
Peak Hour Factor	0.96	0.96	0.96	0.91	0.91	0.91	0.58	0.58	0.58	0.78	0.78	0.78
Adj. Flow (vph)	34	427	1	11	503	255	2	0	12	287	0	41
Shared Lane Traffic (%)												
Lane Group Flow (vph)	34	428	0	11	758	0	0	14	0	0	287	41
Enter Blocked Intersection	No	No	No	No	No	No	No	No	No	No	No	No
Lane Alignment	Left	Left	Right	Left	Left	Right	Left	Left	Right	Left	Left	Right
Median Width(ft)		12			12			0				0
Link Offset(ft)		0			0			0				0
Crosswalk Width(ft)		16			16			16				16
Two way Left Turn Lane												
Headway Factor	1.00	1.00	1.00	1.00	1.00	1.00	1.00	1.00	1.00	1.00	1.00	1.00
Turning Speed (mph)	15		9	15		9	15		9	15		9
Number of Detectors	1	2		1	2		1	2		1	1	1
Detector Template	Left	Thru		Left	Thru		Left	Thru		Left	Thru	Right
Leading Detector (ft)	20	100		20	100		20	100		20	30	20
Trailing Detector (ft)	0	0		0	0		0	0		0	0	0
Detector 1 Position(ft)	0	0		0	0		0	0		0	0	0
Detector 1 Size(ft)	20	6		20	6		20	6		20	30	20
Detector 1 Type	Cl+Ex	Cl+Ex		Cl+Ex	Cl+Ex		Cl+Ex	Cl+Ex		Cl+Ex	Cl+Ex	Cl+Ex
Detector 1 Channel												
Detector 1 Extend (s)	0.0	0.0		0.0	0.0		0.0	0.0		0.0	0.0	0.0
Detector 1 Queue (s)	0.0	0.0		0.0	0.0		0.0	0.0		0.0	0.0	0.0
Detector 1 Delay (s)	0.0	0.0		0.0	0.0		0.0	0.0		0.0	0.0	0.0
Detector 2 Position(ft)		94			94			94				
Detector 2 Size(ft)		6			6			6				
Detector 2 Type		Cl+Ex			Cl+Ex			Cl+Ex				
Detector 2 Channel												
Detector 2 Extend (s)		0.0			0.0			0.0				
Turn Type	Prot	NA		Prot	NA		Split	NA		Split	NA	custom

Lanes, Volumes, Timings  
6: Conde Lane & Shiloh Road

2028 Opening Year Alter. C Project Conditions

Timing Plan: Saturday Midday Peak

Lane Group	EBL	EBT	EBR	WBL	WBT	WBR	NBL	NBT	NBR	SBL	SBT	SBR
Protected Phases	5	2		1	6		7	7		4	4	
Permitted Phases												6
Detector Phase	5	2		1	6		7	7		4	4	6
Switch Phase												
Minimum Initial (s)	8.0	8.0		8.0	8.0		10.0	10.0		11.0	11.0	8.0
Minimum Split (s)	12.5	46.5		12.5	12.5		37.5	37.5		15.5	15.5	12.5
Total Split (s)	13.0	46.5		12.5	45.0		37.5	37.5		15.5	15.5	45.0
Total Split (%)	11.6%	41.5%		11.2%	40.2%		33.5%	33.5%		13.8%	13.8%	40.2%
Maximum Green (s)	8.5	42.0		8.0	40.5		33.0	33.0		11.0	11.0	40.5
Yellow Time (s)	3.5	3.5		3.5	3.5		3.5	3.5		3.5	3.5	3.5
All-Red Time (s)	1.0	1.0		1.0	1.0		1.0	1.0		1.0	1.0	1.0
Lost Time Adjust (s)	0.0	0.0		0.0	0.0		0.0	0.0		0.0	0.0	0.0
Total Lost Time (s)	4.5	4.5		4.5	4.5		4.5	4.5		4.5	4.5	4.5
Lead/Lag	Lead	Lag		Lead	Lag							Lag
Lead-Lag Optimize?	Yes	Yes		Yes	Yes							Yes
Vehicle Extension (s)	3.0	3.0		3.0	3.0		3.0	3.0		3.0	3.0	3.0
Recall Mode	None	None		None	None		None	None		None	None	None
Walk Time (s)		7.0					7.0	7.0				
Flash Don't Walk (s)		35.0					26.0	26.0				
Pedestrian Calls (#/hr)		0					0	0				
Act Effct Green (s)	9.1	19.3		9.0	17.0		11.3			12.4	17.0	
Actuated g/C Ratio	0.20	0.43		0.20	0.38		0.25			0.28	0.38	
v/c Ratio	0.10	0.28		0.03	0.58		0.03			0.59	0.07	
Control Delay (s/veh)	23.5	9.9		24.0	12.9		0.1			28.1	12.2	
Queue Delay	0.0	0.0		0.0	0.0		0.0			0.0	0.0	
Total Delay (s/veh)	23.5	9.9		24.0	12.9		0.1			28.1	12.2	
LOS	C	A		C	B		A			C	B	
Approach Delay (s/veh)		10.9			13.1		0.1			26.1		
Approach LOS		B			B		A			C		

Intersection Summary

Area Type:	Other
Cycle Length:	112
Actuated Cycle Length:	45
Natural Cycle:	115
Control Type:	Actuated-Uncoordinated
Maximum v/c Ratio:	0.59
Intersection Signal Delay (s/veh):	15.0
Intersection LOS:	B
Intersection Capacity Utilization:	54.0%
ICU Level of Service:	A
Analysis Period (min):	15



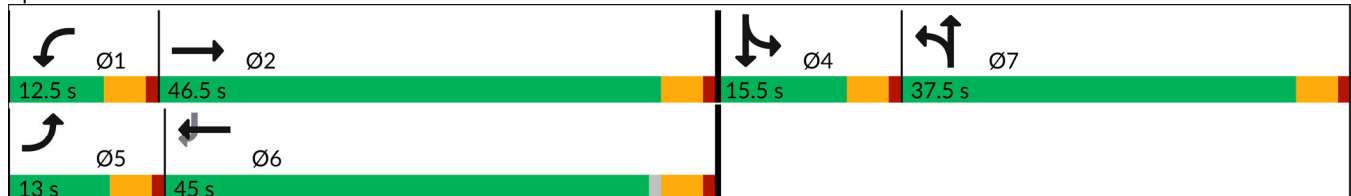













Splits and Phases: 6: Conde Lane & Shiloh Road



Lanes, Volumes, Timings  
7: Driveway 1/Gridley Drive & Shiloh Road

2028 Opening Year Alter. C Project Conditions



















Timing Plan: Saturday Midday Peak

												
Lane Group	EBL	EBT	EBR	WBL	WBT	WBR	NBL	NBT	NBR	SBL	SBT	SBR
Lane Configurations												
Traffic Volume (vph)	23	121	112	8	105	0	133	0	9	0	0	20
Future Volume (vph)	23	121	112	8	105	0	133	0	9	0	0	20
Ideal Flow (vphpl)	1900	1900	1900	1900	1900	1900	1900	1900	1900	1900	1900	1900
Lane Util. Factor	1.00	1.00	1.00	1.00	1.00	1.00	1.00	1.00	1.00	1.00	1.00	1.00
Ped Bike Factor												
Frt		0.941						0.850			0.865	
Flt Protected		0.995			0.996		0.950					
Satd. Flow (prot)	0	1744	0	0	1855	0	1770	1583	0	0	1611	0
Flt Permitted		0.995			0.996		0.950					
Satd. Flow (perm)	0	1744	0	0	1855	0	1770	1583	0	0	1611	0
Link Speed (mph)		40			40			30			30	
Link Distance (ft)		608			2146			248			715	
Travel Time (s)		10.4			36.6			5.6			16.3	
Confl. Peds. (#/hr)	1											
Confl. Bikes (#/hr)			1			3						
Peak Hour Factor	0.93	0.93	0.93	0.88	0.88	0.88	1.00	1.00	1.00	0.56	0.56	0.56
Adj. Flow (vph)	25	130	120	9	119	0	133	0	9	0	0	36
Shared Lane Traffic (%)												
Lane Group Flow (vph)	0	275	0	0	128	0	133	9	0	0	36	0
Enter Blocked Intersection	No	No	No	No	No	No	No	No	No	No	No	No
Lane Alignment	Left	Left	Right	Left	Left	Right	Left	Left	Right	Left	Left	Right
Median Width(ft)		0			0			12			12	
Link Offset(ft)		0			0			0			0	
Crosswalk Width(ft)		16			16			16			16	
Two way Left Turn Lane												
Headway Factor	1.00	1.00	1.00	1.00	1.00	1.00	1.00	1.00	1.00	1.00	1.00	1.00
Turning Speed (mph)	15		9	15		9	15		9	15		9
Sign Control		Free			Free			Stop			Stop	
<b>Intersection Summary</b>												
Area Type:	Other											
Control Type:	Unsignalized											
Intersection Capacity Utilization	40.8%						ICU Level of Service A					
Analysis Period (min)	15											

Lanes, Volumes, Timings  
8: Old Redwood Hwy & Driveway 2

2028 Opening Year Alter. C Project Conditions

Timing Plan: Saturday Midday Peak

												
Lane Group	EBL	EBT	EBR	WBL	WBT	WBR	NBL	NBT	NBR	SBL	SBT	SBR
Lane Configurations												
Traffic Volume (vph)	1	0	2	19	0	31	1	459	17	27	389	5
Future Volume (vph)	1	0	2	19	0	31	1	459	17	27	389	5
Ideal Flow (vphp)	1900	1900	1900	1900	1900	1900	1900	1900	1900	1900	1900	1900
Storage Length (ft)	0		0	0		0	0		0	50		0
Storage Lanes	0		0	1		0	0		0	1		0
Taper Length (ft)	25			25			25			25		
Lane Util. Factor	1.00	1.00	1.00	1.00	1.00	1.00	1.00	1.00	1.00	1.00	1.00	1.00
Ped Bike Factor												
Frt		0.916			0.850			0.995				0.998
Flt Protected		0.982		0.950						0.950		
Satd. Flow (prot)	0	1676	0	1770	1583	0	0	1853	0	1770	1859	0
Flt Permitted		0.982		0.950						0.950		
Satd. Flow (perm)	0	1676	0	1770	1583	0	0	1853	0	1770	1859	0
Link Speed (mph)		30			30			45			45	
Link Distance (ft)		98			385			520			748	
Travel Time (s)		2.2			8.8			7.9			11.3	
Confl. Peds. (#/hr)							1		4	4		1
Confl. Bikes (#/hr)									3			9
Peak Hour Factor	0.38	0.38	0.38	1.00	1.00	1.00	0.94	0.94	0.94	0.93	0.93	0.93
Adj. Flow (vph)	3	0	5	19	0	31	1	488	18	29	418	5
Shared Lane Traffic (%)												
Lane Group Flow (vph)	0	8	0	19	31	0	0	507	0	29	423	0
Enter Blocked Intersection	No	No	No	No	No	No	No	No	No	No	No	No
Lane Alignment	Left	Left	Right	Left	Left	Right	Left	Left	Right	Left	Left	Right
Median Width(ft)		12			12			12			12	
Link Offset(ft)		0			0			0			0	
Crosswalk Width(ft)		16			16			16			16	
Two way Left Turn Lane												
Headway Factor	1.00	1.00	1.00	1.00	1.00	1.00	1.00	1.00	1.00	1.00	1.00	1.00
Turning Speed (mph)	15		9	15		9	15		9	15		9
Sign Control		Stop			Stop			Free			Free	

Intersection Summary

Area Type:	Other
Control Type:	Unsignalized
Intersection Capacity Utilization	36.0%
Analysis Period (min)	15
	ICU Level of Service A

Lanes, Volumes, Timings  
9: Shiloh Road

2028 Opening Year Alter. C Project Conditions

Timing Plan: Saturday Midday Peak

	→	↘	↙	←	↖	↗
Lane Group	EBT	EBR	WBL	WBT	NBL	NBR
Lane Configurations	↗			↖	↘	↗
Traffic Volume (vph)	114	0	0	106	0	0
Future Volume (vph)	114	0	0	106	0	0
Ideal Flow (vphpl)	1900	1900	1900	1900	1900	1900
Lane Util. Factor	1.00	1.00	1.00	1.00	1.00	1.00
Ped Bike Factor						
Frt						
Flt Protected						
Satd. Flow (prot)	1863	0	0	1863	1863	1863
Flt Permitted						
Satd. Flow (perm)	1863	0	0	1863	1863	1863
Link Speed (mph)	40			40	30	
Link Distance (ft)	2146			134	402	
Travel Time (s)	36.6			2.3	9.1	
Confl. Peds. (#/hr)		1				
Peak Hour Factor	0.88	0.88	0.80	0.80	1.00	1.00
Adj. Flow (vph)	130	0	0	133	0	0
Shared Lane Traffic (%)						
Lane Group Flow (vph)	130	0	0	133	0	0
Enter Blocked Intersection	No	No	No	No	No	No
Lane Alignment	Left	Right	Left	Left	Left	Right
Median Width(ft)	0			0	12	
Link Offset(ft)	0			0	0	
Crosswalk Width(ft)	16			16	16	
Two way Left Turn Lane						
Headway Factor	1.00	1.00	1.00	1.00	1.00	1.00
Turning Speed (mph)		9	15		15	9
Sign Control	Free			Free	Stop	
<b>Intersection Summary</b>						
Area Type:	Other					
Control Type:	Unsignalized					
Intersection Capacity Utilization	9.6%			ICU Level of Service A		
Analysis Period (min)	15					



Lanes, Volumes, Timings

2028 Opening Year Alter. C Project Conditions

10: US 101 NB Off Ramp/Lakewood Drive & Old Redwood Highway Timing Plan: Saturday Midday Peak



Lane Group	EBL	EBT	EBR	WBL	WBT	WBR	NBL	NBT	NBR	SBL	SBT	SBR
Lane Configurations												
Traffic Volume (vph)	287	330	0	0	521	276	320	303	142	244	0	700
Future Volume (vph)	287	330	0	0	521	276	320	303	142	244	0	700
Ideal Flow (vphpl)	1900	1900	1900	1900	1900	1900	1900	1900	1900	1900	1900	1900
Storage Length (ft)	155		0	0		0	270		150	120		0
Storage Lanes	1		0	0		0	1		1	1		1
Taper Length (ft)	50			25			165			75		
Lane Util. Factor	0.97	1.00	1.00	1.00	0.95	0.95	0.91	0.91	0.95	0.97	1.00	1.00
Ped Bike Factor	1.00				0.99			1.00		1.00		
Fr <sub>t</sub>					0.948			0.958				0.850
Fl <sub>t</sub> Protected	0.950						0.950	0.994		0.950		
Satd. Flow (prot)	3433	1863	0	0	3336	0	1610	3217	0	3433	0	1583
Fl <sub>t</sub> Permitted	0.950						0.950	0.994		0.950		
Satd. Flow (perm)	3429	1863	0	0	3336	0	1610	3217	0	3430	0	1583
Right Turn on Red			Yes			Yes			Yes			Yes
Satd. Flow (RTOR)					112			61				289
Link Speed (mph)		35			35			30				30
Link Distance (ft)		226			617			716				478
Travel Time (s)		4.4			12.0			16.3				10.9
Confl. Peds. (#/hr)	2		1	1		2			1	1		
Confl. Bikes (#/hr)			10			3						
Peak Hour Factor	0.95	0.95	0.95	0.89	0.89	0.89	0.98	0.98	0.98	0.88	0.88	0.88
Adj. Flow (vph)	302	347	0	0	585	310	327	309	145	277	0	795
Shared Lane Traffic (%)							20%					
Lane Group Flow (vph)	302	347	0	0	895	0	262	519	0	277	0	795
Enter Blocked Intersection	No	No	No	No	No	No	No	No	No	No	No	No
Lane Alignment	Left	Left	Right	Left	Left	Right	Left	Left	Right	Left	Left	Right
Median Width(ft)		24			24			24				24
Link Offset(ft)		0			0			0				0
Crosswalk Width(ft)		16			16			16				16
Two way Left Turn Lane												
Headway Factor	1.00	1.00	1.00	1.00	1.00	1.00	1.00	1.00	1.00	1.00	1.00	1.00
Turning Speed (mph)	15		9	15		9	15		9	15		9
Number of Detectors	1	2			2		1	2		1		1
Detector Template	Left	Thru			Thru		Left	Thru		Left		Right
Leading Detector (ft)	20	100			100		20	100		20		20
Trailing Detector (ft)	0	0			0		0	0		0		0
Detector 1 Position(ft)	0	0			0		0	0		0		0
Detector 1 Size(ft)	20	6			6		20	6		20		20
Detector 1 Type	Cl+Ex	Cl+Ex			Cl+Ex		Cl+Ex	Cl+Ex		Cl+Ex		Cl+Ex
Detector 1 Channel												
Detector 1 Extend (s)	0.0	0.0			0.0		0.0	0.0		0.0		0.0
Detector 1 Queue (s)	0.0	0.0			0.0		0.0	0.0		0.0		0.0
Detector 1 Delay (s)	0.0	0.0			0.0		0.0	0.0		0.0		0.0
Detector 2 Position(ft)		94			94			94				
Detector 2 Size(ft)		6			6			6				
Detector 2 Type		Cl+Ex			Cl+Ex			Cl+Ex				
Detector 2 Channel												
Detector 2 Extend (s)		0.0			0.0			0.0				

Lanes, Volumes, Timings

2028 Opening Year Alter. C Project Conditions

10: US 101 NB Off Ramp/Lakewood Drive & Old Redwood Highway Timing Plan: Saturday Midday Peak



Lane Group	EBL	EBT	EBR	WBL	WBT	WBR	NBL	NBT	NBR	SBL	SBT	SBR
Turn Type	Prot	NA			NA		Split	NA		Prot		pm+ov
Protected Phases	5	2			6		8	8		7		5
Permitted Phases												5 8
Detector Phase	5	2			6		8	8		7		5
Switch Phase												
Minimum Initial (s)	7.0	10.0			10.0		10.0	10.0		7.0		7.0
Minimum Split (s)	11.5	32.1			32.1		33.7	33.7		11.5		11.5
Total Split (s)	12.0	45.3			33.3		33.7	33.7		11.5		12.0
Total Split (%)	13.3%	50.1%			36.8%		37.2%	37.2%		12.7%		13.3%
Maximum Green (s)	7.5	40.8			28.8		29.2	29.2		7.0		7.5
Yellow Time (s)	3.5	3.5			3.5		3.5	3.5		3.5		3.5
All-Red Time (s)	1.0	1.0			1.0		1.0	1.0		1.0		1.0
Lost Time Adjust (s)	0.0	0.0			0.0		0.0	0.0		0.0		0.0
Total Lost Time (s)	4.5	4.5			4.5		4.5	4.5		4.5		4.5
Lead/Lag	Lead				Lag		Lag	Lag		Lead		Lead
Lead-Lag Optimize?	Yes				Yes		Yes	Yes		Yes		Yes
Vehicle Extension (s)	3.0	3.0			3.0		3.0	3.0		3.0		3.0
Recall Mode	None	Max			Max		None	None		None		None
Walk Time (s)		7.0			7.0		7.0	7.0				
Flash Don't Walk (s)		20.0			17.0		22.0	22.0				
Pedestrian Calls (#/hr)		0			0		0	0				
Act Effct Green (s)	7.5	41.0			29.0		20.3	20.3		7.0		32.4
Actuated g/C Ratio	0.09	0.50			0.35		0.25	0.25		0.09		0.40
v/c Ratio	0.96	0.37			0.72		0.66	0.61		0.94		0.99
Control Delay (s/veh)	81.7	15.3			24.8		35.6	26.8		80.3		47.2
Queue Delay	0.0	0.0			0.0		0.0	0.0		0.0		0.0
Total Delay (s/veh)	81.7	15.3			24.8		35.6	26.8		80.3		47.2
LOS	F	B			C		D	C		F		D
Approach Delay (s/veh)		46.2			24.8			29.8				55.7
Approach LOS		D			C			C				E

Intersection Summary

Area Type: Other  
 Cycle Length: 90.5  
 Actuated Cycle Length: 82  
 Natural Cycle: 90  
 Control Type: Actuated-Uncoordinated  
 Maximum v/c Ratio: 0.99  
 Intersection Signal Delay (s/veh): 39.8  
 Intersection LOS: D  
 Intersection Capacity Utilization 93.0%  
 ICU Level of Service F  
 Analysis Period (min) 15

Splits and Phases: 10: US 101 NB Off Ramp/Lakewood Drive & Old Redwood Highway

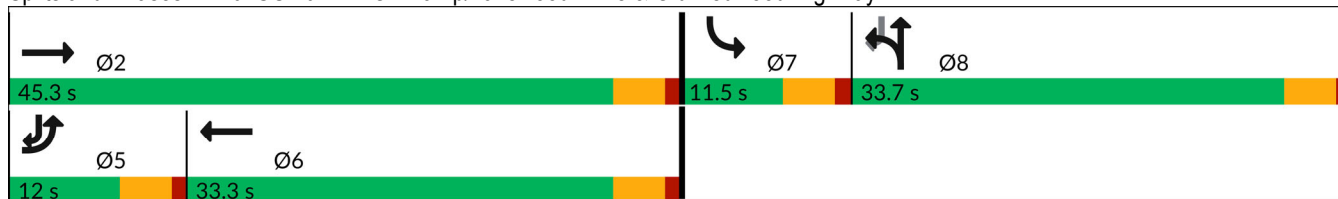

Lanes, Volumes, Timings  
 11: Old Redwood Highway & US 101 NB On Ramp

2028 Opening Year Alter. C Project Conditions

Timing Plan: Saturday Midday Peak

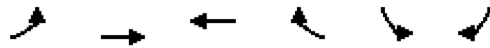

Lane Group	EBL	EBT	WBT	WBR	SBL	SBR
Lane Configurations	↶	↕↕	↶↶			
Traffic Volume (vph)	87	622	1310	215	0	0
Future Volume (vph)	87	622	1310	215	0	0
Ideal Flow (vphp)	1900	1900	1900	1900	1900	1900
Storage Length (ft)	245			0	0	0
Storage Lanes	1			0	0	0
Taper Length (ft)	50				25	
Lane Util. Factor	1.00	0.95	0.95	0.95	1.00	1.00
Ped Bike Factor						
Frt			0.979			
Flt Protected	0.950					
Satd. Flow (prot)	1770	3539	3465	0	0	0
Flt Permitted	0.950					
Satd. Flow (perm)	1770	3539	3465	0	0	0
Link Speed (mph)		35	35		30	
Link Distance (ft)		531	226		299	
Travel Time (s)		10.3	4.4		6.8	
Confl. Peds. (#/hr)	8			8		
Confl. Bikes (#/hr)				4		
Peak Hour Factor	0.96	0.96	0.92	0.92	0.25	0.25
Adj. Flow (vph)	91	648	1424	234	0	0
Shared Lane Traffic (%)						
Lane Group Flow (vph)	91	648	1658	0	0	0
Enter Blocked Intersection	No	No	No	No	No	No
Lane Alignment	Left	Left	Left	Right	Left	Right
Median Width(ft)		12	12		0	
Link Offset(ft)		0	0		0	
Crosswalk Width(ft)		16	16		16	
Two way Left Turn Lane						
Headway Factor	1.00	1.00	1.00	1.00	1.00	1.00
Turning Speed (mph)	15			9	15	9
Sign Control		Free	Free		Free	

Intersection Summary

Area Type:	Other
Control Type:	Unsignalized
Intersection Capacity Utilization	72.7%
Analysis Period (min)	15
	ICU Level of Service C

Lanes, Volumes, Timings

2028 Opening Year Alter. C Project Conditions

12: US 101 SB On Ramp/US 101 SB Off Ramp & Old Redwood Highway Timing Plan: Saturday Midday Peak



Lane Group	EBL	EBT	EBR	WBL	WBT	WBR	NBL	NBT	NBR	SBL	SBT	SBR
Lane Configurations		↑↑	↗	↘	↑↑					↘	↕	
Traffic Volume (vph)	0	550	419	487	818	0	0	0	0	168	1	87
Future Volume (vph)	0	550	419	487	818	0	0	0	0	168	1	87
Ideal Flow (vphpl)	1900	1900	1900	1900	1900	1900	1900	1900	1900	1900	1900	1900
Storage Length (ft)	0		0	250		0	0		0	420		0
Storage Lanes	0		1	0		0	0		0	1		0
Taper Length (ft)	25			165			25			75		
Lane Util. Factor	1.00	0.95	1.00	1.00	0.95	1.00	1.00	1.00	1.00	0.95	0.95	1.00
Ped Bike Factor			0.98	1.00								
Frt			0.850								0.894	
Flt Protected				0.950						0.950	0.986	
Satd. Flow (prot)	0	3539	1583	1770	3539	0	0	0	0	1681	1560	0
Flt Permitted				0.950						0.950	0.986	
Satd. Flow (perm)	0	3539	1553	1768	3539	0	0	0	0	1681	1560	0
Right Turn on Red			Yes			Yes			Yes			Yes
Satd. Flow (RTOR)			432								121	
Link Speed (mph)		35			35			30			30	
Link Distance (ft)		423			531			621			831	
Travel Time (s)		8.2			10.3			14.1			18.9	
Confl. Peds. (#/hr)	11		2	2		11						
Confl. Bikes (#/hr)			10			2						
Peak Hour Factor	0.97	0.97	0.97	0.96	0.96	0.96	0.25	0.25	0.25	0.72	0.72	0.72
Adj. Flow (vph)	0	567	432	507	852	0	0	0	0	233	1	121
Shared Lane Traffic (%)										21%		
Lane Group Flow (vph)	0	567	432	507	852	0	0	0	0	184	171	0
Enter Blocked Intersection	No	No	No	No	No	No	No	No	No	No	No	No
Lane Alignment	Left	Left	Right	Left	Left	Right	Left	Left	Right	Left	Left	Right
Median Width(ft)		24			24			12			12	
Link Offset(ft)		0			0			0			0	
Crosswalk Width(ft)		16			16			16			16	
Two way Left Turn Lane												
Headway Factor	1.00	1.00	1.00	1.00	1.00	1.00	1.00	1.00	1.00	1.00	1.00	1.00
Turning Speed (mph)	15		9	15		9	15		9	15		9
Number of Detectors		2	1	1	2					1	2	
Detector Template		Thru	Right	Left	Thru					Left	Thru	
Leading Detector (ft)		100	20	20	100					20	100	
Trailing Detector (ft)		0	0	0	0					0	0	
Detector 1 Position(ft)		0	0	0	0					0	0	
Detector 1 Size(ft)		6	20	20	6					20	6	
Detector 1 Type		Cl+Ex	Cl+Ex	Cl+Ex	Cl+Ex					Cl+Ex	Cl+Ex	
Detector 1 Channel												
Detector 1 Extend (s)		0.0	0.0	0.0	0.0					0.0	0.0	
Detector 1 Queue (s)		0.0	0.0	0.0	0.0					0.0	0.0	
Detector 1 Delay (s)		0.0	0.0	0.0	0.0					0.0	0.0	
Detector 2 Position(ft)		94			94							94
Detector 2 Size(ft)		6			6							6
Detector 2 Type		Cl+Ex			Cl+Ex							Cl+Ex
Detector 2 Channel												
Detector 2 Extend (s)		0.0			0.0							0.0

Lanes, Volumes, Timings

2028 Opening Year Alter. C Project Conditions

12: US 101 SB On Ramp/US 101 SB Off Ramp & Old Redwood Highway Timing Plan: Saturday Midday Peak



Lane Group	EBL	EBT	EBR	WBL	WBT	WBR	NBL	NBT	NBR	SBL	SBT	SBR
Turn Type		NA	Perm	Prot	NA					Perm	NA	
Protected Phases		6		5	2						8	
Permitted Phases			6							8		
Detector Phase		6	6	5	2					8	8	
Switch Phase												
Minimum Initial (s)		10.0	10.0	7.0	10.0					10.0	10.0	
Minimum Split (s)		32.1	32.1	11.5	38.1					14.7	14.7	
Total Split (s)		32.3	32.3	23.0	55.3					14.7	14.7	
Total Split (%)		46.1%	46.1%	32.9%	79.0%					21.0%	21.0%	
Maximum Green (s)		27.8	27.8	18.5	50.8					10.2	10.2	
Yellow Time (s)		3.5	3.5	3.5	3.5					3.5	3.5	
All-Red Time (s)		1.0	1.0	1.0	1.0					1.0	1.0	
Lost Time Adjust (s)		0.0	0.0	0.0	0.0					0.0	0.0	
Total Lost Time (s)		4.5	4.5	4.5	4.5					4.5	4.5	
Lead/Lag		Lag	Lag	Lead								
Lead-Lag Optimize?		Yes	Yes	Yes								
Vehicle Extension (s)		3.0	3.0	3.0	3.0					3.0	3.0	
Recall Mode		Max	Max	None	Max					None	None	
Walk Time (s)		7.0	7.0		7.0							
Flash Don't Walk (s)		20.0	20.0		25.0							
Pedestrian Calls (#/hr)		0	0		0							
Act Effct Green (s)		27.8	27.8	18.5	50.8					10.2	10.2	
Actuated g/C Ratio		0.40	0.40	0.26	0.73					0.15	0.15	
v/c Ratio		0.40	0.49	1.09	0.33					0.76	0.52	
Control Delay (s/veh)		16.2	3.8	94.8	3.9					50.7	16.3	
Queue Delay		0.0	0.0	0.0	0.0					0.0	0.0	
Total Delay (s/veh)		16.2	3.8	94.8	3.9					50.7	16.3	
LOS		B	A	F	A					D	B	
Approach Delay (s/veh)		10.9			37.8						34.1	
Approach LOS		B			D						C	

Intersection Summary

Area Type: Other  
 Cycle Length: 70  
 Actuated Cycle Length: 70  
 Natural Cycle: 80  
 Control Type: Actuated-Uncoordinated  
 Maximum v/c Ratio: 1.09  
 Intersection Signal Delay (s/veh): 27.4  
 Intersection LOS: C  
 Intersection Capacity Utilization 72.7%  
 ICU Level of Service C  
 Analysis Period (min) 15



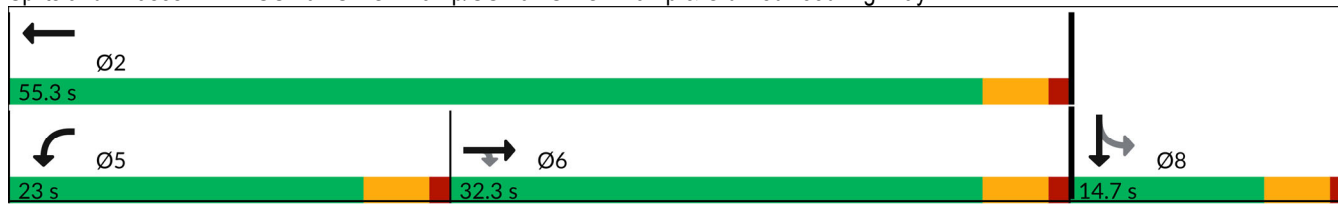



















Splits and Phases: 12: US 101 SB On Ramp/US 101 SB Off Ramp & Old Redwood Highway



Appendix J – General Plan 2040 No Project Conditions  
Intersection Level of Service Worksheets

HCM 6th Signalized Intersection Summary  
 1: Old Redwood Hwy & Shiloh Road

General Plan 2040 Conditions  
 Timing Plan: A.M. PEAK

												
Movement	EBL	EBT	EBR	WBL	WBT	WBR	NBL	NBT	NBR	SBL	SBT	SBR
Lane Configurations												
Traffic Volume (veh/h)	313	140	401	40	123	14	337	308	18	31	473	398
Future Volume (veh/h)	313	140	401	40	123	14	337	308	18	31	473	398
Initial Q (Qb), veh	0	0	0	0	0	0	0	0	0	0	0	0
Ped-Bike Adj(A_pbT)	1.00		1.00	1.00		1.00	1.00		1.00	1.00		0.98
Parking Bus, Adj	1.00	1.00	1.00	1.00	1.00	1.00	1.00	1.00	1.00	1.00	1.00	1.00
Work Zone On Approach		No			No			No			No	
Adj Sat Flow, veh/h/ln	1870	1870	1870	1870	1870	1870	1870	1870	1870	1870	1870	1870
Adj Flow Rate, veh/h	386	173	495	45	138	16	362	331	19	36	556	468
Peak Hour Factor	0.81	0.81	0.81	0.89	0.89	0.89	0.93	0.93	0.93	0.85	0.85	0.85
Percent Heavy Veh, %	2	2	2	2	2	2	2	2	2	2	2	2
Cap, veh/h	492	517	438	56	171	195	234	751	637	81	590	490
Arrive On Green	0.28	0.28	0.28	0.12	0.12	0.12	0.13	0.40	0.40	0.05	0.32	0.32
Sat Flow, veh/h	1781	1870	1585	454	1393	1585	1781	1870	1585	1781	1870	1551
Grp Volume(v), veh/h	386	173	495	183	0	16	362	331	19	36	556	468
Grp Sat Flow(s),veh/h/ln	1781	1870	1585	1848	0	1585	1781	1870	1585	1781	1870	1551
Q Serve(g_s), s	22.1	8.1	30.5	10.6	0.0	1.0	14.5	14.2	0.8	2.2	32.0	32.6
Cycle Q Clear(g_c), s	22.1	8.1	30.5	10.6	0.0	1.0	14.5	14.2	0.8	2.2	32.0	32.6
Prop In Lane	1.00		1.00	0.25		1.00	1.00		1.00	1.00		1.00
Lane Grp Cap(c), veh/h	492	517	438	227	0	195	234	751	637	81	590	490
V/C Ratio(X)	0.78	0.33	1.13	0.81	0.00	0.08	1.55	0.44	0.03	0.45	0.94	0.96
Avail Cap(c_a), veh/h	492	517	438	636	0	545	234	751	637	97	593	492
HCM Platoon Ratio	1.00	1.00	1.00	1.00	1.00	1.00	1.00	1.00	1.00	1.00	1.00	1.00
Upstream Filter(I)	1.00	1.00	1.00	1.00	0.00	1.00	1.00	1.00	1.00	1.00	1.00	1.00
Uniform Delay (d), s/veh	36.9	31.9	40.0	47.1	0.0	42.9	48.0	24.0	20.0	51.4	36.8	37.0
Incr Delay (d2), s/veh	8.1	0.4	83.8	6.6	0.0	0.2	266.7	0.4	0.0	3.8	23.5	29.6
Initial Q Delay(d3),s/veh	0.0	0.0	0.0	0.0	0.0	0.0	0.0	0.0	0.0	0.0	0.0	0.0
%ile BackOfQ(50%),veh/ln	10.4	3.6	21.5	5.2	0.0	0.4	23.5	6.0	0.3	1.0	17.8	15.8
Unsig. Movement Delay, s/veh												
LnGrp Delay(d),s/veh	45.1	32.3	123.8	53.7	0.0	43.1	314.6	24.4	20.0	55.2	60.3	66.6
LnGrp LOS	D	C	F	D	A	D	F	C	C	E	E	E
Approach Vol, veh/h		1054			199			712			1060	
Approach Delay, s/veh		79.9			52.9			171.9			62.9	
Approach LOS		E			D			F			E	
Timer - Assigned Phs		2	3	4		6	7	8				
Phs Duration (G+Y+Rc), s		35.0	18.0	39.4		18.1	8.5	48.9				
Change Period (Y+Rc), s		4.5	3.5	4.5		4.5	3.5	4.5				
Max Green Setting (Gmax), s		30.5	14.5	35.0		38.0	6.0	43.5				
Max Q Clear Time (g_c+I1), s		32.5	16.5	34.6		12.6	4.2	16.2				
Green Ext Time (p_c), s		0.0	0.0	0.2		1.0	0.0	1.8				
<b>Intersection Summary</b>												
HCM 6th Ctrl Delay			93.8									
HCM 6th LOS			F									

HCM 6th Signalized Intersection Summary  
2: Shiloh Road & Hembree Ln

General Plan 2040 Conditions  
Timing Plan: A.M. PEAK



Movement	EBL	EBT	EBR	WBL	WBT	WBR	NBL	NBT	NBR	SBL	SBT	SBR
Lane Configurations												
Traffic Volume (veh/h)	311	709	103	49	719	90	49	11	16	129	18	570
Future Volume (veh/h)	311	709	103	49	719	90	49	11	16	129	18	570
Initial Q (Qb), veh	0	0	0	0	0	0	0	0	0	0	0	0
Ped-Bike Adj(A_pbT)	1.00		1.00	1.00		1.00	1.00		1.00	1.00		1.00
Parking Bus, Adj	1.00	1.00	1.00	1.00	1.00	1.00	1.00	1.00	1.00	1.00	1.00	1.00
Work Zone On Approach		No			No			No			No	
Adj Sat Flow, veh/h/ln	1870	1870	1870	1870	1870	1870	1870	1870	1870	1870	1870	1870
Adj Flow Rate, veh/h	353	806	103	49	741	93	49	11	16	137	18	606
Peak Hour Factor	0.88	0.88	1.00	1.00	0.97	0.97	1.00	1.00	1.00	0.94	1.00	0.94
Percent Heavy Veh, %	2	2	2	2	2	2	2	2	2	2	2	2
Cap, veh/h	468	900	115	76	1464	184	95	37	53	213	28	428
Arrive On Green	0.14	0.55	0.55	0.04	0.46	0.46	0.05	0.05	0.05	0.13	0.13	0.13
Sat Flow, veh/h	3456	1625	208	1781	3177	399	1781	689	1002	1583	208	1585
Grp Volume(v), veh/h	353	0	909	49	414	420	49	0	27	155	0	606
Grp Sat Flow(s),veh/h/ln	1728	0	1833	1781	1777	1799	1781	0	1690	1791	0	1585
Q Serve(g_s), s	7.3	0.0	32.6	2.0	12.2	12.2	2.0	0.0	1.1	6.1	0.0	10.0
Cycle Q Clear(g_c), s	7.3	0.0	32.6	2.0	12.2	12.2	2.0	0.0	1.1	6.1	0.0	10.0
Prop In Lane	1.00		0.11	1.00		0.22	1.00		0.59	0.88		1.00
Lane Grp Cap(c), veh/h	468	0	1015	76	819	829	95	0	90	241	0	428
V/C Ratio(X)	0.75	0.00	0.90	0.64	0.51	0.51	0.52	0.00	0.30	0.64	0.00	1.42
Avail Cap(c_a), veh/h	792	0	1309	132	994	1006	132	0	125	241	0	428
HCM Platoon Ratio	1.00	1.00	1.00	1.00	1.00	1.00	1.00	1.00	1.00	1.00	1.00	1.00
Upstream Filter(I)	1.00	0.00	1.00	1.00	1.00	1.00	1.00	0.00	1.00	1.00	0.00	1.00
Uniform Delay (d), s/veh	30.9	0.0	14.7	35.0	14.1	14.1	34.2	0.0	33.8	30.4	0.0	27.1
Incr Delay (d2), s/veh	2.5	0.0	6.9	8.7	0.5	0.5	4.3	0.0	1.8	5.7	0.0	200.1
Initial Q Delay(d3),s/veh	0.0	0.0	0.0	0.0	0.0	0.0	0.0	0.0	0.0	0.0	0.0	0.0
%ile BackOfQ(50%),veh/ln	3.0	0.0	12.5	1.0	4.3	4.4	1.0	0.0	0.5	2.9	0.0	30.9
Unsig. Movement Delay, s/veh												
LnGrp Delay(d),s/veh	33.4	0.0	21.6	43.6	14.5	14.5	38.5	0.0	35.6	36.1	0.0	227.2
LnGrp LOS	C	A	C	D	B	B	D	A	D	D	A	F
Approach Vol, veh/h		1262			883			76				761
Approach Delay, s/veh		24.9			16.2			37.5				188.3
Approach LOS		C			B			D				F
Timer - Assigned Phs	1	2		4	5	6		8				
Phs Duration (G+Y+Rc), s	7.2	45.1		14.0	14.1	38.2		8.0				
Change Period (Y+Rc), s	4.0	4.0		4.0	4.0	4.0		4.0				
Max Green Setting (Gmax), s	5.5	53.0		10.0	17.0	41.5		5.5				
Max Q Clear Time (g_c+I1), s	4.0	34.6		12.0	9.3	14.2		4.0				
Green Ext Time (p_c), s	0.0	6.5		0.0	0.8	5.4		0.0				

Intersection Summary

HCM 6th Ctrl Delay	64.3
HCM 6th LOS	E



HCM 6th Signalized Intersection Summary  
 3: US 101 NB Off-Ramp & Shiloh Road

General Plan 2040 Conditions  
 Timing Plan: A.M. PEAK



Movement	EBT	EBR	WBL	WBT	NBL	NBR
Lane Configurations	↑↑			↑	↘	↗
Traffic Volume (veh/h)	648	0	0	1006	813	476
Future Volume (veh/h)	648	0	0	1006	813	476
Initial Q (Qb), veh	0	0	0	0	0	0
Ped-Bike Adj(A_pbT)		1.00	1.00		1.00	1.00
Parking Bus, Adj	1.00	1.00	1.00	1.00	1.00	1.00
Work Zone On Approach	No			No	No	
Adj Sat Flow, veh/h/ln	1870	0	0	1870	1870	1870
Adj Flow Rate, veh/h	712	0	0	1118	1070	626
Peak Hour Factor	0.91	0.91	0.90	0.90	0.76	0.76
Percent Heavy Veh, %	2	0	0	2	2	2
Cap, veh/h	1629	0	0	857	767	1201
Arrive On Green	0.46	0.00	0.00	0.46	0.43	0.43
Sat Flow, veh/h	3741	0	0	1870	1781	2790
Grp Volume(v), veh/h	712	0	0	1118	1070	626
Grp Sat Flow(s),veh/h/ln	1777	0	0	1870	1781	1395
Q Serve(g_s), s	9.8	0.0	0.0	33.0	31.0	11.9
Cycle Q Clear(g_c), s	9.8	0.0	0.0	33.0	31.0	11.9
Prop In Lane		0.00	0.00		1.00	1.00
Lane Grp Cap(c), veh/h	1629	0	0	857	767	1201
V/C Ratio(X)	0.44	0.00	0.00	1.30	1.40	0.52
Avail Cap(c_a), veh/h	1629	0	0	857	767	1201
HCM Platoon Ratio	1.00	1.00	1.00	1.00	1.00	1.00
Upstream Filter(I)	1.00	0.00	0.00	1.00	1.00	1.00
Uniform Delay (d), s/veh	13.2	0.0	0.0	19.5	20.5	15.1
Incr Delay (d2), s/veh	0.2	0.0	0.0	145.4	185.7	0.4
Initial Q Delay(d3),s/veh	0.0	0.0	0.0	0.0	0.0	0.0
%ile BackOfQ(50%),veh/ln	3.4	0.0	0.0	46.4	51.0	3.5
Unsig. Movement Delay, s/veh						
LnGrp Delay(d),s/veh	13.4	0.0	0.0	164.9	206.2	15.5
LnGrp LOS	B	A	A	F	F	B
Approach Vol, veh/h	712			1118	1696	
Approach Delay, s/veh	13.4			164.9	135.8	
Approach LOS	B			F	F	
Timer - Assigned Phs		2			6	8
Phs Duration (G+Y+Rc), s		37.0			37.0	35.0
Change Period (Y+Rc), s		4.0			4.0	4.0
Max Green Setting (Gmax), s		33.0			33.0	31.0
Max Q Clear Time (g_c+I1), s		11.8			35.0	33.0
Green Ext Time (p_c), s		4.6			0.0	0.0
<b>Intersection Summary</b>						
HCM 6th Ctrl Delay			120.3			
HCM 6th LOS			F			

HCM Signalized Intersection Capacity Analysis  
 4: Shiloh Road & US 101 SB Off-Ramp

General Plan 2040 Conditions  
 Timing Plan: A.M. PEAK



Movement	EBL	EBT	WBT	WBR	SBL	SBR
Lane Configurations		↑	↑		↘	↗
Traffic Volume (vph)	0	408	1143	0	240	184
Future Volume (vph)	0	408	1143	0	240	184
Ideal Flow (vphpl)	1900	1900	1900	1900	1900	1900
Total Lost time (s)		4.0	4.0		4.0	4.0
Lane Util. Factor		1.00	1.00		1.00	1.00
Frt		1.00	1.00		1.00	0.85
Flt Protected		1.00	1.00		0.95	1.00
Satd. Flow (prot)		1863	1863		1770	1583
Flt Permitted		1.00	1.00		0.95	1.00
Satd. Flow (perm)		1863	1863		1770	1583
Peak-hour factor, PHF	0.93	0.93	0.91	0.91	0.92	0.92
Adj. Flow (vph)	0	439	1256	0	261	200
RTOR Reduction (vph)	0	0	0	0	0	89
Lane Group Flow (vph)	0	439	1256	0	261	111
Turn Type		NA	NA		Perm	Perm
Protected Phases		2	6			
Permitted Phases					4	4
Actuated Green, G (s)		59.3	59.3		15.5	15.5
Effective Green, g (s)		59.3	59.3		15.5	15.5
Actuated g/C Ratio		0.72	0.72		0.19	0.19
Clearance Time (s)		4.0	4.0		4.0	4.0
Vehicle Extension (s)		3.0	3.0		3.0	3.0
Lane Grp Cap (vph)		1334	1334		331	296
v/s Ratio Prot		0.24	c0.67			
v/s Ratio Perm					c0.15	0.07
v/c Ratio		0.33	0.94		0.79	0.38
Uniform Delay, d1		4.4	10.2		32.1	29.4
Progression Factor		1.00	1.00		1.00	1.00
Incremental Delay, d2		0.1	13.1		11.8	0.8
Delay (s)		4.5	23.3		43.9	30.2
Level of Service		A	C		D	C
Approach Delay (s)		4.5	23.3		37.9	
Approach LOS		A	C		D	

Intersection Summary			
HCM 2000 Control Delay		22.6	HCM 2000 Level of Service C
HCM 2000 Volume to Capacity ratio		0.91	
Actuated Cycle Length (s)		82.8	Sum of lost time (s) 8.0
Intersection Capacity Utilization		134.6%	ICU Level of Service H
Analysis Period (min)		15	

c Critical Lane Group

Intersection						
Int Delay, s/veh	5.7					
Movement	EBT	EBR	WBL	WBT	NBL	NBR
Lane Configurations	↑↑		↖	↑	↖	↖
Traffic Vol, veh/h	886	14	130	1197	17	122
Future Vol, veh/h	886	14	130	1197	17	122
Conflicting Peds, #/hr	0	0	0	0	0	0
Sign Control	Free	Free	Free	Free	Stop	Stop
RT Channelized	-	None	-	None	-	None
Storage Length	-	-	68	-	0	0
Veh in Median Storage, #	0	-	-	0	0	-
Grade, %	0	-	-	0	0	-
Peak Hour Factor	96	96	87	87	84	84
Heavy Vehicles, %	2	2	2	2	2	2
Mvmt Flow	923	15	149	1376	20	145

Major/Minor	Major1	Major2	Minor1		
Conflicting Flow All	0	0	938	0	2605 469
Stage 1	-	-	-	-	931 -
Stage 2	-	-	-	-	1674 -
Critical Hdwy	-	-	4.13	-	6.63 6.93
Critical Hdwy Stg 1	-	-	-	-	5.83 -
Critical Hdwy Stg 2	-	-	-	-	5.43 -
Follow-up Hdwy	-	-	2.219	-	3.519 3.319
Pot Cap-1 Maneuver	-	-	728	-	23 542
Stage 1	-	-	-	-	345 -
Stage 2	-	-	-	-	166 -
Platoon blocked, %	-	-	-	-	-
Mov Cap-1 Maneuver	-	-	728	-	~ 18 542
Mov Cap-2 Maneuver	-	-	-	-	~ 18 -
Stage 1	-	-	-	-	345 -
Stage 2	-	-	-	-	132 -



















Approach	EB	WB	NB
HCM Control Delay, s	0	1.1	79.9
HCM LOS			F

Minor Lane/Major Mvmt	NBLn1	NBLn2	EBT	EBR	WBL	WBT
Capacity (veh/h)	18	542	-	-	728	-
HCM Lane V/C Ratio	1.124	0.268	-	-	0.205	-
HCM Control Delay (s)	\$ 552.3	14.1	-	-	11.2	-
HCM Lane LOS	F	B	-	-	B	-
HCM 95th %tile Q(veh)	2.9	1.1	-	-	0.8	-

Notes  
 ~: Volume exceeds capacity    \$: Delay exceeds 300s    +: Computation Not Defined    \*: All major volume in platoon

HCM Signalized Intersection Capacity Analysis  
6: Conde Lane & Shiloh Road

General Plan 2040 Conditions  
Timing Plan: A.M. PEAK

												
Movement	EBL	EBT	EBR	WBL	WBT	WBR	NBL	NBT	NBR	SBL	SBT	SBR
Lane Configurations												
Traffic Volume (vph)	55	521	3	8	844	298	2	1	9	363	0	27
Future Volume (vph)	55	521	3	8	844	298	2	1	9	363	0	27
Ideal Flow (vphpl)	1900	1900	1900	1900	1900	1900	1900	1900	1900	1900	1900	1900
Total Lost time (s)	4.0	4.0		4.0	4.0			4.0			4.0	4.0
Lane Util. Factor	1.00	0.95		1.00	0.95			1.00			1.00	1.00
Frt	1.00	1.00		1.00	0.96			0.90			1.00	0.85
Flt Protected	0.95	1.00		0.95	1.00			0.99			0.95	1.00
Satd. Flow (prot)	1770	3536		1770	3401			1665			1770	1583
Flt Permitted	0.95	1.00		0.95	1.00			0.99			0.95	1.00
Satd. Flow (perm)	1770	3536		1770	3401			1665			1770	1583
Peak-hour factor, PHF	0.95	0.95	0.95	0.85	0.85	0.85	0.57	0.57	0.57	0.86	0.86	0.86
Adj. Flow (vph)	58	548	3	9	993	351	4	2	16	422	0	31
RTOR Reduction (vph)	0	0	0	0	23	0	0	15	0	0	0	0
Lane Group Flow (vph)	58	551	0	9	1321	0	0	7	0	0	422	31
Turn Type	Prot	NA		Prot	NA		Split	NA		Split	NA	custom
Protected Phases	5	2		1	6		7	7		4	4	
Permitted Phases												6
Actuated Green, G (s)	4.6	46.8		1.3	43.5			3.4			11.3	43.5
Effective Green, g (s)	4.6	46.8		1.3	43.5			3.4			11.3	43.5
Actuated g/C Ratio	0.06	0.59		0.02	0.55			0.04			0.14	0.55
Clearance Time (s)	4.0	4.0		4.0	4.0			4.0			4.0	4.0
Vehicle Extension (s)	3.0	3.0		3.0	3.0			3.0			3.0	3.0
Lane Grp Cap (vph)	103	2100		29	1877			71			253	873
v/s Ratio Prot	c0.03	c0.16		0.01	c0.39			c0.00			c0.24	
v/s Ratio Perm												0.02
v/c Ratio	0.56	0.26		0.31	0.70			0.09			1.67	0.04
Uniform Delay, d1	36.1	7.7		38.3	12.9			36.2			33.8	8.1
Progression Factor	1.00	1.00		1.00	1.00			1.00			1.00	1.00
Incremental Delay, d2	6.9	0.1		6.0	1.2			0.6			317.4	0.0
Delay (s)	43.0	7.8		44.3	14.2			36.8			351.2	8.1
Level of Service	D	A		D	B			D			F	A
Approach Delay (s)		11.1			14.4			36.8			327.7	
Approach LOS		B			B			D			F	
<b>Intersection Summary</b>												
HCM 2000 Control Delay			72.0			HCM 2000 Level of Service				E		
HCM 2000 Volume to Capacity ratio			0.82									
Actuated Cycle Length (s)			78.8			Sum of lost time (s)			16.0			
Intersection Capacity Utilization			76.3%			ICU Level of Service			D			
Analysis Period (min)			15									

c Critical Lane Group

HCM 6th TWSC  
7: Entrance 1/Gridley Drive & Shiloh Road

Intersection												
Int Delay, s/veh	1.1											
Movement	EBL	EBT	EBR	WBL	WBT	WBR	NBL	NBT	NBR	SBL	SBT	SBR
Lane Configurations		↕			↕		↕	↕			↕	
Traffic Vol, veh/h	12	208	0	0	86	0	0	0	0	1	0	24
Future Vol, veh/h	12	208	0	0	86	0	0	0	0	1	0	24
Conflicting Peds, #/hr	0	0	0	0	0	0	0	0	0	0	0	0
Sign Control	Free	Free	Free	Free	Free	Free	Stop	Stop	Stop	Stop	Stop	Stop
RT Channelized	-	-	None	-	-	None	-	-	None	-	-	None
Storage Length	-	-	-	-	-	-	0	-	-	-	-	-
Veh in Median Storage, #	-	0	-	-	0	-	-	0	-	-	0	-
Grade, %	-	0	-	-	0	-	-	0	-	-	0	-
Peak Hour Factor	91	91	91	85	85	85	100	100	100	71	71	71
Heavy Vehicles, %	2	2	2	2	2	2	2	2	2	2	2	2
Mvmt Flow	13	229	0	0	101	0	0	0	0	1	0	34

Major/Minor	Major1			Major2			Minor1			Minor2		
Conflicting Flow All	101	0	0	229	0	0	373	356	229	356	356	101
Stage 1	-	-	-	-	-	-	255	255	-	101	101	-
Stage 2	-	-	-	-	-	-	118	101	-	255	255	-
Critical Hdwy	4.12	-	-	4.12	-	-	7.12	6.52	6.22	7.12	6.52	6.22
Critical Hdwy Stg 1	-	-	-	-	-	-	6.12	5.52	-	6.12	5.52	-
Critical Hdwy Stg 2	-	-	-	-	-	-	6.12	5.52	-	6.12	5.52	-
Follow-up Hdwy	2.218	-	-	2.218	-	-	3.518	4.018	3.318	3.518	4.018	3.318
Pot Cap-1 Maneuver	1491	-	-	1339	-	-	584	570	810	599	570	954
Stage 1	-	-	-	-	-	-	749	696	-	905	811	-
Stage 2	-	-	-	-	-	-	887	811	-	749	696	-
Platoon blocked, %		-	-		-	-						
Mov Cap-1 Maneuver	1491	-	-	1339	-	-	559	564	810	594	564	954
Mov Cap-2 Maneuver	-	-	-	-	-	-	559	564	-	594	564	-
Stage 1	-	-	-	-	-	-	742	689	-	896	811	-
Stage 2	-	-	-	-	-	-	856	811	-	742	689	-

Approach	EB	WB	NB	SB
HCM Control Delay, s	0.4	0	0	9
HCM LOS			A	A

Minor Lane/Major Mvmt	NBLn1	NBLn2	EBL	EBT	EBR	WBL	WBT	WBR	SBLn1
Capacity (veh/h)	-	-	1491	-	-	1339	-	-	931
HCM Lane V/C Ratio	-	-	0.009	-	-	-	-	-	0.038
HCM Control Delay (s)	0	0	7.4	0	-	0	-	-	9
HCM Lane LOS	A	A	A	A	-	A	-	-	A
HCM 95th %tile Q(veh)	-	-	0	-	-	0	-	-	0.1

HCM 6th TWSC  
8: Old Redwood Hwy & Entrance 1

Intersection												
Int Delay, s/veh	0.1											
Movement	EBL	EBT	EBR	WBL	WBT	WBR	NBL	NBT	NBR	SBL	SBT	SBR
Lane Configurations		↕		↕	↕			↕		↕	↕	
Traffic Vol, veh/h	1	0	0	0	0	0	0	662	0	0	914	0
Future Vol, veh/h	1	0	0	0	0	0	0	662	0	0	914	0
Conflicting Peds, #/hr	0	0	0	0	0	0	0	0	1	1	0	0
Sign Control	Stop	Stop	Stop	Stop	Stop	Stop	Free	Free	Free	Free	Free	Free
RT Channelized	-	-	None	-	-	None	-	-	None	-	-	None
Storage Length	-	-	-	0	-	-	-	-	-	50	-	-
Veh in Median Storage, #	-	0	-	-	0	-	-	0	-	-	0	-
Grade, %	-	0	-	-	0	-	-	0	-	-	0	-
Peak Hour Factor	25	25	25	100	100	100	99	99	99	90	90	90
Heavy Vehicles, %	2	2	2	2	2	2	2	2	2	2	2	2
Mvmt Flow	4	0	0	0	0	0	0	669	0	0	1016	0

Major/Minor	Minor2		Minor1		Major1		Major2					
Conflicting Flow All	1685	1686	1016	1686	1686	670	1016	0	0	670	0	0
Stage 1	1016	1016	-	670	670	-	-	-	-	-	-	-
Stage 2	669	670	-	1016	1016	-	-	-	-	-	-	-
Critical Hdwy	7.12	6.52	6.22	7.12	6.52	6.22	4.12	-	-	4.12	-	-
Critical Hdwy Stg 1	6.12	5.52	-	6.12	5.52	-	-	-	-	-	-	-
Critical Hdwy Stg 2	6.12	5.52	-	6.12	5.52	-	-	-	-	-	-	-
Follow-up Hdwy	3.518	4.018	3.318	3.518	4.018	3.318	2.218	-	-	2.218	-	-
Pot Cap-1 Maneuver	75	94	289	74	94	457	683	-	-	920	-	-
Stage 1	287	315	-	446	455	-	-	-	-	-	-	-
Stage 2	447	455	-	287	315	-	-	-	-	-	-	-
Platoon blocked, %								-	-	-	-	-
Mov Cap-1 Maneuver	75	94	289	74	94	457	683	-	-	919	-	-
Mov Cap-2 Maneuver	75	94	-	74	94	-	-	-	-	-	-	-
Stage 1	287	315	-	446	455	-	-	-	-	-	-	-
Stage 2	447	455	-	287	315	-	-	-	-	-	-	-

Approach	EB	WB	NB	SB
HCM Control Delay, s	55.7	0	0	0
HCM LOS	F	A		

Minor Lane/Major Mvmt	NBL	NBT	NBR	EBLn1	WBLn1	WBLn2	SBL	SBT	SBR
Capacity (veh/h)	683	-	-	75	-	-	919	-	-
HCM Lane V/C Ratio	-	-	-	0.053	-	-	-	-	-
HCM Control Delay (s)	0	-	-	55.7	0	0	0	-	-
HCM Lane LOS	A	-	-	F	A	A	A	-	-
HCM 95th %tile Q(veh)	0	-	-	0.2	-	-	0	-	-

Intersection						
Int Delay, s/veh	0					
Movement	EBT	EBR	WBL	WBT	NBL	NBR
Lane Configurations	↔			↔	↔	↔
Traffic Vol, veh/h	207	0	0	77	0	0
Future Vol, veh/h	207	0	0	77	0	0
Conflicting Peds, #/hr	0	0	0	0	0	0
Sign Control	Free	Free	Free	Free	Stop	Stop
RT Channelized	-	None	-	None	-	None
Storage Length	-	-	-	-	0	0
Veh in Median Storage, #	0	-	-	0	0	-
Grade, %	0	-	-	0	0	-
Peak Hour Factor	85	85	81	81	100	100
Heavy Vehicles, %	2	2	2	2	2	2
Mvmt Flow	244	0	0	95	0	0

Major/Minor	Major1	Major2	Minor1		
Conflicting Flow All	0	0	244	0	339
Stage 1	-	-	-	-	244
Stage 2	-	-	-	-	95
Critical Hdwy	-	-	4.12	-	6.42
Critical Hdwy Stg 1	-	-	-	-	5.42
Critical Hdwy Stg 2	-	-	-	-	5.42
Follow-up Hdwy	-	-	2.218	-	3.518
Pot Cap-1 Maneuver	-	-	1322	-	657
Stage 1	-	-	-	-	797
Stage 2	-	-	-	-	929
Platoon blocked, %	-	-	-	-	-
Mov Cap-1 Maneuver	-	-	1322	-	657
Mov Cap-2 Maneuver	-	-	-	-	657
Stage 1	-	-	-	-	797
Stage 2	-	-	-	-	929

Approach	EB	WB	NB
HCM Control Delay, s	0	0	0
HCM LOS			A

Minor Lane/Major Mvmt	NBLn1	NBLn2	EBT	EBR	WBL	WBT
Capacity (veh/h)	-	-	-	-	1322	-
HCM Lane V/C Ratio	-	-	-	-	-	-
HCM Control Delay (s)	0	0	-	-	0	-
HCM Lane LOS	A	A	-	-	A	-
HCM 95th %tile Q(veh)	-	-	-	-	0	-

HCM 6th Signalized Intersection Summary  
 10: US 101 NB Off Ramp/Lakewood Drive & Old Redwood Highway

General Plan 2040 Conditions  
 Timing Plan: A.M. PEAK



Movement	EBL	EBT	EBR	WBL	WBT	WBR	NBL	NBT	NBR	SBL	SBT	SBR
Lane Configurations	↔↔	↑			↑↑		↔	↔↔		↔↔		↔
Traffic Volume (veh/h)	264	610	0	0	650	156	224	255	92	255	0	679
Future Volume (veh/h)	264	610	0	0	650	156	224	255	92	255	0	679
Initial Q (Qb), veh	0	0	0	0	0	0	0	0	0	0	0	0
Ped-Bike Adj(A_pbT)	1.00		1.00	1.00		0.99	1.00		1.00	1.00		1.00
Parking Bus, Adj	1.00	1.00	1.00	1.00	1.00	1.00	1.00	1.00	1.00	1.00	1.00	1.00
Work Zone On Approach		No			No			No			No	
Adj Sat Flow, veh/h/ln	1870	1870	0	0	1870	1870	1870	1870	1870	1870	0	1870
Adj Flow Rate, veh/h	311	718	0	0	783	188	211	336	102	287	0	0
Peak Hour Factor	0.85	0.85	0.85	0.83	0.83	0.83	0.90	0.90	0.90	0.89	0.89	0.89
Percent Heavy Veh, %	2	2	0	0	2	2	2	2	2	2	0	2
Cap, veh/h	419	1202	0	0	1296	311	358	555	166	0	0	0
Arrive On Green	0.12	0.64	0.00	0.00	0.46	0.46	0.20	0.20	0.20	0.00	0.00	0.00
Sat Flow, veh/h	3456	1870	0	0	2927	680	1781	2764	825		0	
Grp Volume(v), veh/h	311	718	0	0	491	480	211	226	212		0.0	
Grp Sat Flow(s),veh/h/ln	1728	1870	0	0	1777	1737	1781	1870	1719			
Q Serve(g_s), s	5.4	13.9	0.0	0.0	13.0	13.0	6.7	6.9	7.1			
Cycle Q Clear(g_c), s	5.4	13.9	0.0	0.0	13.0	13.0	6.7	6.9	7.1			
Prop In Lane	1.00		0.00	0.00		0.39	1.00		0.48			
Lane Grp Cap(c), veh/h	419	1202	0	0	813	795	358	375	345			
V/C Ratio(X)	0.74	0.60	0.00	0.00	0.60	0.60	0.59	0.60	0.62			
Avail Cap(c_a), veh/h	497	1202	0	0	813	795	826	867	797			
HCM Platoon Ratio	1.00	1.00	1.00	1.00	1.00	1.00	1.00	1.00	1.00			
Upstream Filter(I)	1.00	1.00	0.00	0.00	1.00	1.00	1.00	1.00	1.00			
Uniform Delay (d), s/veh	26.5	6.5	0.0	0.0	12.7	12.7	22.7	22.7	22.8			
Incr Delay (d2), s/veh	4.9	2.2	0.0	0.0	3.3	3.4	1.6	1.5	1.8			
Initial Q Delay(d3),s/veh	0.0	0.0	0.0	0.0	0.0	0.0	0.0	0.0	0.0			
%ile BackOfQ(50%),veh/ln	2.4	4.3	0.0	0.0	5.0	4.9	2.8	3.0	2.8			
Unsig. Movement Delay, s/veh												
LnGrp Delay(d),s/veh	31.4	8.7	0.0	0.0	16.0	16.1	24.2	24.3	24.6			
LnGrp LOS	C	A	A	A	B	B	C	C	C			
Approach Vol, veh/h		1029			971			649				
Approach Delay, s/veh		15.6			16.1			24.4				
Approach LOS		B			B			C				
Timer - Assigned Phs		2			5	6		8				
Phs Duration (G+Y+Rc), s		45.3			11.6	33.7		17.3				
Change Period (Y+Rc), s		5.1			4.0	5.1		4.7				
Max Green Setting (Gmax), s		40.2			9.0	27.2		29.0				
Max Q Clear Time (g_c+I1), s		15.9			7.4	15.0		9.1				
Green Ext Time (p_c), s		5.2			0.2	4.9		3.2				

Intersection Summary

HCM 6th Ctrl Delay	17.9
HCM 6th LOS	B

Notes

User approved volume balancing among the lanes for turning movement.  
 Unsignalized Delay for [SBR] is excluded from calculations of the approach delay and intersection delay.



HCM 6th Signalized Intersection Summary

General Plan 2040 Conditions

12: US 101 SB On Ramp/US 101 SB Off Ramp & Old Redwood Highway

Timing Plan: A.M. PEAK



Movement	EBL	EBT	EBR	WBL	WBT	WBR	NBL	NBT	NBR	SBL	SBT	SBR
Lane Configurations		↑↑	↗	↘	↑↑					↘	↕	
Traffic Volume (veh/h)	0	699	814	559	742	0	0	0	0	157	0	144
Future Volume (veh/h)	0	699	814	559	742	0	0	0	0	157	0	144
Initial Q (Qb), veh	0	0	0	0	0	0				0	0	0
Ped-Bike Adj(A_pbT)	1.00		0.98	1.00		1.00				1.00		1.00
Parking Bus, Adj	1.00	1.00	1.00	1.00	1.00	1.00				1.00	1.00	1.00
Work Zone On Approach		No			No						No	
Adj Sat Flow, veh/h/ln	0	1870	1870	1870	1870	0				1870	1870	1870
Adj Flow Rate, veh/h	0	760	885	628	834	0				186	11	0
Peak Hour Factor	0.92	0.92	0.92	0.89	0.89	0.89				0.81	0.81	0.81
Percent Heavy Veh, %	0	2	2	2	2	0				2	2	2
Cap, veh/h	0	1208	530	646	2674	0				223	234	
Arrive On Green	0.00	0.34	0.34	0.36	0.75	0.00				0.13	0.13	0.00
Sat Flow, veh/h	0	3647	1560	1781	3647	0				1781	1870	0
Grp Volume(v), veh/h	0	760	885	628	834	0				186	11	0
Grp Sat Flow(s),veh/h/ln	0	1777	1560	1781	1777	0				1781	1870	0
Q Serve(g_s), s	0.0	14.4	27.2	27.8	6.1	0.0				8.2	0.4	0.0
Cycle Q Clear(g_c), s	0.0	14.4	27.2	27.8	6.1	0.0				8.2	0.4	0.0
Prop In Lane	0.00		1.00	1.00		0.00				1.00		0.00
Lane Grp Cap(c), veh/h	0	1208	530	646	2674	0				223	234	
V/C Ratio(X)	0.00	0.63	1.67	0.97	0.31	0.00				0.84	0.05	
Avail Cap(c_a), veh/h	0	1208	530	646	2674	0				223	234	
HCM Platoon Ratio	1.00	1.00	1.00	1.00	1.00	1.00				1.00	1.00	1.00
Upstream Filter(I)	0.00	1.00	1.00	1.00	1.00	0.00				1.00	1.00	0.00
Uniform Delay (d), s/veh	0.0	22.2	26.4	25.1	3.2	0.0				34.2	30.8	0.0
Incr Delay (d2), s/veh	0.0	2.5	309.2	28.5	0.3	0.0				23.2	0.1	0.0
Initial Q Delay(d3),s/veh	0.0	0.0	0.0	0.0	0.0	0.0				0.0	0.0	0.0
%ile BackOfQ(50%),veh/ln	0.0	6.0	54.8	15.8	1.4	0.0				4.9	0.2	0.0
Unsig. Movement Delay, s/veh												
LnGrp Delay(d),s/veh	0.0	24.7	335.6	53.7	3.5	0.0				57.4	30.9	0.0
LnGrp LOS	A	C	F	D	A	A				E	C	
Approach Vol, veh/h		1645			1462						197	
Approach Delay, s/veh		191.9			25.0						55.9	
Approach LOS		F			C						E	
Timer - Assigned Phs		2			5	6		8				
Phs Duration (G+Y+Rc), s		65.3			33.0	32.3		14.7				
Change Period (Y+Rc), s		5.1			4.0	5.1		4.7				
Max Green Setting (Gmax), s		60.2			29.0	27.2		10.0				
Max Q Clear Time (g_c+I1), s		8.1			29.8	29.2		10.2				
Green Ext Time (p_c), s		6.9			0.0	0.0		0.0				

Intersection Summary























HCM 6th Ctrl Delay	110.0
HCM 6th LOS	F

Notes

- User approved volume balancing among the lanes for turning movement.
- User approved ignoring U-Turning movement.
- Unsignalized Delay for [SBR] is excluded from calculations of the approach delay and intersection delay.

























HCM 6th Signalized Intersection Summary  
 1: Old Redwood Hwy & Shiloh Road

General Plan 2040 Conditions  
 Timing Plan: P.M. Peak

												
Movement	EBL	EBT	EBR	WBL	WBT	WBR	NBL	NBT	NBR	SBL	SBT	SBR
Lane Configurations												
Traffic Volume (veh/h)	317	125	572	44	139	31	598	557	44	43	536	265
Future Volume (veh/h)	317	125	572	44	139	31	598	557	44	43	536	265
Initial Q (Qb), veh	0	0	0	0	0	0	0	0	0	0	0	0
Ped-Bike Adj(A_pbT)	1.00		1.00	1.00		1.00	1.00		0.98	1.00		0.97
Parking Bus, Adj	1.00	1.00	1.00	1.00	1.00	1.00	1.00	1.00	1.00	1.00	1.00	1.00
Work Zone On Approach		No			No			No			No	
Adj Sat Flow, veh/h/ln	1870	1870	1870	1870	1870	1870	1870	1870	1870	1870	1870	1870
Adj Flow Rate, veh/h	327	129	590	48	153	34	643	599	47	46	576	285
Peak Hour Factor	0.97	0.97	0.97	0.91	0.91	0.91	0.93	0.93	0.93	0.93	0.93	0.93
Percent Heavy Veh, %	2	2	2	2	2	2	2	2	2	2	2	2
Cap, veh/h	484	508	430	60	192	215	230	741	613	79	583	482
Arrive On Green	0.27	0.27	0.27	0.14	0.14	0.14	0.13	0.40	0.40	0.04	0.31	0.31
Sat Flow, veh/h	1781	1870	1582	441	1407	1579	1781	1870	1547	1781	1870	1545
Grp Volume(v), veh/h	327	129	590	201	0	34	643	599	47	46	576	285
Grp Sat Flow(s),veh/h/ln	1781	1870	1582	1848	0	1579	1781	1870	1547	1781	1870	1545
Q Serve(g_s), s	18.4	6.1	30.5	11.8	0.0	2.1	14.5	32.0	2.1	2.8	34.4	17.5
Cycle Q Clear(g_c), s	18.4	6.1	30.5	11.8	0.0	2.1	14.5	32.0	2.1	2.8	34.4	17.5
Prop In Lane	1.00		1.00	0.24		1.00	1.00		1.00	1.00		1.00
Lane Grp Cap(c), veh/h	484	508	430	252	0	215	230	741	613	79	583	482
V/C Ratio(X)	0.68	0.25	1.37	0.80	0.00	0.16	2.80	0.81	0.08	0.58	0.99	0.59
Avail Cap(c_a), veh/h	484	508	430	625	0	534	230	741	613	95	583	482
HCM Platoon Ratio	1.00	1.00	1.00	1.00	1.00	1.00	1.00	1.00	1.00	1.00	1.00	1.00
Upstream Filter(I)	1.00	1.00	1.00	1.00	0.00	1.00	1.00	1.00	1.00	1.00	1.00	1.00
Uniform Delay (d), s/veh	36.5	32.0	40.9	47.0	0.0	42.8	48.9	30.1	21.1	52.6	38.5	32.6
Incr Delay (d2), s/veh	3.7	0.3	182.2	5.7	0.0	0.3	820.2	6.7	0.1	6.5	34.2	1.9
Initial Q Delay(d3),s/veh	0.0	0.0	0.0	0.0	0.0	0.0	0.0	0.0	0.0	0.0	0.0	0.0
%ile BackOfQ(50%),veh/ln	8.3	2.7	33.0	5.7	0.0	0.8	58.6	14.8	0.7	1.4	20.6	6.6
Unsig. Movement Delay, s/veh												
LnGrp Delay(d),s/veh	40.2	32.3	223.1	52.7	0.0	43.1	869.1	36.8	21.2	59.2	72.6	34.6
LnGrp LOS	D	C	F	D	A	D	F	D	C	E	E	C
Approach Vol, veh/h		1046			235			1289			907	
Approach Delay, s/veh		142.4			51.3			451.4			60.0	
Approach LOS		F			D			F			E	
Timer - Assigned Phs		2	3	4		6	7	8				
Phs Duration (G+Y+Rc), s		35.0	18.0	39.5		19.8	8.5	49.0				
Change Period (Y+Rc), s		4.5	3.5	4.5		4.5	3.5	4.5				
Max Green Setting (Gmax), s		30.5	14.5	35.0		38.0	6.0	43.5				
Max Q Clear Time (g_c+I1), s		32.5	16.5	36.4		13.8	4.8	34.0				
Green Ext Time (p_c), s		0.0	0.0	0.0		1.1	0.0	2.6				
<b>Intersection Summary</b>												
HCM 6th Ctrl Delay			229.3									
HCM 6th LOS			F									

HCM 6th Signalized Intersection Summary  
 2: Shiloh Road & Hembree Ln

General Plan 2040 Conditions  
 Timing Plan: P.M. Peak

												
Movement	EBL	EBT	EBR	WBL	WBT	WBR	NBL	NBT	NBR	SBL	SBT	SBR
Lane Configurations	 			 	 						 	 
Traffic Volume (veh/h)	661	811	69	110	774	118	111	21	128	174	11	526
Future Volume (veh/h)	661	811	69	110	774	118	111	21	128	174	11	526
Initial Q (Qb), veh	0	0	0	0	0	0	0	0	0	0	0	0
Ped-Bike Adj(A_pbT)	1.00		1.00	1.00		1.00	1.00		1.00	1.00		1.00
Parking Bus, Adj	1.00	1.00	1.00	1.00	1.00	1.00	1.00	1.00	1.00	1.00	1.00	1.00
Work Zone On Approach		No			No			No			No	
Adj Sat Flow, veh/h/ln	1870	1870	1870	1870	1870	1870	1870	1870	1870	1870	1870	1870
Adj Flow Rate, veh/h	703	863	69	110	890	136	111	21	128	183	11	554
Peak Hour Factor	0.94	0.94	1.00	1.00	0.87	0.87	1.00	1.00	1.00	0.95	1.00	0.95
Percent Heavy Veh, %	2	2	2	2	2	2	2	2	2	2	2	2
Cap, veh/h	713	941	75	119	1270	194	119	15	93	205	12	520
Arrive On Green	0.21	0.55	0.55	0.07	0.41	0.41	0.07	0.07	0.07	0.12	0.12	0.12
Sat Flow, veh/h	3456	1709	137	1781	3089	472	1781	228	1392	1685	101	1585
Grp Volume(v), veh/h	703	0	932	110	512	514	111	0	149	194	0	554
Grp Sat Flow(s),veh/h/ln	1728	0	1846	1781	1777	1785	1781	0	1620	1786	0	1585
Q Serve(g_s), s	16.7	0.0	37.7	5.1	19.6	19.6	5.1	0.0	5.5	8.8	0.0	10.0
Cycle Q Clear(g_c), s	16.7	0.0	37.7	5.1	19.6	19.6	5.1	0.0	5.5	8.8	0.0	10.0
Prop In Lane	1.00		0.07	1.00		0.26	1.00		0.86	0.94		1.00
Lane Grp Cap(c), veh/h	713	0	1016	119	730	734	119	0	108	217	0	520
V/C Ratio(X)	0.99	0.00	0.92	0.92	0.70	0.70	0.93	0.00	1.38	0.89	0.00	1.07
Avail Cap(c_a), veh/h	713	0	1188	119	895	899	119	0	108	217	0	520
HCM Platoon Ratio	1.00	1.00	1.00	1.00	1.00	1.00	1.00	1.00	1.00	1.00	1.00	1.00
Upstream Filter(I)	1.00	0.00	1.00	1.00	1.00	1.00	1.00	0.00	1.00	1.00	0.00	1.00
Uniform Delay (d), s/veh	32.6	0.0	16.8	38.2	20.1	20.1	38.2	0.0	38.4	35.7	0.0	27.7
Incr Delay (d2), s/veh	30.0	0.0	10.2	59.5	1.9	1.9	61.8	0.0	217.3	34.2	0.0	58.3
Initial Q Delay(d3),s/veh	0.0	0.0	0.0	0.0	0.0	0.0	0.0	0.0	0.0	0.0	0.0	0.0
%ile BackOfQ(50%),veh/ln	9.5	0.0	15.9	4.1	7.6	7.7	4.2	0.0	8.7	5.8	0.0	18.1
Unsig. Movement Delay, s/veh												
LnGrp Delay(d),s/veh	62.5	0.0	27.0	97.7	21.9	21.9	100.1	0.0	255.7	69.8	0.0	86.0
LnGrp LOS	E	A	C	F	C	C	F	A	F	E	A	F
Approach Vol, veh/h		1635			1136			260			748	
Approach Delay, s/veh		42.3			29.3			189.3			81.8	
Approach LOS		D			C			F			F	
Timer - Assigned Phs	1	2		4	5	6		8				
Phs Duration (G+Y+Rc), s	9.5	49.4		14.0	21.0	37.9		9.5				
Change Period (Y+Rc), s	4.0	4.0		4.0	4.0	4.0		4.0				
Max Green Setting (Gmax), s	5.5	53.0		10.0	17.0	41.5		5.5				
Max Q Clear Time (g_c+I1), s	7.1	39.7		12.0	18.7	21.6		7.5				
Green Ext Time (p_c), s	0.0	5.6		0.0	0.0	6.4		0.0				
<b>Intersection Summary</b>												
HCM 6th Ctrl Delay				56.3								
HCM 6th LOS				E								

HCM 6th Signalized Intersection Summary  
 3: US 101 NB Off-Ramp & Shiloh Road

General Plan 2040 Conditions  
 Timing Plan: P.M. Peak



Movement	EBT	EBR	WBL	WBT	NBL	NBR
Lane Configurations	↑↑			↑	↘	↗
Traffic Volume (veh/h)	761	0	0	871	694	737
Future Volume (veh/h)	761	0	0	871	694	737
Initial Q (Qb), veh	0	0	0	0	0	0
Ped-Bike Adj(A_pbT)		1.00	1.00		1.00	1.00
Parking Bus, Adj	1.00	1.00	1.00	1.00	1.00	1.00
Work Zone On Approach	No			No	No	
Adj Sat Flow, veh/h/ln	1870	0	0	1870	1870	1870
Adj Flow Rate, veh/h	810	0	0	898	771	819
Peak Hour Factor	0.94	0.94	0.97	0.97	0.90	0.90
Percent Heavy Veh, %	2	0	0	2	2	2
Cap, veh/h	1629	0	0	857	767	1201
Arrive On Green	0.46	0.00	0.00	0.46	0.43	0.43
Sat Flow, veh/h	3741	0	0	1870	1781	2790
Grp Volume(v), veh/h	810	0	0	898	771	819
Grp Sat Flow(s),veh/h/ln	1777	0	0	1870	1781	1395
Q Serve(g_s), s	11.5	0.0	0.0	33.0	31.0	17.0
Cycle Q Clear(g_c), s	11.5	0.0	0.0	33.0	31.0	17.0
Prop In Lane		0.00	0.00		1.00	1.00
Lane Grp Cap(c), veh/h	1629	0	0	857	767	1201
V/C Ratio(X)	0.50	0.00	0.00	1.05	1.01	0.68
Avail Cap(c_a), veh/h	1629	0	0	857	767	1201
HCM Platoon Ratio	1.00	1.00	1.00	1.00	1.00	1.00
Upstream Filter(I)	1.00	0.00	0.00	1.00	1.00	1.00
Uniform Delay (d), s/veh	13.7	0.0	0.0	19.5	20.5	16.5
Incr Delay (d2), s/veh	0.2	0.0	0.0	43.9	33.8	1.6
Initial Q Delay(d3),s/veh	0.0	0.0	0.0	0.0	0.0	0.0
%ile BackOfQ(50%),veh/ln	4.0	0.0	0.0	22.3	18.6	5.2
Unsig. Movement Delay, s/veh						
LnGrp Delay(d),s/veh	13.9	0.0	0.0	63.4	54.3	18.1
LnGrp LOS	B	A	A	F	F	B
Approach Vol, veh/h	810			898	1590	
Approach Delay, s/veh	13.9			63.4	35.7	
Approach LOS	B			E	D	
Timer - Assigned Phs		2			6	8
Phs Duration (G+Y+Rc), s		37.0			37.0	35.0
Change Period (Y+Rc), s		4.0			4.0	4.0
Max Green Setting (Gmax), s		33.0			33.0	31.0
Max Q Clear Time (g_c+I1), s		13.5			35.0	33.0
Green Ext Time (p_c), s		5.2			0.0	0.0
<b>Intersection Summary</b>						
HCM 6th Ctrl Delay			37.9			
HCM 6th LOS			D			

HCM Signalized Intersection Capacity Analysis  
4: Shiloh Road & US 101 SB Off-Ramp

General Plan 2040 Conditions  
Timing Plan: P.M. Peak



Movement	EBL	EBT	WBT	WBR	SBL	SBR
Lane Configurations		↑	↑		↙	↗
Traffic Volume (vph)	0	637	1059	0	322	94
Future Volume (vph)	0	637	1059	0	322	94
Ideal Flow (vphpl)	1900	1900	1900	1900	1900	1900
Total Lost time (s)		4.0	4.0		4.0	4.0
Lane Util. Factor		1.00	1.00		1.00	1.00
Frbp, ped/bikes		1.00	1.00		1.00	0.98
Flpb, ped/bikes		1.00	1.00		1.00	1.00
Frt		1.00	1.00		1.00	0.85
Flt Protected		1.00	1.00		0.95	1.00
Satd. Flow (prot)		1863	1863		1770	1548
Flt Permitted		1.00	1.00		0.95	1.00
Satd. Flow (perm)		1863	1863		1770	1548
Peak-hour factor, PHF	0.89	0.89	0.96	0.96	0.93	0.93
Adj. Flow (vph)	0	716	1103	0	346	101
RTOR Reduction (vph)	0	0	0	0	0	77
Lane Group Flow (vph)	0	716	1103	0	346	24
Confl. Peds. (#/hr)						1
Turn Type		NA	NA		Perm	Perm
Protected Phases		2	6			
Permitted Phases					4	4
Actuated Green, G (s)		48.9	48.9		17.6	17.6
Effective Green, g (s)		48.9	48.9		17.6	17.6
Actuated g/C Ratio		0.66	0.66		0.24	0.24
Clearance Time (s)		4.0	4.0		4.0	4.0
Vehicle Extension (s)		3.0	3.0		3.0	3.0
Lane Grp Cap (vph)		1222	1222		418	365
v/s Ratio Prot		0.38	c0.59			
v/s Ratio Perm					c0.20	0.02
v/c Ratio		0.59	0.90		0.83	0.07
Uniform Delay, d1		7.1	10.8		27.0	22.1
Progression Factor		1.00	1.00		1.00	1.00
Incremental Delay, d2		0.7	9.4		12.7	0.1
Delay (s)		7.9	20.2		39.7	22.1
Level of Service		A	C		D	C
Approach Delay (s)		7.9	20.2		35.7	
Approach LOS		A	C		D	
<b>Intersection Summary</b>						
HCM 2000 Control Delay			19.4		HCM 2000 Level of Service	B
HCM 2000 Volume to Capacity ratio			0.88			
Actuated Cycle Length (s)			74.5		Sum of lost time (s)	8.0
Intersection Capacity Utilization			150.2%		ICU Level of Service	H
Analysis Period (min)			15			
c Critical Lane Group						

Intersection						
Int Delay, s/veh	7.4					
Movement	EBT	EBR	WBL	WBT	NBL	NBR
Lane Configurations	↑↑		↖	↑	↖	↖
Traffic Vol, veh/h	1179	16	105	1118	18	159
Future Vol, veh/h	1179	16	105	1118	18	159
Conflicting Peds, #/hr	0	0	0	0	0	0
Sign Control	Free	Free	Free	Free	Stop	Stop
RT Channelized	-	None	-	None	-	None
Storage Length	-	-	68	-	0	0
Veh in Median Storage, #	0	-	-	0	0	-
Grade, %	0	-	-	0	0	-
Peak Hour Factor	89	89	92	92	89	89
Heavy Vehicles, %	2	2	2	2	2	2
Mvmt Flow	1325	18	114	1215	20	179

Major/Minor	Major1	Major2	Minor1		
Conflicting Flow All	0	0	1343	0	2777 672
Stage 1	-	-	-	-	1334 -
Stage 2	-	-	-	-	1443 -
Critical Hdwy	-	-	4.13	-	6.63 6.93
Critical Hdwy Stg 1	-	-	-	-	5.83 -
Critical Hdwy Stg 2	-	-	-	-	5.43 -
Follow-up Hdwy	-	-	2.219	-	3.519 3.319
Pot Cap-1 Maneuver	-	-	511	-	~ 18 399
Stage 1	-	-	-	-	211 -
Stage 2	-	-	-	-	217 -
Platoon blocked, %	-	-	-	-	-
Mov Cap-1 Maneuver	-	-	511	-	~ 14 399
Mov Cap-2 Maneuver	-	-	-	-	~ 14 -
Stage 1	-	-	-	-	211 -
Stage 2	-	-	-	-	169 -



















Approach	EB	WB	NB
HCM Control Delay, s	0	1.2	98.6
HCM LOS			F

Minor Lane/Major Mvmt	NBLn1	NBLn2	EBT	EBR	WBL	WBT
Capacity (veh/h)	14	399	-	-	511	-
HCM Lane V/C Ratio	1.445	0.448	-	-	0.223	-
HCM Control Delay (s)	\$ 783.1	21.1	-	-	14.1	-
HCM Lane LOS	F	C	-	-	B	-
HCM 95th %tile Q(veh)	3.2	2.2	-	-	0.8	-

Notes  
 ~: Volume exceeds capacity    \$: Delay exceeds 300s    +: Computation Not Defined    \*: All major volume in platoon

HCM Signalized Intersection Capacity Analysis  
6: Conde Lane & Shiloh Road

General Plan 2040 Conditions  
Timing Plan: P.M. Peak

												
Movement	EBL	EBT	EBR	WBL	WBT	WBR	NBL	NBT	NBR	SBL	SBT	SBR
Lane Configurations												
Traffic Volume (vph)	77	702	0	9	722	372	4	2	16	387	4	65
Future Volume (vph)	77	702	0	9	722	372	4	2	16	387	4	65
Ideal Flow (vphp)	1900	1900	1900	1900	1900	1900	1900	1900	1900	1900	1900	1900
Total Lost time (s)	4.0	4.0		4.0	4.0			4.0			4.0	4.0
Lane Util. Factor	1.00	0.95		1.00	0.95			1.00			1.00	1.00
Frbp, ped/bikes	1.00	1.00		1.00	0.99			1.00			1.00	1.00
Flpb, ped/bikes	1.00	1.00		1.00	1.00			1.00			1.00	1.00
Frt	1.00	1.00		1.00	0.95			0.90			1.00	0.85
Flt Protected	0.95	1.00		0.95	1.00			0.99			0.95	1.00
Satd. Flow (prot)	1770	3539		1770	3335			1663			1775	1583
Flt Permitted	0.95	1.00		0.95	1.00			0.99			0.95	1.00
Satd. Flow (perm)	1770	3539		1770	3335			1663			1775	1583
Peak-hour factor, PHF	0.88	0.88	0.88	0.80	0.80	0.80	0.63	0.63	0.63	0.88	0.88	0.88
Adj. Flow (vph)	88	798	0	11	902	465	6	3	25	440	5	74
RTOR Reduction (vph)	0	0	0	0	45	0	0	23	0	0	0	0
Lane Group Flow (vph)	88	798	0	11	1323	0	0	11	0	0	445	74
Confl. Peds. (#/hr)	1					1						
Turn Type	Prot	NA		Prot	NA		Split	NA		Split	NA	custom
Protected Phases	5	2		1	6		7	7		4	4	
Permitted Phases												6
Actuated Green, G (s)	6.6	49.4		1.4	44.2			5.4			11.2	44.2
Effective Green, g (s)	6.6	49.4		1.4	44.2			5.4			11.2	44.2
Actuated g/C Ratio	0.08	0.59		0.02	0.53			0.06			0.13	0.53
Clearance Time (s)	4.0	4.0		4.0	4.0			4.0			4.0	4.0
Vehicle Extension (s)	3.0	3.0		3.0	3.0			3.0			3.0	3.0
Lane Grp Cap (vph)	140	2096		29	1767			107			238	838
v/s Ratio Prot	c0.05	0.23		0.01	c0.40			c0.01			c0.25	
v/s Ratio Perm												0.05
v/c Ratio	0.63	0.38		0.38	0.75			0.10			1.87	0.09
Uniform Delay, d1	37.2	8.9		40.6	15.3			36.7			36.1	9.7
Progression Factor	1.00	1.00		1.00	1.00			1.00			1.00	1.00
Incremental Delay, d2	8.5	0.1		8.1	1.8			0.4			407.0	0.0
Delay (s)	45.7	9.1		48.7	17.1			37.1			443.1	9.7
Level of Service	D	A		D	B			D			F	A
Approach Delay (s)		12.7			17.3			37.1			381.3	
Approach LOS		B			B			D			F	
<b>Intersection Summary</b>												
HCM 2000 Control Delay			83.1			HCM 2000 Level of Service			F			
HCM 2000 Volume to Capacity ratio			0.87									
Actuated Cycle Length (s)			83.4			Sum of lost time (s)		16.0				
Intersection Capacity Utilization			76.9%			ICU Level of Service		D				
Analysis Period (min)			15									
c Critical Lane Group												

HCM 6th TWSC  
7: Entrance 1/Gridley Drive & Shiloh Road

General Plan 2040 Conditions  
Timing Plan: P.M. Peak

Intersection												
Int Delay, s/veh	1.1											
Movement	EBL	EBT	EBR	WBL	WBT	WBR	NBL	NBT	NBR	SBL	SBT	SBR
Lane Configurations		↕			↕		↕	↕			↕	
Traffic Vol, veh/h	25	152	0	0	185	0	0	0	0	0	0	21
Future Vol, veh/h	25	152	0	0	185	0	0	0	0	0	0	21
Conflicting Peds, #/hr	1	0	0	0	0	0	0	0	0	0	0	0
Sign Control	Free	Free	Free	Free	Free	Free	Stop	Stop	Stop	Stop	Stop	Stop
RT Channelized	-	-	None	-	-	None	-	-	None	-	-	None
Storage Length	-	-	-	-	-	-	0	-	-	-	-	-
Veh in Median Storage, #	-	0	-	-	0	-	-	0	-	-	0	-
Grade, %	-	0	-	-	0	-	-	0	-	-	0	-
Peak Hour Factor	94	94	94	69	69	69	100	100	100	58	58	58
Heavy Vehicles, %	2	2	2	2	2	2	2	2	2	2	2	2
Mvmt Flow	27	162	0	0	268	0	0	0	0	0	0	36

Major/Minor	Major1			Major2			Minor1			Minor2		
Conflicting Flow All	269	0	0	162	0	0	502	485	162	485	485	269
Stage 1	-	-	-	-	-	-	216	216	-	269	269	-
Stage 2	-	-	-	-	-	-	286	269	-	216	216	-
Critical Hdwy	4.12	-	-	4.12	-	-	7.12	6.52	6.22	7.12	6.52	6.22
Critical Hdwy Stg 1	-	-	-	-	-	-	6.12	5.52	-	6.12	5.52	-
Critical Hdwy Stg 2	-	-	-	-	-	-	6.12	5.52	-	6.12	5.52	-
Follow-up Hdwy	2.218	-	-	2.218	-	-	3.518	4.018	3.318	3.518	4.018	3.318
Pot Cap-1 Maneuver	1295	-	-	1417	-	-	480	482	883	492	482	770
Stage 1	-	-	-	-	-	-	786	724	-	737	687	-
Stage 2	-	-	-	-	-	-	721	687	-	786	724	-
Platoon blocked, %		-	-		-	-						
Mov Cap-1 Maneuver	1294	-	-	1417	-	-	449	470	883	483	470	769
Mov Cap-2 Maneuver	-	-	-	-	-	-	449	470	-	483	470	-
Stage 1	-	-	-	-	-	-	768	707	-	719	686	-
Stage 2	-	-	-	-	-	-	687	686	-	768	707	-

Approach	EB	WB	NB	SB
HCM Control Delay, s	1.1	0	0	9.9
HCM LOS			A	A

Minor Lane/Major Mvmt	NBLn1	NBLn2	EBL	EBT	EBR	WBL	WBT	WBR	SBLn1
Capacity (veh/h)	-	-	1294	-	-	1417	-	-	769
HCM Lane V/C Ratio	-	-	0.021	-	-	-	-	-	0.047
HCM Control Delay (s)	0	0	7.8	0	-	0	-	-	9.9
HCM Lane LOS	A	A	A	A	-	A	-	-	A
HCM 95th %tile Q(veh)	-	-	0.1	-	-	0	-	-	0.1



HCM 6th TWSC  
8: Old Redwood Hwy & Entrance 1

Intersection												
Int Delay, s/veh	1.5											
Movement	EBL	EBT	EBR	WBL	WBT	WBR	NBL	NBT	NBR	SBL	SBT	SBR
Lane Configurations		↕		↕	↕			↕		↕	↕	
Traffic Vol, veh/h	4	0	0	0	0	0	0	1195	0	0	1152	0
Future Vol, veh/h	4	0	0	0	0	0	0	1195	0	0	1152	0
Conflicting Peds, #/hr	0	0	0	0	0	0	0	0	0	0	0	0
Sign Control	Stop	Stop	Stop	Stop	Stop	Stop	Free	Free	Free	Free	Free	Free
RT Channelized	-	-	None	-	-	None	-	-	None	-	-	None
Storage Length	-	-	-	0	-	-	-	-	-	50	-	-
Veh in Median Storage, #	-	0	-	-	0	-	-	0	-	-	0	-
Grade, %	-	0	-	-	0	-	-	0	-	-	0	-
Peak Hour Factor	38	38	38	100	100	100	91	91	91	94	94	94
Heavy Vehicles, %	2	2	2	2	2	2	2	2	2	2	2	2
Mvmt Flow	11	0	0	0	0	0	0	1313	0	0	1226	0

Major/Minor	Minor2		Minor1		Major1		Major2					
Conflicting Flow All	2539	2539	1226	2539	2539	1313	1226	0	0	1313	0	0
Stage 1	1226	1226	-	1313	1313	-	-	-	-	-	-	-
Stage 2	1313	1313	-	1226	1226	-	-	-	-	-	-	-
Critical Hdwy	7.12	6.52	6.22	7.12	6.52	6.22	4.12	-	-	4.12	-	-
Critical Hdwy Stg 1	6.12	5.52	-	6.12	5.52	-	-	-	-	-	-	-
Critical Hdwy Stg 2	6.12	5.52	-	6.12	5.52	-	-	-	-	-	-	-
Follow-up Hdwy	3.518	4.018	3.318	3.518	4.018	3.318	2.218	-	-	2.218	-	-
Pot Cap-1 Maneuver	18	27	218	18	27	194	569	-	-	527	-	-
Stage 1	218	251	-	195	228	-	-	-	-	-	-	-
Stage 2	195	228	-	218	251	-	-	-	-	-	-	-
Platoon blocked, %	-	-	-	-	-	-	-	-	-	-	-	-
Mov Cap-1 Maneuver	18	27	218	18	27	194	569	-	-	527	-	-
Mov Cap-2 Maneuver	18	27	-	18	27	-	-	-	-	-	-	-
Stage 1	218	251	-	195	228	-	-	-	-	-	-	-
Stage 2	195	228	-	218	251	-	-	-	-	-	-	-

Approach	EB	WB	NB	SB
HCM Control Delay, s	359.3	0	0	0
HCM LOS	F	A		

Minor Lane/Major Mvmt	NBL	NBT	NBR	EBLn1	WBLn1	WBLn2	SBL	SBT	SBR
Capacity (veh/h)	569	-	-	18	-	-	527	-	-
HCM Lane V/C Ratio	-	-	-	0.585	-	-	-	-	-
HCM Control Delay (s)	0	-	-	359.3	0	0	0	-	-
HCM Lane LOS	A	-	-	F	A	A	A	-	-
HCM 95th %tile Q(veh)	0	-	-	1.6	-	-	0	-	-

Notes  
 ~: Volume exceeds capacity    \$: Delay exceeds 300s    +: Computation Not Defined    \*: All major volume in platoon

Intersection						
Int Delay, s/veh	0					
Movement	EBT	EBR	WBL	WBT	NBL	NBR
Lane Configurations						
Traffic Vol, veh/h	120	0	0	164	0	0
Future Vol, veh/h	120	0	0	164	0	0
Conflicting Peds, #/hr	0	0	0	0	0	0
Sign Control	Free	Free	Free	Free	Stop	Stop
RT Channelized	-	None	-	None	-	None
Storage Length	-	-	-	-	0	0
Veh in Median Storage, #	0	-	-	0	0	-
Grade, %	0	-	-	0	0	-
Peak Hour Factor	92	92	68	68	100	100
Heavy Vehicles, %	2	2	2	2	2	2
Mvmt Flow	130	0	0	241	0	0

Major/Minor	Major1	Major2	Minor1		
Conflicting Flow All	0	0	130	0	371
Stage 1	-	-	-	-	130
Stage 2	-	-	-	-	241
Critical Hdwy	-	-	4.12	-	6.42
Critical Hdwy Stg 1	-	-	-	-	5.42
Critical Hdwy Stg 2	-	-	-	-	5.42
Follow-up Hdwy	-	-	2.218	-	3.518
Pot Cap-1 Maneuver	-	-	1455	-	630
Stage 1	-	-	-	-	896
Stage 2	-	-	-	-	799
Platoon blocked, %	-	-	-	-	-
Mov Cap-1 Maneuver	-	-	1455	-	630
Mov Cap-2 Maneuver	-	-	-	-	630
Stage 1	-	-	-	-	896
Stage 2	-	-	-	-	799

Approach	EB	WB	NB
HCM Control Delay, s	0	0	0
HCM LOS			A

Minor Lane/Major Mvmt	NBLn1	NBLn2	EBT	EBR	WBL	WBT
Capacity (veh/h)	-	-	-	-	1455	-
HCM Lane V/C Ratio	-	-	-	-	-	-
HCM Control Delay (s)	0	0	-	-	0	-
HCM Lane LOS	A	A	-	-	A	-
HCM 95th %tile Q(veh)	-	-	-	-	0	-

HCM 6th Signalized Intersection Summary  
 10: US 101 NB Off Ramp/Lakewood Drive & Old Redwood Highway

General Plan 2040 Conditions  
 Timing Plan: P.M. Peak



Movement	EBL	EBT	EBR	WBL	WBT	WBR	NBL	NBT	NBR	SBL	SBT	SBR
Lane Configurations	↔↔	↑			↑↑		↔	↔↔		↔↔		↔
Traffic Volume (veh/h)	309	672	0	0	715	270	528	539	303	386	0	618
Future Volume (veh/h)	309	672	0	0	715	270	528	539	303	386	0	618
Initial Q (Qb), veh	0	0	0	0	0	0	0	0	0	0	0	0
Ped-Bike Adj(A_pbT)	1.00		1.00	1.00		0.98	1.00		0.99	1.00		1.00
Parking Bus, Adj	1.00	1.00	1.00	1.00	1.00	1.00	1.00	1.00	1.00	1.00	1.00	1.00
Work Zone On Approach		No			No			No			No	
Adj Sat Flow, veh/h/ln	1870	1870	0	0	1870	1870	1870	1870	1870	1870	0	1870
Adj Flow Rate, veh/h	355	772	0	0	786	297	496	695	329	402	0	0
Peak Hour Factor	0.87	0.87	0.87	0.91	0.91	0.91	0.92	0.92	0.92	0.96	0.96	0.96
Percent Heavy Veh, %	2	2	0	0	2	2	2	2	2	2	0	2
Cap, veh/h	404	978	0	0	887	335	623	838	396	0	0	0
Arrive On Green	0.12	0.52	0.00	0.00	0.35	0.35	0.35	0.35	0.35	0.00	0.00	0.00
Sat Flow, veh/h	3456	1870	0	0	2601	947	1781	2394	1133		0	
Grp Volume(v), veh/h	355	772	0	0	557	526	496	543	481		0.0	
Grp Sat Flow(s),veh/h/ln	1728	1870	0	0	1777	1677	1781	1870	1657			
Q Serve(g_s), s	7.8	25.8	0.0	0.0	22.7	22.7	19.3	20.4	20.5			
Cycle Q Clear(g_c), s	7.8	25.8	0.0	0.0	22.7	22.7	19.3	20.4	20.5			
Prop In Lane	1.00		0.00	0.00		0.56	1.00		0.68			
Lane Grp Cap(c), veh/h	404	978	0	0	628	593	623	654	580			
V/C Ratio(X)	0.88	0.79	0.00	0.00	0.89	0.89	0.80	0.83	0.83			
Avail Cap(c_a), veh/h	404	978	0	0	628	593	672	705	625			
HCM Platoon Ratio	1.00	1.00	1.00	1.00	1.00	1.00	1.00	1.00	1.00			
Upstream Filter(I)	1.00	1.00	0.00	0.00	1.00	1.00	1.00	1.00	1.00			
Uniform Delay (d), s/veh	33.4	14.9	0.0	0.0	23.4	23.4	22.5	22.9	22.9			
Incr Delay (d2), s/veh	19.2	6.5	0.0	0.0	16.8	17.7	6.2	7.8	8.7			
Initial Q Delay(d3),s/veh	0.0	0.0	0.0	0.0	0.0	0.0	0.0	0.0	0.0			
%ile BackOfQ(50%),veh/ln	4.2	11.1	0.0	0.0	11.6	11.1	8.6	9.8	8.9			
Unsig. Movement Delay, s/veh												
LnGrp Delay(d),s/veh	52.6	21.4	0.0	0.0	40.2	41.1	28.8	30.7	31.6			
LnGrp LOS	D	C	A	A	D	D	C	C	C			
Approach Vol, veh/h		1127			1083			1520				
Approach Delay, s/veh		31.2			40.6			30.3				
Approach LOS		C			D			C				
Timer - Assigned Phs		2			5	6		8				
Phs Duration (G+Y+Rc), s		45.3			13.0	32.3		31.6				
Change Period (Y+Rc), s		5.1			4.0	5.1		4.7				
Max Green Setting (Gmax), s		40.2			9.0	27.2		29.0				
Max Q Clear Time (g_c+I1), s		27.8			9.8	24.7		22.5				
Green Ext Time (p_c), s		4.3			0.0	1.6		4.3				

Intersection Summary

HCM 6th Ctrl Delay	33.6
HCM 6th LOS	C

Notes

User approved volume balancing among the lanes for turning movement.  
 Unsignalized Delay for [SBR] is excluded from calculations of the approach delay and intersection delay.

HCM 6th Signalized Intersection Summary

General Plan 2040 Conditions

12: US 101 SB On Ramp/US 101 SB Off Ramp & Old Redwood Highway























Timing Plan: P.M. Peak



Movement	EBL	EBT	EBR	WBL	WBT	WBR	NBL	NBT	NBR	SBL	SBT	SBR
Lane Configurations		↑↑	↗	↘	↑↑					↘	↕	
Traffic Volume (veh/h)	0	612	501	443	1121	0	0	0	0	301	2	221
Future Volume (veh/h)	0	612	501	443	1121	0	0	0	0	301	2	221
Initial Q (Qb), veh	0	0	0	0	0	0				0	0	0
Ped-Bike Adj(A_pbT)	1.00		0.98	1.00		1.00				1.00		1.00
Parking Bus, Adj	1.00	1.00	1.00	1.00	1.00	1.00				1.00	1.00	1.00
Work Zone On Approach		No			No						No	
Adj Sat Flow, veh/h/ln	0	1870	1870	1870	1870	0				1870	1870	1870
Adj Flow Rate, veh/h	0	651	533	498	1260	0				316	68	0
Peak Hour Factor	0.94	0.94	0.94	0.89	0.89	0.89				0.83	0.83	0.83
Percent Heavy Veh, %	0	2	2	2	2	0				2	2	2
Cap, veh/h	0	1416	622	458	2533	0				262	275	
Arrive On Green	0.00	0.40	0.40	0.26	0.71	0.00				0.15	0.15	0.00
Sat Flow, veh/h	0	3647	1560	1781	3647	0				1781	1870	0
Grp Volume(v), veh/h	0	651	533	498	1260	0				316	68	0
Grp Sat Flow(s),veh/h/ln	0	1777	1560	1781	1777	0				1781	1870	0
Q Serve(g_s), s	0.0	9.4	21.8	18.0	11.0	0.0				10.3	2.3	0.0
Cycle Q Clear(g_c), s	0.0	9.4	21.8	18.0	11.0	0.0				10.3	2.3	0.0
Prop In Lane	0.00		1.00	1.00		0.00				1.00		0.00
Lane Grp Cap(c), veh/h	0	1416	622	458	2533	0				262	275	
V/C Ratio(X)	0.00	0.46	0.86	1.09	0.50	0.00				1.21	0.25	
Avail Cap(c_a), veh/h	0	1416	622	458	2533	0				262	275	
HCM Platoon Ratio	1.00	1.00	1.00	1.00	1.00	1.00				1.00	1.00	1.00
Upstream Filter(I)	0.00	1.00	1.00	1.00	1.00	0.00				1.00	1.00	0.00
Uniform Delay (d), s/veh	0.0	15.5	19.2	26.0	4.5	0.0				29.8	26.4	0.0
Incr Delay (d2), s/veh	0.0	1.1	14.2	67.7	0.7	0.0				122.9	0.5	0.0
Initial Q Delay(d3),s/veh	0.0	0.0	0.0	0.0	0.0	0.0				0.0	0.0	0.0
%ile BackOfQ(50%),veh/ln	0.0	3.6	9.4	15.6	2.6	0.0				13.2	1.0	0.0
Unsig. Movement Delay, s/veh												
LnGrp Delay(d),s/veh	0.0	16.6	33.5	93.7	5.2	0.0				152.7	26.9	0.0
LnGrp LOS	A	B	C	F	A	A				F	C	
Approach Vol, veh/h		1184			1758						384	
Approach Delay, s/veh		24.2			30.2						130.4	
Approach LOS		C			C						F	
Timer - Assigned Phs		2			5	6		8				
Phs Duration (G+Y+Rc), s		55.0			22.0	33.0		15.0				
Change Period (Y+Rc), s		5.1			4.0	5.1		4.7				
Max Green Setting (Gmax), s		49.9			18.0	27.9		10.3				
Max Q Clear Time (g_c+I1), s		13.0			20.0	23.8		12.3				
Green Ext Time (p_c), s		11.9			0.0	2.3		0.0				
<b>Intersection Summary</b>												
HCM 6th Ctrl Delay			39.6									
HCM 6th LOS			D									
<b>Notes</b>												
User approved volume balancing among the lanes for turning movement.												
User approved ignoring U-Turning movement.												
Unsignalized Delay for [SBR] is excluded from calculations of the approach delay and intersection delay.												

























HCM 6th Signalized Intersection Summary  
1: Old Redwood Hwy & Shiloh Road

General Plan 2040 Conditions  
Timing Plan: Saturday Midday Peak

												
Movement	EBL	EBT	EBR	WBL	WBT	WBR	NBL	NBT	NBR	SBL	SBT	SBR
Lane Configurations												
Traffic Volume (veh/h)	182	105	216	31	105	22	221	338	35	30	272	266
Future Volume (veh/h)	182	105	216	31	105	22	221	338	35	30	272	266
Initial Q (Qb), veh	0	0	0	0	0	0	0	0	0	0	0	0
Ped-Bike Adj(A_pbT)	1.00		0.97	1.00		1.00	1.00		0.98	1.00		0.97
Parking Bus, Adj	1.00	1.00	1.00	1.00	1.00	1.00	1.00	1.00	1.00	1.00	1.00	1.00
Work Zone On Approach		No			No			No			No	
Adj Sat Flow, veh/h/ln	1870	1870	1870	1870	1870	1870	1870	1870	1870	1870	1870	1870
Adj Flow Rate, veh/h	204	118	243	36	122	26	238	363	38	33	299	292
Peak Hour Factor	0.89	0.89	0.89	0.86	0.86	0.86	0.93	0.93	0.93	0.91	0.91	0.91
Percent Heavy Veh, %	2	2	2	2	2	2	2	2	2	2	2	2
Cap, veh/h	382	401	330	51	173	192	288	623	516	131	458	377
Arrive On Green	0.21	0.21	0.21	0.12	0.12	0.12	0.16	0.33	0.33	0.07	0.24	0.24
Sat Flow, veh/h	1781	1870	1536	421	1428	1585	1781	1870	1552	1781	1870	1541
Grp Volume(v), veh/h	204	118	243	158	0	26	238	363	38	33	299	292
Grp Sat Flow(s),veh/h/ln	1781	1870	1536	1849	0	1585	1781	1870	1552	1781	1870	1541
Q Serve(g_s), s	6.9	3.6	10.0	5.6	0.0	1.0	8.8	10.9	1.1	1.2	9.7	12.0
Cycle Q Clear(g_c), s	6.9	3.6	10.0	5.6	0.0	1.0	8.8	10.9	1.1	1.2	9.7	12.0
Prop In Lane	1.00		1.00	0.23		1.00	1.00		1.00	1.00		1.00
Lane Grp Cap(c), veh/h	382	401	330	224	0	192	288	623	516	131	458	377
V/C Ratio(X)	0.53	0.29	0.74	0.71	0.00	0.14	0.83	0.58	0.07	0.25	0.65	0.77
Avail Cap(c_a), veh/h	801	841	691	1036	0	888	368	1199	995	144	965	795
HCM Platoon Ratio	1.00	1.00	1.00	1.00	1.00	1.00	1.00	1.00	1.00	1.00	1.00	1.00
Upstream Filter(I)	1.00	1.00	1.00	1.00	0.00	1.00	1.00	1.00	1.00	1.00	1.00	1.00
Uniform Delay (d), s/veh	23.6	22.3	24.9	28.7	0.0	26.6	27.5	18.7	15.5	29.7	23.0	23.9
Incr Delay (d2), s/veh	1.2	0.4	3.2	4.1	0.0	0.3	11.6	0.9	0.1	1.0	1.6	3.4
Initial Q Delay(d3),s/veh	0.0	0.0	0.0	0.0	0.0	0.0	0.0	0.0	0.0	0.0	0.0	0.0
%ile BackOfQ(50%),veh/ln	2.8	1.5	3.5	2.5	0.0	0.4	4.3	4.2	0.4	0.5	4.1	4.3
Unsig. Movement Delay, s/veh												
LnGrp Delay(d),s/veh	24.8	22.7	28.1	32.7	0.0	27.0	39.1	19.6	15.5	30.6	24.6	27.3
LnGrp LOS	C	C	C	C	A	C	D	B	B	C	C	C
Approach Vol, veh/h		565			184			639			624	
Approach Delay, s/veh		25.8			31.9			26.6			26.2	
Approach LOS		C			C			C			C	
Timer - Assigned Phs		2	3	4		6	7	8				
Phs Duration (G+Y+Rc), s		19.1	15.0	21.1		12.7	9.0	27.1				
Change Period (Y+Rc), s		4.5	4.0	4.5		4.5	4.0	4.5				
Max Green Setting (Gmax), s		30.5	14.0	35.0		38.0	5.5	43.5				
Max Q Clear Time (g_c+I1), s		12.0	10.8	14.0		7.6	3.2	12.9				
Green Ext Time (p_c), s		1.9	0.2	2.6		0.9	0.0	2.2				
<b>Intersection Summary</b>												
HCM 6th Ctrl Delay			26.7									
HCM 6th LOS			C									

HCM 6th Signalized Intersection Summary  
2: Shiloh Road & Hembree Ln

General Plan 2040 Conditions  
Timing Plan: Saturday Midday Peak

												
Movement	EBL	EBT	EBR	WBL	WBT	WBR	NBL	NBT	NBR	SBL	SBT	SBR
Lane Configurations	 			 	 						 	
Traffic Volume (veh/h)	918	372	69	110	298	235	111	21	128	236	11	856
Future Volume (veh/h)	918	372	69	110	298	235	111	21	128	236	11	856
Initial Q (Qb), veh	0	0	0	0	0	0	0	0	0	0	0	0
Ped-Bike Adj(A_pbT)	1.00		1.00	1.00		1.00	1.00		1.00	1.00		1.00
Parking Bus, Adj	1.00	1.00	1.00	1.00	1.00	1.00	1.00	1.00	1.00	1.00	1.00	1.00
Work Zone On Approach		No			No			No			No	
Adj Sat Flow, veh/h/ln	1870	1870	1870	1870	1870	1870	1870	1870	1870	1870	1870	1870
Adj Flow Rate, veh/h	977	396	69	110	310	245	111	21	128	259	11	941
Peak Hour Factor	0.94	0.94	1.00	1.00	0.96	0.96	1.00	1.00	1.00	0.91	1.00	0.91
Percent Heavy Veh, %	2	2	2	2	2	2	2	2	2	2	2	2
Cap, veh/h	917	666	116	140	464	358	153	20	119	267	11	668
Arrive On Green	0.27	0.43	0.43	0.08	0.24	0.24	0.09	0.09	0.09	0.16	0.16	0.16
Sat Flow, veh/h	3456	1551	270	1781	1909	1471	1781	228	1392	1712	73	1585
Grp Volume(v), veh/h	977	0	465	110	288	267	111	0	149	270	0	941
Grp Sat Flow(s),veh/h/ln	1728	0	1821	1781	1777	1603	1781	0	1620	1785	0	1585
Q Serve(g_s), s	17.0	0.0	12.5	3.9	9.4	9.7	3.9	0.0	5.5	9.6	0.0	10.0
Cycle Q Clear(g_c), s	17.0	0.0	12.5	3.9	9.4	9.7	3.9	0.0	5.5	9.6	0.0	10.0
Prop In Lane	1.00		0.15	1.00		0.92	1.00		0.86	0.96		1.00
Lane Grp Cap(c), veh/h	917	0	782	140	432	390	153	0	139	279	0	668
V/C Ratio(X)	1.07	0.00	0.59	0.78	0.67	0.68	0.73	0.00	1.07	0.97	0.00	1.41
Avail Cap(c_a), veh/h	917	0	1506	153	1151	1038	153	0	139	279	0	668
HCM Platoon Ratio	1.00	1.00	1.00	1.00	1.00	1.00	1.00	1.00	1.00	1.00	1.00	1.00
Upstream Filter(I)	1.00	0.00	1.00	1.00	1.00	1.00	1.00	0.00	1.00	1.00	0.00	1.00
Uniform Delay (d), s/veh	23.5	0.0	14.0	29.0	21.9	22.0	28.6	0.0	29.3	26.9	0.0	18.5
Incr Delay (d2), s/veh	48.9	0.0	0.7	21.3	1.8	2.1	15.8	0.0	96.8	45.4	0.0	192.9
Initial Q Delay(d3),s/veh	0.0	0.0	0.0	0.0	0.0	0.0	0.0	0.0	0.0	0.0	0.0	0.0
%ile BackOfQ(50%),veh/ln	12.3	0.0	4.4	2.4	3.7	3.5	2.3	0.0	5.8	7.3	0.0	44.3
Unsig. Movement Delay, s/veh												
LnGrp Delay(d),s/veh	72.4	0.0	14.7	50.2	23.7	24.2	44.3	0.0	126.1	72.3	0.0	211.5
LnGrp LOS	F	A	B	D	C	C	D	A	F	E	A	F
Approach Vol, veh/h		1442			665			260			1211	
Approach Delay, s/veh		53.8			28.3			91.2			180.4	
Approach LOS		D			C			F			F	
Timer - Assigned Phs	1	2		4	5	6		8				
Phs Duration (G+Y+Rc), s	9.1	31.5		14.0	21.0	19.6		9.5				
Change Period (Y+Rc), s	4.0	4.0		4.0	4.0	4.0		4.0				
Max Green Setting (Gmax), s	5.5	53.0		10.0	17.0	41.5		5.5				
Max Q Clear Time (g_c+I1), s	5.9	14.5		12.0	19.0	11.7		7.5				
Green Ext Time (p_c), s	0.0	3.0		0.0	0.0	3.5		0.0				
<b>Intersection Summary</b>												
HCM 6th Ctrl Delay				94.6								
HCM 6th LOS				F								

HCM 6th Signalized Intersection Summary  
 3: US 101 NB Off-Ramp & Shiloh Road

General Plan 2040 Conditions  
 Timing Plan: Saturday Midday Peak



Movement	EBT	EBR	WBL	WBT	NBL	NBR
Lane Configurations	↑↑			↑	↵	↵↵
Traffic Volume (veh/h)	523	0	0	901	520	765
Future Volume (veh/h)	523	0	0	901	520	765
Initial Q (Qb), veh	0	0	0	0	0	0
Ped-Bike Adj(A_pbT)		1.00	1.00		1.00	1.00
Parking Bus, Adj	1.00	1.00	1.00	1.00	1.00	1.00
Work Zone On Approach	No			No	No	
Adj Sat Flow, veh/h/ln	1870	0	0	1870	1870	1870
Adj Flow Rate, veh/h	575	0	0	1012	547	805
Peak Hour Factor	0.91	0.91	0.89	0.89	0.95	0.95
Percent Heavy Veh, %	2	0	0	2	2	2
Cap, veh/h	1748	0	0	920	662	1037
Arrive On Green	0.49	0.00	0.00	0.49	0.37	0.37
Sat Flow, veh/h	3741	0	0	1870	1781	2790
Grp Volume(v), veh/h	575	0	0	1012	547	805
Grp Sat Flow(s),veh/h/ln	1777	0	0	1870	1781	1395
Q Serve(g_s), s	6.5	0.0	0.0	32.5	18.4	16.8
Cycle Q Clear(g_c), s	6.5	0.0	0.0	32.5	18.4	16.8
Prop In Lane		0.00	0.00		1.00	1.00
Lane Grp Cap(c), veh/h	1748	0	0	920	662	1037
V/C Ratio(X)	0.33	0.00	0.00	1.10	0.83	0.78
Avail Cap(c_a), veh/h	1748	0	0	920	822	1288
HCM Platoon Ratio	1.00	1.00	1.00	1.00	1.00	1.00
Upstream Filter(I)	1.00	0.00	0.00	1.00	1.00	1.00
Uniform Delay (d), s/veh	10.2	0.0	0.0	16.8	18.8	18.3
Incr Delay (d2), s/veh	0.1	0.0	0.0	60.9	5.7	2.4
Initial Q Delay(d3),s/veh	0.0	0.0	0.0	0.0	0.0	0.0
%ile BackOfQ(50%),veh/ln	2.1	0.0	0.0	26.4	7.9	5.2
Unsig. Movement Delay, s/veh						
LnGrp Delay(d),s/veh	10.3	0.0	0.0	77.7	24.5	20.7
LnGrp LOS	B	A	A	F	C	C
Approach Vol, veh/h	575			1012	1352	
Approach Delay, s/veh	10.3			77.7	22.3	
Approach LOS	B			E	C	
Timer - Assigned Phs		2			6	8
Phs Duration (G+Y+Rc), s		37.0			37.0	29.1
Change Period (Y+Rc), s		4.5			4.5	4.5
Max Green Setting (Gmax), s		32.5			32.5	30.5
Max Q Clear Time (g_c+I1), s		8.5			34.5	20.4
Green Ext Time (p_c), s		3.7			0.0	4.2
<b>Intersection Summary</b>						
HCM 6th Ctrl Delay			39.0			
HCM 6th LOS			D			

HCM Signalized Intersection Capacity Analysis  
4: Shiloh Road & US 101 SB Off-Ramp

General Plan 2040 Conditions  
Timing Plan: Saturday Midday Peak



Movement	EBL	EBT	WBT	WBR	SBL	SBR
Lane Configurations		↑	↑		↙	↗
Traffic Volume (vph)	0	391	760	0	248	223
Future Volume (vph)	0	391	760	0	248	223
Ideal Flow (vphp)	1900	1900	1900	1900	1900	1900
Total Lost time (s)		4.5	4.5		4.5	4.5
Lane Util. Factor		1.00	1.00		1.00	1.00
Frbp, ped/bikes		1.00	1.00		1.00	1.00
Flpb, ped/bikes		1.00	1.00		1.00	1.00
Frt		1.00	1.00		1.00	0.85
Flt Protected		1.00	1.00		0.95	1.00
Satd. Flow (prot)		1863	1863		1770	1583
Flt Permitted		1.00	1.00		0.95	1.00
Satd. Flow (perm)		1863	1863		1770	1583
Peak-hour factor, PHF	0.96	0.96	0.96	0.96	0.68	0.68
Adj. Flow (vph)	0	407	792	0	365	328
RTOR Reduction (vph)	0	0	0	0	0	179
Lane Group Flow (vph)	0	407	792	0	365	149
Confl. Bikes (#/hr)				2		
Turn Type		NA	NA		Perm	Perm
Protected Phases		2	6			
Permitted Phases					4	4
Actuated Green, G (s)		28.8	28.8		16.9	16.9
Effective Green, g (s)		28.8	28.8		16.9	16.9
Actuated g/C Ratio		0.53	0.53		0.31	0.31
Clearance Time (s)		4.5	4.5		4.5	4.5
Vehicle Extension (s)		3.0	3.0		3.0	3.0
Lane Grp Cap (vph)		980	980		546	489
v/s Ratio Prot		0.22	c0.43			
v/s Ratio Perm					c0.21	0.09
v/c Ratio		0.42	0.81		0.67	0.30
Uniform Delay, d1		7.8	10.7		16.5	14.4
Progression Factor		1.00	1.00		1.00	1.00
Incremental Delay, d2		0.3	5.0		3.1	0.4
Delay (s)		8.1	15.6		19.6	14.8
Level of Service		A	B		B	B
Approach Delay (s)		8.1	15.6		17.3	
Approach LOS		A	B		B	
<b>Intersection Summary</b>						
HCM 2000 Control Delay			14.6		HCM 2000 Level of Service	B
HCM 2000 Volume to Capacity ratio			0.76			
Actuated Cycle Length (s)			54.7		Sum of lost time (s)	9.0
Intersection Capacity Utilization			124.8%		ICU Level of Service	H
Analysis Period (min)			15			
c Critical Lane Group						



Intersection						
Int Delay, s/veh	5					
Movement	EBT	EBR	WBL	WBT	NBL	NBR
Lane Configurations	↑↑		↘	↑	↘	↘
Traffic Vol, veh/h	793	30	120	877	24	115
Future Vol, veh/h	793	30	120	877	24	115
Conflicting Peds, #/hr	0	0	0	0	1	0
Sign Control	Free	Free	Free	Free	Stop	Stop
RT Channelized	-	None	-	None	-	None
Storage Length	-	-	68	-	0	0
Veh in Median Storage, #	0	-	-	0	0	-
Grade, %	0	-	-	0	0	-
Peak Hour Factor	92	92	87	87	78	78
Heavy Vehicles, %	2	2	2	2	2	2
Mvmt Flow	862	33	138	1008	31	147



















Major/Minor	Major1	Major2	Minor1		
Conflicting Flow All	0	0	895	0	2164 448
Stage 1	-	-	-	-	879 -
Stage 2	-	-	-	-	1285 -
Critical Hdwy	-	-	4.13	-	6.63 6.93
Critical Hdwy Stg 1	-	-	-	-	5.83 -
Critical Hdwy Stg 2	-	-	-	-	5.43 -
Follow-up Hdwy	-	-	2.219	-	3.519 3.319
Pot Cap-1 Maneuver	-	-	756	-	46 559
Stage 1	-	-	-	-	367 -
Stage 2	-	-	-	-	259 -
Platoon blocked, %	-	-	-	-	-
Mov Cap-1 Maneuver	-	-	756	-	38 559
Mov Cap-2 Maneuver	-	-	-	-	38 -
Stage 1	-	-	-	-	367 -
Stage 2	-	-	-	-	211 -

Approach	EB	WB	NB
HCM Control Delay, s	0	1.3	54.1
HCM LOS			F

Minor Lane/Major Mvmt	NBLn1	NBLn2	EBT	EBR	WBL	WBT
Capacity (veh/h)	38	559	-	-	756	-
HCM Lane V/C Ratio	0.81	0.264	-	-	0.182	-
HCM Control Delay (s)	247.6	13.7	-	-	10.8	-
HCM Lane LOS	F	B	-	-	B	-
HCM 95th %tile Q(veh)	3	1.1	-	-	0.7	-

HCM Signalized Intersection Capacity Analysis  
6: Conde Lane & Shiloh Road

General Plan 2040 Conditions  
Timing Plan: Saturday Midday Peak

													
Movement	EBL	EBT	EBR	WBL	WBT	WBR	NBL	NBT	NBR	SBL	SBT	SBR	
Lane Configurations													
Traffic Volume (vph)	43	521	1	13	580	301	1	0	9	291	0	41	
Future Volume (vph)	43	521	1	13	580	301	1	0	9	291	0	41	
Ideal Flow (vphp)	1900	1900	1900	1900	1900	1900	1900	1900	1900	1900	1900	1900	
Total Lost time (s)	4.5	4.5		4.5	4.5			4.5			4.5	4.5	
Lane Util. Factor	1.00	0.95		1.00	0.95			1.00			1.00	1.00	
Frbp, ped/bikes	1.00	1.00		1.00	0.99			1.00			1.00	1.00	
Flpb, ped/bikes	1.00	1.00		1.00	1.00			1.00			1.00	1.00	
Frt	1.00	1.00		1.00	0.95			0.88			1.00	0.85	
Flt Protected	0.95	1.00		0.95	1.00			0.99			0.95	1.00	
Satd. Flow (prot)	1770	3538		1770	3333			1630			1770	1583	
Flt Permitted	0.95	1.00		0.95	1.00			0.99			0.95	1.00	
Satd. Flow (perm)	1770	3538		1770	3333			1630			1770	1583	
Peak-hour factor, PHF	0.96	0.96	0.96	0.91	0.91	0.91	0.58	0.58	0.58	0.78	0.78	0.78	
Adj. Flow (vph)	45	543	1	14	637	331	2	0	16	373	0	53	
RTOR Reduction (vph)	0	0	0	0	56	0	0	17	0	0	0	0	
Lane Group Flow (vph)	45	544	0	14	912	0	0	1	0	0	373	53	
Confl. Bikes (#/hr)						2							
Turn Type	Prot	NA		Prot	NA		Split	NA		Split	NA	custom	
Protected Phases	5	2		1	6		7	7		4	4		
Permitted Phases												6	
Actuated Green, G (s)	4.1	29.4		1.1	26.4			2.9			12.6	26.4	
Effective Green, g (s)	4.1	29.4		1.1	26.4			2.9			12.6	26.4	
Actuated g/C Ratio	0.06	0.46		0.02	0.41			0.05			0.20	0.41	
Clearance Time (s)	4.5	4.5		4.5	4.5			4.5			4.5	4.5	
Vehicle Extension (s)	3.0	3.0		3.0	3.0			3.0			3.0	3.0	
Lane Grp Cap (vph)	113	1625		30	1374			73			348	652	
v/s Ratio Prot	c0.03	c0.15		0.01	c0.27			c0.00			c0.21		
v/s Ratio Perm												0.03	
v/c Ratio	0.40	0.33		0.47	0.66			0.01			1.07	0.08	
Uniform Delay, d1	28.8	11.1		31.2	15.2			29.2			25.7	11.4	
Progression Factor	1.00	1.00		1.00	1.00			1.00			1.00	1.00	
Incremental Delay, d2	2.3	0.1		11.0	1.2			0.1			68.7	0.1	
Delay (s)	31.1	11.2		42.2	16.4			29.2			94.4	11.5	
Level of Service	C	B		D	B			C			F	B	
Approach Delay (s)		12.7			16.8			29.2			84.1		
Approach LOS		B			B			C			F		
<b>Intersection Summary</b>													
HCM 2000 Control Delay			29.9									HCM 2000 Level of Service	C
HCM 2000 Volume to Capacity ratio			0.71										
Actuated Cycle Length (s)			64.0									Sum of lost time (s)	18.0
Intersection Capacity Utilization			66.0%									ICU Level of Service	C
Analysis Period (min)			15										
c Critical Lane Group													

HCM 6th TWSC  
7: Entrance 1/Gridley Drive & Shiloh Road

General Plan 2040 Conditions  
Timing Plan: Saturday Midday Peak

Intersection												
Int Delay, s/veh	1.7											
Movement	EBL	EBT	EBR	WBL	WBT	WBR	NBL	NBT	NBR	SBL	SBT	SBR
Lane Configurations		↕			↕		↕	↕			↕	
Traffic Vol, veh/h	30	157	0	0	136	0	0	0	0	0	0	27
Future Vol, veh/h	30	157	0	0	136	0	0	0	0	0	0	27
Conflicting Peds, #/hr	1	0	0	0	0	0	0	0	0	0	0	0
Sign Control	Free	Free	Free	Free	Free	Free	Stop	Stop	Stop	Stop	Stop	Stop
RT Channelized	-	-	None	-	-	None	-	-	None	-	-	None
Storage Length	-	-	-	-	-	-	0	-	-	-	-	-
Veh in Median Storage, #	-	0	-	-	0	-	-	0	-	-	0	-
Grade, %	-	0	-	-	0	-	-	0	-	-	0	-
Peak Hour Factor	93	93	93	88	88	88	100	100	100	56	56	56
Heavy Vehicles, %	2	2	2	2	2	2	2	2	2	2	2	2
Mvmt Flow	32	169	0	0	155	0	0	0	0	0	0	48

Major/Minor	Major1			Major2			Minor1			Minor2		
Conflicting Flow All	156	0	0	169	0	0	412	389	169	389	389	156
Stage 1	-	-	-	-	-	-	233	233	-	156	156	-
Stage 2	-	-	-	-	-	-	179	156	-	233	233	-
Critical Hdwy	4.12	-	-	4.12	-	-	7.12	6.52	6.22	7.12	6.52	6.22
Critical Hdwy Stg 1	-	-	-	-	-	-	6.12	5.52	-	6.12	5.52	-
Critical Hdwy Stg 2	-	-	-	-	-	-	6.12	5.52	-	6.12	5.52	-
Follow-up Hdwy	2.218	-	-	2.218	-	-	3.518	4.018	3.318	3.518	4.018	3.318
Pot Cap-1 Maneuver	1424	-	-	1409	-	-	550	546	875	570	546	890
Stage 1	-	-	-	-	-	-	770	712	-	846	769	-
Stage 2	-	-	-	-	-	-	823	769	-	770	712	-
Platoon blocked, %		-	-		-	-						
Mov Cap-1 Maneuver	1423	-	-	1409	-	-	510	532	875	559	532	889
Mov Cap-2 Maneuver	-	-	-	-	-	-	510	532	-	559	532	-
Stage 1	-	-	-	-	-	-	751	694	-	824	768	-
Stage 2	-	-	-	-	-	-	778	768	-	751	694	-

Approach	EB	WB	NB	SB
HCM Control Delay, s	1.2	0	0	9.3
HCM LOS			A	A

Minor Lane/Major Mvmt	NBLn1	NBLn2	EBL	EBT	EBR	WBL	WBT	WBR	SBLn1
Capacity (veh/h)	-	-	1423	-	-	1409	-	-	889
HCM Lane V/C Ratio	-	-	0.023	-	-	-	-	-	0.054
HCM Control Delay (s)	0	0	7.6	0	-	0	-	-	9.3
HCM Lane LOS	A	A	A	A	-	A	-	-	A
HCM 95th %tile Q(veh)	-	-	0.1	-	-	0	-	-	0.2

HCM 6th TWSC  
8: Old Redwood Hwy & Entrance 1

General Plan 2040 Conditions  
Timing Plan: Saturday Midday Peak

Intersection												
Int Delay, s/veh	0.1											
Movement	EBL	EBT	EBR	WBL	WBT	WBR	NBL	NBT	NBR	SBL	SBT	SBR
Lane Configurations		↕		↕	↕			↕		↕	↕	
Traffic Vol, veh/h	1	0	3	0	0	0	1	595	0	0	505	6
Future Vol, veh/h	1	0	3	0	0	0	1	595	0	0	505	6
Conflicting Peds, #/hr	0	0	0	0	0	0	1	0	4	4	0	1
Sign Control	Stop	Stop	Stop	Stop	Stop	Stop	Free	Free	Free	Free	Free	Free
RT Channelized	-	-	None	-	-	None	-	-	None	-	-	None
Storage Length	-	-	-	0	-	-	-	-	-	50	-	-
Veh in Median Storage, #	-	0	-	-	0	-	-	0	-	-	0	-
Grade, %	-	0	-	-	0	-	-	0	-	-	0	-
Peak Hour Factor	38	38	38	100	100	100	94	94	94	93	93	93
Heavy Vehicles, %	2	2	2	2	2	2	2	2	2	2	2	2
Mvmt Flow	3	0	8	0	0	0	1	633	0	0	543	6

Major/Minor	Minor2		Minor1		Major1		Major2					
Conflicting Flow All	1182	1186	547	1189	1189	637	550	0	0	637	0	0
Stage 1	547	547	-	639	639	-	-	-	-	-	-	-
Stage 2	635	639	-	550	550	-	-	-	-	-	-	-
Critical Hdwy	7.12	6.52	6.22	7.12	6.52	6.22	4.12	-	-	4.12	-	-
Critical Hdwy Stg 1	6.12	5.52	-	6.12	5.52	-	-	-	-	-	-	-
Critical Hdwy Stg 2	6.12	5.52	-	6.12	5.52	-	-	-	-	-	-	-
Follow-up Hdwy	3.518	4.018	3.318	3.518	4.018	3.318	2.218	-	-	2.218	-	-
Pot Cap-1 Maneuver	167	189	537	165	188	477	1020	-	-	947	-	-
Stage 1	521	517	-	464	470	-	-	-	-	-	-	-
Stage 2	467	470	-	519	516	-	-	-	-	-	-	-
Platoon blocked, %								-	-	-	-	-
Mov Cap-1 Maneuver	167	188	536	162	187	475	1019	-	-	943	-	-
Mov Cap-2 Maneuver	167	188	-	162	187	-	-	-	-	-	-	-
Stage 1	519	516	-	461	467	-	-	-	-	-	-	-
Stage 2	466	467	-	511	515	-	-	-	-	-	-	-

Approach	EB	WB	NB	SB
HCM Control Delay, s	15.8	0	0	0
HCM LOS	C	A		

Minor Lane/Major Mvmt	NBL	NBT	NBR	EBLn1	WBLn1	WBLn2	SBL	SBT	SBR
Capacity (veh/h)	1019	-	-	345	-	-	943	-	-
HCM Lane V/C Ratio	0.001	-	-	0.031	-	-	-	-	-
HCM Control Delay (s)	8.5	0	-	15.8	0	0	0	-	-
HCM Lane LOS	A	A	-	C	A	A	A	-	-
HCM 95th %tile Q(veh)	0	-	-	0.1	-	-	0	-	-

HCM 6th TWSC  
9: Entrance 2 & Shiloh Road

General Plan 2040 Conditions  
Timing Plan: Saturday Midday Peak

Intersection						
Int Delay, s/veh	0					
Movement	EBT	EBR	WBL	WBT	NBL	NBR
Lane Configurations						
Traffic Vol, veh/h	136	0	0	127	0	0
Future Vol, veh/h	136	0	0	127	0	0
Conflicting Peds, #/hr	0	1	0	0	0	0
Sign Control	Free	Free	Free	Free	Stop	Stop
RT Channelized	-	None	-	None	-	None
Storage Length	-	-	-	-	0	0
Veh in Median Storage, #	0	-	-	0	0	-
Grade, %	0	-	-	0	0	-
Peak Hour Factor	88	88	80	80	100	100
Heavy Vehicles, %	2	2	2	2	2	2
Mvmt Flow	155	0	0	159	0	0

Major/Minor	Major1	Major2	Minor1		
Conflicting Flow All	0	0	156	0	315
Stage 1	-	-	-	-	156
Stage 2	-	-	-	-	159
Critical Hdwy	-	-	4.12	-	6.42
Critical Hdwy Stg 1	-	-	-	-	5.42
Critical Hdwy Stg 2	-	-	-	-	5.42
Follow-up Hdwy	-	-	2.218	-	3.518
Pot Cap-1 Maneuver	-	-	1424	-	678
Stage 1	-	-	-	-	872
Stage 2	-	-	-	-	870
Platoon blocked, %	-	-	-	-	-
Mov Cap-1 Maneuver	-	-	1423	-	677
Mov Cap-2 Maneuver	-	-	-	-	677
Stage 1	-	-	-	-	871
Stage 2	-	-	-	-	870

Approach	EB	WB	NB
HCM Control Delay, s	0	0	0
HCM LOS			A

Minor Lane/Major Mvmt	NBLn1	NBLn2	EBT	EBR	WBL	WBT
Capacity (veh/h)	-	-	-	-	1423	-
HCM Lane V/C Ratio	-	-	-	-	-	-
HCM Control Delay (s)	0	0	-	-	0	-
HCM Lane LOS	A	A	-	-	A	-
HCM 95th %tile Q(veh)	-	-	-	-	0	-

HCM 6th Signalized Intersection Summary

General Plan 2040 Conditions

10: US 101 NB Off Ramp/Lakewood Drive & Old Redwood Highway Timing Plan: Saturday Midday Peak



Movement	EBL	EBT	EBR	WBL	WBT	WBR	NBL	NBT	NBR	SBL	SBT	SBR
Lane Configurations	↔↔	↑			↑↑		↔	↔↔		↔↔		↔
Traffic Volume (veh/h)	372	406	0	0	651	357	415	393	185	316	0	908
Future Volume (veh/h)	372	406	0	0	651	357	415	393	185	316	0	908
Initial Q (Qb), veh	0	0	0	0	0	0	0	0	0	0	0	0
Ped-Bike Adj(A_pbT)	1.00		1.00	1.00		0.98	1.00		1.00	1.00		1.00
Parking Bus, Adj	1.00	1.00	1.00	1.00	1.00	1.00	1.00	1.00	1.00	1.00	1.00	1.00
Work Zone On Approach		No			No			No			No	
Adj Sat Flow, veh/h/ln	1870	1870	0	0	1870	1870	1870	1870	1870	1870	0	1870
Adj Flow Rate, veh/h	392	427	0	0	731	401	338	520	189	359	0	0
Peak Hour Factor	0.95	0.95	0.95	0.89	0.89	0.89	0.98	0.98	0.98	0.88	0.88	0.88
Percent Heavy Veh, %	2	2	0	0	2	2	2	2	2	2	0	2
Cap, veh/h	374	1101	0	0	916	501	501	737	267	0	0	0
Arrive On Green	0.11	0.59	0.00	0.00	0.42	0.42	0.28	0.28	0.28	0.00	0.00	0.00
Sat Flow, veh/h	3456	1870	0	0	2297	1205	1781	2621	948		0	
Grp Volume(v), veh/h	392	427	0	0	589	543	338	370	339		0.0	
Grp Sat Flow(s),veh/h/ln	1728	1870	0	0	1777	1632	1781	1870	1699			
Q Serve(g_s), s	7.5	8.4	0.0	0.0	20.1	20.2	11.7	12.3	12.4			
Cycle Q Clear(g_c), s	7.5	8.4	0.0	0.0	20.1	20.2	11.7	12.3	12.4			
Prop In Lane	1.00		0.00	0.00		0.74	1.00		0.56			
Lane Grp Cap(c), veh/h	374	1101	0	0	738	678	501	526	478			
V/C Ratio(X)	1.05	0.39	0.00	0.00	0.80	0.80	0.67	0.70	0.71			
Avail Cap(c_a), veh/h	374	1101	0	0	738	678	751	788	716			
HCM Platoon Ratio	1.00	1.00	1.00	1.00	1.00	1.00	1.00	1.00	1.00			
Upstream Filter(I)	1.00	1.00	0.00	0.00	1.00	1.00	1.00	1.00	1.00			
Uniform Delay (d), s/veh	30.9	7.6	0.0	0.0	17.7	17.7	22.1	22.3	22.3			
Incr Delay (d2), s/veh	59.7	1.0	0.0	0.0	8.8	9.6	1.6	1.7	1.9			
Initial Q Delay(d3),s/veh	0.0	0.0	0.0	0.0	0.0	0.0	0.0	0.0	0.0			
%ile BackOfQ(50%),veh/ln	6.0	3.0	0.0	0.0	9.0	8.4	4.8	5.3	4.9			
Unsig. Movement Delay, s/veh												
LnGrp Delay(d),s/veh	90.6	8.6	0.0	0.0	26.5	27.4	23.7	24.0	24.3			
LnGrp LOS	F	A	A	A	C	C	C	C	C			
Approach Vol, veh/h		819			1132			1047				
Approach Delay, s/veh		47.9			26.9			24.0				
Approach LOS		D			C			C				
Timer - Assigned Phs		2			5	6		8				
Phs Duration (G+Y+Rc), s		45.3			12.0	33.3		24.0				
Change Period (Y+Rc), s		4.5			4.5	4.5		4.5				
Max Green Setting (Gmax), s		40.8			7.5	28.8		29.2				
Max Q Clear Time (g_c+I1), s		10.4			9.5	22.2		14.4				
Green Ext Time (p_c), s		2.7			0.0	3.8		5.0				

Intersection Summary

HCM 6th Ctrl Delay	31.6
HCM 6th LOS	C

Notes

User approved volume balancing among the lanes for turning movement.  
 Unsignalized Delay for [SBR] is excluded from calculations of the approach delay and intersection delay.

# HCM 6th Signalized Intersection Summary

General Plan 2040 Conditions

12: US 101 SB On Ramp/US 101 SB Off Ramp & Old Redwood Highway  
 Timing Plan: Saturday Midday Peak



Movement	EBL	EBT	EBR	WBL	WBT	WBR	NBL	NBT	NBR	SBL	SBT	SBR
Lane Configurations		↑↑	↗	↘	↑↑					↘	↕	
Traffic Volume (veh/h)	0	713	543	632	1060	0	0	0	0	196	1	112
Future Volume (veh/h)	0	713	543	632	1060	0	0	0	0	196	1	112
Initial Q (Qb), veh	0	0	0	0	0	0				0	0	0
Ped-Bike Adj(A_pbT)	1.00		0.98	1.00		1.00				1.00		1.00
Parking Bus, Adj	1.00	1.00	1.00	1.00	1.00	1.00				1.00	1.00	1.00
Work Zone On Approach		No			No						No	
Adj Sat Flow, veh/h/ln	0	1870	1870	1870	1870	0				1870	1870	1870
Adj Flow Rate, veh/h	0	735	560	658	1104	0				214	81	0
Peak Hour Factor	0.97	0.97	0.97	0.96	0.96	0.96				0.72	0.72	0.72
Percent Heavy Veh, %	0	2	2	2	2	0				2	2	2
Cap, veh/h	0	1413	618	471	2581	0				258	271	
Arrive On Green	0.00	0.40	0.40	0.26	0.73	0.00				0.14	0.14	0.00
Sat Flow, veh/h	0	3647	1555	1781	3647	0				1781	1870	0
Grp Volume(v), veh/h	0	735	560	658	1104	0				214	81	0
Grp Sat Flow(s),veh/h/ln	0	1777	1555	1781	1777	0				1781	1870	0
Q Serve(g_s), s	0.0	11.0	23.7	18.5	8.6	0.0				8.2	2.7	0.0
Cycle Q Clear(g_c), s	0.0	11.0	23.7	18.5	8.6	0.0				8.2	2.7	0.0
Prop In Lane	0.00		1.00	1.00		0.00				1.00		0.00
Lane Grp Cap(c), veh/h	0	1413	618	471	2581	0				258	271	
V/C Ratio(X)	0.00	0.52	0.91	1.40	0.43	0.00				0.83	0.30	
Avail Cap(c_a), veh/h	0	1413	618	471	2581	0				260	273	
HCM Platoon Ratio	1.00	1.00	1.00	1.00	1.00	1.00				1.00	1.00	1.00
Upstream Filter(I)	0.00	1.00	1.00	1.00	1.00	0.00				1.00	1.00	0.00
Uniform Delay (d), s/veh	0.0	16.0	19.8	25.7	3.8	0.0				29.1	26.7	0.0
Incr Delay (d2), s/veh	0.0	1.4	19.3	191.0	0.5	0.0				19.5	0.6	0.0
Initial Q Delay(d3),s/veh	0.0	0.0	0.0	0.0	0.0	0.0				0.0	0.0	0.0
%ile BackOfQ(50%),veh/ln	0.0	4.3	10.8	32.2	2.0	0.0				4.7	1.2	0.0
Unsig. Movement Delay, s/veh												
LnGrp Delay(d),s/veh	0.0	17.4	39.1	216.7	4.3	0.0				48.6	27.3	0.0
LnGrp LOS	A	B	D	F	A	A				D	C	
Approach Vol, veh/h		1295			1762						295	
Approach Delay, s/veh		26.8			83.6						42.7	
Approach LOS		C			F						D	
Timer - Assigned Phs		2			5	6		8				
Phs Duration (G+Y+Rc), s		55.3			23.0	32.3		14.6				
Change Period (Y+Rc), s		4.5			4.5	4.5		4.5				
Max Green Setting (Gmax), s		50.8			18.5	27.8		10.2				
Max Q Clear Time (g_c+I1), s		10.6			20.5	25.7		10.2				
Green Ext Time (p_c), s		10.0			0.0	1.4		0.0				
<b>Intersection Summary</b>												
HCM 6th Ctrl Delay			58.1									
HCM 6th LOS			E									
<b>Notes</b>												
User approved volume balancing among the lanes for turning movement.												
User approved ignoring U-Turning movement.												
Unsignalized Delay for [SBR] is excluded from calculations of the approach delay and intersection delay.												

Queues  
1: Old Redwood Hwy & Shiloh Road

General Plan 2040 Conditions  
Timing Plan: A.M. PEAK



Lane Group	EBL	EBT	EBR	WBT	WBR	NBL	NBT	NBR	SBL	SBT	SBR
Lane Group Flow (vph)	386	173	495	183	16	362	331	19	36	556	468
v/c Ratio	0.83	0.35	0.63	0.68	0.05	1.59	0.42	0.03	0.39	0.96	0.81
Control Delay	55.9	36.9	7.2	59.2	0.3	319.0	27.2	0.1	66.3	68.5	37.5
Queue Delay	0.0	0.0	0.0	0.0	0.0	0.0	0.0	0.0	0.0	0.0	0.0
Total Delay	55.9	36.9	7.2	59.2	0.3	319.0	27.2	0.1	66.3	68.5	37.5
Queue Length 50th (ft)	264	102	0	128	0	~378	179	0	26	399	226
Queue Length 95th (ft)	#361	157	42	201	0	#602	286	0	60	#614	#378
Internal Link Dist (ft)		1709		528			668			695	
Turn Bay Length (ft)	375		140		50	200		98	130		93
Base Capacity (vph)	479	504	789	620	603	228	785	711	94	579	579
Starvation Cap Reductn	0	0	0	0	0	0	0	0	0	0	0
Spillback Cap Reductn	0	0	0	0	0	0	0	0	0	0	0
Storage Cap Reductn	0	0	0	0	0	0	0	0	0	0	0
Reduced v/c Ratio	0.81	0.34	0.63	0.30	0.03	1.59	0.42	0.03	0.38	0.96	0.81

Intersection Summary

~ Volume exceeds capacity, queue is theoretically infinite.

Queue shown is maximum after two cycles.

# 95th percentile volume exceeds capacity, queue may be longer.

Queue shown is maximum after two cycles.



Queues  
2: Shiloh Road & Hembree Ln

General Plan 2040 Conditions  
Timing Plan: A.M. PEAK

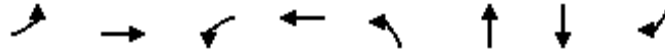

Lane Group	EBL	EBT	WBL	WBT	NBL	NBT	SBT	SBR
Lane Group Flow (vph)	353	909	49	834	49	27	155	606
v/c Ratio	0.44	0.80	0.37	0.60	0.37	0.19	0.63	0.83
Control Delay	30.4	19.5	47.3	19.1	47.3	28.3	49.1	29.6
Queue Delay	0.0	0.1	0.0	0.0	0.0	0.0	0.0	0.0
Total Delay	30.4	19.6	47.3	19.1	47.3	28.3	49.1	29.6
Queue Length 50th (ft)	88	383	26	165	26	6	82	185
Queue Length 95th (ft)	134	555	#65	219	#65	32	#189	#526
Internal Link Dist (ft)		222		1709		136	301	
Turn Bay Length (ft)			100					
Base Capacity (vph)	807	1346	134	2006	134	143	247	732
Starvation Cap Reductn	0	43	0	0	0	0	0	0
Spillback Cap Reductn	0	0	0	0	0	0	0	0
Storage Cap Reductn	0	0	0	0	0	0	0	0
Reduced v/c Ratio	0.44	0.70	0.37	0.42	0.37	0.19	0.63	0.83

Intersection Summary

# 95th percentile volume exceeds capacity, queue may be longer.  
Queue shown is maximum after two cycles.

Queues  
3: US 101 NB Off-Ramp & Shiloh Road

General Plan 2040 Conditions  
Timing Plan: A.M. PEAK

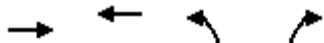

Lane Group	EBT	WBT	NBL	NBR
Lane Group Flow (vph)	712	1118	1070	626
v/c Ratio	0.44	1.31	1.40	0.47
Control Delay	14.3	170.5	212.4	9.7
Queue Delay	0.0	0.0	0.0	0.0
Total Delay	14.3	170.5	212.4	9.7
Queue Length 50th (ft)	107	~653	~651	60
Queue Length 95th (ft)	150	#878	#681	75
Internal Link Dist (ft)	106	291	689	
Turn Bay Length (ft)				265
Base Capacity (vph)	1622	853	762	1341
Starvation Cap Reductn	0	0	0	0
Spillback Cap Reductn	0	0	0	0
Storage Cap Reductn	0	0	0	0
Reduced v/c Ratio	0.44	1.31	1.40	0.47

Intersection Summary

- ~ Volume exceeds capacity, queue is theoretically infinite.  
Queue shown is maximum after two cycles.
- # 95th percentile volume exceeds capacity, queue may be longer.  
Queue shown is maximum after two cycles.

Queues

4: Shiloh Road & US 101 SB Off-Ramp

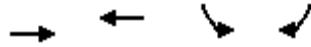

Lane Group	EBT	WBT	SBL	SBR
Lane Group Flow (vph)	439	1256	261	200
v/c Ratio	0.33	0.94	0.79	0.52
Control Delay	5.2	26.6	52.6	21.2
Queue Delay	0.0	0.0	0.0	0.0
Total Delay	5.2	26.6	52.6	21.2
Queue Length 50th (ft)	76	511	143	45
Queue Length 95th (ft)	114	#944	#262	112
Internal Link Dist (ft)	145	226	406	
Turn Bay Length (ft)				275
Base Capacity (vph)	1461	1461	372	418
Starvation Cap Reductn	0	0	0	0
Spillback Cap Reductn	0	0	0	0
Storage Cap Reductn	0	0	0	0
Reduced v/c Ratio	0.30	0.86	0.70	0.48

Intersection Summary

# 95th percentile volume exceeds capacity, queue may be longer.  
 Queue shown is maximum after two cycles.

Queues  
6: Conde Lane & Shiloh Road

General Plan 2040 Conditions  
Timing Plan: A.M. PEAK

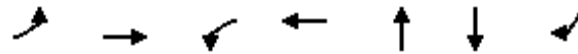

Lane Group	EBL	EBT	WBL	WBT	NBT	SBT	SBR
Lane Group Flow (vph)	58	551	9	1344	22	422	31
v/c Ratio	0.28	0.24	0.05	0.68	0.09	1.54	0.03
Control Delay	37.6	7.7	35.8	15.5	20.8	288.2	11.2
Queue Delay	0.0	0.0	0.0	0.0	0.0	0.0	0.0
Total Delay	37.6	7.7	35.8	15.5	20.8	288.2	11.2
Queue Length 50th (ft)	24	31	4	193	2	~271	6
Queue Length 95th (ft)	67	128	18	364	13	#505	22
Internal Link Dist (ft)		735		1001	338	442	
Turn Bay Length (ft)	90		127				40
Base Capacity (vph)	224	2299	199	1986	782	274	914
Starvation Cap Reductn	0	0	0	0	0	0	0
Spillback Cap Reductn	0	0	0	0	0	0	0
Storage Cap Reductn	0	0	0	0	0	0	0
Reduced v/c Ratio	0.26	0.24	0.05	0.68	0.03	1.54	0.03

Intersection Summary

~ Volume exceeds capacity, queue is theoretically infinite.

Queue shown is maximum after two cycles.

# 95th percentile volume exceeds capacity, queue may be longer.

Queue shown is maximum after two cycles.

Queues

10: US 101 NB Off Ramp/Lakewood Drive & Old Redwood Highway



Lane Group	EBL	EBT	WBT	NBL	NBT	SBL	SBR
Lane Group Flow (vph)	311	718	971	212	422	287	763
v/c Ratio	0.79	0.75	0.80	0.61	0.57	0.93	0.99
Control Delay	50.6	22.6	29.4	35.0	27.0	75.7	46.6
Queue Delay	0.0	0.0	0.0	0.0	0.0	0.0	0.0
Total Delay	50.6	22.6	29.4	35.0	27.0	75.7	46.6
Queue Length 50th (ft)	77	259	214	102	89	73	264
Queue Length 95th (ft)	#145	443	298	173	134	#163	#510
Internal Link Dist (ft)		146	537		636		
Turn Bay Length (ft)	155			270		120	
Base Capacity (vph)	396	961	1218	599	1236	308	773
Starvation Cap Reductn	0	0	0	0	0	0	0
Spillback Cap Reductn	0	0	0	0	0	0	0
Storage Cap Reductn	0	0	0	0	0	0	0
Reduced v/c Ratio	0.79	0.75	0.80	0.35	0.34	0.93	0.99

Intersection Summary

# 95th percentile volume exceeds capacity, queue may be longer.  
 Queue shown is maximum after two cycles.

Queues

12: US 101 SB On Ramp/US 101 SB Off Ramp & Old Redwood Highway



Lane Group	EBT	EBR	WBL	WBT	SBL	SBT
Lane Group Flow (vph)	760	885	628	834	175	197
v/c Ratio	0.63	1.15	0.98	0.31	0.83	0.57
Control Delay	25.1	101.9	58.5	3.6	67.4	14.4
Queue Delay	0.0	0.0	0.0	0.0	0.0	0.0
Total Delay	25.1	101.9	58.5	3.6	67.4	14.4
Queue Length 50th (ft)	165	~400	304	55	91	9
Queue Length 95th (ft)	224	#624	#511	73	#172	53
Internal Link Dist (ft)	343			451		751
Turn Bay Length (ft)			250		420	
Base Capacity (vph)	1203	767	641	2663	210	345
Starvation Cap Reductn	0	0	0	0	0	0
Spillback Cap Reductn	0	0	0	0	0	0
Storage Cap Reductn	0	0	0	0	0	0
Reduced v/c Ratio	0.63	1.15	0.98	0.31	0.83	0.57

Intersection Summary

~ Volume exceeds capacity, queue is theoretically infinite.

Queue shown is maximum after two cycles.

# 95th percentile volume exceeds capacity, queue may be longer.

Queue shown is maximum after two cycles.

Queues  
1: Old Redwood Hwy & Shiloh Road

General Plan 2040 Conditions  
Timing Plan: P.M. Peak



Lane Group	EBL	EBT	EBR	WBT	WBR	NBL	NBT	NBR	SBL	SBT	SBR
Lane Group Flow (vph)	327	129	590	201	34	643	599	47	46	576	285
v/c Ratio	0.77	0.29	0.73	0.70	0.10	2.77	0.78	0.07	0.48	0.98	0.51
Control Delay	52.9	36.9	10.1	58.1	0.6	829.2	39.4	2.1	71.5	71.0	24.2
Queue Delay	0.0	0.0	0.0	0.0	0.0	0.0	0.0	0.0	0.0	0.0	0.0
Total Delay	52.9	36.9	10.1	58.1	0.6	829.2	39.4	2.1	71.5	71.0	24.2
Queue Length 50th (ft)	218	75	15	142	0	~814	398	0	34	~432	107
Queue Length 95th (ft)	345	138	136	222	0	#1105	#656	10	#85	#723	209
Internal Link Dist (ft)		1709		528			668			695	
Turn Bay Length (ft)	375		140		50	200		98	130		93
Base Capacity (vph)	489	515	844	633	602	232	771	685	96	590	560
Starvation Cap Reductn	0	0	0	0	0	0	0	0	0	0	0
Spillback Cap Reductn	0	0	0	0	0	0	0	0	0	0	0
Storage Cap Reductn	0	0	0	0	0	0	0	0	0	0	0
Reduced v/c Ratio	0.67	0.25	0.70	0.32	0.06	2.77	0.78	0.07	0.48	0.98	0.51

Intersection Summary

~ Volume exceeds capacity, queue is theoretically infinite.

Queue shown is maximum after two cycles.

# 95th percentile volume exceeds capacity, queue may be longer.

Queue shown is maximum after two cycles.

Queues  
2: Shiloh Road & Hembree Ln

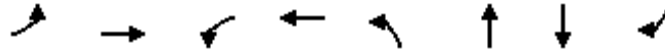

Lane Group	EBL	EBT	WBL	WBT	NBL	NBT	SBT	SBR
Lane Group Flow (vph)	703	932	110	1026	111	149	194	554
v/c Ratio	0.99	0.91	0.93	0.71	0.94	0.66	0.90	0.96
Control Delay	68.9	31.2	111.9	22.5	113.9	26.1	81.0	52.7
Queue Delay	0.0	0.6	0.0	0.0	0.0	0.0	0.0	0.0
Total Delay	68.9	31.8	111.9	22.5	113.9	26.1	81.0	52.7
Queue Length 50th (ft)	~222	402	62	220	~63	11	109	~209
Queue Length 95th (ft)	#342	#693	#171	272	#173	#91	#246	#516
Internal Link Dist (ft)		222		1709		136	301	
Turn Bay Length (ft)			100					
Base Capacity (vph)	707	1186	118	1753	118	227	215	575
Starvation Cap Reductn	0	60	0	0	0	0	0	0
Spillback Cap Reductn	0	0	0	0	0	0	0	0
Storage Cap Reductn	0	0	0	0	0	0	0	0
Reduced v/c Ratio	0.99	0.83	0.93	0.59	0.94	0.66	0.90	0.96

**Intersection Summary**

~ Volume exceeds capacity, queue is theoretically infinite.  
Queue shown is maximum after two cycles.

# 95th percentile volume exceeds capacity, queue may be longer.  
Queue shown is maximum after two cycles.



Queues  
3: US 101 NB Off-Ramp & Shiloh Road

General Plan 2040 Conditions  
Timing Plan: P.M. Peak



Lane Group	EBT	WBT	NBL	NBR
Lane Group Flow (vph)	810	898	771	819
v/c Ratio	0.50	1.05	1.01	0.63
Control Delay	15.0	67.9	58.8	14.6
Queue Delay	0.0	0.0	0.0	0.0
Total Delay	15.0	67.9	58.8	14.6
Queue Length 50th (ft)	126	~445	~339	118
Queue Length 95th (ft)	174	#657	#571	180
Internal Link Dist (ft)	106	291	689	
Turn Bay Length (ft)				265
Base Capacity (vph)	1622	853	762	1305
Starvation Cap Reductn	0	0	0	0
Spillback Cap Reductn	0	0	0	0
Storage Cap Reductn	0	0	0	0
Reduced v/c Ratio	0.50	1.05	1.01	0.63

Intersection Summary

- ~ Volume exceeds capacity, queue is theoretically infinite.  
Queue shown is maximum after two cycles.
- # 95th percentile volume exceeds capacity, queue may be longer.  
Queue shown is maximum after two cycles.

Queues

4: Shiloh Road & US 101 SB Off-Ramp

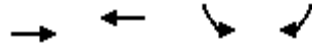

Lane Group	EBT	WBT	SBL	SBR
Lane Group Flow (vph)	716	1103	346	101
v/c Ratio	0.59	0.91	0.83	0.23
Control Delay	8.9	22.1	50.6	8.6
Queue Delay	0.0	0.0	0.0	0.0
Total Delay	8.9	22.1	50.6	8.6
Queue Length 50th (ft)	154	357	156	0
Queue Length 95th (ft)	223	576	#381	41
Internal Link Dist (ft)	145	226	406	
Turn Bay Length (ft)				275
Base Capacity (vph)	1609	1609	416	441
Starvation Cap Reductn	0	0	0	0
Spillback Cap Reductn	0	0	0	0
Storage Cap Reductn	0	0	0	0
Reduced v/c Ratio	0.44	0.69	0.83	0.23

Intersection Summary

# 95th percentile volume exceeds capacity, queue may be longer.  
 Queue shown is maximum after two cycles.

Queues  
6: Conde Lane & Shiloh Road

General Plan 2040 Conditions  
Timing Plan: P.M. Peak

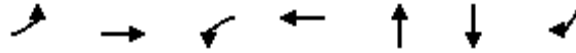

Lane Group	EBL	EBT	WBL	WBT	NBT	SBT	SBR
Lane Group Flow (vph)	88	798	11	1368	34	445	74
v/c Ratio	0.45	0.36	0.06	0.75	0.14	1.75	0.09
Control Delay	44.0	9.3	37.1	19.0	19.5	381.4	12.6
Queue Delay	0.0	0.0	0.0	0.0	0.0	0.0	0.0
Total Delay	44.0	9.3	37.1	19.0	19.5	381.4	12.6
Queue Length 50th (ft)	46	102	6	312	4	~384	22
Queue Length 95th (ft)	91	189	19	328	18	#549	44
Internal Link Dist (ft)		735		1001	338	442	
Turn Bay Length (ft)	90		127				40
Base Capacity (vph)	207	2236	184	1822	728	254	844
Starvation Cap Reductn	0	0	0	0	0	0	0
Spillback Cap Reductn	0	0	0	0	0	0	0
Storage Cap Reductn	0	0	0	0	0	0	0
Reduced v/c Ratio	0.43	0.36	0.06	0.75	0.05	1.75	0.09

Intersection Summary

~ Volume exceeds capacity, queue is theoretically infinite.  
Queue shown is maximum after two cycles.

# 95th percentile volume exceeds capacity, queue may be longer.  
Queue shown is maximum after two cycles.

Queues

10: US 101 NB Off Ramp/Lakewood Drive & Old Redwood Highway



Lane Group	EBL	EBT	WBT	NBL	NBT	SBL	SBR
Lane Group Flow (vph)	355	772	1083	499	990	402	644
v/c Ratio	1.03	0.93	1.02	0.96	0.91	1.51	0.73
Control Delay	99.4	43.0	63.4	63.3	40.3	277.9	17.0
Queue Delay	0.0	0.0	0.0	0.0	0.0	0.0	0.0
Total Delay	99.4	43.0	63.4	63.3	40.3	277.9	17.0
Queue Length 50th (ft)	~112	401	~320	303	270	~165	174
Queue Length 95th (ft)	#189	#606	#461	#523	#401	#256	317
Internal Link Dist (ft)		146	537		636		
Turn Bay Length (ft)	155			270		120	
Base Capacity (vph)	343	832	1062	518	1087	267	881
Starvation Cap Reductn	0	0	0	0	0	0	0
Spillback Cap Reductn	0	0	0	0	0	0	0
Storage Cap Reductn	0	0	0	0	0	0	0
Reduced v/c Ratio	1.03	0.93	1.02	0.96	0.91	1.51	0.73

Intersection Summary

~ Volume exceeds capacity, queue is theoretically infinite.

Queue shown is maximum after two cycles.

# 95th percentile volume exceeds capacity, queue may be longer.

Queue shown is maximum after two cycles.

Queues

12: US 101 SB On Ramp/US 101 SB Off Ramp & Old Redwood Highway



Lane Group	EBT	EBR	WBL	WBT	SBL	SBT
Lane Group Flow (vph)	651	533	498	1260	327	304
v/c Ratio	0.46	0.60	1.09	0.50	1.32	0.99
Control Delay	16.8	6.4	98.8	5.3	200.3	72.4
Queue Delay	0.0	0.0	0.0	0.0	0.0	0.0
Total Delay	16.8	6.4	98.8	5.3	200.3	72.4
Queue Length 50th (ft)	105	24	~248	101	~196	95
Queue Length 95th (ft)	149	98	#412	133	#313	#220
Internal Link Dist (ft)	343			451		751
Turn Bay Length (ft)			250		420	
Base Capacity (vph)	1410	887	455	2522	247	308
Starvation Cap Reductn	0	0	0	0	0	0
Spillback Cap Reductn	0	0	0	0	0	0
Storage Cap Reductn	0	0	0	0	0	0
Reduced v/c Ratio	0.46	0.60	1.09	0.50	1.32	0.99

Intersection Summary

~ Volume exceeds capacity, queue is theoretically infinite.

Queue shown is maximum after two cycles.

# 95th percentile volume exceeds capacity, queue may be longer.

Queue shown is maximum after two cycles.

Queues  
1: Old Redwood Hwy & Shiloh Road

General Plan 2040 Conditions  
Timing Plan: Saturday Midday Peak



Lane Group	EBL	EBT	EBR	WBT	WBR	NBL	NBT	NBR	SBL	SBT	SBR
Lane Group Flow (vph)	204	118	243	158	26	238	363	38	33	299	292
v/c Ratio	0.58	0.32	0.49	0.53	0.07	0.76	0.48	0.06	0.27	0.67	0.59
Control Delay	38.9	32.8	8.1	41.1	0.4	53.2	23.7	0.5	48.8	37.2	18.0
Queue Delay	0.0	0.0	0.0	0.0	0.0	0.0	0.0	0.0	0.0	0.0	0.0
Total Delay	38.9	32.8	8.1	41.1	0.4	53.2	23.7	0.5	48.8	37.2	18.0
Queue Length 50th (ft)	93	51	0	74	0	115	145	0	16	136	52
Queue Length 95th (ft)	195	118	60	156	0	#337	289	2	55	266	155
Internal Link Dist (ft)		1709		528			668			695	
Turn Bay Length (ft)	375		140		50	200		98	130		93
Base Capacity (vph)	686	722	749	890	823	315	1030	893	123	829	777
Starvation Cap Reductn	0	0	0	0	0	0	0	0	0	0	0
Spillback Cap Reductn	0	0	0	0	0	0	0	0	0	0	0
Storage Cap Reductn	0	0	0	0	0	0	0	0	0	0	0
Reduced v/c Ratio	0.30	0.16	0.32	0.18	0.03	0.76	0.35	0.04	0.27	0.36	0.38

Intersection Summary

# 95th percentile volume exceeds capacity, queue may be longer.  
Queue shown is maximum after two cycles.

Queues  
2: Shiloh Road & Hembree Ln

General Plan 2040 Conditions  
Timing Plan: Saturday Midday Peak

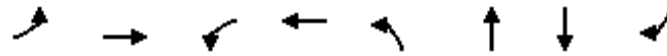

Lane Group	EBL	EBT	WBL	WBT	NBL	NBT	SBT	SBR
Lane Group Flow (vph)	977	465	110	555	111	149	270	941
v/c Ratio	1.06	0.61	0.72	0.58	0.73	0.58	0.96	1.03
Control Delay	74.1	17.1	60.2	13.5	60.8	20.2	78.6	50.7
Queue Delay	0.0	0.0	0.0	0.0	0.0	0.0	0.0	0.0
Total Delay	74.1	17.1	60.2	13.5	60.8	20.2	78.6	50.7
Queue Length 50th (ft)	~188	129	40	53	40	7	99	~106
Queue Length 95th (ft)	#504	198	#166	88	#168	#89	#345	#747
Internal Link Dist (ft)		222		1709		136	301	
Turn Bay Length (ft)			100					
Base Capacity (vph)	921	1528	153	2238	153	257	280	912
Starvation Cap Reductn	0	0	0	0	0	0	0	0
Spillback Cap Reductn	0	0	0	0	0	0	0	0
Storage Cap Reductn	0	0	0	0	0	0	0	0
Reduced v/c Ratio	1.06	0.30	0.72	0.25	0.73	0.58	0.96	1.03

Intersection Summary

- ~ Volume exceeds capacity, queue is theoretically infinite.  
Queue shown is maximum after two cycles.
- # 95th percentile volume exceeds capacity, queue may be longer.  
Queue shown is maximum after two cycles.

Queues  
3: US 101 NB Off-Ramp & Shiloh Road

General Plan 2040 Conditions  
Timing Plan: Saturday Midday Peak

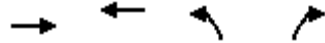

Lane Group	EBT	WBT	NBL	NBR
Lane Group Flow (vph)	575	1012	547	805
v/c Ratio	0.33	1.12	0.82	0.63
Control Delay	12.2	90.0	29.5	11.0
Queue Delay	0.0	0.0	0.0	0.0
Total Delay	12.2	90.0	29.5	11.0
Queue Length 50th (ft)	78	~529	195	75
Queue Length 95th (ft)	120	#765	312	132
Internal Link Dist (ft)	106	291	689	
Turn Bay Length (ft)				265
Base Capacity (vph)	1719	905	806	1468
Starvation Cap Reductn	0	0	0	0
Spillback Cap Reductn	0	0	0	0
Storage Cap Reductn	0	0	0	0
Reduced v/c Ratio	0.33	1.12	0.68	0.55

Intersection Summary

- ~ Volume exceeds capacity, queue is theoretically infinite.  
Queue shown is maximum after two cycles.
- # 95th percentile volume exceeds capacity, queue may be longer.  
Queue shown is maximum after two cycles.



Queues

4: Shiloh Road & US 101 SB Off-Ramp

General Plan 2040 Conditions

Timing Plan: Saturday Midday Peak

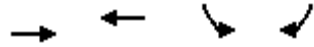

Lane Group	EBT	WBT	SBL	SBR
Lane Group Flow (vph)	407	792	365	328
v/c Ratio	0.42	0.81	0.67	0.49
Control Delay	8.8	17.8	27.9	8.3
Queue Delay	0.0	0.0	0.0	0.0
Total Delay	8.8	17.8	27.9	8.3
Queue Length 50th (ft)	71	187	100	16
Queue Length 95th (ft)	115	302	168	38
Internal Link Dist (ft)	145	226	406	
Turn Bay Length (ft)				275
Base Capacity (vph)	1840	1840	544	666
Starvation Cap Reductn	0	0	0	0
Spillback Cap Reductn	0	0	0	0
Storage Cap Reductn	0	0	0	0
Reduced v/c Ratio	0.22	0.43	0.67	0.49

Intersection Summary

Queues  
6: Conde Lane & Shiloh Road

General Plan 2040 Conditions  
Timing Plan: Saturday Midday Peak

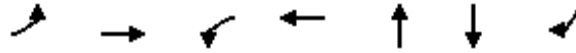

Lane Group	EBL	EBT	WBL	WBT	NBT	SBT	SBR
Lane Group Flow (vph)	45	544	14	968	18	373	53
v/c Ratio	0.16	0.30	0.05	0.66	0.04	0.98	0.08
Control Delay	31.9	9.9	32.2	15.8	0.2	74.4	13.3
Queue Delay	0.0	0.0	0.0	0.0	0.0	0.0	0.0
Total Delay	31.9	9.9	32.2	15.8	0.2	74.4	13.3
Queue Length 50th (ft)	13	33	4	116	0	~139	10
Queue Length 95th (ft)	54	134	25	248	0	#377	31
Internal Link Dist (ft)		735		1001	338	442	
Turn Bay Length (ft)	90		127				40
Base Capacity (vph)	295	2704	278	2541	1092	382	1196
Starvation Cap Reductn	0	0	0	0	0	0	0
Spillback Cap Reductn	0	0	0	0	0	0	0
Storage Cap Reductn	0	0	0	0	0	0	0
Reduced v/c Ratio	0.15	0.20	0.05	0.38	0.02	0.98	0.04

Intersection Summary

~ Volume exceeds capacity, queue is theoretically infinite.

Queue shown is maximum after two cycles.

# 95th percentile volume exceeds capacity, queue may be longer.

Queue shown is maximum after two cycles.

Queues

General Plan 2040 Conditions

10: US 101 NB Off Ramp/Lakewood Drive & Old Redwood Highway Timing Plan: Saturday Midday Peak



Lane Group	EBL	EBT	WBT	NBL	NBT	SBL	SBR
Lane Group Flow (vph)	392	427	1132	338	675	359	1032
v/c Ratio	1.31	0.48	0.95	0.73	0.70	1.29	1.26
Control Delay	195.7	18.6	42.7	37.9	28.9	188.2	147.3
Queue Delay	0.0	0.0	0.0	0.0	0.0	0.0	0.0
Total Delay	195.7	18.6	42.7	37.9	28.9	188.2	147.3
Queue Length 50th (ft)	~150	161	297	180	162	~135	~637
Queue Length 95th (ft)	#244	254	#447	285	224	#220	#851
Internal Link Dist (ft)		146	537		636		
Turn Bay Length (ft)	155			270		120	
Base Capacity (vph)	299	884	1197	547	1134	279	819
Starvation Cap Reductn	0	0	0	0	0	0	0
Spillback Cap Reductn	0	0	0	0	0	0	0
Storage Cap Reductn	0	0	0	0	0	0	0
Reduced v/c Ratio	1.31	0.48	0.95	0.62	0.60	1.29	1.26

Intersection Summary

~ Volume exceeds capacity, queue is theoretically infinite.

Queue shown is maximum after two cycles.

# 95th percentile volume exceeds capacity, queue may be longer.

Queue shown is maximum after two cycles.

Queues

General Plan 2040 Conditions

12: US 101 SB On Ramp/US 101 SB Off Ramp & Old Redwood Highway Timing Plan: Saturday Midday Peak

























Lane Group	EBT	EBR	WBL	WBT	SBL	SBT
Lane Group Flow (vph)	735	560	658	1104	223	206
v/c Ratio	0.52	0.65	1.41	0.43	0.91	0.60
Control Delay	17.7	8.7	222.1	4.4	72.4	18.2
Queue Delay	0.0	0.0	0.0	0.0	0.0	0.0
Total Delay	17.7	8.7	222.1	4.4	72.4	18.2
Queue Length 50th (ft)	123	42	~389	77	101	26
Queue Length 95th (ft)	171	136	#579	105	#158	55
Internal Link Dist (ft)	343			451		751
Turn Bay Length (ft)			250		420	
Base Capacity (vph)	1405	863	467	2568	244	346
Starvation Cap Reductn	0	0	0	0	0	0
Spillback Cap Reductn	0	0	0	0	0	0
Storage Cap Reductn	0	0	0	0	0	0
Reduced v/c Ratio	0.52	0.65	1.41	0.43	0.91	0.60

Intersection Summary

- ~ Volume exceeds capacity, queue is theoretically infinite.  
Queue shown is maximum after two cycles.
- # 95th percentile volume exceeds capacity, queue may be longer.  
Queue shown is maximum after two cycles.

Lanes, Volumes, Timings  
1: Old Redwood Hwy & Shiloh Road

General Plan 2040 Conditions  
Timing Plan: A.M. PEAK

												
Lane Group	EBL	EBT	EBR	WBL	WBT	WBR	NBL	NBT	NBR	SBL	SBT	SBR
Lane Configurations												
Traffic Volume (vph)	313	140	401	40	123	14	337	308	18	31	473	398
Future Volume (vph)	313	140	401	40	123	14	337	308	18	31	473	398
Ideal Flow (vphpl)	1900	1900	1900	1900	1900	1900	1900	1900	1900	1900	1900	1900
Storage Length (ft)	375		140	0		50	200		98	130		93
Storage Lanes	1		1	0		1	1		1	1		1
Taper Length (ft)	50			25			60			93		
Lane Util. Factor	1.00	1.00	1.00	1.00	1.00	1.00	1.00	1.00	1.00	1.00	1.00	1.00
Ped Bike Factor												0.98
Frt			0.850			0.850			0.850			0.850
Flt Protected	0.950				0.988		0.950			0.950		
Satd. Flow (prot)	1770	1863	1583	0	1840	1583	1770	1863	1583	1770	1863	1583
Flt Permitted	0.950				0.988		0.950			0.950		
Satd. Flow (perm)	1770	1863	1583	0	1840	1583	1770	1863	1583	1770	1863	1549
Right Turn on Red			Yes			Yes			Yes			Yes
Satd. Flow (RTOR)			495			105			77			143
Link Speed (mph)		40			40			45			40	
Link Distance (ft)		1789			608			748			775	
Travel Time (s)		30.5			10.4			11.3			13.2	
Confl. Bikes (#/hr)												1
Peak Hour Factor	0.81	0.81	0.81	0.89	0.89	0.89	0.93	0.93	0.93	0.85	0.85	0.85
Adj. Flow (vph)	386	173	495	45	138	16	362	331	19	36	556	468
Shared Lane Traffic (%)												
Lane Group Flow (vph)	386	173	495	0	183	16	362	331	19	36	556	468
Enter Blocked Intersection	No	No	No	No	No	No	No	No	No	No	No	No
Lane Alignment	Left	Left	Right	Left	Left	Right	Left	Left	Right	Left	Left	Right
Median Width(ft)		12			12			12			12	
Link Offset(ft)		0			0			0			0	
Crosswalk Width(ft)		16			16			16			16	
Two way Left Turn Lane												
Headway Factor	1.00	1.00	1.00	1.00	1.00	1.00	1.00	1.00	1.00	1.00	1.00	1.00
Turning Speed (mph)	15		9	15		9	15		9	15		9
Number of Detectors	1	2	1	1	2	1	1	2	1	1	2	1
Detector Template	Left	Thru	Right	Left	Thru	Right	Left	Thru	Right	Left	Thru	Right
Leading Detector (ft)	20	100	20	20	100	20	20	100	20	20	100	20
Trailing Detector (ft)	0	0	0	0	0	0	0	0	0	0	0	0
Detector 1 Position(ft)	0	0	0	0	0	0	0	0	0	0	0	0
Detector 1 Size(ft)	20	6	20	20	6	20	20	6	20	20	6	20
Detector 1 Type	Cl+Ex	Cl+Ex	Cl+Ex	Cl+Ex	Cl+Ex	Cl+Ex	Cl+Ex	Cl+Ex	Cl+Ex	Cl+Ex	Cl+Ex	Cl+Ex
Detector 1 Channel												
Detector 1 Extend (s)	0.0	0.0	0.0	0.0	0.0	0.0	0.0	0.0	0.0	0.0	0.0	0.0
Detector 1 Queue (s)	0.0	0.0	0.0	0.0	0.0	0.0	0.0	0.0	0.0	0.0	0.0	0.0
Detector 1 Delay (s)	0.0	0.0	0.0	0.0	0.0	0.0	0.0	0.0	0.0	0.0	0.0	0.0
Detector 2 Position(ft)		94			94			94			94	
Detector 2 Size(ft)		6			6			6			6	
Detector 2 Type		Cl+Ex			Cl+Ex			Cl+Ex			Cl+Ex	
Detector 2 Channel												
Detector 2 Extend (s)		0.0			0.0			0.0			0.0	
Turn Type	Split	NA	Perm	Split	NA	Perm	Prot	NA	Perm	Prot	NA	Perm

Lanes, Volumes, Timings  
1: Old Redwood Hwy & Shiloh Road

General Plan 2040 Conditions  
Timing Plan: A.M. PEAK

Lane Group	EBL	EBT	EBR	WBL	WBT	WBR	NBL	NBT	NBR	SBL	SBT	SBR
Protected Phases	2	2		6	6		3	8		7	4	
Permitted Phases			2			6			8			4
Detector Phase	2	2	2	6	6	6	3	8	8	7	4	4
Switch Phase												
Minimum Initial (s)	5.0	5.0	5.0	5.0	5.0	5.0	5.0	5.0	5.0	5.0	5.0	5.0
Minimum Split (s)	34.5	34.5	34.5	42.5	42.5	42.5	8.5	46.5	46.5	8.5	39.5	39.5
Total Split (s)	35.0	35.0	35.0	42.5	42.5	42.5	18.0	48.0	48.0	9.5	39.5	39.5
Total Split (%)	25.9%	25.9%	25.9%	31.5%	31.5%	31.5%	13.3%	35.6%	35.6%	7.0%	29.3%	29.3%
Maximum Green (s)	30.5	30.5	30.5	38.0	38.0	38.0	14.5	43.5	43.5	6.0	35.0	35.0
Yellow Time (s)	3.5	3.5	3.5	3.5	3.5	3.5	3.0	3.5	3.5	3.0	3.5	3.5
All-Red Time (s)	1.0	1.0	1.0	1.0	1.0	1.0	0.5	1.0	1.0	0.5	1.0	1.0
Lost Time Adjust (s)	0.0	0.0	0.0		0.0	0.0	0.0	0.0	0.0	0.0	0.0	0.0
Total Lost Time (s)	4.5	4.5	4.5		4.5	4.5	3.5	4.5	4.5	3.5	4.5	4.5
Lead/Lag	Lead	Lead	Lead	Lag	Lag	Lag	Lead	Lag	Lag	Lead	Lag	Lag
Lead-Lag Optimize?	Yes	Yes	Yes	Yes	Yes	Yes	Yes	Yes	Yes	Yes	Yes	Yes
Vehicle Extension (s)	3.0	3.0	3.0	3.0	3.0	3.0	3.0	3.0	3.0	3.0	3.0	3.0
Recall Mode	None	None	None	None	None	None	None	None	None	None	None	None
Walk Time (s)	7.0	7.0	7.0	7.0	7.0	7.0		7.0	7.0		7.0	7.0
Flash Don't Walk (s)	23.0	23.0	23.0	31.0	31.0	31.0		35.0	35.0		28.0	28.0
Pedestrian Calls (#/hr)	0	0	0	0	0	0		0	0		0	0
Act Effct Green (s)	29.8	29.8	29.8		16.4	16.4	14.5	47.6	47.6	5.9	35.1	35.1
Actuated g/C Ratio	0.26	0.26	0.26		0.15	0.15	0.13	0.42	0.42	0.05	0.31	0.31
v/c Ratio	0.83	0.35	0.63		0.68	0.05	1.59	0.42	0.03	0.39	0.96	0.81
Control Delay (s/veh)	55.9	36.9	7.2		59.2	0.3	319.0	27.2	0.1	66.3	68.5	37.5
Queue Delay	0.0	0.0	0.0		0.0	0.0	0.0	0.0	0.0	0.0	0.0	0.0
Total Delay (s/veh)	55.9	36.9	7.2		59.2	0.3	319.0	27.2	0.1	66.3	68.5	37.5
LOS	E	D	A		E	A	F	C	A	E	E	D
Approach Delay (s/veh)		29.9			54.5			174.8			54.7	
Approach LOS		C			D			F			D	

Intersection Summary





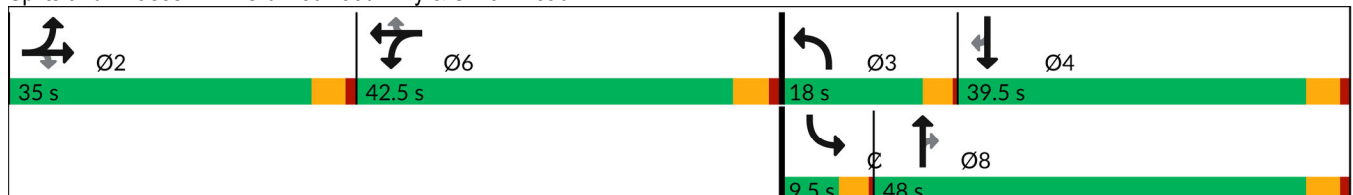















Area Type:	Other
Cycle Length:	135
Actuated Cycle Length:	112.9
Natural Cycle:	145
Control Type:	Actuated-Uncoordinated
Maximum v/c Ratio:	1.59
Intersection Signal Delay (s/veh):	74.3
Intersection LOS:	E
Intersection Capacity Utilization:	84.2%
ICU Level of Service:	E
Analysis Period (min):	15

Splits and Phases: 1: Old Redwood Hwy & Shiloh Road



Lanes, Volumes, Timings  
2: Shiloh Road & Hembree Ln

General Plan 2040 Conditions  
Timing Plan: A.M. PEAK

												
Lane Group	EBL	EBT	EBR	WBL	WBT	WBR	NBL	NBT	NBR	SBL	SBT	SBR
Lane Configurations												
Traffic Volume (vph)	311	709	103	49	719	90	49	11	16	129	18	570
Future Volume (vph)	311	709	103	49	719	90	49	11	16	129	18	570
Ideal Flow (vphpl)	1900	1900	1900	1900	1900	1900	1900	1900	1900	1900	1900	1900
Storage Length (ft)	0		0	100		130	0		0	0		0
Storage Lanes	2		0	1		1	1		0	0		1
Taper Length (ft)	25			50			25			25		
Lane Util. Factor	0.97	1.00	1.00	1.00	0.95	0.95	1.00	1.00	1.00	1.00	1.00	1.00
Frt		0.983			0.983			0.911				0.850
Flt Protected	0.950			0.950			0.950				0.958	
Satd. Flow (prot)	3433	1831	0	1770	3479	0	1770	1697	0	0	1785	1583
Flt Permitted	0.950			0.950			0.950				0.958	
Satd. Flow (perm)	3433	1831	0	1770	3479	0	1770	1697	0	0	1785	1583
Right Turn on Red			Yes			Yes			Yes			Yes
Satd. Flow (RTOR)		12			20			16				161
Link Speed (mph)		40			40			30				35
Link Distance (ft)		302			1789			216				381
Travel Time (s)		5.1			30.5			4.9				7.4
Peak Hour Factor	0.88	0.88	1.00	1.00	0.97	0.97	1.00	1.00	1.00	0.94	1.00	0.94
Adj. Flow (vph)	353	806	103	49	741	93	49	11	16	137	18	606
Shared Lane Traffic (%)												
Lane Group Flow (vph)	353	909	0	49	834	0	49	27	0	0	155	606
Enter Blocked Intersection	No	No	No	No	No	No	No	No	No	No	No	No
Lane Alignment	Left	Left	Right	Left	Left	Right	Left	Left	Right	Left	Left	Right
Median Width(ft)		24			24			12				12
Link Offset(ft)		0			0			0				0
Crosswalk Width(ft)		16			16			16				16
Two way Left Turn Lane												
Headway Factor	1.00	1.00	1.00	1.00	1.00	1.00	1.00	1.00	1.00	1.00	1.00	1.00
Turning Speed (mph)	15		60	60		9	60		60	15		9
Number of Detectors	1	2		1	2		1	2		1	2	1
Detector Template	Left	Thru		Left	Thru		Left	Thru		Left	Thru	Right
Leading Detector (ft)	20	100		20	100		20	100		20	100	20
Trailing Detector (ft)	0	0		0	0		0	0		0	0	0
Detector 1 Position(ft)	0	0		0	0		0	0		0	0	0
Detector 1 Size(ft)	20	6		20	6		20	6		20	6	20
Detector 1 Type	Cl+Ex	Cl+Ex		Cl+Ex	Cl+Ex		Cl+Ex	Cl+Ex		Cl+Ex	Cl+Ex	Cl+Ex
Detector 1 Channel												
Detector 1 Extend (s)	0.0	0.0		0.0	0.0		0.0	0.0		0.0	0.0	0.0
Detector 1 Queue (s)	0.0	0.0		0.0	0.0		0.0	0.0		0.0	0.0	0.0
Detector 1 Delay (s)	0.0	0.0		0.0	0.0		0.0	0.0		0.0	0.0	0.0
Detector 2 Position(ft)		94			94			94				94
Detector 2 Size(ft)		6			6			6				6
Detector 2 Type		Cl+Ex			Cl+Ex			Cl+Ex				Cl+Ex
Detector 2 Channel												
Detector 2 Extend (s)		0.0			0.0			0.0				0.0
Turn Type	Prot	NA		Prot	NA		Split	NA		Split	NA	pt+ov
Protected Phases	5	2		1	6		8	8		4	4	4
Permitted Phases												

Lanes, Volumes, Timings  
2: Shiloh Road & Hembree Ln

General Plan 2040 Conditions  
Timing Plan: A.M. PEAK

Lane Group	EBL	EBT	EBR	WBL	WBT	WBR	NBL	NBT	NBR	SBL	SBT	SBR
Detector Phase	5	2		1	6		8	8		4	4	4 5
Switch Phase												
Minimum Initial (s)	3.0	5.0		5.0	5.0		5.0	5.0		5.0	5.0	
Minimum Split (s)	7.5	9.5		9.5	43.5		9.5	9.5		9.5	9.5	
Total Split (s)	21.0	57.0		9.5	45.5		9.5	9.5		14.0	14.0	
Total Split (%)	23.3%	63.3%		10.6%	50.6%		10.6%	10.6%		15.6%	15.6%	
Maximum Green (s)	17.0	53.0		5.5	41.5		5.5	5.5		10.0	10.0	
Yellow Time (s)	3.0	3.0		3.0	3.0		3.0	3.0		3.0	3.0	
All-Red Time (s)	1.0	1.0		1.0	1.0		1.0	1.0		1.0	1.0	
Lost Time Adjust (s)	0.0	0.0		0.0	0.0		0.0	0.0		0.0	0.0	
Total Lost Time (s)	4.0	4.0		4.0	4.0		4.0	4.0		4.0	4.0	
Lead/Lag	Lead	Lag		Lead	Lag							
Lead-Lag Optimize?	Yes	Yes		Yes	Yes							
Vehicle Extension (s)	3.0	3.0		3.0	3.0		3.0	3.0		3.0	3.0	
Recall Mode	None	None		None	None		None	None		None	None	
Walk Time (s)					7.0							
Flash Don't Walk (s)					32.0							
Pedestrian Calls (#/hr)					1							
Act Effct Green (s)	17.8	47.1		5.8	30.0		5.8	5.8		10.5	30.5	
Actuated g/C Ratio	0.23	0.62		0.08	0.40		0.08	0.08		0.14	0.40	
v/c Ratio	0.44	0.80		0.37	0.60		0.37	0.19		0.63	0.83	
Control Delay (s/veh)	30.4	19.5		47.3	19.1		47.3	28.3		49.1	29.6	
Queue Delay	0.0	0.1		0.0	0.0		0.0	0.0		0.0	0.0	
Total Delay (s/veh)	30.4	19.6		47.3	19.1		47.3	28.3		49.1	29.6	
LOS	C	B		D	B		D	C		D	C	
Approach Delay (s/veh)		22.6			20.6			40.6			33.6	
Approach LOS		C			C			D			C	

Intersection Summary	
Area Type:	Other
Cycle Length:	90
Actuated Cycle Length:	75.8
Natural Cycle:	90
Control Type:	Actuated-Uncoordinated
Maximum v/c Ratio:	0.83
Intersection Signal Delay (s/veh):	25.3
Intersection LOS:	C
Intersection Capacity Utilization:	72.5%
ICU Level of Service:	C
Analysis Period (min):	15

Splits and Phases: 2: Shiloh Road & Hembree Ln

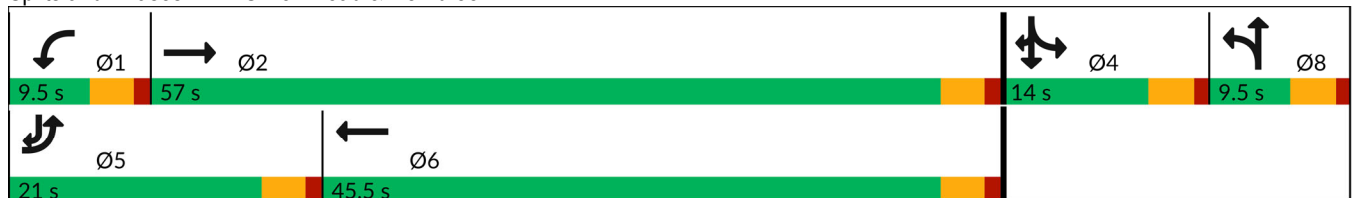



Lanes, Volumes, Timings  
 3: US 101 NB Off-Ramp & Shiloh Road

General Plan 2040 Conditions  
 Timing Plan: A.M. PEAK



Lane Group	EBT	EBR	WBL	WBT	NBL	NBR
Lane Configurations	↑↑			↑	↘	↗↗
Traffic Volume (vph)	648	0	0	1006	813	476
Future Volume (vph)	648	0	0	1006	813	476
Ideal Flow (vphpl)	1900	1900	1900	1900	1900	1900
Storage Length (ft)		0	0		0	265
Storage Lanes		0	0		1	2
Taper Length (ft)			25		25	
Lane Util. Factor	0.95	1.00	1.00	1.00	1.00	0.88
Frt						0.850
Flt Protected					0.950	
Satd. Flow (prot)	3539	0	0	1863	1770	2787
Flt Permitted					0.950	
Satd. Flow (perm)	3539	0	0	1863	1770	2787
Right Turn on Red		Yes				Yes
Satd. Flow (RTOR)						248
Link Speed (mph)	40			40	30	
Link Distance (ft)	186			371	769	
Travel Time (s)	3.2			6.3	17.5	
Peak Hour Factor	0.91	0.91	0.90	0.90	0.76	0.76
Adj. Flow (vph)	712	0	0	1118	1070	626
Shared Lane Traffic (%)						
Lane Group Flow (vph)	712	0	0	1118	1070	626
Enter Blocked Intersection	No	No	No	No	No	No
Lane Alignment	Left	Right	Left	Left	Left	Right
Median Width(ft)	0			0	12	
Link Offset(ft)	0			0	0	
Crosswalk Width(ft)	16			16	16	
Two way Left Turn Lane						
Headway Factor	1.00	1.00	1.00	1.00	1.00	1.00
Turning Speed (mph)		9	15		15	9
Number of Detectors	2			2	1	1
Detector Template	Thru			Thru	Left	Right
Leading Detector (ft)	100			100	20	20
Trailing Detector (ft)	0			0	0	0
Detector 1 Position(ft)	0			0	0	0
Detector 1 Size(ft)	6			6	20	20
Detector 1 Type	Cl+Ex			Cl+Ex	Cl+Ex	Cl+Ex
Detector 1 Channel						
Detector 1 Extend (s)	0.0			0.0	0.0	0.0
Detector 1 Queue (s)	0.0			0.0	0.0	0.0
Detector 1 Delay (s)	0.0			0.0	0.0	0.0
Detector 2 Position(ft)	94			94		
Detector 2 Size(ft)	6			6		
Detector 2 Type	Cl+Ex			Cl+Ex		
Detector 2 Channel						
Detector 2 Extend (s)	0.0			0.0		
Turn Type	NA			NA	Prot	Perm
Protected Phases	2			6	8	
Permitted Phases						8

Lanes, Volumes, Timings  
 3: US 101 NB Off-Ramp & Shiloh Road

General Plan 2040 Conditions  
 Timing Plan: A.M. PEAK



Lane Group	EBT	EBR	WBL	WBT	NBL	NBR
Detector Phase	2			6	8	8
Switch Phase						
Minimum Initial (s)	5.0			5.0	5.0	5.0
Minimum Split (s)	9.0			9.0	9.0	9.0
Total Split (s)	37.0			37.0	35.0	35.0
Total Split (%)	51.4%			51.4%	48.6%	48.6%
Maximum Green (s)	33.0			33.0	31.0	31.0
Yellow Time (s)	3.0			3.0	3.0	3.0
All-Red Time (s)	1.0			1.0	1.0	1.0
Lost Time Adjust (s)	0.0			0.0	0.0	0.0
Total Lost Time (s)	4.0			4.0	4.0	4.0
Lead/Lag						
Lead-Lag Optimize?						
Vehicle Extension (s)	3.0			3.0	3.0	3.0
Recall Mode	None			None	None	None
Act Effect Green (s)	33.0			33.0	31.0	31.0
Actuated g/C Ratio	0.46			0.46	0.43	0.43
v/c Ratio	0.44			1.31	1.40	0.47
Control Delay (s/veh)	14.3			170.5	212.4	9.7
Queue Delay	0.0			0.0	0.0	0.0
Total Delay (s/veh)	14.3			170.5	212.4	9.7
LOS	B			F	F	A
Approach Delay (s/veh)	14.3			170.5	137.6	
Approach LOS	B			F	F	

Intersection Summary

Area Type: Other  
 Cycle Length: 72  
 Actuated Cycle Length: 72  
 Natural Cycle: 140  
 Control Type: Actuated-Uncoordinated  
 Maximum v/c Ratio: 1.40  
 Intersection Signal Delay (s/veh): 123.1  
 Intersection LOS: F  
 Intersection Capacity Utilization 150.2%  
 ICU Level of Service H  
 Analysis Period (min) 15

Splits and Phases: 3: US 101 NB Off-Ramp & Shiloh Road

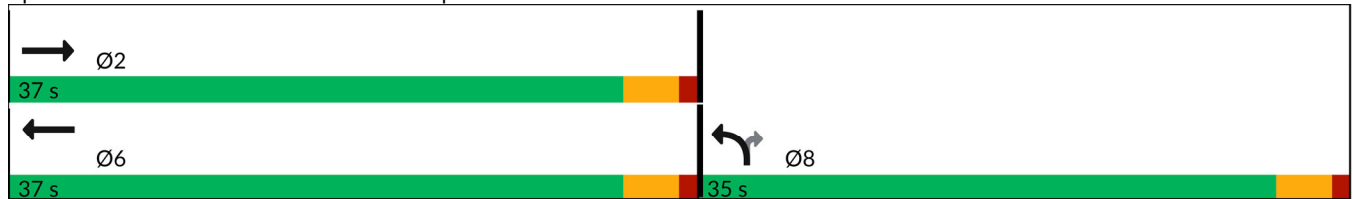

Lanes, Volumes, Timings  
4: Shiloh Road & US 101 SB Off-Ramp

General Plan 2040 Conditions  
Timing Plan: A.M. PEAK

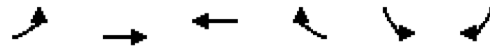

Lane Group	EBL	EBT	WBT	WBR	SBL	SBR
Lane Configurations		↑	↑		↘	↘
Traffic Volume (vph)	0	408	1143	0	240	184
Future Volume (vph)	0	408	1143	0	240	184
Ideal Flow (vphpl)	1900	1900	1900	1900	1900	1900
Storage Length (ft)	0			0	0	275
Storage Lanes	0			0	1	1
Taper Length (ft)	25				25	
Lane Util. Factor	1.00	1.00	1.00	1.00	1.00	1.00
Frt						0.850
Flt Protected					0.950	
Satd. Flow (prot)	0	1863	1863	0	1770	1583
Flt Permitted					0.950	
Satd. Flow (perm)	0	1863	1863	0	1770	1583
Right Turn on Red				Yes		Yes
Satd. Flow (RTOR)						109
Link Speed (mph)		40	40		30	
Link Distance (ft)		225	306		486	
Travel Time (s)		3.8	5.2		11.0	
Peak Hour Factor	0.93	0.93	0.91	0.91	0.92	0.92
Adj. Flow (vph)	0	439	1256	0	261	200
Shared Lane Traffic (%)						
Lane Group Flow (vph)	0	439	1256	0	261	200
Enter Blocked Intersection	No	No	No	No	No	No
Lane Alignment	Left	Left	Left	Right	Left	Right
Median Width(ft)		4	0		12	
Link Offset(ft)		0	0		0	
Crosswalk Width(ft)		16	16		16	
Two way Left Turn Lane						
Headway Factor	1.00	1.00	1.00	1.00	1.00	1.00
Turning Speed (mph)	15			9	15	9
Number of Detectors		2	2		1	1
Detector Template		Thru	Thru		Left	Right
Leading Detector (ft)		100	100		20	20
Trailing Detector (ft)		0	0		0	0
Detector 1 Position(ft)		0	0		0	0
Detector 1 Size(ft)		6	6		20	20
Detector 1 Type		Cl+Ex	Cl+Ex		Cl+Ex	Cl+Ex
Detector 1 Channel						
Detector 1 Extend (s)		0.0	0.0		0.0	0.0
Detector 1 Queue (s)		0.0	0.0		0.0	0.0
Detector 1 Delay (s)		0.0	0.0		0.0	0.0
Detector 2 Position(ft)		94	94			
Detector 2 Size(ft)		6	6			
Detector 2 Type		Cl+Ex	Cl+Ex			
Detector 2 Channel						
Detector 2 Extend (s)		0.0	0.0			
Turn Type		NA	NA		Perm	Perm
Protected Phases		2	6			
Permitted Phases					4	4

Lanes, Volumes, Timings  
4: Shiloh Road & US 101 SB Off-Ramp

General Plan 2040 Conditions  
Timing Plan: A.M. PEAK



Lane Group	EBL	EBT	WBT	WBR	SBL	SBR
Detector Phase		2	6		4	4
Switch Phase						
Minimum Initial (s)		5.0	5.0		5.0	5.0
Minimum Split (s)		9.0	38.0		9.0	9.0
Total Split (s)		69.0	69.0		21.0	21.0
Total Split (%)		76.7%	76.7%		23.3%	23.3%
Maximum Green (s)		65.0	65.0		17.0	17.0
Yellow Time (s)		3.0	3.0		3.0	3.0
All-Red Time (s)		1.0	1.0		1.0	1.0
Lost Time Adjust (s)		0.0	0.0		0.0	0.0
Total Lost Time (s)		4.0	4.0		4.0	4.0
Lead/Lag						
Lead-Lag Optimize?						
Vehicle Extension (s)		3.0	3.0		3.0	3.0
Recall Mode		None	None		None	None
Walk Time (s)			7.0			
Flash Don't Walk (s)			27.0			
Pedestrian Calls (#/hr)			0			
Act Effct Green (s)		59.4	59.4		15.5	15.5
Actuated g/C Ratio		0.71	0.71		0.19	0.19
v/c Ratio		0.33	0.94		0.79	0.52
Control Delay (s/veh)		5.2	26.6		52.6	21.2
Queue Delay		0.0	0.0		0.0	0.0
Total Delay (s/veh)		5.2	26.6		52.6	21.2
LOS		A	C		D	C
Approach Delay (s/veh)		5.2	26.6		39.0	
Approach LOS		A	C		D	

Intersection Summary	
Area Type:	Other
Cycle Length:	90
Actuated Cycle Length:	83.1
Natural Cycle:	90
Control Type:	Actuated-Uncoordinated
Maximum v/c Ratio:	0.94
Intersection Signal Delay (s/veh):	24.9
Intersection LOS:	C
Intersection Capacity Utilization:	134.6%
ICU Level of Service:	H
Analysis Period (min):	15

Splits and Phases: 4: Shiloh Road & US 101 SB Off-Ramp

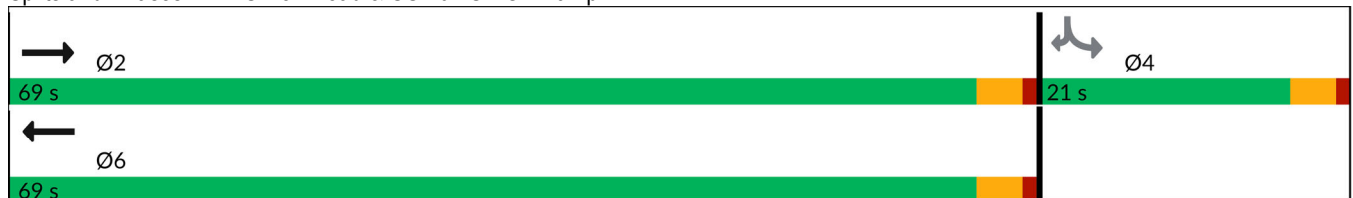



















Lanes, Volumes, Timings  
5: Caletti Ave & Shiloh Road

General Plan 2040 Conditions  
Timing Plan: A.M. PEAK

	→	↘	↙	←	↖	↗
Lane Group	EBT	EBR	WBL	WBT	NBL	NBR
Lane Configurations	↑↑		↘	↑	↖	↗
Traffic Volume (vph)	886	14	130	1197	17	122
Future Volume (vph)	886	14	130	1197	17	122
Ideal Flow (vphpl)	1900	1900	1900	1900	1900	1900
Storage Length (ft)		0	68		0	0
Storage Lanes		0	1		1	1
Taper Length (ft)			50		25	
Lane Util. Factor	0.95	0.95	1.00	1.00	1.00	1.00
Frt	0.998					0.850
Flt Protected			0.950		0.950	
Satd. Flow (prot)	3532	0	1770	1863	1770	1583
Flt Permitted			0.950		0.950	
Satd. Flow (perm)	3532	0	1770	1863	1770	1583
Link Speed (mph)	40			40	30	
Link Distance (ft)	1081			184	459	
Travel Time (s)	18.4			3.1	10.4	
Peak Hour Factor	0.96	0.96	0.87	0.87	0.84	0.84
Adj. Flow (vph)	923	15	149	1376	20	145
Shared Lane Traffic (%)						
Lane Group Flow (vph)	938	0	149	1376	20	145
Enter Blocked Intersection	No	No	No	No	No	No
Lane Alignment	Left	Right	Left	Left	Left	Right
Median Width(ft)	12			12	12	
Link Offset(ft)	0			0	0	
Crosswalk Width(ft)	16			16	16	
Two way Left Turn Lane						
Headway Factor	1.00	1.00	1.00	1.00	1.00	1.00
Turning Speed (mph)		9	15		15	9
Sign Control	Free			Free	Stop	
<b>Intersection Summary</b>						
Area Type:	Other					
Control Type:	Unsignalized					
Intersection Capacity Utilization	73.0%			ICU Level of Service C		
Analysis Period (min)	15					

Lanes, Volumes, Timings  
6: Conde Lane & Shiloh Road

General Plan 2040 Conditions  
Timing Plan: A.M. PEAK

												
Lane Group	EBL	EBT	EBR	WBL	WBT	WBR	NBL	NBT	NBR	SBL	SBT	SBR
Lane Configurations												
Traffic Volume (vph)	55	521	3	8	844	298	2	1	9	363	0	27
Future Volume (vph)	55	521	3	8	844	298	2	1	9	363	0	27
Ideal Flow (vphpl)	1900	1900	1900	1900	1900	1900	1900	1900	1900	1900	1900	1900
Storage Length (ft)	90		0	127		0	0		0	0		40
Storage Lanes	1		0	1		0	0		0	0		1
Taper Length (ft)	70			40			25			25		
Lane Util. Factor	1.00	0.95	0.95	1.00	0.95	0.95	1.00	1.00	1.00	1.00	1.00	1.00
Frt		0.999			0.961			0.902				0.850
Flt Protected	0.950			0.950				0.991			0.950	
Satd. Flow (prot)	1770	3536	0	1770	3401	0	0	1665	0	0	1770	1583
Flt Permitted	0.950			0.950				0.991			0.950	
Satd. Flow (perm)	1770	3536	0	1770	3401	0	0	1665	0	0	1770	1583
Right Turn on Red			Yes			Yes			Yes			No
Satd. Flow (RTOR)		1			51			16				
Link Speed (mph)		40			40			30				35
Link Distance (ft)		815			1081			418				522
Travel Time (s)		13.9			18.4			9.5				10.2
Peak Hour Factor	0.95	0.95	0.95	0.85	0.85	0.85	0.57	0.57	0.57	0.86	0.86	0.86
Adj. Flow (vph)	58	548	3	9	993	351	4	2	16	422	0	31
Shared Lane Traffic (%)												
Lane Group Flow (vph)	58	551	0	9	1344	0	0	22	0	0	422	31
Enter Blocked Intersection	No	No	No	No	No	No	No	No	No	No	No	No
Lane Alignment	Left	Left	Right	Left	Left	Right	Left	Left	Right	Left	Left	Right
Median Width(ft)		12			12			0				0
Link Offset(ft)		0			0			0				0
Crosswalk Width(ft)		16			16			16				16
Two way Left Turn Lane												
Headway Factor	1.00	1.00	1.00	1.00	1.00	1.00	1.00	1.00	1.00	1.00	1.00	1.00
Turning Speed (mph)	15		9	15		9	15		9	15		9
Number of Detectors	1	2		1	2		1	2		1	1	1
Detector Template	Left	Thru		Left	Thru		Left	Thru		Left	Thru	Right
Leading Detector (ft)	20	100		20	100		20	100		20	30	20
Trailing Detector (ft)	0	0		0	0		0	0		0	0	0
Detector 1 Position(ft)	0	0		0	0		0	0		0	0	0
Detector 1 Size(ft)	20	6		20	6		20	6		20	30	20
Detector 1 Type	Cl+Ex	Cl+Ex		Cl+Ex	Cl+Ex		Cl+Ex	Cl+Ex		Cl+Ex	Cl+Ex	Cl+Ex
Detector 1 Channel												
Detector 1 Extend (s)	0.0	0.0		0.0	0.0		0.0	0.0		0.0	0.0	0.0
Detector 1 Queue (s)	0.0	0.0		0.0	0.0		0.0	0.0		0.0	0.0	0.0
Detector 1 Delay (s)	0.0	0.0		0.0	0.0		0.0	0.0		0.0	0.0	0.0
Detector 2 Position(ft)		94			94			94				
Detector 2 Size(ft)		6			6			6				
Detector 2 Type		Cl+Ex			Cl+Ex			Cl+Ex				
Detector 2 Channel												
Detector 2 Extend (s)		0.0			0.0			0.0				
Turn Type	Prot	NA		Prot	NA		Split	NA		Split	NA	custom
Protected Phases	5	2		1	6		7	7		4	4	
Permitted Phases												6

Lanes, Volumes, Timings  
6: Conde Lane & Shiloh Road

General Plan 2040 Conditions  
Timing Plan: A.M. PEAK

Lane Group	EBL	EBT	EBR	WBL	WBT	WBR	NBL	NBT	NBR	SBL	SBT	SBR
Detector Phase	5	2		1	6		7	7		4	4	6
Switch Phase												
Minimum Initial (s)	8.0	8.0		8.0	8.0		10.0	10.0		11.0	11.0	8.0
Minimum Split (s)	12.0	46.0		12.0	12.0		37.0	37.0		15.0	15.0	12.0
Total Split (s)	13.0	46.0		12.0	45.0		37.0	37.0		15.0	15.0	45.0
Total Split (%)	11.8%	41.8%		10.9%	40.9%		33.6%	33.6%		13.6%	13.6%	40.9%
Maximum Green (s)	9.0	42.0		8.0	41.0		33.0	33.0		11.0	11.0	41.0
Yellow Time (s)	3.0	3.0		3.0	3.0		3.0	3.0		3.0	3.0	3.0
All-Red Time (s)	1.0	1.0		1.0	1.0		1.0	1.0		1.0	1.0	1.0
Lost Time Adjust (s)	0.0	0.0		0.0	0.0		0.0	0.0		0.0	0.0	0.0
Total Lost Time (s)	4.0	4.0		4.0	4.0		4.0	4.0		4.0	4.0	4.0
Lead/Lag	Lead	Lag		Lead	Lag							Lag
Lead-Lag Optimize?	Yes	Yes		Yes	Yes							Yes
Vehicle Extension (s)	3.0	3.0		3.0	3.0		3.0	3.0		3.0	3.0	3.0
Recall Mode	None	None		None	None		None	None		None	None	None
Walk Time (s)		7.0					7.0	7.0				
Flash Don't Walk (s)		35.0					26.0	26.0				
Pedestrian Calls (#/hr)		0					0	0				
Act Effct Green (s)	8.6	46.7		8.2	42.0		10.3			11.3		42.0
Actuated g/C Ratio	0.12	0.64		0.11	0.58		0.14			0.15		0.58
v/c Ratio	0.28	0.24		0.05	0.68		0.09			1.54		0.03
Control Delay (s/veh)	37.6	7.7		35.8	15.5		20.8			288.2		11.2
Queue Delay	0.0	0.0		0.0	0.0		0.0			0.0		0.0
Total Delay (s/veh)	37.6	7.7		35.8	15.5		20.8			288.2		11.2
LOS	D	A		D	B		C			F		B
Approach Delay (s/veh)		10.5			15.7		20.8			269.2		
Approach LOS		B			B		C			F		

Intersection Summary





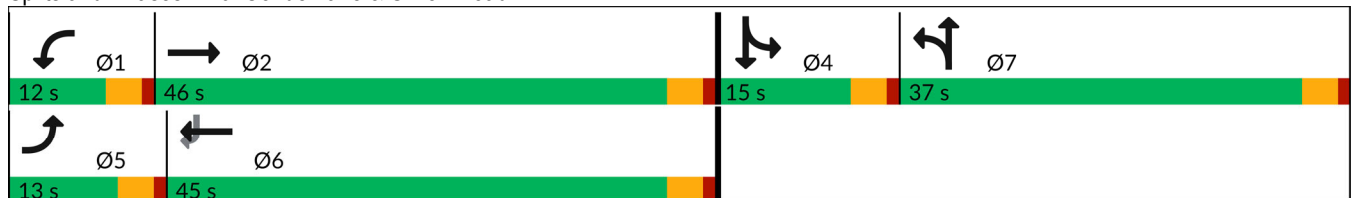











Area Type:	Other
Cycle Length:	110
Actuated Cycle Length:	73
Natural Cycle:	140
Control Type:	Actuated-Uncoordinated
Maximum v/c Ratio:	1.54
Intersection Signal Delay (s/veh):	61.6
Intersection LOS:	E
Intersection Capacity Utilization:	76.3%
ICU Level of Service:	D
Analysis Period (min):	15

Splits and Phases: 6: Conde Lane & Shiloh Road



Lanes, Volumes, Timings  
7: Entrance 1/Gridley Drive & Shiloh Road



















General Plan 2040 Conditions  
Timing Plan: A.M. PEAK

													
Lane Group	EBL	EBT	EBR	WBL	WBT	WBR	NBL	NBT	NBR	SBL	SBT	SBR	
Lane Configurations													
Traffic Volume (vph)	12	208	0	0	86	0	0	0	0	1	0	24	
Future Volume (vph)	12	208	0	0	86	0	0	0	0	1	0	24	
Ideal Flow (vphpl)	1900	1900	1900	1900	1900	1900	1900	1900	1900	1900	1900	1900	
Lane Util. Factor	1.00	1.00	1.00	1.00	1.00	1.00	1.00	1.00	1.00	1.00	1.00	1.00	
Ped Bike Factor													
Frt												0.869	
Flt Protected	0.997											0.999	
Satd. Flow (prot)	0	1857	0	0	1863	0	1863	1863	0	0	1617	0	
Flt Permitted	0.997											0.999	
Satd. Flow (perm)	0	1857	0	0	1863	0	1863	1863	0	0	1617	0	
Link Speed (mph)					40					30			30
Link Distance (ft)					608					2146			248
Travel Time (s)					10.4					36.6			5.6
Confl. Bikes (#/hr)			1										
Peak Hour Factor	0.91	0.91	0.91	0.85	0.85	0.85	1.00	1.00	1.00	0.71	0.71	0.71	
Adj. Flow (vph)	13	229	0	0	101	0	0	0	0	1	0	34	
Shared Lane Traffic (%)													
Lane Group Flow (vph)	0	242	0	0	101	0	0	0	0	0	35	0	
Enter Blocked Intersection	No	No	No	No	No	No	No	No	No	No	No	No	
Lane Alignment	Left	Left	Right	Left	Left	Right	Left	Left	Right	Left	Left	Right	
Median Width(ft)	0						0					12	12
Link Offset(ft)	0						0					0	0
Crosswalk Width(ft)	16						16					16	16
Two way Left Turn Lane													
Headway Factor	1.00	1.00	1.00	1.00	1.00	1.00	1.00	1.00	1.00	1.00	1.00	1.00	
Turning Speed (mph)	15	9		15	9		15	9		15	9		
Sign Control	Free						Free					Stop	Stop
<b>Intersection Summary</b>													
Area Type:	Other												
Control Type:	Unsignalized												
Intersection Capacity Utilization	28.3%						ICU Level of Service A						
Analysis Period (min)	15												













Lanes, Volumes, Timings  
8: Old Redwood Hwy & Entrance 1

General Plan 2040 Conditions  
Timing Plan: A.M. PEAK

												
Lane Group	EBL	EBT	EBR	WBL	WBT	WBR	NBL	NBT	NBR	SBL	SBT	SBR
Lane Configurations												
Traffic Volume (vph)	1	0	0	0	0	0	0	662	0	0	914	0
Future Volume (vph)	1	0	0	0	0	0	0	662	0	0	914	0
Ideal Flow (vphp)	1900	1900	1900	1900	1900	1900	1900	1900	1900	1900	1900	1900
Storage Length (ft)	0		0	0		0	0		0	50		0
Storage Lanes	0		0	1		0	0		0	1		0
Taper Length (ft)	25			25			25			25		
Lane Util. Factor	1.00	1.00	1.00	1.00	1.00	1.00	1.00	1.00	1.00	1.00	1.00	1.00
Ped Bike Factor												
Fr <sub>t</sub>												
Fl <sub>t</sub> Protected		0.950										
Satd. Flow (prot)	0	1770	0	1863	1863	0	0	1863	0	1863	1863	0
Fl <sub>t</sub> Permitted		0.950										
Satd. Flow (perm)	0	1770	0	1863	1863	0	0	1863	0	1863	1863	0
Link Speed (mph)		30			30			45			45	
Link Distance (ft)		98			385			520			748	
Travel Time (s)		2.2			8.8			7.9			11.3	
Confl. Peds. (#/hr)									1	1		
Confl. Bikes (#/hr)									1			2
Peak Hour Factor	0.25	0.25	0.25	1.00	1.00	1.00	0.99	0.99	0.99	0.90	0.90	0.90
Adj. Flow (vph)	4	0	0	0	0	0	0	669	0	0	1016	0
Shared Lane Traffic (%)												
Lane Group Flow (vph)	0	4	0	0	0	0	0	669	0	0	1016	0
Enter Blocked Intersection	No	No	No	No	No	No	No	No	No	No	No	No
Lane Alignment	Left	Left	Right	Left	Left	Right	Left	Left	Right	Left	Left	Right
Median Width(ft)		12			12			12			12	
Link Offset(ft)		0			0			0			0	
Crosswalk Width(ft)		16			16			16			16	
Two way Left Turn Lane												
Headway Factor	1.00	1.00	1.00	1.00	1.00	1.00	1.00	1.00	1.00	1.00	1.00	1.00
Turning Speed (mph)	15		9	15		9	15		9	15		9
Sign Control		Stop			Stop			Free			Free	
<b>Intersection Summary</b>												
Area Type:	Other											
Control Type:	Unsignalized											
Intersection Capacity Utilization	58.1%						ICU Level of Service B					
Analysis Period (min)	15											

Lanes, Volumes, Timings  
9: Entrance 2 & Shiloh Road

General Plan 2040 Conditions  
Timing Plan: A.M. PEAK

						
Lane Group	EBT	EBR	WBL	WBT	NBL	NBR
Lane Configurations						
Traffic Volume (vph)	207	0	0	77	0	0
Future Volume (vph)	207	0	0	77	0	0
Ideal Flow (vphpl)	1900	1900	1900	1900	1900	1900
Lane Util. Factor	1.00	1.00	1.00	1.00	1.00	1.00
<b>Fr</b>						
<b>Flt Protected</b>						
Satd. Flow (prot)	1863	0	0	1863	1863	1863
<b>Flt Permitted</b>						
Satd. Flow (perm)	1863	0	0	1863	1863	1863
Link Speed (mph)	40			40	30	
Link Distance (ft)	2146			134	402	
Travel Time (s)	36.6			2.3	9.1	
Peak Hour Factor	0.85	0.85	0.81	0.81	1.00	1.00
Adj. Flow (vph)	244	0	0	95	0	0
<b>Shared Lane Traffic (%)</b>						
Lane Group Flow (vph)	244	0	0	95	0	0
Enter Blocked Intersection	No	No	No	No	No	No
Lane Alignment	Left	Right	Left	Left	Left	Right
Median Width(ft)	0			0	12	
Link Offset(ft)	0			0	0	
Crosswalk Width(ft)	16			16	16	
<b>Two way Left Turn Lane</b>						
Headway Factor	1.00	1.00	1.00	1.00	1.00	1.00
Turning Speed (mph)		9	15		15	9
Sign Control	Free			Free	Stop	
<b>Intersection Summary</b>						
Area Type:	Other					
Control Type:	Unsignalized					
Intersection Capacity Utilization	14.2%			ICU Level of Service A		
Analysis Period (min)	15					

Lanes, Volumes, Timings

General Plan 2040 Conditions

10: US 101 NB Off Ramp/Lakewood Drive & Old Redwood Highway

Timing Plan: A.M. PEAK



Lane Group	EBL	EBT	EBR	WBL	WBT	WBR	NBL	NBT	NBR	SBL	SBT	SBR
Lane Configurations												
Traffic Volume (vph)	264	610	0	0	650	156	224	255	92	255	0	679
Future Volume (vph)	264	610	0	0	650	156	224	255	92	255	0	679
Ideal Flow (vphpl)	1900	1900	1900	1900	1900	1900	1900	1900	1900	1900	1900	1900
Storage Length (ft)	155		0	0		0	270		150	120		0
Storage Lanes	1		0	0		0	1		1	1		1
Taper Length (ft)	50			25			165			75		
Lane Util. Factor	0.97	1.00	1.00	1.00	0.95	0.95	0.91	0.91	0.95	0.97	1.00	1.00
Ped Bike Factor	1.00				1.00			1.00		1.00		
Flt					0.971			0.964				0.850
Flt Protected	0.950						0.950	0.996		0.950		
Satd. Flow (prot)	3433	1863	0	0	3427	0	1610	3244	0	3433	0	1583
Flt Permitted	0.950						0.950	0.996		0.950		
Satd. Flow (perm)	3431	1863	0	0	3427	0	1610	3244	0	3427	0	1583
Right Turn on Red			Yes			Yes			Yes			Yes
Satd. Flow (RTOR)					33			46				249
Link Speed (mph)		35			35			30				30
Link Distance (ft)		226			617			716				478
Travel Time (s)		4.4			12.0			16.3				10.9
Confl. Peds. (#/hr)	1		1	1		1			2	2		
Confl. Bikes (#/hr)			1			1						
Peak Hour Factor	0.85	0.85	0.85	0.83	0.83	0.83	0.90	0.90	0.90	0.89	0.89	0.89
Adj. Flow (vph)	311	718	0	0	783	188	249	283	102	287	0	763
Shared Lane Traffic (%)							15%					
Lane Group Flow (vph)	311	718	0	0	971	0	212	422	0	287	0	763
Enter Blocked Intersection	No	No	No	No	No	No	No	No	No	No	No	No
Lane Alignment	Left	Left	Right	Left	Left	Right	Left	Left	Right	Left	Left	Right
Median Width(ft)		24			24			24				24
Link Offset(ft)		0			0			0				0
Crosswalk Width(ft)		16			16			16				16
Two way Left Turn Lane												
Headway Factor	1.00	1.00	1.00	1.00	1.00	1.00	1.00	1.00	1.00	1.00	1.00	1.00
Turning Speed (mph)	15		9	15		9	15		9	15		9
Number of Detectors	1	2			2		1	2		1		1
Detector Template	Left	Thru			Thru		Left	Thru		Left		Right
Leading Detector (ft)	20	100			100		20	100		20		20
Trailing Detector (ft)	0	0			0		0	0		0		0
Detector 1 Position(ft)	0	0			0		0	0		0		0
Detector 1 Size(ft)	20	6			6		20	6		20		20
Detector 1 Type	Cl+Ex	Cl+Ex			Cl+Ex		Cl+Ex	Cl+Ex		Cl+Ex		Cl+Ex
Detector 1 Channel												
Detector 1 Extend (s)	0.0	0.0			0.0		0.0	0.0		0.0		0.0
Detector 1 Queue (s)	0.0	0.0			0.0		0.0	0.0		0.0		0.0
Detector 1 Delay (s)	0.0	0.0			0.0		0.0	0.0		0.0		0.0
Detector 2 Position(ft)		94			94			94				
Detector 2 Size(ft)		6			6			6				
Detector 2 Type		Cl+Ex			Cl+Ex			Cl+Ex				
Detector 2 Channel												
Detector 2 Extend (s)		0.0			0.0			0.0				

Lanes, Volumes, Timings

General Plan 2040 Conditions

10: US 101 NB Off Ramp/Lakewood Drive & Old Redwood Highway

Timing Plan: A.M. PEAK



Lane Group	EBL	EBT	EBR	WBL	WBT	WBR	NBL	NBT	NBR	SBL	SBT	SBR
Turn Type	Prot	NA			NA		Split	NA		Prot		pm+ov
Protected Phases	5	2			6		8	8		7		5
Permitted Phases												5 8
Detector Phase	5	2			6		8	8		7		5
Switch Phase												
Minimum Initial (s)	7.0	10.0			10.0		10.0	10.0		7.0		7.0
Minimum Split (s)	11.0	32.1			32.1		33.7	33.7		11.0		11.0
Total Split (s)	13.0	45.3			32.3		33.7	33.7		11.0		13.0
Total Split (%)	14.4%	50.3%			35.9%		37.4%	37.4%		12.2%		14.4%
Maximum Green (s)	9.0	40.2			27.2		29.0	29.0		7.0		9.0
Yellow Time (s)	3.0	4.1			4.1		3.7	3.7		3.0		3.0
All-Red Time (s)	1.0	1.0			1.0		1.0	1.0		1.0		1.0
Lost Time Adjust (s)	0.0	0.0			0.0		0.0	0.0		0.0		0.0
Total Lost Time (s)	4.0	5.1			5.1		4.7	4.7		4.0		4.0
Lead/Lag	Lead				Lag		Lag	Lag		Lead		Lead
Lead-Lag Optimize?	Yes				Yes		Yes	Yes		Yes		Yes
Vehicle Extension (s)	3.0	3.0			3.0		3.0	3.0		3.0		3.0
Recall Mode	None	Max			Max		None	None		None		None
Walk Time (s)		7.0			7.0		7.0	7.0				
Flash Don't Walk (s)		20.0			17.0		22.0	22.0				
Pedestrian Calls (#/hr)		0			0		0	0				
Act Effct Green (s)	9.0	40.4			27.3		17.0	17.0		7.0		30.8
Actuated g/C Ratio	0.11	0.52			0.35		0.22	0.22		0.09		0.39
v/c Ratio	0.79	0.75			0.80		0.61	0.57		0.93		0.99
Control Delay (s/veh)	50.6	22.6			29.4		35.0	27.0		75.7		46.6
Queue Delay	0.0	0.0			0.0		0.0	0.0		0.0		0.0
Total Delay (s/veh)	50.6	22.6			29.4		35.0	27.0		75.7		46.6
LOS	D	C			C		D	C		E		D
Approach Delay (s/veh)		31.1			29.4			29.7				54.6
Approach LOS		C			C			C				D

Intersection Summary

Area Type: Other  
 Cycle Length: 90  
 Actuated Cycle Length: 78.3  
 Natural Cycle: 90  
 Control Type: Actuated-Uncoordinated  
 Maximum v/c Ratio: 0.99  
 Intersection Signal Delay (s/veh): 37.1  
 Intersection LOS: D  
 Intersection Capacity Utilization 88.4%  
 ICU Level of Service E  
 Analysis Period (min) 15

Splits and Phases: 10: US 101 NB Off Ramp/Lakewood Drive & Old Redwood Highway



Lanes, Volumes, Timings  
 11: Old Redwood Highway & US 101 NB On Ramp

General Plan 2040 Conditions  
 Timing Plan: A.M. PEAK

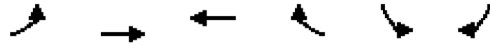

Lane Group	EBL	EBT	WBT	WBR	SBL	SBR
Lane Configurations						
Traffic Volume (vph)	0	874	1301	252	0	0
Future Volume (vph)	0	874	1301	252	0	0
Ideal Flow (vphpl)	1900	1900	1900	1900	1900	1900
Storage Length (ft)	245			0	0	0
Storage Lanes	1			0	0	0
Taper Length (ft)	50				25	
Lane Util. Factor	1.00	0.95	0.95	0.95	1.00	1.00
Ped Bike Factor						
Frt			0.976			
Flt Protected						
Satd. Flow (prot)	1863	3539	3454	0	0	0
Flt Permitted						
Satd. Flow (perm)	1863	3539	3454	0	0	0
Link Speed (mph)		35	35		30	
Link Distance (ft)		531	226		299	
Travel Time (s)		10.3	4.4		6.8	
Confl. Peds. (#/hr)	9					
Confl. Bikes (#/hr)				1		
Peak Hour Factor	0.81	0.81	0.89	0.89	0.25	0.25
Adj. Flow (vph)	0	1079	1462	283	0	0
Shared Lane Traffic (%)						
Lane Group Flow (vph)	0	1079	1745	0	0	0
Enter Blocked Intersection	No	No	No	No	No	No
Lane Alignment	Left	Left	Left	Right	Left	Right
Median Width(ft)		12	12		0	
Link Offset(ft)		0	0		0	
Crosswalk Width(ft)		16	16		16	
Two way Left Turn Lane						
Headway Factor	1.00	1.00	1.00	1.00	1.00	1.00
Turning Speed (mph)	15			9	15	9
Sign Control		Free	Free		Free	

Intersection Summary	
Area Type:	Other
Control Type:	Unsignalized
Intersection Capacity Utilization	102.0%
Analysis Period (min)	15
	ICU Level of Service G

Lanes, Volumes, Timings

General Plan 2040 Conditions

12: US 101 SB On Ramp/US 101 SB Off Ramp & Old Redwood Highway

Timing Plan: A.M. PEAK



Lane Group	EBL	EBT	EBR	WBL	WBT	WBR	NBL	NBT	NBR	SBL	SBT	SBR
Lane Configurations		↑↑	↗	↘	↑↑					↘	↔	
Traffic Volume (vph)	0	699	814	559	742	0	0	0	0	157	0	144
Future Volume (vph)	0	699	814	559	742	0	0	0	0	157	0	144
Ideal Flow (vphpl)	1900	1900	1900	1900	1900	1900	1900	1900	1900	1900	1900	1900
Storage Length (ft)	0		0	250		0	0		0	420		0
Storage Lanes	0		1	0		0	0		0	1		0
Taper Length (ft)	25			165			25			75		
Lane Util. Factor	1.00	0.95	1.00	1.00	0.95	1.00	1.00	1.00	1.00	0.95	0.95	1.00
Ped Bike Factor			0.98	1.00								
Frt			0.850								0.864	
Flt Protected				0.950						0.950	0.995	
Satd. Flow (prot)	0	3539	1583	1770	3539	0	0	0	0	1681	1521	0
Flt Permitted				0.950						0.950	0.995	
Satd. Flow (perm)	0	3539	1558	1768	3539	0	0	0	0	1681	1521	0
Right Turn on Red			Yes			Yes			Yes			Yes
Satd. Flow (RTOR)			361									178
Link Speed (mph)		35			35			30			30	
Link Distance (ft)		423			531			621			831	
Travel Time (s)		8.2			10.3			14.1			18.9	
Confl. Peds. (#/hr)	10		3	3		10						
Confl. Bikes (#/hr)			2									
Peak Hour Factor	0.92	0.92	0.92	0.89	0.89	0.89	0.25	0.25	0.25	0.81	0.81	0.81
Adj. Flow (vph)	0	760	885	628	834	0	0	0	0	194	0	178
Shared Lane Traffic (%)										10%		
Lane Group Flow (vph)	0	760	885	628	834	0	0	0	0	175	197	0
Enter Blocked Intersection	No	No	No	No	No	No	No	No	No	No	No	No
Lane Alignment	Left	Left	Right	Left	Left	Right	Left	Left	Right	Left	Left	Right
Median Width(ft)		24			24			12			12	
Link Offset(ft)		0			0			0			0	
Crosswalk Width(ft)		16			16			16			16	
Two way Left Turn Lane												
Headway Factor	1.00	1.00	1.00	1.00	1.00	1.00	1.00	1.00	1.00	1.00	1.00	1.00
Turning Speed (mph)	15		9	15		9	15		9	15		9
Number of Detectors		2	1	1	2					1	2	
Detector Template		Thru	Right	Left	Thru					Left	Thru	
Leading Detector (ft)		100	20	20	100					20	100	
Trailing Detector (ft)		0	0	0	0					0	0	
Detector 1 Position(ft)		0	0	0	0					0	0	
Detector 1 Size(ft)		6	20	20	6					20	6	
Detector 1 Type		Cl+Ex	Cl+Ex	Cl+Ex	Cl+Ex					Cl+Ex	Cl+Ex	
Detector 1 Channel												
Detector 1 Extend (s)		0.0	0.0	0.0	0.0					0.0	0.0	
Detector 1 Queue (s)		0.0	0.0	0.0	0.0					0.0	0.0	
Detector 1 Delay (s)		0.0	0.0	0.0	0.0					0.0	0.0	
Detector 2 Position(ft)		94			94							94
Detector 2 Size(ft)		6			6							6
Detector 2 Type		Cl+Ex			Cl+Ex							Cl+Ex
Detector 2 Channel												
Detector 2 Extend (s)		0.0			0.0							0.0

Lanes, Volumes, Timings

General Plan 2040 Conditions

12: US 101 SB On Ramp/US 101 SB Off Ramp & Old Redwood Highway

Timing Plan: A.M. PEAK



Lane Group	EBL	EBT	EBR	WBL	WBT	WBR	NBL	NBT	NBR	SBL	SBT	SBR
Turn Type		NA	Perm	Prot	NA					Perm	NA	
Protected Phases		6		5	2						8	
Permitted Phases			6							8		
Detector Phase		6	6	5	2					8	8	
Switch Phase												
Minimum Initial (s)		10.0	10.0	7.0	10.0					10.0	10.0	
Minimum Split (s)		32.1	32.1	11.0	38.1					14.7	14.7	
Total Split (s)		32.3	32.3	33.0	65.3					14.7	14.7	
Total Split (%)		40.4%	40.4%	41.3%	81.6%					18.4%	18.4%	
Maximum Green (s)		27.2	27.2	29.0	60.2					10.0	10.0	
Yellow Time (s)		4.1	4.1	3.0	4.1					3.7	3.7	
All-Red Time (s)		1.0	1.0	1.0	1.0					1.0	1.0	
Lost Time Adjust (s)		0.0	0.0	0.0	0.0					0.0	0.0	
Total Lost Time (s)		5.1	5.1	4.0	5.1					4.7	4.7	
Lead/Lag		Lag	Lag	Lead								
Lead-Lag Optimize?		Yes	Yes	Yes								
Vehicle Extension (s)		3.0	3.0	3.0	3.0					3.0	3.0	
Recall Mode		Max	Max	None	Max					None	None	
Walk Time (s)		7.0	7.0		7.0							
Flash Don't Walk (s)		20.0	20.0		25.0							
Pedestrian Calls (#/hr)		0	0		0							
Act Effct Green (s)		27.2	27.2	29.0	60.2					10.0	10.0	
Actuated g/C Ratio		0.34	0.34	0.36	0.75					0.13	0.13	
v/c Ratio		0.63	1.15	0.98	0.31					0.83	0.57	
Control Delay (s/veh)		25.1	101.9	58.5	3.6					67.4	14.4	
Queue Delay		0.0	0.0	0.0	0.0					0.0	0.0	
Total Delay (s/veh)		25.1	101.9	58.5	3.6					67.4	14.4	
LOS		C	F	E	A					E	B	
Approach Delay (s/veh)		66.4			27.1						39.3	
Approach LOS		E			C						D	

Intersection Summary

Area Type: Other

Cycle Length: 80

Actuated Cycle Length: 80

Natural Cycle: 110

Control Type: Actuated-Uncoordinated

Maximum v/c Ratio: 1.15

Intersection Signal Delay (s/veh): 47.0

Intersection LOS: D

Intersection Capacity Utilization 102.0%

ICU Level of Service G

Analysis Period (min) 15



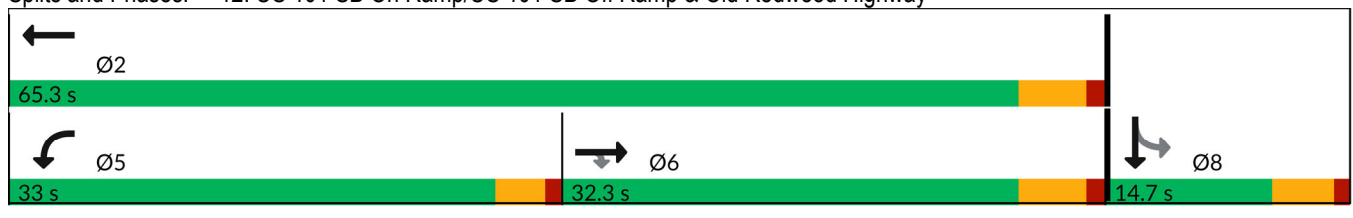



















Splits and Phases: 12: US 101 SB On Ramp/US 101 SB Off Ramp & Old Redwood Highway



Lanes, Volumes, Timings  
 1: Old Redwood Hwy & Shiloh Road

General Plan 2040 Conditions

Timing Plan: P.M. Peak

												
Lane Group	EBL	EBT	EBR	WBL	WBT	WBR	NBL	NBT	NBR	SBL	SBT	SBR
Lane Configurations												
Traffic Volume (vph)	317	125	572	44	139	31	598	557	44	43	536	265
Future Volume (vph)	317	125	572	44	139	31	598	557	44	43	536	265
Ideal Flow (vphpl)	1900	1900	1900	1900	1900	1900	1900	1900	1900	1900	1900	1900
Storage Length (ft)	375		140	0		50	200		98	130		93
Storage Lanes	1		1	0		1	1		1	1		1
Taper Length (ft)	50			25			60			93		
Lane Util. Factor	1.00	1.00	1.00	1.00	1.00	1.00	1.00	1.00	1.00	1.00	1.00	1.00
Ped Bike Factor	1.00					0.98	1.00		0.98			0.97
Frt			0.850			0.850			0.850			0.850
Flt Protected	0.950				0.988		0.950			0.950		
Satd. Flow (prot)	1770	1863	1583	0	1840	1583	1770	1863	1583	1770	1863	1583
Flt Permitted	0.950				0.988		0.950			0.950		
Satd. Flow (perm)	1767	1863	1583	0	1840	1549	1768	1863	1546	1770	1863	1542
Right Turn on Red			Yes			Yes			Yes			Yes
Satd. Flow (RTOR)			563			105			77			105
Link Speed (mph)		40			40			45				40
Link Distance (ft)		1789			608			748				775
Travel Time (s)		30.5			10.4			11.3				13.2
Confl. Peds. (#/hr)	1						1	1				1
Confl. Bikes (#/hr)									3			3
Peak Hour Factor	0.97	0.97	0.97	0.91	0.91	0.91	0.93	0.93	0.93	0.93	0.93	0.93
Adj. Flow (vph)	327	129	590	48	153	34	643	599	47	46	576	285
Shared Lane Traffic (%)												
Lane Group Flow (vph)	327	129	590	0	201	34	643	599	47	46	576	285
Enter Blocked Intersection	No	No	No	No	No	No	No	No	No	No	No	No
Lane Alignment	Left	Left	Right	Left	Left	Right	Left	Left	Right	Left	Left	Right
Median Width(ft)		12			12			12				12
Link Offset(ft)		0			0			0				0
Crosswalk Width(ft)		16			16			16				16
Two way Left Turn Lane												
Headway Factor	1.00	1.00	1.00	1.00	1.00	1.00	1.00	1.00	1.00	1.00	1.00	1.00
Turning Speed (mph)	15		9	15		9	15		9	15		9
Number of Detectors	1	2	1	1	2	1	1	2	1	1	2	1
Detector Template	Left	Thru	Right	Left	Thru	Right	Left	Thru	Right	Left	Thru	Right
Leading Detector (ft)	20	100	20	20	100	20	20	100	20	20	100	20
Trailing Detector (ft)	0	0	0	0	0	0	0	0	0	0	0	0
Detector 1 Position(ft)	0	0	0	0	0	0	0	0	0	0	0	0
Detector 1 Size(ft)	20	6	20	20	6	20	20	6	20	20	6	20
Detector 1 Type	Cl+Ex	Cl+Ex	Cl+Ex	Cl+Ex	Cl+Ex	Cl+Ex	Cl+Ex	Cl+Ex	Cl+Ex	Cl+Ex	Cl+Ex	Cl+Ex
Detector 1 Channel												
Detector 1 Extend (s)	0.0	0.0	0.0	0.0	0.0	0.0	0.0	0.0	0.0	0.0	0.0	0.0
Detector 1 Queue (s)	0.0	0.0	0.0	0.0	0.0	0.0	0.0	0.0	0.0	0.0	0.0	0.0
Detector 1 Delay (s)	0.0	0.0	0.0	0.0	0.0	0.0	0.0	0.0	0.0	0.0	0.0	0.0
Detector 2 Position(ft)		94			94			94				94
Detector 2 Size(ft)		6			6			6				6
Detector 2 Type		Cl+Ex			Cl+Ex			Cl+Ex				Cl+Ex
Detector 2 Channel												
Detector 2 Extend (s)		0.0			0.0			0.0				0.0



Lanes, Volumes, Timings  
1: Old Redwood Hwy & Shiloh Road

General Plan 2040 Conditions  
Timing Plan: P.M. Peak

Lane Group	EBL	EBT	EBR	WBL	WBT	WBR	NBL	NBT	NBR	SBL	SBT	SBR
Turn Type	Split	NA	Perm	Split	NA	Perm	Prot	NA	Perm	Prot	NA	Perm
Protected Phases	2	2		6	6		3	8		7	4	
Permitted Phases			2			6			8			4
Detector Phase	2	2	2	6	6	6	3	8	8	7	4	4
Switch Phase												
Minimum Initial (s)	5.0	5.0	5.0	5.0	5.0	5.0	5.0	5.0	5.0	5.0	5.0	5.0
Minimum Split (s)	34.5	34.5	34.5	42.5	42.5	42.5	8.5	46.5	46.5	8.5	39.5	39.5
Total Split (s)	35.0	35.0	35.0	42.5	42.5	42.5	18.0	48.0	48.0	9.5	39.5	39.5
Total Split (%)	25.9%	25.9%	25.9%	31.5%	31.5%	31.5%	13.3%	35.6%	35.6%	7.0%	29.3%	29.3%
Maximum Green (s)	30.5	30.5	30.5	38.0	38.0	38.0	14.5	43.5	43.5	6.0	35.0	35.0
Yellow Time (s)	3.5	3.5	3.5	3.5	3.5	3.5	3.0	3.5	3.5	3.0	3.5	3.5
All-Red Time (s)	1.0	1.0	1.0	1.0	1.0	1.0	0.5	1.0	1.0	0.5	1.0	1.0
Lost Time Adjust (s)	0.0	0.0	0.0		0.0	0.0	0.0	0.0	0.0	0.0	0.0	0.0
Total Lost Time (s)	4.5	4.5	4.5		4.5	4.5	3.5	4.5	4.5	3.5	4.5	4.5
Lead/Lag	Lead	Lead	Lead	Lag	Lag	Lag	Lead	Lag	Lag	Lead	Lag	Lag
Lead-Lag Optimize?	Yes	Yes	Yes	Yes	Yes	Yes	Yes	Yes	Yes	Yes	Yes	Yes
Vehicle Extension (s)	3.0	3.0	3.0	3.0	3.0	3.0	3.0	3.0	3.0	3.0	3.0	3.0
Recall Mode	None	None	None	None	None	None	None	None	None	None	None	None
Walk Time (s)	7.0	7.0	7.0	7.0	7.0	7.0		7.0	7.0		7.0	7.0
Flash Don't Walk (s)	23.0	23.0	23.0	31.0	31.0	31.0		35.0	35.0		28.0	28.0
Pedestrian Calls (#/hr)	0	0	0	0	0	0		0	0		0	0
Act Effct Green (s)	26.7	26.7	26.7		17.4	17.4	14.6	46.0	46.0	6.0	35.2	35.2
Actuated g/C Ratio	0.24	0.24	0.24		0.16	0.16	0.13	0.41	0.41	0.05	0.32	0.32
v/c Ratio	0.77	0.29	0.73		0.70	0.10	2.77	0.78	0.07	0.48	0.98	0.51
Control Delay (s/veh)	52.9	36.9	10.1		58.1	0.6	829.2	39.4	2.1	71.5	71.0	24.2
Queue Delay	0.0	0.0	0.0		0.0	0.0	0.0	0.0	0.0	0.0	0.0	0.0
Total Delay (s/veh)	52.9	36.9	10.1		58.1	0.6	829.2	39.4	2.1	71.5	71.0	24.2
LOS	D	D	B		E	A	F	D	A	E	E	C
Approach Delay (s/veh)		26.8			49.8			432.0			56.3	
Approach LOS		C			D			F			E	

Intersection Summary





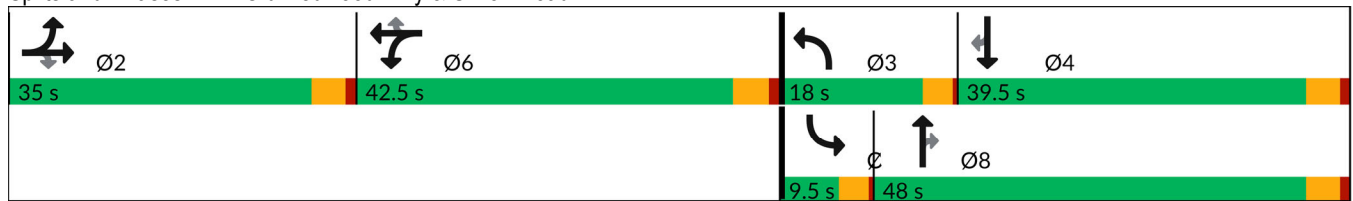



















Area Type: Other  
 Cycle Length: 135  
 Actuated Cycle Length: 111.1  
 Natural Cycle: 145  
 Control Type: Actuated-Uncoordinated  
 Maximum v/c Ratio: 2.77  
 Intersection Signal Delay (s/veh): 186.3  
 Intersection LOS: F  
 Intersection Capacity Utilization 104.0%  
 ICU Level of Service G  
 Analysis Period (min) 15

Splits and Phases: 1: Old Redwood Hwy & Shiloh Road



Lanes, Volumes, Timings  
2: Shiloh Road & Hembree Ln

General Plan 2040 Conditions  
Timing Plan: P.M. Peak

												
Lane Group	EBL	EBT	EBR	WBL	WBT	WBR	NBL	NBT	NBR	SBL	SBT	SBR
Lane Configurations	 			 	 						 	
Traffic Volume (vph)	661	811	69	110	774	118	111	21	128	174	11	526
Future Volume (vph)	661	811	69	110	774	118	111	21	128	174	11	526
Ideal Flow (vphpl)	1900	1900	1900	1900	1900	1900	1900	1900	1900	1900	1900	1900
Storage Length (ft)	0		0	100		130	0		0	0		0
Storage Lanes	2		0	1		1	1		0	0		1
Taper Length (ft)	25			50			25			25		
Lane Util. Factor	0.97	1.00	1.00	1.00	0.95	0.95	1.00	1.00	1.00	1.00	1.00	1.00
Ped Bike Factor	1.00				1.00							
Frt		0.989			0.980			0.871				0.850
Flt Protected	0.950			0.950			0.950				0.955	
Satd. Flow (prot)	3433	1842	0	1770	3462	0	1770	1622	0	0	1779	1583
Flt Permitted	0.950			0.950			0.950				0.955	
Satd. Flow (perm)	3431	1842	0	1770	3462	0	1770	1622	0	0	1779	1583
Right Turn on Red			Yes			Yes			Yes			Yes
Satd. Flow (RTOR)		8			25			128				85
Link Speed (mph)		40			40			30				35
Link Distance (ft)		302			1789			216				381
Travel Time (s)		5.1			30.5			4.9				7.4
Confl. Peds. (#/hr)	2						2					
Peak Hour Factor	0.94	0.94	1.00	1.00	0.87	0.87	1.00	1.00	1.00	0.95	1.00	0.95
Adj. Flow (vph)	703	863	69	110	890	136	111	21	128	183	11	554
Shared Lane Traffic (%)												
Lane Group Flow (vph)	703	932	0	110	1026	0	111	149	0	0	194	554
Enter Blocked Intersection	No	No	No	No	No	No	No	No	No	No	No	No
Lane Alignment	Left	Left	Right	Left	Left	Right	Left	Left	Right	Left	Left	Right
Median Width(ft)		24			24			12				12
Link Offset(ft)		0			0			0				0
Crosswalk Width(ft)		16			16			16				16
Two way Left Turn Lane												
Headway Factor	1.00	1.00	1.00	1.00	1.00	1.00	1.00	1.00	1.00	1.00	1.00	1.00
Turning Speed (mph)	15		60	60		9	60		60	15		9
Number of Detectors	1	2		1	2		1	2		1	2	1
Detector Template	Left	Thru		Left	Thru		Left	Thru		Left	Thru	Right
Leading Detector (ft)	20	100		20	100		20	100		20	100	20
Trailing Detector (ft)	0	0		0	0		0	0		0	0	0
Detector 1 Position(ft)	0	0		0	0		0	0		0	0	0
Detector 1 Size(ft)	20	6		20	6		20	6		20	6	20
Detector 1 Type	Cl+Ex	Cl+Ex		Cl+Ex	Cl+Ex		Cl+Ex	Cl+Ex		Cl+Ex	Cl+Ex	Cl+Ex
Detector 1 Channel												
Detector 1 Extend (s)	0.0	0.0		0.0	0.0		0.0	0.0		0.0	0.0	0.0
Detector 1 Queue (s)	0.0	0.0		0.0	0.0		0.0	0.0		0.0	0.0	0.0
Detector 1 Delay (s)	0.0	0.0		0.0	0.0		0.0	0.0		0.0	0.0	0.0
Detector 2 Position(ft)		94			94			94				94
Detector 2 Size(ft)		6			6			6				6
Detector 2 Type		Cl+Ex			Cl+Ex			Cl+Ex				Cl+Ex
Detector 2 Channel												
Detector 2 Extend (s)		0.0			0.0			0.0				0.0
Turn Type	Prot	NA		Prot	NA		Split	NA		Split	NA	pt+ov

Lanes, Volumes, Timings  
2: Shiloh Road & Hembree Ln

General Plan 2040 Conditions  
Timing Plan: P.M. Peak

Lane Group	EBL	EBT	EBR	WBL	WBT	WBR	NBL	NBT	NBR	SBL	SBT	SBR
Protected Phases	5	2		1	6		8	8		4	4	4 5
Permitted Phases												
Detector Phase	5	2		1	6		8	8		4	4	4 5
Switch Phase												
Minimum Initial (s)	3.0	5.0		5.0	5.0		5.0	5.0		5.0	5.0	
Minimum Split (s)	7.5	9.5		9.5	43.5		9.5	9.5		9.5	9.5	
Total Split (s)	21.0	57.0		9.5	45.5		9.5	9.5		14.0	14.0	
Total Split (%)	23.3%	63.3%		10.6%	50.6%		10.6%	10.6%		15.6%	15.6%	
Maximum Green (s)	17.0	53.0		5.5	41.5		5.5	5.5		10.0	10.0	
Yellow Time (s)	3.0	3.0		3.0	3.0		3.0	3.0		3.0	3.0	
All-Red Time (s)	1.0	1.0		1.0	1.0		1.0	1.0		1.0	1.0	
Lost Time Adjust (s)	0.0	0.0		0.0	0.0		0.0	0.0			0.0	
Total Lost Time (s)	4.0	4.0		4.0	4.0		4.0	4.0			4.0	
Lead/Lag	Lead	Lag		Lead	Lag							
Lead-Lag Optimize?	Yes	Yes		Yes	Yes							
Vehicle Extension (s)	3.0	3.0		3.0	3.0		3.0	3.0		3.0	3.0	
Recall Mode	None	None		None	None		None	None		None	None	
Walk Time (s)					7.0							
Flash Don't Walk (s)					32.0							
Pedestrian Calls (#/hr)					1							
Act Effct Green (s)	17.2	45.9		5.6	34.3		5.6	5.6		10.1	27.3	
Actuated g/C Ratio	0.21	0.55		0.07	0.41		0.07	0.07		0.12	0.33	
v/c Ratio	0.99	0.91		0.93	0.71		0.94	0.66		0.90	0.96	
Control Delay (s/veh)	68.9	31.2		111.9	22.5		113.9	26.1		81.0	52.7	
Queue Delay	0.0	0.6		0.0	0.0		0.0	0.0		0.0	0.0	
Total Delay (s/veh)	68.9	31.8		111.9	22.5		113.9	26.1		81.0	52.7	
LOS	E	C		F	C		F	C		F	D	
Approach Delay (s/veh)		47.7			31.1			63.6			60.0	
Approach LOS		D			C			E			E	

Intersection Summary

Area Type:	Other
Cycle Length:	90
Actuated Cycle Length:	83.3
Natural Cycle:	90
Control Type:	Actuated-Uncoordinated
Maximum v/c Ratio:	0.99
Intersection Signal Delay (s/veh):	46.3
Intersection LOS:	D
Intersection Capacity Utilization:	85.5%
ICU Level of Service:	E
Analysis Period (min):	15

Splits and Phases: 2: Shiloh Road & Hembree Ln



Lanes, Volumes, Timings  
3: US 101 NB Off-Ramp & Shiloh Road

General Plan 2040 Conditions  
Timing Plan: P.M. Peak

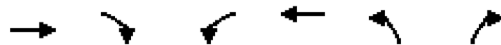

Lane Group	EBT	EBR	WBL	WBT	NBL	NBR
Lane Configurations	↑↑			↑	↘	↗↗
Traffic Volume (vph)	761	0	0	871	694	737
Future Volume (vph)	761	0	0	871	694	737
Ideal Flow (vphpl)	1900	1900	1900	1900	1900	1900
Storage Length (ft)		0	0		0	265
Storage Lanes		0	0		1	2
Taper Length (ft)			25		25	
Lane Util. Factor	0.95	1.00	1.00	1.00	1.00	0.88
Frt						0.850
Flt Protected					0.950	
Satd. Flow (prot)	3539	0	0	1863	1770	2787
Flt Permitted					0.950	
Satd. Flow (perm)	3539	0	0	1863	1770	2787
Right Turn on Red		Yes				Yes
Satd. Flow (RTOR)						185
Link Speed (mph)	40			40	30	
Link Distance (ft)	186			371	769	
Travel Time (s)	3.2			6.3	17.5	
Peak Hour Factor	0.94	0.94	0.97	0.97	0.90	0.90
Adj. Flow (vph)	810	0	0	898	771	819
Shared Lane Traffic (%)						
Lane Group Flow (vph)	810	0	0	898	771	819
Enter Blocked Intersection	No	No	No	No	No	No
Lane Alignment	Left	Right	Left	Left	Left	Right
Median Width(ft)	0			0	12	
Link Offset(ft)	0			0	0	
Crosswalk Width(ft)	16			16	16	
Two way Left Turn Lane						
Headway Factor	1.00	1.00	1.00	1.00	1.00	1.00
Turning Speed (mph)		9	15		15	9
Number of Detectors	2			2	1	1
Detector Template	Thru			Thru	Left	Right
Leading Detector (ft)	100			100	20	20
Trailing Detector (ft)	0			0	0	0
Detector 1 Position(ft)	0			0	0	0
Detector 1 Size(ft)	6			6	20	20
Detector 1 Type	Cl+Ex			Cl+Ex	Cl+Ex	Cl+Ex
Detector 1 Channel						
Detector 1 Extend (s)	0.0			0.0	0.0	0.0
Detector 1 Queue (s)	0.0			0.0	0.0	0.0
Detector 1 Delay (s)	0.0			0.0	0.0	0.0
Detector 2 Position(ft)	94			94		
Detector 2 Size(ft)	6			6		
Detector 2 Type	Cl+Ex			Cl+Ex		
Detector 2 Channel						
Detector 2 Extend (s)	0.0			0.0		
Turn Type	NA			NA	Prot	Perm
Protected Phases	2			6	8	
Permitted Phases						8

Lanes, Volumes, Timings  
 3: US 101 NB Off-Ramp & Shiloh Road

General Plan 2040 Conditions  
 Timing Plan: P.M. Peak



Lane Group	EBT	EBR	WBL	WBT	NBL	NBR
Detector Phase	2			6	8	8
Switch Phase						
Minimum Initial (s)	5.0			5.0	5.0	5.0
Minimum Split (s)	9.0			9.0	9.0	9.0
Total Split (s)	37.0			37.0	35.0	35.0
Total Split (%)	51.4%			51.4%	48.6%	48.6%
Maximum Green (s)	33.0			33.0	31.0	31.0
Yellow Time (s)	3.0			3.0	3.0	3.0
All-Red Time (s)	1.0			1.0	1.0	1.0
Lost Time Adjust (s)	0.0			0.0	0.0	0.0
Total Lost Time (s)	4.0			4.0	4.0	4.0
Lead/Lag						
Lead-Lag Optimize?						
Vehicle Extension (s)	3.0			3.0	3.0	3.0
Recall Mode	None			None	None	None
Act Effect Green (s)	33.0			33.0	31.0	31.0
Actuated g/C Ratio	0.46			0.46	0.43	0.43
v/c Ratio	0.50			1.05	1.01	0.63
Control Delay (s/veh)	15.0			67.9	58.8	14.6
Queue Delay	0.0			0.0	0.0	0.0
Total Delay (s/veh)	15.0			67.9	58.8	14.6
LOS	B			E	E	B
Approach Delay (s/veh)	15.0			67.9	36.1	
Approach LOS	B			E	D	

Intersection Summary

Area Type: Other  
 Cycle Length: 72  
 Actuated Cycle Length: 72  
 Natural Cycle: 90  
 Control Type: Actuated-Uncoordinated  
 Maximum v/c Ratio: 1.05  
 Intersection Signal Delay (s/veh): 39.6  
 Intersection LOS: D  
 Intersection Capacity Utilization 150.0%  
 ICU Level of Service H  
 Analysis Period (min) 15

Splits and Phases: 3: US 101 NB Off-Ramp & Shiloh Road

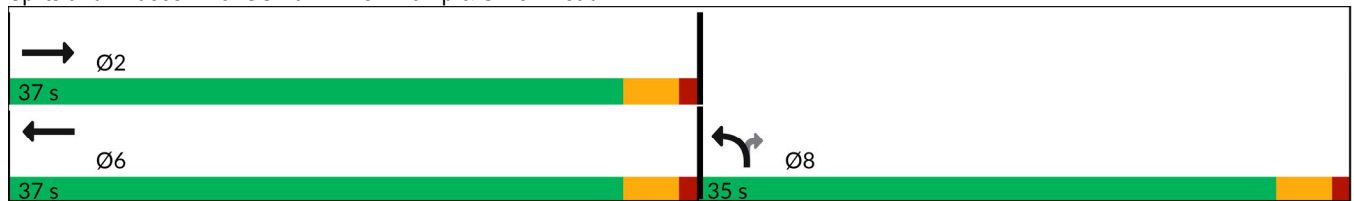

Lanes, Volumes, Timings  
4: Shiloh Road & US 101 SB Off-Ramp

General Plan 2040 Conditions  
Timing Plan: P.M. Peak

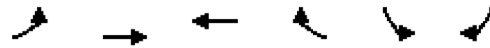

Lane Group	EBL	EBT	WBT	WBR	SBL	SBR
Lane Configurations		↑	↑		↓	↓
Traffic Volume (vph)	0	637	1059	0	322	94
Future Volume (vph)	0	637	1059	0	322	94
Ideal Flow (vphp)	1900	1900	1900	1900	1900	1900
Storage Length (ft)	0			0	0	275
Storage Lanes	0			0	1	1
Taper Length (ft)	25				25	
Lane Util. Factor	1.00	1.00	1.00	1.00	1.00	1.00
Ped Bike Factor						0.98
Frt						0.850
Flt Protected					0.950	
Satd. Flow (prot)	0	1863	1863	0	1770	1583
Flt Permitted					0.950	
Satd. Flow (perm)	0	1863	1863	0	1770	1548
Right Turn on Red				Yes		Yes
Satd. Flow (RTOR)						101
Link Speed (mph)		40	40		30	
Link Distance (ft)		225	306		486	
Travel Time (s)		3.8	5.2		11.0	
Confl. Peds. (#/hr)						1
Peak Hour Factor	0.89	0.89	0.96	0.96	0.93	0.93
Adj. Flow (vph)	0	716	1103	0	346	101
Shared Lane Traffic (%)						
Lane Group Flow (vph)	0	716	1103	0	346	101
Enter Blocked Intersection	No	No	No	No	No	No
Lane Alignment	Left	Left	Left	Right	Left	Right
Median Width(ft)		4	0		12	
Link Offset(ft)		0	0		0	
Crosswalk Width(ft)		16	16		16	
Two way Left Turn Lane						
Headway Factor	1.00	1.00	1.00	1.00	1.00	1.00
Turning Speed (mph)	15			9	15	9
Number of Detectors		2	2		1	1
Detector Template		Thru	Thru		Left	Right
Leading Detector (ft)		100	100		20	20
Trailing Detector (ft)		0	0		0	0
Detector 1 Position(ft)		0	0		0	0
Detector 1 Size(ft)		6	6		20	20
Detector 1 Type		Cl+Ex	Cl+Ex		Cl+Ex	Cl+Ex
Detector 1 Channel						
Detector 1 Extend (s)		0.0	0.0		0.0	0.0
Detector 1 Queue (s)		0.0	0.0		0.0	0.0
Detector 1 Delay (s)		0.0	0.0		0.0	0.0
Detector 2 Position(ft)		94	94			
Detector 2 Size(ft)		6	6			
Detector 2 Type		Cl+Ex	Cl+Ex			
Detector 2 Channel						
Detector 2 Extend (s)		0.0	0.0			
Turn Type		NA	NA		Perm	Perm

Lanes, Volumes, Timings  
4: Shiloh Road & US 101 SB Off-Ramp

General Plan 2040 Conditions  
Timing Plan: P.M. Peak

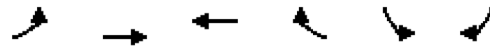

Lane Group	EBL	EBT	WBT	WBR	SBL	SBR
Protected Phases		2	6			
Permitted Phases					4	4
Detector Phase		2	6		4	4
Switch Phase						
Minimum Initial (s)		5.0	5.0		5.0	5.0
Minimum Split (s)		9.0	38.0		9.0	9.0
Total Split (s)		69.0	69.0		21.0	21.0
Total Split (%)		76.7%	76.7%		23.3%	23.3%
Maximum Green (s)		65.0	65.0		17.0	17.0
Yellow Time (s)		3.0	3.0		3.0	3.0
All-Red Time (s)		1.0	1.0		1.0	1.0
Lost Time Adjust (s)		0.0	0.0		0.0	0.0
Total Lost Time (s)		4.0	4.0		4.0	4.0
Lead/Lag						
Lead-Lag Optimize?						
Vehicle Extension (s)		3.0	3.0		3.0	3.0
Recall Mode		None	None		None	None
Walk Time (s)			7.0			
Flash Don't Walk (s)			27.0			
Pedestrian Calls (#/hr)			0			
Act Effct Green (s)		48.9	48.9		17.6	17.6
Actuated g/C Ratio		0.65	0.65		0.24	0.24
v/c Ratio		0.59	0.91		0.83	0.23
Control Delay (s/veh)		8.9	22.1		50.6	8.6
Queue Delay		0.0	0.0		0.0	0.0
Total Delay (s/veh)		8.9	22.1		50.6	8.6
LOS		A	C		D	A
Approach Delay (s/veh)		8.9	22.1		41.1	
Approach LOS		A	C		D	

Intersection Summary

Area Type:	Other
Cycle Length:	90
Actuated Cycle Length:	74.7
Natural Cycle:	65
Control Type:	Actuated-Uncoordinated
Maximum v/c Ratio:	0.91
Intersection Signal Delay (s/veh):	21.7
Intersection LOS:	C
Intersection Capacity Utilization:	150.2%
ICU Level of Service:	H
Analysis Period (min):	15

Splits and Phases: 4: Shiloh Road & US 101 SB Off-Ramp

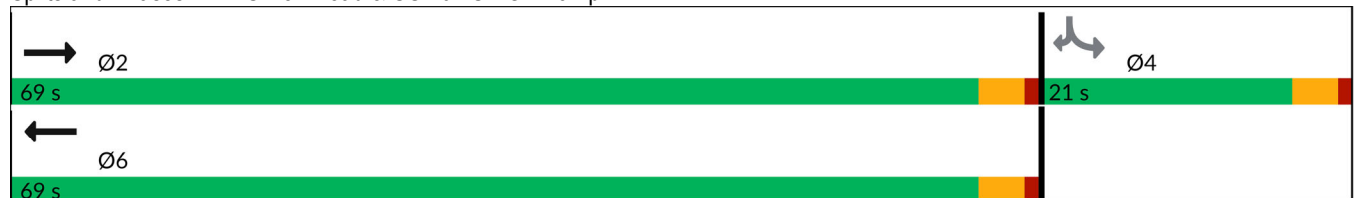

Lanes, Volumes, Timings  
5: Caletti Ave & Shiloh Road

General Plan 2040 Conditions  
Timing Plan: P.M. Peak

	→	↘	↙	←	↖	↗
Lane Group	EBT	EBR	WBL	WBT	NBL	NBR
Lane Configurations	↑↑		↘	↑	↘	↗
Traffic Volume (vph)	1179	16	105	1118	18	159
Future Volume (vph)	1179	16	105	1118	18	159
Ideal Flow (vphpl)	1900	1900	1900	1900	1900	1900
Storage Length (ft)		0	68		0	0
Storage Lanes		0	1		1	1
Taper Length (ft)			50		25	
Lane Util. Factor	0.95	0.95	1.00	1.00	1.00	1.00
Frt	0.998					0.850
Flt Protected			0.950		0.950	
Satd. Flow (prot)	3532	0	1770	1863	1770	1583
Flt Permitted			0.950		0.950	
Satd. Flow (perm)	3532	0	1770	1863	1770	1583
Link Speed (mph)	40			40	30	
Link Distance (ft)	1081			184	459	
Travel Time (s)	18.4			3.1	10.4	
Peak Hour Factor	0.89	0.89	0.92	0.92	0.89	0.89
Adj. Flow (vph)	1325	18	114	1215	20	179
Shared Lane Traffic (%)						
Lane Group Flow (vph)	1343	0	114	1215	20	179
Enter Blocked Intersection	No	No	No	No	No	No
Lane Alignment	Left	Right	Left	Left	Left	Right
Median Width(ft)	12			12	12	
Link Offset(ft)	0			0	0	
Crosswalk Width(ft)	16			16	16	
Two way Left Turn Lane						
Headway Factor	1.00	1.00	1.00	1.00	1.00	1.00
Turning Speed (mph)		9	15		15	9
Sign Control	Free			Free	Stop	
<b>Intersection Summary</b>						
Area Type:	Other					
Control Type:	Unsignalized					
Intersection Capacity Utilization	68.8%			ICU Level of Service C		
Analysis Period (min)	15					



Lanes, Volumes, Timings  
6: Conde Lane & Shiloh Road

General Plan 2040 Conditions  
Timing Plan: P.M. Peak

Lane Group	EBL	EBT	EBR	WBL	WBT	WBR	NBL	NBT	NBR	SBL	SBT	SBR
Lane Configurations												
Traffic Volume (vph)	77	702	0	9	722	372	4	2	16	387	4	65
Future Volume (vph)	77	702	0	9	722	372	4	2	16	387	4	65
Ideal Flow (vphpl)	1900	1900	1900	1900	1900	1900	1900	1900	1900	1900	1900	1900
Storage Length (ft)	90		0	127		0	0		0	0		40
Storage Lanes	1		0	1		0	0		0	0		1
Taper Length (ft)	70			40			25			25		
Lane Util. Factor	1.00	0.95	0.95	1.00	0.95	0.95	1.00	1.00	1.00	1.00	1.00	1.00
Ped Bike Factor	1.00				0.99							
Fr <sub>t</sub>					0.949			0.901				0.850
Fl <sub>t</sub> Protected	0.950			0.950				0.991			0.953	
Satd. Flow (prot)	1770	3539	0	1770	3334	0	0	1663	0	0	1775	1583
Fl <sub>t</sub> Permitted	0.950			0.950				0.991			0.953	
Satd. Flow (perm)	1768	3539	0	1770	3334	0	0	1663	0	0	1775	1583
Right Turn on Red			Yes			Yes			Yes			No
Satd. Flow (RTOR)					95			25				
Link Speed (mph)		40			40			30				35
Link Distance (ft)		815			1081			418				522
Travel Time (s)		13.9			18.4			9.5				10.2
Confl. Peds. (#/hr)	1						1					
Peak Hour Factor	0.88	0.88	0.88	0.80	0.80	0.80	0.63	0.63	0.63	0.88	0.88	0.88
Adj. Flow (vph)	88	798	0	11	903	465	6	3	25	440	5	74
Shared Lane Traffic (%)												
Lane Group Flow (vph)	88	798	0	11	1368	0	0	34	0	0	445	74
Enter Blocked Intersection	No	No	No	No	No	No	No	No	No	No	No	No
Lane Alignment	Left	Left	Right	Left	Left	Right	Left	Left	Right	Left	Left	Right
Median Width(ft)		12			12			0				0
Link Offset(ft)		0			0			0				0
Crosswalk Width(ft)		16			16			16				16
Two way Left Turn Lane												
Headway Factor	1.00	1.00	1.00	1.00	1.00	1.00	1.00	1.00	1.00	1.00	1.00	1.00
Turning Speed (mph)	15		9	15		9	15		9	15		9
Number of Detectors	1	2		1	2		1	2		1	1	1
Detector Template	Left	Thru		Left	Thru		Left	Thru		Left	Thru	Right
Leading Detector (ft)	20	100		20	100		20	100		20	30	20
Trailing Detector (ft)	0	0		0	0		0	0		0	0	0
Detector 1 Position(ft)	0	0		0	0		0	0		0	0	0
Detector 1 Size(ft)	20	6		20	6		20	6		20	30	20
Detector 1 Type	Cl+Ex	Cl+Ex		Cl+Ex	Cl+Ex		Cl+Ex	Cl+Ex		Cl+Ex	Cl+Ex	Cl+Ex
Detector 1 Channel												
Detector 1 Extend (s)	0.0	0.0		0.0	0.0		0.0	0.0		0.0	0.0	0.0
Detector 1 Queue (s)	0.0	0.0		0.0	0.0		0.0	0.0		0.0	0.0	0.0
Detector 1 Delay (s)	0.0	0.0		0.0	0.0		0.0	0.0		0.0	0.0	0.0
Detector 2 Position(ft)		94			94			94				
Detector 2 Size(ft)		6			6			6				
Detector 2 Type		Cl+Ex			Cl+Ex			Cl+Ex				
Detector 2 Channel												
Detector 2 Extend (s)		0.0			0.0			0.0				
Turn Type	Prot	NA		Prot	NA		Split	NA		Split	NA	custom

Lanes, Volumes, Timings  
6: Conde Lane & Shiloh Road

General Plan 2040 Conditions  
Timing Plan: P.M. Peak

Lane Group	EBL	EBT	EBR	WBL	WBT	WBR	NBL	NBT	NBR	SBL	SBT	SBR
Protected Phases	5	2		1	6		7	7		4	4	
Permitted Phases												6
Detector Phase	5	2		1	6		7	7		4	4	6
Switch Phase												
Minimum Initial (s)	8.0	8.0		8.0	8.0		10.0	10.0		11.0	11.0	8.0
Minimum Split (s)	12.0	46.0		12.0	12.0		37.0	37.0		15.0	15.0	12.0
Total Split (s)	13.0	46.0		12.0	45.0		37.0	37.0		15.0	15.0	45.0
Total Split (%)	11.8%	41.8%		10.9%	40.9%		33.6%	33.6%		13.6%	13.6%	40.9%
Maximum Green (s)	9.0	42.0		8.0	41.0		33.0	33.0		11.0	11.0	41.0
Yellow Time (s)	3.0	3.0		3.0	3.0		3.0	3.0		3.0	3.0	3.0
All-Red Time (s)	1.0	1.0		1.0	1.0		1.0	1.0		1.0	1.0	1.0
Lost Time Adjust (s)	0.0	0.0		0.0	0.0		0.0	0.0		0.0	0.0	0.0
Total Lost Time (s)	4.0	4.0		4.0	4.0		4.0	4.0		4.0	4.0	4.0
Lead/Lag	Lead	Lag		Lead	Lag							Lag
Lead-Lag Optimize?	Yes	Yes		Yes	Yes							Yes
Vehicle Extension (s)	3.0	3.0		3.0	3.0		3.0	3.0		3.0	3.0	3.0
Recall Mode	None	None		None	None		None	None		None	None	None
Walk Time (s)		7.0					7.0	7.0				
Flash Don't Walk (s)		35.0					26.0	26.0				
Pedestrian Calls (#/hr)		0					0	0				
Act Effct Green (s)	8.7	49.4		8.2	41.9		10.2	10.2		11.2	11.2	41.9
Actuated g/C Ratio	0.11	0.63		0.10	0.53		0.13	0.13		0.14	0.14	0.53
v/c Ratio	0.45	0.36		0.06	0.75		0.14	0.14		1.75	1.75	0.09
Control Delay (s/veh)	44.0	9.3		37.1	19.0		19.5	19.5		381.4	381.4	12.6
Queue Delay	0.0	0.0		0.0	0.0		0.0	0.0		0.0	0.0	0.0
Total Delay (s/veh)	44.0	9.3		37.1	19.0		19.5	19.5		381.4	381.4	12.6
LOS	D	A		D	B		B	B		F	F	B
Approach Delay (s/veh)		12.7			19.2		19.5	19.5		328.8	328.8	
Approach LOS		B			B		B	B		F	F	

Intersection Summary

















Area Type:	Other
Cycle Length:	110
Actuated Cycle Length:	78.6
Natural Cycle:	150
Control Type:	Actuated-Uncoordinated
Maximum v/c Ratio:	1.75
Intersection Signal Delay (s/veh):	74.2
Intersection LOS:	E
Intersection Capacity Utilization:	76.9%
ICU Level of Service:	D
Analysis Period (min):	15

Splits and Phases: 6: Conde Lane & Shiloh Road





















Lanes, Volumes, Timings  
7: Entrance 1/Gridley Drive & Shiloh Road

General Plan 2040 Conditions  
Timing Plan: P.M. Peak

												
Lane Group	EBL	EBT	EBR	WBL	WBT	WBR	NBL	NBT	NBR	SBL	SBT	SBR
Lane Configurations												
Traffic Volume (vph)	25	152	0	0	185	0	0	0	0	0	0	21
Future Volume (vph)	25	152	0	0	185	0	0	0	0	0	0	21
Ideal Flow (vphpl)	1900	1900	1900	1900	1900	1900	1900	1900	1900	1900	1900	1900
Lane Util. Factor	1.00	1.00	1.00	1.00	1.00	1.00	1.00	1.00	1.00	1.00	1.00	1.00
Ped Bike Factor												
Frt												0.865
Flt Protected	0.993											
Satd. Flow (prot)	0	1850	0	0	1863	0	1863	1863	0	0	1611	0
Flt Permitted	0.993											
Satd. Flow (perm)	0	1850	0	0	1863	0	1863	1863	0	0	1611	0
Link Speed (mph)	40		40				30			30		
Link Distance (ft)	608		2146				248			715		
Travel Time (s)	10.4		36.6				5.6			16.3		
Confl. Peds. (#/hr)	1											
Confl. Bikes (#/hr)	1											
Peak Hour Factor	0.94	0.94	0.94	0.69	0.69	0.69	1.00	1.00	1.00	0.58	0.58	0.58
Adj. Flow (vph)	27	162	0	0	268	0	0	0	0	0	0	36
Shared Lane Traffic (%)												
Lane Group Flow (vph)	0	189	0	0	268	0	0	0	0	0	36	0
Enter Blocked Intersection	No	No	No	No	No	No	No	No	No	No	No	No
Lane Alignment	Left	Left	Right	Left	Left	Right	Left	Left	Right	Left	Left	Right
Median Width(ft)	0		0				12			12		
Link Offset(ft)	0		0				0			0		
Crosswalk Width(ft)	16		16				16			16		
Two way Left Turn Lane												
Headway Factor	1.00	1.00	1.00	1.00	1.00	1.00	1.00	1.00	1.00	1.00	1.00	1.00
Turning Speed (mph)	15		9		15		9		15		9	
Sign Control	Free		Free				Stop			Stop		
<b>Intersection Summary</b>												
Area Type:	Other											
Control Type:	Unsignalized											
Intersection Capacity Utilization	32.5%						ICU Level of Service A					
Analysis Period (min)	15											











Lanes, Volumes, Timings  
8: Old Redwood Hwy & Entrance 1

General Plan 2040 Conditions  
Timing Plan: P.M. Peak

												
Lane Group	EBL	EBT	EBR	WBL	WBT	WBR	NBL	NBT	NBR	SBL	SBT	SBR
Lane Configurations												
Traffic Volume (vph)	4	0	0	0	0	0	0	1195	0	0	1152	0
Future Volume (vph)	4	0	0	0	0	0	0	1195	0	0	1152	0
Ideal Flow (vphp)	1900	1900	1900	1900	1900	1900	1900	1900	1900	1900	1900	1900
Storage Length (ft)	0		0	0		0	0		0	50		0
Storage Lanes	0		0	1		0	0		0	1		0
Taper Length (ft)	25			25			25			25		
Lane Util. Factor	1.00	1.00	1.00	1.00	1.00	1.00	1.00	1.00	1.00	1.00	1.00	1.00
Ped Bike Factor												
Fr <sub>t</sub>												
Fl <sub>t</sub> Protected		0.950										
Satd. Flow (prot)	0	1770	0	1863	1863	0	0	1863	0	1863	1863	0
Fl <sub>t</sub> Permitted		0.950										
Satd. Flow (perm)	0	1770	0	1863	1863	0	0	1863	0	1863	1863	0
Link Speed (mph)		30			30			45			45	
Link Distance (ft)		98			385			520			748	
Travel Time (s)		2.2			8.8			7.9			11.3	
Confl. Bikes (#/hr)									3			5
Peak Hour Factor	0.38	0.38	0.38	1.00	1.00	1.00	0.91	0.91	0.91	0.94	0.94	0.94
Adj. Flow (vph)	11	0	0	0	0	0	0	1313	0	0	1226	0
Shared Lane Traffic (%)												
Lane Group Flow (vph)	0	11	0	0	0	0	0	1313	0	0	1226	0
Enter Blocked Intersection	No	No	No	No	No	No	No	No	No	No	No	No
Lane Alignment	Left	Left	Right	Left	Left	Right	Left	Left	Right	Left	Left	Right
Median Width(ft)		12			12			12			12	
Link Offset(ft)		0			0			0			0	
Crosswalk Width(ft)		16			16			16			16	
Two way Left Turn Lane												
Headway Factor	1.00	1.00	1.00	1.00	1.00	1.00	1.00	1.00	1.00	1.00	1.00	1.00
Turning Speed (mph)	15		9	15		9	15		9	15		9
Sign Control		Stop			Stop			Free			Free	
<b>Intersection Summary</b>												
Area Type:	Other											
Control Type:	Unsignalized											
Intersection Capacity Utilization	72.9%						ICU Level of Service C					
Analysis Period (min)	15											

Lanes, Volumes, Timings  
9: Entrance 2 & Shiloh Road

General Plan 2040 Conditions  
Timing Plan: P.M. Peak

						
Lane Group	EBT	EBR	WBL	WBT	NBL	NBR
Lane Configurations						
Traffic Volume (vph)	120	0	0	164	0	0
Future Volume (vph)	120	0	0	164	0	0
Ideal Flow (vphpl)	1900	1900	1900	1900	1900	1900
Lane Util. Factor	1.00	1.00	1.00	1.00	1.00	1.00
<b>Fr</b>						
<b>Flt Protected</b>						
Satd. Flow (prot)	1863	0	0	1863	1863	1863
<b>Flt Permitted</b>						
Satd. Flow (perm)	1863	0	0	1863	1863	1863
Link Speed (mph)	40			40	30	
Link Distance (ft)	2146			134	402	
Travel Time (s)	36.6			2.3	9.1	
Peak Hour Factor	0.92	0.92	0.68	0.68	1.00	1.00
Adj. Flow (vph)	130	0	0	241	0	0
<b>Shared Lane Traffic (%)</b>						
Lane Group Flow (vph)	130	0	0	241	0	0
Enter Blocked Intersection	No	No	No	No	No	No
Lane Alignment	Left	Right	Left	Left	Left	Right
Median Width(ft)	0			0	12	
Link Offset(ft)	0			0	0	
Crosswalk Width(ft)	16			16	16	
<b>Two way Left Turn Lane</b>						
Headway Factor	1.00	1.00	1.00	1.00	1.00	1.00
Turning Speed (mph)		9	15		15	9
Sign Control	Free			Free	Stop	
<b>Intersection Summary</b>						
Area Type:	Other					
Control Type:	Unsignalized					
Intersection Capacity Utilization	12.0%			ICU Level of Service A		
Analysis Period (min)	15					

Lanes, Volumes, Timings

General Plan 2040 Conditions

10: US 101 NB Off Ramp/Lakewood Drive & Old Redwood Highway

Timing Plan: P.M. Peak



Lane Group	EBL	EBT	EBR	WBL	WBT	WBR	NBL	NBT	NBR	SBL	SBT	SBR
Lane Configurations												
Traffic Volume (vph)	309	672	0	0	715	270	528	539	303	386	0	618
Future Volume (vph)	309	672	0	0	715	270	528	539	303	386	0	618
Ideal Flow (vphpl)	1900	1900	1900	1900	1900	1900	1900	1900	1900	1900	1900	1900
Storage Length (ft)	155		0	0		0	270		150	120		0
Storage Lanes	1		0	0		0	1		1	1		1
Taper Length (ft)	50			25			165			75		
Lane Util. Factor	0.97	1.00	1.00	1.00	0.95	0.95	0.91	0.91	0.95	0.97	1.00	1.00
Ped Bike Factor	1.00				0.99			0.99		1.00		
Flt					0.959			0.950				0.850
Flt Protected	0.950						0.950	0.996		0.950		
Satd. Flow (prot)	3433	1863	0	0	3374	0	1610	3187	0	3433	0	1583
Flt Permitted	0.950						0.950	0.996		0.950		
Satd. Flow (perm)	3429	1863	0	0	3374	0	1610	3187	0	3422	0	1583
Right Turn on Red			Yes			Yes			Yes			Yes
Satd. Flow (RTOR)					62			90				248
Link Speed (mph)		35			35			30				30
Link Distance (ft)		226			617			716				478
Travel Time (s)		4.4			12.0			16.3				10.9
Confl. Peds. (#/hr)	3		1	1		3			8	8		
Confl. Bikes (#/hr)			2			9						
Peak Hour Factor	0.87	0.87	0.87	0.91	0.91	0.91	0.92	0.92	0.92	0.96	0.96	0.96
Adj. Flow (vph)	355	772	0	0	786	297	574	586	329	402	0	644
Shared Lane Traffic (%)							13%					
Lane Group Flow (vph)	355	772	0	0	1083	0	499	990	0	402	0	644
Enter Blocked Intersection	No	No	No	No	No	No	No	No	No	No	No	No
Lane Alignment	Left	Left	Right	Left	Left	Right	Left	Left	Right	Left	Left	Right
Median Width(ft)		24			24			24				24
Link Offset(ft)		0			0			0				0
Crosswalk Width(ft)		16			16			16				16
Two way Left Turn Lane												
Headway Factor	1.00	1.00	1.00	1.00	1.00	1.00	1.00	1.00	1.00	1.00	1.00	1.00
Turning Speed (mph)	15		9	15		9	15		9	15		9
Number of Detectors	1	2			2		1	2		1		1
Detector Template	Left	Thru			Thru		Left	Thru		Left		Right
Leading Detector (ft)	20	100			100		20	100		20		20
Trailing Detector (ft)	0	0			0		0	0		0		0
Detector 1 Position(ft)	0	0			0		0	0		0		0
Detector 1 Size(ft)	20	6			6		20	6		20		20
Detector 1 Type	Cl+Ex	Cl+Ex			Cl+Ex		Cl+Ex	Cl+Ex		Cl+Ex		Cl+Ex
Detector 1 Channel												
Detector 1 Extend (s)	0.0	0.0			0.0		0.0	0.0		0.0		0.0
Detector 1 Queue (s)	0.0	0.0			0.0		0.0	0.0		0.0		0.0
Detector 1 Delay (s)	0.0	0.0			0.0		0.0	0.0		0.0		0.0
Detector 2 Position(ft)		94			94			94				
Detector 2 Size(ft)		6			6			6				
Detector 2 Type		Cl+Ex			Cl+Ex			Cl+Ex				
Detector 2 Channel												
Detector 2 Extend (s)		0.0			0.0			0.0				

Lanes, Volumes, Timings

General Plan 2040 Conditions

10: US 101 NB Off Ramp/Lakewood Drive & Old Redwood Highway

Timing Plan: P.M. Peak



Lane Group	EBL	EBT	EBR	WBL	WBT	WBR	NBL	NBT	NBR	SBL	SBT	SBR
Turn Type	Prot	NA			NA		Split	NA		Prot		pm+ov
Protected Phases	5	2			6		8	8		7		5
Permitted Phases												5 8
Detector Phase	5	2			6		8	8		7		5
Switch Phase												
Minimum Initial (s)	7.0	10.0			10.0		10.0	10.0		7.0		7.0
Minimum Split (s)	11.0	32.1			32.1		33.7	33.7		11.0		11.0
Total Split (s)	13.0	45.3			32.3		33.7	33.7		11.0		13.0
Total Split (%)	14.4%	50.3%			35.9%		37.4%	37.4%		12.2%		14.4%
Maximum Green (s)	9.0	40.2			27.2		29.0	29.0		7.0		9.0
Yellow Time (s)	3.0	4.1			4.1		3.7	3.7		3.0		3.0
All-Red Time (s)	1.0	1.0			1.0		1.0	1.0		1.0		1.0
Lost Time Adjust (s)	0.0	0.0			0.0		0.0	0.0		0.0		0.0
Total Lost Time (s)	4.0	5.1			5.1		4.7	4.7		4.0		4.0
Lead/Lag	Lead				Lag		Lag	Lag		Lead		Lead
Lead-Lag Optimize?	Yes				Yes		Yes	Yes		Yes		Yes
Vehicle Extension (s)	3.0	3.0			3.0		3.0	3.0		3.0		3.0
Recall Mode	None	Max			Max		None	None		None		None
Walk Time (s)		7.0			7.0		7.0	7.0				
Flash Don't Walk (s)		20.0			17.0		22.0	22.0				
Pedestrian Calls (#/hr)		0			0		0	0				
Act Effct Green (s)	9.0	40.2			27.2		29.0	29.0		7.0		42.7
Actuated g/C Ratio	0.10	0.45			0.30		0.32	0.32		0.08		0.47
v/c Ratio	1.03	0.93			1.02		0.96	0.91		1.51		0.73
Control Delay (s/veh)	99.4	43.0			63.4		63.3	40.3		277.9		17.0
Queue Delay	0.0	0.0			0.0		0.0	0.0		0.0		0.0
Total Delay (s/veh)	99.4	43.0			63.4		63.3	40.3		277.9		17.0
LOS	F	D			E		E	D		F		B
Approach Delay (s/veh)		60.8			63.4			48.0				117.3
Approach LOS		E			E			D				F

Intersection Summary

Area Type: Other  
 Cycle Length: 90  
 Actuated Cycle Length: 90  
 Natural Cycle: 100  
 Control Type: Actuated-Uncoordinated  
 Maximum v/c Ratio: 1.51  
 Intersection Signal Delay (s/veh): 69.8  
 Intersection LOS: E  
 Intersection Capacity Utilization 105.1%  
 ICU Level of Service G  
 Analysis Period (min) 15

Splits and Phases: 10: US 101 NB Off Ramp/Lakewood Drive & Old Redwood Highway

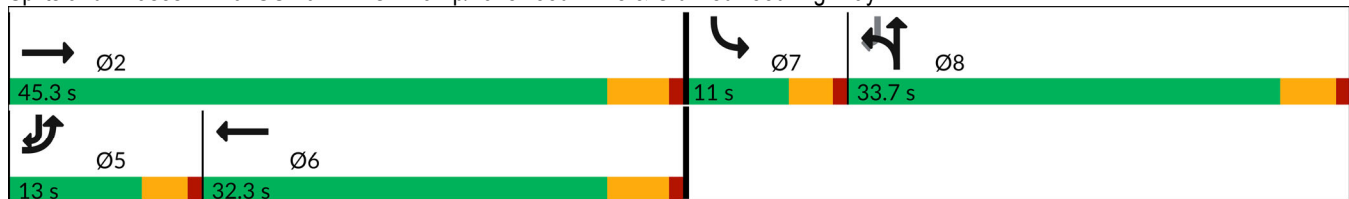

Lanes, Volumes, Timings  
 11: Old Redwood Highway & US 101 NB On Ramp

General Plan 2040 Conditions  
 Timing Plan: P.M. Peak

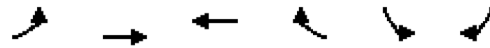

Lane Group	EBL	EBT	WBT	WBR	SBL	SBR
Lane Configurations						
Traffic Volume (vph)	0	981	1564	297	0	0
Future Volume (vph)	0	981	1564	297	0	0
Ideal Flow (vphpl)	1900	1900	1900	1900	1900	1900
Storage Length (ft)	245			0	0	0
Storage Lanes	1			0	0	0
Taper Length (ft)	50				25	
Lane Util. Factor	1.00	0.95	0.95	0.95	1.00	1.00
Ped Bike Factor						
Frt			0.976			
Flt Protected						
Satd. Flow (prot)	1863	3539	3454	0	0	0
Flt Permitted						
Satd. Flow (perm)	1863	3539	3454	0	0	0
Link Speed (mph)		35	35		30	
Link Distance (ft)		531	226		299	
Travel Time (s)		10.3	4.4		6.8	
Confl. Peds. (#/hr)	17			17		
Confl. Bikes (#/hr)				8		
Peak Hour Factor	0.85	0.85	0.91	0.91	0.25	0.25
Adj. Flow (vph)	0	1154	1719	326	0	0
Shared Lane Traffic (%)						
Lane Group Flow (vph)	0	1154	2045	0	0	0
Enter Blocked Intersection	No	No	No	No	No	No
Lane Alignment	Left	Left	Left	Right	Left	Right
Median Width(ft)		12	12		0	
Link Offset(ft)		0	0		0	
Crosswalk Width(ft)		16	16		16	
Two way Left Turn Lane						
Headway Factor	1.00	1.00	1.00	1.00	1.00	1.00
Turning Speed (mph)	15			9	15	9
Sign Control		Free	Free		Free	

Intersection Summary	
Area Type:	Other
Control Type:	Unsignalized
Intersection Capacity Utilization	82.4%
Analysis Period (min)	15
	ICU Level of Service E



Lanes, Volumes, Timings

General Plan 2040 Conditions

12: US 101 SB On Ramp/US 101 SB Off Ramp & Old Redwood Highway

Timing Plan: P.M. Peak



Lane Group	EBL	EBT	EBR	WBL	WBT	WBR	NBL	NBT	NBR	SBL	SBT	SBR
Lane Configurations		↑↑	↗	↘	↑↑					↘	↔	
Traffic Volume (vph)	0	612	501	443	1121	0	0	0	0	301	2	221
Future Volume (vph)	0	612	501	443	1121	0	0	0	0	301	2	221
Ideal Flow (vphpl)	1900	1900	1900	1900	1900	1900	1900	1900	1900	1900	1900	1900
Storage Length (ft)	0		0	250		0	0		0	420		0
Storage Lanes	0		1	0		0	0		0	1		0
Taper Length (ft)	25			165			25			75		
Lane Util. Factor	1.00	0.95	1.00	1.00	0.95	1.00	1.00	1.00	1.00	0.95	0.95	1.00
Ped Bike Factor			0.98	1.00								
Frt			0.850								0.869	
Flt Protected				0.950						0.950	0.994	
Satd. Flow (prot)	0	3539	1583	1770	3539	0	0	0	0	1681	1529	0
Flt Permitted				0.950						0.950	0.994	
Satd. Flow (perm)	0	3539	1558	1768	3539	0	0	0	0	1681	1529	0
Right Turn on Red			Yes			Yes			Yes			Yes
Satd. Flow (RTOR)			443								98	
Link Speed (mph)		35			35			30			30	
Link Distance (ft)		423			531			621			831	
Travel Time (s)		8.2			10.3			14.1			18.9	
Confl. Peds. (#/hr)	19		2	2		18						
Confl. Bikes (#/hr)			4			2						
Peak Hour Factor	0.94	0.94	0.94	0.89	0.89	0.89	0.25	0.25	0.25	0.83	0.83	0.83
Adj. Flow (vph)	0	651	533	498	1260	0	0	0	0	363	2	266
Shared Lane Traffic (%)										10%		
Lane Group Flow (vph)	0	651	533	498	1260	0	0	0	0	327	304	0
Enter Blocked Intersection	No	No	No	No	No	No	No	No	No	No	No	No
Lane Alignment	Left	Left	Right	Left	Left	Right	Left	Left	Right	Left	Left	Right
Median Width(ft)		24			24			12			12	
Link Offset(ft)		0			0			0			0	
Crosswalk Width(ft)		16			16			16			16	
Two way Left Turn Lane												
Headway Factor	1.00	1.00	1.00	1.00	1.00	1.00	1.00	1.00	1.00	1.00	1.00	1.00
Turning Speed (mph)	15		9	15		9	15		9	15		9
Number of Detectors		2	1	1	2					1	2	
Detector Template		Thru	Right	Left	Thru					Left	Thru	
Leading Detector (ft)		100	20	20	100					20	100	
Trailing Detector (ft)		0	0	0	0					0	0	
Detector 1 Position(ft)		0	0	0	0					0	0	
Detector 1 Size(ft)		6	20	20	6					20	6	
Detector 1 Type		Cl+Ex	Cl+Ex	Cl+Ex	Cl+Ex					Cl+Ex	Cl+Ex	
Detector 1 Channel												
Detector 1 Extend (s)		0.0	0.0	0.0	0.0					0.0	0.0	
Detector 1 Queue (s)		0.0	0.0	0.0	0.0					0.0	0.0	
Detector 1 Delay (s)		0.0	0.0	0.0	0.0					0.0	0.0	
Detector 2 Position(ft)		94			94							94
Detector 2 Size(ft)		6			6							6
Detector 2 Type		Cl+Ex			Cl+Ex							Cl+Ex
Detector 2 Channel												
Detector 2 Extend (s)		0.0			0.0							0.0

Lanes, Volumes, Timings

General Plan 2040 Conditions

12: US 101 SB On Ramp/US 101 SB Off Ramp & Old Redwood Highway

Timing Plan: P.M. Peak



Lane Group	EBL	EBT	EBR	WBL	WBT	WBR	NBL	NBT	NBR	SBL	SBT	SBR
Turn Type		NA	Perm	Prot	NA					Perm	NA	
Protected Phases		6		5	2						8	
Permitted Phases			6							8		
Detector Phase		6	6	5	2					8	8	
Switch Phase												
Minimum Initial (s)		10.0	10.0	7.0	10.0					10.0	10.0	
Minimum Split (s)		32.1	32.1	11.0	38.1					14.7	14.7	
Total Split (s)		33.0	33.0	22.0	55.0					15.0	15.0	
Total Split (%)		47.1%	47.1%	31.4%	78.6%					21.4%	21.4%	
Maximum Green (s)		27.9	27.9	18.0	49.9					10.3	10.3	
Yellow Time (s)		4.1	4.1	3.0	4.1					3.7	3.7	
All-Red Time (s)		1.0	1.0	1.0	1.0					1.0	1.0	
Lost Time Adjust (s)		0.0	0.0	0.0	0.0					0.0	0.0	
Total Lost Time (s)		5.1	5.1	4.0	5.1					4.7	4.7	
Lead/Lag		Lag	Lag	Lead								
Lead-Lag Optimize?		Yes	Yes	Yes								
Vehicle Extension (s)		3.0	3.0	3.0	3.0					3.0	3.0	
Recall Mode		Max	Max	None	Max					None	None	
Walk Time (s)		7.0	7.0		7.0							
Flash Don't Walk (s)		20.0	20.0		25.0							
Pedestrian Calls (#/hr)		0	0		0							
Act Effct Green (s)		27.9	27.9	18.0	49.9					10.3	10.3	
Actuated g/C Ratio		0.40	0.40	0.26	0.71					0.15	0.15	
v/c Ratio		0.46	0.60	1.09	0.50					1.32	0.99	
Control Delay (s/veh)		16.8	6.4	98.8	5.3					200.3	72.4	
Queue Delay		0.0	0.0	0.0	0.0					0.0	0.0	
Total Delay (s/veh)		16.8	6.4	98.8	5.3					200.3	72.4	
LOS		B	A	F	A					F	E	
Approach Delay (s/veh)		12.2			31.8						138.7	
Approach LOS		B			C						F	

Intersection Summary

Area Type: Other

Cycle Length: 70

Actuated Cycle Length: 70

Natural Cycle: 90

Control Type: Actuated-Uncoordinated

Maximum v/c Ratio: 1.32

Intersection Signal Delay (s/veh): 44.2

Intersection LOS: D

Intersection Capacity Utilization 82.4%

ICU Level of Service E

Analysis Period (min) 15

Splits and Phases: 12: US 101 SB On Ramp/US 101 SB Off Ramp & Old Redwood Highway

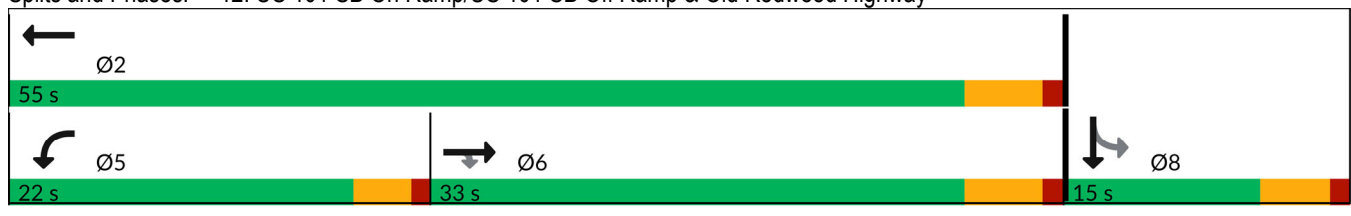

Lanes, Volumes, Timings  
1: Old Redwood Hwy & Shiloh Road

General Plan 2040 Conditions  
Timing Plan: Saturday Midday Peak

Lane Group	EBL	EBT	EBR	WBL	WBT	WBR	NBL	NBT	NBR	SBL	SBT	SBR
Lane Configurations												
Traffic Volume (vph)	182	105	216	31	105	22	221	338	35	30	272	266
Future Volume (vph)	182	105	216	31	105	22	221	338	35	30	272	266
Ideal Flow (vphpl)	1900	1900	1900	1900	1900	1900	1900	1900	1900	1900	1900	1900
Storage Length (ft)	375		140	0		50	200		98	130		93
Storage Lanes	1		1	0		1	1		1	1		1
Taper Length (ft)	50			25			60			93		
Lane Util. Factor	1.00	1.00	1.00	1.00	1.00	1.00	1.00	1.00	1.00	1.00	1.00	1.00
Ped Bike Factor	0.99		0.98						0.98			0.97
Frt			0.850			0.850			0.850			0.850
Flt Protected	0.950				0.989		0.950			0.950		
Satd. Flow (prot)	1770	1863	1583	0	1842	1583	1770	1863	1583	1770	1863	1583
Flt Permitted	0.950				0.989		0.950			0.950		
Satd. Flow (perm)	1760	1863	1549	0	1842	1583	1770	1863	1550	1770	1863	1540
Right Turn on Red			Yes			Yes			Yes			Yes
Satd. Flow (RTOR)			243			113			81			166
Link Speed (mph)		40			40			45			40	
Link Distance (ft)		1789			608			748			775	
Travel Time (s)		30.5			10.4			11.3			13.2	
Confl. Peds. (#/hr)	4											
Confl. Bikes (#/hr)			1						1			5
Peak Hour Factor	0.89	0.89	0.89	0.86	0.86	0.86	0.93	0.93	0.93	0.91	0.91	0.91
Adj. Flow (vph)	204	118	243	36	122	26	238	363	38	33	299	292
Shared Lane Traffic (%)												
Lane Group Flow (vph)	204	118	243	0	158	26	238	363	38	33	299	292
Enter Blocked Intersection	No	No	No	No	No	No	No	No	No	No	No	No
Lane Alignment	Left	Left	Right	Left	Left	Right	Left	Left	Right	Left	Left	Right
Median Width(ft)		12			12			12			12	
Link Offset(ft)		0			0			0			0	
Crosswalk Width(ft)		16			16			16			16	
Two way Left Turn Lane												
Headway Factor	1.00	1.00	1.00	1.00	1.00	1.00	1.00	1.00	1.00	1.00	1.00	1.00
Turning Speed (mph)	15		9	15		9	15		9	15		9
Number of Detectors	1	2	1	1	2	1	1	2	1	1	2	1
Detector Template	Left	Thru	Right	Left	Thru	Right	Left	Thru	Right	Left	Thru	Right
Leading Detector (ft)	20	100	20	20	100	20	20	100	20	20	100	20
Trailing Detector (ft)	0	0	0	0	0	0	0	0	0	0	0	0
Detector 1 Position(ft)	0	0	0	0	0	0	0	0	0	0	0	0
Detector 1 Size(ft)	20	6	20	20	6	20	20	6	20	20	6	20
Detector 1 Type	Cl+Ex	Cl+Ex	Cl+Ex	Cl+Ex	Cl+Ex	Cl+Ex	Cl+Ex	Cl+Ex	Cl+Ex	Cl+Ex	Cl+Ex	Cl+Ex
Detector 1 Channel												
Detector 1 Extend (s)	0.0	0.0	0.0	0.0	0.0	0.0	0.0	0.0	0.0	0.0	0.0	0.0
Detector 1 Queue (s)	0.0	0.0	0.0	0.0	0.0	0.0	0.0	0.0	0.0	0.0	0.0	0.0
Detector 1 Delay (s)	0.0	0.0	0.0	0.0	0.0	0.0	0.0	0.0	0.0	0.0	0.0	0.0
Detector 2 Position(ft)		94			94			94			94	
Detector 2 Size(ft)		6			6			6			6	
Detector 2 Type		Cl+Ex			Cl+Ex			Cl+Ex			Cl+Ex	
Detector 2 Channel												
Detector 2 Extend (s)		0.0			0.0			0.0			0.0	

Lanes, Volumes, Timings  
1: Old Redwood Hwy & Shiloh Road

General Plan 2040 Conditions  
Timing Plan: Saturday Midday Peak

Lane Group	EBL	EBT	EBR	WBL	WBT	WBR	NBL	NBT	NBR	SBL	SBT	SBR
Turn Type	Split	NA	Perm	Split	NA	Perm	Prot	NA	Perm	Prot	NA	Perm
Protected Phases	2	2		6	6		3	8		7	4	
Permitted Phases			2			6			8			4
Detector Phase	2	2	2	6	6	6	3	8	8	7	4	4
Switch Phase												
Minimum Initial (s)	5.0	5.0	5.0	5.0	5.0	5.0	5.0	5.0	5.0	5.0	5.0	5.0
Minimum Split (s)	34.5	34.5	34.5	42.5	42.5	42.5	9.0	46.5	46.5	9.0	39.5	39.5
Total Split (s)	35.0	35.0	35.0	42.5	42.5	42.5	18.0	48.0	48.0	9.5	39.5	39.5
Total Split (%)	25.9%	25.9%	25.9%	31.5%	31.5%	31.5%	13.3%	35.6%	35.6%	7.0%	29.3%	29.3%
Maximum Green (s)	30.5	30.5	30.5	38.0	38.0	38.0	14.0	43.5	43.5	5.5	35.0	35.0
Yellow Time (s)	3.5	3.5	3.5	3.5	3.5	3.5	3.5	3.5	3.5	3.5	3.5	3.5
All-Red Time (s)	1.0	1.0	1.0	1.0	1.0	1.0	0.5	1.0	1.0	0.5	1.0	1.0
Lost Time Adjust (s)	0.0	0.0	0.0		0.0	0.0	0.0	0.0	0.0	0.0	0.0	0.0
Total Lost Time (s)	4.5	4.5	4.5		4.5	4.5	4.0	4.5	4.5	4.0	4.5	4.5
Lead/Lag	Lead	Lead	Lead	Lag	Lag	Lag	Lead	Lag	Lag	Lead	Lag	Lag
Lead-Lag Optimize?	Yes	Yes	Yes	Yes	Yes	Yes	Yes	Yes	Yes	Yes	Yes	Yes
Vehicle Extension (s)	3.0	3.0	3.0	3.0	3.0	3.0	3.0	3.0	3.0	3.0	3.0	3.0
Recall Mode	None	None	None	None	None	None	None	None	None	None	None	None
Walk Time (s)	7.0	7.0	7.0	7.0	7.0	7.0		7.0	7.0		7.0	7.0
Flash Don't Walk (s)	23.0	23.0	23.0	31.0	31.0	31.0		35.0	35.0		28.0	28.0
Pedestrian Calls (#/hr)	0	0	0	0	0	0		0	0		0	0
Act Effct Green (s)	16.2	16.2	16.2		13.2	13.2	14.6	33.4	33.4	5.7	19.7	19.7
Actuated g/C Ratio	0.20	0.20	0.20		0.16	0.16	0.18	0.41	0.41	0.07	0.24	0.24
v/c Ratio	0.58	0.32	0.49		0.53	0.07	0.76	0.48	0.06	0.27	0.67	0.59
Control Delay (s/veh)	38.9	32.8	8.1		41.1	0.4	53.2	23.7	0.5	48.8	37.2	18.0
Queue Delay	0.0	0.0	0.0		0.0	0.0	0.0	0.0	0.0	0.0	0.0	0.0
Total Delay (s/veh)	38.9	32.8	8.1		41.1	0.4	53.2	23.7	0.5	48.8	37.2	18.0
LOS	D	C	A		D	A	D	C	A	D	D	B
Approach Delay (s/veh)		24.4			35.4			33.3			28.8	
Approach LOS		C			D			C			C	

Intersection Summary





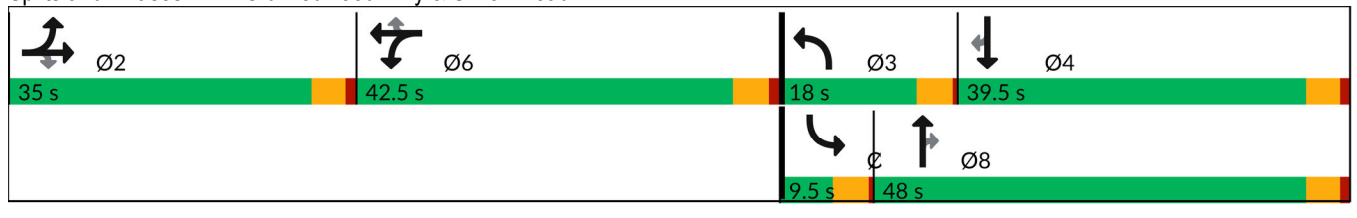















Area Type: Other  
 Cycle Length: 135  
 Actuated Cycle Length: 81.9  
 Natural Cycle: 135  
 Control Type: Actuated-Uncoordinated  
 Maximum v/c Ratio: 0.76  
 Intersection Signal Delay (s/veh): 29.6  
 Intersection LOS: C  
 Intersection Capacity Utilization 54.1%  
 ICU Level of Service A  
 Analysis Period (min) 15

Splits and Phases: 1: Old Redwood Hwy & Shiloh Road



Lanes, Volumes, Timings  
2: Shiloh Road & Hembree Ln

General Plan 2040 Conditions  
Timing Plan: Saturday Midday Peak

												
Lane Group	EBL	EBT	EBR	WBL	WBT	WBR	NBL	NBT	NBR	SBL	SBT	SBR
Lane Configurations												
Traffic Volume (vph)	918	372	69	110	298	235	111	21	128	236	11	856
Future Volume (vph)	918	372	69	110	298	235	111	21	128	236	11	856
Ideal Flow (vphpl)	1900	1900	1900	1900	1900	1900	1900	1900	1900	1900	1900	1900
Storage Length (ft)	0		0	100		130	0		0	0		0
Storage Lanes	2		0	1		1	1		0	0		1
Taper Length (ft)	25			50			25			25		
Lane Util. Factor	0.97	1.00	1.00	1.00	0.95	0.95	1.00	1.00	1.00	1.00	1.00	1.00
Ped Bike Factor	1.00				0.99							
Frt		0.978			0.934			0.871				0.850
Flt Protected	0.950			0.950			0.950				0.954	
Satd. Flow (prot)	3433	1822	0	1770	3287	0	1770	1622	0	0	1777	1583
Flt Permitted	0.950			0.950			0.950				0.954	
Satd. Flow (perm)	3431	1822	0	1770	3287	0	1770	1622	0	0	1777	1583
Right Turn on Red			Yes			Yes			Yes			Yes
Satd. Flow (RTOR)		17			245			128				414
Link Speed (mph)		40			40			30				35
Link Distance (ft)		302			1789			216				381
Travel Time (s)		5.1			30.5			4.9				7.4
Confl. Peds. (#/hr)	1						1					
Peak Hour Factor	0.94	0.94	1.00	1.00	0.96	0.96	1.00	1.00	1.00	0.91	1.00	0.91
Adj. Flow (vph)	977	396	69	110	310	245	111	21	128	259	11	941
Shared Lane Traffic (%)												
Lane Group Flow (vph)	977	465	0	110	555	0	111	149	0	0	270	941
Enter Blocked Intersection	No	No	No	No	No	No	No	No	No	No	No	No
Lane Alignment	Left	Left	Right	Left	Left	Right	Left	Left	Right	Left	Left	Right
Median Width(ft)		24			24			12				12
Link Offset(ft)		0			0			0				0
Crosswalk Width(ft)		16			16			16				16
Two way Left Turn Lane												
Headway Factor	1.00	1.00	1.00	1.00	1.00	1.00	1.00	1.00	1.00	1.00	1.00	1.00
Turning Speed (mph)	15		9	15		9	15		9	15		9
Number of Detectors	1	2		1	2		1	2		1	2	1
Detector Template	Left	Thru		Left	Thru		Left	Thru		Left	Thru	Right
Leading Detector (ft)	20	100		20	100		20	100		20	100	20
Trailing Detector (ft)	0	0		0	0		0	0		0	0	0
Detector 1 Position(ft)	0	0		0	0		0	0		0	0	0
Detector 1 Size(ft)	20	6		20	6		20	6		20	6	20
Detector 1 Type	Cl+Ex	Cl+Ex		Cl+Ex	Cl+Ex		Cl+Ex	Cl+Ex		Cl+Ex	Cl+Ex	Cl+Ex
Detector 1 Channel												
Detector 1 Extend (s)	0.0	0.0		0.0	0.0		0.0	0.0		0.0	0.0	0.0
Detector 1 Queue (s)	0.0	0.0		0.0	0.0		0.0	0.0		0.0	0.0	0.0
Detector 1 Delay (s)	0.0	0.0		0.0	0.0		0.0	0.0		0.0	0.0	0.0
Detector 2 Position(ft)		94			94			94				94
Detector 2 Size(ft)		6			6			6				6
Detector 2 Type		Cl+Ex			Cl+Ex			Cl+Ex				Cl+Ex
Detector 2 Channel												
Detector 2 Extend (s)		0.0			0.0			0.0				0.0
Turn Type	Prot	NA		Prot	NA		Split	NA		Split	NA	pt+ov

Lanes, Volumes, Timings  
2: Shiloh Road & Hembree Ln

General Plan 2040 Conditions  
Timing Plan: Saturday Midday Peak

Lane Group	EBL	EBT	EBR	WBL	WBT	WBR	NBL	NBT	NBR	SBL	SBT	SBR
Protected Phases	5	2		1	6		8	8		4	4	4 5
Permitted Phases												
Detector Phase	5	2		1	6		8	8		4	4	4 5
Switch Phase												
Minimum Initial (s)	3.0	5.0		5.0	5.0		5.0	5.0		5.0	5.0	
Minimum Split (s)	7.5	9.5		9.5	43.5		9.5	9.5		9.5	9.5	
Total Split (s)	21.0	57.0		9.5	45.5		9.5	9.5		14.0	14.0	
Total Split (%)	23.3%	63.3%		10.6%	50.6%		10.6%	10.6%		15.6%	15.6%	
Maximum Green (s)	17.0	53.0		5.5	41.5		5.5	5.5		10.0	10.0	
Yellow Time (s)	3.0	3.0		3.0	3.0		3.0	3.0		3.0	3.0	
All-Red Time (s)	1.0	1.0		1.0	1.0		1.0	1.0		1.0	1.0	
Lost Time Adjust (s)	0.0	0.0		0.0	0.0		0.0	0.0		0.0	0.0	
Total Lost Time (s)	4.0	4.0		4.0	4.0		4.0	4.0		4.0	4.0	
Lead/Lag	Lead	Lag		Lead	Lag							
Lead-Lag Optimize?	Yes	Yes		Yes	Yes							
Vehicle Extension (s)	3.0	3.0		3.0	3.0		3.0	3.0		3.0	3.0	
Recall Mode	None	None		None	None		None	None		None	None	
Walk Time (s)					7.0							
Flash Don't Walk (s)					32.0							
Pedestrian Calls (#/hr)					1							
Act Effct Green (s)	17.5	27.0		5.6	15.2		5.6	5.6		10.3	27.7	
Actuated g/C Ratio	0.27	0.42		0.09	0.23		0.09	0.09		0.16	0.43	
v/c Ratio	1.06	0.61		0.72	0.58		0.73	0.58		0.96	1.03	
Control Delay (s/veh)	74.1	17.1		60.2	13.5		60.8	20.2		78.6	50.7	
Queue Delay	0.0	0.0		0.0	0.0		0.0	0.0		0.0	0.0	
Total Delay (s/veh)	74.1	17.1		60.2	13.5		60.8	20.2		78.6	50.7	
LOS	E	B		E	B		E	C		E	D	
Approach Delay (s/veh)		55.7			21.2			37.6			57.0	
Approach LOS		E			C			D			E	

Intersection Summary







Area Type:	Other
Cycle Length:	90
Actuated Cycle Length:	65
Natural Cycle:	140
Control Type:	Actuated-Uncoordinated
Maximum v/c Ratio:	1.06
Intersection Signal Delay (s/veh):	48.4
Intersection LOS:	D
Intersection Capacity Utilization:	88.4%
ICU Level of Service:	E
Analysis Period (min):	15

Splits and Phases: 2: Shiloh Road & Hembree Ln



Lanes, Volumes, Timings  
3: US 101 NB Off-Ramp & Shiloh Road

General Plan 2040 Conditions  
Timing Plan: Saturday Midday Peak

						
Lane Group	EBT	EBR	WBL	WBT	NBL	NBR
Lane Configurations	↑↑			↑	↓	↑↑
Traffic Volume (vph)	523	0	0	901	520	765
Future Volume (vph)	523	0	0	901	520	765
Ideal Flow (vphp)	1900	1900	1900	1900	1900	1900
Storage Length (ft)		0	0		0	265
Storage Lanes		0	0		1	2
Taper Length (ft)			25		25	
Lane Util. Factor	0.95	1.00	1.00	1.00	1.00	0.88
Ped Bike Factor						
Frt						0.850
Flt Protected					0.950	
Satd. Flow (prot)	3539	0	0	1863	1770	2787
Flt Permitted					0.950	
Satd. Flow (perm)	3539	0	0	1863	1770	2787
Right Turn on Red		Yes				Yes
Satd. Flow (RTOR)						363
Link Speed (mph)	40			40	30	
Link Distance (ft)	186			371	769	
Travel Time (s)	3.2			6.3	17.5	
Confl. Bikes (#/hr)		1				
Peak Hour Factor	0.91	0.91	0.89	0.89	0.95	0.95
Adj. Flow (vph)	575	0	0	1012	547	805
Shared Lane Traffic (%)						
Lane Group Flow (vph)	575	0	0	1012	547	805
Enter Blocked Intersection	No	No	No	No	No	No
Lane Alignment	Left	Right	Left	Left	Left	Right
Median Width(ft)	0			0	12	
Link Offset(ft)	0			0	0	
Crosswalk Width(ft)	16			16	16	
Two way Left Turn Lane						
Headway Factor	1.00	1.00	1.00	1.00	1.00	1.00
Turning Speed (mph)		9	15		15	9
Number of Detectors	2			2	1	1
Detector Template	Thru			Thru	Left	Right
Leading Detector (ft)	100			100	20	20
Trailing Detector (ft)	0			0	0	0
Detector 1 Position(ft)	0			0	0	0
Detector 1 Size(ft)	6			6	20	20
Detector 1 Type	Cl+Ex			Cl+Ex	Cl+Ex	Cl+Ex
Detector 1 Channel						
Detector 1 Extend (s)	0.0			0.0	0.0	0.0
Detector 1 Queue (s)	0.0			0.0	0.0	0.0
Detector 1 Delay (s)	0.0			0.0	0.0	0.0
Detector 2 Position(ft)	94			94		
Detector 2 Size(ft)	6			6		
Detector 2 Type	Cl+Ex			Cl+Ex		
Detector 2 Channel						
Detector 2 Extend (s)	0.0			0.0		
Turn Type	NA			NA	Prot	Perm

Lanes, Volumes, Timings  
 3: US 101 NB Off-Ramp & Shiloh Road

General Plan 2040 Conditions  
 Timing Plan: Saturday Midday Peak



Lane Group	EBT	EBR	WBL	WBT	NBL	NBR
Protected Phases	2			6	8	
Permitted Phases						8
Detector Phase	2			6	8	8
Switch Phase						
Minimum Initial (s)	5.0			5.0	5.0	5.0
Minimum Split (s)	9.5			9.5	9.5	9.5
Total Split (s)	37.0			37.0	35.0	35.0
Total Split (%)	51.4%			51.4%	48.6%	48.6%
Maximum Green (s)	32.5			32.5	30.5	30.5
Yellow Time (s)	3.5			3.5	3.5	3.5
All-Red Time (s)	1.0			1.0	1.0	1.0
Lost Time Adjust (s)	0.0			0.0	0.0	0.0
Total Lost Time (s)	4.5			4.5	4.5	4.5
Lead/Lag						
Lead-Lag Optimize?						
Vehicle Extension (s)	3.0			3.0	3.0	3.0
Recall Mode	None			None	None	None
Act Effct Green (s)	32.7			32.7	25.5	25.5
Actuated g/C Ratio	0.49			0.49	0.38	0.38
v/c Ratio	0.33			1.12	0.82	0.63
Control Delay (s/veh)	12.2			90.0	29.5	11.0
Queue Delay	0.0			0.0	0.0	0.0
Total Delay (s/veh)	12.2			90.0	29.5	11.0
LOS	B			F	C	B
Approach Delay (s/veh)	12.2			90.0	18.5	
Approach LOS	B			F	B	

Intersection Summary

Area Type: Other  
 Cycle Length: 72  
 Actuated Cycle Length: 67.3  
 Natural Cycle: 90  
 Control Type: Actuated-Uncoordinated  
 Maximum v/c Ratio: 1.12  
 Intersection Signal Delay (s/veh): 41.9  
 Intersection LOS: D  
 Intersection Capacity Utilization 121.2%  
 ICU Level of Service H  
 Analysis Period (min) 15

Splits and Phases: 3: US 101 NB Off-Ramp & Shiloh Road

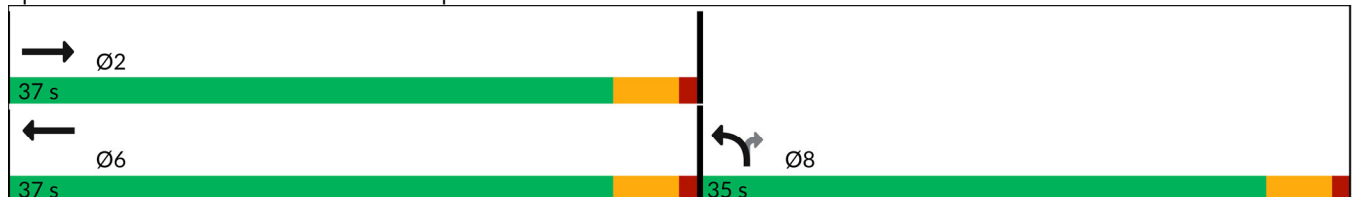



Lanes, Volumes, Timings  
4: Shiloh Road & US 101 SB Off-Ramp

General Plan 2040 Conditions  
Timing Plan: Saturday Midday Peak

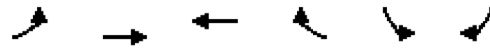

Lane Group	EBL	EBT	WBT	WBR	SBL	SBR
Lane Configurations		↑	↑		↘	↘
Traffic Volume (vph)	0	391	760	0	248	223
Future Volume (vph)	0	391	760	0	248	223
Ideal Flow (vphp)	1900	1900	1900	1900	1900	1900
Storage Length (ft)	0			0	0	275
Storage Lanes	0			0	1	1
Taper Length (ft)	25				25	
Lane Util. Factor	1.00	1.00	1.00	1.00	1.00	1.00
Ped Bike Factor						
Frt						0.850
Flt Protected					0.950	
Satd. Flow (prot)	0	1863	1863	0	1770	1583
Flt Permitted					0.950	
Satd. Flow (perm)	0	1863	1863	0	1770	1583
Right Turn on Red				Yes		Yes
Satd. Flow (RTOR)						259
Link Speed (mph)		40	40		30	
Link Distance (ft)		225	306		486	
Travel Time (s)		3.8	5.2		11.0	
Confl. Bikes (#/hr)				2		
Peak Hour Factor	0.96	0.96	0.96	0.96	0.68	0.68
Adj. Flow (vph)	0	407	792	0	365	328
Shared Lane Traffic (%)						
Lane Group Flow (vph)	0	407	792	0	365	328
Enter Blocked Intersection	No	No	No	No	No	No
Lane Alignment	Left	Left	Left	Right	Left	Right
Median Width(ft)		4	0		12	
Link Offset(ft)		0	0		0	
Crosswalk Width(ft)		16	16		16	
Two way Left Turn Lane						
Headway Factor	1.00	1.00	1.00	1.00	1.00	1.00
Turning Speed (mph)	15			9	15	9
Number of Detectors		2	2		1	1
Detector Template		Thru	Thru		Left	Right
Leading Detector (ft)		100	100		20	20
Trailing Detector (ft)		0	0		0	0
Detector 1 Position(ft)		0	0		0	0
Detector 1 Size(ft)		6	6		20	20
Detector 1 Type		Cl+Ex	Cl+Ex		Cl+Ex	Cl+Ex
Detector 1 Channel						
Detector 1 Extend (s)		0.0	0.0		0.0	0.0
Detector 1 Queue (s)		0.0	0.0		0.0	0.0
Detector 1 Delay (s)		0.0	0.0		0.0	0.0
Detector 2 Position(ft)		94	94			
Detector 2 Size(ft)		6	6			
Detector 2 Type		Cl+Ex	Cl+Ex			
Detector 2 Channel						
Detector 2 Extend (s)		0.0	0.0			
Turn Type		NA	NA		Perm	Perm

Lanes, Volumes, Timings  
4: Shiloh Road & US 101 SB Off-Ramp

General Plan 2040 Conditions  
Timing Plan: Saturday Midday Peak



Lane Group	EBL	EBT	WBT	WBR	SBL	SBR
Protected Phases		2	6			
Permitted Phases					4	4
Detector Phase		2	6		4	4
Switch Phase						
Minimum Initial (s)		5.0	5.0		5.0	5.0
Minimum Split (s)		9.5	38.5		9.5	9.5
Total Split (s)		69.0	69.0		21.0	21.0
Total Split (%)		76.7%	76.7%		23.3%	23.3%
Maximum Green (s)		64.5	64.5		16.5	16.5
Yellow Time (s)		3.5	3.5		3.5	3.5
All-Red Time (s)		1.0	1.0		1.0	1.0
Lost Time Adjust (s)		0.0	0.0		0.0	0.0
Total Lost Time (s)		4.5	4.5		4.5	4.5
Lead/Lag						
Lead-Lag Optimize?						
Vehicle Extension (s)		3.0	3.0		3.0	3.0
Recall Mode		None	None		None	None
Walk Time (s)			7.0			
Flash Don't Walk (s)			27.0			
Pedestrian Calls (#/hr)			0			
Act Effct Green (s)		28.8	28.8		16.9	16.9
Actuated g/C Ratio		0.52	0.52		0.31	0.31
v/c Ratio		0.42	0.81		0.67	0.49
Control Delay (s/veh)		8.8	17.8		27.9	8.3
Queue Delay		0.0	0.0		0.0	0.0
Total Delay (s/veh)		8.8	17.8		27.9	8.3
LOS		A	B		C	A
Approach Delay (s/veh)		8.8	17.8		18.7	
Approach LOS		A	B		B	

Intersection Summary

Area Type:	Other
Cycle Length:	90
Actuated Cycle Length:	54.9
Natural Cycle:	60
Control Type:	Actuated-Uncoordinated
Maximum v/c Ratio:	0.81
Intersection Signal Delay (s/veh):	16.2
Intersection LOS:	B
Intersection Capacity Utilization:	124.8%
ICU Level of Service:	H
Analysis Period (min):	15

Splits and Phases: 4: Shiloh Road & US 101 SB Off-Ramp

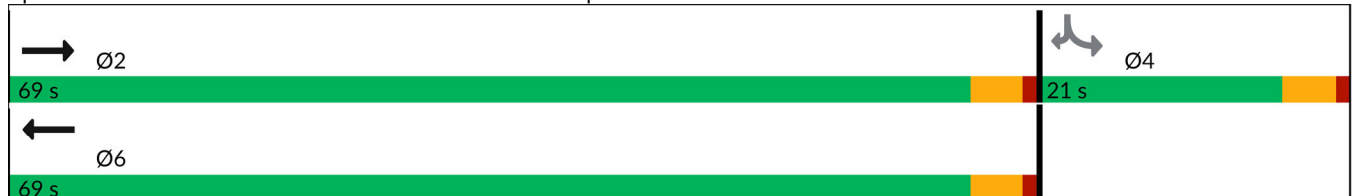



















Lanes, Volumes, Timings  
5: Caletti Ave & Shiloh Road

General Plan 2040 Conditions  
Timing Plan: Saturday Midday Peak

	→	↘	↙	←	↖	↗
Lane Group	EBT	EBR	WBL	WBT	NBL	NBR
Lane Configurations	↑↑		↘	↑	↘	↗
Traffic Volume (vph)	793	30	120	877	24	115
Future Volume (vph)	793	30	120	877	24	115
Ideal Flow (vphp)	1900	1900	1900	1900	1900	1900
Storage Length (ft)		0	68		0	0
Storage Lanes		0	1		1	1
Taper Length (ft)			50		25	
Lane Util. Factor	0.95	0.95	1.00	1.00	1.00	1.00
Ped Bike Factor						
Frt	0.994					0.850
Flt Protected			0.950		0.950	
Satd. Flow (prot)	3518	0	1770	1863	1770	1583
Flt Permitted			0.950		0.950	
Satd. Flow (perm)	3518	0	1770	1863	1770	1583
Link Speed (mph)	40			40	30	
Link Distance (ft)	1081			184	459	
Travel Time (s)	18.4			3.1	10.4	
Confl. Peds. (#/hr)					1	
Confl. Bikes (#/hr)		1				
Peak Hour Factor	0.92	0.92	0.87	0.87	0.78	0.78
Adj. Flow (vph)	862	33	138	1008	31	147
Shared Lane Traffic (%)						
Lane Group Flow (vph)	895	0	138	1008	31	147
Enter Blocked Intersection	No	No	No	No	No	No
Lane Alignment	Left	Right	Left	Left	Left	Right
Median Width(ft)	12			12	12	
Link Offset(ft)	0			0	0	
Crosswalk Width(ft)	16			16	16	
Two way Left Turn Lane						
Headway Factor	1.00	1.00	1.00	1.00	1.00	1.00
Turning Speed (mph)		9	15		15	9
Sign Control	Free			Free	Stop	
<b>Intersection Summary</b>						
Area Type:	Other					
Control Type:	Unsignalized					
Intersection Capacity Utilization	56.2%			ICU Level of Service B		
Analysis Period (min)	15					

Lanes, Volumes, Timings  
6: Conde Lane & Shiloh Road

General Plan 2040 Conditions  
Timing Plan: Saturday Midday Peak

												
Lane Group	EBL	EBT	EBR	WBL	WBT	WBR	NBL	NBT	NBR	SBL	SBT	SBR
Lane Configurations												
Traffic Volume (vph)	43	521	1	13	580	301	1	0	9	291	0	41
Future Volume (vph)	43	521	1	13	580	301	1	0	9	291	0	41
Ideal Flow (vphpl)	1900	1900	1900	1900	1900	1900	1900	1900	1900	1900	1900	1900
Storage Length (ft)	90		0	127		0	0		0	0		40
Storage Lanes	1		0	1		0	0		0	0		1
Taper Length (ft)	70			40			25			25		
Lane Util. Factor	1.00	0.95	0.95	1.00	0.95	0.95	1.00	1.00	1.00	1.00	1.00	1.00
Ped Bike Factor					0.99							
Frt					0.949			0.880				0.850
Flt Protected	0.950			0.950				0.994			0.950	
Satd. Flow (prot)	1770	3539	0	1770	3333	0	0	1629	0	0	1770	1583
Flt Permitted	0.950			0.950				0.994			0.950	
Satd. Flow (perm)	1770	3539	0	1770	3333	0	0	1629	0	0	1770	1583
Right Turn on Red			Yes			Yes			Yes			No
Satd. Flow (RTOR)					95			102				
Link Speed (mph)		40			40			30				35
Link Distance (ft)		815			1081			418				522
Travel Time (s)		13.9			18.4			9.5				10.2
Confl. Bikes (#/hr)						2						
Peak Hour Factor	0.96	0.96	0.96	0.91	0.91	0.91	0.58	0.58	0.58	0.78	0.78	0.78
Adj. Flow (vph)	45	543	1	14	637	331	2	0	16	373	0	53
Shared Lane Traffic (%)												
Lane Group Flow (vph)	45	544	0	14	968	0	0	18	0	0	373	53
Enter Blocked Intersection	No	No	No	No	No	No	No	No	No	No	No	No
Lane Alignment	Left	Left	Right	Left	Left	Right	Left	Left	Right	Left	Left	Right
Median Width(ft)		12			12			0				0
Link Offset(ft)		0			0			0				0
Crosswalk Width(ft)		16			16			16				16
Two way Left Turn Lane												
Headway Factor	1.00	1.00	1.00	1.00	1.00	1.00	1.00	1.00	1.00	1.00	1.00	1.00
Turning Speed (mph)	15		9	15		9	15		9	15		9
Number of Detectors	1	2		1	2		1	2		1	1	1
Detector Template	Left	Thru		Left	Thru		Left	Thru		Left	Thru	Right
Leading Detector (ft)	20	100		20	100		20	100		20	30	20
Trailing Detector (ft)	0	0		0	0		0	0		0	0	0
Detector 1 Position(ft)	0	0		0	0		0	0		0	0	0
Detector 1 Size(ft)	20	6		20	6		20	6		20	30	20
Detector 1 Type	Cl+Ex	Cl+Ex		Cl+Ex	Cl+Ex		Cl+Ex	Cl+Ex		Cl+Ex	Cl+Ex	Cl+Ex
Detector 1 Channel												
Detector 1 Extend (s)	0.0	0.0		0.0	0.0		0.0	0.0		0.0	0.0	0.0
Detector 1 Queue (s)	0.0	0.0		0.0	0.0		0.0	0.0		0.0	0.0	0.0
Detector 1 Delay (s)	0.0	0.0		0.0	0.0		0.0	0.0		0.0	0.0	0.0
Detector 2 Position(ft)		94			94			94				
Detector 2 Size(ft)		6			6			6				
Detector 2 Type		Cl+Ex			Cl+Ex			Cl+Ex				
Detector 2 Channel												
Detector 2 Extend (s)		0.0			0.0			0.0				
Turn Type	Prot	NA		Prot	NA		Split	NA		Split	NA	custom

Lanes, Volumes, Timings  
6: Conde Lane & Shiloh Road

General Plan 2040 Conditions  
Timing Plan: Saturday Midday Peak

Lane Group	EBL	EBT	EBR	WBL	WBT	WBR	NBL	NBT	NBR	SBL	SBT	SBR
Protected Phases	5	2		1	6		7	7		4	4	
Permitted Phases												6
Detector Phase	5	2		1	6		7	7		4	4	6
Switch Phase												
Minimum Initial (s)	8.0	8.0		8.0	8.0		10.0	10.0		11.0	11.0	8.0
Minimum Split (s)	12.5	46.5		12.5	12.5		37.5	37.5		15.5	15.5	12.5
Total Split (s)	13.0	46.5		12.5	45.0		37.5	37.5		15.5	15.5	45.0
Total Split (%)	11.6%	41.5%		11.2%	40.2%		33.5%	33.5%		13.8%	13.8%	40.2%
Maximum Green (s)	8.5	42.0		8.0	40.5		33.0	33.0		11.0	11.0	40.5
Yellow Time (s)	3.5	3.5		3.5	3.5		3.5	3.5		3.5	3.5	3.5
All-Red Time (s)	1.0	1.0		1.0	1.0		1.0	1.0		1.0	1.0	1.0
Lost Time Adjust (s)	0.0	0.0		0.0	0.0		0.0	0.0		0.0	0.0	0.0
Total Lost Time (s)	4.5	4.5		4.5	4.5		4.5	4.5		4.5	4.5	4.5
Lead/Lag	Lead	Lag		Lead	Lag							Lag
Lead-Lag Optimize?	Yes	Yes		Yes	Yes							Yes
Vehicle Extension (s)	3.0	3.0		3.0	3.0		3.0	3.0		3.0	3.0	3.0
Recall Mode	None	None		None	None		None	None		None	None	None
Walk Time (s)		7.0					7.0	7.0				
Flash Don't Walk (s)		35.0					26.0	26.0				
Pedestrian Calls (#/hr)		0					0	0				
Act Effct Green (s)	9.3	29.4		9.1	24.7			11.4			12.6	24.7
Actuated g/C Ratio	0.16	0.51		0.16	0.43			0.20			0.22	0.43
v/c Ratio	0.16	0.30		0.05	0.66			0.04			0.98	0.08
Control Delay (s/veh)	31.9	9.9		32.2	15.8			0.2			74.4	13.3
Queue Delay	0.0	0.0		0.0	0.0			0.0			0.0	0.0
Total Delay (s/veh)	31.9	9.9		32.2	15.8			0.2			74.4	13.3
LOS	C	A		C	B			A			E	B
Approach Delay (s/veh)		11.5			16.1			0.2			66.8	
Approach LOS		B			B			A			E	

Intersection Summary





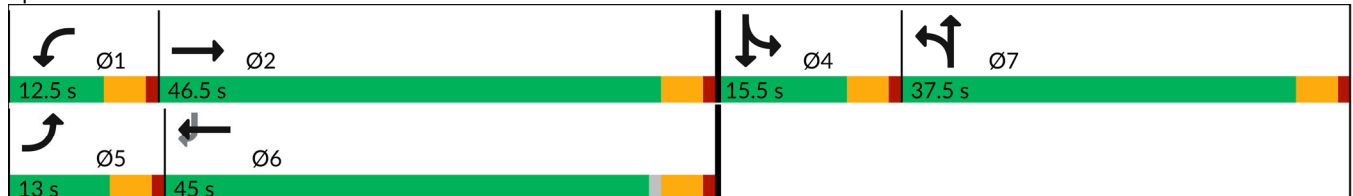











Area Type:	Other
Cycle Length:	112
Actuated Cycle Length:	58.1
Natural Cycle:	125
Control Type:	Actuated-Uncoordinated
Maximum v/c Ratio:	0.98
Intersection Signal Delay (s/veh):	25.3
Intersection LOS:	C
Intersection Capacity Utilization:	66.0%
ICU Level of Service:	C
Analysis Period (min):	15

Splits and Phases: 6: Conde Lane & Shiloh Road





















Lanes, Volumes, Timings  
7: Entrance 1/Gridley Drive & Shiloh Road

General Plan 2040 Conditions  
Timing Plan: Saturday Midday Peak

												
Lane Group	EBL	EBT	EBR	WBL	WBT	WBR	NBL	NBT	NBR	SBL	SBT	SBR
Lane Configurations												
Traffic Volume (vph)	30	157	0	0	136	0	0	0	0	0	0	27
Future Volume (vph)	30	157	0	0	136	0	0	0	0	0	0	27
Ideal Flow (vphpl)	1900	1900	1900	1900	1900	1900	1900	1900	1900	1900	1900	1900
Lane Util. Factor	1.00	1.00	1.00	1.00	1.00	1.00	1.00	1.00	1.00	1.00	1.00	1.00
Ped Bike Factor												
Frt												0.865
Flt Protected	0.992											
Satd. Flow (prot)	0	1848	0	0	1863	0	1863	1863	0	0	1611	0
Flt Permitted	0.992											
Satd. Flow (perm)	0	1848	0	0	1863	0	1863	1863	0	0	1611	0
Link Speed (mph)	40		40				30		30			
Link Distance (ft)	608		2146				248		715			
Travel Time (s)	10.4		36.6				5.6		16.3			
Confl. Peds. (#/hr)	1											
Confl. Bikes (#/hr)	1				3							
Peak Hour Factor	0.93	0.93	0.93	0.88	0.88	0.88	1.00	1.00	1.00	0.56	0.56	0.56
Adj. Flow (vph)	32	169	0	0	155	0	0	0	0	0	0	48
Shared Lane Traffic (%)												
Lane Group Flow (vph)	0	201	0	0	155	0	0	0	0	0	48	0
Enter Blocked Intersection	No	No	No	No	No	No	No	No	No	No	No	No
Lane Alignment	Left	Left	Right	Left	Left	Right	Left	Left	Right	Left	Left	Right
Median Width(ft)	0		0				12		12			
Link Offset(ft)	0		0				0		0			
Crosswalk Width(ft)	16		16				16		16			
Two way Left Turn Lane												
Headway Factor	1.00	1.00	1.00	1.00	1.00	1.00	1.00	1.00	1.00	1.00	1.00	1.00
Turning Speed (mph)	15		9		15		9		15		9	
Sign Control	Free				Free				Stop			
<b>Intersection Summary</b>												
Area Type:	Other											
Control Type:	Unsignalized											
Intersection Capacity Utilization	30.4%						ICU Level of Service A					
Analysis Period (min)	15											

Lanes, Volumes, Timings  
8: Old Redwood Hwy & Entrance 1

General Plan 2040 Conditions  
Timing Plan: Saturday Midday Peak

												
Lane Group	EBL	EBT	EBR	WBL	WBT	WBR	NBL	NBT	NBR	SBL	SBT	SBR
Lane Configurations												
Traffic Volume (vph)	1	0	3	0	0	0	1	595	0	0	505	6
Future Volume (vph)	1	0	3	0	0	0	1	595	0	0	505	6
Ideal Flow (vphp)	1900	1900	1900	1900	1900	1900	1900	1900	1900	1900	1900	1900
Storage Length (ft)	0		0	0		0	0		0	50		0
Storage Lanes	0		0	1		0	0		0	1		0
Taper Length (ft)	25			25			25			25		
Lane Util. Factor	1.00	1.00	1.00	1.00	1.00	1.00	1.00	1.00	1.00	1.00	1.00	1.00
Ped Bike Factor												
Frt		0.902									0.998	
Flt Protected		0.987										
Satd. Flow (prot)	0	1658	0	1863	1863	0	0	1863	0	1863	1859	0
Flt Permitted		0.987										
Satd. Flow (perm)	0	1658	0	1863	1863	0	0	1863	0	1863	1859	0
Link Speed (mph)		30			30			45			45	
Link Distance (ft)		98			385			520			748	
Travel Time (s)		2.2			8.8			7.9			11.3	
Confl. Peds. (#/hr)							1		4	4		1
Confl. Bikes (#/hr)									3			9
Peak Hour Factor	0.38	0.38	0.38	1.00	1.00	1.00	0.94	0.94	0.94	0.93	0.93	0.93
Adj. Flow (vph)	3	0	8	0	0	0	1	633	0	0	543	6
Shared Lane Traffic (%)												
Lane Group Flow (vph)	0	11	0	0	0	0	0	634	0	0	549	0
Enter Blocked Intersection	No	No	No	No	No	No	No	No	No	No	No	No
Lane Alignment	Left	Left	Right	Left	Left	Right	Left	Left	Right	Left	Left	Right
Median Width(ft)		12			12			12			12	
Link Offset(ft)		0			0			0			0	
Crosswalk Width(ft)		16			16			16			16	
Two way Left Turn Lane												
Headway Factor	1.00	1.00	1.00	1.00	1.00	1.00	1.00	1.00	1.00	1.00	1.00	1.00
Turning Speed (mph)	15		9	15		9	15		9	15		9
Sign Control		Stop			Stop			Free			Free	
<b>Intersection Summary</b>												
Area Type:	Other											
Control Type:	Unsignalized											
Intersection Capacity Utilization	42.1%						ICU Level of Service A					
Analysis Period (min)	15											

Lanes, Volumes, Timings  
9: Entrance 2 & Shiloh Road

General Plan 2040 Conditions  
Timing Plan: Saturday Midday Peak

	→	↘	↙	←	↖	↗
Lane Group	EBT	EBR	WBL	WBT	NBL	NBR
Lane Configurations	↗			↖	↘	↗
Traffic Volume (vph)	136	0	0	127	0	0
Future Volume (vph)	136	0	0	127	0	0
Ideal Flow (vphpl)	1900	1900	1900	1900	1900	1900
Lane Util. Factor	1.00	1.00	1.00	1.00	1.00	1.00
Ped Bike Factor						
Frt						
Flt Protected						
Satd. Flow (prot)	1863	0	0	1863	1863	1863
Flt Permitted						
Satd. Flow (perm)	1863	0	0	1863	1863	1863
Link Speed (mph)	40			40	30	
Link Distance (ft)	2146			134	402	
Travel Time (s)	36.6			2.3	9.1	
Confl. Peds. (#/hr)		1				
Peak Hour Factor	0.88	0.88	0.80	0.80	1.00	1.00
Adj. Flow (vph)	155	0	0	159	0	0
Shared Lane Traffic (%)						
Lane Group Flow (vph)	155	0	0	159	0	0
Enter Blocked Intersection	No	No	No	No	No	No
Lane Alignment	Left	Right	Left	Left	Left	Right
Median Width(ft)	0			0	12	
Link Offset(ft)	0			0	0	
Crosswalk Width(ft)	16			16	16	
Two way Left Turn Lane						
Headway Factor	1.00	1.00	1.00	1.00	1.00	1.00
Turning Speed (mph)		9	15		15	9
Sign Control	Free			Free	Stop	
<b>Intersection Summary</b>						
Area Type:	Other					
Control Type:	Unsignalized					
Intersection Capacity Utilization	10.7%			ICU Level of Service A		
Analysis Period (min)	15					



Lanes, Volumes, Timings

General Plan 2040 Conditions

10: US 101 NB Off Ramp/Lakewood Drive & Old Redwood Highway Timing Plan: Saturday Midday Peak



Lane Group	EBL	EBT	EBR	WBL	WBT	WBR	NBL	NBT	NBR	SBL	SBT	SBR
Lane Configurations												
Traffic Volume (vph)	372	406	0	0	651	357	415	393	185	316	0	908
Future Volume (vph)	372	406	0	0	651	357	415	393	185	316	0	908
Ideal Flow (vphpl)	1900	1900	1900	1900	1900	1900	1900	1900	1900	1900	1900	1900
Storage Length (ft)	155		0	0		0	270		150	120		0
Storage Lanes	1		0	0		0	1		1	1		1
Taper Length (ft)	50			25			165			75		
Lane Util. Factor	0.97	1.00	1.00	1.00	0.95	0.95	0.91	0.91	0.95	0.97	1.00	1.00
Ped Bike Factor	1.00				0.99			1.00		1.00		
Flt					0.947			0.958				0.850
Flt Protected	0.950						0.950	0.994		0.950		
Satd. Flow (prot)	3433	1863	0	0	3332	0	1610	3217	0	3433	0	1583
Flt Permitted	0.950						0.950	0.994		0.950		
Satd. Flow (perm)	3430	1863	0	0	3332	0	1610	3217	0	3431	0	1583
Right Turn on Red			Yes			Yes			Yes			Yes
Satd. Flow (RTOR)					120			61				253
Link Speed (mph)		35			35			30				30
Link Distance (ft)		226			617			716				478
Travel Time (s)		4.4			12.0			16.3				10.9
Confl. Peds. (#/hr)	2		1	1		2			1	1		
Confl. Bikes (#/hr)			10			3						
Peak Hour Factor	0.95	0.95	0.95	0.89	0.89	0.89	0.98	0.98	0.98	0.88	0.88	0.88
Adj. Flow (vph)	392	427	0	0	731	401	423	401	189	359	0	1032
Shared Lane Traffic (%)							20%					
Lane Group Flow (vph)	392	427	0	0	1132	0	338	675	0	359	0	1032
Enter Blocked Intersection	No	No	No	No	No	No	No	No	No	No	No	No
Lane Alignment	Left	Left	Right	Left	Left	Right	Left	Left	Right	Left	Left	Right
Median Width(ft)		24			24			24				24
Link Offset(ft)		0			0			0				0
Crosswalk Width(ft)		16			16			16				16
Two way Left Turn Lane												
Headway Factor	1.00	1.00	1.00	1.00	1.00	1.00	1.00	1.00	1.00	1.00	1.00	1.00
Turning Speed (mph)	15		9	15		9	15		9	15		9
Number of Detectors	1	2			2		1	2		1		1
Detector Template	Left	Thru			Thru		Left	Thru		Left		Right
Leading Detector (ft)	20	100			100		20	100		20		20
Trailing Detector (ft)	0	0			0		0	0		0		0
Detector 1 Position(ft)	0	0			0		0	0		0		0
Detector 1 Size(ft)	20	6			6		20	6		20		20
Detector 1 Type	Cl+Ex	Cl+Ex			Cl+Ex		Cl+Ex	Cl+Ex		Cl+Ex		Cl+Ex
Detector 1 Channel												
Detector 1 Extend (s)	0.0	0.0			0.0		0.0	0.0		0.0		0.0
Detector 1 Queue (s)	0.0	0.0			0.0		0.0	0.0		0.0		0.0
Detector 1 Delay (s)	0.0	0.0			0.0		0.0	0.0		0.0		0.0
Detector 2 Position(ft)		94			94			94				
Detector 2 Size(ft)		6			6			6				
Detector 2 Type		Cl+Ex			Cl+Ex			Cl+Ex				
Detector 2 Channel												
Detector 2 Extend (s)		0.0			0.0			0.0				

Lanes, Volumes, Timings

General Plan 2040 Conditions

10: US 101 NB Off Ramp/Lakewood Drive & Old Redwood Highway Timing Plan: Saturday Midday Peak



Lane Group	EBL	EBT	EBR	WBL	WBT	WBR	NBL	NBT	NBR	SBL	SBT	SBR
Turn Type	Prot	NA			NA		Split	NA		Prot		pm+ov
Protected Phases	5	2			6		8	8		7		5
Permitted Phases												5 8
Detector Phase	5	2			6		8	8		7		5
Switch Phase												
Minimum Initial (s)	7.0	10.0			10.0		10.0	10.0		7.0		7.0
Minimum Split (s)	11.5	32.1			32.1		33.7	33.7		11.5		11.5
Total Split (s)	12.0	45.3			33.3		33.7	33.7		11.5		12.0
Total Split (%)	13.3%	50.1%			36.8%		37.2%	37.2%		12.7%		13.3%
Maximum Green (s)	7.5	40.8			28.8		29.2	29.2		7.0		7.5
Yellow Time (s)	3.5	3.5			3.5		3.5	3.5		3.5		3.5
All-Red Time (s)	1.0	1.0			1.0		1.0	1.0		1.0		1.0
Lost Time Adjust (s)	0.0	0.0			0.0		0.0	0.0		0.0		0.0
Total Lost Time (s)	4.5	4.5			4.5		4.5	4.5		4.5		4.5
Lead/Lag	Lead				Lag		Lag	Lag		Lead		Lead
Lead-Lag Optimize?	Yes				Yes		Yes	Yes		Yes		Yes
Vehicle Extension (s)	3.0	3.0			3.0		3.0	3.0		3.0		3.0
Recall Mode	None	Max			Max		None	None		None		None
Walk Time (s)		7.0			7.0		7.0	7.0				
Flash Don't Walk (s)		20.0			17.0		22.0	22.0				
Pedestrian Calls (#/hr)		0			0		0	0				
Act Effct Green (s)	7.5	41.0			28.9		24.7	24.7		7.0		36.7
Actuated g/C Ratio	0.09	0.48			0.34		0.29	0.29		0.08		0.43
v/c Ratio	1.31	0.48			0.95		0.73	0.70		1.29		1.26
Control Delay (s/veh)	195.7	18.6			42.7		37.9	28.9		188.2		147.3
Queue Delay	0.0	0.0			0.0		0.0	0.0		0.0		0.0
Total Delay (s/veh)	195.7	18.6			42.7		37.9	28.9		188.2		147.3
LOS	F	B			D		D	C		F		F
Approach Delay (s/veh)		103.4			42.7			31.9				157.8
Approach LOS		F			D			C				F

Intersection Summary

Area Type: Other  
 Cycle Length: 90.5  
 Actuated Cycle Length: 86.2  
 Natural Cycle: 100  
 Control Type: Actuated-Uncoordinated  
 Maximum v/c Ratio: 1.31  
 Intersection Signal Delay (s/veh): 88.4  
 Intersection LOS: F  
 Intersection Capacity Utilization 116.4%  
 ICU Level of Service H  
 Analysis Period (min) 15

Splits and Phases: 10: US 101 NB Off Ramp/Lakewood Drive & Old Redwood Highway

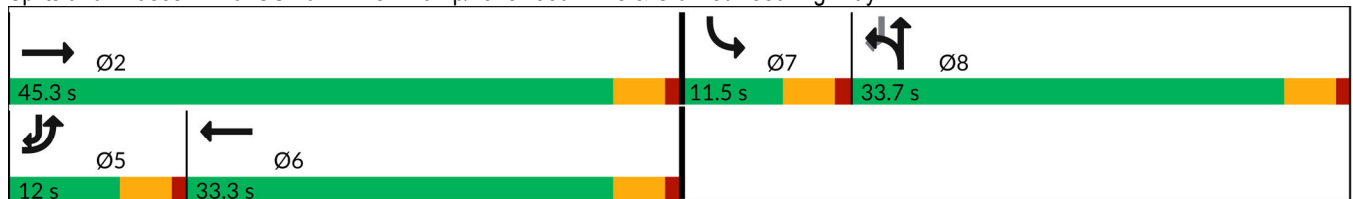

Lanes, Volumes, Timings  
 11: Old Redwood Highway & US 101 NB On Ramp

General Plan 2040 Conditions  
 Timing Plan: Saturday Midday Peak

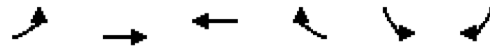

Lane Group	EBL	EBT	WBT	WBR	SBL	SBR
Lane Configurations						
Traffic Volume (vph)	112	784	1698	279	0	0
Future Volume (vph)	112	784	1698	279	0	0
Ideal Flow (vphp)	1900	1900	1900	1900	1900	1900
Storage Length (ft)	245			0	0	0
Storage Lanes	1			0	0	0
Taper Length (ft)	50				25	
Lane Util. Factor	1.00	0.95	0.95	0.95	1.00	1.00
Ped Bike Factor						
Frt			0.979			
Flt Protected	0.950					
Satd. Flow (prot)	1770	3539	3465	0	0	0
Flt Permitted	0.950					
Satd. Flow (perm)	1770	3539	3465	0	0	0
Link Speed (mph)		35	35		30	
Link Distance (ft)		531	226		299	
Travel Time (s)		10.3	4.4		6.8	
Confl. Peds. (#/hr)	8			8		
Confl. Bikes (#/hr)				4		
Peak Hour Factor	0.96	0.96	0.92	0.92	0.25	0.25
Adj. Flow (vph)	117	817	1846	303	0	0
Shared Lane Traffic (%)						
Lane Group Flow (vph)	117	817	2149	0	0	0
Enter Blocked Intersection	No	No	No	No	No	No
Lane Alignment	Left	Left	Left	Right	Left	Right
Median Width(ft)		12	12		0	
Link Offset(ft)		0	0		0	
Crosswalk Width(ft)		16	16		16	
Two way Left Turn Lane						
Headway Factor	1.00	1.00	1.00	1.00	1.00	1.00
Turning Speed (mph)	15			9	15	9
Sign Control		Free	Free		Free	

**Intersection Summary**  
 Area Type: Other  
 Control Type: Unsignalized  
 Intersection Capacity Utilization 89.0% ICU Level of Service E  
 Analysis Period (min) 15

Lanes, Volumes, Timings

General Plan 2040 Conditions

12: US 101 SB On Ramp/US 101 SB Off Ramp & Old Redwood Highway Timing Plan: Saturday Midday Peak



Lane Group	EBL	EBT	EBR	WBL	WBT	WBR	NBL	NBT	NBR	SBL	SBT	SBR
Lane Configurations		↑↑	↗	↘	↑↑					↘	↕	
Traffic Volume (vph)	0	713	543	632	1060	0	0	0	0	196	1	112
Future Volume (vph)	0	713	543	632	1060	0	0	0	0	196	1	112
Ideal Flow (vphpl)	1900	1900	1900	1900	1900	1900	1900	1900	1900	1900	1900	1900
Storage Length (ft)	0		0	250		0	0		0	420		0
Storage Lanes	0		1	0		0	0		0	1		0
Taper Length (ft)	25			165			25			75		
Lane Util. Factor	1.00	0.95	1.00	1.00	0.95	1.00	1.00	1.00	1.00	0.95	0.95	1.00
Ped Bike Factor			0.98	1.00								
Frt			0.850								0.886	
Flt Protected				0.950						0.950	0.988	
Satd. Flow (prot)	0	3539	1583	1770	3539	0	0	0	0	1681	1549	0
Flt Permitted				0.950						0.950	0.988	
Satd. Flow (perm)	0	3539	1553	1769	3539	0	0	0	0	1681	1549	0
Right Turn on Red			Yes			Yes			Yes			Yes
Satd. Flow (RTOR)			409								141	
Link Speed (mph)		35			35			30			30	
Link Distance (ft)		423			531			621			831	
Travel Time (s)		8.2			10.3			14.1			18.9	
Confl. Peds. (#/hr)	11		2	2		11						
Confl. Bikes (#/hr)			10			2						
Peak Hour Factor	0.97	0.97	0.97	0.96	0.96	0.96	0.25	0.25	0.25	0.72	0.72	0.72
Adj. Flow (vph)	0	735	560	658	1104	0	0	0	0	272	1	156
Shared Lane Traffic (%)										18%		
Lane Group Flow (vph)	0	735	560	658	1104	0	0	0	0	223	206	0
Enter Blocked Intersection	No	No	No	No	No	No	No	No	No	No	No	No
Lane Alignment	Left	Left	Right	Left	Left	Right	Left	Left	Right	Left	Left	Right
Median Width(ft)		24			24			12			12	
Link Offset(ft)		0			0			0			0	
Crosswalk Width(ft)		16			16			16			16	
Two way Left Turn Lane												
Headway Factor	1.00	1.00	1.00	1.00	1.00	1.00	1.00	1.00	1.00	1.00	1.00	1.00
Turning Speed (mph)	15		9	15		9	15		9	15		9
Number of Detectors		2	1	1	2					1	2	
Detector Template		Thru	Right	Left	Thru					Left	Thru	
Leading Detector (ft)		100	20	20	100					20	100	
Trailing Detector (ft)		0	0	0	0					0	0	
Detector 1 Position(ft)		0	0	0	0					0	0	
Detector 1 Size(ft)		6	20	20	6					20	6	
Detector 1 Type		Cl+Ex	Cl+Ex	Cl+Ex	Cl+Ex					Cl+Ex	Cl+Ex	
Detector 1 Channel												
Detector 1 Extend (s)		0.0	0.0	0.0	0.0					0.0	0.0	
Detector 1 Queue (s)		0.0	0.0	0.0	0.0					0.0	0.0	
Detector 1 Delay (s)		0.0	0.0	0.0	0.0					0.0	0.0	
Detector 2 Position(ft)		94			94							94
Detector 2 Size(ft)		6			6							6
Detector 2 Type		Cl+Ex			Cl+Ex							Cl+Ex
Detector 2 Channel												
Detector 2 Extend (s)		0.0			0.0							0.0

Lanes, Volumes, Timings

General Plan 2040 Conditions

12: US 101 SB On Ramp/US 101 SB Off Ramp & Old Redwood Highway Timing Plan: Saturday Midday Peak



Lane Group	EBL	EBT	EBR	WBL	WBT	WBR	NBL	NBT	NBR	SBL	SBT	SBR
Turn Type		NA	Perm	Prot	NA					Perm	NA	
Protected Phases		6		5	2						8	
Permitted Phases			6							8		
Detector Phase		6	6	5	2					8	8	
Switch Phase												
Minimum Initial (s)		10.0	10.0	7.0	10.0					10.0	10.0	
Minimum Split (s)		32.1	32.1	11.5	38.1					14.7	14.7	
Total Split (s)		32.3	32.3	23.0	55.3					14.7	14.7	
Total Split (%)		46.1%	46.1%	32.9%	79.0%					21.0%	21.0%	
Maximum Green (s)		27.8	27.8	18.5	50.8					10.2	10.2	
Yellow Time (s)		3.5	3.5	3.5	3.5					3.5	3.5	
All-Red Time (s)		1.0	1.0	1.0	1.0					1.0	1.0	
Lost Time Adjust (s)		0.0	0.0	0.0	0.0					0.0	0.0	
Total Lost Time (s)		4.5	4.5	4.5	4.5					4.5	4.5	
Lead/Lag		Lag	Lag	Lead								
Lead-Lag Optimize?		Yes	Yes	Yes								
Vehicle Extension (s)		3.0	3.0	3.0	3.0					3.0	3.0	
Recall Mode		Max	Max	None	Max					None	None	
Walk Time (s)		7.0	7.0		7.0							
Flash Don't Walk (s)		20.0	20.0		25.0							
Pedestrian Calls (#/hr)		0	0		0							
Act Effct Green (s)		27.8	27.8	18.5	50.8					10.2	10.2	
Actuated g/C Ratio		0.40	0.40	0.26	0.73					0.15	0.15	
v/c Ratio		0.52	0.65	1.41	0.43					0.91	0.60	
Control Delay (s/veh)		17.7	8.7	222.1	4.4					72.4	18.2	
Queue Delay		0.0	0.0	0.0	0.0					0.0	0.0	
Total Delay (s/veh)		17.7	8.7	222.1	4.4					72.4	18.2	
LOS		B	A	F	A					E	B	
Approach Delay (s/veh)		13.8			85.7						46.4	
Approach LOS		B			F						D	

Intersection Summary

Area Type: Other  
 Cycle Length: 70  
 Actuated Cycle Length: 70  
 Natural Cycle: 90  
 Control Type: Actuated-Uncoordinated  
 Maximum v/c Ratio: 1.41  
 Intersection Signal Delay (s/veh): 54.2  
 Intersection LOS: D  
 Intersection Capacity Utilization 89.0%  
 ICU Level of Service E  
 Analysis Period (min) 15

Splits and Phases: 12: US 101 SB On Ramp/US 101 SB Off Ramp & Old Redwood Highway

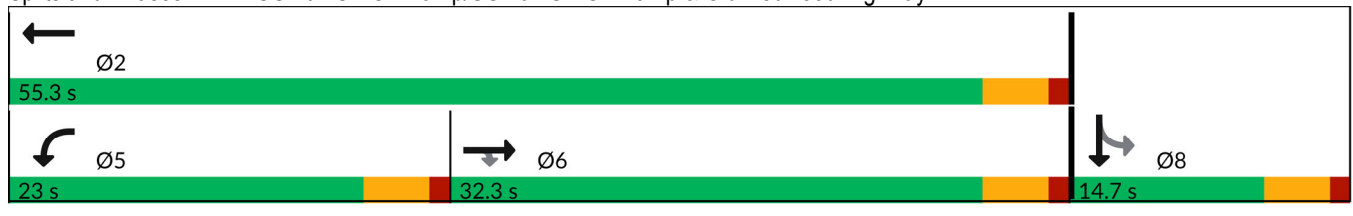























Appendix K – General Plan 2040 plus Alternative A Project  
Conditions Intersection Level of Service Worksheets

---

---

HCM 6th Signalized Intersection Summary  
 1: Old Redwood Hwy & Shiloh Road

General Plan 2040 Project Altern. A Conditions  
 Timing Plan: A.M. PEAK

												
Movement	EBL	EBT	EBR	WBL	WBT	WBR	NBL	NBT	NBR	SBL	SBT	SBR
Lane Configurations												
Traffic Volume (veh/h)	313	310	440	40	242	29	364	312	18	53	479	398
Future Volume (veh/h)	313	310	440	40	242	29	364	312	18	53	479	398
Initial Q (Qb), veh	0	0	0	0	0	0	0	0	0	0	0	0
Ped-Bike Adj(A_pbT)	1.00		1.00	1.00		1.00	1.00		1.00	1.00		0.98
Parking Bus, Adj	1.00	1.00	1.00	1.00	1.00	1.00	1.00	1.00	1.00	1.00	1.00	1.00
Work Zone On Approach		No			No			No			No	
Adj Sat Flow, veh/h/ln	1870	1870	1870	1870	1870	1870	1870	1870	1870	1870	1870	1870
Adj Flow Rate, veh/h	386	383	543	45	272	33	391	335	19	62	564	468
Peak Hour Factor	0.81	0.81	0.81	0.89	0.89	0.89	0.93	0.93	0.93	0.85	0.85	0.85
Percent Heavy Veh, %	2	2	2	2	2	2	2	2	2	2	2	2
Cap, veh/h	451	473	401	52	312	310	214	675	572	89	543	450
Arrive On Green	0.25	0.25	0.25	0.20	0.20	0.20	0.12	0.36	0.36	0.05	0.29	0.29
Sat Flow, veh/h	1781	1870	1585	264	1594	1585	1781	1870	1585	1781	1870	1551
Grp Volume(v), veh/h	386	383	543	317	0	33	391	335	19	62	564	468
Grp Sat Flow(s),veh/h/ln	1781	1870	1585	1857	0	1585	1781	1870	1585	1781	1870	1551
Q Serve(g_s), s	24.9	23.2	30.5	20.0	0.0	2.1	14.5	16.8	0.9	4.1	35.0	35.0
Cycle Q Clear(g_c), s	24.9	23.2	30.5	20.0	0.0	2.1	14.5	16.8	0.9	4.1	35.0	35.0
Prop In Lane	1.00		1.00	0.14		1.00	1.00		1.00	1.00		1.00
Lane Grp Cap(c), veh/h	451	473	401	363	0	310	214	675	572	89	543	450
V/C Ratio(X)	0.86	0.81	1.35	0.87	0.00	0.11	1.83	0.50	0.03	0.70	1.04	1.04
Avail Cap(c_a), veh/h	451	473	401	585	0	500	214	675	572	89	543	450
HCM Platoon Ratio	1.00	1.00	1.00	1.00	1.00	1.00	1.00	1.00	1.00	1.00	1.00	1.00
Upstream Filter(I)	1.00	1.00	1.00	1.00	0.00	1.00	1.00	1.00	1.00	1.00	1.00	1.00
Uniform Delay (d), s/veh	43.0	42.3	45.0	47.0	0.0	39.8	53.0	30.0	24.9	56.4	42.8	42.8
Incr Delay (d2), s/veh	15.0	10.1	175.1	8.3	0.0	0.1	389.2	0.6	0.0	21.6	49.1	53.0
Initial Q Delay(d3),s/veh	0.0	0.0	0.0	0.0	0.0	0.0	0.0	0.0	0.0	0.0	0.0	0.0
%ile BackOfQ(50%),veh/ln	12.6	11.8	31.0	9.9	0.0	0.8	29.5	7.4	0.3	2.4	23.0	19.6
Unsig. Movement Delay, s/veh												
LnGrp Delay(d),s/veh	58.0	52.5	220.1	55.4	0.0	40.0	442.2	30.6	25.0	78.0	91.9	95.8
LnGrp LOS	E	D	F	E	A	D	F	C	C	E	F	F
Approach Vol, veh/h		1312			350			745			1094	
Approach Delay, s/veh		123.5			53.9			246.5			92.8	
Approach LOS		F			D			F			F	
Timer - Assigned Phs		2	3	4		6	7	8				
Phs Duration (G+Y+Rc), s		35.0	18.0	39.5		28.1	9.5	48.0				
Change Period (Y+Rc), s		4.5	3.5	4.5		4.5	3.5	4.5				
Max Green Setting (Gmax), s		30.5	14.5	35.0		38.0	6.0	43.5				
Max Q Clear Time (g_c+I1), s		32.5	16.5	37.0		22.0	6.1	18.8				
Green Ext Time (p_c), s		0.0	0.0	0.0		1.6	0.0	1.8				
<b>Intersection Summary</b>												
HCM 6th Ctrl Delay			133.1									
HCM 6th LOS			F									

HCM 6th Signalized Intersection Summary  
2: Shiloh Road & Hembree Ln

General Plan 2040 Project Altern. A Conditions  
Timing Plan: A.M. PEAK

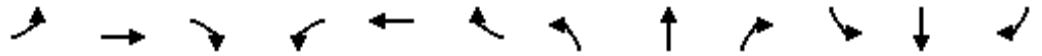

Movement	EBL	EBT	EBR	WBL	WBT	WBR	NBL	NBT	NBR	SBL	SBT	SBR
Lane Configurations	↔↔	↔		↔	↔↔		↔	↔			↔	↔
Traffic Volume (veh/h)	311	918	103	49	865	90	49	11	16	129	18	570
Future Volume (veh/h)	311	918	103	49	865	90	49	11	16	129	18	570
Initial Q (Qb), veh	0	0	0	0	0	0	0	0	0	0	0	0
Ped-Bike Adj(A_pbT)	1.00		1.00	1.00		1.00	1.00		1.00	1.00		1.00
Parking Bus, Adj	1.00	1.00	1.00	1.00	1.00	1.00	1.00	1.00	1.00	1.00	1.00	1.00
Work Zone On Approach		No			No			No			No	
Adj Sat Flow, veh/h/ln	1870	1870	1870	1870	1870	1870	1870	1870	1870	1870	1870	1870
Adj Flow Rate, veh/h	353	1043	103	49	892	93	49	11	16	137	18	606
Peak Hour Factor	0.88	0.88	1.00	1.00	0.97	0.97	1.00	1.00	1.00	0.94	1.00	0.94
Percent Heavy Veh, %	2	2	2	2	2	2	2	2	2	2	2	2
Cap, veh/h	449	1024	101	71	1694	177	86	33	49	183	24	389
Arrive On Green	0.13	0.61	0.61	0.04	0.52	0.52	0.05	0.05	0.05	0.12	0.12	0.12
Sat Flow, veh/h	3456	1675	165	1781	3248	339	1781	689	1002	1583	208	1585
Grp Volume(v), veh/h	353	0	1146	49	488	497	49	0	27	155	0	606
Grp Sat Flow(s),veh/h/ln	1728	0	1841	1781	1777	1809	1781	0	1690	1791	0	1585
Q Serve(g_s), s	8.6	0.0	53.0	2.4	15.7	15.7	2.3	0.0	1.3	7.3	0.0	10.0
Cycle Q Clear(g_c), s	8.6	0.0	53.0	2.4	15.7	15.7	2.3	0.0	1.3	7.3	0.0	10.0
Prop In Lane	1.00		0.09	1.00		0.19	1.00		0.59	0.88		1.00
Lane Grp Cap(c), veh/h	449	0	1126	71	927	944	86	0	82	207	0	389
V/C Ratio(X)	0.79	0.00	1.02	0.69	0.53	0.53	0.57	0.00	0.33	0.75	0.00	1.56
Avail Cap(c_a), veh/h	678	0	1126	113	927	944	113	0	107	207	0	389
HCM Platoon Ratio	1.00	1.00	1.00	1.00	1.00	1.00	1.00	1.00	1.00	1.00	1.00	1.00
Upstream Filter(I)	1.00	0.00	1.00	1.00	1.00	1.00	1.00	0.00	1.00	1.00	0.00	1.00
Uniform Delay (d), s/veh	36.5	0.0	16.8	41.1	13.7	13.7	40.3	0.0	39.9	37.1	0.0	32.7
Incr Delay (d2), s/veh	3.5	0.0	31.4	11.2	0.6	0.5	5.8	0.0	2.3	14.1	0.0	263.8
Initial Q Delay(d3),s/veh	0.0	0.0	0.0	0.0	0.0	0.0	0.0	0.0	0.0	0.0	0.0	0.0
%ile BackOfQ(50%),veh/ln	3.7	0.0	27.3	1.2	5.6	5.7	1.1	0.0	0.6	3.9	0.0	36.4
Unsig. Movement Delay, s/veh												
LnGrp Delay(d),s/veh	40.1	0.0	48.3	52.2	14.2	14.2	46.1	0.0	42.2	51.2	0.0	296.5
LnGrp LOS	D	A	F	D	B	B	D	A	D	D	A	F
Approach Vol, veh/h		1499			1034			76				761
Approach Delay, s/veh		46.3			16.0			44.7				246.6
Approach LOS		D			B			D				F
Timer - Assigned Phs	1	2		4	5	6		8				
Phs Duration (G+Y+Rc), s	7.5	57.0		14.0	15.3	49.2		8.2				
Change Period (Y+Rc), s	4.0	4.0		4.0	4.0	4.0		4.0				
Max Green Setting (Gmax), s	5.5	53.0		10.0	17.0	41.5		5.5				
Max Q Clear Time (g_c+I1), s	4.4	55.0		12.0	10.6	17.7		4.3				
Green Ext Time (p_c), s	0.0	0.0		0.0	0.7	6.4		0.0				
<b>Intersection Summary</b>												
HCM 6th Ctrl Delay				82.2								
HCM 6th LOS				F								



HCM 6th Signalized Intersection Summary  
 3: US 101 NB Off-Ramp & Shiloh Road

General Plan 2040 Project Altern. A Conditions  
 Timing Plan: A.M. PEAK



Movement	EBT	EBR	WBL	WBT	NBL	NBR
Lane Configurations	↑↑			↑	↘	↗
Traffic Volume (veh/h)	732	0	0	1103	813	601
Future Volume (veh/h)	732	0	0	1103	813	601
Initial Q (Qb), veh	0	0	0	0	0	0
Ped-Bike Adj(A_pbT)		1.00	1.00		1.00	1.00
Parking Bus, Adj	1.00	1.00	1.00	1.00	1.00	1.00
Work Zone On Approach	No			No	No	
Adj Sat Flow, veh/h/ln	1870	0	0	1870	1870	1870
Adj Flow Rate, veh/h	804	0	0	1226	1070	791
Peak Hour Factor	0.91	0.91	0.90	0.90	0.76	0.76
Percent Heavy Veh, %	2	0	0	2	2	2
Cap, veh/h	1629	0	0	857	767	1201
Arrive On Green	0.46	0.00	0.00	0.46	0.43	0.43
Sat Flow, veh/h	3741	0	0	1870	1781	2790
Grp Volume(v), veh/h	804	0	0	1226	1070	791
Grp Sat Flow(s),veh/h/ln	1777	0	0	1870	1781	1395
Q Serve(g_s), s	11.4	0.0	0.0	33.0	31.0	16.2
Cycle Q Clear(g_c), s	11.4	0.0	0.0	33.0	31.0	16.2
Prop In Lane		0.00	0.00		1.00	1.00
Lane Grp Cap(c), veh/h	1629	0	0	857	767	1201
V/C Ratio(X)	0.49	0.00	0.00	1.43	1.40	0.66
Avail Cap(c_a), veh/h	1629	0	0	857	767	1201
HCM Platoon Ratio	1.00	1.00	1.00	1.00	1.00	1.00
Upstream Filter(I)	1.00	0.00	0.00	1.00	1.00	1.00
Uniform Delay (d), s/veh	13.7	0.0	0.0	19.5	20.5	16.3
Incr Delay (d2), s/veh	0.2	0.0	0.0	200.3	185.7	1.3
Initial Q Delay(d3),s/veh	0.0	0.0	0.0	0.0	0.0	0.0
%ile BackOfQ(50%),veh/ln	3.9	0.0	0.0	59.5	51.0	4.9
Unsig. Movement Delay, s/veh						
LnGrp Delay(d),s/veh	13.9	0.0	0.0	219.8	206.2	17.6
LnGrp LOS	B	A	A	F	F	B
Approach Vol, veh/h	804			1226	1861	
Approach Delay, s/veh	13.9			219.8	126.1	
Approach LOS	B			F	F	
Timer - Assigned Phs		2			6	8
Phs Duration (G+Y+Rc), s		37.0			37.0	35.0
Change Period (Y+Rc), s		4.0			4.0	4.0
Max Green Setting (Gmax), s		33.0			33.0	31.0
Max Q Clear Time (g_c+I1), s		13.4			35.0	33.0
Green Ext Time (p_c), s		5.2			0.0	0.0
<b>Intersection Summary</b>						
HCM 6th Ctrl Delay			132.4			
HCM 6th LOS			F			

# HCM Signalized Intersection Capacity Analysis General Plan 2040 Project Altern. A Conditions

## 4: Shiloh Road & US 101 SB Off-Ramp

Timing Plan: A.M. PEAK



Movement	EBL	EBT	WBT	WBR	SBL	SBR
Lane Configurations		↑	↑		↘	↗
Traffic Volume (vph)	0	422	1153	0	310	184
Future Volume (vph)	0	422	1153	0	310	184
Ideal Flow (vphpl)	1900	1900	1900	1900	1900	1900
Total Lost time (s)		4.0	4.0		4.0	4.0
Lane Util. Factor		1.00	1.00		1.00	1.00
Frt		1.00	1.00		1.00	0.85
Flt Protected		1.00	1.00		0.95	1.00
Satd. Flow (prot)		1863	1863		1770	1583
Flt Permitted		1.00	1.00		0.95	1.00
Satd. Flow (perm)		1863	1863		1770	1583
Peak-hour factor, PHF	0.93	0.93	0.91	0.91	0.92	0.92
Adj. Flow (vph)	0	454	1267	0	337	200
RTOR Reduction (vph)	0	0	0	0	0	86
Lane Group Flow (vph)	0	454	1267	0	337	114
Turn Type		NA	NA		Perm	Perm
Protected Phases		2	6			
Permitted Phases					4	4
Actuated Green, G (s)		61.3	61.3		17.1	17.1
Effective Green, g (s)		61.3	61.3		17.1	17.1
Actuated g/C Ratio		0.71	0.71		0.20	0.20
Clearance Time (s)		4.0	4.0		4.0	4.0
Vehicle Extension (s)		3.0	3.0		3.0	3.0
Lane Grp Cap (vph)		1321	1321		350	313
v/s Ratio Prot		0.24	c0.68			
v/s Ratio Perm					c0.19	0.07
v/c Ratio		0.34	0.96		0.96	0.36
Uniform Delay, d1		4.8	11.4		34.3	30.0
Progression Factor		1.00	1.00		1.00	1.00
Incremental Delay, d2		0.2	15.8		38.1	0.7
Delay (s)		5.0	27.2		72.4	30.7
Level of Service		A	C		E	C
Approach Delay (s)		5.0	27.2		56.9	
Approach LOS		A	C		E	

### Intersection Summary

HCM 2000 Control Delay	29.8	HCM 2000 Level of Service	C
HCM 2000 Volume to Capacity ratio	0.96		
Actuated Cycle Length (s)	86.4	Sum of lost time (s)	8.0
Intersection Capacity Utilization	145.0%	ICU Level of Service	H
Analysis Period (min)	15		

c Critical Lane Group

Intersection						
Int Delay, s/veh	6					
Movement	EBT	EBR	WBL	WBT	NBL	NBR
Lane Configurations	↑↑		↖	↑	↖	↖
Traffic Vol, veh/h	900	14	130	1207	17	122
Future Vol, veh/h	900	14	130	1207	17	122
Conflicting Peds, #/hr	0	0	0	0	0	0
Sign Control	Free	Free	Free	Free	Stop	Stop
RT Channelized	-	None	-	None	-	None
Storage Length	-	-	68	-	0	0
Veh in Median Storage, #	0	-	-	0	0	-
Grade, %	0	-	-	0	0	-
Peak Hour Factor	96	96	87	87	84	84
Heavy Vehicles, %	2	2	2	2	2	2
Mvmt Flow	938	15	149	1387	20	145

Major/Minor	Major1	Major2	Minor1		
Conflicting Flow All	0	0	953	0	2631 477
Stage 1	-	-	-	-	946 -
Stage 2	-	-	-	-	1685 -
Critical Hdwy	-	-	4.13	-	6.63 6.93
Critical Hdwy Stg 1	-	-	-	-	5.83 -
Critical Hdwy Stg 2	-	-	-	-	5.43 -
Follow-up Hdwy	-	-	2.219	-	3.519 3.319
Pot Cap-1 Maneuver	-	-	719	-	22 535
Stage 1	-	-	-	-	339 -
Stage 2	-	-	-	-	164 -
Platoon blocked, %	-	-	-	-	-
Mov Cap-1 Maneuver	-	-	719	-	~ 17 535
Mov Cap-2 Maneuver	-	-	-	-	~ 17 -
Stage 1	-	-	-	-	339 -
Stage 2	-	-	-	-	130 -



















Approach	EB	WB	NB
HCM Control Delay, s	0	1.1	85.7
HCM LOS			F

Minor Lane/Major Mvmt	NBLn1	NBLn2	EBT	EBR	WBL	WBT
Capacity (veh/h)	17	535	-	-	719	-
HCM Lane V/C Ratio	1.19	0.271	-	-	0.208	-
HCM Control Delay (s)	\$ 599.2	14.2	-	-	11.3	-
HCM Lane LOS	F	B	-	-	B	-
HCM 95th %tile Q(veh)	3	1.1	-	-	0.8	-

Notes  
 ~: Volume exceeds capacity    \$: Delay exceeds 300s    +: Computation Not Defined    \*: All major volume in platoon

HCM Signalized Intersection Capacity Analysis General Plan 2040 Project Altern. A Conditions  
 6: Conde Lane & Shiloh Road

Timing Plan: A.M. PEAK

												
Movement	EBL	EBT	EBR	WBL	WBT	WBR	NBL	NBT	NBR	SBL	SBT	SBR
Lane Configurations												
Traffic Volume (vph)	55	535	3	8	854	298	2	1	9	363	0	27
Future Volume (vph)	55	535	3	8	854	298	2	1	9	363	0	27
Ideal Flow (vphpl)	1900	1900	1900	1900	1900	1900	1900	1900	1900	1900	1900	1900
Total Lost time (s)	4.0	4.0		4.0	4.0			4.0			4.0	4.0
Lane Util. Factor	1.00	0.95		1.00	0.95			1.00			1.00	1.00
Frt	1.00	1.00		1.00	0.96			0.90			1.00	0.85
Flt Protected	0.95	1.00		0.95	1.00			0.99			0.95	1.00
Satd. Flow (prot)	1770	3536		1770	3402			1665			1770	1583
Flt Permitted	0.95	1.00		0.95	1.00			0.99			0.95	1.00
Satd. Flow (perm)	1770	3536		1770	3402			1665			1770	1583
Peak-hour factor, PHF	0.95	0.95	0.95	0.85	0.85	0.85	0.57	0.57	0.57	0.86	0.86	0.86
Adj. Flow (vph)	58	563	3	9	1005	351	4	2	16	422	0	31
RTOR Reduction (vph)	0	0	0	0	22	0	0	15	0	0	0	0
Lane Group Flow (vph)	58	566	0	9	1334	0	0	7	0	0	422	31
Turn Type	Prot	NA		Prot	NA		Split	NA		Split	NA	custom
Protected Phases	5	2		1	6		7	7		4	4	
Permitted Phases												6
Actuated Green, G (s)	4.7	46.9		1.3	43.5			3.4			11.3	43.5
Effective Green, g (s)	4.7	46.9		1.3	43.5			3.4			11.3	43.5
Actuated g/C Ratio	0.06	0.59		0.02	0.55			0.04			0.14	0.55
Clearance Time (s)	4.0	4.0		4.0	4.0			4.0			4.0	4.0
Vehicle Extension (s)	3.0	3.0		3.0	3.0			3.0			3.0	3.0
Lane Grp Cap (vph)	105	2101		29	1875			71			253	872
v/s Ratio Prot	c0.03	c0.16		0.01	c0.39			c0.00			c0.24	
v/s Ratio Perm												0.02
v/c Ratio	0.55	0.27		0.31	0.71			0.09			1.67	0.04
Uniform Delay, d1	36.1	7.7		38.4	13.1			36.3			33.8	8.1
Progression Factor	1.00	1.00		1.00	1.00			1.00			1.00	1.00
Incremental Delay, d2	6.2	0.1		6.0	1.3			0.6			317.4	0.0
Delay (s)	42.2	7.8		44.4	14.4			36.8			351.2	8.1
Level of Service	D	A		D	B			D			F	A
Approach Delay (s)		11.0			14.6			36.8			327.7	
Approach LOS		B			B			D			F	
<b>Intersection Summary</b>												
HCM 2000 Control Delay			71.4									E
HCM 2000 Volume to Capacity ratio			0.82									
Actuated Cycle Length (s)			78.9						16.0			
Intersection Capacity Utilization			76.6%									D
Analysis Period (min)			15									

c Critical Lane Group

Intersection												
Int Delay, s/veh	1.3											
Movement	EBL	EBT	EBR	WBL	WBT	WBR	NBL	NBT	NBR	SBL	SBT	SBR
Lane Configurations		↕	↗		↕		↕	↗			↕	
Traffic Vol, veh/h	12	353	47	0	187	0	33	0	0	1	0	24
Future Vol, veh/h	12	353	47	0	187	0	33	0	0	1	0	24
Conflicting Peds, #/hr	0	0	0	0	0	0	0	0	0	0	0	0
Sign Control	Free	Free	Free	Free	Free	Free	Stop	Stop	Stop	Stop	Stop	Stop
RT Channelized	-	-	None	-	-	None	-	-	None	-	-	None
Storage Length	-	-	150	-	-	-	0	-	-	-	-	-
Veh in Median Storage, #	-	0	-	-	0	-	-	0	-	-	0	-
Grade, %	-	0	-	-	0	-	-	0	-	-	0	-
Peak Hour Factor	91	91	91	85	85	85	100	100	100	71	71	71
Heavy Vehicles, %	2	2	2	2	2	2	2	2	2	2	2	2
Mvmt Flow	13	388	52	0	220	0	33	0	0	1	0	34

Major/Minor	Major1			Major2			Minor1			Minor2		
Conflicting Flow All	220	0	0	440	0	0	651	634	388	660	686	220
Stage 1	-	-	-	-	-	-	414	414	-	220	220	-
Stage 2	-	-	-	-	-	-	237	220	-	440	466	-
Critical Hdwy	4.12	-	-	4.12	-	-	7.12	6.52	6.22	7.12	6.52	6.22
Critical Hdwy Stg 1	-	-	-	-	-	-	6.12	5.52	-	6.12	5.52	-
Critical Hdwy Stg 2	-	-	-	-	-	-	6.12	5.52	-	6.12	5.52	-
Follow-up Hdwy	2.218	-	-	2.218	-	-	3.518	4.018	3.318	3.518	4.018	3.318
Pot Cap-1 Maneuver	1349	-	-	1120	-	-	382	397	660	376	370	820
Stage 1	-	-	-	-	-	-	616	593	-	782	721	-
Stage 2	-	-	-	-	-	-	766	721	-	596	562	-
Platoon blocked, %	-	-	-	-	-	-	-	-	-	-	-	-
Mov Cap-1 Maneuver	1349	-	-	1120	-	-	363	392	660	372	365	820
Mov Cap-2 Maneuver	-	-	-	-	-	-	363	392	-	372	365	-
Stage 1	-	-	-	-	-	-	608	585	-	772	721	-
Stage 2	-	-	-	-	-	-	734	721	-	588	555	-

Approach	EB	WB	NB	SB
HCM Control Delay, s	0.2	0	15.9	9.8
HCM LOS			C	A

Minor Lane/Major Mvmt	NBLn1	NBLn2	EBL	EBT	EBR	WBL	WBT	WBR	SBLn1
Capacity (veh/h)	363	-	1349	-	-	1120	-	-	782
HCM Lane V/C Ratio	0.091	-	0.01	-	-	-	-	-	0.045
HCM Control Delay (s)	15.9	0	7.7	0	-	0	-	-	9.8
HCM Lane LOS	C	A	A	A	-	A	-	-	A
HCM 95th %tile Q(veh)	0.3	-	0	-	-	0	-	-	0.1

Intersection												
Int Delay, s/veh	1.6											
Movement	EBL	EBT	EBR	WBL	WBT	WBR	NBL	NBT	NBR	SBL	SBT	SBR
Lane Configurations		↕		↕	↕			↕	↕	↕	↕	
Traffic Vol, veh/h	1	0	0	19	0	31	0	662	28	45	914	0
Future Vol, veh/h	1	0	0	19	0	31	0	662	28	45	914	0
Conflicting Peds, #/hr	0	0	0	0	0	0	0	0	1	1	0	0
Sign Control	Stop	Stop	Stop	Stop	Stop	Stop	Free	Free	Free	Free	Free	Free
RT Channelized	-	-	None	-	-	None	-	-	None	-	-	None
Storage Length	-	-	-	0	-	-	-	-	100	50	-	-
Veh in Median Storage, #	-	0	-	-	0	-	-	0	-	-	0	-
Grade, %	-	0	-	-	0	-	-	0	-	-	0	-
Peak Hour Factor	25	25	25	100	100	100	99	99	99	90	90	90
Heavy Vehicles, %	2	2	2	2	2	2	2	2	2	2	2	2
Mvmt Flow	4	0	0	19	0	31	0	669	28	50	1016	0

Major/Minor	Minor2		Minor1		Major1		Major2					
Conflicting Flow All	1815	1814	1016	1786	1786	670	1016	0	0	698	0	0
Stage 1	1116	1116	-	670	670	-	-	-	-	-	-	-
Stage 2	699	698	-	1116	1116	-	-	-	-	-	-	-
Critical Hdwy	7.12	6.52	6.22	7.12	6.52	6.22	4.12	-	-	4.12	-	-
Critical Hdwy Stg 1	6.12	5.52	-	6.12	5.52	-	-	-	-	-	-	-
Critical Hdwy Stg 2	6.12	5.52	-	6.12	5.52	-	-	-	-	-	-	-
Follow-up Hdwy	3.518	4.018	3.318	3.518	4.018	3.318	2.218	-	-	2.218	-	-
Pot Cap-1 Maneuver	60	78	289	63	81	457	683	-	-	898	-	-
Stage 1	252	283	-	446	455	-	-	-	-	-	-	-
Stage 2	430	442	-	252	283	-	-	-	-	-	-	-
Platoon blocked, %								-	-	-	-	-
Mov Cap-1 Maneuver	54	74	289	60	76	457	683	-	-	897	-	-
Mov Cap-2 Maneuver	54	74	-	60	76	-	-	-	-	-	-	-
Stage 1	252	267	-	446	455	-	-	-	-	-	-	-
Stage 2	401	442	-	238	267	-	-	-	-	-	-	-

Approach	EB		WB		NB		SB	
HCM Control Delay, s	76.9		42.8		0		0.4	
HCM LOS	F		E					

Minor Lane/Major Mvmt	NBL	NBT	NBR	EBLn1	WBLn1	WBLn2	SBL	SBT	SBR
Capacity (veh/h)	683	-	-	54	60	457	897	-	-
HCM Lane V/C Ratio	-	-	-	0.074	0.317	0.068	0.056	-	-
HCM Control Delay (s)	0	-	-	76.9	90.7	13.5	9.2	-	-
HCM Lane LOS	A	-	-	F	F	B	A	-	-
HCM 95th %tile Q(veh)	0	-	-	0.2	1.1	0.2	0.2	-	-

Intersection						
Int Delay, s/veh	2.3					
Movement	EBT	EBR	WBL	WBT	NBL	NBR
Lane Configurations	↑	↗		↖	↖	↗
Traffic Vol, veh/h	207	145	14	77	101	10
Future Vol, veh/h	207	145	14	77	101	10
Conflicting Peds, #/hr	0	0	0	0	0	0
Sign Control	Free	Free	Free	Free	Stop	Stop
RT Channelized	-	None	-	None	-	None
Storage Length	-	200	-	-	0	0
Veh in Median Storage, #	0	-	-	0	0	-
Grade, %	0	-	-	0	0	-
Peak Hour Factor	85	85	81	81	100	100
Heavy Vehicles, %	2	2	2	2	2	2
Mvmt Flow	244	171	17	95	101	10

Major/Minor	Major1	Major2	Minor1		
Conflicting Flow All	0	0	415	0	373 244
Stage 1	-	-	-	-	244 -
Stage 2	-	-	-	-	129 -
Critical Hdwy	-	-	4.12	-	6.42 6.22
Critical Hdwy Stg 1	-	-	-	-	5.42 -
Critical Hdwy Stg 2	-	-	-	-	5.42 -
Follow-up Hdwy	-	-	2.218	-	3.518 3.318
Pot Cap-1 Maneuver	-	-	1144	-	628 795
Stage 1	-	-	-	-	797 -
Stage 2	-	-	-	-	897 -
Platoon blocked, %	-	-	-	-	-
Mov Cap-1 Maneuver	-	-	1144	-	618 795
Mov Cap-2 Maneuver	-	-	-	-	618 -
Stage 1	-	-	-	-	797 -
Stage 2	-	-	-	-	883 -

Approach	EB	WB	NB
HCM Control Delay, s	0	1.3	11.8
HCM LOS			B

Minor Lane/Major Mvmt	NBLn1	NBLn2	EBT	EBR	WBL	WBT
Capacity (veh/h)	618	795	-	-	1144	-
HCM Lane V/C Ratio	0.163	0.013	-	-	0.015	-
HCM Control Delay (s)	12	9.6	-	-	8.2	0
HCM Lane LOS	B	A	-	-	A	A
HCM 95th %tile Q(veh)	0.6	0	-	-	0	-

HCM 6th Signalized Intersection Summary      General Plan 2040 Project Altern. A Conditions  
 10: US 101 NB Off Ramp/Lakewood Drive & Old Redwood Highway      Timing Plan: A.M. PEAK

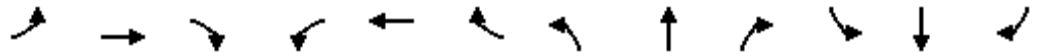

Movement	EBL	EBT	EBR	WBL	WBT	WBR	NBL	NBT	NBR	SBL	SBT	SBR
Lane Configurations	↔↔	↑			↑↑		↔	↔↔		↔↔		↔
Traffic Volume (veh/h)	264	638	0	0	669	156	224	255	92	255	0	679
Future Volume (veh/h)	264	638	0	0	669	156	224	255	92	255	0	679
Initial Q (Qb), veh	0	0	0	0	0	0	0	0	0	0	0	0
Ped-Bike Adj(A_pbT)	1.00		1.00	1.00		0.99	1.00		1.00	1.00		1.00
Parking Bus, Adj	1.00	1.00	1.00	1.00	1.00	1.00	1.00	1.00	1.00	1.00	1.00	1.00
Work Zone On Approach		No			No			No			No	
Adj Sat Flow, veh/h/ln	1870	1870	0	0	1870	1870	1870	1870	1870	1870	0	1870
Adj Flow Rate, veh/h	311	751	0	0	806	188	211	336	102	287	0	0
Peak Hour Factor	0.85	0.85	0.85	0.83	0.83	0.83	0.90	0.90	0.90	0.89	0.89	0.89
Percent Heavy Veh, %	2	2	0	0	2	2	2	2	2	2	0	2
Cap, veh/h	419	1202	0	0	1304	304	358	555	166	0	0	0
Arrive On Green	0.12	0.64	0.00	0.00	0.46	0.46	0.20	0.20	0.20	0.00	0.00	0.00
Sat Flow, veh/h	3456	1870	0	0	2945	665	1781	2764	825		0	
Grp Volume(v), veh/h	311	751	0	0	502	492	211	226	212		0.0	
Grp Sat Flow(s),veh/h/ln	1728	1870	0	0	1777	1740	1781	1870	1719			
Q Serve(g_s), s	5.4	15.0	0.0	0.0	13.4	13.4	6.7	6.9	7.1			
Cycle Q Clear(g_c), s	5.4	15.0	0.0	0.0	13.4	13.4	6.7	6.9	7.1			
Prop In Lane	1.00		0.00	0.00		0.38	1.00		0.48			
Lane Grp Cap(c), veh/h	419	1202	0	0	813	796	358	375	345			
V/C Ratio(X)	0.74	0.62	0.00	0.00	0.62	0.62	0.59	0.60	0.62			
Avail Cap(c_a), veh/h	497	1202	0	0	813	796	826	867	797			
HCM Platoon Ratio	1.00	1.00	1.00	1.00	1.00	1.00	1.00	1.00	1.00			
Upstream Filter(I)	1.00	1.00	0.00	0.00	1.00	1.00	1.00	1.00	1.00			
Uniform Delay (d), s/veh	26.5	6.7	0.0	0.0	12.8	12.8	22.7	22.7	22.8			
Incr Delay (d2), s/veh	4.9	2.5	0.0	0.0	3.5	3.6	1.6	1.5	1.8			
Initial Q Delay(d3),s/veh	0.0	0.0	0.0	0.0	0.0	0.0	0.0	0.0	0.0			
%ile BackOfQ(50%),veh/ln	2.4	4.7	0.0	0.0	5.2	5.1	2.8	3.0	2.8			
Unsig. Movement Delay, s/veh												
LnGrp Delay(d),s/veh	31.4	9.1	0.0	0.0	16.3	16.4	24.2	24.3	24.6			
LnGrp LOS	C	A	A	A	B	B	C	C	C			
Approach Vol, veh/h		1062			994			649				
Approach Delay, s/veh		15.7			16.4			24.4				
Approach LOS		B			B			C				
Timer - Assigned Phs		2			5	6		8				
Phs Duration (G+Y+Rc), s		45.3			11.6	33.7		17.3				
Change Period (Y+Rc), s		5.1			4.0	5.1		4.7				
Max Green Setting (Gmax), s		40.2			9.0	27.2		29.0				
Max Q Clear Time (g_c+I1), s		17.0			7.4	15.4		9.1				
Green Ext Time (p_c), s		5.5			0.2	4.9		3.2				

**Intersection Summary**

HCM 6th Ctrl Delay	18.0
HCM 6th LOS	B

**Notes**

User approved volume balancing among the lanes for turning movement.  
 Unsignalized Delay for [SBR] is excluded from calculations of the approach delay and intersection delay.



HCM 6th Signalized Intersection Summary      General Plan 2040 Project Altern. A Conditions  
 12: US 101 SB On Ramp/US 101 SB Off Ramp & Old Redwood Highway      Timing Plan: A.M. PEAK



Movement	EBL	EBT	EBR	WBL	WBT	WBR	NBL	NBT	NBR	SBL	SBT	SBR
Lane Configurations		↑↑	↗	↘	↑↑					↘	↕	
Traffic Volume (veh/h)	0	699	814	559	742	0	0	0	0	185	0	144
Future Volume (veh/h)	0	699	814	559	742	0	0	0	0	185	0	144
Initial Q (Qb), veh	0	0	0	0	0	0				0	0	0
Ped-Bike Adj(A_pbT)	1.00		0.98	1.00		1.00				1.00		1.00
Parking Bus, Adj	1.00	1.00	1.00	1.00	1.00	1.00				1.00	1.00	1.00
Work Zone On Approach		No			No						No	
Adj Sat Flow, veh/h/ln	0	1870	1870	1870	1870	0				1870	1870	1870
Adj Flow Rate, veh/h	0	760	885	628	834	0				203	35	0
Peak Hour Factor	0.92	0.92	0.92	0.89	0.89	0.89				0.81	0.81	0.81
Percent Heavy Veh, %	0	2	2	2	2	0				2	2	2
Cap, veh/h	0	1208	530	646	2674	0				223	234	
Arrive On Green	0.00	0.34	0.34	0.36	0.75	0.00				0.13	0.13	0.00
Sat Flow, veh/h	0	3647	1560	1781	3647	0				1781	1870	0
Grp Volume(v), veh/h	0	760	885	628	834	0				203	35	0
Grp Sat Flow(s),veh/h/ln	0	1777	1560	1781	1777	0				1781	1870	0
Q Serve(g_s), s	0.0	14.4	27.2	27.8	6.1	0.0				9.0	1.3	0.0
Cycle Q Clear(g_c), s	0.0	14.4	27.2	27.8	6.1	0.0				9.0	1.3	0.0
Prop In Lane	0.00		1.00	1.00		0.00				1.00		0.00
Lane Grp Cap(c), veh/h	0	1208	530	646	2674	0				223	234	
V/C Ratio(X)	0.00	0.63	1.67	0.97	0.31	0.00				0.91	0.15	
Avail Cap(c_a), veh/h	0	1208	530	646	2674	0				223	234	
HCM Platoon Ratio	1.00	1.00	1.00	1.00	1.00	1.00				1.00	1.00	1.00
Upstream Filter(I)	0.00	1.00	1.00	1.00	1.00	0.00				1.00	1.00	0.00
Uniform Delay (d), s/veh	0.0	22.2	26.4	25.1	3.2	0.0				34.6	31.2	0.0
Incr Delay (d2), s/veh	0.0	2.5	309.2	28.5	0.3	0.0				37.2	0.3	0.0
Initial Q Delay(d3),s/veh	0.0	0.0	0.0	0.0	0.0	0.0				0.0	0.0	0.0
%ile BackOfQ(50%),veh/ln	0.0	6.0	54.8	15.8	1.4	0.0				6.1	0.6	0.0
Unsig. Movement Delay, s/veh												
LnGrp Delay(d),s/veh	0.0	24.7	335.6	53.7	3.5	0.0				71.7	31.5	0.0
LnGrp LOS	A	C	F	D	A	A				E	C	
Approach Vol, veh/h		1645			1462						238	
Approach Delay, s/veh		191.9			25.0						65.8	
Approach LOS		F			C						E	
Timer - Assigned Phs		2			5	6		8				
Phs Duration (G+Y+Rc), s		65.3			33.0	32.3		14.7				
Change Period (Y+Rc), s		5.1			4.0	5.1		4.7				
Max Green Setting (Gmax), s		60.2			29.0	27.2		10.0				
Max Q Clear Time (g_c+I1), s		8.1			29.8	29.2		11.0				
Green Ext Time (p_c), s		6.9			0.0	0.0		0.0				

**Intersection Summary**























HCM 6th Ctrl Delay	110.0
HCM 6th LOS	F

**Notes**

- User approved volume balancing among the lanes for turning movement.
- User approved ignoring U-Turning movement.
- Unsignalized Delay for [SBR] is excluded from calculations of the approach delay and intersection delay.





















HCM 6th Signalized Intersection Summary  
 1: Old Redwood Hwy & Shiloh Road

General Plan 2040 Project Altern. A Conditions  
 Timing Plan: P.M. Peak

												
Movement	EBL	EBT	EBR	WBL	WBT	WBR	NBL	NBT	NBR	SBL	SBT	SBR
Lane Configurations												
Traffic Volume (veh/h)	317	558	672	44	442	70	667	567	44	100	550	265
Future Volume (veh/h)	317	558	672	44	442	70	667	567	44	100	550	265
Initial Q (Qb), veh	0	0	0	0	0	0	0	0	0	0	0	0
Ped-Bike Adj(A_pbT)	1.00		1.00	1.00		1.00	1.00		0.98	1.00		0.97
Parking Bus, Adj	1.00	1.00	1.00	1.00	1.00	1.00	1.00	1.00	1.00	1.00	1.00	1.00
Work Zone On Approach		No			No			No			No	
Adj Sat Flow, veh/h/ln	1870	1870	1870	1870	1870	1870	1870	1870	1870	1870	1870	1870
Adj Flow Rate, veh/h	327	575	693	48	486	77	717	610	47	108	591	285
Peak Hour Factor	0.97	0.97	0.97	0.91	0.91	0.91	0.93	0.93	0.93	0.93	0.93	0.93
Percent Heavy Veh, %	2	2	2	2	2	2	2	2	2	2	2	2
Cap, veh/h	402	423	357	47	477	445	191	603	498	79	485	400
Arrive On Green	0.23	0.23	0.23	0.28	0.28	0.28	0.11	0.32	0.32	0.04	0.26	0.26
Sat Flow, veh/h	1781	1870	1582	167	1695	1582	1781	1870	1545	1781	1870	1544
Grp Volume(v), veh/h	327	575	693	534	0	77	717	610	47	108	591	285
Grp Sat Flow(s),veh/h/ln	1781	1870	1582	1862	0	1582	1781	1870	1545	1781	1870	1544
Q Serve(g_s), s	23.5	30.5	30.5	38.0	0.0	5.0	14.5	43.5	2.9	6.0	35.0	22.6
Cycle Q Clear(g_c), s	23.5	30.5	30.5	38.0	0.0	5.0	14.5	43.5	2.9	6.0	35.0	22.6
Prop In Lane	1.00		1.00	0.09		1.00	1.00		1.00	1.00		1.00
Lane Grp Cap(c), veh/h	402	423	357	524	0	445	191	603	498	79	485	400
V/C Ratio(X)	0.81	1.36	1.94	1.02	0.00	0.17	3.75	1.01	0.09	1.36	1.22	0.71
Avail Cap(c_a), veh/h	402	423	357	524	0	445	191	603	498	79	485	400
HCM Platoon Ratio	1.00	1.00	1.00	1.00	1.00	1.00	1.00	1.00	1.00	1.00	1.00	1.00
Upstream Filter(I)	1.00	1.00	1.00	1.00	0.00	1.00	1.00	1.00	1.00	1.00	1.00	1.00
Uniform Delay (d), s/veh	49.5	52.2	52.2	48.5	0.0	36.6	60.3	45.8	32.0	64.5	50.0	45.4
Incr Delay (d2), s/veh	12.0	177.1	432.9	44.2	0.0	0.2	1249.1	39.7	0.1	225.7	116.0	5.8
Initial Q Delay(d3),s/veh	0.0	0.0	0.0	0.0	0.0	0.0	0.0	0.0	0.0	0.0	0.0	0.0
%ile BackOfQ(50%),veh/ln	11.6	34.8	54.7	23.6	0.0	1.9	72.8	26.1	1.1	7.7	31.6	9.2
Unsig. Movement Delay, s/veh												
LnGrp Delay(d),s/veh	61.5	229.3	485.2	92.7	0.0	36.8	1309.4	85.5	32.1	290.2	166.0	51.3
LnGrp LOS	E	F	F	F	A	D	F	F	C	F	F	D
Approach Vol, veh/h		1595			611			1374			984	
Approach Delay, s/veh		306.1			85.6			722.3			146.4	
Approach LOS		F			F			F			F	
Timer - Assigned Phs		2	3	4		6	7	8				
Phs Duration (G+Y+Rc), s		35.0	18.0	39.5		42.5	9.5	48.0				
Change Period (Y+Rc), s		4.5	3.5	4.5		4.5	3.5	4.5				
Max Green Setting (Gmax), s		30.5	14.5	35.0		38.0	6.0	43.5				
Max Q Clear Time (g_c+I1), s		32.5	16.5	37.0		40.0	8.0	45.5				
Green Ext Time (p_c), s		0.0	0.0	0.0		0.0	0.0	0.0				
<b>Intersection Summary</b>												
HCM 6th Ctrl Delay			367.4									
HCM 6th LOS			F									

HCM 6th Signalized Intersection Summary  
2: Shiloh Road & Hembree Ln

General Plan 2040 Project Altern. A Conditions  
Timing Plan: P.M. Peak

												
Movement	EBL	EBT	EBR	WBL	WBT	WBR	NBL	NBT	NBR	SBL	SBT	SBR
Lane Configurations												
Traffic Volume (veh/h)	661	1344	69	110	1146	118	111	21	128	174	11	526
Future Volume (veh/h)	661	1344	69	110	1146	118	111	21	128	174	11	526
Initial Q (Qb), veh	0	0	0	0	0	0	0	0	0	0	0	0
Ped-Bike Adj(A_pbT)	1.00		1.00	1.00		1.00	1.00		1.00	1.00		1.00
Parking Bus, Adj	1.00	1.00	1.00	1.00	1.00	1.00	1.00	1.00	1.00	1.00	1.00	1.00
Work Zone On Approach		No			No			No			No	
Adj Sat Flow, veh/h/ln	1870	1870	1870	1870	1870	1870	1870	1870	1870	1870	1870	1870
Adj Flow Rate, veh/h	703	1430	69	110	1317	136	111	21	128	183	11	554
Peak Hour Factor	0.94	0.94	1.00	1.00	0.87	0.87	1.00	1.00	1.00	0.95	1.00	0.95
Percent Heavy Veh, %	2	2	2	2	2	2	2	2	2	2	2	2
Cap, veh/h	653	1042	50	109	1500	154	109	14	85	187	11	476
Arrive On Green	0.19	0.59	0.59	0.06	0.46	0.46	0.06	0.06	0.06	0.11	0.11	0.11
Sat Flow, veh/h	3456	1770	85	1781	3252	334	1781	228	1392	1685	101	1585
Grp Volume(v), veh/h	703	0	1499	110	717	736	111	0	149	194	0	554
Grp Sat Flow(s),veh/h/ln	1728	0	1855	1781	1777	1810	1781	0	1620	1786	0	1585
Q Serve(g_s), s	17.0	0.0	53.0	5.5	32.8	33.2	5.5	0.0	5.5	9.7	0.0	10.0
Cycle Q Clear(g_c), s	17.0	0.0	53.0	5.5	32.8	33.2	5.5	0.0	5.5	9.7	0.0	10.0
Prop In Lane	1.00		0.05	1.00		0.18	1.00		0.86	0.94		1.00
Lane Grp Cap(c), veh/h	653	0	1092	109	819	834	109	0	99	198	0	476
V/C Ratio(X)	1.08	0.00	1.37	1.01	0.88	0.88	1.02	0.00	1.51	0.98	0.00	1.17
Avail Cap(c_a), veh/h	653	0	1092	109	819	834	109	0	99	198	0	476
HCM Platoon Ratio	1.00	1.00	1.00	1.00	1.00	1.00	1.00	1.00	1.00	1.00	1.00	1.00
Upstream Filter(I)	1.00	0.00	1.00	1.00	1.00	1.00	1.00	0.00	1.00	1.00	0.00	1.00
Uniform Delay (d), s/veh	36.5	0.0	18.5	42.3	21.9	22.0	42.3	0.0	42.3	39.9	0.0	31.5
Incr Delay (d2), s/veh	57.8	0.0	173.4	89.1	10.4	10.9	91.6	0.0	272.5	57.2	0.0	95.1
Initial Q Delay(d3),s/veh	0.0	0.0	0.0	0.0	0.0	0.0	0.0	0.0	0.0	0.0	0.0	0.0
%ile BackOfQ(50%),veh/ln	12.1	0.0	71.0	5.0	14.5	15.1	5.2	0.0	9.7	7.3	0.0	22.5
Unsig. Movement Delay, s/veh												
LnGrp Delay(d),s/veh	94.3	0.0	191.9	131.4	32.3	32.9	133.9	0.0	314.8	97.1	0.0	126.6
LnGrp LOS	F	A	F	F	C	C	F	A	F	F	A	F
Approach Vol, veh/h		2202			1563			260			748	
Approach Delay, s/veh		160.7			39.6			237.5			119.0	
Approach LOS		F			D			F			F	
Timer - Assigned Phs	1	2		4	5	6		8				
Phs Duration (G+Y+Rc), s	9.5	57.0		14.0	21.0	45.5		9.5				
Change Period (Y+Rc), s	4.0	4.0		4.0	4.0	4.0		4.0				
Max Green Setting (Gmax), s	5.5	53.0		10.0	17.0	41.5		5.5				
Max Q Clear Time (g_c+I1), s	7.5	55.0		12.0	19.0	35.2		7.5				
Green Ext Time (p_c), s	0.0	0.0		0.0	0.0	4.3		0.0				
<b>Intersection Summary</b>												
HCM 6th Ctrl Delay	118.7											
HCM 6th LOS	F											

HCM 6th Signalized Intersection Summary  
3: US 101 NB Off-Ramp & Shiloh Road

General Plan 2040 Project Altern. A Conditions  
Timing Plan: P.M. Peak



Movement	EBT	EBR	WBL	WBT	NBL	NBR
Lane Configurations	↑↑			↑	↘	↗
Traffic Volume (veh/h)	974	0	0	1119	694	1057
Future Volume (veh/h)	974	0	0	1119	694	1057
Initial Q (Qb), veh	0	0	0	0	0	0
Ped-Bike Adj(A_pbT)		1.00	1.00		1.00	1.00
Parking Bus, Adj	1.00	1.00	1.00	1.00	1.00	1.00
Work Zone On Approach	No			No	No	
Adj Sat Flow, veh/h/ln	1870	0	0	1870	1870	1870
Adj Flow Rate, veh/h	1036	0	0	1154	771	1174
Peak Hour Factor	0.94	0.94	0.97	0.97	0.90	0.90
Percent Heavy Veh, %	2	0	0	2	2	2
Cap, veh/h	1629	0	0	857	767	1201
Arrive On Green	0.46	0.00	0.00	0.46	0.43	0.43
Sat Flow, veh/h	3741	0	0	1870	1781	2790
Grp Volume(v), veh/h	1036	0	0	1154	771	1174
Grp Sat Flow(s),veh/h/ln	1777	0	0	1870	1781	1395
Q Serve(g_s), s	16.0	0.0	0.0	33.0	31.0	29.8
Cycle Q Clear(g_c), s	16.0	0.0	0.0	33.0	31.0	29.8
Prop In Lane		0.00	0.00		1.00	1.00
Lane Grp Cap(c), veh/h	1629	0	0	857	767	1201
V/C Ratio(X)	0.64	0.00	0.00	1.35	1.01	0.98
Avail Cap(c_a), veh/h	1629	0	0	857	767	1201
HCM Platoon Ratio	1.00	1.00	1.00	1.00	1.00	1.00
Upstream Filter(I)	1.00	0.00	0.00	1.00	1.00	1.00
Uniform Delay (d), s/veh	14.9	0.0	0.0	19.5	20.5	20.2
Incr Delay (d2), s/veh	0.8	0.0	0.0	163.6	33.8	20.6
Initial Q Delay(d3),s/veh	0.0	0.0	0.0	0.0	0.0	0.0
%ile BackOfQ(50%),veh/ln	5.7	0.0	0.0	50.8	18.6	12.1
Unsig. Movement Delay, s/veh						
LnGrp Delay(d),s/veh	15.7	0.0	0.0	183.1	54.3	40.8
LnGrp LOS	B	A	A	F	F	D
Approach Vol, veh/h	1036			1154	1945	
Approach Delay, s/veh	15.7			183.1	46.1	
Approach LOS	B			F	D	
Timer - Assigned Phs		2			6	8
Phs Duration (G+Y+Rc), s		37.0			37.0	35.0
Change Period (Y+Rc), s		4.0			4.0	4.0
Max Green Setting (Gmax), s		33.0			33.0	31.0
Max Q Clear Time (g_c+I1), s		18.0			35.0	33.0
Green Ext Time (p_c), s		6.1			0.0	0.0
<b>Intersection Summary</b>						
HCM 6th Ctrl Delay			76.7			
HCM 6th LOS			E			

HCM Signalized Intersection Capacity Analysis General Plan 2040 Project Altern. A Conditions  
 4: Shiloh Road & US 101 SB Off-Ramp

Timing Plan: P.M. Peak



Movement	EBL	EBT	WBT	WBR	SBL	SBR
Lane Configurations		↑	↑		↙	↗
Traffic Volume (vph)	0	672	1084	0	500	94
Future Volume (vph)	0	672	1084	0	500	94
Ideal Flow (vphpl)	1900	1900	1900	1900	1900	1900
Total Lost time (s)		4.0	4.0		4.0	4.0
Lane Util. Factor		1.00	1.00		1.00	1.00
Frbp, ped/bikes		1.00	1.00		1.00	0.98
Flpb, ped/bikes		1.00	1.00		1.00	1.00
Frt		1.00	1.00		1.00	0.85
Flt Protected		1.00	1.00		0.95	1.00
Satd. Flow (prot)		1863	1863		1770	1548
Flt Permitted		1.00	1.00		0.95	1.00
Satd. Flow (perm)		1863	1863		1770	1548
Peak-hour factor, PHF	0.89	0.89	0.96	0.96	0.93	0.93
Adj. Flow (vph)	0	755	1129	0	538	101
RTOR Reduction (vph)	0	0	0	0	0	78
Lane Group Flow (vph)	0	755	1129	0	538	23
Confl. Peds. (#/hr)						1
Turn Type		NA	NA		Perm	Perm
Protected Phases		2	6			
Permitted Phases					4	4
Actuated Green, G (s)		50.9	50.9		17.5	17.5
Effective Green, g (s)		50.9	50.9		17.5	17.5
Actuated g/C Ratio		0.67	0.67		0.23	0.23
Clearance Time (s)		4.0	4.0		4.0	4.0
Vehicle Extension (s)		3.0	3.0		3.0	3.0
Lane Grp Cap (vph)		1241	1241		405	354
v/s Ratio Prot		0.41	c0.61			
v/s Ratio Perm					c0.30	0.01
v/c Ratio		0.61	0.91		1.33	0.07
Uniform Delay, d1		7.2	10.8		29.5	23.0
Progression Factor		1.00	1.00		1.00	1.00
Incremental Delay, d2		0.9	9.9		164.0	0.1
Delay (s)		8.0	20.7		193.4	23.1
Level of Service		A	C		F	C
Approach Delay (s)		8.0	20.7		166.5	
Approach LOS		A	C		F	
<b>Intersection Summary</b>						
HCM 2000 Control Delay			53.8		HCM 2000 Level of Service	D
HCM 2000 Volume to Capacity ratio			1.02			
Actuated Cycle Length (s)			76.4		Sum of lost time (s)	8.0
Intersection Capacity Utilization			176.9%		ICU Level of Service	H
Analysis Period (min)			15			
c Critical Lane Group						

Intersection						
Int Delay, s/veh	8.5					
Movement	EBT	EBR	WBL	WBT	NBL	NBR
Lane Configurations	↑↑		↖	↑	↖	↖
Traffic Vol, veh/h	1214	16	105	1143	18	159
Future Vol, veh/h	1214	16	105	1143	18	159
Conflicting Peds, #/hr	0	0	0	0	0	0
Sign Control	Free	Free	Free	Free	Stop	Stop
RT Channelized	-	None	-	None	-	None
Storage Length	-	-	68	-	0	0
Veh in Median Storage, #	0	-	-	0	0	-
Grade, %	0	-	-	0	0	-
Peak Hour Factor	89	89	92	92	89	89
Heavy Vehicles, %	2	2	2	2	2	2
Mvmt Flow	1364	18	114	1242	20	179

Major/Minor	Major1	Major2	Minor1		
Conflicting Flow All	0	0	1382	0	2843 691
Stage 1	-	-	-	-	1373 -
Stage 2	-	-	-	-	1470 -
Critical Hdwy	-	-	4.13	-	6.63 6.93
Critical Hdwy Stg 1	-	-	-	-	5.83 -
Critical Hdwy Stg 2	-	-	-	-	5.43 -
Follow-up Hdwy	-	-	2.219	-	3.519 3.319
Pot Cap-1 Maneuver	-	-	494	-	~ 16 388
Stage 1	-	-	-	-	201 -
Stage 2	-	-	-	-	210 -
Platoon blocked, %	-	-	-	-	-
Mov Cap-1 Maneuver	-	-	494	-	~ 12 388
Mov Cap-2 Maneuver	-	-	-	-	~ 12 -
Stage 1	-	-	-	-	201 -
Stage 2	-	-	-	-	161 -



















Approach	EB	WB	NB
HCM Control Delay, s	0	1.2	117.4
HCM LOS			F

Minor Lane/Major Mvmt	NBLn1	NBLn2	EBT	EBR	WBL	WBT
Capacity (veh/h)	12	388	-	-	494	-
HCM Lane V/C Ratio	1.685	0.46	-	-	0.231	-
HCM Control Delay (s)	\$ 960.5	22	-	-	14.5	-
HCM Lane LOS	F	C	-	-	B	-
HCM 95th %tile Q(veh)	3.3	2.3	-	-	0.9	-

Notes  
 ~: Volume exceeds capacity    \$: Delay exceeds 300s    +: Computation Not Defined    \*: All major volume in platoon

HCM Signalized Intersection Capacity Analysis General Plan 2040 Project Altern. A Conditions  
6: Conde Lane & Shiloh Road

Timing Plan: P.M. Peak

													
Movement	EBL	EBT	EBR	WBL	WBT	WBR	NBL	NBT	NBR	SBL	SBT	SBR	
Lane Configurations													
Traffic Volume (vph)	77	737	0	9	747	372	4	2	16	387	4	65	
Future Volume (vph)	77	737	0	9	747	372	4	2	16	387	4	65	
Ideal Flow (vphp)	1900	1900	1900	1900	1900	1900	1900	1900	1900	1900	1900	1900	
Total Lost time (s)	4.0	4.0		4.0	4.0			4.0			4.0	4.0	
Lane Util. Factor	1.00	0.95		1.00	0.95			1.00			1.00	1.00	
Frbp, ped/bikes	1.00	1.00		1.00	0.99			1.00			1.00	1.00	
Flpb, ped/bikes	1.00	1.00		1.00	1.00			1.00			1.00	1.00	
Frt	1.00	1.00		1.00	0.95			0.90			1.00	0.85	
Flt Protected	0.95	1.00		0.95	1.00			0.99			0.95	1.00	
Satd. Flow (prot)	1770	3539		1770	3339			1663			1775	1583	
Flt Permitted	0.95	1.00		0.95	1.00			0.99			0.95	1.00	
Satd. Flow (perm)	1770	3539		1770	3339			1663			1775	1583	
Peak-hour factor, PHF	0.88	0.88	0.88	0.80	0.80	0.80	0.63	0.63	0.63	0.88	0.88	0.88	
Adj. Flow (vph)	88	838	0	11	934	465	6	3	25	440	5	74	
RTOR Reduction (vph)	0	0	0	0	42	0	0	23	0	0	0	0	
Lane Group Flow (vph)	88	838	0	11	1357	0	0	11	0	0	445	74	
Confl. Peds. (#/hr)	1						1						
Turn Type	Prot	NA		Prot	NA		Split	NA		Split	NA	custom	
Protected Phases	5	2		1	6		7	7		4	4		
Permitted Phases												6	
Actuated Green, G (s)	6.6	49.4		1.4	44.2			5.4			11.2	44.2	
Effective Green, g (s)	6.6	49.4		1.4	44.2			5.4			11.2	44.2	
Actuated g/C Ratio	0.08	0.59		0.02	0.53			0.06			0.13	0.53	
Clearance Time (s)	4.0	4.0		4.0	4.0			4.0			4.0	4.0	
Vehicle Extension (s)	3.0	3.0		3.0	3.0			3.0			3.0	3.0	
Lane Grp Cap (vph)	140	2096		29	1769			107			238	838	
v/s Ratio Prot	c0.05	0.24		0.01	c0.41			c0.01			c0.25		
v/s Ratio Perm												0.05	
v/c Ratio	0.63	0.40		0.38	0.77			0.10			1.87	0.09	
Uniform Delay, d1	37.2	9.1		40.6	15.5			36.7			36.1	9.7	
Progression Factor	1.00	1.00		1.00	1.00			1.00			1.00	1.00	
Incremental Delay, d2	8.5	0.1		8.1	2.0			0.4			407.0	0.0	
Delay (s)	45.7	9.2		48.7	17.6			37.1			443.1	9.7	
Level of Service	D	A		D	B			D			F	A	
Approach Delay (s)		12.7			17.8			37.1			381.3		
Approach LOS		B			B			D			F		
<b>Intersection Summary</b>													
HCM 2000 Control Delay			81.7									HCM 2000 Level of Service	F
HCM 2000 Volume to Capacity ratio			0.88										
Actuated Cycle Length (s)			83.4									Sum of lost time (s)	16.0
Intersection Capacity Utilization			77.6%									ICU Level of Service	D
Analysis Period (min)			15										
c Critical Lane Group													

HCM 6th TWSC  
7: Driveway 1/Gridley Drive & Shiloh Road

General Plan 2040 Project Altern. A Conditions  
Timing Plan: P.M. Peak

Intersection												
Int Delay, s/veh	4.7											
Movement	EBL	EBT	EBR	WBL	WBT	WBR	NBL	NBT	NBR	SBL	SBT	SBR
Lane Configurations		↔	↔		↔		↔	↔			↔	
Traffic Vol, veh/h	25	521	121	0	443	0	84	0	0	0	0	21
Future Vol, veh/h	25	521	121	0	443	0	84	0	0	0	0	21
Conflicting Peds, #/hr	1	0	0	0	0	0	0	0	0	0	0	0
Sign Control	Free	Free	Free	Free	Free	Free	Stop	Stop	Stop	Stop	Stop	Stop
RT Channelized	-	-	None	-	-	None	-	-	None	-	-	None
Storage Length	-	-	150	-	-	-	0	-	-	-	-	-
Veh in Median Storage, #	-	0	-	-	0	-	-	0	-	-	0	-
Grade, %	-	0	-	-	0	-	-	0	-	-	0	-
Peak Hour Factor	94	94	94	69	69	69	100	100	100	58	58	58
Heavy Vehicles, %	2	2	2	2	2	2	2	2	2	2	2	2
Mvmt Flow	27	554	129	0	642	0	84	0	0	0	0	36

Major/Minor	Major1			Major2			Minor1			Minor2		
Conflicting Flow All	643	0	0	683	0	0	1268	1251	554	1316	1380	643
Stage 1	-	-	-	-	-	-	608	608	-	643	643	-
Stage 2	-	-	-	-	-	-	660	643	-	673	737	-
Critical Hdwy	4.12	-	-	4.12	-	-	7.12	6.52	6.22	7.12	6.52	6.22
Critical Hdwy Stg 1	-	-	-	-	-	-	6.12	5.52	-	6.12	5.52	-
Critical Hdwy Stg 2	-	-	-	-	-	-	6.12	5.52	-	6.12	5.52	-
Follow-up Hdwy	2.218	-	-	2.218	-	-	3.518	4.018	3.318	3.518	4.018	3.318
Pot Cap-1 Maneuver	942	-	-	910	-	-	145	172	532	135	144	473
Stage 1	-	-	-	-	-	-	483	486	-	462	468	-
Stage 2	-	-	-	-	-	-	452	468	-	445	425	-
Platoon blocked, %		-	-		-	-						
Mov Cap-1 Maneuver	941	-	-	910	-	-	129	164	532	130	137	473
Mov Cap-2 Maneuver	-	-	-	-	-	-	129	164	-	130	137	-
Stage 1	-	-	-	-	-	-	460	463	-	440	468	-
Stage 2	-	-	-	-	-	-	417	468	-	424	405	-

Approach	EB	WB	NB	SB
HCM Control Delay, s	0.3	0	74.2	13.2
HCM LOS			F	B

Minor Lane/Major Mvmt	NBLn1	NBLn2	EBL	EBT	EBR	WBL	WBT	WBR	SBLn1
Capacity (veh/h)	129	-	941	-	-	910	-	-	473
HCM Lane V/C Ratio	0.651	-	0.028	-	-	-	-	-	0.077
HCM Control Delay (s)	74.2	0	8.9	0	-	0	-	-	13.2
HCM Lane LOS	F	A	A	A	-	A	-	-	B
HCM 95th %tile Q(veh)	3.5	-	0.1	-	-	0	-	-	0.2



HCM 6th TWSC  
8: Old Redwood Hwy & Driveway 2

General Plan 2040 Project Altern. A Conditions  
Timing Plan: P.M. Peak

Intersection												
Int Delay, s/veh	50.8											
Movement	EBL	EBT	EBR	WBL	WBT	WBR	NBL	NBT	NBR	SBL	SBT	SBR
Lane Configurations		↕		↕	↕			↕	↕	↕	↕	
Traffic Vol, veh/h	4	0	0	49	0	79	0	1195	71	114	1152	0
Future Vol, veh/h	4	0	0	49	0	79	0	1195	71	114	1152	0
Conflicting Peds, #/hr	0	0	0	0	0	0	0	0	0	0	0	0
Sign Control	Stop	Stop	Stop	Stop	Stop	Stop	Free	Free	Free	Free	Free	Free
RT Channelized	-	-	None	-	-	None	-	-	None	-	-	None
Storage Length	-	-	-	0	-	-	-	-	100	50	-	-
Veh in Median Storage, #	-	0	-	-	0	-	-	0	-	-	0	-
Grade, %	-	0	-	-	0	-	-	0	-	-	0	-
Peak Hour Factor	38	38	38	100	100	100	91	91	91	94	94	94
Heavy Vehicles, %	2	2	2	2	2	2	2	2	2	2	2	2
Mvmt Flow	11	0	0	49	0	79	0	1313	78	121	1226	0

Major/Minor	Minor2		Minor1		Major1		Major2					
Conflicting Flow All	2860	2859	1226	2781	2781	1313	1226	0	0	1391	0	0
Stage 1	1468	1468	-	1313	1313	-	-	-	-	-	-	-
Stage 2	1392	1391	-	1468	1468	-	-	-	-	-	-	-
Critical Hdwy	7.12	6.52	6.22	7.12	6.52	6.22	4.12	-	-	4.12	-	-
Critical Hdwy Stg 1	6.12	5.52	-	6.12	5.52	-	-	-	-	-	-	-
Critical Hdwy Stg 2	6.12	5.52	-	6.12	5.52	-	-	-	-	-	-	-
Follow-up Hdwy	3.518	4.018	3.318	3.518	4.018	3.318	2.218	-	-	2.218	-	-
Pot Cap-1 Maneuver	11	17	218	~ 12	19	194	569	-	-	492	-	-
Stage 1	159	192	-	195	228	-	-	-	-	-	-	-
Stage 2	176	209	-	159	192	-	-	-	-	-	-	-
Platoon blocked, %								-	-	-	-	-
Mov Cap-1 Maneuver	~ 5	13	218	~ 10	14	194	569	-	-	492	-	-
Mov Cap-2 Maneuver	~ 5	13	-	~ 10	14	-	-	-	-	-	-	-
Stage 1	159	145	-	195	228	-	-	-	-	-	-	-
Stage 2	104	209	-	120	145	-	-	-	-	-	-	-

Approach	EB		WB		NB		SB	
HCM Control Delay, \$	1836.2		\$ 976.4		0		1.3	
HCM LOS	F		F					

Minor Lane/Major Mvmt	NBL	NBT	NBR	EBLn1	WBLn1	WBLn2	SBL	SBT	SBR
Capacity (veh/h)	569	-	-	5	10	194	492	-	-
HCM Lane V/C Ratio	-	-	-	2.105	4.9	0.407	0.246	-	-
HCM Control Delay (s)	0	-	-	\$ 1836.2	\$ 2493	35.7	14.7	-	-
HCM Lane LOS	A	-	-	F	F	E	B	-	-
HCM 95th %tile Q(veh)	0	-	-	2.4	7.4	1.8	1	-	-

Notes  
 ~: Volume exceeds capacity    \$: Delay exceeds 300s    +: Computation Not Defined    \*: All major volume in platoon

Intersection						
Int Delay, s/veh	4.9					
Movement	EBT	EBR	WBL	WBT	NBL	NBR
Lane Configurations	↑	↗		↖	↖	↗
Traffic Vol, veh/h	120	369	35	164	258	25
Future Vol, veh/h	120	369	35	164	258	25
Conflicting Peds, #/hr	0	0	0	0	0	0
Sign Control	Free	Free	Free	Free	Stop	Stop
RT Channelized	-	None	-	None	-	None
Storage Length	-	200	-	-	0	0
Veh in Median Storage, #	0	-	-	0	0	-
Grade, %	0	-	-	0	0	-
Peak Hour Factor	92	92	68	68	100	100
Heavy Vehicles, %	2	2	2	2	2	2
Mvmt Flow	130	401	51	241	258	25

Major/Minor	Major1	Major2	Minor1		
Conflicting Flow All	0	0	531	0	473
Stage 1	-	-	-	-	130
Stage 2	-	-	-	-	343
Critical Hdwy	-	-	4.12	-	6.42
Critical Hdwy Stg 1	-	-	-	-	5.42
Critical Hdwy Stg 2	-	-	-	-	5.42
Follow-up Hdwy	-	-	2.218	-	3.518
Pot Cap-1 Maneuver	-	-	1036	-	550
Stage 1	-	-	-	-	896
Stage 2	-	-	-	-	719
Platoon blocked, %	-	-	-	-	-
Mov Cap-1 Maneuver	-	-	1036	-	519
Mov Cap-2 Maneuver	-	-	-	-	519
Stage 1	-	-	-	-	896
Stage 2	-	-	-	-	678

Approach	EB	WB	NB
HCM Control Delay, s	0	1.5	17.8
HCM LOS			C

Minor Lane/Major Mvmt	NBLn1	NBLn2	EBT	EBR	WBL	WBT
Capacity (veh/h)	519	920	-	-	1036	-
HCM Lane V/C Ratio	0.497	0.027	-	-	0.05	-
HCM Control Delay (s)	18.6	9	-	-	8.7	0
HCM Lane LOS	C	A	-	-	A	A
HCM 95th %tile Q(veh)	2.7	0.1	-	-	0.2	-

HCM 6th Signalized Intersection Summary      General Plan 2040 Project Altern. A Conditions  
 10: US 101 NB Off Ramp/Lakewood Drive & Old Redwood Highway      Timing Plan: P.M. Peak

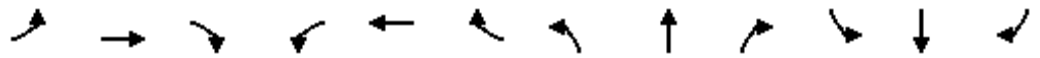

Movement	EBL	EBT	EBR	WBL	WBT	WBR	NBL	NBT	NBR	SBL	SBT	SBR
Lane Configurations	↔↔	↑			↑↑		↔	↔↔		↔↔		↔
Traffic Volume (veh/h)	309	743	0	0	764	270	528	539	303	386	0	618
Future Volume (veh/h)	309	743	0	0	764	270	528	539	303	386	0	618
Initial Q (Qb), veh	0	0	0	0	0	0	0	0	0	0	0	0
Ped-Bike Adj(A_pbT)	1.00		1.00	1.00		0.98	1.00		0.99	1.00		1.00
Parking Bus, Adj	1.00	1.00	1.00	1.00	1.00	1.00	1.00	1.00	1.00	1.00	1.00	1.00
Work Zone On Approach		No			No			No			No	
Adj Sat Flow, veh/h/ln	1870	1870	0	0	1870	1870	1870	1870	1870	1870	0	1870
Adj Flow Rate, veh/h	355	854	0	0	840	297	496	695	329	402	0	0
Peak Hour Factor	0.87	0.87	0.87	0.91	0.91	0.91	0.92	0.92	0.92	0.96	0.96	0.96
Percent Heavy Veh, %	2	2	0	0	2	2	2	2	2	2	0	2
Cap, veh/h	404	978	0	0	905	319	623	838	396	0	0	0
Arrive On Green	0.12	0.52	0.00	0.00	0.35	0.35	0.35	0.35	0.35	0.00	0.00	0.00
Sat Flow, veh/h	3456	1870	0	0	2653	903	1781	2394	1133		0	
Grp Volume(v), veh/h	355	854	0	0	583	554	496	543	481		0.0	
Grp Sat Flow(s),veh/h/ln	1728	1870	0	0	1777	1686	1781	1870	1657			
Q Serve(g_s), s	7.8	30.8	0.0	0.0	24.2	24.3	19.3	20.4	20.5			
Cycle Q Clear(g_c), s	7.8	30.8	0.0	0.0	24.2	24.3	19.3	20.4	20.5			
Prop In Lane	1.00		0.00	0.00		0.54	1.00		0.68			
Lane Grp Cap(c), veh/h	404	978	0	0	628	596	623	654	580			
V/C Ratio(X)	0.88	0.87	0.00	0.00	0.93	0.93	0.80	0.83	0.83			
Avail Cap(c_a), veh/h	404	978	0	0	628	596	672	705	625			
HCM Platoon Ratio	1.00	1.00	1.00	1.00	1.00	1.00	1.00	1.00	1.00			
Upstream Filter(I)	1.00	1.00	0.00	0.00	1.00	1.00	1.00	1.00	1.00			
Uniform Delay (d), s/veh	33.4	16.1	0.0	0.0	23.9	23.9	22.5	22.9	22.9			
Incr Delay (d2), s/veh	19.2	10.7	0.0	0.0	21.9	23.1	6.2	7.8	8.7			
Initial Q Delay(d3),s/veh	0.0	0.0	0.0	0.0	0.0	0.0	0.0	0.0	0.0			
%ile BackOfQ(50%),veh/ln	4.2	14.1	0.0	0.0	13.1	12.7	8.6	9.8	8.9			
Unsig. Movement Delay, s/veh												
LnGrp Delay(d),s/veh	52.6	26.8	0.0	0.0	45.8	47.0	28.8	30.7	31.6			
LnGrp LOS	D	C	A	A	D	D	C	C	C			
Approach Vol, veh/h		1209			1137			1520				
Approach Delay, s/veh		34.4			46.4			30.3				
Approach LOS		C			D			C				
Timer - Assigned Phs		2			5	6		8				
Phs Duration (G+Y+Rc), s		45.3			13.0	32.3		31.6				
Change Period (Y+Rc), s		5.1			4.0	5.1		4.7				
Max Green Setting (Gmax), s		40.2			9.0	27.2		29.0				
Max Q Clear Time (g_c+I1), s		32.8			9.8	26.3		22.5				
Green Ext Time (p_c), s		3.5			0.0	0.6		4.3				

**Intersection Summary**

HCM 6th Ctrl Delay	36.3
HCM 6th LOS	D

**Notes**

User approved volume balancing among the lanes for turning movement.  
 Unsignalized Delay for [SBR] is excluded from calculations of the approach delay and intersection delay.

HCM 6th Signalized Intersection Summary      General Plan 2040 Project Altern. A Conditions  
 12: US 101 SB On Ramp/US 101 SB Off Ramp & Old Redwood Highway      Timing Plan: P.M. Peak



Movement	EBL	EBT	EBR	WBL	WBT	WBR	NBL	NBT	NBR	SBL	SBT	SBR
Lane Configurations		↑↑	↗	↘	↑↑					↘	↕	
Traffic Volume (veh/h)	0	612	501	443	1121	0	0	0	0	372	2	221
Future Volume (veh/h)	0	612	501	443	1121	0	0	0	0	372	2	221
Initial Q (Qb), veh	0	0	0	0	0	0				0	0	0
Ped-Bike Adj(A_pbT)	1.00		0.98	1.00		1.00				1.00		1.00
Parking Bus, Adj	1.00	1.00	1.00	1.00	1.00	1.00				1.00	1.00	1.00
Work Zone On Approach		No			No						No	
Adj Sat Flow, veh/h/ln	0	1870	1870	1870	1870	0				1870	1870	1870
Adj Flow Rate, veh/h	0	651	533	498	1260	0				358	128	0
Peak Hour Factor	0.94	0.94	0.94	0.89	0.89	0.89				0.83	0.83	0.83
Percent Heavy Veh, %	0	2	2	2	2	0				2	2	2
Cap, veh/h	0	1416	622	458	2533	0				262	275	
Arrive On Green	0.00	0.40	0.40	0.26	0.71	0.00				0.15	0.15	0.00
Sat Flow, veh/h	0	3647	1560	1781	3647	0				1781	1870	0
Grp Volume(v), veh/h	0	651	533	498	1260	0				358	128	0
Grp Sat Flow(s),veh/h/ln	0	1777	1560	1781	1777	0				1781	1870	0
Q Serve(g_s), s	0.0	9.4	21.8	18.0	11.0	0.0				10.3	4.4	0.0
Cycle Q Clear(g_c), s	0.0	9.4	21.8	18.0	11.0	0.0				10.3	4.4	0.0
Prop In Lane	0.00		1.00	1.00		0.00				1.00		0.00
Lane Grp Cap(c), veh/h	0	1416	622	458	2533	0				262	275	
V/C Ratio(X)	0.00	0.46	0.86	1.09	0.50	0.00				1.37	0.47	
Avail Cap(c_a), veh/h	0	1416	622	458	2533	0				262	275	
HCM Platoon Ratio	1.00	1.00	1.00	1.00	1.00	1.00				1.00	1.00	1.00
Upstream Filter(I)	0.00	1.00	1.00	1.00	1.00	0.00				1.00	1.00	0.00
Uniform Delay (d), s/veh	0.0	15.5	19.2	26.0	4.5	0.0				29.8	27.3	0.0
Incr Delay (d2), s/veh	0.0	1.1	14.2	67.7	0.7	0.0				187.2	1.2	0.0
Initial Q Delay(d3),s/veh	0.0	0.0	0.0	0.0	0.0	0.0				0.0	0.0	0.0
%ile BackOfQ(50%),veh/ln	0.0	3.6	9.4	15.6	2.6	0.0				17.8	2.0	0.0
Unsig. Movement Delay, s/veh												
LnGrp Delay(d),s/veh	0.0	16.6	33.5	93.7	5.2	0.0				217.0	28.6	0.0
LnGrp LOS	A	B	C	F	A	A				F	C	
Approach Vol, veh/h		1184			1758						486	
Approach Delay, s/veh		24.2			30.2						167.4	
Approach LOS		C			C						F	
Timer - Assigned Phs		2			5	6		8				
Phs Duration (G+Y+Rc), s		55.0			22.0	33.0		15.0				
Change Period (Y+Rc), s		5.1			4.0	5.1		4.7				
Max Green Setting (Gmax), s		49.9			18.0	27.9		10.3				
Max Q Clear Time (g_c+I1), s		13.0			20.0	23.8		12.3				
Green Ext Time (p_c), s		11.9			0.0	2.3		0.0				

**Intersection Summary**























HCM 6th Ctrl Delay	47.6
HCM 6th LOS	D

**Notes**

- User approved volume balancing among the lanes for turning movement.
- User approved ignoring U-Turning movement.
- Unsignalized Delay for [SBR] is excluded from calculations of the approach delay and intersection delay.





















HCM 6th Signalized Intersection Summary  
1: Old Redwood Hwy & Shiloh Road

General Plan 2040 Project Altern. A Conditions  
Timing Plan: Saturday Midday Peak

												
Movement	EBL	EBT	EBR	WBL	WBT	WBR	NBL	NBT	NBR	SBL	SBT	SBR
Lane Configurations												
Traffic Volume (veh/h)	182	506	308	31	522	76	317	352	35	83	285	266
Future Volume (veh/h)	182	506	308	31	522	76	317	352	35	83	285	266
Initial Q (Qb), veh	0	0	0	0	0	0	0	0	0	0	0	0
Ped-Bike Adj(A_pbT)	1.00		0.97	1.00		1.00	1.00		0.98	1.00		0.97
Parking Bus, Adj	1.00	1.00	1.00	1.00	1.00	1.00	1.00	1.00	1.00	1.00	1.00	1.00
Work Zone On Approach		No			No			No			No	
Adj Sat Flow, veh/h/ln	1870	1870	1870	1870	1870	1870	1870	1870	1870	1870	1870	1870
Adj Flow Rate, veh/h	204	569	346	36	607	88	341	378	38	91	313	292
Peak Hour Factor	0.89	0.89	0.89	0.86	0.86	0.86	0.93	0.93	0.93	0.91	0.91	0.91
Percent Heavy Veh, %	2	2	2	2	2	2	2	2	2	2	2	2
Cap, veh/h	426	448	368	31	525	473	196	527	437	77	402	331
Arrive On Green	0.24	0.24	0.24	0.30	0.30	0.30	0.11	0.28	0.28	0.04	0.22	0.22
Sat Flow, veh/h	1781	1870	1538	104	1761	1585	1781	1870	1551	1781	1870	1540
Grp Volume(v), veh/h	204	569	346	643	0	88	341	378	38	91	313	292
Grp Sat Flow(s),veh/h/ln	1781	1870	1538	1865	0	1585	1781	1870	1551	1781	1870	1540
Q Serve(g_s), s	12.5	30.5	28.1	38.0	0.0	5.3	14.0	23.2	2.3	5.5	20.1	23.4
Cycle Q Clear(g_c), s	12.5	30.5	28.1	38.0	0.0	5.3	14.0	23.2	2.3	5.5	20.1	23.4
Prop In Lane	1.00		1.00	0.06		1.00	1.00		1.00	1.00		1.00
Lane Grp Cap(c), veh/h	426	448	368	556	0	473	196	527	437	77	402	331
V/C Ratio(X)	0.48	1.27	0.94	1.16	0.00	0.19	1.74	0.72	0.09	1.18	0.78	0.88
Avail Cap(c_a), veh/h	426	448	368	556	0	473	196	639	530	77	514	423
HCM Platoon Ratio	1.00	1.00	1.00	1.00	1.00	1.00	1.00	1.00	1.00	1.00	1.00	1.00
Upstream Filter(I)	1.00	1.00	1.00	1.00	0.00	1.00	1.00	1.00	1.00	1.00	1.00	1.00
Uniform Delay (d), s/veh	41.6	48.5	47.6	44.7	0.0	33.2	56.7	41.2	33.7	61.0	47.1	48.4
Incr Delay (d2), s/veh	0.8	138.5	31.8	89.0	0.0	0.2	354.3	3.0	0.1	160.3	5.7	16.0
Initial Q Delay(d3),s/veh	0.0	0.0	0.0	0.0	0.0	0.0	0.0	0.0	0.0	0.0	0.0	0.0
%ile BackOfQ(50%),veh/ln	5.5	31.1	13.7	30.8	0.0	2.0	25.4	10.8	0.9	5.9	9.8	10.3
Unsig. Movement Delay, s/veh												
LnGrp Delay(d),s/veh	42.5	186.9	79.3	133.7	0.0	33.4	411.0	44.2	33.8	221.3	52.9	64.4
LnGrp LOS	D	F	E	F	A	C	F	D	C	F	D	E
Approach Vol, veh/h		1119			731			757			696	
Approach Delay, s/veh		127.3			121.7			208.9			79.7	
Approach LOS		F			F			F			E	
Timer - Assigned Phs		2	3	4		6	7	8				
Phs Duration (G+Y+Rc), s		35.0	18.0	31.9		42.5	9.5	40.4				
Change Period (Y+Rc), s		4.5	4.0	4.5		4.5	4.0	4.5				
Max Green Setting (Gmax), s		30.5	14.0	35.0		38.0	5.5	43.5				
Max Q Clear Time (g_c+I1), s		32.5	16.0	25.4		40.0	7.5	25.2				
Green Ext Time (p_c), s		0.0	0.0	2.0		0.0	0.0	2.0				
<b>Intersection Summary</b>												
HCM 6th Ctrl Delay				134.7								
HCM 6th LOS				F								

HCM 6th Signalized Intersection Summary  
2: Shiloh Road & Hembree Ln

General Plan 2040 Project Altern. A Conditions  
Timing Plan: Saturday Midday Peak

												
Movement	EBL	EBT	EBR	WBL	WBT	WBR	NBL	NBT	NBR	SBL	SBT	SBR
Lane Configurations												
Traffic Volume (veh/h)	918	865	69	110	811	235	111	21	128	236	11	856
Future Volume (veh/h)	918	865	69	110	811	235	111	21	128	236	11	856
Initial Q (Qb), veh	0	0	0	0	0	0	0	0	0	0	0	0
Ped-Bike Adj(A_pbT)	1.00		1.00	1.00		1.00	1.00		1.00	1.00		1.00
Parking Bus, Adj	1.00	1.00	1.00	1.00	1.00	1.00	1.00	1.00	1.00	1.00	1.00	1.00
Work Zone On Approach		No			No			No			No	
Adj Sat Flow, veh/h/ln	1870	1870	1870	1870	1870	1870	1870	1870	1870	1870	1870	1870
Adj Flow Rate, veh/h	977	920	69	110	845	245	111	21	128	259	11	941
Peak Hour Factor	0.94	0.94	1.00	1.00	0.96	0.96	1.00	1.00	1.00	0.91	1.00	0.91
Percent Heavy Veh, %	2	2	2	2	2	2	2	2	2	2	2	2
Cap, veh/h	682	980	73	114	1186	344	114	15	89	199	8	497
Arrive On Green	0.20	0.57	0.57	0.06	0.44	0.44	0.06	0.06	0.06	0.12	0.12	0.12
Sat Flow, veh/h	3456	1718	129	1781	2717	787	1781	228	1392	1712	73	1585
Grp Volume(v), veh/h	977	0	989	110	552	538	111	0	149	270	0	941
Grp Sat Flow(s),veh/h/ln	1728	0	1847	1781	1777	1728	1781	0	1620	1785	0	1585
Q Serve(g_s), s	17.0	0.0	42.6	5.3	21.9	21.9	5.4	0.0	5.5	10.0	0.0	10.0
Cycle Q Clear(g_c), s	17.0	0.0	42.6	5.3	21.9	21.9	5.4	0.0	5.5	10.0	0.0	10.0
Prop In Lane	1.00		0.07	1.00		0.46	1.00		0.86	0.96		1.00
Lane Grp Cap(c), veh/h	682	0	1053	114	776	754	114	0	103	207	0	497
V/C Ratio(X)	1.43	0.00	0.94	0.97	0.71	0.71	0.98	0.00	1.44	1.30	0.00	1.89
Avail Cap(c_a), veh/h	682	0	1137	114	857	833	114	0	103	207	0	497
HCM Platoon Ratio	1.00	1.00	1.00	1.00	1.00	1.00	1.00	1.00	1.00	1.00	1.00	1.00
Upstream Filter(I)	1.00	0.00	1.00	1.00	1.00	1.00	1.00	0.00	1.00	1.00	0.00	1.00
Uniform Delay (d), s/veh	34.5	0.0	17.1	40.2	19.8	19.8	40.2	0.0	40.3	38.0	0.0	29.5
Incr Delay (d2), s/veh	202.6	0.0	13.9	73.6	2.5	2.6	76.3	0.0	244.0	166.6	0.0	409.3
Initial Q Delay(d3),s/veh	0.0	0.0	0.0	0.0	0.0	0.0	0.0	0.0	0.0	0.0	0.0	0.0
%ile BackOfQ(50%),veh/ln	25.9	0.0	18.8	4.6	8.7	8.4	4.7	0.0	9.2	13.8	0.0	66.3
Unsig. Movement Delay, s/veh												
LnGrp Delay(d),s/veh	237.2	0.0	31.0	113.8	22.3	22.4	116.5	0.0	284.3	204.6	0.0	438.8
LnGrp LOS	F	A	C	F	C	C	F	A	F	F	A	F
Approach Vol, veh/h		1966			1200			260			1211	
Approach Delay, s/veh		133.5			30.7			212.7			386.6	
Approach LOS		F			C			F			F	
Timer - Assigned Phs	1	2		4	5	6		8				
Phs Duration (G+Y+Rc), s	9.5	53.1		14.0	21.0	41.6		9.5				
Change Period (Y+Rc), s	4.0	4.0		4.0	4.0	4.0		4.0				
Max Green Setting (Gmax), s	5.5	53.0		10.0	17.0	41.5		5.5				
Max Q Clear Time (g_c+I1), s	7.3	44.6		12.0	19.0	23.9		7.5				
Green Ext Time (p_c), s	0.0	4.4		0.0	0.0	6.6		0.0				
<b>Intersection Summary</b>												
HCM 6th Ctrl Delay					177.4							
HCM 6th LOS					F							

HCM 6th Signalized Intersection Summary  
 3: US 101 NB Off-Ramp & Shiloh Road

General Plan 2040 Project Altern. A Conditions  
 Timing Plan: Saturday Midday Peak



Movement	EBT	EBR	WBL	WBT	NBL	NBR
Lane Configurations	↑↑			↑	↘	↗
Traffic Volume (veh/h)	720	0	0	1243	520	1061
Future Volume (veh/h)	720	0	0	1243	520	1061
Initial Q (Qb), veh	0	0	0	0	0	0
Ped-Bike Adj(A_pbT)		1.00	1.00		1.00	1.00
Parking Bus, Adj	1.00	1.00	1.00	1.00	1.00	1.00
Work Zone On Approach	No			No	No	
Adj Sat Flow, veh/h/ln	1870	0	0	1870	1870	1870
Adj Flow Rate, veh/h	791	0	0	1397	547	1117
Peak Hour Factor	0.91	0.91	0.89	0.89	0.95	0.95
Percent Heavy Veh, %	2	0	0	2	2	2
Cap, veh/h	1609	0	0	847	752	1177
Arrive On Green	0.45	0.00	0.00	0.45	0.42	0.42
Sat Flow, veh/h	3741	0	0	1870	1781	2790
Grp Volume(v), veh/h	791	0	0	1397	547	1117
Grp Sat Flow(s),veh/h/ln	1777	0	0	1870	1781	1395
Q Serve(g_s), s	11.3	0.0	0.0	32.5	18.4	27.7
Cycle Q Clear(g_c), s	11.3	0.0	0.0	32.5	18.4	27.7
Prop In Lane		0.00	0.00		1.00	1.00
Lane Grp Cap(c), veh/h	1609	0	0	847	752	1177
V/C Ratio(X)	0.49	0.00	0.00	1.65	0.73	0.95
Avail Cap(c_a), veh/h	1609	0	0	847	757	1185
HCM Platoon Ratio	1.00	1.00	1.00	1.00	1.00	1.00
Upstream Filter(I)	1.00	0.00	0.00	1.00	1.00	1.00
Uniform Delay (d), s/veh	13.8	0.0	0.0	19.6	17.3	20.0
Incr Delay (d2), s/veh	0.2	0.0	0.0	297.8	3.5	15.4
Initial Q Delay(d3),s/veh	0.0	0.0	0.0	0.0	0.0	0.0
%ile BackOfQ(50%),veh/ln	3.9	0.0	0.0	81.8	7.5	10.6
Unsig. Movement Delay, s/veh						
LnGrp Delay(d),s/veh	14.1	0.0	0.0	317.5	20.8	35.5
LnGrp LOS	B	A	A	F	C	D
Approach Vol, veh/h	791			1397	1664	
Approach Delay, s/veh	14.1			317.5	30.6	
Approach LOS	B			F	C	
Timer - Assigned Phs		2			6	8
Phs Duration (G+Y+Rc), s		37.0			37.0	34.8
Change Period (Y+Rc), s		4.5			4.5	4.5
Max Green Setting (Gmax), s		32.5			32.5	30.5
Max Q Clear Time (g_c+I1), s		13.3			34.5	29.7
Green Ext Time (p_c), s		5.0			0.0	0.6
<b>Intersection Summary</b>						
HCM 6th Ctrl Delay			131.3			
HCM 6th LOS			F			

# HCM Signalized Intersection Capacity Analysis General Plan 2040 Project Altern. A Conditions 4: Shiloh Road & US 101 SB Off-Ramp

Timing Plan: Saturday Midday Peak



Movement	EBL	EBT	WBT	WBR	SBL	SBR
Lane Configurations		↑	↑		↓	↓
Traffic Volume (vph)	0	424	794	0	412	223
Future Volume (vph)	0	424	794	0	412	223
Ideal Flow (vphpl)	1900	1900	1900	1900	1900	1900
Total Lost time (s)		4.5	4.5		4.5	4.5
Lane Util. Factor		1.00	1.00		1.00	1.00
Frbp, ped/bikes		1.00	1.00		1.00	1.00
Flpb, ped/bikes		1.00	1.00		1.00	1.00
Frt		1.00	1.00		1.00	0.85
Flt Protected		1.00	1.00		0.95	1.00
Satd. Flow (prot)		1863	1863		1770	1583
Flt Permitted		1.00	1.00		0.95	1.00
Satd. Flow (perm)		1863	1863		1770	1583
Peak-hour factor, PHF	0.96	0.96	0.96	0.96	0.68	0.68
Adj. Flow (vph)	0	442	827	0	606	328
RTOR Reduction (vph)	0	0	0	0	0	170
Lane Group Flow (vph)	0	442	827	0	606	158
Confl. Bikes (#/hr)				2		
Turn Type		NA	NA		Perm	Perm
Protected Phases		2	6			
Permitted Phases					4	4
Actuated Green, G (s)		30.8	30.8		16.9	16.9
Effective Green, g (s)		30.8	30.8		16.9	16.9
Actuated g/C Ratio		0.54	0.54		0.30	0.30
Clearance Time (s)		4.5	4.5		4.5	4.5
Vehicle Extension (s)		3.0	3.0		3.0	3.0
Lane Grp Cap (vph)		1012	1012		527	471
v/s Ratio Prot		0.24	c0.44			
v/s Ratio Perm					c0.34	0.10
v/c Ratio		0.44	0.82		1.15	0.34
Uniform Delay, d1		7.8	10.6		19.9	15.5
Progression Factor		1.00	1.00		1.00	1.00
Incremental Delay, d2		0.3	5.2		87.6	0.4
Delay (s)		8.1	15.8		107.5	15.9
Level of Service		A	B		F	B
Approach Delay (s)		8.1	15.8		75.4	
Approach LOS		A	B		E	
<b>Intersection Summary</b>						
HCM 2000 Control Delay			39.5		HCM 2000 Level of Service	D
HCM 2000 Volume to Capacity ratio			0.93			
Actuated Cycle Length (s)			56.7		Sum of lost time (s)	9.0
Intersection Capacity Utilization			156.3%		ICU Level of Service	H
Analysis Period (min)			15			
c Critical Lane Group						



Intersection						
Int Delay, s/veh	5.8					
Movement	EBT	EBR	WBL	WBT	NBL	NBR
Lane Configurations	↑↑		↘	↑	↘	↘
Traffic Vol, veh/h	826	30	120	911	24	115
Future Vol, veh/h	826	30	120	911	24	115
Conflicting Peds, #/hr	0	0	0	0	1	0
Sign Control	Free	Free	Free	Free	Stop	Stop
RT Channelized	-	None	-	None	-	None
Storage Length	-	-	68	-	0	0
Veh in Median Storage, #	0	-	-	0	0	-
Grade, %	0	-	-	0	0	-
Peak Hour Factor	92	92	87	87	78	78
Heavy Vehicles, %	2	2	2	2	2	2
Mvmt Flow	898	33	138	1047	31	147

Major/Minor	Major1	Major2	Minor1	Minor2	Minor3
Conflicting Flow All	0	0	931	0	2239
Stage 1	-	-	-	-	915
Stage 2	-	-	-	-	1324
Critical Hdwy	-	-	4.13	-	6.63
Critical Hdwy Stg 1	-	-	-	-	5.83
Critical Hdwy Stg 2	-	-	-	-	5.43
Follow-up Hdwy	-	-	2.219	-	3.519
Pot Cap-1 Maneuver	-	-	733	-	41
Stage 1	-	-	-	-	352
Stage 2	-	-	-	-	248
Platoon blocked, %	-	-	-	-	-
Mov Cap-1 Maneuver	-	-	733	-	33
Mov Cap-2 Maneuver	-	-	-	-	33
Stage 1	-	-	-	-	352
Stage 2	-	-	-	-	201



















Approach	EB	WB	NB
HCM Control Delay, s	0	1.3	65.8
HCM LOS			F

Minor Lane/Major Mvmt	NBLn1	NBLn2	EBT	EBR	WBL	WBT
Capacity (veh/h)	33	544	-	-	733	-
HCM Lane V/C Ratio	0.932	0.271	-	-	0.188	-
HCM Control Delay (s)	\$ 313.4	14.1	-	-	11	-
HCM Lane LOS	F	B	-	-	B	-
HCM 95th %tile Q(veh)	3.3	1.1	-	-	0.7	-

# HCM Signalized Intersection Capacity Analysis General Plan 2040 Project Altern. A Conditions

## 6: Conde Lane & Shiloh Road

Timing Plan: Saturday Midday Peak

													
Movement	EBL	EBT	EBR	WBL	WBT	WBR	NBL	NBT	NBR	SBL	SBT	SBR	
Lane Configurations													
Traffic Volume (vph)	43	554	1	13	614	301	1	0	9	291	0	41	
Future Volume (vph)	43	554	1	13	614	301	1	0	9	291	0	41	
Ideal Flow (vphp)	1900	1900	1900	1900	1900	1900	1900	1900	1900	1900	1900	1900	
Total Lost time (s)	4.5	4.5		4.5	4.5			4.5			4.5	4.5	
Lane Util. Factor	1.00	0.95		1.00	0.95			1.00			1.00	1.00	
Frbp, ped/bikes	1.00	1.00		1.00	0.99			1.00			1.00	1.00	
Flpb, ped/bikes	1.00	1.00		1.00	1.00			1.00			1.00	1.00	
Frt	1.00	1.00		1.00	0.95			0.88			1.00	0.85	
Flt Protected	0.95	1.00		0.95	1.00			0.99			0.95	1.00	
Satd. Flow (prot)	1770	3538		1770	3340			1630			1770	1583	
Flt Permitted	0.95	1.00		0.95	1.00			0.99			0.95	1.00	
Satd. Flow (perm)	1770	3538		1770	3340			1630			1770	1583	
Peak-hour factor, PHF	0.96	0.96	0.96	0.91	0.91	0.91	0.58	0.58	0.58	0.78	0.78	0.78	
Adj. Flow (vph)	45	577	1	14	675	331	2	0	16	373	0	53	
RTOR Reduction (vph)	0	0	0	0	49	0	0	17	0	0	0	0	
Lane Group Flow (vph)	45	578	0	14	957	0	0	1	0	0	373	53	
Confl. Bikes (#/hr)						2							
Turn Type	Prot	NA		Prot	NA		Split	NA		Split	NA	custom	
Protected Phases	5	2		1	6		7	7		4	4		
Permitted Phases												6	
Actuated Green, G (s)	4.1	30.7		1.1	27.7			2.8			12.6	27.7	
Effective Green, g (s)	4.1	30.7		1.1	27.7			2.8			12.6	27.7	
Actuated g/C Ratio	0.06	0.47		0.02	0.42			0.04			0.19	0.42	
Clearance Time (s)	4.5	4.5		4.5	4.5			4.5			4.5	4.5	
Vehicle Extension (s)	3.0	3.0		3.0	3.0			3.0			3.0	3.0	
Lane Grp Cap (vph)	111	1665		29	1418			70			342	672	
v/s Ratio Prot	c0.03	c0.16		0.01	c0.29			c0.00			c0.21		
v/s Ratio Perm												0.03	
v/c Ratio	0.41	0.35		0.48	0.67			0.01			1.09	0.08	
Uniform Delay, d1	29.4	10.9		31.8	15.1			29.9			26.3	11.2	
Progression Factor	1.00	1.00		1.00	1.00			1.00			1.00	1.00	
Incremental Delay, d2	2.4	0.1		12.1	1.3			0.1			75.2	0.1	
Delay (s)	31.8	11.0		43.9	16.4			29.9			101.5	11.2	
Level of Service	C	B		D	B			C			F	B	
Approach Delay (s)		12.5			16.8			29.9			90.2		
Approach LOS		B			B			C			F		
<b>Intersection Summary</b>													
HCM 2000 Control Delay			30.6									HCM 2000 Level of Service	C
HCM 2000 Volume to Capacity ratio			0.72										
Actuated Cycle Length (s)			65.2									Sum of lost time (s)	18.0
Intersection Capacity Utilization			66.0%									ICU Level of Service	C
Analysis Period (min)			15										
c Critical Lane Group													

HCM 6th TWSC  
7: Driveway 1/Gridley Drive & Shiloh Road

General Plan 2040 Project Altern. A Conditions  
Timing Plan: Saturday Midday Peak

Intersection												
Int Delay, s/veh	8											
Movement	EBL	EBT	EBR	WBL	WBT	WBR	NBL	NBT	NBR	SBL	SBT	SBR
Lane Configurations		↔	↔		↔		↔	↔			↔	
Traffic Vol, veh/h	30	499	112	0	491	0	116	0	0	0	0	27
Future Vol, veh/h	30	499	112	0	491	0	116	0	0	0	0	27
Conflicting Peds, #/hr	1	0	0	0	0	0	0	0	0	0	0	0
Sign Control	Free	Free	Free	Free	Free	Free	Stop	Stop	Stop	Stop	Stop	Stop
RT Channelized	-	-	None	-	-	None	-	-	None	-	-	None
Storage Length	-	-	150	-	-	-	0	-	-	-	-	-
Veh in Median Storage, #	-	0	-	-	0	-	-	0	-	-	0	-
Grade, %	-	0	-	-	0	-	-	0	-	-	0	-
Peak Hour Factor	93	93	93	88	88	88	100	100	100	56	56	56
Heavy Vehicles, %	2	2	2	2	2	2	2	2	2	2	2	2
Mvmt Flow	32	537	120	0	558	0	116	0	0	0	0	48

Major/Minor	Major1			Major2			Minor1			Minor2		
Conflicting Flow All	559	0	0	657	0	0	1183	1160	537	1220	1280	559
Stage 1	-	-	-	-	-	-	601	601	-	559	559	-
Stage 2	-	-	-	-	-	-	582	559	-	661	721	-
Critical Hdwy	4.12	-	-	4.12	-	-	7.12	6.52	6.22	7.12	6.52	6.22
Critical Hdwy Stg 1	-	-	-	-	-	-	6.12	5.52	-	6.12	5.52	-
Critical Hdwy Stg 2	-	-	-	-	-	-	6.12	5.52	-	6.12	5.52	-
Follow-up Hdwy	2.218	-	-	2.218	-	-	3.518	4.018	3.318	3.518	4.018	3.318
Pot Cap-1 Maneuver	1012	-	-	931	-	-	166	195	544	157	166	529
Stage 1	-	-	-	-	-	-	487	489	-	513	511	-
Stage 2	-	-	-	-	-	-	499	511	-	452	432	-
Platoon blocked, %		-	-		-	-						
Mov Cap-1 Maneuver	1011	-	-	931	-	-	145	185	544	151	157	528
Mov Cap-2 Maneuver	-	-	-	-	-	-	145	185	-	151	157	-
Stage 1	-	-	-	-	-	-	462	464	-	486	510	-
Stage 2	-	-	-	-	-	-	453	510	-	429	410	-

Approach	EB	WB	NB	SB
HCM Control Delay, s	0.4	0	89.5	12.5
HCM LOS			F	B

Minor Lane/Major Mvmt	NBLn1	NBLn2	EBL	EBT	EBR	WBL	WBT	WBR	SBLn1
Capacity (veh/h)	145	-	1011	-	-	931	-	-	528
HCM Lane V/C Ratio	0.8	-	0.032	-	-	-	-	-	0.091
HCM Control Delay (s)	89.5	0	8.7	0	-	0	-	-	12.5
HCM Lane LOS	F	A	A	A	-	A	-	-	B
HCM 95th %tile Q(veh)	5	-	0.1	-	-	0	-	-	0.3

HCM 6th TWSC  
8: Old Redwood Hwy & Driveway 2

General Plan 2040 Project Altern. A Conditions  
Timing Plan: Saturday Midday Peak

Intersection												
Int Delay, s/veh	5.9											
Movement	EBL	EBT	EBR	WBL	WBT	WBR	NBL	NBT	NBR	SBL	SBT	SBR
Lane Configurations		↕		↕	↕			↕	↕	↕	↕	
Traffic Vol, veh/h	1	0	3	68	0	109	1	595	66	105	505	6
Future Vol, veh/h	1	0	3	68	0	109	1	595	66	105	505	6
Conflicting Peds, #/hr	0	0	0	0	0	0	1	0	4	4	0	1
Sign Control	Stop	Stop	Stop	Stop	Stop	Stop	Free	Free	Free	Free	Free	Free
RT Channelized	-	-	None	-	-	None	-	-	None	-	-	None
Storage Length	-	-	-	0	-	-	-	-	100	50	-	-
Veh in Median Storage, #	-	0	-	-	0	-	-	0	-	-	0	-
Grade, %	-	0	-	-	0	-	-	0	-	-	0	-
Peak Hour Factor	38	38	38	100	100	100	94	94	94	93	93	93
Heavy Vehicles, %	2	2	2	2	2	2	2	2	2	2	2	2
Mvmt Flow	3	0	8	68	0	109	1	633	70	113	543	6

Major/Minor	Minor2		Minor1		Major1		Major2					
Conflicting Flow All	1498	1482	547	1415	1415	637	550	0	0	707	0	0
Stage 1	773	773	-	639	639	-	-	-	-	-	-	-
Stage 2	725	709	-	776	776	-	-	-	-	-	-	-
Critical Hdwy	7.12	6.52	6.22	7.12	6.52	6.22	4.12	-	-	4.12	-	-
Critical Hdwy Stg 1	6.12	5.52	-	6.12	5.52	-	-	-	-	-	-	-
Critical Hdwy Stg 2	6.12	5.52	-	6.12	5.52	-	-	-	-	-	-	-
Follow-up Hdwy	3.518	4.018	3.318	3.518	4.018	3.318	2.218	-	-	2.218	-	-
Pot Cap-1 Maneuver	101	125	537	115	137	477	1020	-	-	891	-	-
Stage 1	392	409	-	464	470	-	-	-	-	-	-	-
Stage 2	416	437	-	390	407	-	-	-	-	-	-	-
Platoon blocked, %								-	-	-	-	-
Mov Cap-1 Maneuver	70	108	536	102	119	475	1019	-	-	888	-	-
Mov Cap-2 Maneuver	70	108	-	102	119	-	-	-	-	-	-	-
Stage 1	391	357	-	461	467	-	-	-	-	-	-	-
Stage 2	320	434	-	335	355	-	-	-	-	-	-	-

Approach	EB	WB	NB	SB
HCM Control Delay, s	23.9	44.7	0	1.6
HCM LOS	C	E		

Minor Lane/Major Mvmt	NBL	NBT	NBR	EBLn1	WBLn1	WBLn2	SBL	SBT	SBR
Capacity (veh/h)	1019	-	-	201	102	475	888	-	-
HCM Lane V/C Ratio	0.001	-	-	0.052	0.667	0.229	0.127	-	-
HCM Control Delay (s)	8.5	0	-	23.9	92.6	14.8	9.6	-	-
HCM Lane LOS	A	A	-	C	F	B	A	-	-
HCM 95th %tile Q(veh)	0	-	-	0.2	3.4	0.9	0.4	-	-

Intersection						
Int Delay, s/veh	6.9					
Movement	EBT	EBR	WBL	WBT	NBL	NBR
Lane Configurations	↑	↑		↑	↑	↑
Traffic Vol, veh/h	136	342	32	127	355	34
Future Vol, veh/h	136	342	32	127	355	34
Conflicting Peds, #/hr	0	1	0	0	0	0
Sign Control	Free	Free	Free	Free	Stop	Stop
RT Channelized	-	None	-	None	-	None
Storage Length	-	200	-	-	0	0
Veh in Median Storage, #	0	-	-	0	0	-
Grade, %	0	-	-	0	0	-
Peak Hour Factor	88	88	80	80	100	100
Heavy Vehicles, %	2	2	2	2	2	2
Mvmt Flow	155	389	40	159	355	34

Major/Minor	Major1	Major2	Minor1		
Conflicting Flow All	0	0	545	0	395
Stage 1	-	-	-	-	156
Stage 2	-	-	-	-	239
Critical Hdwy	-	-	4.12	-	6.42
Critical Hdwy Stg 1	-	-	-	-	5.42
Critical Hdwy Stg 2	-	-	-	-	5.42
Follow-up Hdwy	-	-	2.218	-	3.518
Pot Cap-1 Maneuver	-	-	1024	-	610
Stage 1	-	-	-	-	872
Stage 2	-	-	-	-	801
Platoon blocked, %	-	-	-	-	-
Mov Cap-1 Maneuver	-	-	1023	-	583
Mov Cap-2 Maneuver	-	-	-	-	583
Stage 1	-	-	-	-	871
Stage 2	-	-	-	-	767

Approach	EB	WB	NB
HCM Control Delay, s	0	1.7	19.3
HCM LOS			C

Minor Lane/Major Mvmt	NBLn1	NBLn2	EBT	EBR	WBL	WBT
Capacity (veh/h)	583	889	-	-	1023	-
HCM Lane V/C Ratio	0.609	0.038	-	-	0.039	-
HCM Control Delay (s)	20.3	9.2	-	-	8.7	0
HCM Lane LOS	C	A	-	-	A	A
HCM 95th %tile Q(veh)	4.1	0.1	-	-	0.1	-

HCM 6th Signalized Intersection Summary      General Plan 2040 Project Altern. A Conditions  
 10: US 101 NB Off Ramp/Lakewood Drive & Old Redwood Highway      Timing Plan: Saturday Midday Peak

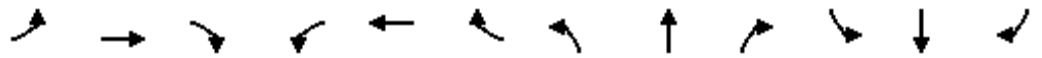

Movement	EBL	EBT	EBR	WBL	WBT	WBR	NBL	NBT	NBR	SBL	SBT	SBR
Lane Configurations	↔↔	↑			↑↑		↔	↔↔		↔↔		↔
Traffic Volume (veh/h)	372	472	0	0	719	357	415	393	185	316	0	908
Future Volume (veh/h)	372	472	0	0	719	357	415	393	185	316	0	908
Initial Q (Qb), veh	0	0	0	0	0	0	0	0	0	0	0	0
Ped-Bike Adj(A_pbT)	1.00		1.00	1.00		0.98	1.00		1.00	1.00		1.00
Parking Bus, Adj	1.00	1.00	1.00	1.00	1.00	1.00	1.00	1.00	1.00	1.00	1.00	1.00
Work Zone On Approach		No			No			No			No	
Adj Sat Flow, veh/h/ln	1870	1870	0	0	1870	1870	1870	1870	1870	1870	0	1870
Adj Flow Rate, veh/h	392	497	0	0	808	401	338	520	189	359	0	0
Peak Hour Factor	0.95	0.95	0.95	0.89	0.89	0.89	0.98	0.98	0.98	0.88	0.88	0.88
Percent Heavy Veh, %	2	2	0	0	2	2	2	2	2	2	0	2
Cap, veh/h	374	1101	0	0	953	470	501	737	267	0	0	0
Arrive On Green	0.11	0.59	0.00	0.00	0.42	0.42	0.28	0.28	0.28	0.00	0.00	0.00
Sat Flow, veh/h	3456	1870	0	0	2385	1131	1781	2621	948		0	
Grp Volume(v), veh/h	392	497	0	0	625	584	338	370	339		0.0	
Grp Sat Flow(s),veh/h/ln	1728	1870	0	0	1777	1646	1781	1870	1699			
Q Serve(g_s), s	7.5	10.3	0.0	0.0	22.0	22.2	11.7	12.3	12.4			
Cycle Q Clear(g_c), s	7.5	10.3	0.0	0.0	22.0	22.2	11.7	12.3	12.4			
Prop In Lane	1.00		0.00	0.00		0.69	1.00		0.56			
Lane Grp Cap(c), veh/h	374	1101	0	0	738	684	501	526	478			
V/C Ratio(X)	1.05	0.45	0.00	0.00	0.85	0.85	0.67	0.70	0.71			
Avail Cap(c_a), veh/h	374	1101	0	0	738	684	751	788	716			
HCM Platoon Ratio	1.00	1.00	1.00	1.00	1.00	1.00	1.00	1.00	1.00			
Upstream Filter(I)	1.00	1.00	0.00	0.00	1.00	1.00	1.00	1.00	1.00			
Uniform Delay (d), s/veh	30.9	8.0	0.0	0.0	18.3	18.3	22.1	22.3	22.3			
Incr Delay (d2), s/veh	59.7	1.3	0.0	0.0	11.5	12.8	1.6	1.7	1.9			
Initial Q Delay(d3),s/veh	0.0	0.0	0.0	0.0	0.0	0.0	0.0	0.0	0.0			
%ile BackOfQ(50%),veh/ln	6.0	3.7	0.0	0.0	10.2	9.8	4.8	5.3	4.9			
Unsig. Movement Delay, s/veh												
LnGrp Delay(d),s/veh	90.6	9.3	0.0	0.0	29.8	31.1	23.7	24.0	24.3			
LnGrp LOS	F	A	A	A	C	C	C	C	C			
Approach Vol, veh/h		889			1209			1047				
Approach Delay, s/veh		45.2			30.4			24.0				
Approach LOS		D			C			C				
Timer - Assigned Phs		2			5	6		8				
Phs Duration (G+Y+Rc), s		45.3			12.0	33.3		24.0				
Change Period (Y+Rc), s		4.5			4.5	4.5		4.5				
Max Green Setting (Gmax), s		40.8			7.5	28.8		29.2				
Max Q Clear Time (g_c+I1), s		12.3			9.5	24.2		14.4				
Green Ext Time (p_c), s		3.3			0.0	3.0		5.0				

**Intersection Summary**

HCM 6th Ctrl Delay	32.5
HCM 6th LOS	C

**Notes**

User approved volume balancing among the lanes for turning movement.  
 Unsignalized Delay for [SBR] is excluded from calculations of the approach delay and intersection delay.

HCM 6th Signalized Intersection Summary      General Plan 2040 Project Altern. A Conditions  
 12: US 101 SB On Ramp/US 101 SB Off Ramp & Old Redwood Highway      Timing Plan: Saturday Midday Peak

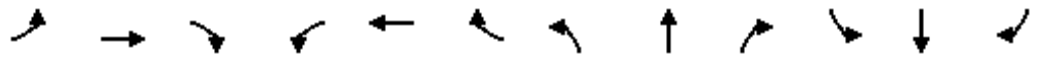

Movement	EBL	EBT	EBR	WBL	WBT	WBR	NBL	NBT	NBR	SBL	SBT	SBR
Lane Configurations		↑↑	↗	↘	↑↑					↘	↕	
Traffic Volume (veh/h)	0	713	543	632	1060	0	0	0	0	262	1	112
Future Volume (veh/h)	0	713	543	632	1060	0	0	0	0	262	1	112
Initial Q (Qb), veh	0	0	0	0	0	0				0	0	0
Ped-Bike Adj(A_pbT)	1.00		0.98	1.00		1.00				1.00		1.00
Parking Bus, Adj	1.00	1.00	1.00	1.00	1.00	1.00				1.00	1.00	1.00
Work Zone On Approach		No			No						No	
Adj Sat Flow, veh/h/ln	0	1870	1870	1870	1870	0				1870	1870	1870
Adj Flow Rate, veh/h	0	735	560	658	1104	0				260	146	0
Peak Hour Factor	0.97	0.97	0.97	0.96	0.96	0.96				0.72	0.72	0.72
Percent Heavy Veh, %	0	2	2	2	2	0				2	2	2
Cap, veh/h	0	1411	617	471	2579	0				260	273	
Arrive On Green	0.00	0.40	0.40	0.26	0.73	0.00				0.15	0.15	0.00
Sat Flow, veh/h	0	3647	1555	1781	3647	0				1781	1870	0
Grp Volume(v), veh/h	0	735	560	658	1104	0				260	146	0
Grp Sat Flow(s),veh/h/ln	0	1777	1555	1781	1777	0				1781	1870	0
Q Serve(g_s), s	0.0	11.0	23.8	18.5	8.7	0.0				10.2	5.1	0.0
Cycle Q Clear(g_c), s	0.0	11.0	23.8	18.5	8.7	0.0				10.2	5.1	0.0
Prop In Lane	0.00		1.00	1.00		0.00				1.00		0.00
Lane Grp Cap(c), veh/h	0	1411	617	471	2579	0				260	273	
V/C Ratio(X)	0.00	0.52	0.91	1.40	0.43	0.00				1.00	0.54	
Avail Cap(c_a), veh/h	0	1411	617	471	2579	0				260	273	
HCM Platoon Ratio	1.00	1.00	1.00	1.00	1.00	1.00				1.00	1.00	1.00
Upstream Filter(I)	0.00	1.00	1.00	1.00	1.00	0.00				1.00	1.00	0.00
Uniform Delay (d), s/veh	0.0	16.0	19.9	25.8	3.8	0.0				29.9	27.7	0.0
Incr Delay (d2), s/veh	0.0	1.4	19.4	191.5	0.5	0.0				56.3	2.1	0.0
Initial Q Delay(d3),s/veh	0.0	0.0	0.0	0.0	0.0	0.0				0.0	0.0	0.0
%ile BackOfQ(50%),veh/ln	0.0	4.3	10.9	32.2	2.0	0.0				8.2	2.3	0.0
Unsig. Movement Delay, s/veh												
LnGrp Delay(d),s/veh	0.0	17.4	39.3	217.3	4.3	0.0				86.2	29.8	0.0
LnGrp LOS	A	B	D	F	A	A				F	C	
Approach Vol, veh/h		1295			1762						406	
Approach Delay, s/veh		26.9			83.9						65.9	
Approach LOS		C			F						E	
Timer - Assigned Phs		2			5	6		8				
Phs Duration (G+Y+Rc), s		55.3			23.0	32.3		14.7				
Change Period (Y+Rc), s		4.5			4.5	4.5		4.5				
Max Green Setting (Gmax), s		50.8			18.5	27.8		10.2				
Max Q Clear Time (g_c+I1), s		10.7			20.5	25.8		12.2				
Green Ext Time (p_c), s		10.0			0.0	1.4		0.0				

**Intersection Summary**

HCM 6th Ctrl Delay	60.4
HCM 6th LOS	E

**Notes**

- User approved volume balancing among the lanes for turning movement.
- User approved ignoring U-Turning movement.
- Unsignalized Delay for [SBR] is excluded from calculations of the approach delay and intersection delay.

Queues  
1: Old Redwood Hwy & Shiloh Road

General Plan 2040 Project Altern. A Conditions

Timing Plan: A.M. PEAK



Lane Group	EBL	EBT	EBR	WBT	WBR	NBL	NBT	NBR	SBL	SBT	SBR
Lane Group Flow (vph)	386	383	543	317	33	391	335	19	62	564	468
v/c Ratio	0.88	0.83	0.86	0.81	0.08	1.88	0.51	0.03	0.72	1.06	0.87
Control Delay	67.9	61.5	32.6	62.6	0.4	443.1	35.9	0.1	100.8	99.9	46.9
Queue Delay	0.0	0.0	0.0	0.0	0.0	0.0	0.0	0.0	0.0	0.0	0.0
Total Delay	67.9	61.5	32.6	62.6	0.4	443.1	35.9	0.1	100.8	99.9	46.9
Queue Length 50th (ft)	296	290	182	242	0	~474	209	0	50	~494	258
Queue Length 95th (ft)	#441	#417	280	340	0	#730	337	0	#126	#729	#442
Internal Link Dist (ft)		1709		528			668			695	
Turn Bay Length (ft)	375		140		50	200		98	130		93
Base Capacity (vph)	439	462	635	571	562	208	659	610	86	530	541
Starvation Cap Reductn	0	0	0	0	0	0	0	0	0	0	0
Spillback Cap Reductn	0	0	0	0	0	0	0	0	0	0	0
Storage Cap Reductn	0	0	0	0	0	0	0	0	0	0	0
Reduced v/c Ratio	0.88	0.83	0.86	0.56	0.06	1.88	0.51	0.03	0.72	1.06	0.87

Intersection Summary

~ Volume exceeds capacity, queue is theoretically infinite.

Queue shown is maximum after two cycles.

# 95th percentile volume exceeds capacity, queue may be longer.

Queue shown is maximum after two cycles.



Queues  
2: Shiloh Road & Hembree Ln

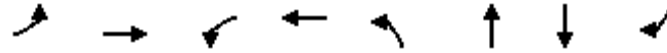

Lane Group	EBL	EBT	WBL	WBT	NBL	NBT	SBT	SBR
Lane Group Flow (vph)	353	1146	49	985	49	27	155	606
v/c Ratio	0.51	0.98	0.42	0.63	0.42	0.21	0.73	1.00
Control Delay	34.1	40.8	51.9	20.0	51.9	28.9	58.9	59.3
Queue Delay	0.0	11.5	0.0	0.0	0.0	0.0	0.0	0.0
Total Delay	34.1	52.3	51.9	20.0	51.9	28.9	58.9	59.3
Queue Length 50th (ft)	94	~719	27	209	27	6	87	~279
Queue Length 95th (ft)	134	#929	#65	273	#65	32	#189	#559
Internal Link Dist (ft)		222		1709		136	301	
Turn Bay Length (ft)			100					
Base Capacity (vph)	698	1170	116	1741	116	126	213	608
Starvation Cap Reductn	0	53	0	0	0	0	0	0
Spillback Cap Reductn	0	0	0	0	0	0	0	0
Storage Cap Reductn	0	0	0	0	0	0	0	0
Reduced v/c Ratio	0.51	1.03	0.42	0.57	0.42	0.21	0.73	1.00

Intersection Summary

- ~ Volume exceeds capacity, queue is theoretically infinite.  
Queue shown is maximum after two cycles.
- # 95th percentile volume exceeds capacity, queue may be longer.  
Queue shown is maximum after two cycles.

Queues  
3: US 101 NB Off-Ramp & Shiloh Road

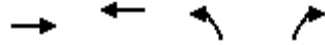

Lane Group	EBT	WBT	NBL	NBR
Lane Group Flow (vph)	804	1226	1070	791
v/c Ratio	0.50	1.44	1.40	0.61
Control Delay	15.0	225.6	212.4	14.1
Queue Delay	0.0	0.0	0.0	0.0
Total Delay	15.0	225.6	212.4	14.1
Queue Length 50th (ft)	125	~755	~651	109
Queue Length 95th (ft)	173	#986	#681	125
Internal Link Dist (ft)	106	291	689	
Turn Bay Length (ft)				265
Base Capacity (vph)	1622	853	762	1307
Starvation Cap Reductn	0	0	0	0
Spillback Cap Reductn	0	0	0	0
Storage Cap Reductn	0	0	0	0
Reduced v/c Ratio	0.50	1.44	1.40	0.61

Intersection Summary

- ~ Volume exceeds capacity, queue is theoretically infinite.  
Queue shown is maximum after two cycles.
- # 95th percentile volume exceeds capacity, queue may be longer.  
Queue shown is maximum after two cycles.

Queues  
4: Shiloh Road & US 101 SB Off-Ramp

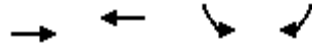

Lane Group	EBT	WBT	SBL	SBR
Lane Group Flow (vph)	454	1267	337	200
v/c Ratio	0.34	0.96	0.96	0.50
Control Delay	5.5	29.7	77.6	20.8
Queue Delay	0.0	0.0	0.0	0.0
Total Delay	5.5	29.7	77.6	20.8
Queue Length 50th (ft)	79	523	~196	46
Queue Length 95th (ft)	119	#956	#368	113
Internal Link Dist (ft)	145	226	406	
Turn Bay Length (ft)				275
Base Capacity (vph)	1409	1409	350	398
Starvation Cap Reductn	0	0	0	0
Spillback Cap Reductn	0	0	0	0
Storage Cap Reductn	0	0	0	0
Reduced v/c Ratio	0.32	0.90	0.96	0.50

Intersection Summary

- ~ Volume exceeds capacity, queue is theoretically infinite.  
Queue shown is maximum after two cycles.
- # 95th percentile volume exceeds capacity, queue may be longer.  
Queue shown is maximum after two cycles.

Queues  
6: Conde Lane & Shiloh Road

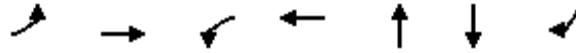

Lane Group	EBL	EBT	WBL	WBT	NBT	SBT	SBR
Lane Group Flow (vph)	58	566	9	1356	22	422	31
v/c Ratio	0.28	0.25	0.05	0.69	0.09	1.55	0.03
Control Delay	37.6	7.7	35.8	15.7	20.8	290.6	11.2
Queue Delay	0.0	0.0	0.0	0.0	0.0	0.0	0.0
Total Delay	37.6	7.7	35.8	15.7	20.8	290.6	11.2
Queue Length 50th (ft)	24	32	4	196	2	~271	6
Queue Length 95th (ft)	67	132	18	370	13	#505	22
Internal Link Dist (ft)		735		1001	338	442	
Turn Bay Length (ft)	90		127				40
Base Capacity (vph)	223	2291	198	1979	779	273	911
Starvation Cap Reductn	0	0	0	0	0	0	0
Spillback Cap Reductn	0	0	0	0	0	0	0
Storage Cap Reductn	0	0	0	0	0	0	0
Reduced v/c Ratio	0.26	0.25	0.05	0.69	0.03	1.55	0.03

Intersection Summary

~ Volume exceeds capacity, queue is theoretically infinite.  
Queue shown is maximum after two cycles.

# 95th percentile volume exceeds capacity, queue may be longer.  
Queue shown is maximum after two cycles.

Queues

10: US 101 NB Off Ramp/Lakewood Drive & Old Redwood Highway

General Plan 2040 Project Altern. A Conditions

Timing Plan: A.M. PEAK



Lane Group	EBL	EBT	WBT	NBL	NBT	SBL	SBR
Lane Group Flow (vph)	311	751	994	212	422	287	763
v/c Ratio	0.79	0.78	0.82	0.61	0.57	0.93	0.99
Control Delay	50.6	24.2	30.3	35.0	27.0	75.7	47.3
Queue Delay	0.0	0.0	0.0	0.0	0.0	0.0	0.0
Total Delay	50.6	24.2	30.3	35.0	27.0	75.7	47.3
Queue Length 50th (ft)	77	279	221	102	89	73	266
Queue Length 95th (ft)	#145	#522	#310	173	134	#163	#511
Internal Link Dist (ft)		146	537		636		
Turn Bay Length (ft)	155			270		120	
Base Capacity (vph)	396	961	1218	599	1236	308	771
Starvation Cap Reductn	0	0	0	0	0	0	0
Spillback Cap Reductn	0	0	0	0	0	0	0
Storage Cap Reductn	0	0	0	0	0	0	0
Reduced v/c Ratio	0.79	0.78	0.82	0.35	0.34	0.93	0.99

Intersection Summary

# 95th percentile volume exceeds capacity, queue may be longer.  
 Queue shown is maximum after two cycles.

Queues

12: US 101 SB On Ramp/US 101 SB Off Ramp & Old Redwood Highway



Lane Group	EBT	EBR	WBL	WBT	SBL	SBT
Lane Group Flow (vph)	760	885	628	834	205	201
v/c Ratio	0.63	1.15	0.98	0.31	0.98	0.58
Control Delay	25.1	101.9	58.5	3.6	94.8	15.0
Queue Delay	0.0	0.0	0.0	0.0	0.0	0.0
Total Delay	25.1	101.9	58.5	3.6	94.8	15.0
Queue Length 50th (ft)	165	~400	304	55	109	10
Queue Length 95th (ft)	224	#624	#511	73	#210	55
Internal Link Dist (ft)	343			451		751
Turn Bay Length (ft)			250		420	
Base Capacity (vph)	1203	767	641	2663	210	346
Starvation Cap Reductn	0	0	0	0	0	0
Spillback Cap Reductn	0	0	0	0	0	0
Storage Cap Reductn	0	0	0	0	0	0
Reduced v/c Ratio	0.63	1.15	0.98	0.31	0.98	0.58

Intersection Summary

~ Volume exceeds capacity, queue is theoretically infinite.

Queue shown is maximum after two cycles.

# 95th percentile volume exceeds capacity, queue may be longer.

Queue shown is maximum after two cycles.

Queues  
1: Old Redwood Hwy & Shiloh Road

General Plan 2040 Project Altern. A Conditions

Timing Plan: P.M. Peak



Lane Group	EBL	EBT	EBR	WBT	WBR	NBL	NBT	NBR	SBL	SBT	SBR
Lane Group Flow (vph)	327	575	693	534	77	717	610	47	108	591	285
v/c Ratio	0.82	1.37	1.22	1.02	0.15	3.77	1.02	0.09	1.38	1.22	0.60
Control Delay	67.1	220.3	140.4	92.8	3.4	1276.8	86.1	2.3	279.8	160.3	33.0
Queue Delay	0.0	0.0	0.0	0.0	0.0	0.0	0.0	0.0	0.0	0.0	0.0
Total Delay	67.1	220.3	140.4	92.8	3.4	1276.8	86.1	2.3	279.8	160.3	33.0
Queue Length 50th (ft)	274	~664	~547	~497	0	~1132	~564	0	~125	~636	139
Queue Length 95th (ft)	#424	#893	#791	#721	21	#1374	#797	11	#249	#867	238
Internal Link Dist (ft)		1709		528			668			695	
Turn Bay Length (ft)	375		140		50	200		98	130		93
Base Capacity (vph)	399	420	569	522	511	190	600	550	78	483	477
Starvation Cap Reductn	0	0	0	0	0	0	0	0	0	0	0
Spillback Cap Reductn	0	0	0	0	0	0	0	0	0	0	0
Storage Cap Reductn	0	0	0	0	0	0	0	0	0	0	0
Reduced v/c Ratio	0.82	1.37	1.22	1.02	0.15	3.77	1.02	0.09	1.38	1.22	0.60

Intersection Summary

~ Volume exceeds capacity, queue is theoretically infinite.

Queue shown is maximum after two cycles.

# 95th percentile volume exceeds capacity, queue may be longer.

Queue shown is maximum after two cycles.

## Queues

## General Plan 2040 Project Altern. A Conditions

## 2: Shiloh Road &amp; Hembree Ln

Timing Plan: P.M. Peak

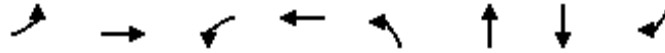

Lane Group	EBL	EBT	WBL	WBT	NBL	NBT	SBT	SBR
Lane Group Flow (vph)	703	1499	110	1453	111	149	194	554
v/c Ratio	1.08	1.37	1.02	0.90	1.03	0.68	0.98	1.07
Control Delay	96.8	195.8	136.9	31.3	139.2	27.8	103.0	85.5
Queue Delay	0.0	0.1	0.0	0.0	0.0	0.0	0.0	0.0
Total Delay	96.8	195.9	136.9	31.3	139.2	27.8	103.0	85.5
Queue Length 50th (ft)	~233	~1149	~65	382	~66	12	112	~261
Queue Length 95th (ft)	#342	#1410	#171	460	#173	#91	#246	#535
Internal Link Dist (ft)		222		1709		136	301	
Turn Bay Length (ft)			100					
Base Capacity (vph)	648	1091	108	1615	108	219	197	517
Starvation Cap Reductn	0	22	0	0	0	0	0	0
Spillback Cap Reductn	0	0	0	0	0	0	0	0
Storage Cap Reductn	0	0	0	0	0	0	0	0
Reduced v/c Ratio	1.08	1.40	1.02	0.90	1.03	0.68	0.98	1.07

## Intersection Summary

~ Volume exceeds capacity, queue is theoretically infinite.

Queue shown is maximum after two cycles.

# 95th percentile volume exceeds capacity, queue may be longer.

Queue shown is maximum after two cycles.



Queues  
3: US 101 NB Off-Ramp & Shiloh Road



Lane Group	EBT	WBT	NBL	NBR
Lane Group Flow (vph)	1036	1154	771	1174
v/c Ratio	0.64	1.35	1.01	0.94
Control Delay	17.2	188.7	58.8	34.0
Queue Delay	0.0	0.0	0.0	0.0
Total Delay	17.2	188.7	58.8	34.0
Queue Length 50th (ft)	176	~687	~339	254
Queue Length 95th (ft)	238	#914	#571	#411
Internal Link Dist (ft)	106	291	689	
Turn Bay Length (ft)				265
Base Capacity (vph)	1622	853	762	1252
Starvation Cap Reductn	0	0	0	0
Spillback Cap Reductn	0	0	0	0
Storage Cap Reductn	0	0	0	0
Reduced v/c Ratio	0.64	1.35	1.01	0.94

Intersection Summary

- ~ Volume exceeds capacity, queue is theoretically infinite.  
Queue shown is maximum after two cycles.
- # 95th percentile volume exceeds capacity, queue may be longer.  
Queue shown is maximum after two cycles.

Queues  
4: Shiloh Road & US 101 SB Off-Ramp

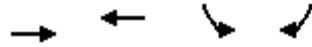

Lane Group	EBT	WBT	SBL	SBR
Lane Group Flow (vph)	755	1129	538	101
v/c Ratio	0.61	0.91	1.33	0.23
Control Delay	9.2	22.9	195.0	8.6
Queue Delay	0.0	0.0	0.0	0.0
Total Delay	9.2	22.9	195.0	8.6
Queue Length 50th (ft)	168	379	~359	0
Queue Length 95th (ft)	243	617	#638	41
Internal Link Dist (ft)	145	226	406	
Turn Bay Length (ft)				275
Base Capacity (vph)	1575	1575	404	431
Starvation Cap Reductn	0	0	0	0
Spillback Cap Reductn	0	0	0	0
Storage Cap Reductn	0	0	0	0
Reduced v/c Ratio	0.48	0.72	1.33	0.23

Intersection Summary

- ~ Volume exceeds capacity, queue is theoretically infinite.  
Queue shown is maximum after two cycles.
- # 95th percentile volume exceeds capacity, queue may be longer.  
Queue shown is maximum after two cycles.

Queues  
6: Conde Lane & Shiloh Road

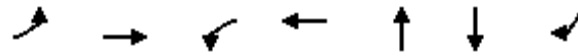

Lane Group	EBL	EBT	WBL	WBT	NBT	SBT	SBR
Lane Group Flow (vph)	88	838	11	1399	34	445	74
v/c Ratio	0.45	0.38	0.06	0.77	0.14	1.75	0.09
Control Delay	44.0	9.5	37.1	19.7	19.5	381.4	12.6
Queue Delay	0.0	0.0	0.0	0.0	0.0	0.0	0.0
Total Delay	44.0	9.5	37.1	19.7	19.5	381.4	12.6
Queue Length 50th (ft)	46	108	6	326	4	~384	22
Queue Length 95th (ft)	91	200	19	342	18	#549	44
Internal Link Dist (ft)		735		1001	338	442	
Turn Bay Length (ft)	90		127				40
Base Capacity (vph)	207	2236	184	1822	728	254	844
Starvation Cap Reductn	0	0	0	0	0	0	0
Spillback Cap Reductn	0	0	0	0	0	0	0
Storage Cap Reductn	0	0	0	0	0	0	0
Reduced v/c Ratio	0.43	0.37	0.06	0.77	0.05	1.75	0.09

Intersection Summary

~ Volume exceeds capacity, queue is theoretically infinite.  
Queue shown is maximum after two cycles.

# 95th percentile volume exceeds capacity, queue may be longer.  
Queue shown is maximum after two cycles.

Queues

10: US 101 NB Off Ramp/Lakewood Drive & Old Redwood Highway



Lane Group	EBL	EBT	WBT	NBL	NBT	SBL	SBR
Lane Group Flow (vph)	355	854	1137	499	990	402	644
v/c Ratio	1.03	1.03	1.07	0.96	0.92	1.51	0.73
Control Delay	99.4	64.7	79.2	63.3	42.2	277.9	17.3
Queue Delay	0.0	0.0	0.0	0.0	0.0	0.0	0.0
Total Delay	99.4	64.7	79.2	63.3	42.2	277.9	17.3
Queue Length 50th (ft)	~112	~523	~369	303	276	~165	177
Queue Length 95th (ft)	#189	#706	#499	#523	#409	#256	320
Internal Link Dist (ft)		146	537		636		
Turn Bay Length (ft)	155			270		120	
Base Capacity (vph)	343	832	1061	518	1075	267	878
Starvation Cap Reductn	0	0	0	0	0	0	0
Spillback Cap Reductn	0	0	0	0	0	0	0
Storage Cap Reductn	0	0	0	0	0	0	0
Reduced v/c Ratio	1.03	1.03	1.07	0.96	0.92	1.51	0.73

Intersection Summary

~ Volume exceeds capacity, queue is theoretically infinite.

Queue shown is maximum after two cycles.

# 95th percentile volume exceeds capacity, queue may be longer.

Queue shown is maximum after two cycles.

Queues

12: US 101 SB On Ramp/US 101 SB Off Ramp & Old Redwood Highway



Lane Group	EBT	EBR	WBL	WBT	SBL	SBT
Lane Group Flow (vph)	651	533	498	1260	372	344
v/c Ratio	0.46	0.60	1.09	0.50	1.51	1.11
Control Delay	16.8	6.4	98.8	5.3	274.7	107.1
Queue Delay	0.0	0.0	0.0	0.0	0.0	0.0
Total Delay	16.8	6.4	98.8	5.3	274.7	107.1
Queue Length 50th (ft)	105	24	~248	101	~240	~140
Queue Length 95th (ft)	149	98	#412	133	#361	#262
Internal Link Dist (ft)	343			451		751
Turn Bay Length (ft)			250		420	
Base Capacity (vph)	1410	887	455	2522	247	311
Starvation Cap Reductn	0	0	0	0	0	0
Spillback Cap Reductn	0	0	0	0	0	0
Storage Cap Reductn	0	0	0	0	0	0
Reduced v/c Ratio	0.46	0.60	1.09	0.50	1.51	1.11

Intersection Summary

~ Volume exceeds capacity, queue is theoretically infinite.

Queue shown is maximum after two cycles.

# 95th percentile volume exceeds capacity, queue may be longer.

Queue shown is maximum after two cycles.

Queues  
1: Old Redwood Hwy & Shiloh Road

General Plan 2040 Project Altern. A Conditions  
Timing Plan: Saturday Midday Peak



Lane Group	EBL	EBT	EBR	WBT	WBR	NBL	NBT	NBR	SBL	SBT	SBR
Lane Group Flow (vph)	204	569	346	643	88	341	378	38	91	313	292
v/c Ratio	0.48	1.27	0.72	1.15	0.16	1.74	0.74	0.08	1.18	0.81	0.65
Control Delay	46.9	176.4	36.6	127.8	3.7	388.0	50.8	0.3	213.2	64.0	27.2
Queue Delay	0.0	0.0	0.0	0.0	0.0	0.0	0.0	0.0	0.0	0.0	0.0
Total Delay	46.9	176.4	36.6	127.8	3.7	388.0	50.8	0.3	213.2	64.0	27.2
Queue Length 50th (ft)	145	~591	161	~625	0	~417	282	0	~90	246	99
Queue Length 95th (ft)	236	#867	292	#868	20	#648	394	0	#217	351	197
Internal Link Dist (ft)		1709		528			668			695	
Turn Bay Length (ft)	375		140		50	200		98	130		93
Base Capacity (vph)	427	449	478	558	555	196	641	586	77	516	541
Starvation Cap Reductn	0	0	0	0	0	0	0	0	0	0	0
Spillback Cap Reductn	0	0	0	0	0	0	0	0	0	0	0
Storage Cap Reductn	0	0	0	0	0	0	0	0	0	0	0
Reduced v/c Ratio	0.48	1.27	0.72	1.15	0.16	1.74	0.59	0.06	1.18	0.61	0.54

Intersection Summary

~ Volume exceeds capacity, queue is theoretically infinite.

Queue shown is maximum after two cycles.

# 95th percentile volume exceeds capacity, queue may be longer.

Queue shown is maximum after two cycles.

Queues  
2: Shiloh Road & Hembree Ln

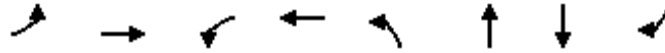

Lane Group	EBL	EBT	WBL	WBT	NBL	NBT	SBT	SBR
Lane Group Flow (vph)	977	989	110	1090	111	149	270	941
v/c Ratio	1.44	0.94	0.97	0.72	0.98	0.67	1.31	1.67
Control Delay	234.8	34.8	122.9	21.9	125.3	26.9	203.5	330.7
Queue Delay	0.0	2.3	0.0	0.0	0.0	0.0	0.0	0.0
Total Delay	234.8	37.1	122.9	21.9	125.3	26.9	203.5	330.7
Queue Length 50th (ft)	~402	455	~65	234	~66	12	~205	~779
Queue Length 95th (ft)	#522	#765	#171	306	#173	#91	#357	#1015
Internal Link Dist (ft)		222		1709		136	301	
Turn Bay Length (ft)			100					
Base Capacity (vph)	680	1141	113	1676	113	223	206	564
Starvation Cap Reductn	0	69	0	0	0	0	0	0
Spillback Cap Reductn	0	0	0	0	0	0	0	0
Storage Cap Reductn	0	0	0	0	0	0	0	0
Reduced v/c Ratio	1.44	0.92	0.97	0.65	0.98	0.67	1.31	1.67

Intersection Summary

- ~ Volume exceeds capacity, queue is theoretically infinite.  
Queue shown is maximum after two cycles.
- # 95th percentile volume exceeds capacity, queue may be longer.  
Queue shown is maximum after two cycles.

Queues  
3: US 101 NB Off-Ramp & Shiloh Road

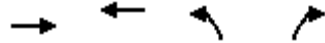

Lane Group	EBT	WBT	NBL	NBR
Lane Group Flow (vph)	791	1397	547	1117
v/c Ratio	0.48	1.62	0.76	0.89
Control Delay	14.7	307.0	25.6	26.7
Queue Delay	0.0	0.0	0.0	0.0
Total Delay	14.7	307.0	25.6	26.7
Queue Length 50th (ft)	124	~923	195	209
Queue Length 95th (ft)	172	#1143	312	#351
Internal Link Dist (ft)	106	291	689	
Turn Bay Length (ft)				265
Base Capacity (vph)	1636	861	768	1316
Starvation Cap Reductn	0	0	0	0
Spillback Cap Reductn	0	0	0	0
Storage Cap Reductn	0	0	0	0
Reduced v/c Ratio	0.48	1.62	0.71	0.85

Intersection Summary

~ Volume exceeds capacity, queue is theoretically infinite.  
Queue shown is maximum after two cycles.

# 95th percentile volume exceeds capacity, queue may be longer.  
Queue shown is maximum after two cycles.



Queues  
4: Shiloh Road & US 101 SB Off-Ramp

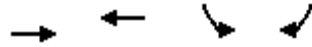

Lane Group	EBT	WBT	SBL	SBR
Lane Group Flow (vph)	442	827	606	328
v/c Ratio	0.44	0.82	1.15	0.51
Control Delay	8.8	18.0	114.7	9.7
Queue Delay	0.0	0.0	0.0	0.0
Total Delay	8.8	18.0	114.7	9.7
Queue Length 50th (ft)	79	202	~244	21
Queue Length 95th (ft)	126	324	#381	47
Internal Link Dist (ft)	145	226	406	
Turn Bay Length (ft)				275
Base Capacity (vph)	1825	1825	525	640
Starvation Cap Reductn	0	0	0	0
Spillback Cap Reductn	0	0	0	0
Storage Cap Reductn	0	0	0	0
Reduced v/c Ratio	0.24	0.45	1.15	0.51

Intersection Summary

- ~ Volume exceeds capacity, queue is theoretically infinite.  
Queue shown is maximum after two cycles.
- # 95th percentile volume exceeds capacity, queue may be longer.  
Queue shown is maximum after two cycles.

Queues  
6: Conde Lane & Shiloh Road

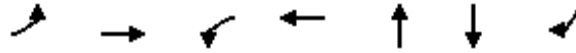

Lane Group	EBL	EBT	WBL	WBT	NBT	SBT	SBR
Lane Group Flow (vph)	45	578	14	1006	18	373	53
v/c Ratio	0.16	0.32	0.05	0.67	0.05	0.99	0.08
Control Delay	33.0	9.7	33.5	15.9	0.2	80.1	13.0
Queue Delay	0.0	0.0	0.0	0.0	0.0	0.0	0.0
Total Delay	33.0	9.7	33.5	15.9	0.2	80.1	13.0
Queue Length 50th (ft)	13	35	4	125	0	~143	10
Queue Length 95th (ft)	56	142	26	263	0	#392	31
Internal Link Dist (ft)		735		1001	338	442	
Turn Bay Length (ft)	90		127				40
Base Capacity (vph)	290	2693	272	2516	1073	375	1182
Starvation Cap Reductn	0	0	0	0	0	0	0
Spillback Cap Reductn	0	0	0	0	0	0	0
Storage Cap Reductn	0	0	0	0	0	0	0
Reduced v/c Ratio	0.16	0.21	0.05	0.40	0.02	0.99	0.04

Intersection Summary

~ Volume exceeds capacity, queue is theoretically infinite.

Queue shown is maximum after two cycles.

# 95th percentile volume exceeds capacity, queue may be longer.

Queue shown is maximum after two cycles.

Queues

General Plan 2040 Project Altern. A Conditions

10: US 101 NB Off Ramp/Lakewood Drive & Old Redwood Highway Timing Plan: Saturday Midday Peak



Lane Group	EBL	EBT	WBT	NBL	NBT	SBL	SBR
Lane Group Flow (vph)	392	497	1209	338	675	359	1032
v/c Ratio	1.31	0.56	1.02	0.73	0.70	1.29	1.27
Control Delay	195.7	20.2	59.0	37.9	28.9	188.2	152.3
Queue Delay	0.0	0.0	0.0	0.0	0.0	0.0	0.0
Total Delay	195.7	20.2	59.0	37.9	28.9	188.2	152.3
Queue Length 50th (ft)	~150	197	~370	180	162	~135	~645
Queue Length 95th (ft)	#244	307	#506	285	224	#220	#859
Internal Link Dist (ft)		146	537		636		
Turn Bay Length (ft)	155			270		120	
Base Capacity (vph)	299	884	1188	547	1134	279	812
Starvation Cap Reductn	0	0	0	0	0	0	0
Spillback Cap Reductn	0	0	0	0	0	0	0
Storage Cap Reductn	0	0	0	0	0	0	0
Reduced v/c Ratio	1.31	0.56	1.02	0.62	0.60	1.29	1.27

Intersection Summary

~ Volume exceeds capacity, queue is theoretically infinite.

Queue shown is maximum after two cycles.

# 95th percentile volume exceeds capacity, queue may be longer.

Queue shown is maximum after two cycles.

Queues

General Plan 2040 Project Altern. A Conditions

12: US 101 SB On Ramp/US 101 SB Off Ramp & Old Redwood Highway Timing Plan: Saturday Midday Peak



Lane Group	EBT	EBR	WBL	WBT	SBL	SBT
Lane Group Flow (vph)	735	560	658	1104	269	252
v/c Ratio	0.52	0.65	1.41	0.43	1.10	0.81
Control Delay	17.7	8.7	222.1	4.4	120.4	39.3
Queue Delay	0.0	0.0	0.0	0.0	0.0	0.0
Total Delay	17.7	8.7	222.1	4.4	120.4	39.3
Queue Length 50th (ft)	123	42	~389	77	~141	67
Queue Length 95th (ft)	171	136	#579	105	#203	#104
Internal Link Dist (ft)	343			451		751
Turn Bay Length (ft)			250		420	
Base Capacity (vph)	1405	863	467	2568	244	313
Starvation Cap Reductn	0	0	0	0	0	0
Spillback Cap Reductn	0	0	0	0	0	0
Storage Cap Reductn	0	0	0	0	0	0
Reduced v/c Ratio	0.52	0.65	1.41	0.43	1.10	0.81

Intersection Summary

~ Volume exceeds capacity, queue is theoretically infinite.

























Queue shown is maximum after two cycles.

# 95th percentile volume exceeds capacity, queue may be longer.

Queue shown is maximum after two cycles.

HCM 6th Signalized Intersection Summary  
 1: Old Redwood Hwy & Shiloh Road

GP 2040+Project Alternative A\_Mitigations  
 Timing Plan: A.M. PEAK

												
Movement	EBL	EBT	EBR	WBL	WBT	WBR	NBL	NBT	NBR	SBL	SBT	SBR
Lane Configurations												
Traffic Volume (veh/h)	313	310	440	40	242	29	364	312	18	53	479	398
Future Volume (veh/h)	313	310	440	40	242	29	364	312	18	53	479	398
Initial Q (Qb), veh	0	0	0	0	0	0	0	0	0	0	0	0
Ped-Bike Adj(A_pbT)	1.00		1.00	1.00		1.00	1.00		1.00	1.00		0.99
Parking Bus, Adj	1.00	1.00	1.00	1.00	1.00	1.00	1.00	1.00	1.00	1.00	1.00	1.00
Work Zone On Approach		No			No			No			No	
Adj Sat Flow, veh/h/ln	1870	1870	1870	1870	1870	1870	1870	1870	1870	1870	1870	1870
Adj Flow Rate, veh/h	313	310	440	40	242	29	364	312	18	53	479	398
Peak Hour Factor	1.00	1.00	1.00	1.00	1.00	1.00	1.00	1.00	1.00	1.00	1.00	1.00
Percent Heavy Veh, %	2	2	2	2	2	2	2	2	2	2	2	2
Cap, veh/h	360	1100	490	104	588	262	453	1337	597	104	1078	475
Arrive On Green	0.20	0.31	0.31	0.06	0.17	0.17	0.13	0.38	0.38	0.06	0.30	0.30
Sat Flow, veh/h	1781	3554	1585	1781	3554	1585	3456	3554	1585	1781	3554	1565
Grp Volume(v), veh/h	313	310	440	40	242	29	364	312	18	53	479	398
Grp Sat Flow(s),veh/h/ln	1781	1777	1585	1781	1777	1585	1728	1777	1585	1781	1777	1565
Q Serve(g_s), s	14.6	5.7	22.8	1.9	5.2	1.3	8.8	5.2	0.6	2.5	9.3	20.4
Cycle Q Clear(g_c), s	14.6	5.7	22.8	1.9	5.2	1.3	8.8	5.2	0.6	2.5	9.3	20.4
Prop In Lane	1.00		1.00	1.00		1.00	1.00		1.00	1.00		1.00
Lane Grp Cap(c), veh/h	360	1100	490	104	588	262	453	1337	597	104	1078	475
V/C Ratio(X)	0.87	0.28	0.90	0.39	0.41	0.11	0.80	0.23	0.03	0.51	0.44	0.84
Avail Cap(c_a), veh/h	622	1257	561	788	1588	708	587	1774	791	139	1447	637
HCM Platoon Ratio	1.00	1.00	1.00	1.00	1.00	1.00	1.00	1.00	1.00	1.00	1.00	1.00
Upstream Filter(I)	1.00	1.00	1.00	1.00	1.00	1.00	1.00	1.00	1.00	1.00	1.00	1.00
Uniform Delay (d), s/veh	33.2	22.4	28.4	39.0	32.1	30.5	36.3	18.3	16.9	39.3	24.1	28.0
Incr Delay (d2), s/veh	6.6	0.1	15.8	2.3	0.5	0.2	6.1	0.1	0.0	3.9	0.3	7.3
Initial Q Delay(d3),s/veh	0.0	0.0	0.0	0.0	0.0	0.0	0.0	0.0	0.0	0.0	0.0	0.0
%ile BackOfQ(50%),veh/ln	6.6	2.3	10.0	0.8	2.2	0.5	3.9	1.9	0.2	1.2	3.7	7.9
Unsig. Movement Delay, s/veh												
LnGrp Delay(d),s/veh	39.8	22.6	44.2	41.3	32.6	30.7	42.4	18.4	16.9	43.1	24.4	35.3
LnGrp LOS	D	C	D	D	C	C	D	B	B	D	C	D
Approach Vol, veh/h		1063			311			694			930	
Approach Delay, s/veh		36.6			33.5			31.0			30.1	
Approach LOS		D			C			C			C	
Timer - Assigned Phs	1	2	3	4	5	6	7	8				
Phs Duration (G+Y+Rc), s	9.5	31.1	14.8	30.6	21.9	18.7	8.5	36.8				
Change Period (Y+Rc), s	4.5	4.5	3.5	4.5	4.5	4.5	3.5	4.5				
Max Green Setting (Gmax), s	38.0	30.4	14.6	35.0	30.0	38.4	6.7	42.9				
Max Q Clear Time (g_c+I1), s	3.9	24.8	10.8	22.4	16.6	7.2	4.5	7.2				
Green Ext Time (p_c), s	0.1	1.8	0.5	3.7	0.8	1.6	0.0	2.0				
<b>Intersection Summary</b>												
HCM 6th Ctrl Delay			33.0									
HCM 6th LOS			C									

HCM 6th Signalized Intersection Summary  
2: Shiloh Road & Hembree Ln

GP 2040+Project Alternative A\_Mitigations  
Timing Plan: A.M. PEAK



Movement	EBL	EBT	EBR	WBL	WBT	WBR	NBL	NBT	NBR	SBL	SBT	SBR
Lane Configurations	↖↗	↑↓		↖↗	↑↓		↖	↓		↖	↑	↗↖
Traffic Volume (veh/h)	311	918	103	49	865	90	49	11	16	129	18	570
Future Volume (veh/h)	311	918	103	49	865	90	49	11	16	129	18	570
Initial Q (Qb), veh	0	0	0	0	0	0	0	0	0	0	0	0
Ped-Bike Adj(A_pbT)	1.00		1.00	1.00		1.00	1.00		1.00	1.00		1.00
Parking Bus, Adj	1.00	1.00	1.00	1.00	1.00	1.00	1.00	1.00	1.00	1.00	1.00	1.00
Work Zone On Approach		No		No		No		No		No		No
Adj Sat Flow, veh/h/ln	1870	1870	1870	1870	1870	1870	1870	1870	1870	1870	1870	1870
Adj Flow Rate, veh/h	353	1043	103	49	892	93	49	11	16	137	18	606
Peak Hour Factor	0.88	0.88	1.00	1.00	0.97	0.97	1.00	1.00	1.00	0.94	1.00	0.94
Percent Heavy Veh, %	2	2	2	2	2	2	2	2	2	2	2	2
Cap, veh/h	475	1540	152	84	1238	129	149	65	95	195	226	721
Arrive On Green	0.14	0.47	0.47	0.05	0.38	0.38	0.08	0.10	0.10	0.11	0.12	0.12
Sat Flow, veh/h	3456	3267	322	1781	3248	339	1781	689	1002	1781	1870	2790
Grp Volume(v), veh/h	353	567	579	49	488	497	49	0	27	137	18	606
Grp Sat Flow(s),veh/h/ln	1728	1777	1812	1781	1777	1809	1781	0	1690	1781	1870	1395
Q Serve(g_s), s	5.7	14.3	14.3	1.6	13.6	13.6	1.5	0.0	0.8	4.3	0.5	7.0
Cycle Q Clear(g_c), s	5.7	14.3	14.3	1.6	13.6	13.6	1.5	0.0	0.8	4.3	0.5	7.0
Prop In Lane	1.00		0.18	1.00		0.19	1.00		0.59	1.00		1.00
Lane Grp Cap(c), veh/h	475	838	855	84	677	690	149	0	161	195	226	721
V/C Ratio(X)	0.74	0.68	0.68	0.58	0.72	0.72	0.33	0.00	0.17	0.70	0.08	0.84
Avail Cap(c_a), veh/h	598	1352	1379	200	1244	1267	200	0	161	246	226	721
HCM Platoon Ratio	1.00	1.00	1.00	1.00	1.00	1.00	1.00	1.00	1.00	1.00	1.00	1.00
Upstream Filter(I)	1.00	1.00	1.00	1.00	1.00	1.00	1.00	0.00	1.00	1.00	1.00	1.00
Uniform Delay (d), s/veh	24.0	11.9	11.9	27.0	15.3	15.3	25.0	0.0	24.1	24.8	22.6	20.3
Incr Delay (d2), s/veh	3.8	1.0	0.9	6.3	1.5	1.4	1.3	0.0	0.5	6.3	0.1	8.8
Initial Q Delay(d3),s/veh	0.0	0.0	0.0	0.0	0.0	0.0	0.0	0.0	0.0	0.0	0.0	0.0
%ile BackOfQ(50%),veh/ln	2.3	4.5	4.6	0.7	4.7	4.8	0.6	0.0	0.3	2.0	0.2	4.4
Unsig. Movement Delay, s/veh												
LnGrp Delay(d),s/veh	27.8	12.8	12.8	33.3	16.7	16.7	26.2	0.0	24.6	31.1	22.7	29.1
LnGrp LOS	C	B	B	C	B	B	C	A	C	C	C	C
Approach Vol, veh/h		1499			1034			76			761	
Approach Delay, s/veh		16.3			17.5			25.6			29.3	
Approach LOS		B			B			C			C	
Timer - Assigned Phs	1	2	3	4	5	6	7	8				
Phs Duration (G+Y+Rc), s	6.7	31.3	8.8	11.0	12.0	26.0	10.3	9.5				
Change Period (Y+Rc), s	4.0	4.0	4.0	4.0	4.0	4.0	4.0	4.0				
Max Green Setting (Gmax), s	5.5	44.0	6.5	7.0	10.0	40.5	8.0	5.5				
Max Q Clear Time (g_c+1), s	13.6	16.3	3.5	9.0	7.7	15.6	6.3	2.8				
Green Ext Time (p_c), s	0.0	8.2	0.0	0.0	0.3	6.5	0.1	0.0				
<b>Intersection Summary</b>												
HCM 6th Ctrl Delay				19.8								
HCM 6th LOS				B								

HCM 6th Signalized Intersection Summary  
 3: US 101 NB Off-Ramp & Shiloh Road

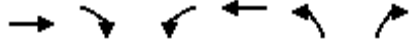

Movement	EBT	EBR	WBL	WBT	NBL	NBR
Lane Configurations	↑↑			↑↑	↘	↗↗
Traffic Volume (veh/h)	732	0	0	1103	813	601
Future Volume (veh/h)	732	0	0	1103	813	601
Initial Q (Qb), veh	0	0	0	0	0	0
Ped-Bike Adj(A_pbT)		1.00	1.00		1.00	1.00
Parking Bus, Adj	1.00	1.00	1.00	1.00	1.00	1.00
Work Zone On Approach	No			No	No	
Adj Sat Flow, veh/h/ln	1870	0	0	1870	1870	1870
Adj Flow Rate, veh/h	804	0	0	1226	1070	791
Peak Hour Factor	0.91	0.91	0.90	0.90	0.76	0.76
Percent Heavy Veh, %	2	0	0	2	2	2
Cap, veh/h	1199	0	0	1199	1002	1569
Arrive On Green	0.34	0.00	0.00	0.34	0.56	0.56
Sat Flow, veh/h	3741	0	0	3741	1781	2790
Grp Volume(v), veh/h	804	0	0	1226	1070	791
Grp Sat Flow(s),veh/h/ln1777		0	0	1777	1781	1395
Q Serve(g_s), s	15.5	0.0	0.0	27.0	45.0	13.9
Cycle Q Clear(g_c), s	15.5	0.0	0.0	27.0	45.0	13.9
Prop In Lane		0.00	0.00		1.00	1.00
Lane Grp Cap(c), veh/h	1199	0	0	1199	1002	1569
V/C Ratio(X)	0.67	0.00	0.00	1.02	1.07	0.50
Avail Cap(c_a), veh/h	1199	0	0	1199	1002	1569
HCM Platoon Ratio	1.00	1.00	1.00	1.00	1.00	1.00
Upstream Filter(I)	1.00	0.00	0.00	1.00	1.00	1.00
Uniform Delay (d), s/veh	22.7	0.0	0.0	26.5	17.5	10.7
Incr Delay (d2), s/veh	1.5	0.0	0.0	31.7	48.4	0.3
Initial Q Delay(d3),s/veh	0.0	0.0	0.0	0.0	0.0	0.0
%ile BackOfQ(50%),veh/ln6.1		0.0	0.0	15.6	29.1	3.8
Unsig. Movement Delay, s/veh						
LnGrp Delay(d),s/veh	24.1	0.0	0.0	58.2	65.9	10.9
LnGrp LOS	C	A	A	F	F	B
Approach Vol, veh/h	804			1226	1861	
Approach Delay, s/veh	24.1			58.2	42.5	
Approach LOS	C			E	D	
Timer - Assigned Phs		2			6	8
Phs Duration (G+Y+Rc), s		31.0			31.0	49.0
Change Period (Y+Rc), s		4.0			4.0	4.0
Max Green Setting (Gmax), s		27.0			27.0	45.0
Max Q Clear Time (g_c+I1), s		17.5			29.0	47.0
Green Ext Time (p_c), s		3.6			0.0	0.0

Intersection Summary

HCM 6th Ctrl Delay	43.7
HCM 6th LOS	D

Intersection						
Int Delay, s/veh	2.5					
Movement	EBT	EBR	WBL	WBT	NBL	NBR
Lane Configurations	↑↑		↘	↑↑	↘	↘
Traffic Vol, veh/h	900	14	130	1207	17	122
Future Vol, veh/h	900	14	130	1207	17	122
Conflicting Peds, #/hr	0	0	0	0	0	0
Sign Control	Free	Free	Free	Free	Stop	Stop
RT Channelized	-	None	-	None	-	None
Storage Length	-	-	68	-	0	0
Veh in Median Storage, #	0	-	-	0	0	-
Grade, %	0	-	-	0	0	-
Peak Hour Factor	96	96	87	87	84	84
Heavy Vehicles, %	2	2	2	2	2	2
Mvmt Flow	938	15	149	1387	20	145

Major/Minor	Major1	Major2	Minor1		
Conflicting Flow All	0	0	953	0	1938 477
Stage 1	-	-	-	-	946 -
Stage 2	-	-	-	-	992 -
Critical Hdwy	-	-	4.14	-	6.84 6.94
Critical Hdwy Stg 1	-	-	-	-	5.84 -
Critical Hdwy Stg 2	-	-	-	-	5.84 -
Follow-up Hdwy	-	-	2.22	-	3.52 3.32
Pot Cap-1 Maneuver	-	-	717	-	57 534
Stage 1	-	-	-	-	338 -
Stage 2	-	-	-	-	320 -
Platoon blocked, %	-	-	-	-	-
Mov Cap-1 Maneuver	-	-	717	-	45 534
Mov Cap-2 Maneuver	-	-	-	-	45 -
Stage 1	-	-	-	-	338 -
Stage 2	-	-	-	-	253 -

Approach	EB	WB	NB
HCM Control Delay, s	0	1.1	29.4
HCM LOS			D

Minor Lane/Major Mvmt	NBLn1	NBLn2	EBT	EBR	WBL	WBT
Capacity (veh/h)	45	534	-	-	717	-
HCM Lane V/C Ratio	0.45	0.272	-	-	0.208	-
HCM Control Delay (s)	138.7	14.2	-	-	11.3	-
HCM Lane LOS	F	B	-	-	B	-
HCM 95th %tile Q(veh)	1.6	1.1	-	-	0.8	-



HCM Signalized Intersection Capacity Analysis  
6: Conde Lane & Shiloh Road

GP 2040+Project Alternative A\_Mitigations  
Timing Plan: A.M. PEAK



Movement	EBL	EBT	EBR	WBL	WBT	WBR	NBL	NBT	NBR	SBL	SBT	SBR
Lane Configurations												
Traffic Volume (vph)	55	535	3	8	854	298	2	1	9	363	0	27
Future Volume (vph)	55	535	3	8	854	298	2	1	9	363	0	27
Ideal Flow (vphpl)	1900	1900	1900	1900	1900	1900	1900	1900	1900	1900	1900	1900
Total Lost time (s)	4.0	4.0		4.0	4.0			4.0			4.0	4.0
Lane Util. Factor	1.00	0.95		1.00	0.95			1.00			1.00	1.00
Frt	1.00	1.00		1.00	0.96			0.90			1.00	0.85
Flt Protected	0.95	1.00		0.95	1.00			0.99			0.95	1.00
Satd. Flow (prot)	1770	3536		1770	3402			1665			1770	1583
Flt Permitted	0.95	1.00		0.95	1.00			0.99			0.95	1.00
Satd. Flow (perm)	1770	3536		1770	3402			1665			1770	1583
Peak-hour factor, PHF	0.95	0.95	0.95	0.85	0.85	0.85	0.57	0.57	0.57	0.86	0.86	0.86
Adj. Flow (vph)	58	563	3	9	1005	351	4	2	16	422	0	31
RTOR Reduction (vph)	0	0	0	0	20	0	0	15	0	0	0	0
Lane Group Flow (vph)	58	566	0	9	1336	0	0	7	0	0	422	31
Turn Type	Prot	NA		Prot	NA		Split	NA		Split	NA	custom
Protected Phases	5	2		1	6		7	7		4	4	
Permitted Phases												6
Actuated Green, G (s)	6.2	59.6		1.5	54.9			3.6			31.3	54.9
Effective Green, g (s)	6.2	59.6		1.5	54.9			3.6			31.3	54.9
Actuated g/C Ratio	0.06	0.53		0.01	0.49			0.03			0.28	0.49
Clearance Time (s)	4.0	4.0		4.0	4.0			4.0			4.0	4.0
Vehicle Extension (s)	3.0	3.0		3.0	3.0			3.0			3.0	3.0
Lane Grp Cap (vph)	97	1881		23	1667			53			494	775
v/s Ratio Prot	c0.03	0.16		0.01	c0.39			c0.00			c0.24	
v/s Ratio Perm												0.02
v/c Ratio	0.60	0.30		0.39	0.80			0.12			0.85	0.04
Uniform Delay, d1	51.7	14.6		54.8	24.0			52.7			38.2	14.8
Progression Factor	1.00	1.00		1.00	1.00			1.00			1.00	1.00
Incremental Delay, d2	9.5	0.1		10.7	2.9			1.0			13.5	0.0
Delay (s)	61.2	14.7		65.5	26.8			53.7			51.7	14.9
Level of Service	E	B		E	C			D			D	B
Approach Delay (s)		19.0			27.1			53.7			49.1	
Approach LOS		B			C			D			D	

Intersection Summary		
HCM 2000 Control Delay	29.3	HCM 2000 Level of Service C
HCM 2000 Volume to Capacity ratio	0.78	
Actuated Cycle Length (s)	112.0	Sum of lost time (s) 16.0
Intersection Capacity Utilization	76.6%	ICU Level of Service D
Analysis Period (min)	15	

c Critical Lane Group

HCM 6th Signalized Intersection Summary  
8: Old Redwood Hwy & Driveway 2



Movement	EBL	EBT	EBR	WBL	WBT	WBR	NBL	NBT	NBR	SBL	SBT	SBR
Lane Configurations		↕		↗	↘			↕	↗	↘	↗	↘
Traffic Volume (veh/h)	1	0	0	19	0	31	0	662	28	45	914	0
Future Volume (veh/h)	1	0	0	19	0	31	0	662	28	45	914	0
Initial Q (Qb), veh	0	0	0	0	0	0	0	0	0	0	0	0
Ped-Bike Adj(A_pbT)	1.00		1.00	1.00		1.00	1.00		0.99	1.00		1.00
Parking Bus, Adj	1.00	1.00	1.00	1.00	1.00	1.00	1.00	1.00	1.00	1.00	1.00	1.00
Work Zone On Approach		No			No			No			No	
Adj Sat Flow, veh/h/ln	1870	1870	1870	1870	1870	1870	1870	1870	1870	1870	1870	1870
Adj Flow Rate, veh/h	4	0	0	19	0	31	0	669	28	50	1016	0
Peak Hour Factor	0.25	0.25	0.25	1.00	1.00	1.00	0.99	0.99	0.99	0.90	0.90	0.90
Percent Heavy Veh, %	2	2	2	2	2	2	2	2	2	2	2	2
Cap, veh/h	287	0	0	324	0	173	0	1226	1026	508	1226	0
Arrive On Green	0.11	0.00	0.00	0.11	0.00	0.11	0.00	0.66	0.66	0.66	0.66	0.00
Sat Flow, veh/h	1154	0	0	1418	0	1585	0	1870	1565	748	1870	0
Grp Volume(v), veh/h	4	0	0	19	0	31	0	669	28	50	1016	0
Grp Sat Flow(s),veh/h/ln	1154	0	0	1418	0	1585	0	1870	1565	748	1870	0
Q Serve(g_s), s	0.1	0.0	0.0	0.0	0.0	0.8	0.0	8.6	0.3	1.7	18.3	0.0
Cycle Q Clear(g_c), s	0.9	0.0	0.0	0.4	0.0	0.8	0.0	8.6	0.3	10.3	18.3	0.0
Prop In Lane	1.00		0.00	1.00		1.00	0.00		1.00	1.00		0.00
Lane Grp Cap(c), veh/h	287	0	0	324	0	173	0	1226	1026	508	1226	0
V/C Ratio(X)	0.01	0.00	0.00	0.06	0.00	0.18	0.00	0.55	0.03	0.10	0.83	0.00
Avail Cap(c_a), veh/h	692	0	0	740	0	639	0	1947	1629	796	1947	0
HCM Platoon Ratio	1.00	1.00	1.00	1.00	1.00	1.00	1.00	1.00	1.00	1.00	1.00	1.00
Upstream Filter(I)	1.00	0.00	0.00	1.00	0.00	1.00	0.00	1.00	1.00	1.00	1.00	0.00
Uniform Delay (d), s/veh	18.5	0.0	0.0	17.9	0.0	18.1	0.0	4.1	2.7	6.9	5.8	0.0
Incr Delay (d2), s/veh	0.0	0.0	0.0	0.1	0.0	0.5	0.0	0.4	0.0	0.1	1.7	0.0
Initial Q Delay(d3),s/veh	0.0	0.0	0.0	0.0	0.0	0.0	0.0	0.0	0.0	0.0	0.0	0.0
%ile BackOfQ(50%),veh/ln	0.0	0.0	0.0	0.2	0.0	0.3	0.0	0.9	0.0	0.2	2.2	0.0
Unsig. Movement Delay, s/veh												
LnGrp Delay(d),s/veh	18.5	0.0	0.0	18.0	0.0	18.6	0.0	4.5	2.7	7.0	7.5	0.0
LnGrp LOS	B	A	A	B	A	B	A	A	A	A	A	A
Approach Vol, veh/h		4			50			697			1066	
Approach Delay, s/veh		18.5			18.3			4.4			7.5	
Approach LOS		B			B			A			A	
Timer - Assigned Phs		2		4		6		8				
Phs Duration (G+Y+Rc), s		35.1		9.6		35.1		9.6				
Change Period (Y+Rc), s		5.8		* 4.7		5.8		* 4.7				
Max Green Setting (Gmax), s		46.5		* 18		46.5		* 18				
Max Q Clear Time (g_c+1), s		10.6		2.9		20.3		2.8				
Green Ext Time (p_c), s		4.7		0.0		9.0		0.1				

Intersection Summary

HCM 6th Ctrl Delay	6.7
HCM 6th LOS	A

Notes

\* HCM 6th computational engine requires equal clearance times for the phases crossing the barrier.

HCM 6th Signalized Intersection Summary

GP 2040+Project Alternative A\_Mitigations

12: US 101 SB On Ramp/US 101 SB Off Ramp & Old Redwood Highway

Timing Plan: A.M. PEAK



Movement	EBL	EBT	EBR	WBL	WBT	WBR	NBL	NBT	NBR	SBL	SBT	SBR
Lane Configurations		↑↑	↑	↑	↑↑					↑	↔	
Traffic Volume (veh/h)	0	699	814	559	742	0	0	0	0	185	0	144
Future Volume (veh/h)	0	699	814	559	742	0	0	0	0	185	0	144
Initial Q (Qb), veh	0	0	0	0	0	0				0	0	0
Ped-Bike Adj(A_pbT)	1.00		0.99	1.00		1.00				1.00		1.00
Parking Bus, Adj	1.00	1.00	1.00	1.00	1.00	1.00				1.00	1.00	1.00
Work Zone On Approach		No			No						No	
Adj Sat Flow, veh/h/ln	0	1870	1870	1870	1870	0				1870	1870	1870
Adj Flow Rate, veh/h	0	699	814	559	742	0				164	29	0
Peak Hour Factor	1.00	1.00	1.00	1.00	1.00	1.00				1.00	1.00	1.00
Percent Heavy Veh, %	0	2	2	2	2	0				2	2	2
Cap, veh/h	0	1588	698	600	2914	0				162	170	
Arrive On Green	0.00	0.45	0.45	0.34	0.82	0.00				0.09	0.09	0.00
Sat Flow, veh/h	0	3647	1561	1781	3647	0				1781	1870	0
Grp Volume(v), veh/h	0	699	814	559	742	0				164	29	0
Grp Sat Flow(s),veh/h/ln	0	1777	1561	1781	1777	0				1781	1870	0
Q Serve(g_s), s	0.0	14.9	49.2	33.4	5.2	0.0				10.0	1.6	0.0
Cycle Q Clear(g_c), s	0.0	14.9	49.2	33.4	5.2	0.0				10.0	1.6	0.0
Prop In Lane	0.00		1.00	1.00		0.00				1.00		0.00
Lane Grp Cap(c), veh/h	0	1588	698	600	2914	0				162	170	
V/C Ratio(X)	0.00	0.44	1.17	0.93	0.25	0.00				1.01	0.17	
Avail Cap(c_a), veh/h	0	1588	698	823	2914	0				162	170	
HCM Platoon Ratio	1.00	1.00	1.00	1.00	1.00	1.00				1.00	1.00	1.00
Upstream Filter(I)	0.00	1.00	1.00	1.00	1.00	0.00				1.00	1.00	0.00
Uniform Delay (d), s/veh	0.0	20.9	30.4	35.3	2.3	0.0				50.0	46.2	0.0
Incr Delay (d2), s/veh	0.0	0.9	90.1	14.0	0.2	0.0				74.1	0.5	0.0
Initial Q Delay(d3),s/veh	0.0	0.0	0.0	0.0	0.0	0.0				0.0	0.0	0.0
%ile BackOfQ(50%),veh/ln	0.0	6.2	34.9	16.3	1.2	0.0				7.8	0.8	0.0
Unsig. Movement Delay, s/veh												
LnGrp Delay(d),s/veh	0.0	21.8	120.5	49.3	2.5	0.0				124.1	46.6	0.0
LnGrp LOS		A	C	F	D	A				F	D	
Approach Vol, veh/h		1513			1301					193		
Approach Delay, s/veh		74.9			22.6					112.5		
Approach LOS		E			C					F		
Timer - Assigned Phs		2			5		6		8			
Phs Duration (G+Y+Rc), s		95.3			41.0		54.3		14.7			
Change Period (Y+Rc), s		5.1			4.0		5.1		4.7			
Max Green Setting (Gmax), s		90.2			50.8		35.4		10.0			
Max Q Clear Time (g_c+11), s		7.2			35.4		51.2		12.0			
Green Ext Time (p_c), s		6.0			1.7		0.0		0.0			

Intersection Summary

























HCM 6th Ctrl Delay	54.7
HCM 6th LOS	D

Notes

- User approved volume balancing among the lanes for turning movement.
- User approved ignoring U-Turning movement.
- Unsignalized Delay for [SBR] is excluded from calculations of the approach delay and intersection delay.

HCM 6th Signalized Intersection Summary  
 1: Old Redwood Hwy & Shiloh Road

GP 2040+Project Alternative A\_Mitigations  
 Timing Plan: P.M. Peak

												
Movement	EBL	EBT	EBR	WBL	WBT	WBR	NBL	NBT	NBR	SBL	SBT	SBR
Lane Configurations												
Traffic Volume (veh/h)	317	558	672	44	442	70	667	567	44	100	550	265
Future Volume (veh/h)	317	558	672	44	442	70	667	567	44	100	550	265
Initial Q (Qb), veh	0	0	0	0	0	0	0	0	0	0	0	0
Ped-Bike Adj(A_pbT)	1.00		1.00	1.00		1.00	1.00		0.98	1.00		0.98
Parking Bus, Adj	1.00	1.00	1.00	1.00	1.00	1.00	1.00	1.00	1.00	1.00	1.00	1.00
Work Zone On Approach		No			No			No			No	
Adj Sat Flow, veh/h/ln	1870	1870	1870	1870	1870	1870	1870	1870	1870	1870	1870	1870
Adj Flow Rate, veh/h	317	558	672	44	442	70	667	567	44	100	550	265
Peak Hour Factor	1.00	1.00	1.00	1.00	1.00	1.00	1.00	1.00	1.00	1.00	1.00	1.00
Percent Heavy Veh, %	2	2	2	2	2	2	2	2	2	2	2	2
Cap, veh/h	355	1250	557	84	708	315	769	1304	568	134	780	342
Arrive On Green	0.20	0.35	0.35	0.05	0.20	0.20	0.22	0.37	0.37	0.07	0.22	0.22
Sat Flow, veh/h	1781	3554	1583	1781	3554	1583	3456	3554	1546	1781	3554	1559
Grp Volume(v), veh/h	317	558	672	44	442	70	667	567	44	100	550	265
Grp Sat Flow(s),veh/h/ln	1781	1777	1583	1781	1777	1583	1728	1777	1546	1781	1777	1559
Q Serve(g_s), s	18.5	12.9	37.5	2.6	12.1	4.0	19.8	12.8	2.0	5.9	15.2	17.0
Cycle Q Clear(g_c), s	18.5	12.9	37.5	2.6	12.1	4.0	19.8	12.8	2.0	5.9	15.2	17.0
Prop In Lane	1.00		1.00	1.00		1.00	1.00		1.00	1.00		1.00
Lane Grp Cap(c), veh/h	355	1250	557	84	708	315	769	1304	568	134	780	342
V/C Ratio(X)	0.89	0.45	1.21	0.53	0.62	0.22	0.87	0.43	0.08	0.75	0.71	0.77
Avail Cap(c_a), veh/h	571	1250	557	635	1377	613	1053	1700	740	276	1167	512
HCM Platoon Ratio	1.00	1.00	1.00	1.00	1.00	1.00	1.00	1.00	1.00	1.00	1.00	1.00
Upstream Filter(I)	1.00	1.00	1.00	1.00	1.00	1.00	1.00	1.00	1.00	1.00	1.00	1.00
Uniform Delay (d), s/veh	41.6	26.6	34.6	49.7	39.0	35.8	39.9	25.4	22.0	48.3	38.4	39.1
Incr Delay (d2), s/veh	10.5	0.3	109.3	5.1	0.9	0.4	5.9	0.2	0.1	8.1	1.2	4.2
Initial Q Delay(d3),s/veh	0.0	0.0	0.0	0.0	0.0	0.0	0.0	0.0	0.0	0.0	0.0	0.0
%ile BackOfQ(50%),veh/ln	8.9	5.3	30.3	1.2	5.2	1.5	8.7	5.2	0.7	2.8	6.6	6.6
Unsig. Movement Delay, s/veh												
LnGrp Delay(d),s/veh	52.0	26.8	143.8	54.7	39.9	36.1	45.8	25.6	22.0	56.4	39.6	43.4
LnGrp LOS	D	C	F	D	D	D	D	C	C	E	D	D
Approach Vol, veh/h		1547			556			1278			915	
Approach Delay, s/veh		82.8			40.6			36.1			42.5	
Approach LOS		F			D			D			D	
Timer - Assigned Phs	1	2	3	4	5	6	7	8				
Phs Duration (G+Y+Rc), s	9.5	42.0	27.2	27.9	25.8	25.7	11.5	43.6				
Change Period (Y+Rc), s	4.5	4.5	3.5	4.5	4.5	4.5	3.5	4.5				
Max Green Setting (Gmax), s	38.0	37.5	32.5	35.0	34.2	41.3	16.5	51.0				
Max Q Clear Time (g_c+I1), s	4.6	39.5	21.8	19.0	20.5	14.1	7.9	14.8				
Green Ext Time (p_c), s	0.1	0.0	1.9	4.0	0.8	3.1	0.1	3.9				
<b>Intersection Summary</b>												
HCM 6th Ctrl Delay			54.9									
HCM 6th LOS			D									

HCM 6th Signalized Intersection Summary  
2: Shiloh Road & Hembree Ln



Movement	EBL	EBT	EBR	WBL	WBT	WBR	NBL	NBT	NBR	SBL	SBT	SBR
Lane Configurations	↖ ↗	↑		↖ ↗	↑		↖ ↗	↑		↖ ↗	↑	↖ ↗
Traffic Volume (veh/h)	661	1344	69	110	1146	118	111	21	128	174	11	526
Future Volume (veh/h)	661	1344	69	110	1146	118	111	21	128	174	11	526
Initial Q (Qb), veh	0	0	0	0	0	0	0	0	0	0	0	0
Ped-Bike Adj(A_pbT)	1.00		1.00	1.00		1.00	1.00		1.00	1.00		1.00
Parking Bus, Adj	1.00	1.00	1.00	1.00	1.00	1.00	1.00	1.00	1.00	1.00	1.00	1.00
Work Zone On Approach		No		No		No		No		No		No
Adj Sat Flow, veh/h/ln	1870	1870	1870	1870	1870	1870	1870	1870	1870	1870	1870	1870
Adj Flow Rate, veh/h	703	1430	69	110	1317	136	111	21	128	183	11	554
Peak Hour Factor	0.94	0.94	1.00	1.00	0.87	0.87	1.00	1.00	1.00	0.95	1.00	0.95
Percent Heavy Veh, %	2	2	2	2	2	2	2	2	2	2	2	2
Cap, veh/h	718	1961	94	139	1426	147	140	14	86	200	179	846
Arrive On Green	0.21	0.57	0.57	0.08	0.44	0.44	0.08	0.06	0.06	0.11	0.10	0.10
Sat Flow, veh/h	3456	3451	166	1781	3252	334	1781	228	1392	1781	1870	2790
Grp Volume(v), veh/h	703	735	764	110	717	736	111	0	149	183	11	554
Grp Sat Flow(s),veh/h/ln	1728	1777	1840	1781	1777	1810	1781	0	1620	1781	1870	1395
Q Serve(g_s), s	18.0	27.1	27.3	5.4	33.8	34.3	5.5	0.0	5.5	9.0	0.5	8.5
Cycle Q Clear(g_c), s	18.0	27.1	27.3	5.4	33.8	34.3	5.5	0.0	5.5	9.0	0.5	8.5
Prop In Lane	1.00		0.09	1.00		0.18	1.00		0.86	1.00		1.00
Lane Grp Cap(c), veh/h	718	1010	1046	139	779	793	140	0	100	200	179	846
V/C Ratio(X)	0.98	0.73	0.73	0.79	0.92	0.93	0.79	0.00	1.49	0.91	0.06	0.65
Avail Cap(c_a), veh/h	718	1010	1046	180	798	813	174	0	100	200	179	846
HCM Platoon Ratio	1.00	1.00	1.00	1.00	1.00	1.00	1.00	1.00	1.00	1.00	1.00	1.00
Upstream Filter(I)	1.00	1.00	1.00	1.00	1.00	1.00	1.00	0.00	1.00	1.00	1.00	1.00
Uniform Delay (d), s/veh	35.1	14.2	14.2	40.3	23.5	23.7	40.3	0.0	41.8	39.1	36.6	27.0
Incr Delay (d2), s/veh	28.3	2.7	2.6	16.3	15.6	16.5	17.8	0.0	265.4	40.6	0.1	1.8
Initial Q Delay(d3),s/veh	0.0	0.0	0.0	0.0	0.0	0.0	0.0	0.0	0.0	0.0	0.0	0.0
%ile BackOfQ(50%),veh/ln	0.0	9.9	10.4	2.9	16.1	16.7	3.0	0.0	9.5	6.1	0.2	5.2
Unsig. Movement Delay, s/veh												
LnGrp Delay(d),s/veh	63.4	16.8	16.8	56.7	39.2	40.1	58.1	0.0	307.2	79.7	36.8	28.8
LnGrp LOS	E	B	B	E	D	D	E	A	F	E	D	C
Approach Vol, veh/h		2202			1563			260			748	
Approach Delay, s/veh		31.7			40.9			200.8			41.4	
Approach LOS		C			D			F			D	
Timer - Assigned Phs	1	2	3	4	5	6	7	8				
Phs Duration (G+Y+Rc), s	10.9	54.6	11.0	12.5	22.5	43.0	14.0	9.5				
Change Period (Y+Rc), s	4.0	4.0	4.0	4.0	4.0	4.0	4.0	4.0				
Max Green Setting (Gmax), s	49.5	49.5	8.7	6.8	18.5	40.0	10.0	5.5				
Max Q Clear Time (g_c+1), s	29.3	29.3	7.5	10.5	20.0	36.3	11.0	7.5				
Green Ext Time (p_c), s	0.0	10.4	0.0	0.0	0.0	2.7	0.0	0.0				

Intersection Summary

HCM 6th Ctrl Delay	45.4
HCM 6th LOS	D

HCM 6th Signalized Intersection Summary  
 3: US 101 NB Off-Ramp & Shiloh Road

GP 2040+Project Alternative A\_Mitigations  
 Timing Plan: P.M. Peak

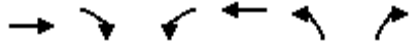

Movement	EBT	EBR	WBL	WBT	NBL	NBR
Lane Configurations	↑↑			↑↑	↘	↗↗
Traffic Volume (veh/h)	974	0	0	1119	694	1057
Future Volume (veh/h)	974	0	0	1119	694	1057
Initial Q (Qb), veh	0	0	0	0	0	0
Ped-Bike Adj(A_pbT)		1.00	1.00		1.00	1.00
Parking Bus, Adj	1.00	1.00	1.00	1.00	1.00	1.00
Work Zone On Approach	No			No	No	
Adj Sat Flow, veh/h/ln	1870	0	0	1870	1870	1870
Adj Flow Rate, veh/h	1036	0	0	1154	771	1174
Peak Hour Factor	0.94	0.94	0.97	0.97	0.90	0.90
Percent Heavy Veh, %	2	0	0	2	2	2
Cap, veh/h	1340	0	0	1340	862	1349
Arrive On Green	0.38	0.00	0.00	0.38	0.48	0.48
Sat Flow, veh/h	3741	0	0	3741	1781	2790
Grp Volume(v), veh/h	1036	0	0	1154	771	1174
Grp Sat Flow(s),veh/h/ln	1777	0	0	1777	1781	1395
Q Serve(g_s), s	14.7	0.0	0.0	17.2	22.6	21.5
Cycle Q Clear(g_c), s	14.7	0.0	0.0	17.2	22.6	21.5
Prop In Lane		0.00	0.00		1.00	1.00
Lane Grp Cap(c), veh/h	1340	0	0	1340	862	1349
V/C Ratio(X)	0.77	0.00	0.00	0.86	0.89	0.87
Avail Cap(c_a), veh/h	1423	0	0	1423	900	1409
HCM Platoon Ratio	1.00	1.00	1.00	1.00	1.00	1.00
Upstream Filter(I)	1.00	0.00	0.00	1.00	1.00	1.00
Uniform Delay (d), s/veh	15.7	0.0	0.0	16.5	13.5	13.2
Incr Delay (d2), s/veh	2.6	0.0	0.0	5.4	11.2	6.0
Initial Q Delay(d3),s/veh	0.0	0.0	0.0	0.0	0.0	0.0
%ile BackOfQ(50%),veh/ln	5.3	0.0	0.0	6.6	10.0	6.6
Unsig. Movement Delay, s/veh						
LnGrp Delay(d),s/veh	18.3	0.0	0.0	21.9	24.7	19.2
LnGrp LOS	B	A	A	C	C	B
Approach Vol, veh/h	1036			1154	1945	
Approach Delay, s/veh	18.3			21.9	21.4	
Approach LOS	B			C	C	
Timer - Assigned Phs		2			6	8
Phs Duration (G+Y+Rc), s		25.6			25.6	31.8
Change Period (Y+Rc), s		4.0			4.0	4.0
Max Green Setting (Gmax), s		23.0			23.0	29.0
Max Q Clear Time (g_c+I1), s		16.7			19.2	24.6
Green Ext Time (p_c), s		3.4			2.4	3.1
<b>Intersection Summary</b>						
HCM 6th Ctrl Delay			20.7			
HCM 6th LOS			C			

Intersection						
Int Delay, s/veh	2.6					
Movement	EBT	EBR	WBL	WBT	NBL	NBR
Lane Configurations	↑↑		↘	↑↑	↘	↘
Traffic Vol, veh/h	1214	16	105	1143	18	159
Future Vol, veh/h	1214	16	105	1143	18	159
Conflicting Peds, #/hr	0	0	0	0	0	0
Sign Control	Free	Free	Free	Free	Stop	Stop
RT Channelized	-	None	-	None	-	None
Storage Length	-	-	68	-	0	0
Veh in Median Storage, #	0	-	-	0	0	-
Grade, %	0	-	-	0	0	-
Peak Hour Factor	100	100	100	100	100	100
Heavy Vehicles, %	2	2	2	2	2	2
Mvmt Flow	1214	16	105	1143	18	159



















Major/Minor	Major1	Major2	Minor1		
Conflicting Flow All	0	0	1230	0	2004
Stage 1	-	-	-	-	1222
Stage 2	-	-	-	-	782
Critical Hdwy	-	-	4.14	-	6.84
Critical Hdwy Stg 1	-	-	-	-	5.84
Critical Hdwy Stg 2	-	-	-	-	5.84
Follow-up Hdwy	-	-	2.22	-	3.52
Pot Cap-1 Maneuver	-	-	562	-	52
Stage 1	-	-	-	-	241
Stage 2	-	-	-	-	411
Platoon blocked, %	-	-	-	-	-
Mov Cap-1 Maneuver	-	-	562	-	42
Mov Cap-2 Maneuver	-	-	-	-	42
Stage 1	-	-	-	-	241
Stage 2	-	-	-	-	334

Approach	EB	WB	NB
HCM Control Delay, s	0	1.1	30.8
HCM LOS			D

Minor Lane/Major Mvmt	NBLn1	NBLn2	EBT	EBR	WBL	WBT
Capacity (veh/h)	42	434	-	-	562	-
HCM Lane V/C Ratio	0.429	0.366	-	-	0.187	-
HCM Control Delay (s)	144	18	-	-	12.9	-
HCM Lane LOS	F	C	-	-	B	-
HCM 95th %tile Q(veh)	1.5	1.7	-	-	0.7	-

HCM Signalized Intersection Capacity Analysis  
6: Conde Lane & Shiloh Road

GP 2040+Project Alternative A\_Mitigations  
Timing Plan: P.M. Peak

												
Movement	EBL	EBT	EBR	WBL	WBT	WBR	NBL	NBT	NBR	SBL	SBT	SBR
Lane Configurations												
Traffic Volume (vph)	77	737	0	9	747	372	4	2	16	387	4	65
Future Volume (vph)	77	737	0	9	747	372	4	2	16	387	4	65
Ideal Flow (vphpl)	1900	1900	1900	1900	1900	1900	1900	1900	1900	1900	1900	1900
Total Lost time (s)	4.0	4.0		4.0	4.0			4.0			4.0	4.0
Lane Util. Factor	1.00	0.95		1.00	0.95			1.00			1.00	1.00
Frbp, ped/bikes	1.00	1.00		1.00	0.99			1.00			1.00	1.00
Flpb, ped/bikes	1.00	1.00		1.00	1.00			1.00			1.00	1.00
Frt	1.00	1.00		1.00	0.95			0.90			1.00	0.85
Flt Protected	0.95	1.00		0.95	1.00			0.99			0.95	1.00
Satd. Flow (prot)	1770	3539		1770	3339			1663			1775	1583
Flt Permitted	0.95	1.00		0.95	1.00			0.99			0.95	1.00
Satd. Flow (perm)	1770	3539		1770	3339			1663			1775	1583
Peak-hour factor, PHF	0.88	0.88	0.88	0.80	0.80	0.80	0.63	0.63	0.63	0.88	0.88	0.88
Adj. Flow (vph)	88	838	0	11	934	465	6	3	25	440	5	74
RTOR Reduction (vph)	0	0	0	0	34	0	0	24	0	0	0	0
Lane Group Flow (vph)	88	838	0	11	1365	0	0	10	0	0	445	74
Confl. Peds. (#/hr)	1					1						
Turn Type	Prot	NA		Prot	NA		Split	NA		Split	NA	custom
Protected Phases	5	2		1	6		7	7		4	4	
Permitted Phases												6
Actuated Green, G (s)	8.0	66.9		1.5	60.4			5.7			36.1	60.4
Effective Green, g (s)	8.0	66.9		1.5	60.4			5.7			36.1	60.4
Actuated g/C Ratio	0.06	0.53		0.01	0.48			0.05			0.29	0.48
Clearance Time (s)	4.0	4.0		4.0	4.0			4.0			4.0	4.0
Vehicle Extension (s)	3.0	3.0		3.0	3.0			3.0			3.0	3.0
Lane Grp Cap (vph)	112	1876		21	1598			75			507	757
v/s Ratio Prot	c0.05	0.24		0.01	c0.41			c0.01			c0.25	
v/s Ratio Perm												0.05
v/c Ratio	0.79	0.45		0.52	0.85			0.14			0.88	0.10
Uniform Delay, d1	58.3	18.3		62.0	29.0			57.9			42.9	18.0
Progression Factor	1.00	1.00		1.00	1.00			1.00			1.00	1.00
Incremental Delay, d2	29.4	0.2		21.6	4.7			0.8			15.7	0.1
Delay (s)	87.7	18.4		83.6	33.7			58.7			58.6	18.1
Level of Service	F	B		F	C			E			E	B
Approach Delay (s)		25.0			34.1			58.7			52.9	
Approach LOS		C			C			E			D	
<b>Intersection Summary</b>												
HCM 2000 Control Delay			34.8			HCM 2000 Level of Service			C			
HCM 2000 Volume to Capacity ratio			0.82									
Actuated Cycle Length (s)			126.2			Sum of lost time (s)		16.0				
Intersection Capacity Utilization			77.6%			ICU Level of Service			D			
Analysis Period (min)			15									
c	Critical Lane Group											



HCM 6th Signalized Intersection Summary  
7: Driveway 1/Gridley Drive & Shiloh Road

GP 2040+Project Alternative A\_Mitigations  
Timing Plan: P.M. Peak



Movement	EBL	EBT	EBR	WBL	WBT	WBR	NBL	NBT	NBR	SBL	SBT	SBR
Lane Configurations		↕	↕		↕		↕	↕			↕	
Traffic Volume (veh/h)	25	521	121	0	443	0	84	0	0	0	0	21
Future Volume (veh/h)	25	521	121	0	443	0	84	0	0	0	0	21
Initial Q (Qb), veh	0	0	0	0	0	0	0	0	0	0	0	0
Ped-Bike Adj(A_pbT)	1.00		0.99	1.00		1.00	1.00		1.00	1.00		1.00
Parking Bus, Adj	1.00	1.00	1.00	1.00	1.00	1.00	1.00	1.00	1.00	1.00	1.00	1.00
Work Zone On Approach		No		No		No		No		No		No
Adj Sat Flow, veh/h/ln	1870	1870	1870	1870	1870	1870	1870	1870	1870	1870	1870	1870
Adj Flow Rate, veh/h	27	554	129	0	642	0	84	0	0	0	0	36
Peak Hour Factor	0.94	0.94	0.94	0.69	0.69	0.69	1.00	1.00	1.00	0.58	0.58	0.58
Percent Heavy Veh, %	2	2	2	2	2	2	2	2	2	2	2	2
Cap, veh/h	116	767	705	0	843	0	549	511	0	0	0	433
Arrive On Green	0.45	0.45	0.45	0.00	0.45	0.00	0.27	0.00	0.00	0.00	0.00	0.27
Sat Flow, veh/h	30	1701	1564	0	1870	0	1372	1870	0	0	0	1585
Grp Volume(v), veh/h	581	0	129	0	642	0	84	0	0	0	0	36
Grp Sat Flow(s),veh/h/ln	1731	0	1564	0	1870	0	1372	1870	0	0	0	1585
Q Serve(g_s), s	0.4	0.0	1.8	0.0	10.5	0.0	1.8	0.0	0.0	0.0	0.0	0.6
Cycle Q Clear(g_c), s	10.9	0.0	1.8	0.0	10.5	0.0	2.4	0.0	0.0	0.0	0.0	0.6
Prop In Lane	0.05		1.00	0.00		0.00	1.00		0.00	0.00		1.00
Lane Grp Cap(c), veh/h	883	0	705	0	843	0	549	511	0	0	0	433
V/C Ratio(X)	0.66	0.00	0.18	0.00	0.76	0.00	0.15	0.00	0.00	0.00	0.00	0.08
Avail Cap(c_a), veh/h	1378	0	1146	0	1370	0	1040	1181	0	0	0	1001
HCM Platoon Ratio	1.00	1.00	1.00	1.00	1.00	1.00	1.00	1.00	1.00	1.00	1.00	1.00
Upstream Filter(I)	1.00	0.00	1.00	0.00	1.00	0.00	1.00	0.00	0.00	0.00	0.00	1.00
Uniform Delay (d), s/veh	8.0	0.0	6.0	0.0	8.4	0.0	10.8	0.0	0.0	0.0	0.0	9.9
Incr Delay (d2), s/veh	0.8	0.0	0.1	0.0	1.5	0.0	0.1	0.0	0.0	0.0	0.0	0.1
Initial Q Delay(d3),s/veh	0.0	0.0	0.0	0.0	0.0	0.0	0.0	0.0	0.0	0.0	0.0	0.0
%ile BackOfQ(50%),veh/ln	2.1	0.0	0.3	0.0	2.5	0.0	0.4	0.0	0.0	0.0	0.0	0.2
Unsig. Movement Delay, s/veh												
LnGrp Delay(d),s/veh	8.9	0.0	6.1	0.0	9.9	0.0	10.9	0.0	0.0	0.0	0.0	10.0
LnGrp LOS	A	A	A	A	A	A	B	A	A	A	A	A
Approach Vol, veh/h		710			642			84				36
Approach Delay, s/veh		8.4			9.9			10.9				10.0
Approach LOS		A			A			B				A
Timer - Assigned Phs		2		4		6		8				
Phs Duration (G+Y+Rc), s		14.7		21.9		14.7		21.9				
Change Period (Y+Rc), s		* 4.7		5.4		* 4.7		5.4				
Max Green Setting (Gmax), s		* 23		26.8		* 23		26.8				
Max Q Clear Time (g_c+I1), s		4.4		12.9		2.6		12.5				
Green Ext Time (p_c), s		0.2		3.5		0.1		3.5				

Intersection Summary

HCM 6th Ctrl Delay	9.2
HCM 6th LOS	A

Notes

\* HCM 6th computational engine requires equal clearance times for the phases crossing the barrier.

HCM 6th Signalized Intersection Summary  
8: Old Redwood Hwy & Driveway 2

GP 2040+Project Alternative A\_Mitigations  
Timing Plan: P.M. Peak



Movement	EBL	EBT	EBR	WBL	WBT	WBR	NBL	NBT	NBR	SBL	SBT	SBR
Lane Configurations		↕		↗	↘			↖	↗	↘	↖	↘
Traffic Volume (veh/h)	4	0	0	49	0	79	0	1195	71	114	1152	0
Future Volume (veh/h)	4	0	0	49	0	79	0	1195	71	114	1152	0
Initial Q (Qb), veh	0	0	0	0	0	0	0	0	0	0	0	0
Ped-Bike Adj(A_pbT)	1.00		1.00	1.00		1.00	1.00		0.99	1.00		1.00
Parking Bus, Adj	1.00	1.00	1.00	1.00	1.00	1.00	1.00	1.00	1.00	1.00	1.00	1.00
Work Zone On Approach		No			No			No			No	
Adj Sat Flow, veh/h/ln	1870	1870	1870	1870	1870	1870	1870	1870	1870	1870	1870	1870
Adj Flow Rate, veh/h	11	0	0	49	0	79	0	1313	78	121	1226	0
Peak Hour Factor	0.38	0.38	0.38	1.00	1.00	1.00	0.91	0.91	0.91	0.94	0.94	0.94
Percent Heavy Veh, %	2	2	2	2	2	2	2	2	2	2	2	2
Cap, veh/h	109	0	0	201	0	134	0	1545	1293	223	1545	0
Arrive On Green	0.08	0.00	0.00	0.08	0.00	0.08	0.00	0.83	0.83	0.83	0.83	0.00
Sat Flow, veh/h	568	0	0	1418	0	1585	0	1870	1565	389	1870	0
Grp Volume(v), veh/h	11	0	0	49	0	79	0	1313	78	121	1226	0
Grp Sat Flow(s),veh/h/ln	568	0	0	1418	0	1585	0	1870	1565	389	1870	0
Q Serve(g_s), s	1.0	0.0	0.0	0.0	0.0	5.6	0.0	48.0	1.1	31.0	38.8	0.0
Cycle Q Clear(g_c), s	6.6	0.0	0.0	3.0	0.0	5.6	0.0	48.0	1.1	79.0	38.8	0.0
Prop In Lane	1.00		0.00	1.00		1.00	0.00		1.00	1.00		0.00
Lane Grp Cap(c), veh/h	109	0	0	201	0	134	0	1545	1293	223	1545	0
V/C Ratio(X)	0.10	0.00	0.00	0.24	0.00	0.59	0.00	0.85	0.06	0.54	0.79	0.00
Avail Cap(c_a), veh/h	200	0	0	299	0	243	0	1777	1487	271	1777	0
HCM Platoon Ratio	1.00	1.00	1.00	1.00	1.00	1.00	1.00	1.00	1.00	1.00	1.00	1.00
Upstream Filter(I)	1.00	0.00	0.00	1.00	0.00	1.00	0.00	1.00	1.00	1.00	1.00	0.00
Uniform Delay (d), s/veh	55.0	0.0	0.0	50.6	0.0	51.8	0.0	5.9	1.9	29.0	5.1	0.0
Incr Delay (d2), s/veh	0.4	0.0	0.0	0.6	0.0	4.1	0.0	3.7	0.0	2.0	2.2	0.0
Initial Q Delay(d3),s/veh	0.0	0.0	0.0	0.0	0.0	0.0	0.0	0.0	0.0	0.0	0.0	0.0
%ile BackOfQ(50%),veh/ln	0.3	0.0	0.0	1.4	0.0	2.4	0.0	10.8	0.2	2.8	8.4	0.0
Unsig. Movement Delay, s/veh												
LnGrp Delay(d),s/veh	55.4	0.0	0.0	51.2	0.0	55.9	0.0	9.6	1.9	31.0	7.4	0.0
LnGrp LOS	E	A	A	D	A	E	A	A	A	C	A	A
Approach Vol, veh/h		11			128			1391			1347	
Approach Delay, s/veh		55.4			54.1			9.2			9.5	
Approach LOS		E			D			A			A	
Timer - Assigned Phs		2		4		6		8				
Phs Duration (G+Y+Rc), s		102.8		14.6		102.8		14.6				
Change Period (Y+Rc), s		5.8		* 4.7		5.8		* 4.7				
Max Green Setting (Gmax), s		111.5		* 18		111.5		* 18				
Max Q Clear Time (g_c+1), s		50.0		8.6		81.0		7.6				
Green Ext Time (p_c), s		20.6		0.0		16.0		0.3				

Intersection Summary

























HCM 6th Ctrl Delay	11.5
HCM 6th LOS	B

Notes

\* HCM 6th computational engine requires equal clearance times for the phases crossing the barrier.

HCM 6th Signalized Intersection Summary  
 1: Old Redwood Hwy & Shiloh Road

GP 2040+Project Alternative A\_Mitigations  
 Timing Plan: Saturday Midday Peak

												
Movement	EBL	EBT	EBR	WBL	WBT	WBR	NBL	NBT	NBR	SBL	SBT	SBR
Lane Configurations												
Traffic Volume (veh/h)	182	506	308	31	522	76	317	352	35	83	285	266
Future Volume (veh/h)	182	506	308	31	522	76	317	352	35	83	285	266
Initial Q (Qb), veh	0	0	0	0	0	0	0	0	0	0	0	0
Ped-Bike Adj(A_pbT)	1.00		0.97	1.00		1.00	1.00		0.98	1.00		0.98
Parking Bus, Adj	1.00	1.00	1.00	1.00	1.00	1.00	1.00	1.00	1.00	1.00	1.00	1.00
Work Zone On Approach		No			No			No			No	
Adj Sat Flow, veh/h/ln	1870	1870	1870	1870	1870	1870	1870	1870	1870	1870	1870	1870
Adj Flow Rate, veh/h	204	569	346	36	607	88	341	378	38	91	313	292
Peak Hour Factor	0.89	0.89	0.89	0.86	0.86	0.86	0.93	0.93	0.93	0.91	0.91	0.91
Percent Heavy Veh, %	2	2	2	2	2	2	2	2	2	2	2	2
Cap, veh/h	257	1164	505	120	890	397	447	1039	454	137	853	374
Arrive On Green	0.14	0.33	0.33	0.07	0.25	0.25	0.13	0.29	0.29	0.08	0.24	0.24
Sat Flow, veh/h	1781	3554	1542	1781	3554	1585	3456	3554	1551	1781	3554	1559
Grp Volume(v), veh/h	204	569	346	36	607	88	341	378	38	91	313	292
Grp Sat Flow(s),veh/h/ln	1781	1777	1542	1781	1777	1585	1728	1777	1551	1781	1777	1559
Q Serve(g_s), s	8.2	9.5	14.4	1.4	11.5	3.3	7.1	6.3	1.3	3.7	5.5	13.0
Cycle Q Clear(g_c), s	8.2	9.5	14.4	1.4	11.5	3.3	7.1	6.3	1.3	3.7	5.5	13.0
Prop In Lane	1.00		1.00	1.00		1.00	1.00		1.00	1.00		1.00
Lane Grp Cap(c), veh/h	257	1164	505	120	890	397	447	1039	454	137	853	374
V/C Ratio(X)	0.79	0.49	0.68	0.30	0.68	0.22	0.76	0.36	0.08	0.66	0.37	0.78
Avail Cap(c_a), veh/h	720	1459	633	911	1842	822	651	2010	877	168	1675	735
HCM Platoon Ratio	1.00	1.00	1.00	1.00	1.00	1.00	1.00	1.00	1.00	1.00	1.00	1.00
Upstream Filter(I)	1.00	1.00	1.00	1.00	1.00	1.00	1.00	1.00	1.00	1.00	1.00	1.00
Uniform Delay (d), s/veh	30.7	20.0	21.6	33.0	25.2	22.1	31.2	20.8	19.1	33.3	23.5	26.4
Incr Delay (d2), s/veh	5.5	0.3	2.2	1.4	0.9	0.3	3.2	0.2	0.1	7.0	0.3	3.6
Initial Q Delay(d3),s/veh	0.0	0.0	0.0	0.0	0.0	0.0	0.0	0.0	0.0	0.0	0.0	0.0
%ile BackOfQ(50%),veh/ln	3.7	3.6	4.9	0.6	4.6	1.1	2.9	2.4	0.4	1.8	2.1	4.7
Unsig. Movement Delay, s/veh												
LnGrp Delay(d),s/veh	36.2	20.3	23.8	34.4	26.1	22.4	34.4	21.0	19.1	40.3	23.8	30.0
LnGrp LOS	D	C	C	C	C	C	C	C	B	D	C	C
Approach Vol, veh/h		1119			731			757			696	
Approach Delay, s/veh		24.3			26.0			27.0			28.5	
Approach LOS		C			C			C			C	
Timer - Assigned Phs	1	2	3	4	5	6	7	8				
Phs Duration (G+Y+Rc), s	9.5	28.8	13.6	22.3	15.2	23.1	9.7	26.2				
Change Period (Y+Rc), s	4.5	4.5	4.0	4.5	4.5	4.5	4.0	4.5				
Max Green Setting (Gmax), s	38.0	30.5	14.0	35.0	30.0	38.5	7.0	42.0				
Max Q Clear Time (g_c+I1), s	3.4	16.4	9.1	15.0	10.2	13.5	5.7	8.3				
Green Ext Time (p_c), s	0.1	4.2	0.5	2.8	0.5	4.3	0.0	2.5				
<b>Intersection Summary</b>												
HCM 6th Ctrl Delay				26.2								
HCM 6th LOS				C								

HCM 6th Signalized Intersection Summary  
2: Shiloh Road & Hembree Ln

GP 2040+Project Alternative A\_Mitigations  
Timing Plan: Saturday Middy Peak



Movement	EBL	EBT	EBR	WBL	WBT	WBR	NBL	NBT	NBR	SBL	SBT	SBR
Lane Configurations	↖↗	↕		↖↗	↕		↖	↗		↖	↕	↗↘
Traffic Volume (veh/h)	918	865	69	110	811	235	111	21	128	236	11	856
Future Volume (veh/h)	918	865	69	110	811	235	111	21	128	236	11	856
Initial Q (Qb), veh	0	0	0	0	0	0	0	0	0	0	0	0
Ped-Bike Adj(A_pbT)	1.00		1.00	1.00		1.00	1.00		1.00	1.00		1.00
Parking Bus, Adj	1.00	1.00	1.00	1.00	1.00	1.00	1.00	1.00	1.00	1.00	1.00	1.00
Work Zone On Approach		No			No			No			No	
Adj Sat Flow, veh/h/ln	1870	1870	1870	1870	1870	1870	1870	1870	1870	1870	1870	1870
Adj Flow Rate, veh/h	977	920	69	110	845	245	111	21	128	259	11	941
Peak Hour Factor	0.94	0.94	1.00	1.00	0.96	0.96	1.00	1.00	1.00	0.91	1.00	0.91
Percent Heavy Veh, %	2	2	2	2	2	2	2	2	2	2	2	2
Cap, veh/h	1009	1879	141	138	954	276	139	12	73	274	240	1173
Arrive On Green	0.29	0.56	0.56	0.08	0.35	0.35	0.08	0.05	0.05	0.15	0.13	0.13
Sat Flow, veh/h	3456	3351	251	1781	2717	787	1781	228	1392	1781	1870	2790
Grp Volume(v), veh/h	977	488	501	110	552	538	111	0	149	259	11	941
Grp Sat Flow(s),veh/h/ln	1728	1777	1825	1781	1777	1728	1781	0	1620	1781	1870	1395
Q Serve(g_s), s	29.6	17.6	17.6	6.4	31.1	31.1	6.5	0.0	5.6	15.3	0.5	13.6
Cycle Q Clear(g_c), s	29.6	17.6	17.6	6.4	31.1	31.1	6.5	0.0	5.6	15.3	0.5	13.6
Prop In Lane	1.00		0.14	1.00		0.46	1.00		0.86	1.00		1.00
Lane Grp Cap(c), veh/h	1009	997	1024	138	623	606	139	0	85	274	240	1173
V/C Ratio(X)	0.97	0.49	0.49	0.80	0.89	0.89	0.80	0.00	1.74	0.95	0.05	0.80
Avail Cap(c_a), veh/h	1009	997	1024	225	688	669	225	0	85	274	240	1173
HCM Platoon Ratio	1.00	1.00	1.00	1.00	1.00	1.00	1.00	1.00	1.00	1.00	1.00	1.00
Upstream Filter(I)	1.00	1.00	1.00	1.00	1.00	1.00	1.00	0.00	1.00	1.00	1.00	1.00
Uniform Delay (d), s/veh	37.1	14.1	14.1	48.2	32.4	32.5	48.1	0.0	50.3	44.5	40.6	26.9
Incr Delay (d2), s/veh	20.9	0.4	0.4	10.1	12.5	12.9	10.0	0.0	378.3	40.1	0.1	4.1
Initial Q Delay(d3),s/veh	0.0	0.0	0.0	0.0	0.0	0.0	0.0	0.0	0.0	0.0	0.0	0.0
%ile BackOfQ(50%),veh/ln	14.9	6.6	6.7	3.2	14.8	14.5	3.3	0.0	11.2	9.7	0.3	10.7
Unsig. Movement Delay, s/veh												
LnGrp Delay(d),s/veh	58.0	14.5	14.5	58.2	44.9	45.3	58.2	0.0	428.5	84.6	40.6	31.0
LnGrp LOS	E	B	B	E	D	D	E	A	F	F	D	C
Approach Vol, veh/h		1966			1200			260			1211	
Approach Delay, s/veh		36.1			46.3			270.4			42.6	
Approach LOS		D			D			F			D	
Timer - Assigned Phs	1	2	3	4	5	6	7	8				
Phs Duration (G+Y+Rc), s	12.7	63.5	12.3	17.6	35.0	41.2	20.3	9.6				
Change Period (Y+Rc), s	4.5	4.0	4.0	4.0	4.0	4.0	4.0	4.0				
Max Green Setting (Gmax), s	13.4	58.2	13.4	8.5	31.0	41.1	16.3	5.6				
Max Q Clear Time (g_c+1), s	19.4	19.6	8.5	15.6	31.6	33.1	17.3	7.6				
Green Ext Time (p_c), s	0.1	7.1	0.1	0.0	0.0	4.1	0.0	0.0				

Intersection Summary

HCM 6th Ctrl Delay	53.6
HCM 6th LOS	D

HCM 6th Signalized Intersection Summary  
 3: US 101 NB Off-Ramp & Shiloh Road

GP 2040+Project Alternative A\_Mitigations  
 Timing Plan: Saturday Midday Peak

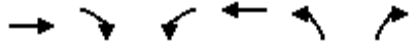

Movement	EBT	EBR	WBL	WBT	NBL	NBR
Lane Configurations	↑↑			↑↑	↘	↗↗
Traffic Volume (veh/h)	720	0	0	1243	520	1061
Future Volume (veh/h)	720	0	0	1243	520	1061
Initial Q (Qb), veh	0	0	0	0	0	0
Ped-Bike Adj(A_pbT)		1.00	1.00		1.00	1.00
Parking Bus, Adj	1.00	1.00	1.00	1.00	1.00	1.00
Work Zone On Approach	No			No	No	
Adj Sat Flow, veh/h/ln	1870	0	0	1870	1870	1870
Adj Flow Rate, veh/h	791	0	0	1397	547	1117
Peak Hour Factor	0.91	0.91	0.89	0.89	0.95	0.95
Percent Heavy Veh, %	2	0	0	2	2	2
Cap, veh/h	1612	0	0	1612	719	1127
Arrive On Green	0.45	0.00	0.00	0.45	0.40	0.40
Sat Flow, veh/h	3741	0	0	3741	1781	2790
Grp Volume(v), veh/h	791	0	0	1397	547	1117
Grp Sat Flow(s),veh/h/ln1777		0	0	1777	1781	1395
Q Serve(g_s), s	9.9	0.0	0.0	22.3	16.7	25.1
Cycle Q Clear(g_c), s	9.9	0.0	0.0	22.3	16.7	25.1
Prop In Lane		0.00	0.00		1.00	1.00
Lane Grp Cap(c), veh/h	1612	0	0	1612	719	1127
V/C Ratio(X)	0.49	0.00	0.00	0.87	0.76	0.99
Avail Cap(c_a), veh/h	1717	0	0	1717	719	1127
HCM Platoon Ratio	1.00	1.00	1.00	1.00	1.00	1.00
Upstream Filter(I)	1.00	0.00	0.00	1.00	1.00	1.00
Uniform Delay (d), s/veh	12.1	0.0	0.0	15.5	16.2	18.7
Incr Delay (d2), s/veh	0.2	0.0	0.0	4.8	4.7	24.6
Initial Q Delay(d3),s/veh	0.0	0.0	0.0	0.0	0.0	0.0
%ile BackOfQ(50%),veh/ln3.2		0.0	0.0	8.2	6.9	10.9
Unsig. Movement Delay, s/veh						
LnGrp Delay(d),s/veh	12.4	0.0	0.0	20.3	20.9	43.3
LnGrp LOS	B	A	A	C	C	D
Approach Vol, veh/h	791			1397	1664	
Approach Delay, s/veh	12.4			20.3	36.0	
Approach LOS	B			C	D	
Timer - Assigned Phs		2			6	8
Phs Duration (G+Y+Rc), s		33.1			33.1	30.0
Change Period (Y+Rc), s		4.5			4.5	4.5
Max Green Setting (Gmax), s		30.5			30.5	25.5
Max Q Clear Time (g_c+I1), s		11.9			24.3	27.1
Green Ext Time (p_c), s		5.0			4.3	0.0
<b>Intersection Summary</b>						
HCM 6th Ctrl Delay			25.4			
HCM 6th LOS			C			

Intersection						
Int Delay, s/veh	2.9					
Movement	EBT	EBR	WBL	WBT	NBL	NBR
Lane Configurations	↑↑		↘	↑↑	↘	↘
Traffic Vol, veh/h	826	30	120	911	24	115
Future Vol, veh/h	826	30	120	911	24	115
Conflicting Peds, #/hr	0	0	0	0	1	0
Sign Control	Free	Free	Free	Free	Stop	Stop
RT Channelized	-	None	-	None	-	None
Storage Length	-	-	68	-	0	0
Veh in Median Storage, #	0	-	-	0	0	-
Grade, %	0	-	-	0	0	-
Peak Hour Factor	92	92	87	87	78	78
Heavy Vehicles, %	2	2	2	2	2	2
Mvmt Flow	898	33	138	1047	31	147

Major/Minor	Major1	Major2	Minor1		
Conflicting Flow All	0	0	931	0	1716 466
Stage 1	-	-	-	-	915 -
Stage 2	-	-	-	-	801 -
Critical Hdwy	-	-	4.14	-	6.84 6.94
Critical Hdwy Stg 1	-	-	-	-	5.84 -
Critical Hdwy Stg 2	-	-	-	-	5.84 -
Follow-up Hdwy	-	-	2.22	-	3.52 3.32
Pot Cap-1 Maneuver	-	-	731	-	81 543
Stage 1	-	-	-	-	351 -
Stage 2	-	-	-	-	402 -
Platoon blocked, %	-	-	-	-	-
Mov Cap-1 Maneuver	-	-	731	-	66 543
Mov Cap-2 Maneuver	-	-	-	-	66 -
Stage 1	-	-	-	-	351 -
Stage 2	-	-	-	-	326 -

Approach	EB	WB	NB
HCM Control Delay, s	0	1.3	29
HCM LOS			D

Minor Lane/Major Mvmt	NBLn1	NBLn2	EBT	EBR	WBL	WBT
Capacity (veh/h)	66	543	-	-	731	-
HCM Lane V/C Ratio	0.466	0.272	-	-	0.189	-
HCM Control Delay (s)	100.3	14.1	-	-	11.1	-
HCM Lane LOS	F	B	-	-	B	-
HCM 95th %tile Q(veh)	1.8	1.1	-	-	0.7	-

HCM 6th Signalized Intersection Summary  
 7: Driveway 1/Gridley Drive & Shiloh Road

GP 2040+Project Alternative A\_Mitigations  
 Timing Plan: Saturday Midday Peak



Movement	EBL	EBT	EBR	WBL	WBT	WBR	NBL	NBT	NBR	SBL	SBT	SBR
Lane Configurations		↕	↗		↕		↖	↗			↕	
Traffic Volume (veh/h)	30	499	112	0	491	0	116	0	0	0	0	27
Future Volume (veh/h)	30	499	112	0	491	0	116	0	0	0	0	27
Initial Q (Qb), veh	0	0	0	0	0	0	0	0	0	0	0	0
Ped-Bike Adj(A_pbT)	1.00		0.99	1.00		1.00	1.00		1.00	1.00		1.00
Parking Bus, Adj	1.00	1.00	1.00	1.00	1.00	1.00	1.00	1.00	1.00	1.00	1.00	1.00
Work Zone On Approach		No		No		No		No		No		No
Adj Sat Flow, veh/h/ln	1870	1870	1870	1870	1870	1870	1870	1870	1870	1870	1870	1870
Adj Flow Rate, veh/h	32	537	120	0	558	0	116	0	0	0	0	48
Peak Hour Factor	0.93	0.93	0.93	0.88	0.88	0.88	1.00	1.00	1.00	0.56	0.56	0.56
Percent Heavy Veh, %	2	2	2	2	2	2	2	2	2	2	2	2
Cap, veh/h	126	740	667	0	798	0	562	534	0	0	0	452
Arrive On Green	0.43	0.43	0.43	0.00	0.43	0.00	0.29	0.00	0.00	0.00	0.00	0.29
Sat Flow, veh/h	42	1735	1564	0	1870	0	1357	1870	0	0	0	1585
Grp Volume(v), veh/h	569	0	120	0	558	0	116	0	0	0	0	48
Grp Sat Flow(s),veh/h/ln1777	0	1564	0	1870	0	1357	1870	0	0	0	0	1585
Q Serve(g_s), s	0.8	0.0	1.7	0.0	8.5	0.0	2.4	0.0	0.0	0.0	0.0	0.8
Cycle Q Clear(g_c), s	9.4	0.0	1.7	0.0	8.5	0.0	3.2	0.0	0.0	0.0	0.0	0.8
Prop In Lane	0.06		1.00	0.00		0.00	1.00		0.00	0.00		1.00
Lane Grp Cap(c), veh/h	867	0	667	0	798	0	562	534	0	0	0	452
V/C Ratio(X)	0.66	0.00	0.18	0.00	0.70	0.00	0.21	0.00	0.00	0.00	0.00	0.11
Avail Cap(c_a), veh/h	1449	0	1187	0	1419	0	1077	1243	0	0	0	1053
HCM Platoon Ratio	1.00	1.00	1.00	1.00	1.00	1.00	1.00	1.00	1.00	1.00	1.00	1.00
Upstream Filter(I)	1.00	0.00	1.00	0.00	1.00	0.00	1.00	0.00	0.00	0.00	0.00	1.00
Uniform Delay (d), s/veh	8.3	0.0	6.2	0.0	8.2	0.0	10.4	0.0	0.0	0.0	0.0	9.2
Incr Delay (d2), s/veh	0.9	0.0	0.1	0.0	1.1	0.0	0.2	0.0	0.0	0.0	0.0	0.1
Initial Q Delay(d3),s/veh	0.0	0.0	0.0	0.0	0.0	0.0	0.0	0.0	0.0	0.0	0.0	0.0
%ile BackOfQ(50%),veh/ln2.0	0.0	0.0	0.3	0.0	2.0	0.0	0.6	0.0	0.0	0.0	0.0	0.2
Unsig. Movement Delay, s/veh												
LnGrp Delay(d),s/veh	9.2	0.0	6.4	0.0	9.3	0.0	10.6	0.0	0.0	0.0	0.0	9.3
LnGrp LOS	A	A	A	A	A	A	B	A	A	A	A	A
Approach Vol, veh/h		689			558			116				48
Approach Delay, s/veh		8.7			9.3			10.6				9.3
Approach LOS		A			A			B				A
Timer - Assigned Phs		2		4		6		8				
Phs Duration (G+Y+Rc), s		14.7		20.4		14.7		20.4				
Change Period (Y+Rc), s		* 4.7		5.4		* 4.7		5.4				
Max Green Setting (Gmax), s		* 23		26.6		* 23		26.6				
Max Q Clear Time (g_c+11), s		5.2		11.4		2.8		10.5				
Green Ext Time (p_c), s		0.3		3.6		0.2		3.1				

Intersection Summary

HCM 6th Ctrl Delay	9.1
HCM 6th LOS	A

Notes

\* HCM 6th computational engine requires equal clearance times for the phases crossing the barrier.

HCM 6th Signalized Intersection Summary  
8: Old Redwood Hwy & Driveway 2

GP 2040+Project Alternative A\_Mitigations  
Timing Plan: Saturday Midday Peak



Movement	EBL	EBT	EBR	WBL	WBT	WBR	NBL	NBT	NBR	SBL	SBT	SBR
Lane Configurations		↕		↗	↘			↖	↗	↘	↖	↘
Traffic Volume (veh/h)	1	0	3	68	0	109	1	595	66	105	505	6
Future Volume (veh/h)	1	0	3	68	0	109	1	595	66	105	505	6
Initial Q (Qb), veh	0	0	0	0	0	0	0	0	0	0	0	0
Ped-Bike Adj(A_pbT)	1.00		1.00	1.00		1.00	1.00		0.98	1.00		0.97
Parking Bus, Adj	1.00	1.00	1.00	1.00	1.00	1.00	1.00	1.00	1.00	1.00	1.00	1.00
Work Zone On Approach		No			No			No			No	
Adj Sat Flow, veh/h/ln	1870	1870	1870	1870	1870	1870	1870	1870	1870	1870	1870	1870
Adj Flow Rate, veh/h	3	0	8	68	0	109	1	633	70	113	543	6
Peak Hour Factor	0.38	0.38	0.38	1.00	1.00	1.00	0.94	0.94	0.94	0.93	0.93	0.93
Percent Heavy Veh, %	2	2	2	2	2	2	2	2	2	2	2	2
Cap, veh/h	163	45	250	492	0	348	91	966	806	381	954	11
Arrive On Green	0.22	0.00	0.22	0.22	0.00	0.22	0.52	0.52	0.52	0.52	0.52	0.52
Sat Flow, veh/h	220	207	1138	1407	0	1585	0	1870	1560	744	1846	20
Grp Volume(v), veh/h	11	0	0	68	0	109	634	0	70	113	0	549
Grp Sat Flow(s),veh/h/ln1565		0	0	1407	0	1585	1870	0	1560	744	0	1866
Q Serve(g_s), s	0.0	0.0	0.0	1.3	0.0	2.3	0.0	0.0	0.9	5.2	0.0	8.0
Cycle Q Clear(g_c), s	0.2	0.0	0.0	1.5	0.0	2.3	9.9	0.0	0.9	15.1	0.0	8.0
Prop In Lane	0.27		0.73	1.00		1.00	0.00		1.00	1.00		0.01
Lane Grp Cap(c), veh/h	459	0	0	492	0	348	1057	0	806	381	0	964
V/C Ratio(X)	0.02	0.00	0.00	0.14	0.00	0.31	0.60	0.00	0.09	0.30	0.00	0.57
Avail Cap(c_a), veh/h	805	0	0	819	0	716	1568	0	1234	584	0	1475
HCM Platoon Ratio	1.00	1.00	1.00	1.00	1.00	1.00	1.00	1.00	1.00	1.00	1.00	1.00
Upstream Filter(I)	1.00	0.00	0.00	1.00	0.00	1.00	1.00	0.00	1.00	1.00	0.00	1.00
Uniform Delay (d), s/veh	12.2	0.0	0.0	12.7	0.0	13.0	7.0	0.0	4.9	12.6	0.0	6.6
Incr Delay (d2), s/veh	0.0	0.0	0.0	0.1	0.0	0.5	0.6	0.0	0.0	0.4	0.0	0.5
Initial Q Delay(d3),s/veh	0.0	0.0	0.0	0.0	0.0	0.0	0.0	0.0	0.0	0.0	0.0	0.0
%ile BackOfQ(50%),veh/ln0.1	0.0	0.0	0.0	0.4	0.0	0.7	1.9	0.0	0.1	0.6	0.0	1.5
Unsig. Movement Delay, s/veh												
LnGrp Delay(d),s/veh	12.2	0.0	0.0	12.8	0.0	13.5	7.6	0.0	4.9	13.0	0.0	7.1
LnGrp LOS	B	A	A	B	A	B	A	A	A	B	A	A
Approach Vol, veh/h		11			177			704			662	
Approach Delay, s/veh		12.2			13.3			7.3			8.1	
Approach LOS		B			B			A			A	
Timer - Assigned Phs		2		4		6		8				
Phs Duration (G+Y+Rc), s		26.4		13.5		26.4		13.5				
Change Period (Y+Rc), s		5.8		* 4.7		5.8		* 4.7				
Max Green Setting (Gmax), s		31.5		* 18		31.5		* 18				
Max Q Clear Time (g_c+11), s		11.9		2.2		17.1		4.3				
Green Ext Time (p_c), s		4.0		0.0		3.5		0.6				

Intersection Summary

HCM 6th Ctrl Delay	8.4
HCM 6th LOS	A

Notes

\* HCM 6th computational engine requires equal clearance times for the phases crossing the barrier.



HCM 6th Signalized Intersection Summary

GP 2040+Project Alternative A\_Mitigations

12: US 101 SB On Ramp/US 101 SB Off Ramp & Old Redwood Highway Timing Plan: Saturday Midday Peak



Movement	EBL	EBT	EBR	WBL	WBT	WBR	NBL	NBT	NBR	SBL	SBT	SBR
Lane Configurations		↑↑	↑	↑	↑↑					↑	↔	
Traffic Volume (veh/h)	0	713	543	632	1060	0	0	0	0	262	1	112
Future Volume (veh/h)	0	713	543	632	1060	0	0	0	0	262	1	112
Initial Q (Qb), veh	0	0	0	0	0	0				0	0	0
Ped-Bike Adj(A_pbT)	1.00		0.98	1.00		1.00				1.00		1.00
Parking Bus, Adj	1.00	1.00	1.00	1.00	1.00	1.00				1.00	1.00	1.00
Work Zone On Approach		No			No						No	
Adj Sat Flow, veh/h/ln	0	1870	1870	1870	1870	0				1870	1870	1870
Adj Flow Rate, veh/h	0	735	560	658	1104	0				260	146	0
Peak Hour Factor	0.97	0.97	0.97	0.96	0.96	0.96				0.72	0.72	0.72
Percent Heavy Veh, %	0	2	2	2	2	0				2	2	2
Cap, veh/h	0	1117	488	663	2618	0				291	305	
Arrive On Green	0.00	0.31	0.31	0.37	0.74	0.00				0.16	0.16	0.00
Sat Flow, veh/h	0	3647	1552	1781	3647	0				1781	1870	0
Grp Volume(v), veh/h	0	735	560	658	1104	0				260	146	0
Grp Sat Flow(s),veh/h/ln	0	1777	1552	1781	1777	0				1781	1870	0
Q Serve(g_s), s	0.0	16.1	28.3	33.1	10.7	0.0				12.9	6.4	0.0
Cycle Q Clear(g_c), s	0.0	16.1	28.3	33.1	10.7	0.0				12.9	6.4	0.0
Prop In Lane	0.00		1.00	1.00		0.00				1.00		0.00
Lane Grp Cap(c), veh/h	0	1117	488	663	2618	0				291	305	
V/C Ratio(X)	0.00	0.66	1.15	0.99	0.42	0.00				0.89	0.48	
Avail Cap(c_a), veh/h	0	1117	488	663	2618	0				291	305	
HCM Platoon Ratio	1.00	1.00	1.00	1.00	1.00	1.00				1.00	1.00	1.00
Upstream Filter(I)	0.00	1.00	1.00	1.00	1.00	0.00				1.00	1.00	0.00
Uniform Delay (d), s/veh	0.0	26.7	30.9	28.1	4.5	0.0				36.9	34.2	0.0
Incr Delay (d2), s/veh	0.0	3.0	88.0	32.9	0.5	0.0				27.5	1.2	0.0
Initial Q Delay(d3),s/veh	0.0	0.0	0.0	0.0	0.0	0.0				0.0	0.0	0.0
%ile BackOfQ(50%),veh/ln	0.0	7.0	21.9	19.2	3.0	0.0				7.7	2.9	0.0
Unsig. Movement Delay, s/veh												
LnGrp Delay(d),s/veh	0.0	29.7	118.9	61.1	5.0	0.0				64.4	35.3	0.0
LnGrp LOS		A	C	F	E	A				E	D	
Approach Vol, veh/h		1295			1762					406		
Approach Delay, s/veh		68.3			26.0					53.9		
Approach LOS		E			C					D		
Timer - Assigned Phs		2			5	6		8				
Phs Duration (G+Y+Rc), s		70.8			38.0	32.8		19.2				
Change Period (Y+Rc), s		4.5			4.5	4.5		4.5				
Max Green Setting (Gmax), s		66.3			33.5	28.3		14.7				
Max Q Clear Time (g_c+I1), s		12.7			35.1	30.3		14.9				
Green Ext Time (p_c), s		10.4			0.0	0.0		0.0				

Intersection Summary

HCM 6th Ctrl Delay	45.1
HCM 6th LOS	D

Notes

- User approved volume balancing among the lanes for turning movement.
- User approved ignoring U-Turning movement.
- Unsignalized Delay for [SBR] is excluded from calculations of the approach delay and intersection delay.

## Queues

## GP 2040+Project Alternative A\_Mitigations

## 7: Driveway 1/Gridley Drive &amp; Shiloh Road

Timing Plan: A.M. PEAK

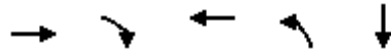

Lane Group	EBT	EBR	WBT	NBL	SBT
Lane Group Flow (vph)	401	52	220	33	35
v/c Ratio	0.52	0.08	0.28	0.10	0.09
Control Delay	8.4	2.0	6.0	10.4	5.1
Queue Delay	0.0	0.0	0.0	0.0	0.0
Total Delay	8.4	2.0	6.0	10.4	5.1
Queue Length 50th (ft)	32	0	16	3	0
Queue Length 95th (ft)	74	8	36	17	8
Internal Link Dist (ft)	528		2066		635
Turn Bay Length (ft)		150			
Base Capacity (vph)	1267	1093	1284	942	1118
Starvation Cap Reductn	0	0	0	0	0
Spillback Cap Reductn	0	0	0	0	0
Storage Cap Reductn	0	0	0	0	0
Reduced v/c Ratio	0.32	0.05	0.17	0.04	0.03

## Intersection Summary

Queues

12: US 101 SB On Ramp/US 101 SB Off Ramp & Old Redwood Highway



Lane Group	EBT	EBR	WBL	WBT	SBL	SBT
Lane Group Flow (vph)	651	533	498	1260	372	344
v/c Ratio	0.46	0.60	1.09	0.50	1.51	1.11
Control Delay	16.8	6.4	98.8	5.3	274.7	107.1
Queue Delay	0.0	0.0	0.0	0.0	0.0	0.0
Total Delay	16.8	6.4	98.8	5.3	274.7	107.1
Queue Length 50th (ft)	105	24	~248	101	~240	~140
Queue Length 95th (ft)	149	98	#412	133	#361	#262
Internal Link Dist (ft)	343			451		751
Turn Bay Length (ft)			250		420	
Base Capacity (vph)	1410	887	455	2522	247	311
Starvation Cap Reductn	0	0	0	0	0	0
Spillback Cap Reductn	0	0	0	0	0	0
Storage Cap Reductn	0	0	0	0	0	0
Reduced v/c Ratio	0.46	0.60	1.09	0.50	1.51	1.11

Intersection Summary

~ Volume exceeds capacity, queue is theoretically infinite.

Queue shown is maximum after two cycles.

# 95th percentile volume exceeds capacity, queue may be longer.

Queue shown is maximum after two cycles.

Queues  
6: Conde Lane & Shiloh Road

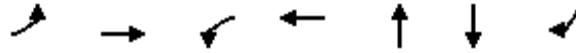

Lane Group	EBL	EBT	WBL	WBT	NBT	SBT	SBR
Lane Group Flow (vph)	45	578	14	1006	18	373	53
v/c Ratio	0.16	0.32	0.05	0.67	0.05	0.99	0.08
Control Delay	33.0	9.7	33.5	15.9	0.2	80.1	13.0
Queue Delay	0.0	0.0	0.0	0.0	0.0	0.0	0.0
Total Delay	33.0	9.7	33.5	15.9	0.2	80.1	13.0
Queue Length 50th (ft)	13	35	4	125	0	~143	10
Queue Length 95th (ft)	56	142	26	263	0	#392	31
Internal Link Dist (ft)		735		1001	338	442	
Turn Bay Length (ft)	90		127				65
Base Capacity (vph)	290	2693	272	2516	1073	375	1182
Starvation Cap Reductn	0	0	0	0	0	0	0
Spillback Cap Reductn	0	0	0	0	0	0	0
Storage Cap Reductn	0	0	0	0	0	0	0
Reduced v/c Ratio	0.16	0.21	0.05	0.40	0.02	0.99	0.04

Intersection Summary

- ~ Volume exceeds capacity, queue is theoretically infinite.  
Queue shown is maximum after two cycles.
- # 95th percentile volume exceeds capacity, queue may be longer.  
Queue shown is maximum after two cycles.

Lanes, Volumes, Timings  
1: Old Redwood Hwy & Shiloh Road

General Plan 2040 Project Altern. A Conditions

Timing Plan: A.M. PEAK

Lane Group	EBL	EBT	EBR	WBL	WBT	WBR	NBL	NBT	NBR	SBL	SBT	SBR
Lane Configurations												
Traffic Volume (vph)	313	310	440	40	242	29	364	312	18	53	479	398
Future Volume (vph)	313	310	440	40	242	29	364	312	18	53	479	398
Ideal Flow (vphpl)	1900	1900	1900	1900	1900	1900	1900	1900	1900	1900	1900	1900
Storage Length (ft)	375		140	0		50	200		98	130		93
Storage Lanes	1		1	0		1	1		1	1		1
Taper Length (ft)	50			25			60			93		
Lane Util. Factor	1.00	1.00	1.00	1.00	1.00	1.00	1.00	1.00	1.00	1.00	1.00	1.00
Ped Bike Factor												0.98
Frt			0.850			0.850			0.850			0.850
Flt Protected	0.950				0.993		0.950			0.950		
Satd. Flow (prot)	1770	1863	1583	0	1850	1583	1770	1863	1583	1770	1863	1583
Flt Permitted	0.950				0.993		0.950			0.950		
Satd. Flow (perm)	1770	1863	1583	0	1850	1583	1770	1863	1583	1770	1863	1549
Right Turn on Red			Yes			Yes			Yes			Yes
Satd. Flow (RTOR)			322			105			77			141
Link Speed (mph)		40			40			45			40	
Link Distance (ft)		1789			608			748			775	
Travel Time (s)		30.5			10.4			11.3			13.2	
Confl. Bikes (#/hr)												1
Peak Hour Factor	0.81	0.81	0.81	0.89	0.89	0.89	0.93	0.93	0.93	0.85	0.85	0.85
Adj. Flow (vph)	386	383	543	45	272	33	391	335	19	62	564	468
Shared Lane Traffic (%)												
Lane Group Flow (vph)	386	383	543	0	317	33	391	335	19	62	564	468
Enter Blocked Intersection	No	No	No	No	No	No	No	No	No	No	No	No
Lane Alignment	Left	Left	Right	Left	Left	Right	Left	Left	Right	Left	Left	Right
Median Width(ft)		12			12			12			12	
Link Offset(ft)		0			0			0			0	
Crosswalk Width(ft)		16			16			16			16	
Two way Left Turn Lane												
Headway Factor	1.00	1.00	1.00	1.00	1.00	1.00	1.00	1.00	1.00	1.00	1.00	1.00
Turning Speed (mph)	15		9	15		9	15		9	15		9
Number of Detectors	1	2	1	1	2	1	1	2	1	1	2	1
Detector Template	Left	Thru	Right	Left	Thru	Right	Left	Thru	Right	Left	Thru	Right
Leading Detector (ft)	20	100	20	20	100	20	20	100	20	20	100	20
Trailing Detector (ft)	0	0	0	0	0	0	0	0	0	0	0	0
Detector 1 Position(ft)	0	0	0	0	0	0	0	0	0	0	0	0
Detector 1 Size(ft)	20	6	20	20	6	20	20	6	20	20	6	20
Detector 1 Type	Cl+Ex	Cl+Ex	Cl+Ex	Cl+Ex	Cl+Ex	Cl+Ex	Cl+Ex	Cl+Ex	Cl+Ex	Cl+Ex	Cl+Ex	Cl+Ex
Detector 1 Channel												
Detector 1 Extend (s)	0.0	0.0	0.0	0.0	0.0	0.0	0.0	0.0	0.0	0.0	0.0	0.0
Detector 1 Queue (s)	0.0	0.0	0.0	0.0	0.0	0.0	0.0	0.0	0.0	0.0	0.0	0.0
Detector 1 Delay (s)	0.0	0.0	0.0	0.0	0.0	0.0	0.0	0.0	0.0	0.0	0.0	0.0
Detector 2 Position(ft)		94			94			94			94	
Detector 2 Size(ft)		6			6			6			6	
Detector 2 Type		Cl+Ex			Cl+Ex			Cl+Ex			Cl+Ex	
Detector 2 Channel												
Detector 2 Extend (s)		0.0			0.0			0.0			0.0	
Turn Type	Split	NA	Perm	Split	NA	Perm	Prot	NA	Perm	Prot	NA	Perm

Lanes, Volumes, Timings  
1: Old Redwood Hwy & Shiloh Road

General Plan 2040 Project Altern. A Conditions

Timing Plan: A.M. PEAK

Lane Group	EBL	EBT	EBR	WBL	WBT	WBR	NBL	NBT	NBR	SBL	SBT	SBR
Protected Phases	2	2		6	6		3	8		7	4	
Permitted Phases			2			6			8			4
Detector Phase	2	2	2	6	6	6	3	8	8	7	4	4
Switch Phase												
Minimum Initial (s)	5.0	5.0	5.0	5.0	5.0	5.0	5.0	5.0	5.0	5.0	5.0	5.0
Minimum Split (s)	34.5	34.5	34.5	42.5	42.5	42.5	8.5	46.5	46.5	8.5	39.5	39.5
Total Split (s)	35.0	35.0	35.0	42.5	42.5	42.5	18.0	48.0	48.0	9.5	39.5	39.5
Total Split (%)	25.9%	25.9%	25.9%	31.5%	31.5%	31.5%	13.3%	35.6%	35.6%	7.0%	29.3%	29.3%
Maximum Green (s)	30.5	30.5	30.5	38.0	38.0	38.0	14.5	43.5	43.5	6.0	35.0	35.0
Yellow Time (s)	3.5	3.5	3.5	3.5	3.5	3.5	3.0	3.5	3.5	3.0	3.5	3.5
All-Red Time (s)	1.0	1.0	1.0	1.0	1.0	1.0	0.5	1.0	1.0	0.5	1.0	1.0
Lost Time Adjust (s)	0.0	0.0	0.0		0.0	0.0	0.0	0.0	0.0	0.0	0.0	0.0
Total Lost Time (s)	4.5	4.5	4.5		4.5	4.5	3.5	4.5	4.5	3.5	4.5	4.5
Lead/Lag	Lead	Lead	Lead	Lag	Lag	Lag	Lead	Lag	Lag	Lead	Lag	Lag
Lead-Lag Optimize?	Yes	Yes	Yes	Yes	Yes	Yes	Yes	Yes	Yes	Yes	Yes	Yes
Vehicle Extension (s)	3.0	3.0	3.0	3.0	3.0	3.0	3.0	3.0	3.0	3.0	3.0	3.0
Recall Mode	None	None	None	None	None	None	None	None	None	None	None	None
Walk Time (s)	7.0	7.0	7.0	7.0	7.0	7.0		7.0	7.0		7.0	7.0
Flash Don't Walk (s)	23.0	23.0	23.0	31.0	31.0	31.0		35.0	35.0		28.0	28.0
Pedestrian Calls (#/hr)	0	0	0	0	0	0		0	0		0	0
Act Effct Green (s)	30.5	30.5	30.5		26.1	26.1	14.5	43.6	43.6	6.0	35.1	35.1
Actuated g/C Ratio	0.25	0.25	0.25		0.21	0.21	0.12	0.35	0.35	0.05	0.28	0.28
v/c Ratio	0.88	0.83	0.86		0.81	0.08	1.88	0.51	0.03	0.72	1.06	0.87
Control Delay (s/veh)	67.9	61.5	32.6		62.6	0.4	443.1	35.9	0.1	100.8	99.9	46.9
Queue Delay	0.0	0.0	0.0		0.0	0.0	0.0	0.0	0.0	0.0	0.0	0.0
Total Delay (s/veh)	67.9	61.5	32.6		62.6	0.4	443.1	35.9	0.1	100.8	99.9	46.9
LOS	E	E	C		E	A	F	D	A	F	F	D
Approach Delay (s/veh)		51.4			56.7			248.7			77.3	
Approach LOS		D			E			F			E	

Intersection Summary

Area Type:	Other
Cycle Length:	135
Actuated Cycle Length:	123.2
Natural Cycle:	145
Control Type:	Actuated-Uncoordinated
Maximum v/c Ratio:	1.88
Intersection Signal Delay (s/veh):	102.0
Intersection LOS:	F
Intersection Capacity Utilization:	92.2%
ICU Level of Service:	F
Analysis Period (min):	15



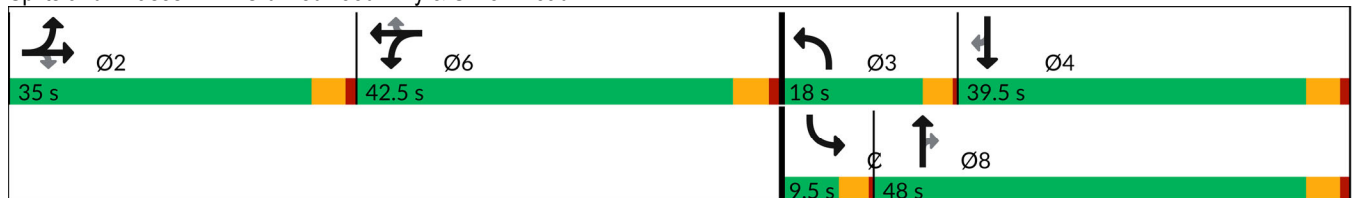



















Splits and Phases: 1: Old Redwood Hwy & Shiloh Road



Lanes, Volumes, Timings  
2: Shiloh Road & Hembree Ln

General Plan 2040 Project Altern. A Conditions

Timing Plan: A.M. PEAK

												
Lane Group	EBL	EBT	EBR	WBL	WBT	WBR	NBL	NBT	NBR	SBL	SBT	SBR
Lane Configurations	 				 						 	
Traffic Volume (vph)	311	918	103	49	865	90	49	11	16	129	18	570
Future Volume (vph)	311	918	103	49	865	90	49	11	16	129	18	570
Ideal Flow (vphpl)	1900	1900	1900	1900	1900	1900	1900	1900	1900	1900	1900	1900
Storage Length (ft)	0		0	100		130	0		0	0		0
Storage Lanes	2		0	1		1	1		0	0		1
Taper Length (ft)	25			50			25			25		
Lane Util. Factor	0.97	1.00	1.00	1.00	0.95	0.95	1.00	1.00	1.00	1.00	1.00	1.00
Frt		0.987			0.986			0.911				0.850
Flt Protected	0.950			0.950			0.950				0.958	
Satd. Flow (prot)	3433	1839	0	1770	3490	0	1770	1697	0	0	1785	1583
Flt Permitted	0.950			0.950			0.950				0.958	
Satd. Flow (perm)	3433	1839	0	1770	3490	0	1770	1697	0	0	1785	1583
Right Turn on Red			Yes			Yes			Yes			Yes
Satd. Flow (RTOR)		10			16			16				119
Link Speed (mph)		40			40			30				35
Link Distance (ft)		302			1789			216				381
Travel Time (s)		5.1			30.5			4.9				7.4
Peak Hour Factor	0.88	0.88	1.00	1.00	0.97	0.97	1.00	1.00	1.00	0.94	1.00	0.94
Adj. Flow (vph)	353	1043	103	49	892	93	49	11	16	137	18	606
Shared Lane Traffic (%)												
Lane Group Flow (vph)	353	1146	0	49	985	0	49	27	0	0	155	606
Enter Blocked Intersection	No	No	No	No	No	No	No	No	No	No	No	No
Lane Alignment	Left	Left	Right	Left	Left	Right	Left	Left	Right	Left	Left	Right
Median Width(ft)		24			24			12				12
Link Offset(ft)		0			0			0				0
Crosswalk Width(ft)		16			16			16				16
Two way Left Turn Lane												
Headway Factor	1.00	1.00	1.00	1.00	1.00	1.00	1.00	1.00	1.00	1.00	1.00	1.00
Turning Speed (mph)	15		60	60		9	60		60	15		9
Number of Detectors	1	2		1	2		1	2		1	2	1
Detector Template	Left	Thru		Left	Thru		Left	Thru		Left	Thru	Right
Leading Detector (ft)	20	100		20	100		20	100		20	100	20
Trailing Detector (ft)	0	0		0	0		0	0		0	0	0
Detector 1 Position(ft)	0	0		0	0		0	0		0	0	0
Detector 1 Size(ft)	20	6		20	6		20	6		20	6	20
Detector 1 Type	Cl+Ex	Cl+Ex		Cl+Ex	Cl+Ex		Cl+Ex	Cl+Ex		Cl+Ex	Cl+Ex	Cl+Ex
Detector 1 Channel												
Detector 1 Extend (s)	0.0	0.0		0.0	0.0		0.0	0.0		0.0	0.0	0.0
Detector 1 Queue (s)	0.0	0.0		0.0	0.0		0.0	0.0		0.0	0.0	0.0
Detector 1 Delay (s)	0.0	0.0		0.0	0.0		0.0	0.0		0.0	0.0	0.0
Detector 2 Position(ft)		94			94			94				94
Detector 2 Size(ft)		6			6			6				6
Detector 2 Type		Cl+Ex			Cl+Ex			Cl+Ex				Cl+Ex
Detector 2 Channel												
Detector 2 Extend (s)		0.0			0.0			0.0				0.0
Turn Type	Prot	NA		Prot	NA		Split	NA		Split	NA	pt+ov
Protected Phases	5	2		1	6		8	8		4	4	4
Permitted Phases												

Lanes, Volumes, Timings  
2: Shiloh Road & Hembree Ln

General Plan 2040 Project Altern. A Conditions

Timing Plan: A.M. PEAK

Lane Group	EBL	EBT	EBR	WBL	WBT	WBR	NBL	NBT	NBR	SBL	SBT	SBR
Detector Phase	5	2		1	6		8	8		4	4	4 5
Switch Phase												
Minimum Initial (s)	3.0	5.0		5.0	5.0		5.0	5.0		5.0	5.0	
Minimum Split (s)	7.5	9.5		9.5	43.5		9.5	9.5		9.5	9.5	
Total Split (s)	21.0	57.0		9.5	45.5		9.5	9.5		14.0	14.0	
Total Split (%)	23.3%	63.3%		10.6%	50.6%		10.6%	10.6%		15.6%	15.6%	
Maximum Green (s)	17.0	53.0		5.5	41.5		5.5	5.5		10.0	10.0	
Yellow Time (s)	3.0	3.0		3.0	3.0		3.0	3.0		3.0	3.0	
All-Red Time (s)	1.0	1.0		1.0	1.0		1.0	1.0		1.0	1.0	
Lost Time Adjust (s)	0.0	0.0		0.0	0.0		0.0	0.0			0.0	
Total Lost Time (s)	4.0	4.0		4.0	4.0		4.0	4.0			4.0	
Lead/Lag	Lead	Lag		Lead	Lag							
Lead-Lag Optimize?	Yes	Yes		Yes	Yes							
Vehicle Extension (s)	3.0	3.0		3.0	3.0		3.0	3.0		3.0	3.0	
Recall Mode	None	None		None	None		None	None		None	None	
Walk Time (s)					7.0							
Flash Don't Walk (s)					32.0							
Pedestrian Calls (#/hr)					1							
Act Effct Green (s)	17.2	53.5		5.5	37.6		5.5	5.5			10.1	28.2
Actuated g/C Ratio	0.20	0.63		0.07	0.45		0.07	0.07			0.12	0.33
v/c Ratio	0.51	0.98		0.42	0.63		0.42	0.21			0.73	1.00
Control Delay (s/veh)	34.1	40.8		51.9	20.0		51.9	28.9			58.9	59.3
Queue Delay	0.0	11.5		0.0	0.0		0.0	0.0			0.0	0.0
Total Delay (s/veh)	34.1	52.3		51.9	20.0		51.9	28.9			58.9	59.3
LOS	C	D		D	B		D	C			E	E
Approach Delay (s/veh)		48.0			21.5			43.7			59.2	
Approach LOS		D			C			D			E	

Intersection Summary

Area Type:	Other
Cycle Length:	90
Actuated Cycle Length:	84.3
Natural Cycle:	120
Control Type:	Actuated-Uncoordinated
Maximum v/c Ratio:	1.00
Intersection Signal Delay (s/veh):	42.3
Intersection LOS:	D
Intersection Capacity Utilization:	83.5%
ICU Level of Service:	E
Analysis Period (min):	15

Splits and Phases: 2: Shiloh Road & Hembree Ln





Lanes, Volumes, Timings  
3: US 101 NB Off-Ramp & Shiloh Road

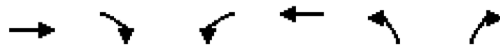

Lane Group	EBT	EBR	WBL	WBT	NBL	NBR
Lane Configurations	↑↑			↑	↘	↗↗
Traffic Volume (vph)	732	0	0	1103	813	601
Future Volume (vph)	732	0	0	1103	813	601
Ideal Flow (vphpl)	1900	1900	1900	1900	1900	1900
Storage Length (ft)		0	0		0	265
Storage Lanes		0	0		1	2
Taper Length (ft)			25		25	
Lane Util. Factor	0.95	1.00	1.00	1.00	1.00	0.88
Frt						0.850
Flt Protected					0.950	
Satd. Flow (prot)	3539	0	0	1863	1770	2787
Flt Permitted					0.950	
Satd. Flow (perm)	3539	0	0	1863	1770	2787
Right Turn on Red		Yes				Yes
Satd. Flow (RTOR)						188
Link Speed (mph)	40			40	30	
Link Distance (ft)	186			371	769	
Travel Time (s)	3.2			6.3	17.5	
Peak Hour Factor	0.91	0.91	0.90	0.90	0.76	0.76
Adj. Flow (vph)	804	0	0	1226	1070	791
Shared Lane Traffic (%)						
Lane Group Flow (vph)	804	0	0	1226	1070	791
Enter Blocked Intersection	No	No	No	No	No	No
Lane Alignment	Left	Right	Left	Left	Left	Right
Median Width(ft)	0			0	12	
Link Offset(ft)	0			0	0	
Crosswalk Width(ft)	16			16	16	
Two way Left Turn Lane						
Headway Factor	1.00	1.00	1.00	1.00	1.00	1.00
Turning Speed (mph)		9	15		15	9
Number of Detectors	2			2	1	1
Detector Template	Thru			Thru	Left	Right
Leading Detector (ft)	100			100	20	20
Trailing Detector (ft)	0			0	0	0
Detector 1 Position(ft)	0			0	0	0
Detector 1 Size(ft)	6			6	20	20
Detector 1 Type	Cl+Ex			Cl+Ex	Cl+Ex	Cl+Ex
Detector 1 Channel						
Detector 1 Extend (s)	0.0			0.0	0.0	0.0
Detector 1 Queue (s)	0.0			0.0	0.0	0.0
Detector 1 Delay (s)	0.0			0.0	0.0	0.0
Detector 2 Position(ft)	94			94		
Detector 2 Size(ft)	6			6		
Detector 2 Type	Cl+Ex			Cl+Ex		
Detector 2 Channel						
Detector 2 Extend (s)	0.0			0.0		
Turn Type	NA			NA	Prot	Perm
Protected Phases	2			6	8	
Permitted Phases						8

Lanes, Volumes, Timings  
 3: US 101 NB Off-Ramp & Shiloh Road



Lane Group	EBT	EBR	WBL	WBT	NBL	NBR
Detector Phase	2			6	8	8
Switch Phase						
Minimum Initial (s)	5.0			5.0	5.0	5.0
Minimum Split (s)	9.0			9.0	9.0	9.0
Total Split (s)	37.0			37.0	35.0	35.0
Total Split (%)	51.4%			51.4%	48.6%	48.6%
Maximum Green (s)	33.0			33.0	31.0	31.0
Yellow Time (s)	3.0			3.0	3.0	3.0
All-Red Time (s)	1.0			1.0	1.0	1.0
Lost Time Adjust (s)	0.0			0.0	0.0	0.0
Total Lost Time (s)	4.0			4.0	4.0	4.0
Lead/Lag						
Lead-Lag Optimize?						
Vehicle Extension (s)	3.0			3.0	3.0	3.0
Recall Mode	None			None	None	None
Act Effect Green (s)	33.0			33.0	31.0	31.0
Actuated g/C Ratio	0.46			0.46	0.43	0.43
v/c Ratio	0.50			1.44	1.40	0.61
Control Delay (s/veh)	15.0			225.6	212.4	14.1
Queue Delay	0.0			0.0	0.0	0.0
Total Delay (s/veh)	15.0			225.6	212.4	14.1
LOS	B			F	F	B
Approach Delay (s/veh)	15.0			225.6	128.1	
Approach LOS	B			F	F	

Intersection Summary

Area Type: Other  
 Cycle Length: 72  
 Actuated Cycle Length: 72  
 Natural Cycle: 130  
 Control Type: Actuated-Uncoordinated  
 Maximum v/c Ratio: 1.44  
 Intersection Signal Delay (s/veh): 135.5  
 Intersection LOS: F  
 Intersection Capacity Utilization 162.7%  
 ICU Level of Service H  
 Analysis Period (min) 15

Splits and Phases: 3: US 101 NB Off-Ramp & Shiloh Road

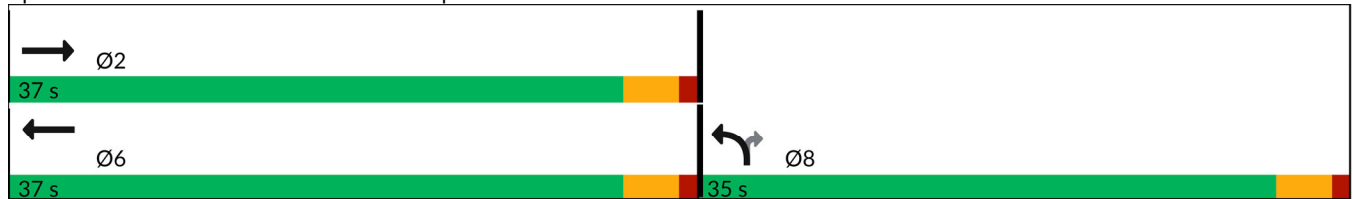

Lanes, Volumes, Timings  
4: Shiloh Road & US 101 SB Off-Ramp

General Plan 2040 Project Altern. A Conditions  
Timing Plan: A.M. PEAK



Lane Group	EBL	EBT	WBT	WBR	SBL	SBR
Lane Configurations		↑	↑		↘	↘
Traffic Volume (vph)	0	422	1153	0	310	184
Future Volume (vph)	0	422	1153	0	310	184
Ideal Flow (vphpl)	1900	1900	1900	1900	1900	1900
Storage Length (ft)	0			0	0	275
Storage Lanes	0			0	1	1
Taper Length (ft)	25				25	
Lane Util. Factor	1.00	1.00	1.00	1.00	1.00	1.00
Frt						0.850
Flt Protected					0.950	
Satd. Flow (prot)	0	1863	1863	0	1770	1583
Flt Permitted					0.950	
Satd. Flow (perm)	0	1863	1863	0	1770	1583
Right Turn on Red				Yes		Yes
Satd. Flow (RTOR)						107
Link Speed (mph)		40	40		30	
Link Distance (ft)		225	306		486	
Travel Time (s)		3.8	5.2		11.0	
Peak Hour Factor	0.93	0.93	0.91	0.91	0.92	0.92
Adj. Flow (vph)	0	454	1267	0	337	200
Shared Lane Traffic (%)						
Lane Group Flow (vph)	0	454	1267	0	337	200
Enter Blocked Intersection	No	No	No	No	No	No
Lane Alignment	Left	Left	Left	Right	Left	Right
Median Width(ft)		4	0		12	
Link Offset(ft)		0	0		0	
Crosswalk Width(ft)		16	16		16	
Two way Left Turn Lane						
Headway Factor	1.00	1.00	1.00	1.00	1.00	1.00
Turning Speed (mph)	15			9	15	9
Number of Detectors		2	2		1	1
Detector Template		Thru	Thru		Left	Right
Leading Detector (ft)		100	100		20	20
Trailing Detector (ft)		0	0		0	0
Detector 1 Position(ft)		0	0		0	0
Detector 1 Size(ft)		6	6		20	20
Detector 1 Type		Cl+Ex	Cl+Ex		Cl+Ex	Cl+Ex
Detector 1 Channel						
Detector 1 Extend (s)		0.0	0.0		0.0	0.0
Detector 1 Queue (s)		0.0	0.0		0.0	0.0
Detector 1 Delay (s)		0.0	0.0		0.0	0.0
Detector 2 Position(ft)		94	94			
Detector 2 Size(ft)		6	6			
Detector 2 Type		Cl+Ex	Cl+Ex			
Detector 2 Channel						
Detector 2 Extend (s)		0.0	0.0			
Turn Type		NA	NA		Perm	Perm
Protected Phases		2	6			
Permitted Phases					4	4

Lanes, Volumes, Timings  
4: Shiloh Road & US 101 SB Off-Ramp

General Plan 2040 Project Altern. A Conditions  
Timing Plan: A.M. PEAK



Lane Group	EBL	EBT	WBT	WBR	SBL	SBR
Detector Phase		2	6		4	4
Switch Phase						
Minimum Initial (s)		5.0	5.0		5.0	5.0
Minimum Split (s)		9.0	38.0		9.0	9.0
Total Split (s)		69.0	69.0		21.0	21.0
Total Split (%)		76.7%	76.7%		23.3%	23.3%
Maximum Green (s)		65.0	65.0		17.0	17.0
Yellow Time (s)		3.0	3.0		3.0	3.0
All-Red Time (s)		1.0	1.0		1.0	1.0
Lost Time Adjust (s)		0.0	0.0		0.0	0.0
Total Lost Time (s)		4.0	4.0		4.0	4.0
Lead/Lag						
Lead-Lag Optimize?						
Vehicle Extension (s)		3.0	3.0		3.0	3.0
Recall Mode		None	None		None	None
Walk Time (s)			7.0			
Flash Don't Walk (s)			27.0			
Pedestrian Calls (#/hr)			0			
Act Effct Green (s)		61.3	61.3		17.1	17.1
Actuated g/C Ratio		0.71	0.71		0.20	0.20
v/c Ratio		0.34	0.96		0.96	0.50
Control Delay (s/veh)		5.5	29.7		77.6	20.8
Queue Delay		0.0	0.0		0.0	0.0
Total Delay (s/veh)		5.5	29.7		77.6	20.8
LOS		A	C		E	C
Approach Delay (s/veh)		5.5	29.7		56.4	
Approach LOS		A	C		E	

Intersection Summary	
Area Type:	Other
Cycle Length:	90
Actuated Cycle Length:	86.5
Natural Cycle:	90
Control Type:	Actuated-Uncoordinated
Maximum v/c Ratio:	0.96
Intersection Signal Delay (s/veh):	31.2
Intersection LOS:	C
Intersection Capacity Utilization:	145.0%
ICU Level of Service:	H
Analysis Period (min):	15

Splits and Phases: 4: Shiloh Road & US 101 SB Off-Ramp

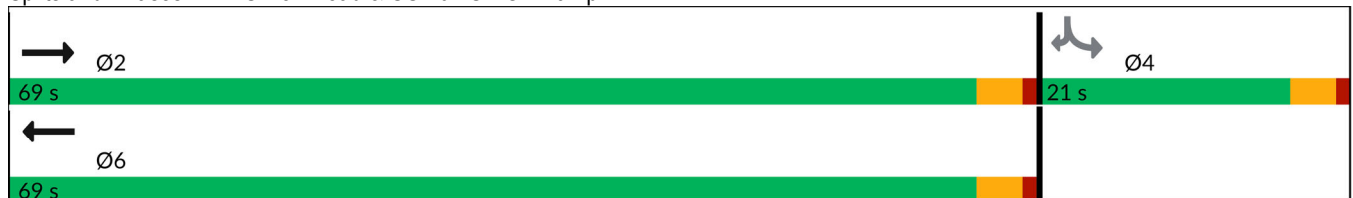

Lanes, Volumes, Timings  
5: Caletti Ave & Shiloh Road

General Plan 2040 Project Altern. A Conditions

Timing Plan: A.M. PEAK

	→	↘	↙	←	↖	↗
Lane Group	EBT	EBR	WBL	WBT	NBL	NBR
Lane Configurations	↑↑		↘	↑	↖	↗
Traffic Volume (vph)	900	14	130	1207	17	122
Future Volume (vph)	900	14	130	1207	17	122
Ideal Flow (vphpl)	1900	1900	1900	1900	1900	1900
Storage Length (ft)		0	68		0	0
Storage Lanes		0	1		1	1
Taper Length (ft)			50		25	
Lane Util. Factor	0.95	0.95	1.00	1.00	1.00	1.00
Frt	0.998					0.850
Flt Protected			0.950		0.950	
Satd. Flow (prot)	3532	0	1770	1863	1770	1583
Flt Permitted			0.950		0.950	
Satd. Flow (perm)	3532	0	1770	1863	1770	1583
Link Speed (mph)	40			40	30	
Link Distance (ft)	1081			184	459	
Travel Time (s)	18.4			3.1	10.4	
Peak Hour Factor	0.96	0.96	0.87	0.87	0.84	0.84
Adj. Flow (vph)	938	15	149	1387	20	145
Shared Lane Traffic (%)						
Lane Group Flow (vph)	953	0	149	1387	20	145
Enter Blocked Intersection	No	No	No	No	No	No
Lane Alignment	Left	Right	Left	Left	Left	Right
Median Width(ft)	12			12	12	
Link Offset(ft)	0			0	0	
Crosswalk Width(ft)	16			16	16	
Two way Left Turn Lane						
Headway Factor	1.00	1.00	1.00	1.00	1.00	1.00
Turning Speed (mph)		9	15		15	9
Sign Control	Free			Free	Stop	
<b>Intersection Summary</b>						
Area Type:	Other					
Control Type:	Unsignalized					
Intersection Capacity Utilization	73.5%			ICU Level of Service D		
Analysis Period (min)	15					

Lanes, Volumes, Timings  
6: Conde Lane & Shiloh Road

General Plan 2040 Project Altern. A Conditions

Timing Plan: A.M. PEAK

Lane Group	EBL	EBT	EBR	WBL	WBT	WBR	NBL	NBT	NBR	SBL	SBT	SBR
Lane Configurations												
Traffic Volume (vph)	55	535	3	8	854	298	2	1	9	363	0	27
Future Volume (vph)	55	535	3	8	854	298	2	1	9	363	0	27
Ideal Flow (vphpl)	1900	1900	1900	1900	1900	1900	1900	1900	1900	1900	1900	1900
Storage Length (ft)	90		0	127		0	0		0	0		40
Storage Lanes	1		0	1		0	0		0	0		1
Taper Length (ft)	70			40			25			25		
Lane Util. Factor	1.00	0.95	0.95	1.00	0.95	0.95	1.00	1.00	1.00	1.00	1.00	1.00
Frt		0.999			0.961			0.902				0.850
Flt Protected	0.950			0.950				0.991			0.950	
Satd. Flow (prot)	1770	3536	0	1770	3401	0	0	1665	0	0	1770	1583
Flt Permitted	0.950			0.950				0.991			0.950	
Satd. Flow (perm)	1770	3536	0	1770	3401	0	0	1665	0	0	1770	1583
Right Turn on Red			Yes			Yes			Yes			No
Satd. Flow (RTOR)		1			50			16				
Link Speed (mph)		40			40			30				35
Link Distance (ft)		815			1081			418				522
Travel Time (s)		13.9			18.4			9.5				10.2
Peak Hour Factor	0.95	0.95	0.95	0.85	0.85	0.85	0.57	0.57	0.57	0.86	0.86	0.86
Adj. Flow (vph)	58	563	3	9	1005	351	4	2	16	422	0	31
Shared Lane Traffic (%)												
Lane Group Flow (vph)	58	566	0	9	1356	0	0	22	0	0	422	31
Enter Blocked Intersection	No	No	No	No	No	No	No	No	No	No	No	No
Lane Alignment	Left	Left	Right	Left	Left	Right	Left	Left	Right	Left	Left	Right
Median Width(ft)		12			12			0				0
Link Offset(ft)		0			0			0				0
Crosswalk Width(ft)		16			16			16				16
Two way Left Turn Lane												
Headway Factor	1.00	1.00	1.00	1.00	1.00	1.00	1.00	1.00	1.00	1.00	1.00	1.00
Turning Speed (mph)	15		9	15		9	15		9	15		9
Number of Detectors	1	2		1	2		1	2		1	1	1
Detector Template	Left	Thru		Left	Thru		Left	Thru		Left	Thru	Right
Leading Detector (ft)	20	100		20	100		20	100		20	30	20
Trailing Detector (ft)	0	0		0	0		0	0		0	0	0
Detector 1 Position(ft)	0	0		0	0		0	0		0	0	0
Detector 1 Size(ft)	20	6		20	6		20	6		20	30	20
Detector 1 Type	Cl+Ex	Cl+Ex		Cl+Ex	Cl+Ex		Cl+Ex	Cl+Ex		Cl+Ex	Cl+Ex	Cl+Ex
Detector 1 Channel												
Detector 1 Extend (s)	0.0	0.0		0.0	0.0		0.0	0.0		0.0	0.0	0.0
Detector 1 Queue (s)	0.0	0.0		0.0	0.0		0.0	0.0		0.0	0.0	0.0
Detector 1 Delay (s)	0.0	0.0		0.0	0.0		0.0	0.0		0.0	0.0	0.0
Detector 2 Position(ft)		94			94			94				
Detector 2 Size(ft)		6			6			6				
Detector 2 Type		Cl+Ex			Cl+Ex			Cl+Ex				
Detector 2 Channel												
Detector 2 Extend (s)		0.0			0.0			0.0				
Turn Type	Prot	NA		Prot	NA		Split	NA		Split	NA	custom
Protected Phases	5	2		1	6		7	7		4	4	
Permitted Phases												6

Lanes, Volumes, Timings  
6: Conde Lane & Shiloh Road

General Plan 2040 Project Altern. A Conditions

Timing Plan: A.M. PEAK

Lane Group	EBL	EBT	EBR	WBL	WBT	WBR	NBL	NBT	NBR	SBL	SBT	SBR
Detector Phase	5	2		1	6		7	7		4	4	6
Switch Phase												
Minimum Initial (s)	8.0	8.0		8.0	8.0		10.0	10.0		11.0	11.0	8.0
Minimum Split (s)	12.0	46.0		12.0	12.0		37.0	37.0		15.0	15.0	12.0
Total Split (s)	13.0	46.0		12.0	45.0		37.0	37.0		15.0	15.0	45.0
Total Split (%)	11.8%	41.8%		10.9%	40.9%		33.6%	33.6%		13.6%	13.6%	40.9%
Maximum Green (s)	9.0	42.0		8.0	41.0		33.0	33.0		11.0	11.0	41.0
Yellow Time (s)	3.0	3.0		3.0	3.0		3.0	3.0		3.0	3.0	3.0
All-Red Time (s)	1.0	1.0		1.0	1.0		1.0	1.0		1.0	1.0	1.0
Lost Time Adjust (s)	0.0	0.0		0.0	0.0		0.0	0.0		0.0	0.0	0.0
Total Lost Time (s)	4.0	4.0		4.0	4.0		4.0	4.0		4.0	4.0	4.0
Lead/Lag	Lead	Lag		Lead	Lag							Lag
Lead-Lag Optimize?	Yes	Yes		Yes	Yes							Yes
Vehicle Extension (s)	3.0	3.0		3.0	3.0		3.0	3.0		3.0	3.0	3.0
Recall Mode	None	None		None	None		None	None		None	None	None
Walk Time (s)		7.0					7.0	7.0				
Flash Don't Walk (s)		35.0					26.0	26.0				
Pedestrian Calls (#/hr)		0					0	0				
Act Effct Green (s)	8.6	46.9		8.2	42.1		10.3			11.3	42.1	
Actuated g/C Ratio	0.12	0.64		0.11	0.58		0.14			0.15	0.58	
v/c Ratio	0.28	0.25		0.05	0.69		0.09			1.55	0.03	
Control Delay (s/veh)	37.6	7.7		35.8	15.7		20.8			290.6	11.2	
Queue Delay	0.0	0.0		0.0	0.0		0.0			0.0	0.0	
Total Delay (s/veh)	37.6	7.7		35.8	15.7		20.8			290.6	11.2	
LOS	D	A		D	B		C			F	B	
Approach Delay (s/veh)		10.5			15.8		20.8			271.5		
Approach LOS		B			B		C			F		

Intersection Summary

Area Type:	Other
Cycle Length:	110
Actuated Cycle Length:	73.2
Natural Cycle:	140
Control Type:	Actuated-Uncoordinated
Maximum v/c Ratio:	1.55
Intersection Signal Delay (s/veh):	61.5
Intersection LOS:	E
Intersection Capacity Utilization:	76.6%
ICU Level of Service:	D
Analysis Period (min):	15



















Splits and Phases: 6: Conde Lane & Shiloh Road



Lanes, Volumes, Timings  
7: Driveway 1/Gridley Drive & Shiloh Road

General Plan 2040 Project Altern. A Conditions

Timing Plan: A.M. PEAK

												
Lane Group	EBL	EBT	EBR	WBL	WBT	WBR	NBL	NBT	NBR	SBL	SBT	SBR
Lane Configurations												
Traffic Volume (vph)	12	353	47	0	187	0	33	0	0	1	0	24
Future Volume (vph)	12	353	47	0	187	0	33	0	0	1	0	24
Ideal Flow (vphp)	1900	1900	1900	1900	1900	1900	1900	1900	1900	1900	1900	1900
Storage Length (ft)	0		150	0		0	0		0	0		0
Storage Lanes	0		1	0		0	1		0	0		0
Taper Length (ft)	25			25			25			25		
Lane Util. Factor	1.00	1.00	1.00	1.00	1.00	1.00	1.00	1.00	1.00	1.00	1.00	1.00
Ped Bike Factor												
Frt			0.850									0.869
Flt Protected		0.998					0.950					0.999
Satd. Flow (prot)	0	1859	1583	0	1863	0	1770	1863	0	0	1617	0
Flt Permitted		0.998					0.950					0.999
Satd. Flow (perm)	0	1859	1583	0	1863	0	1770	1863	0	0	1617	0
Link Speed (mph)		40			40			30				30
Link Distance (ft)		608			2146			248				715
Travel Time (s)		10.4			36.6			5.6				16.3
Confl. Bikes (#/hr)			1									
Peak Hour Factor	0.91	0.91	0.91	0.85	0.85	0.85	1.00	1.00	1.00	0.71	0.71	0.71
Adj. Flow (vph)	13	388	52	0	220	0	33	0	0	1	0	34
Shared Lane Traffic (%)												
Lane Group Flow (vph)	0	401	52	0	220	0	33	0	0	0	35	0
Enter Blocked Intersection	No	No	No	No	No	No	No	No	No	No	No	No
Lane Alignment	Left	Left	Right	Left	Left	Right	Left	Left	Right	Left	Left	Right
Median Width(ft)		0			0			12				12
Link Offset(ft)		0			0			0				0
Crosswalk Width(ft)		16			16			16				16
Two way Left Turn Lane												
Headway Factor	1.00	1.00	1.00	1.00	1.00	1.00	1.00	1.00	1.00	1.00	1.00	1.00
Turning Speed (mph)	15		9	15		9	15		9	15		9
Sign Control		Free			Free			Stop				Stop

Intersection Summary





















Area Type:	Other
Control Type:	Unsignalized
Intersection Capacity Utilization	43.4%
ICU Level of Service	A
Analysis Period (min)	15



Lanes, Volumes, Timings  
8: Old Redwood Hwy & Driveway 2

General Plan 2040 Project Altern. A Conditions

Timing Plan: A.M. PEAK

												
Lane Group	EBL	EBT	EBR	WBL	WBT	WBR	NBL	NBT	NBR	SBL	SBT	SBR
Lane Configurations												
Traffic Volume (vph)	1	0	0	19	0	31	0	662	28	45	914	0
Future Volume (vph)	1	0	0	19	0	31	0	662	28	45	914	0
Ideal Flow (vphp)	1900	1900	1900	1900	1900	1900	1900	1900	1900	1900	1900	1900
Storage Length (ft)	0		0	0		0	0		100	50		0
Storage Lanes	0		0	1		0	0		1	1		0
Taper Length (ft)	25			25			25			25		
Lane Util. Factor	1.00	1.00	1.00	1.00	1.00	1.00	1.00	1.00	1.00	1.00	1.00	1.00
Ped Bike Factor												
Frt					0.850				0.850			
Flt Protected		0.950		0.950						0.950		
Satd. Flow (prot)	0	1770	0	1770	1583	0	0	1863	1583	1770	1863	0
Flt Permitted		0.950		0.950						0.950		
Satd. Flow (perm)	0	1770	0	1770	1583	0	0	1863	1583	1770	1863	0
Link Speed (mph)		30			30			45			45	
Link Distance (ft)		98			385			520			748	
Travel Time (s)		2.2			8.8			7.9			11.3	
Confl. Peds. (#/hr)									1	1		
Confl. Bikes (#/hr)									1			2
Peak Hour Factor	0.25	0.25	0.25	1.00	1.00	1.00	0.99	0.99	0.99	0.90	0.90	0.90
Adj. Flow (vph)	4	0	0	19	0	31	0	669	28	50	1016	0
Shared Lane Traffic (%)												
Lane Group Flow (vph)	0	4	0	19	31	0	0	669	28	50	1016	0
Enter Blocked Intersection	No	No	No	No	No	No	No	No	No	No	No	No
Lane Alignment	Left	Left	Right	Left	Left	Right	Left	Left	Right	Left	Left	Right
Median Width(ft)		12			12			12			12	
Link Offset(ft)		0			0			0			0	
Crosswalk Width(ft)		16			16			16			16	
Two way Left Turn Lane												
Headway Factor	1.00	1.00	1.00	1.00	1.00	1.00	1.00	1.00	1.00	1.00	1.00	1.00
Turning Speed (mph)	15		9	15		9	15		9	15		9
Sign Control		Stop			Stop			Free			Free	
<b>Intersection Summary</b>												
Area Type:	Other											
Control Type:	Unsignalized											
Intersection Capacity Utilization	65.1%						ICU Level of Service C					
Analysis Period (min)	15											

Lanes, Volumes, Timings  
9: Driveway 3 & Shiloh Road

General Plan 2040 Project Altern. A Conditions

Timing Plan: A.M. PEAK

	→	↘	↙	←	↖	↗
Lane Group	EBT	EBR	WBL	WBT	NBL	NBR
Lane Configurations	↑	↗		↖	↘	↗
Traffic Volume (vph)	207	145	14	77	101	10
Future Volume (vph)	207	145	14	77	101	10
Ideal Flow (vphpl)	1900	1900	1900	1900	1900	1900
Storage Length (ft)		200	0		0	0
Storage Lanes		1	0		1	1
Taper Length (ft)			25		25	
Lane Util. Factor	1.00	1.00	1.00	1.00	1.00	1.00
Frt		0.850				0.850
Flt Protected				0.992	0.950	
Satd. Flow (prot)	1863	1583	0	1848	1770	1583
Flt Permitted				0.992	0.950	
Satd. Flow (perm)	1863	1583	0	1848	1770	1583
Link Speed (mph)	40			40	30	
Link Distance (ft)	2146			134	402	
Travel Time (s)	36.6			2.3	9.1	
Peak Hour Factor	0.85	0.85	0.81	0.81	1.00	1.00
Adj. Flow (vph)	244	171	17	95	101	10
Shared Lane Traffic (%)						
Lane Group Flow (vph)	244	171	0	112	101	10
Enter Blocked Intersection	No	No	No	No	No	No
Lane Alignment	Left	Right	Left	Left	Left	Right
Median Width(ft)	0			0	12	
Link Offset(ft)	0			0	0	
Crosswalk Width(ft)	16			16	16	
Two way Left Turn Lane						
Headway Factor	1.00	1.00	1.00	1.00	1.00	1.00
Turning Speed (mph)		9	15		15	9
Sign Control	Free			Free	Stop	
<b>Intersection Summary</b>						
Area Type:	Other					
Control Type:	Unsignalized					
Intersection Capacity Utilization	28.2%			ICU Level of Service A		
Analysis Period (min)	15					

Lanes, Volumes, Timings

General Plan 2040 Project Altern. A Conditions

10: US 101 NB Off Ramp/Lakewood Drive & Old Redwood Highway

Timing Plan: A.M. PEAK



Lane Group	EBL	EBT	EBR	WBL	WBT	WBR	NBL	NBT	NBR	SBL	SBT	SBR
Lane Configurations												
Traffic Volume (vph)	264	638	0	0	669	156	224	255	92	255	0	679
Future Volume (vph)	264	638	0	0	669	156	224	255	92	255	0	679
Ideal Flow (vphpl)	1900	1900	1900	1900	1900	1900	1900	1900	1900	1900	1900	1900
Storage Length (ft)	155		0	0		0	270		150	120		0
Storage Lanes	1		0	0		0	1		1	1		1
Taper Length (ft)	50			25			165			75		
Lane Util. Factor	0.97	1.00	1.00	1.00	0.95	0.95	0.91	0.91	0.95	0.97	1.00	1.00
Ped Bike Factor	1.00				1.00			1.00		1.00		
Flt					0.972			0.964				0.850
Flt Protected	0.950						0.950	0.996		0.950		
Satd. Flow (prot)	3433	1863	0	0	3431	0	1610	3244	0	3433	0	1583
Flt Permitted	0.950						0.950	0.996		0.950		
Satd. Flow (perm)	3431	1863	0	0	3431	0	1610	3244	0	3427	0	1583
Right Turn on Red			Yes			Yes			Yes			Yes
Satd. Flow (RTOR)					32			46				247
Link Speed (mph)		35			35			30				30
Link Distance (ft)		226			617			716				478
Travel Time (s)		4.4			12.0			16.3				10.9
Confl. Peds. (#/hr)	1		1	1		1			2	2		
Confl. Bikes (#/hr)			1			1						
Peak Hour Factor	0.85	0.85	0.85	0.83	0.83	0.83	0.90	0.90	0.90	0.89	0.89	0.89
Adj. Flow (vph)	311	751	0	0	806	188	249	283	102	287	0	763
Shared Lane Traffic (%)							15%					
Lane Group Flow (vph)	311	751	0	0	994	0	212	422	0	287	0	763
Enter Blocked Intersection	No	No	No	No	No	No	No	No	No	No	No	No
Lane Alignment	Left	Left	Right	Left	Left	Right	Left	Left	Right	Left	Left	Right
Median Width(ft)		24			24			24				24
Link Offset(ft)		0			0			0				0
Crosswalk Width(ft)		16			16			16				16
Two way Left Turn Lane												
Headway Factor	1.00	1.00	1.00	1.00	1.00	1.00	1.00	1.00	1.00	1.00	1.00	1.00
Turning Speed (mph)	15		9	15		9	15		9	15		9
Number of Detectors	1	2			2		1	2		1		1
Detector Template	Left	Thru			Thru		Left	Thru		Left		Right
Leading Detector (ft)	20	100			100		20	100		20		20
Trailing Detector (ft)	0	0			0		0	0		0		0
Detector 1 Position(ft)	0	0			0		0	0		0		0
Detector 1 Size(ft)	20	6			6		20	6		20		20
Detector 1 Type	Cl+Ex	Cl+Ex			Cl+Ex		Cl+Ex	Cl+Ex		Cl+Ex		Cl+Ex
Detector 1 Channel												
Detector 1 Extend (s)	0.0	0.0			0.0		0.0	0.0		0.0		0.0
Detector 1 Queue (s)	0.0	0.0			0.0		0.0	0.0		0.0		0.0
Detector 1 Delay (s)	0.0	0.0			0.0		0.0	0.0		0.0		0.0
Detector 2 Position(ft)		94			94			94				
Detector 2 Size(ft)		6			6			6				
Detector 2 Type		Cl+Ex			Cl+Ex			Cl+Ex				
Detector 2 Channel												
Detector 2 Extend (s)		0.0			0.0			0.0				

Lanes, Volumes, Timings

General Plan 2040 Project Altern. A Conditions

10: US 101 NB Off Ramp/Lakewood Drive & Old Redwood Highway

Timing Plan: A.M. PEAK



Lane Group	EBL	EBT	EBR	WBL	WBT	WBR	NBL	NBT	NBR	SBL	SBT	SBR
Turn Type	Prot	NA			NA		Split	NA		Prot		pm+ov
Protected Phases	5	2			6		8	8		7		5
Permitted Phases												5 8
Detector Phase	5	2			6		8	8		7		5
Switch Phase												
Minimum Initial (s)	7.0	10.0			10.0		10.0	10.0		7.0		7.0
Minimum Split (s)	11.0	32.1			32.1		33.7	33.7		11.0		11.0
Total Split (s)	13.0	45.3			32.3		33.7	33.7		11.0		13.0
Total Split (%)	14.4%	50.3%			35.9%		37.4%	37.4%		12.2%		14.4%
Maximum Green (s)	9.0	40.2			27.2		29.0	29.0		7.0		9.0
Yellow Time (s)	3.0	4.1			4.1		3.7	3.7		3.0		3.0
All-Red Time (s)	1.0	1.0			1.0		1.0	1.0		1.0		1.0
Lost Time Adjust (s)	0.0	0.0			0.0		0.0	0.0		0.0		0.0
Total Lost Time (s)	4.0	5.1			5.1		4.7	4.7		4.0		4.0
Lead/Lag	Lead				Lag		Lag	Lag		Lead		Lead
Lead-Lag Optimize?	Yes				Yes		Yes	Yes		Yes		Yes
Vehicle Extension (s)	3.0	3.0			3.0		3.0	3.0		3.0		3.0
Recall Mode	None	Max			Max		None	None		None		None
Walk Time (s)		7.0			7.0		7.0	7.0				
Flash Don't Walk (s)		20.0			17.0		22.0	22.0				
Pedestrian Calls (#/hr)		0			0		0	0				
Act Effct Green (s)	9.0	40.4			27.3		17.0	17.0		7.0		30.8
Actuated g/C Ratio	0.11	0.52			0.35		0.22	0.22		0.09		0.39
v/c Ratio	0.79	0.78			0.82		0.61	0.57		0.93		0.99
Control Delay (s/veh)	50.6	24.2			30.3		35.0	27.0		75.7		47.3
Queue Delay	0.0	0.0			0.0		0.0	0.0		0.0		0.0
Total Delay (s/veh)	50.6	24.2			30.3		35.0	27.0		75.7		47.3
LOS	D	C			C		D	C		E		D
Approach Delay (s/veh)		32.0			30.3			29.7				55.0
Approach LOS		C			C			C				E

Intersection Summary

Area Type: Other  
 Cycle Length: 90  
 Actuated Cycle Length: 78.3  
 Natural Cycle: 90  
 Control Type: Actuated-Uncoordinated  
 Maximum v/c Ratio: 0.99  
 Intersection Signal Delay (s/veh): 37.6  
 Intersection LOS: D  
 Intersection Capacity Utilization 88.9%  
 ICU Level of Service E  
 Analysis Period (min) 15

Splits and Phases: 10: US 101 NB Off Ramp/Lakewood Drive & Old Redwood Highway

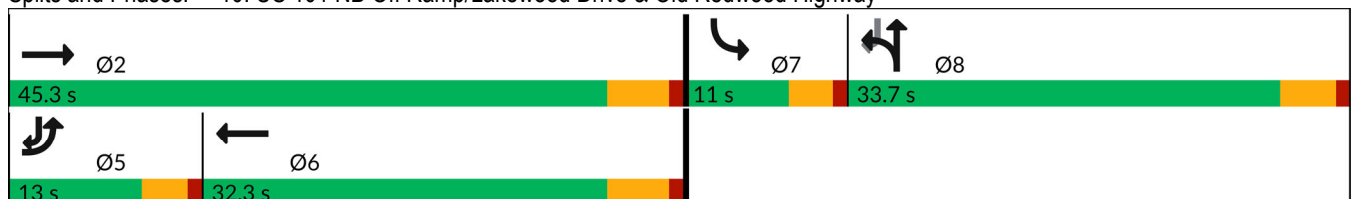

Lanes, Volumes, Timings  
 11: Old Redwood Highway & US 101 NB On Ramp

General Plan 2040 Project Altern. A Conditions

Timing Plan: A.M. PEAK

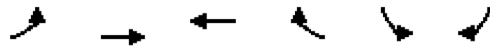

Lane Group	EBL	EBT	WBT	WBR	SBL	SBR
Lane Configurations						
Traffic Volume (vph)	0	902	1301	252	0	0
Future Volume (vph)	0	902	1301	252	0	0
Ideal Flow (vphpl)	1900	1900	1900	1900	1900	1900
Storage Length (ft)	245			0	0	0
Storage Lanes	1			0	0	0
Taper Length (ft)	50				25	
Lane Util. Factor	1.00	0.95	0.95	0.95	1.00	1.00
Ped Bike Factor						
Frt			0.976			
Flt Protected						
Satd. Flow (prot)	1863	3539	3454	0	0	0
Flt Permitted						
Satd. Flow (perm)	1863	3539	3454	0	0	0
Link Speed (mph)		35	35		30	
Link Distance (ft)		531	226		299	
Travel Time (s)		10.3	4.4		6.8	
Confl. Peds. (#/hr)	9					
Confl. Bikes (#/hr)				1		
Peak Hour Factor	0.81	0.81	0.89	0.89	0.25	0.25
Adj. Flow (vph)	0	1114	1462	283	0	0
Shared Lane Traffic (%)						
Lane Group Flow (vph)	0	1114	1745	0	0	0
Enter Blocked Intersection	No	No	No	No	No	No
Lane Alignment	Left	Left	Left	Right	Left	Right
Median Width(ft)		12	12		0	
Link Offset(ft)		0	0		0	
Crosswalk Width(ft)		16	16		16	
Two way Left Turn Lane						
Headway Factor	1.00	1.00	1.00	1.00	1.00	1.00
Turning Speed (mph)	15			9	15	9
Sign Control		Free	Free		Free	

Intersection Summary

Area Type:	Other
Control Type:	Unsignalized
Intersection Capacity Utilization	102.7%
Analysis Period (min)	15
	ICU Level of Service G

Lanes, Volumes, Timings

General Plan 2040 Project Altern. A Conditions

12: US 101 SB On Ramp/US 101 SB Off Ramp & Old Redwood Highway

Timing Plan: A.M. PEAK



Lane Group	EBL	EBT	EBR	WBL	WBT	WBR	NBL	NBT	NBR	SBL	SBT	SBR
Lane Configurations		↑↑	↗	↘	↑↑					↘	↔	
Traffic Volume (vph)	0	699	814	559	742	0	0	0	0	185	0	144
Future Volume (vph)	0	699	814	559	742	0	0	0	0	185	0	144
Ideal Flow (vphpl)	1900	1900	1900	1900	1900	1900	1900	1900	1900	1900	1900	1900
Storage Length (ft)	0		0	250		0	0		0	420		0
Storage Lanes	0		1	0		0	0		0	1		0
Taper Length (ft)	25			165			25			75		
Lane Util. Factor	1.00	0.95	1.00	1.00	0.95	1.00	1.00	1.00	1.00	0.95	0.95	1.00
Ped Bike Factor			0.98	1.00								
Frt			0.850								0.867	
Flt Protected				0.950						0.950	0.994	
Satd. Flow (prot)	0	3539	1583	1770	3539	0	0	0	0	1681	1525	0
Flt Permitted				0.950						0.950	0.994	
Satd. Flow (perm)	0	3539	1558	1768	3539	0	0	0	0	1681	1525	0
Right Turn on Red			Yes			Yes			Yes			Yes
Satd. Flow (RTOR)			361									178
Link Speed (mph)		35			35			30			30	
Link Distance (ft)		423			531			621			831	
Travel Time (s)		8.2			10.3			14.1			18.9	
Confl. Peds. (#/hr)	10		3	3		10						
Confl. Bikes (#/hr)			2									
Peak Hour Factor	0.92	0.92	0.92	0.89	0.89	0.89	0.25	0.25	0.25	0.81	0.81	0.81
Adj. Flow (vph)	0	760	885	628	834	0	0	0	0	228	0	178
Shared Lane Traffic (%)										10%		
Lane Group Flow (vph)	0	760	885	628	834	0	0	0	0	205	201	0
Enter Blocked Intersection	No	No	No	No	No	No	No	No	No	No	No	No
Lane Alignment	Left	Left	Right	Left	Left	Right	Left	Left	Right	Left	Left	Right
Median Width(ft)		24			24			12			12	
Link Offset(ft)		0			0			0			0	
Crosswalk Width(ft)		16			16			16			16	
Two way Left Turn Lane												
Headway Factor	1.00	1.00	1.00	1.00	1.00	1.00	1.00	1.00	1.00	1.00	1.00	1.00
Turning Speed (mph)	15		9	15		9	15		9	15		9
Number of Detectors		2	1	1	2					1	2	
Detector Template		Thru	Right	Left	Thru					Left	Thru	
Leading Detector (ft)		100	20	20	100					20	100	
Trailing Detector (ft)		0	0	0	0					0	0	
Detector 1 Position(ft)		0	0	0	0					0	0	
Detector 1 Size(ft)		6	20	20	6					20	6	
Detector 1 Type		Cl+Ex	Cl+Ex	Cl+Ex	Cl+Ex					Cl+Ex	Cl+Ex	
Detector 1 Channel												
Detector 1 Extend (s)		0.0	0.0	0.0	0.0					0.0	0.0	
Detector 1 Queue (s)		0.0	0.0	0.0	0.0					0.0	0.0	
Detector 1 Delay (s)		0.0	0.0	0.0	0.0					0.0	0.0	
Detector 2 Position(ft)		94			94							94
Detector 2 Size(ft)		6			6							6
Detector 2 Type		Cl+Ex			Cl+Ex							Cl+Ex
Detector 2 Channel												
Detector 2 Extend (s)		0.0			0.0							0.0

Lanes, Volumes, Timings

General Plan 2040 Project Altern. A Conditions

12: US 101 SB On Ramp/US 101 SB Off Ramp & Old Redwood Highway

Timing Plan: A.M. PEAK



Lane Group	EBL	EBT	EBR	WBL	WBT	WBR	NBL	NBT	NBR	SBL	SBT	SBR
Turn Type		NA	Perm	Prot	NA					Perm	NA	
Protected Phases		6		5	2						8	
Permitted Phases			6							8		
Detector Phase		6	6	5	2					8	8	
Switch Phase												
Minimum Initial (s)		10.0	10.0	7.0	10.0					10.0	10.0	
Minimum Split (s)		32.1	32.1	11.0	38.1					14.7	14.7	
Total Split (s)		32.3	32.3	33.0	65.3					14.7	14.7	
Total Split (%)		40.4%	40.4%	41.3%	81.6%					18.4%	18.4%	
Maximum Green (s)		27.2	27.2	29.0	60.2					10.0	10.0	
Yellow Time (s)		4.1	4.1	3.0	4.1					3.7	3.7	
All-Red Time (s)		1.0	1.0	1.0	1.0					1.0	1.0	
Lost Time Adjust (s)		0.0	0.0	0.0	0.0					0.0	0.0	
Total Lost Time (s)		5.1	5.1	4.0	5.1					4.7	4.7	
Lead/Lag		Lag	Lag	Lead								
Lead-Lag Optimize?		Yes	Yes	Yes								
Vehicle Extension (s)		3.0	3.0	3.0	3.0					3.0	3.0	
Recall Mode		Max	Max	None	Max					None	None	
Walk Time (s)		7.0	7.0		7.0							
Flash Don't Walk (s)		20.0	20.0		25.0							
Pedestrian Calls (#/hr)		0	0		0							
Act Effct Green (s)		27.2	27.2	29.0	60.2					10.0	10.0	
Actuated g/C Ratio		0.34	0.34	0.36	0.75					0.13	0.13	
v/c Ratio		0.63	1.15	0.98	0.31					0.98	0.58	
Control Delay (s/veh)		25.1	101.9	58.5	3.6					94.8	15.0	
Queue Delay		0.0	0.0	0.0	0.0					0.0	0.0	
Total Delay (s/veh)		25.1	101.9	58.5	3.6					94.8	15.0	
LOS		C	F	E	A					F	B	
Approach Delay (s/veh)		66.4			27.1						55.3	
Approach LOS		E			C						E	

Intersection Summary

Area Type: Other

Cycle Length: 80

Actuated Cycle Length: 80

Natural Cycle: 120

Control Type: Actuated-Uncoordinated

Maximum v/c Ratio: 1.15

Intersection Signal Delay (s/veh): 48.8

Intersection LOS: D

Intersection Capacity Utilization 102.7%

ICU Level of Service G

Analysis Period (min) 15



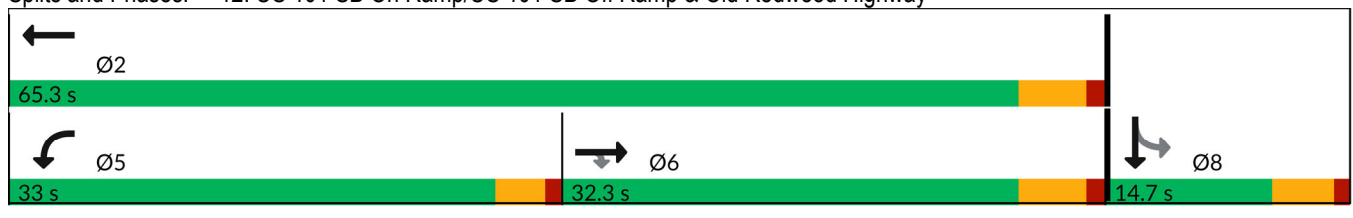



















Splits and Phases: 12: US 101 SB On Ramp/US 101 SB Off Ramp & Old Redwood Highway



Lanes, Volumes, Timings  
1: Old Redwood Hwy & Shiloh Road

General Plan 2040 Project Altern. A Conditions

Timing Plan: P.M. Peak

												
Lane Group	EBL	EBT	EBR	WBL	WBT	WBR	NBL	NBT	NBR	SBL	SBT	SBR
Lane Configurations												
Traffic Volume (vph)	317	558	672	44	442	70	667	567	44	100	550	265
Future Volume (vph)	317	558	672	44	442	70	667	567	44	100	550	265
Ideal Flow (vphpl)	1900	1900	1900	1900	1900	1900	1900	1900	1900	1900	1900	1900
Storage Length (ft)	375		140	0		50	200		98	130		93
Storage Lanes	1		1	0		1	1		1	1		1
Taper Length (ft)	50			25			60			93		
Lane Util. Factor	1.00	1.00	1.00	1.00	1.00	1.00	1.00	1.00	1.00	1.00	1.00	1.00
Ped Bike Factor	1.00					0.98	1.00		0.98			0.97
Frt			0.850			0.850			0.850			0.850
Flt Protected	0.950				0.996		0.950			0.950		
Satd. Flow (prot)	1770	1863	1583	0	1855	1583	1770	1863	1583	1770	1863	1583
Flt Permitted	0.950				0.996		0.950			0.950		
Satd. Flow (perm)	1768	1863	1583	0	1855	1549	1768	1863	1546	1770	1863	1542
Right Turn on Red			Yes			Yes			Yes			Yes
Satd. Flow (RTOR)			274			105			77			105
Link Speed (mph)		40			40			45			40	
Link Distance (ft)		1789			608			748			775	
Travel Time (s)		30.5			10.4			11.3			13.2	
Confl. Peds. (#/hr)	1						1	1				1
Confl. Bikes (#/hr)									3			3
Peak Hour Factor	0.97	0.97	0.97	0.91	0.91	0.91	0.93	0.93	0.93	0.93	0.93	0.93
Adj. Flow (vph)	327	575	693	48	486	77	717	610	47	108	591	285
Shared Lane Traffic (%)												
Lane Group Flow (vph)	327	575	693	0	534	77	717	610	47	108	591	285
Enter Blocked Intersection	No	No	No	No	No	No	No	No	No	No	No	No
Lane Alignment	Left	Left	Right	Left	Left	Right	Left	Left	Right	Left	Left	Right
Median Width(ft)		12			12			12			12	
Link Offset(ft)		0			0			0			0	
Crosswalk Width(ft)		16			16			16			16	
Two way Left Turn Lane												
Headway Factor	1.00	1.00	1.00	1.00	1.00	1.00	1.00	1.00	1.00	1.00	1.00	1.00
Turning Speed (mph)	15		9	15		9	15		9	15		9
Number of Detectors	1	2	1	1	2	1	1	2	1	1	2	1
Detector Template	Left	Thru	Right	Left	Thru	Right	Left	Thru	Right	Left	Thru	Right
Leading Detector (ft)	20	100	20	20	100	20	20	100	20	20	100	20
Trailing Detector (ft)	0	0	0	0	0	0	0	0	0	0	0	0
Detector 1 Position(ft)	0	0	0	0	0	0	0	0	0	0	0	0
Detector 1 Size(ft)	20	6	20	20	6	20	20	6	20	20	6	20
Detector 1 Type	Cl+Ex	Cl+Ex	Cl+Ex	Cl+Ex	Cl+Ex	Cl+Ex	Cl+Ex	Cl+Ex	Cl+Ex	Cl+Ex	Cl+Ex	Cl+Ex
Detector 1 Channel												
Detector 1 Extend (s)	0.0	0.0	0.0	0.0	0.0	0.0	0.0	0.0	0.0	0.0	0.0	0.0
Detector 1 Queue (s)	0.0	0.0	0.0	0.0	0.0	0.0	0.0	0.0	0.0	0.0	0.0	0.0
Detector 1 Delay (s)	0.0	0.0	0.0	0.0	0.0	0.0	0.0	0.0	0.0	0.0	0.0	0.0
Detector 2 Position(ft)		94			94			94			94	
Detector 2 Size(ft)		6			6			6			6	
Detector 2 Type		Cl+Ex			Cl+Ex			Cl+Ex			Cl+Ex	
Detector 2 Channel												
Detector 2 Extend (s)		0.0			0.0			0.0			0.0	



Lanes, Volumes, Timings  
1: Old Redwood Hwy & Shiloh Road

General Plan 2040 Project Altern. A Conditions

Timing Plan: P.M. Peak

Lane Group	EBL	EBT	EBR	WBL	WBT	WBR	NBL	NBT	NBR	SBL	SBT	SBR
Turn Type	Split	NA	Perm	Split	NA	Perm	Prot	NA	Perm	Prot	NA	Perm
Protected Phases	2	2		6	6		3	8		7	4	
Permitted Phases			2			6			8			4
Detector Phase	2	2	2	6	6	6	3	8	8	7	4	4
Switch Phase												
Minimum Initial (s)	5.0	5.0	5.0	5.0	5.0	5.0	5.0	5.0	5.0	5.0	5.0	5.0
Minimum Split (s)	34.5	34.5	34.5	42.5	42.5	42.5	8.5	46.5	46.5	8.5	39.5	39.5
Total Split (s)	35.0	35.0	35.0	42.5	42.5	42.5	18.0	48.0	48.0	9.5	39.5	39.5
Total Split (%)	25.9%	25.9%	25.9%	31.5%	31.5%	31.5%	13.3%	35.6%	35.6%	7.0%	29.3%	29.3%
Maximum Green (s)	30.5	30.5	30.5	38.0	38.0	38.0	14.5	43.5	43.5	6.0	35.0	35.0
Yellow Time (s)	3.5	3.5	3.5	3.5	3.5	3.5	3.0	3.5	3.5	3.0	3.5	3.5
All-Red Time (s)	1.0	1.0	1.0	1.0	1.0	1.0	0.5	1.0	1.0	0.5	1.0	1.0
Lost Time Adjust (s)	0.0	0.0	0.0		0.0	0.0	0.0	0.0	0.0	0.0	0.0	0.0
Total Lost Time (s)	4.5	4.5	4.5		4.5	4.5	3.5	4.5	4.5	3.5	4.5	4.5
Lead/Lag	Lead	Lead	Lead	Lag	Lag	Lag	Lead	Lag	Lag	Lead	Lag	Lag
Lead-Lag Optimize?	Yes	Yes	Yes	Yes	Yes	Yes	Yes	Yes	Yes	Yes	Yes	Yes
Vehicle Extension (s)	3.0	3.0	3.0	3.0	3.0	3.0	3.0	3.0	3.0	3.0	3.0	3.0
Recall Mode	None	None	None	None	None	None	None	None	None	None	None	None
Walk Time (s)	7.0	7.0	7.0	7.0	7.0	7.0		7.0	7.0		7.0	7.0
Flash Don't Walk (s)	23.0	23.0	23.0	31.0	31.0	31.0		35.0	35.0		28.0	28.0
Pedestrian Calls (#/hr)	0	0	0	0	0	0		0	0		0	0
Act Effct Green (s)	30.5	30.5	30.5		38.0	38.0	14.5	43.5	43.5	6.0	35.0	35.0
Actuated g/C Ratio	0.23	0.23	0.23		0.28	0.28	0.11	0.32	0.32	0.04	0.26	0.26
v/c Ratio	0.82	1.37	1.22		1.02	0.15	3.77	1.02	0.09	1.38	1.22	0.60
Control Delay (s/veh)	67.1	220.3	140.4		92.8	3.4	Error	86.1	2.3	279.8	160.3	33.0
Queue Delay	0.0	0.0	0.0		0.0	0.0	0.0	0.0	0.0	0.0	0.0	0.0
Total Delay (s/veh)	67.1	220.3	140.4		92.8	3.4	Error	86.1	2.3	279.8	160.3	33.0
LOS	E	F	F		F	A	F	F	A	F	F	C
Approach Delay (s/veh)		154.2			81.6			704.6			136.5	
Approach LOS		F			F			F			F	

Intersection Summary

Area Type: Other  
 Cycle Length: 135  
 Actuated Cycle Length: 135  
 Natural Cycle: 145  
 Control Type: Actuated-Uncoordinated  
 Maximum v/c Ratio: 3.77  
 Intersection Signal Delay (s/veh): 306.4  
 Intersection LOS: F  
 Intersection Capacity Utilization 135.8%  
 ICU Level of Service H  
 Analysis Period (min) 15



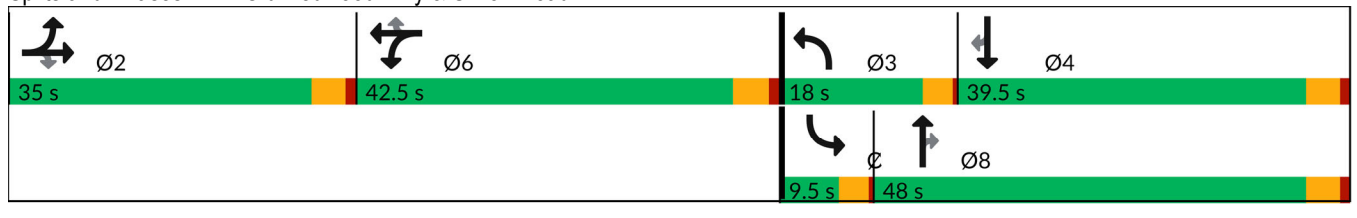



























Splits and Phases: 1: Old Redwood Hwy & Shiloh Road



Lanes, Volumes, Timings  
2: Shiloh Road & Hembree Ln

General Plan 2040 Project Altern. A Conditions

Timing Plan: P.M. Peak

												
Lane Group	EBL	EBT	EBR	WBL	WBT	WBR	NBL	NBT	NBR	SBL	SBT	SBR
Lane Configurations	 	 		 	 		 	 		 	 	 
Traffic Volume (vph)	661	1344	69	110	1146	118	111	21	128	174	11	526
Future Volume (vph)	661	1344	69	110	1146	118	111	21	128	174	11	526
Ideal Flow (vphpl)	1900	1900	1900	1900	1900	1900	1900	1900	1900	1900	1900	1900
Storage Length (ft)	0		0	100		130	0		0	0		0
Storage Lanes	2		0	1		1	1		0	0		1
Taper Length (ft)	25			50			25			25		
Lane Util. Factor	0.97	1.00	1.00	1.00	0.95	0.95	1.00	1.00	1.00	1.00	1.00	1.00
Ped Bike Factor	1.00				1.00							
Frt		0.993			0.986			0.871				0.850
Flt Protected	0.950			0.950			0.950				0.955	
Satd. Flow (prot)	3433	1850	0	1770	3485	0	1770	1622	0	0	1779	1583
Flt Permitted	0.950			0.950			0.950				0.955	
Satd. Flow (perm)	3432	1850	0	1770	3485	0	1770	1622	0	0	1779	1583
Right Turn on Red			Yes			Yes			Yes			Yes
Satd. Flow (RTOR)		5			16			128				61
Link Speed (mph)		40			40			30				35
Link Distance (ft)		302			1789			216				381
Travel Time (s)		5.1			30.5			4.9				7.4
Confl. Peds. (#/hr)	2						2					
Peak Hour Factor	0.94	0.94	1.00	1.00	0.87	0.87	1.00	1.00	1.00	0.95	1.00	0.95
Adj. Flow (vph)	703	1430	69	110	1317	136	111	21	128	183	11	554
Shared Lane Traffic (%)												
Lane Group Flow (vph)	703	1499	0	110	1453	0	111	149	0	0	194	554
Enter Blocked Intersection	No	No	No	No	No	No	No	No	No	No	No	No
Lane Alignment	Left	Left	Right	Left	Left	Right	Left	Left	Right	Left	Left	Right
Median Width(ft)		24			24			12				12
Link Offset(ft)		0			0			0				0
Crosswalk Width(ft)		16			16			16				16
Two way Left Turn Lane												
Headway Factor	1.00	1.00	1.00	1.00	1.00	1.00	1.00	1.00	1.00	1.00	1.00	1.00
Turning Speed (mph)	15		60	60		9	60		60	15		9
Number of Detectors	1	2		1	2		1	2		1	2	1
Detector Template	Left	Thru		Left	Thru		Left	Thru		Left	Thru	Right
Leading Detector (ft)	20	100		20	100		20	100		20	100	20
Trailing Detector (ft)	0	0		0	0		0	0		0	0	0
Detector 1 Position(ft)	0	0		0	0		0	0		0	0	0
Detector 1 Size(ft)	20	6		20	6		20	6		20	6	20
Detector 1 Type	Cl+Ex	Cl+Ex		Cl+Ex	Cl+Ex		Cl+Ex	Cl+Ex		Cl+Ex	Cl+Ex	Cl+Ex
Detector 1 Channel												
Detector 1 Extend (s)	0.0	0.0		0.0	0.0		0.0	0.0		0.0	0.0	0.0
Detector 1 Queue (s)	0.0	0.0		0.0	0.0		0.0	0.0		0.0	0.0	0.0
Detector 1 Delay (s)	0.0	0.0		0.0	0.0		0.0	0.0		0.0	0.0	0.0
Detector 2 Position(ft)		94			94			94				94
Detector 2 Size(ft)		6			6			6				6
Detector 2 Type		Cl+Ex			Cl+Ex			Cl+Ex				Cl+Ex
Detector 2 Channel												
Detector 2 Extend (s)		0.0			0.0			0.0				0.0
Turn Type	Prot	NA		Prot	NA		Split	NA		Split	NA	pt+ov

Lanes, Volumes, Timings  
2: Shiloh Road & Hembree Ln

General Plan 2040 Project Altern. A Conditions

Timing Plan: P.M. Peak

Lane Group	EBL	EBT	EBR	WBL	WBT	WBR	NBL	NBT	NBR	SBL	SBT	SBR
Protected Phases	5	2		1	6		8	8		4	4	4 5
Permitted Phases												
Detector Phase	5	2		1	6		8	8		4	4	4 5
Switch Phase												
Minimum Initial (s)	3.0	5.0		5.0	5.0		5.0	5.0		5.0	5.0	
Minimum Split (s)	7.5	9.5		9.5	43.5		9.5	9.5		9.5	9.5	
Total Split (s)	21.0	57.0		9.5	45.5		9.5	9.5		14.0	14.0	
Total Split (%)	23.3%	63.3%		10.6%	50.6%		10.6%	10.6%		15.6%	15.6%	
Maximum Green (s)	17.0	53.0		5.5	41.5		5.5	5.5		10.0	10.0	
Yellow Time (s)	3.0	3.0		3.0	3.0		3.0	3.0		3.0	3.0	
All-Red Time (s)	1.0	1.0		1.0	1.0		1.0	1.0		1.0	1.0	
Lost Time Adjust (s)	0.0	0.0		0.0	0.0		0.0	0.0		0.0	0.0	
Total Lost Time (s)	4.0	4.0		4.0	4.0		4.0	4.0		4.0	4.0	
Lead/Lag	Lead	Lag		Lead	Lag							
Lead-Lag Optimize?	Yes	Yes		Yes	Yes							
Vehicle Extension (s)	3.0	3.0		3.0	3.0		3.0	3.0		3.0	3.0	
Recall Mode	None	None		None	None		None	None		None	None	
Walk Time (s)					7.0							
Flash Don't Walk (s)					32.0							
Pedestrian Calls (#/hr)					1							
Act Effct Green (s)	17.0	53.0		5.5	41.5		5.5	5.5		10.0	27.0	
Actuated g/C Ratio	0.19	0.59		0.06	0.46		0.06	0.06		0.11	0.30	
v/c Ratio	1.08	1.37		1.02	0.90		1.03	0.68		0.98	1.07	
Control Delay (s/veh)	96.8	195.8		136.9	31.3		139.2	27.8		103.0	85.5	
Queue Delay	0.0	0.1		0.0	0.0		0.0	0.0		0.0	0.0	
Total Delay (s/veh)	96.8	195.9		136.9	31.3		139.2	27.8		103.0	85.5	
LOS	F	F		F	C		F	C		F	F	
Approach Delay (s/veh)		164.2			38.7			75.4			90.0	
Approach LOS		F			D			E			F	

Intersection Summary

Area Type:	Other
Cycle Length:	90
Actuated Cycle Length:	90
Natural Cycle:	140
Control Type:	Actuated-Uncoordinated
Maximum v/c Ratio:	1.37
Intersection Signal Delay (s/veh):	106.7
Intersection LOS:	F
Intersection Capacity Utilization:	113.6%
ICU Level of Service:	H
Analysis Period (min):	15

Splits and Phases: 2: Shiloh Road & Hembree Ln



Lanes, Volumes, Timings  
3: US 101 NB Off-Ramp & Shiloh Road

General Plan 2040 Project Altern. A Conditions

Timing Plan: P.M. Peak

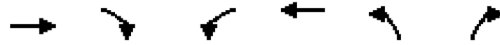

Lane Group	EBT	EBR	WBL	WBT	NBL	NBR
Lane Configurations	↑↑			↑	↘	↗↗
Traffic Volume (vph)	974	0	0	1119	694	1057
Future Volume (vph)	974	0	0	1119	694	1057
Ideal Flow (vphpl)	1900	1900	1900	1900	1900	1900
Storage Length (ft)		0	0		0	265
Storage Lanes		0	0		1	2
Taper Length (ft)			25		25	
Lane Util. Factor	0.95	1.00	1.00	1.00	1.00	0.88
Frt						0.850
Flt Protected					0.950	
Satd. Flow (prot)	3539	0	0	1863	1770	2787
Flt Permitted					0.950	
Satd. Flow (perm)	3539	0	0	1863	1770	2787
Right Turn on Red		Yes				Yes
Satd. Flow (RTOR)						93
Link Speed (mph)	40			40	30	
Link Distance (ft)	186			371	769	
Travel Time (s)	3.2			6.3	17.5	
Peak Hour Factor	0.94	0.94	0.97	0.97	0.90	0.90
Adj. Flow (vph)	1036	0	0	1154	771	1174
Shared Lane Traffic (%)						
Lane Group Flow (vph)	1036	0	0	1154	771	1174
Enter Blocked Intersection	No	No	No	No	No	No
Lane Alignment	Left	Right	Left	Left	Left	Right
Median Width(ft)	0			0	12	
Link Offset(ft)	0			0	0	
Crosswalk Width(ft)	16			16	16	
Two way Left Turn Lane						
Headway Factor	1.00	1.00	1.00	1.00	1.00	1.00
Turning Speed (mph)		9	15		15	9
Number of Detectors	2			2	1	1
Detector Template	Thru			Thru	Left	Right
Leading Detector (ft)	100			100	20	20
Trailing Detector (ft)	0			0	0	0
Detector 1 Position(ft)	0			0	0	0
Detector 1 Size(ft)	6			6	20	20
Detector 1 Type	Cl+Ex			Cl+Ex	Cl+Ex	Cl+Ex
Detector 1 Channel						
Detector 1 Extend (s)	0.0			0.0	0.0	0.0
Detector 1 Queue (s)	0.0			0.0	0.0	0.0
Detector 1 Delay (s)	0.0			0.0	0.0	0.0
Detector 2 Position(ft)	94			94		
Detector 2 Size(ft)	6			6		
Detector 2 Type	Cl+Ex			Cl+Ex		
Detector 2 Channel						
Detector 2 Extend (s)	0.0			0.0		
Turn Type	NA			NA	Prot	Perm
Protected Phases	2			6	8	
Permitted Phases						8

Lanes, Volumes, Timings  
 3: US 101 NB Off-Ramp & Shiloh Road



Lane Group	EBT	EBR	WBL	WBT	NBL	NBR
Detector Phase	2			6	8	8
Switch Phase						
Minimum Initial (s)	5.0			5.0	5.0	5.0
Minimum Split (s)	9.0			9.0	9.0	9.0
Total Split (s)	37.0			37.0	35.0	35.0
Total Split (%)	51.4%			51.4%	48.6%	48.6%
Maximum Green (s)	33.0			33.0	31.0	31.0
Yellow Time (s)	3.0			3.0	3.0	3.0
All-Red Time (s)	1.0			1.0	1.0	1.0
Lost Time Adjust (s)	0.0			0.0	0.0	0.0
Total Lost Time (s)	4.0			4.0	4.0	4.0
Lead/Lag						
Lead-Lag Optimize?						
Vehicle Extension (s)	3.0			3.0	3.0	3.0
Recall Mode	None			None	None	None
Act Effect Green (s)	33.0			33.0	31.0	31.0
Actuated g/C Ratio	0.46			0.46	0.43	0.43
v/c Ratio	0.64			1.35	1.01	0.94
Control Delay (s/veh)	17.2			188.7	58.8	34.0
Queue Delay	0.0			0.0	0.0	0.0
Total Delay (s/veh)	17.2			188.7	58.8	34.0
LOS	B			F	E	C
Approach Delay (s/veh)	17.2			188.7	43.8	
Approach LOS	B			F	D	

Intersection Summary

Area Type:	Other
Cycle Length:	72
Actuated Cycle Length:	72
Natural Cycle:	120
Control Type:	Actuated-Uncoordinated
Maximum v/c Ratio:	1.35
Intersection Signal Delay (s/veh):	77.6
Intersection LOS:	E
Intersection Capacity Utilization:	181.8%
ICU Level of Service:	H
Analysis Period (min):	15

Splits and Phases: 3: US 101 NB Off-Ramp & Shiloh Road

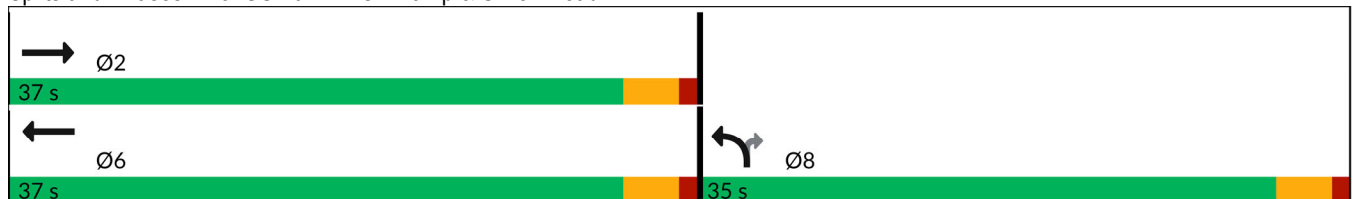

Lanes, Volumes, Timings  
4: Shiloh Road & US 101 SB Off-Ramp

General Plan 2040 Project Altern. A Conditions

Timing Plan: P.M. Peak

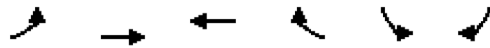

Lane Group	EBL	EBT	WBT	WBR	SBL	SBR
Lane Configurations		↑	↑		↓	↓
Traffic Volume (vph)	0	672	1084	0	500	94
Future Volume (vph)	0	672	1084	0	500	94
Ideal Flow (vphp)	1900	1900	1900	1900	1900	1900
Storage Length (ft)	0			0	0	275
Storage Lanes	0			0	1	1
Taper Length (ft)	25				25	
Lane Util. Factor	1.00	1.00	1.00	1.00	1.00	1.00
Ped Bike Factor						0.98
Frt						0.850
Flt Protected					0.950	
Satd. Flow (prot)	0	1863	1863	0	1770	1583
Flt Permitted					0.950	
Satd. Flow (perm)	0	1863	1863	0	1770	1548
Right Turn on Red				Yes		Yes
Satd. Flow (RTOR)						101
Link Speed (mph)		40	40		30	
Link Distance (ft)		225	306		486	
Travel Time (s)		3.8	5.2		11.0	
Confl. Peds. (#/hr)						1
Peak Hour Factor	0.89	0.89	0.96	0.96	0.93	0.93
Adj. Flow (vph)	0	755	1129	0	538	101
Shared Lane Traffic (%)						
Lane Group Flow (vph)	0	755	1129	0	538	101
Enter Blocked Intersection	No	No	No	No	No	No
Lane Alignment	Left	Left	Left	Right	Left	Right
Median Width(ft)		4	0		12	
Link Offset(ft)		0	0		0	
Crosswalk Width(ft)		16	16		16	
Two way Left Turn Lane						
Headway Factor	1.00	1.00	1.00	1.00	1.00	1.00
Turning Speed (mph)	15			9	15	9
Number of Detectors		2	2		1	1
Detector Template		Thru	Thru		Left	Right
Leading Detector (ft)		100	100		20	20
Trailing Detector (ft)		0	0		0	0
Detector 1 Position(ft)		0	0		0	0
Detector 1 Size(ft)		6	6		20	20
Detector 1 Type		Cl+Ex	Cl+Ex		Cl+Ex	Cl+Ex
Detector 1 Channel						
Detector 1 Extend (s)		0.0	0.0		0.0	0.0
Detector 1 Queue (s)		0.0	0.0		0.0	0.0
Detector 1 Delay (s)		0.0	0.0		0.0	0.0
Detector 2 Position(ft)		94	94			
Detector 2 Size(ft)		6	6			
Detector 2 Type		Cl+Ex	Cl+Ex			
Detector 2 Channel						
Detector 2 Extend (s)		0.0	0.0			
Turn Type		NA	NA		Perm	Perm

Lanes, Volumes, Timings  
4: Shiloh Road & US 101 SB Off-Ramp

General Plan 2040 Project Altern. A Conditions  
Timing Plan: P.M. Peak



Lane Group	EBL	EBT	WBT	WBR	SBL	SBR
Protected Phases		2	6			
Permitted Phases					4	4
Detector Phase		2	6		4	4
Switch Phase						
Minimum Initial (s)		5.0	5.0		5.0	5.0
Minimum Split (s)		9.0	38.0		9.0	9.0
Total Split (s)		69.0	69.0		21.0	21.0
Total Split (%)		76.7%	76.7%		23.3%	23.3%
Maximum Green (s)		65.0	65.0		17.0	17.0
Yellow Time (s)		3.0	3.0		3.0	3.0
All-Red Time (s)		1.0	1.0		1.0	1.0
Lost Time Adjust (s)		0.0	0.0		0.0	0.0
Total Lost Time (s)		4.0	4.0		4.0	4.0
Lead/Lag						
Lead-Lag Optimize?						
Vehicle Extension (s)		3.0	3.0		3.0	3.0
Recall Mode		None	None		None	None
Walk Time (s)			7.0			
Flash Don't Walk (s)			27.0			
Pedestrian Calls (#/hr)			0			
Act Effct Green (s)		50.9	50.9		17.5	17.5
Actuated g/C Ratio		0.66	0.66		0.23	0.23
v/c Ratio		0.61	0.91		1.33	0.23
Control Delay (s/veh)		9.2	22.9		195.0	8.6
Queue Delay		0.0	0.0		0.0	0.0
Total Delay (s/veh)		9.2	22.9		195.0	8.6
LOS		A	C		F	A
Approach Delay (s/veh)		9.2	22.9		165.5	
Approach LOS		A	C		F	

Intersection Summary

Area Type:	Other
Cycle Length:	90
Actuated Cycle Length:	76.7
Natural Cycle:	90
Control Type:	Actuated-Uncoordinated
Maximum v/c Ratio:	1.33
Intersection Signal Delay (s/veh):	54.9
Intersection LOS:	D
Intersection Capacity Utilization:	176.9%
ICU Level of Service:	H
Analysis Period (min):	15

Splits and Phases: 4: Shiloh Road & US 101 SB Off-Ramp

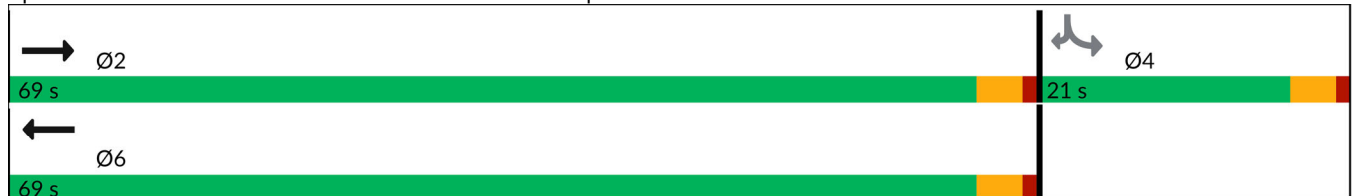

Lanes, Volumes, Timings  
5: Caletti Ave & Shiloh Road

General Plan 2040 Project Altern. A Conditions

Timing Plan: P.M. Peak



















	→	↘	↙	←	↖	↗
Lane Group	EBT	EBR	WBL	WBT	NBL	NBR
Lane Configurations	↑↑		↘	↑	↘	↗
Traffic Volume (vph)	1214	16	105	1143	18	159
Future Volume (vph)	1214	16	105	1143	18	159
Ideal Flow (vphpl)	1900	1900	1900	1900	1900	1900
Storage Length (ft)		0	68		0	0
Storage Lanes		0	1		1	1
Taper Length (ft)			50		25	
Lane Util. Factor	0.95	0.95	1.00	1.00	1.00	1.00
Frt	0.998					0.850
Flt Protected			0.950		0.950	
Satd. Flow (prot)	3532	0	1770	1863	1770	1583
Flt Permitted			0.950		0.950	
Satd. Flow (perm)	3532	0	1770	1863	1770	1583
Link Speed (mph)	40			40	30	
Link Distance (ft)	1081			184	459	
Travel Time (s)	18.4			3.1	10.4	
Peak Hour Factor	0.89	0.89	0.92	0.92	0.89	0.89
Adj. Flow (vph)	1364	18	114	1242	20	179
Shared Lane Traffic (%)						
Lane Group Flow (vph)	1382	0	114	1242	20	179
Enter Blocked Intersection	No	No	No	No	No	No
Lane Alignment	Left	Right	Left	Left	Left	Right
Median Width(ft)	12			12	12	
Link Offset(ft)	0			0	0	
Crosswalk Width(ft)	16			16	16	
Two way Left Turn Lane						
Headway Factor	1.00	1.00	1.00	1.00	1.00	1.00
Turning Speed (mph)		9	15		15	9
Sign Control	Free			Free	Stop	
<b>Intersection Summary</b>						
Area Type:	Other					
Control Type:	Unsignalized					
Intersection Capacity Utilization	70.2%			ICU Level of Service C		
Analysis Period (min)	15					



Lanes, Volumes, Timings  
6: Conde Lane & Shiloh Road

General Plan 2040 Project Altern. A Conditions

Timing Plan: P.M. Peak

												
Lane Group	EBL	EBT	EBR	WBL	WBT	WBR	NBL	NBT	NBR	SBL	SBT	SBR
Lane Configurations												
Traffic Volume (vph)	77	737	0	9	747	372	4	2	16	387	4	65
Future Volume (vph)	77	737	0	9	747	372	4	2	16	387	4	65
Ideal Flow (vphpl)	1900	1900	1900	1900	1900	1900	1900	1900	1900	1900	1900	1900
Storage Length (ft)	90		0	127		0	0		0	0		40
Storage Lanes	1		0	1		0	0		0	0		1
Taper Length (ft)	70			40			25			25		
Lane Util. Factor	1.00	0.95	0.95	1.00	0.95	0.95	1.00	1.00	1.00	1.00	1.00	1.00
Ped Bike Factor	1.00				0.99							
Frt					0.950			0.901				0.850
Flt Protected	0.950			0.950				0.991			0.953	
Satd. Flow (prot)	1770	3539	0	1770	3338	0	0	1663	0	0	1775	1583
Flt Permitted	0.950			0.950				0.991			0.953	
Satd. Flow (perm)	1768	3539	0	1770	3338	0	0	1663	0	0	1775	1583
Right Turn on Red			Yes			Yes			Yes			No
Satd. Flow (RTOR)					90			25				
Link Speed (mph)		40			40			30				35
Link Distance (ft)		815			1081			418				522
Travel Time (s)		13.9			18.4			9.5				10.2
Confl. Peds. (#/hr)	1						1					
Peak Hour Factor	0.88	0.88	0.88	0.80	0.80	0.80	0.63	0.63	0.63	0.88	0.88	0.88
Adj. Flow (vph)	88	838	0	11	934	465	6	3	25	440	5	74
Shared Lane Traffic (%)												
Lane Group Flow (vph)	88	838	0	11	1399	0	0	34	0	0	445	74
Enter Blocked Intersection	No	No	No	No	No	No	No	No	No	No	No	No
Lane Alignment	Left	Left	Right	Left	Left	Right	Left	Left	Right	Left	Left	Right
Median Width(ft)		12			12			0				0
Link Offset(ft)		0			0			0				0
Crosswalk Width(ft)		16			16			16				16
Two way Left Turn Lane												
Headway Factor	1.00	1.00	1.00	1.00	1.00	1.00	1.00	1.00	1.00	1.00	1.00	1.00
Turning Speed (mph)	15		9	15		9	15		9	15		9
Number of Detectors	1	2		1	2		1	2		1	1	1
Detector Template	Left	Thru		Left	Thru		Left	Thru		Left	Thru	Right
Leading Detector (ft)	20	100		20	100		20	100		20	30	20
Trailing Detector (ft)	0	0		0	0		0	0		0	0	0
Detector 1 Position(ft)	0	0		0	0		0	0		0	0	0
Detector 1 Size(ft)	20	6		20	6		20	6		20	30	20
Detector 1 Type	Cl+Ex	Cl+Ex		Cl+Ex	Cl+Ex		Cl+Ex	Cl+Ex		Cl+Ex	Cl+Ex	Cl+Ex
Detector 1 Channel												
Detector 1 Extend (s)	0.0	0.0		0.0	0.0		0.0	0.0		0.0	0.0	0.0
Detector 1 Queue (s)	0.0	0.0		0.0	0.0		0.0	0.0		0.0	0.0	0.0
Detector 1 Delay (s)	0.0	0.0		0.0	0.0		0.0	0.0		0.0	0.0	0.0
Detector 2 Position(ft)		94			94			94				
Detector 2 Size(ft)		6			6			6				
Detector 2 Type		Cl+Ex			Cl+Ex			Cl+Ex				
Detector 2 Channel												
Detector 2 Extend (s)		0.0			0.0			0.0				
Turn Type	Prot	NA		Prot	NA		Split	NA		Split	NA	custom

Lanes, Volumes, Timings  
6: Conde Lane & Shiloh Road

General Plan 2040 Project Altern. A Conditions

Timing Plan: P.M. Peak

Lane Group	EBL	EBT	EBR	WBL	WBT	WBR	NBL	NBT	NBR	SBL	SBT	SBR
Protected Phases	5	2		1	6		7	7		4	4	
Permitted Phases												6
Detector Phase	5	2		1	6		7	7		4	4	6
Switch Phase												
Minimum Initial (s)	8.0	8.0		8.0	8.0		10.0	10.0		11.0	11.0	8.0
Minimum Split (s)	12.0	46.0		12.0	12.0		37.0	37.0		15.0	15.0	12.0
Total Split (s)	13.0	46.0		12.0	45.0		37.0	37.0		15.0	15.0	45.0
Total Split (%)	11.8%	41.8%		10.9%	40.9%		33.6%	33.6%		13.6%	13.6%	40.9%
Maximum Green (s)	9.0	42.0		8.0	41.0		33.0	33.0		11.0	11.0	41.0
Yellow Time (s)	3.0	3.0		3.0	3.0		3.0	3.0		3.0	3.0	3.0
All-Red Time (s)	1.0	1.0		1.0	1.0		1.0	1.0		1.0	1.0	1.0
Lost Time Adjust (s)	0.0	0.0		0.0	0.0		0.0	0.0		0.0	0.0	0.0
Total Lost Time (s)	4.0	4.0		4.0	4.0		4.0	4.0		4.0	4.0	4.0
Lead/Lag	Lead	Lag		Lead	Lag							Lag
Lead-Lag Optimize?	Yes	Yes		Yes	Yes							Yes
Vehicle Extension (s)	3.0	3.0		3.0	3.0		3.0	3.0		3.0	3.0	3.0
Recall Mode	None	None		None	None		None	None		None	None	None
Walk Time (s)		7.0					7.0	7.0				
Flash Don't Walk (s)		35.0					26.0	26.0				
Pedestrian Calls (#/hr)		0					0	0				
Act Effct Green (s)	8.7	49.4		8.2	41.9		10.2	10.2		11.2	11.2	41.9
Actuated g/C Ratio	0.11	0.63		0.10	0.53		0.13	0.13		0.14	0.14	0.53
v/c Ratio	0.45	0.38		0.06	0.77		0.14	0.14		1.75	1.75	0.09
Control Delay (s/veh)	44.0	9.5		37.1	19.7		19.5	19.5		381.4	381.4	12.6
Queue Delay	0.0	0.0		0.0	0.0		0.0	0.0		0.0	0.0	0.0
Total Delay (s/veh)	44.0	9.5		37.1	19.7		19.5	19.5		381.4	381.4	12.6
LOS	D	A		D	B		B	B		F	F	B
Approach Delay (s/veh)		12.7			19.8		19.5	19.5		328.8	328.8	
Approach LOS		B			B		B	B		F	F	

Intersection Summary

Area Type:	Other
Cycle Length:	110
Actuated Cycle Length:	78.6
Natural Cycle:	150
Control Type:	Actuated-Uncoordinated
Maximum v/c Ratio:	1.75
Intersection Signal Delay (s/veh):	73.1
Intersection LOS:	E
Intersection Capacity Utilization:	77.6%
ICU Level of Service:	D
Analysis Period (min):	15



















Splits and Phases: 6: Conde Lane & Shiloh Road



Lanes, Volumes, Timings  
7: Driveway 1/Gridley Drive & Shiloh Road

General Plan 2040 Project Altern. A Conditions

Timing Plan: P.M. Peak





















												
Lane Group	EBL	EBT	EBR	WBL	WBT	WBR	NBL	NBT	NBR	SBL	SBT	SBR
Lane Configurations												
Traffic Volume (vph)	25	521	121	0	443	0	84	0	0	0	0	21
Future Volume (vph)	25	521	121	0	443	0	84	0	0	0	0	21
Ideal Flow (vphpl)	1900	1900	1900	1900	1900	1900	1900	1900	1900	1900	1900	1900
Storage Length (ft)	0		150	0		0	0		0	0		0
Storage Lanes	0		1	0		0	1		0	0		0
Taper Length (ft)	25			25			25			25		
Lane Util. Factor	1.00	1.00	1.00	1.00	1.00	1.00	1.00	1.00	1.00	1.00	1.00	1.00
Ped Bike Factor												
Frt			0.850								0.865	
Flt Protected		0.998					0.950					
Satd. Flow (prot)	0	1859	1583	0	1863	0	1770	1863	0	0	1611	0
Flt Permitted		0.998					0.950					
Satd. Flow (perm)	0	1859	1583	0	1863	0	1770	1863	0	0	1611	0
Link Speed (mph)		40			40			30			30	
Link Distance (ft)		608			2146			248			715	
Travel Time (s)		10.4			36.6			5.6			16.3	
Confl. Peds. (#/hr)	1											
Confl. Bikes (#/hr)			1									
Peak Hour Factor	0.94	0.94	0.94	0.69	0.69	0.69	1.00	1.00	1.00	0.58	0.58	0.58
Adj. Flow (vph)	27	554	129	0	642	0	84	0	0	0	0	36
Shared Lane Traffic (%)												
Lane Group Flow (vph)	0	581	129	0	642	0	84	0	0	0	36	0
Enter Blocked Intersection	No	No	No	No	No	No	No	No	No	No	No	No
Lane Alignment	Left	Left	Right	Left	Left	Right	Left	Left	Right	Left	Left	Right
Median Width(ft)		0			0			12			12	
Link Offset(ft)		0			0			0			0	
Crosswalk Width(ft)		16			16			16			16	
Two way Left Turn Lane												
Headway Factor	1.00	1.00	1.00	1.00	1.00	1.00	1.00	1.00	1.00	1.00	1.00	1.00
Turning Speed (mph)	15		9	15		9	15		9	15		9
Sign Control		Free			Free			Stop			Stop	

Intersection Summary	
Area Type:	Other
Control Type:	Unsignalized
Intersection Capacity Utilization	65.7%
Analysis Period (min)	15
	ICU Level of Service C

Lanes, Volumes, Timings  
8: Old Redwood Hwy & Driveway 2

General Plan 2040 Project Altern. A Conditions

Timing Plan: P.M. Peak

												
Lane Group	EBL	EBT	EBR	WBL	WBT	WBR	NBL	NBT	NBR	SBL	SBT	SBR
Lane Configurations												
Traffic Volume (vph)	4	0	0	49	0	79	0	1195	71	114	1152	0
Future Volume (vph)	4	0	0	49	0	79	0	1195	71	114	1152	0
Ideal Flow (vphp)	1900	1900	1900	1900	1900	1900	1900	1900	1900	1900	1900	1900
Storage Length (ft)	0		0	0		0	0		100	50		0
Storage Lanes	0		0	1		0	0		1	1		0
Taper Length (ft)	25			25			25			25		
Lane Util. Factor	1.00	1.00	1.00	1.00	1.00	1.00	1.00	1.00	1.00	1.00	1.00	1.00
Ped Bike Factor												
Frt					0.850				0.850			
Flt Protected		0.950		0.950						0.950		
Satd. Flow (prot)	0	1770	0	1770	1583	0	0	1863	1583	1770	1863	0
Flt Permitted		0.950		0.950						0.950		
Satd. Flow (perm)	0	1770	0	1770	1583	0	0	1863	1583	1770	1863	0
Link Speed (mph)		30			30			45			45	
Link Distance (ft)		98			385			520			748	
Travel Time (s)		2.2			8.8			7.9			11.3	
Confl. Bikes (#/hr)									3			5
Peak Hour Factor	0.38	0.38	0.38	1.00	1.00	1.00	0.91	0.91	0.91	0.94	0.94	0.94
Adj. Flow (vph)	11	0	0	49	0	79	0	1313	78	121	1226	0
Shared Lane Traffic (%)												
Lane Group Flow (vph)	0	11	0	49	79	0	0	1313	78	121	1226	0
Enter Blocked Intersection	No	No	No	No	No	No	No	No	No	No	No	No
Lane Alignment	Left	Left	Right	Left	Left	Right	Left	Left	Right	Left	Left	Right
Median Width(ft)		12			12			12			12	
Link Offset(ft)		0			0			0			0	
Crosswalk Width(ft)		16			16			16			16	
Two way Left Turn Lane												
Headway Factor	1.00	1.00	1.00	1.00	1.00	1.00	1.00	1.00	1.00	1.00	1.00	1.00
Turning Speed (mph)	15		9	15		9	15		9	15		9
Sign Control		Stop			Stop			Free			Free	
<b>Intersection Summary</b>												
Area Type:	Other											
Control Type:	Unsignalized											
Intersection Capacity Utilization	106.3%						ICU Level of Service G					
Analysis Period (min)	15											

Lanes, Volumes, Timings  
9: Driveway 3 & Shiloh Road

General Plan 2040 Project Altern. A Conditions

Timing Plan: P.M. Peak

	→	↘	↙	←	↖	↗
Lane Group	EBT	EBR	WBL	WBT	NBL	NBR
Lane Configurations	↑	↗		↖	↘	↗
Traffic Volume (vph)	120	369	35	164	258	25
Future Volume (vph)	120	369	35	164	258	25
Ideal Flow (vphpl)	1900	1900	1900	1900	1900	1900
Storage Length (ft)		200	0		0	0
Storage Lanes		1	0		1	1
Taper Length (ft)			25		25	
Lane Util. Factor	1.00	1.00	1.00	1.00	1.00	1.00
Frt		0.850				0.850
Flt Protected				0.991	0.950	
Satd. Flow (prot)	1863	1583	0	1846	1770	1583
Flt Permitted				0.991	0.950	
Satd. Flow (perm)	1863	1583	0	1846	1770	1583
Link Speed (mph)	40			40	30	
Link Distance (ft)	2146			134	402	
Travel Time (s)	36.6			2.3	9.1	
Peak Hour Factor	0.92	0.92	0.68	0.68	1.00	1.00
Adj. Flow (vph)	130	401	51	241	258	25
Shared Lane Traffic (%)						
Lane Group Flow (vph)	130	401	0	292	258	25
Enter Blocked Intersection	No	No	No	No	No	No
Lane Alignment	Left	Right	Left	Left	Left	Right
Median Width(ft)	0			0	12	
Link Offset(ft)	0			0	0	
Crosswalk Width(ft)	16			16	16	
Two way Left Turn Lane						
Headway Factor	1.00	1.00	1.00	1.00	1.00	1.00
Turning Speed (mph)		9	15		15	9
Sign Control	Free			Free	Stop	

Intersection Summary

Area Type:	Other
Control Type:	Unsignalized
Intersection Capacity Utilization	40.1%
Analysis Period (min)	15
	ICU Level of Service A

Lanes, Volumes, Timings

General Plan 2040 Project Altern. A Conditions

10: US 101 NB Off Ramp/Lakewood Drive & Old Redwood Highway

Timing Plan: P.M. Peak



Lane Group	EBL	EBT	EBR	WBL	WBT	WBR	NBL	NBT	NBR	SBL	SBT	SBR
Lane Configurations												
Traffic Volume (vph)	309	743	0	0	764	270	528	539	303	386	0	618
Future Volume (vph)	309	743	0	0	764	270	528	539	303	386	0	618
Ideal Flow (vphpl)	1900	1900	1900	1900	1900	1900	1900	1900	1900	1900	1900	1900
Storage Length (ft)	155		0	0		0	270		150	120		0
Storage Lanes	1		0	0		0	1		1	1		1
Taper Length (ft)	50			25			165			75		
Lane Util. Factor	0.97	1.00	1.00	1.00	0.95	0.95	0.91	0.91	0.95	0.97	1.00	1.00
Ped Bike Factor	1.00				0.99			0.99		1.00		
Fr <sub>t</sub>					0.961			0.950				0.850
Fl <sub>t</sub> Protected	0.950						0.950	0.996		0.950		
Satd. Flow (prot)	3433	1863	0	0	3382	0	1610	3187	0	3433	0	1583
Fl <sub>t</sub> Permitted	0.950						0.950	0.996		0.950		
Satd. Flow (perm)	3429	1863	0	0	3382	0	1610	3187	0	3422	0	1583
Right Turn on Red			Yes			Yes			Yes			Yes
Satd. Flow (RTOR)					57			72				243
Link Speed (mph)		35			35			30				30
Link Distance (ft)		226			617			716				478
Travel Time (s)		4.4			12.0			16.3				10.9
Confl. Peds. (#/hr)	3		1	1		3			8	8		
Confl. Bikes (#/hr)			2			9						
Peak Hour Factor	0.87	0.87	0.87	0.91	0.91	0.91	0.92	0.92	0.92	0.96	0.96	0.96
Adj. Flow (vph)	355	854	0	0	840	297	574	586	329	402	0	644
Shared Lane Traffic (%)							13%					
Lane Group Flow (vph)	355	854	0	0	1137	0	499	990	0	402	0	644
Enter Blocked Intersection	No	No	No	No	No	No	No	No	No	No	No	No
Lane Alignment	Left	Left	Right	Left	Left	Right	Left	Left	Right	Left	Left	Right
Median Width(ft)		24			24			24				24
Link Offset(ft)		0			0			0				0
Crosswalk Width(ft)		16			16			16				16
Two way Left Turn Lane												
Headway Factor	1.00	1.00	1.00	1.00	1.00	1.00	1.00	1.00	1.00	1.00	1.00	1.00
Turning Speed (mph)	15		9	15		9	15		9	15		9
Number of Detectors	1	2			2		1	2		1		1
Detector Template	Left	Thru			Thru		Left	Thru		Left		Right
Leading Detector (ft)	20	100			100		20	100		20		20
Trailing Detector (ft)	0	0			0		0	0		0		0
Detector 1 Position(ft)	0	0			0		0	0		0		0
Detector 1 Size(ft)	20	6			6		20	6		20		20
Detector 1 Type	Cl+Ex	Cl+Ex			Cl+Ex		Cl+Ex	Cl+Ex		Cl+Ex		Cl+Ex
Detector 1 Channel												
Detector 1 Extend (s)	0.0	0.0			0.0		0.0	0.0		0.0		0.0
Detector 1 Queue (s)	0.0	0.0			0.0		0.0	0.0		0.0		0.0
Detector 1 Delay (s)	0.0	0.0			0.0		0.0	0.0		0.0		0.0
Detector 2 Position(ft)		94			94			94				
Detector 2 Size(ft)		6			6			6				
Detector 2 Type		Cl+Ex			Cl+Ex			Cl+Ex				
Detector 2 Channel												
Detector 2 Extend (s)		0.0			0.0			0.0				

Lanes, Volumes, Timings

General Plan 2040 Project Altern. A Conditions

10: US 101 NB Off Ramp/Lakewood Drive & Old Redwood Highway

Timing Plan: P.M. Peak



Lane Group	EBL	EBT	EBR	WBL	WBT	WBR	NBL	NBT	NBR	SBL	SBT	SBR
Turn Type	Prot	NA			NA		Split	NA		Prot		pm+ov
Protected Phases	5	2			6		8	8		7		5
Permitted Phases												5 8
Detector Phase	5	2			6		8	8		7		5
Switch Phase												
Minimum Initial (s)	7.0	10.0			10.0		10.0	10.0		7.0		7.0
Minimum Split (s)	11.0	32.1			32.1		33.7	33.7		11.0		11.0
Total Split (s)	13.0	45.3			32.3		33.7	33.7		11.0		13.0
Total Split (%)	14.4%	50.3%			35.9%		37.4%	37.4%		12.2%		14.4%
Maximum Green (s)	9.0	40.2			27.2		29.0	29.0		7.0		9.0
Yellow Time (s)	3.0	4.1			4.1		3.7	3.7		3.0		3.0
All-Red Time (s)	1.0	1.0			1.0		1.0	1.0		1.0		1.0
Lost Time Adjust (s)	0.0	0.0			0.0		0.0	0.0		0.0		0.0
Total Lost Time (s)	4.0	5.1			5.1		4.7	4.7		4.0		4.0
Lead/Lag	Lead				Lag		Lag	Lag		Lead		Lead
Lead-Lag Optimize?	Yes				Yes		Yes	Yes		Yes		Yes
Vehicle Extension (s)	3.0	3.0			3.0		3.0	3.0		3.0		3.0
Recall Mode	None	Max			Max		None	None		None		None
Walk Time (s)		7.0			7.0		7.0	7.0				
Flash Don't Walk (s)		20.0			17.0		22.0	22.0				
Pedestrian Calls (#/hr)		0			0		0	0				
Act Effct Green (s)	9.0	40.2			27.2		29.0	29.0		7.0		42.7
Actuated g/C Ratio	0.10	0.45			0.30		0.32	0.32		0.08		0.47
v/c Ratio	1.03	1.03			1.07		0.96	0.92		1.51		0.73
Control Delay (s/veh)	99.4	64.7			79.2		63.3	42.2		277.9		17.3
Queue Delay	0.0	0.0			0.0		0.0	0.0		0.0		0.0
Total Delay (s/veh)	99.4	64.7			79.2		63.3	42.2		277.9		17.3
LOS	F	E			E		E	D		F		B
Approach Delay (s/veh)		74.9			79.2			49.3				117.5
Approach LOS		E			E			D				F

Intersection Summary

Area Type: Other  
 Cycle Length: 90  
 Actuated Cycle Length: 90  
 Natural Cycle: 110  
 Control Type: Actuated-Uncoordinated  
 Maximum v/c Ratio: 1.51  
 Intersection Signal Delay (s/veh): 77.2  
 Intersection LOS: E  
 Intersection Capacity Utilization 106.4%  
 ICU Level of Service G  
 Analysis Period (min) 15

Splits and Phases: 10: US 101 NB Off Ramp/Lakewood Drive & Old Redwood Highway

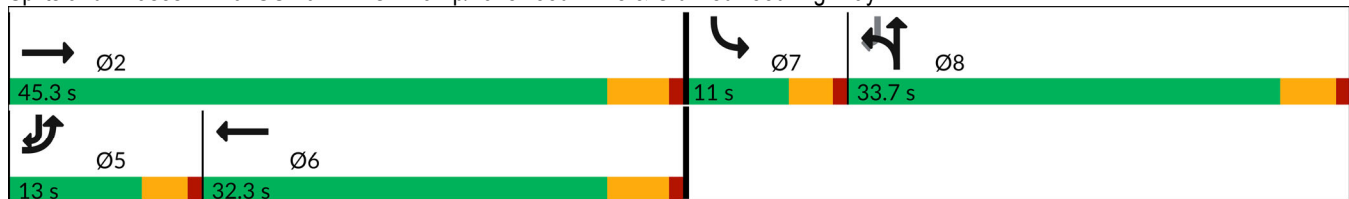

Lanes, Volumes, Timings  
 11: Old Redwood Highway & US 101 NB On Ramp

General Plan 2040 Project Altern. A Conditions

Timing Plan: P.M. Peak

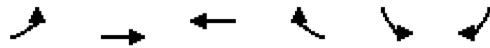

Lane Group	EBL	EBT	WBT	WBR	SBL	SBR
Lane Configurations						
Traffic Volume (vph)	0	1052	1564	297	0	0
Future Volume (vph)	0	1052	1564	297	0	0
Ideal Flow (vphpl)	1900	1900	1900	1900	1900	1900
Storage Length (ft)	245			0	0	0
Storage Lanes	1			0	0	0
Taper Length (ft)	50				25	
Lane Util. Factor	1.00	0.95	0.95	0.95	1.00	1.00
Ped Bike Factor						
Frt			0.976			
Flt Protected						
Satd. Flow (prot)	1863	3539	3454	0	0	0
Flt Permitted						
Satd. Flow (perm)	1863	3539	3454	0	0	0
Link Speed (mph)		35	35		30	
Link Distance (ft)		531	226		299	
Travel Time (s)		10.3	4.4		6.8	
Confl. Peds. (#/hr)	17			17		
Confl. Bikes (#/hr)				8		
Peak Hour Factor	0.85	0.85	0.91	0.91	0.25	0.25
Adj. Flow (vph)	0	1238	1719	326	0	0
Shared Lane Traffic (%)						
Lane Group Flow (vph)	0	1238	2045	0	0	0
Enter Blocked Intersection	No	No	No	No	No	No
Lane Alignment	Left	Left	Left	Right	Left	Right
Median Width(ft)		12	12		0	
Link Offset(ft)		0	0		0	
Crosswalk Width(ft)		16	16		16	
Two way Left Turn Lane						
Headway Factor	1.00	1.00	1.00	1.00	1.00	1.00
Turning Speed (mph)	15			9	15	9
Sign Control		Free	Free		Free	

Intersection Summary

Area Type:	Other
Control Type:	Unsignalized
Intersection Capacity Utilization	84.4%
Analysis Period (min)	15
	ICU Level of Service E



Lanes, Volumes, Timings

General Plan 2040 Project Altern. A Conditions

12: US 101 SB On Ramp/US 101 SB Off Ramp & Old Redwood Highway

Timing Plan: P.M. Peak



Lane Group	EBL	EBT	EBR	WBL	WBT	WBR	NBL	NBT	NBR	SBL	SBT	SBR
Lane Configurations		↑↑	↗	↘	↑↑					↘	↕	
Traffic Volume (vph)	0	612	501	443	1121	0	0	0	0	372	2	221
Future Volume (vph)	0	612	501	443	1121	0	0	0	0	372	2	221
Ideal Flow (vphpl)	1900	1900	1900	1900	1900	1900	1900	1900	1900	1900	1900	1900
Storage Length (ft)	0		0	250		0	0		0	420		0
Storage Lanes	0		1	0		0	0		0	1		0
Taper Length (ft)	25			165			25			75		
Lane Util. Factor	1.00	0.95	1.00	1.00	0.95	1.00	1.00	1.00	1.00	0.95	0.95	1.00
Ped Bike Factor			0.98	1.00								
Frt			0.850								0.884	
Flt Protected				0.950						0.950	0.989	
Satd. Flow (prot)	0	3539	1583	1770	3539	0	0	0	0	1681	1547	0
Flt Permitted				0.950						0.950	0.989	
Satd. Flow (perm)	0	3539	1558	1768	3539	0	0	0	0	1681	1547	0
Right Turn on Red			Yes			Yes			Yes			Yes
Satd. Flow (RTOR)			443								98	
Link Speed (mph)		35			35			30			30	
Link Distance (ft)		423			531			621			831	
Travel Time (s)		8.2			10.3			14.1			18.9	
Confl. Peds. (#/hr)	19		2	2		18						
Confl. Bikes (#/hr)			4			2						
Peak Hour Factor	0.94	0.94	0.94	0.89	0.89	0.89	0.25	0.25	0.25	0.83	0.83	0.83
Adj. Flow (vph)	0	651	533	498	1260	0	0	0	0	448	2	266
Shared Lane Traffic (%)										17%		
Lane Group Flow (vph)	0	651	533	498	1260	0	0	0	0	372	344	0
Enter Blocked Intersection	No	No	No	No	No	No	No	No	No	No	No	No
Lane Alignment	Left	Left	Right	Left	Left	Right	Left	Left	Right	Left	Left	Right
Median Width(ft)		24			24			12			12	
Link Offset(ft)		0			0			0			0	
Crosswalk Width(ft)		16			16			16			16	
Two way Left Turn Lane												
Headway Factor	1.00	1.00	1.00	1.00	1.00	1.00	1.00	1.00	1.00	1.00	1.00	1.00
Turning Speed (mph)	15		9	15		9	15		9	15		9
Number of Detectors		2	1	1	2					1	2	
Detector Template		Thru	Right	Left	Thru					Left	Thru	
Leading Detector (ft)		100	20	20	100					20	100	
Trailing Detector (ft)		0	0	0	0					0	0	
Detector 1 Position(ft)		0	0	0	0					0	0	
Detector 1 Size(ft)		6	20	20	6					20	6	
Detector 1 Type		Cl+Ex	Cl+Ex	Cl+Ex	Cl+Ex					Cl+Ex	Cl+Ex	
Detector 1 Channel												
Detector 1 Extend (s)		0.0	0.0	0.0	0.0					0.0	0.0	
Detector 1 Queue (s)		0.0	0.0	0.0	0.0					0.0	0.0	
Detector 1 Delay (s)		0.0	0.0	0.0	0.0					0.0	0.0	
Detector 2 Position(ft)		94			94							94
Detector 2 Size(ft)		6			6							6
Detector 2 Type		Cl+Ex			Cl+Ex							Cl+Ex
Detector 2 Channel												
Detector 2 Extend (s)		0.0			0.0							0.0

Lanes, Volumes, Timings

General Plan 2040 Project Altern. A Conditions

12: US 101 SB On Ramp/US 101 SB Off Ramp & Old Redwood Highway

Timing Plan: P.M. Peak



Lane Group	EBL	EBT	EBR	WBL	WBT	WBR	NBL	NBT	NBR	SBL	SBT	SBR
Turn Type		NA	Perm	Prot	NA					Perm	NA	
Protected Phases		6		5	2						8	
Permitted Phases			6							8		
Detector Phase		6	6	5	2					8	8	
Switch Phase												
Minimum Initial (s)		10.0	10.0	7.0	10.0					10.0	10.0	
Minimum Split (s)		32.1	32.1	11.0	38.1					14.7	14.7	
Total Split (s)		33.0	33.0	22.0	55.0					15.0	15.0	
Total Split (%)		47.1%	47.1%	31.4%	78.6%					21.4%	21.4%	
Maximum Green (s)		27.9	27.9	18.0	49.9					10.3	10.3	
Yellow Time (s)		4.1	4.1	3.0	4.1					3.7	3.7	
All-Red Time (s)		1.0	1.0	1.0	1.0					1.0	1.0	
Lost Time Adjust (s)		0.0	0.0	0.0	0.0					0.0	0.0	
Total Lost Time (s)		5.1	5.1	4.0	5.1					4.7	4.7	
Lead/Lag		Lag	Lag	Lead								
Lead-Lag Optimize?		Yes	Yes	Yes								
Vehicle Extension (s)		3.0	3.0	3.0	3.0					3.0	3.0	
Recall Mode		Max	Max	None	Max					None	None	
Walk Time (s)		7.0	7.0		7.0							
Flash Don't Walk (s)		20.0	20.0		25.0							
Pedestrian Calls (#/hr)		0	0		0							
Act Effct Green (s)		27.9	27.9	18.0	49.9					10.3	10.3	
Actuated g/C Ratio		0.40	0.40	0.26	0.71					0.15	0.15	
v/c Ratio		0.46	0.60	1.09	0.50					1.51	1.11	
Control Delay (s/veh)		16.8	6.4	98.8	5.3					274.7	107.1	
Queue Delay		0.0	0.0	0.0	0.0					0.0	0.0	
Total Delay (s/veh)		16.8	6.4	98.8	5.3					274.7	107.1	
LOS		B	A	F	A					F	F	
Approach Delay (s/veh)		12.2			31.8						194.2	
Approach LOS		B			C						F	

Intersection Summary

Area Type: Other  
 Cycle Length: 70  
 Actuated Cycle Length: 70  
 Natural Cycle: 90  
 Control Type: Actuated-Uncoordinated  
 Maximum v/c Ratio: 1.51  
 Intersection Signal Delay (s/veh): 57.2  
 Intersection LOS: E  
 Intersection Capacity Utilization 84.4%  
 ICU Level of Service E  
 Analysis Period (min) 15



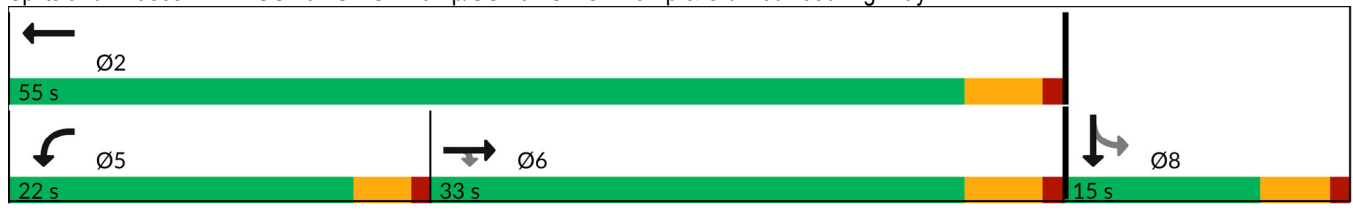



















Splits and Phases: 12: US 101 SB On Ramp/US 101 SB Off Ramp & Old Redwood Highway



Lanes, Volumes, Timings  
1: Old Redwood Hwy & Shiloh Road

General Plan 2040 Project Altern. A Conditions

Timing Plan: Saturday Midday Peak

												
Lane Group	EBL	EBT	EBR	WBL	WBT	WBR	NBL	NBT	NBR	SBL	SBT	SBR
Lane Configurations												
Traffic Volume (vph)	182	506	308	31	522	76	317	352	35	83	285	266
Future Volume (vph)	182	506	308	31	522	76	317	352	35	83	285	266
Ideal Flow (vphpl)	1900	1900	1900	1900	1900	1900	1900	1900	1900	1900	1900	1900
Storage Length (ft)	375		140	0		50	200		98	130		93
Storage Lanes	1		1	0		1	1		1	1		1
Taper Length (ft)	50			25			60			93		
Lane Util. Factor	1.00	1.00	1.00	1.00	1.00	1.00	1.00	1.00	1.00	1.00	1.00	1.00
Ped Bike Factor	1.00		0.98						0.98			0.97
Frt			0.850			0.850			0.850			0.850
Flt Protected	0.950				0.997		0.950			0.950		
Satd. Flow (prot)	1770	1863	1583	0	1857	1583	1770	1863	1583	1770	1863	1583
Flt Permitted	0.950				0.997		0.950			0.950		
Satd. Flow (perm)	1764	1863	1549	0	1857	1583	1770	1863	1550	1770	1863	1540
Right Turn on Red			Yes			Yes			Yes			Yes
Satd. Flow (RTOR)			138			113			81			159
Link Speed (mph)		40			40			45			40	
Link Distance (ft)		1789			608			748			775	
Travel Time (s)		30.5			10.4			11.3			13.2	
Confl. Peds. (#/hr)	4											
Confl. Bikes (#/hr)			1						1			5
Peak Hour Factor	0.89	0.89	0.89	0.86	0.86	0.86	0.93	0.93	0.93	0.91	0.91	0.91
Adj. Flow (vph)	204	569	346	36	607	88	341	378	38	91	313	292
Shared Lane Traffic (%)												
Lane Group Flow (vph)	204	569	346	0	643	88	341	378	38	91	313	292
Enter Blocked Intersection	No	No	No	No	No	No	No	No	No	No	No	No
Lane Alignment	Left	Left	Right	Left	Left	Right	Left	Left	Right	Left	Left	Right
Median Width(ft)		12			12			12			12	
Link Offset(ft)		0			0			0			0	
Crosswalk Width(ft)		16			16			16			16	
Two way Left Turn Lane												
Headway Factor	1.00	1.00	1.00	1.00	1.00	1.00	1.00	1.00	1.00	1.00	1.00	1.00
Turning Speed (mph)	15		9	15		9	15		9	15		9
Number of Detectors	1	2	1	1	2	1	1	2	1	1	2	1
Detector Template	Left	Thru	Right	Left	Thru	Right	Left	Thru	Right	Left	Thru	Right
Leading Detector (ft)	20	100	20	20	100	20	20	100	20	20	100	20
Trailing Detector (ft)	0	0	0	0	0	0	0	0	0	0	0	0
Detector 1 Position(ft)	0	0	0	0	0	0	0	0	0	0	0	0
Detector 1 Size(ft)	20	6	20	20	6	20	20	6	20	20	6	20
Detector 1 Type	Cl+Ex	Cl+Ex	Cl+Ex	Cl+Ex	Cl+Ex	Cl+Ex	Cl+Ex	Cl+Ex	Cl+Ex	Cl+Ex	Cl+Ex	Cl+Ex
Detector 1 Channel												
Detector 1 Extend (s)	0.0	0.0	0.0	0.0	0.0	0.0	0.0	0.0	0.0	0.0	0.0	0.0
Detector 1 Queue (s)	0.0	0.0	0.0	0.0	0.0	0.0	0.0	0.0	0.0	0.0	0.0	0.0
Detector 1 Delay (s)	0.0	0.0	0.0	0.0	0.0	0.0	0.0	0.0	0.0	0.0	0.0	0.0
Detector 2 Position(ft)		94			94			94			94	
Detector 2 Size(ft)		6			6			6			6	
Detector 2 Type		Cl+Ex			Cl+Ex			Cl+Ex			Cl+Ex	
Detector 2 Channel												
Detector 2 Extend (s)		0.0			0.0			0.0			0.0	

Lanes, Volumes, Timings  
1: Old Redwood Hwy & Shiloh Road

General Plan 2040 Project Altern. A Conditions  
Timing Plan: Saturday Midday Peak

Lane Group	EBL	EBT	EBR	WBL	WBT	WBR	NBL	NBT	NBR	SBL	SBT	SBR
Turn Type	Split	NA	Perm	Split	NA	Perm	Prot	NA	Perm	Prot	NA	Perm
Protected Phases	2	2		6	6		3	8		7	4	
Permitted Phases			2			6			8			4
Detector Phase	2	2	2	6	6	6	3	8	8	7	4	4
Switch Phase												
Minimum Initial (s)	5.0	5.0	5.0	5.0	5.0	5.0	5.0	5.0	5.0	5.0	5.0	5.0
Minimum Split (s)	34.5	34.5	34.5	42.5	42.5	42.5	9.0	46.5	46.5	9.0	39.5	39.5
Total Split (s)	35.0	35.0	35.0	42.5	42.5	42.5	18.0	48.0	48.0	9.5	39.5	39.5
Total Split (%)	25.9%	25.9%	25.9%	31.5%	31.5%	31.5%	13.3%	35.6%	35.6%	7.0%	29.3%	29.3%
Maximum Green (s)	30.5	30.5	30.5	38.0	38.0	38.0	14.0	43.5	43.5	5.5	35.0	35.0
Yellow Time (s)	3.5	3.5	3.5	3.5	3.5	3.5	3.5	3.5	3.5	3.5	3.5	3.5
All-Red Time (s)	1.0	1.0	1.0	1.0	1.0	1.0	0.5	1.0	1.0	0.5	1.0	1.0
Lost Time Adjust (s)	0.0	0.0	0.0		0.0	0.0	0.0	0.0	0.0	0.0	0.0	0.0
Total Lost Time (s)	4.5	4.5	4.5		4.5	4.5	4.0	4.5	4.5	4.0	4.5	4.5
Lead/Lag	Lead	Lead	Lead	Lag	Lag	Lag	Lead	Lag	Lag	Lead	Lag	Lag
Lead-Lag Optimize?	Yes	Yes	Yes	Yes	Yes	Yes	Yes	Yes	Yes	Yes	Yes	Yes
Vehicle Extension (s)	3.0	3.0	3.0	3.0	3.0	3.0	3.0	3.0	3.0	3.0	3.0	3.0
Recall Mode	None	None	None	None	None	None	None	None	None	None	None	None
Walk Time (s)	7.0	7.0	7.0	7.0	7.0	7.0		7.0	7.0		7.0	7.0
Flash Don't Walk (s)	23.0	23.0	23.0	31.0	31.0	31.0		35.0	35.0		28.0	28.0
Pedestrian Calls (#/hr)	0	0	0	0	0	0		0	0		0	0
Act Effct Green (s)	30.6	30.6	30.6		38.1	38.1	14.0	34.9	34.9	5.5	26.4	26.4
Actuated g/C Ratio	0.24	0.24	0.24		0.30	0.30	0.11	0.28	0.28	0.04	0.21	0.21
v/c Ratio	0.48	1.27	0.72		1.15	0.16	1.74	0.74	0.08	1.18	0.81	0.65
Control Delay (s/veh)	46.9	176.4	36.6		127.8	3.7	388.0	50.8	0.3	213.2	64.0	27.2
Queue Delay	0.0	0.0	0.0		0.0	0.0	0.0	0.0	0.0	0.0	0.0	0.0
Total Delay (s/veh)	46.9	176.4	36.6		127.8	3.7	388.0	50.8	0.3	213.2	64.0	27.2
LOS	D	F	D		F	A	F	D	A	F	E	C
Approach Delay (s/veh)		109.6			112.9			200.1			68.1	
Approach LOS		F			F			F			E	

Intersection Summary

Area Type: Other  
 Cycle Length: 135  
 Actuated Cycle Length: 126.6  
 Natural Cycle: 145  
 Control Type: Actuated-Uncoordinated  
 Maximum v/c Ratio: 1.74  
 Intersection Signal Delay (s/veh): 122.3  
 Intersection LOS: F  
 Intersection Capacity Utilization 103.0%  
 ICU Level of Service G  
 Analysis Period (min) 15

Splits and Phases: 1: Old Redwood Hwy & Shiloh Road

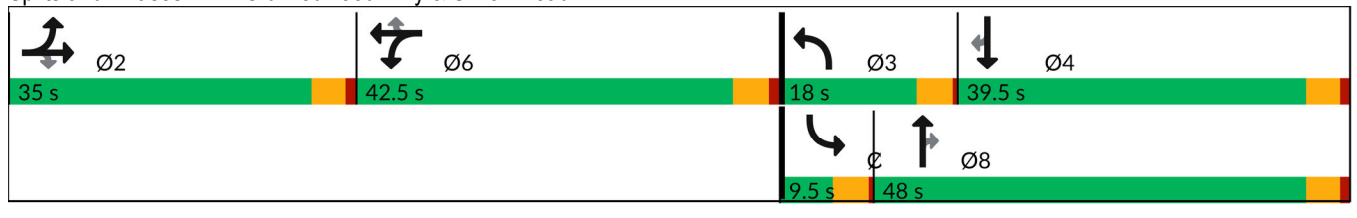

Lanes, Volumes, Timings  
2: Shiloh Road & Hembree Ln

General Plan 2040 Project Altern. A Conditions

Timing Plan: Saturday Midday Peak

Lane Group	EBL	EBT	EBR	WBL	WBT	WBR	NBL	NBT	NBR	SBL	SBT	SBR
Lane Configurations												
Traffic Volume (vph)	918	865	69	110	811	235	111	21	128	236	11	856
Future Volume (vph)	918	865	69	110	811	235	111	21	128	236	11	856
Ideal Flow (vphpl)	1900	1900	1900	1900	1900	1900	1900	1900	1900	1900	1900	1900
Storage Length (ft)	0		0	100		130	0		0	0		0
Storage Lanes	2		0	1		1	1		0	0		1
Taper Length (ft)	25			50			25			25		
Lane Util. Factor	0.97	1.00	1.00	1.00	0.95	0.95	1.00	1.00	1.00	1.00	1.00	1.00
Ped Bike Factor	1.00				1.00							
Frt		0.990			0.966			0.871				0.850
Flt Protected	0.950			0.950			0.950				0.954	
Satd. Flow (prot)	3433	1844	0	1770	3409	0	1770	1622	0	0	1777	1583
Flt Permitted	0.950			0.950			0.950				0.954	
Satd. Flow (perm)	3432	1844	0	1770	3409	0	1770	1622	0	0	1777	1583
Right Turn on Red			Yes			Yes			Yes			Yes
Satd. Flow (RTOR)		7			55			128				96
Link Speed (mph)		40			40			30				35
Link Distance (ft)		302			1789			216				381
Travel Time (s)		5.1			30.5			4.9				7.4
Confl. Peds. (#/hr)	1						1					
Peak Hour Factor	0.94	0.94	1.00	1.00	0.96	0.96	1.00	1.00	1.00	0.91	1.00	0.91
Adj. Flow (vph)	977	920	69	110	845	245	111	21	128	259	11	941
Shared Lane Traffic (%)												
Lane Group Flow (vph)	977	989	0	110	1090	0	111	149	0	0	270	941
Enter Blocked Intersection	No	No	No	No	No	No	No	No	No	No	No	No
Lane Alignment	Left	Left	Right	Left	Left	Right	Left	Left	Right	Left	Left	Right
Median Width(ft)		24			24			12				12
Link Offset(ft)		0			0			0				0
Crosswalk Width(ft)		16			16			16				16
Two way Left Turn Lane												
Headway Factor	1.00	1.00	1.00	1.00	1.00	1.00	1.00	1.00	1.00	1.00	1.00	1.00
Turning Speed (mph)	15		9	15		9	15		9	15		9
Number of Detectors	1	2		1	2		1	2		1	2	1
Detector Template	Left	Thru		Left	Thru		Left	Thru		Left	Thru	Right
Leading Detector (ft)	20	100		20	100		20	100		20	100	20
Trailing Detector (ft)	0	0		0	0		0	0		0	0	0
Detector 1 Position(ft)	0	0		0	0		0	0		0	0	0
Detector 1 Size(ft)	20	6		20	6		20	6		20	6	20
Detector 1 Type	Cl+Ex	Cl+Ex		Cl+Ex	Cl+Ex		Cl+Ex	Cl+Ex		Cl+Ex	Cl+Ex	Cl+Ex
Detector 1 Channel												
Detector 1 Extend (s)	0.0	0.0		0.0	0.0		0.0	0.0		0.0	0.0	0.0
Detector 1 Queue (s)	0.0	0.0		0.0	0.0		0.0	0.0		0.0	0.0	0.0
Detector 1 Delay (s)	0.0	0.0		0.0	0.0		0.0	0.0		0.0	0.0	0.0
Detector 2 Position(ft)		94			94			94				94
Detector 2 Size(ft)		6			6			6				6
Detector 2 Type		Cl+Ex			Cl+Ex			Cl+Ex				Cl+Ex
Detector 2 Channel												
Detector 2 Extend (s)		0.0			0.0			0.0				0.0
Turn Type	Prot	NA		Prot	NA		Split	NA		Split	NA	pt+ov

Lanes, Volumes, Timings  
2: Shiloh Road & Hembree Ln

General Plan 2040 Project Altern. A Conditions  
Timing Plan: Saturday Midday Peak

Lane Group	EBL	EBT	EBR	WBL	WBT	WBR	NBL	NBT	NBR	SBL	SBT	SBR
Protected Phases	5	2		1	6		8	8		4	4	4 5
Permitted Phases												
Detector Phase	5	2		1	6		8	8		4	4	4 5
Switch Phase												
Minimum Initial (s)	3.0	5.0		5.0	5.0		5.0	5.0		5.0	5.0	
Minimum Split (s)	7.5	9.5		9.5	43.5		9.5	9.5		9.5	9.5	
Total Split (s)	21.0	57.0		9.5	45.5		9.5	9.5		14.0	14.0	
Total Split (%)	23.3%	63.3%		10.6%	50.6%		10.6%	10.6%		15.6%	15.6%	
Maximum Green (s)	17.0	53.0		5.5	41.5		5.5	5.5		10.0	10.0	
Yellow Time (s)	3.0	3.0		3.0	3.0		3.0	3.0		3.0	3.0	
All-Red Time (s)	1.0	1.0		1.0	1.0		1.0	1.0		1.0	1.0	
Lost Time Adjust (s)	0.0	0.0		0.0	0.0		0.0	0.0		0.0	0.0	
Total Lost Time (s)	4.0	4.0		4.0	4.0		4.0	4.0		4.0	4.0	
Lead/Lag	Lead	Lag		Lead	Lag							
Lead-Lag Optimize?	Yes	Yes		Yes	Yes							
Vehicle Extension (s)	3.0	3.0		3.0	3.0		3.0	3.0		3.0	3.0	
Recall Mode	None	None		None	None		None	None		None	None	
Walk Time (s)					7.0							
Flash Don't Walk (s)					32.0							
Pedestrian Calls (#/hr)					1							
Act Effct Green (s)	17.1	49.1		5.5	37.5		5.5	5.5		10.1	27.1	
Actuated g/C Ratio	0.20	0.57		0.06	0.43		0.06	0.06		0.12	0.31	
v/c Ratio	1.44	0.94		0.97	0.72		0.98	0.67		1.31	1.67	
Control Delay (s/veh)	234.8	34.8		122.9	21.9		125.3	26.9		203.5	330.7	
Queue Delay	0.0	2.3		0.0	0.0		0.0	0.0		0.0	0.0	
Total Delay (s/veh)	234.8	37.1		122.9	21.9		125.3	26.9		203.5	330.7	
LOS	F	D		F	C		F	C		F	F	
Approach Delay (s/veh)		135.4			31.1			68.9			302.3	
Approach LOS		F			C			E			F	

Intersection Summary







Area Type:	Other
Cycle Length:	90
Actuated Cycle Length:	86.3
Natural Cycle:	140
Control Type:	Actuated-Uncoordinated
Maximum v/c Ratio:	1.67
Intersection Signal Delay (s/veh):	148.3
Intersection LOS:	F
Intersection Capacity Utilization:	102.0%
ICU Level of Service:	G
Analysis Period (min):	15

Splits and Phases: 2: Shiloh Road & Hembree Ln



Lanes, Volumes, Timings  
3: US 101 NB Off-Ramp & Shiloh Road

General Plan 2040 Project Altern. A Conditions  
Timing Plan: Saturday Midday Peak

						
Lane Group	EBT	EBR	WBL	WBT	NBL	NBR
Lane Configurations	↑↑			↑	↓	↑↑
Traffic Volume (vph)	720	0	0	1243	520	1061
Future Volume (vph)	720	0	0	1243	520	1061
Ideal Flow (vphpl)	1900	1900	1900	1900	1900	1900
Storage Length (ft)		0	0		0	265
Storage Lanes		0	0		1	2
Taper Length (ft)			25		25	
Lane Util. Factor	0.95	1.00	1.00	1.00	1.00	0.88
Ped Bike Factor						
Frt						0.850
Flt Protected					0.950	
Satd. Flow (prot)	3539	0	0	1863	1770	2787
Flt Permitted					0.950	
Satd. Flow (perm)	3539	0	0	1863	1770	2787
Right Turn on Red		Yes				Yes
Satd. Flow (RTOR)						189
Link Speed (mph)	40			40	30	
Link Distance (ft)	186			371	769	
Travel Time (s)	3.2			6.3	17.5	
Confl. Bikes (#/hr)		1				
Peak Hour Factor	0.91	0.91	0.89	0.89	0.95	0.95
Adj. Flow (vph)	791	0	0	1397	547	1117
Shared Lane Traffic (%)						
Lane Group Flow (vph)	791	0	0	1397	547	1117
Enter Blocked Intersection	No	No	No	No	No	No
Lane Alignment	Left	Right	Left	Left	Left	Right
Median Width(ft)	0			0	12	
Link Offset(ft)	0			0	0	
Crosswalk Width(ft)	16			16	16	
Two way Left Turn Lane						
Headway Factor	1.00	1.00	1.00	1.00	1.00	1.00
Turning Speed (mph)		9	15		15	9
Number of Detectors	2			2	1	1
Detector Template	Thru			Thru	Left	Right
Leading Detector (ft)	100			100	20	20
Trailing Detector (ft)	0			0	0	0
Detector 1 Position(ft)	0			0	0	0
Detector 1 Size(ft)	6			6	20	20
Detector 1 Type	Cl+Ex			Cl+Ex	Cl+Ex	Cl+Ex
Detector 1 Channel						
Detector 1 Extend (s)	0.0			0.0	0.0	0.0
Detector 1 Queue (s)	0.0			0.0	0.0	0.0
Detector 1 Delay (s)	0.0			0.0	0.0	0.0
Detector 2 Position(ft)	94			94		
Detector 2 Size(ft)	6			6		
Detector 2 Type	Cl+Ex			Cl+Ex		
Detector 2 Channel						
Detector 2 Extend (s)	0.0			0.0		
Turn Type	NA			NA	Prot	Perm

Lanes, Volumes, Timings  
 3: US 101 NB Off-Ramp & Shiloh Road

General Plan 2040 Project Altern. A Conditions  
 Timing Plan: Saturday Midday Peak

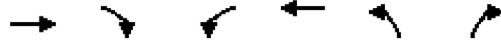

Lane Group	EBT	EBR	WBL	WBT	NBL	NBR
Protected Phases	2			6	8	
Permitted Phases						8
Detector Phase	2			6	8	8
Switch Phase						
Minimum Initial (s)	5.0			5.0	5.0	5.0
Minimum Split (s)	9.5			9.5	9.5	9.5
Total Split (s)	37.0			37.0	35.0	35.0
Total Split (%)	51.4%			51.4%	48.6%	48.6%
Maximum Green (s)	32.5			32.5	30.5	30.5
Yellow Time (s)	3.5			3.5	3.5	3.5
All-Red Time (s)	1.0			1.0	1.0	1.0
Lost Time Adjust (s)	0.0			0.0	0.0	0.0
Total Lost Time (s)	4.5			4.5	4.5	4.5
Lead/Lag						
Lead-Lag Optimize?						
Vehicle Extension (s)	3.0			3.0	3.0	3.0
Recall Mode	None			None	None	None
Act Effct Green (s)	32.6			32.6	28.8	28.8
Actuated g/C Ratio	0.46			0.46	0.41	0.41
v/c Ratio	0.48			1.62	0.76	0.89
Control Delay (s/veh)	14.7			307.0	25.6	26.7
Queue Delay	0.0			0.0	0.0	0.0
Total Delay (s/veh)	14.7			307.0	25.6	26.7
LOS	B			F	C	C
Approach Delay (s/veh)	14.7			307.0	26.3	
Approach LOS	B			F	C	

Intersection Summary

Area Type:	Other
Cycle Length:	72
Actuated Cycle Length:	70.4
Natural Cycle:	150
Control Type:	Actuated-Uncoordinated
Maximum v/c Ratio:	1.62
Intersection Signal Delay (s/veh):	125.7
Intersection LOS:	F
Intersection Capacity Utilization:	168.3%
ICU Level of Service:	H
Analysis Period (min):	15

Splits and Phases: 3: US 101 NB Off-Ramp & Shiloh Road

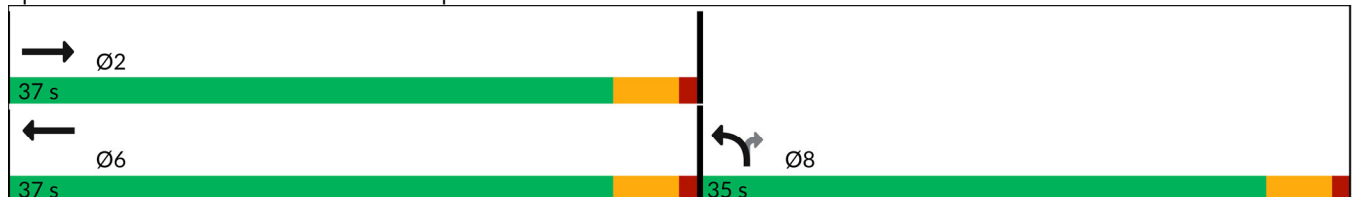



Lanes, Volumes, Timings  
4: Shiloh Road & US 101 SB Off-Ramp

General Plan 2040 Project Altern. A Conditions  
Timing Plan: Saturday Midday Peak

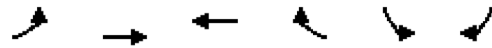

Lane Group	EBL	EBT	WBT	WBR	SBL	SBR
Lane Configurations		↑	↑		↘	↘
Traffic Volume (vph)	0	424	794	0	412	223
Future Volume (vph)	0	424	794	0	412	223
Ideal Flow (vphp)	1900	1900	1900	1900	1900	1900
Storage Length (ft)	0			0	0	275
Storage Lanes	0			0	1	1
Taper Length (ft)	25				25	
Lane Util. Factor	1.00	1.00	1.00	1.00	1.00	1.00
Ped Bike Factor						
Frt						0.850
Flt Protected					0.950	
Satd. Flow (prot)	0	1863	1863	0	1770	1583
Flt Permitted					0.950	
Satd. Flow (perm)	0	1863	1863	0	1770	1583
Right Turn on Red				Yes		Yes
Satd. Flow (RTOR)						242
Link Speed (mph)		40	40		30	
Link Distance (ft)		225	306		486	
Travel Time (s)		3.8	5.2		11.0	
Confl. Bikes (#/hr)				2		
Peak Hour Factor	0.96	0.96	0.96	0.96	0.68	0.68
Adj. Flow (vph)	0	442	827	0	606	328
Shared Lane Traffic (%)						
Lane Group Flow (vph)	0	442	827	0	606	328
Enter Blocked Intersection	No	No	No	No	No	No
Lane Alignment	Left	Left	Left	Right	Left	Right
Median Width(ft)		4	0		12	
Link Offset(ft)		0	0		0	
Crosswalk Width(ft)		16	16		16	
Two way Left Turn Lane						
Headway Factor	1.00	1.00	1.00	1.00	1.00	1.00
Turning Speed (mph)	15			9	15	9
Number of Detectors		2	2		1	1
Detector Template		Thru	Thru		Left	Right
Leading Detector (ft)		100	100		20	20
Trailing Detector (ft)		0	0		0	0
Detector 1 Position(ft)		0	0		0	0
Detector 1 Size(ft)		6	6		20	20
Detector 1 Type		Cl+Ex	Cl+Ex		Cl+Ex	Cl+Ex
Detector 1 Channel						
Detector 1 Extend (s)		0.0	0.0		0.0	0.0
Detector 1 Queue (s)		0.0	0.0		0.0	0.0
Detector 1 Delay (s)		0.0	0.0		0.0	0.0
Detector 2 Position(ft)		94	94			
Detector 2 Size(ft)		6	6			
Detector 2 Type		Cl+Ex	Cl+Ex			
Detector 2 Channel						
Detector 2 Extend (s)		0.0	0.0			
Turn Type		NA	NA		Perm	Perm

Lanes, Volumes, Timings  
4: Shiloh Road & US 101 SB Off-Ramp

General Plan 2040 Project Altern. A Conditions  
Timing Plan: Saturday Midday Peak



Lane Group	EBL	EBT	WBT	WBR	SBL	SBR
Protected Phases		2	6			
Permitted Phases					4	4
Detector Phase		2	6		4	4
Switch Phase						
Minimum Initial (s)		5.0	5.0		5.0	5.0
Minimum Split (s)		9.5	38.5		9.5	9.5
Total Split (s)		69.0	69.0		21.0	21.0
Total Split (%)		76.7%	76.7%		23.3%	23.3%
Maximum Green (s)		64.5	64.5		16.5	16.5
Yellow Time (s)		3.5	3.5		3.5	3.5
All-Red Time (s)		1.0	1.0		1.0	1.0
Lost Time Adjust (s)		0.0	0.0		0.0	0.0
Total Lost Time (s)		4.5	4.5		4.5	4.5
Lead/Lag						
Lead-Lag Optimize?						
Vehicle Extension (s)		3.0	3.0		3.0	3.0
Recall Mode		None	None		None	None
Walk Time (s)			7.0			
Flash Don't Walk (s)			27.0			
Pedestrian Calls (#/hr)			0			
Act Effct Green (s)		30.8	30.8		16.9	16.9
Actuated g/C Ratio		0.54	0.54		0.30	0.30
v/c Ratio		0.44	0.82		1.15	0.51
Control Delay (s/veh)		8.8	18.0		114.7	9.7
Queue Delay		0.0	0.0		0.0	0.0
Total Delay (s/veh)		8.8	18.0		114.7	9.7
LOS		A	B		F	A
Approach Delay (s/veh)		8.8	18.0		77.8	
Approach LOS		A	B		E	

Intersection Summary

Area Type:	Other
Cycle Length:	90
Actuated Cycle Length:	57
Natural Cycle:	70
Control Type:	Actuated-Uncoordinated
Maximum v/c Ratio:	1.15
Intersection Signal Delay (s/veh):	41.5
Intersection LOS:	D
Intersection Capacity Utilization:	156.3%
ICU Level of Service:	H
Analysis Period (min):	15

Splits and Phases: 4: Shiloh Road & US 101 SB Off-Ramp

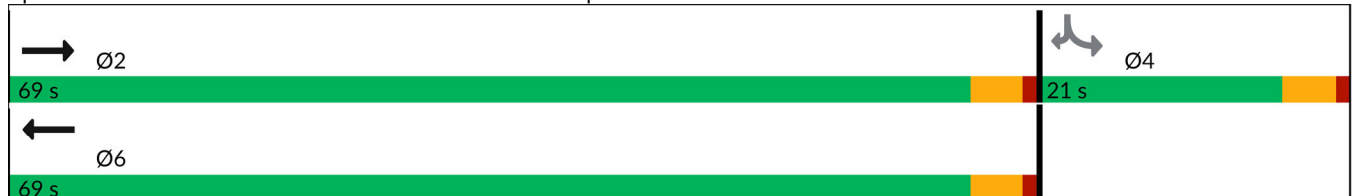

Lanes, Volumes, Timings  
5: Caletti Ave & Shiloh Road



















General Plan 2040 Project Altern. A Conditions

Timing Plan: Saturday Midday Peak

	→	↘	↙	←	↖	↗
Lane Group	EBT	EBR	WBL	WBT	NBL	NBR
Lane Configurations	↑↑		↘	↑	↘	↗
Traffic Volume (vph)	826	30	120	911	24	115
Future Volume (vph)	826	30	120	911	24	115
Ideal Flow (vphp)	1900	1900	1900	1900	1900	1900
Storage Length (ft)		0	68		0	0
Storage Lanes		0	1		1	1
Taper Length (ft)			50		25	
Lane Util. Factor	0.95	0.95	1.00	1.00	1.00	1.00
Ped Bike Factor						
Frt	0.995					0.850
Flt Protected			0.950		0.950	
Satd. Flow (prot)	3522	0	1770	1863	1770	1583
Flt Permitted			0.950		0.950	
Satd. Flow (perm)	3522	0	1770	1863	1770	1583
Link Speed (mph)	40			40	30	
Link Distance (ft)	1081			184	459	
Travel Time (s)	18.4			3.1	10.4	
Confl. Peds. (#/hr)					1	
Confl. Bikes (#/hr)		1				
Peak Hour Factor	0.92	0.92	0.87	0.87	0.78	0.78
Adj. Flow (vph)	898	33	138	1047	31	147
Shared Lane Traffic (%)						
Lane Group Flow (vph)	931	0	138	1047	31	147
Enter Blocked Intersection	No	No	No	No	No	No
Lane Alignment	Left	Right	Left	Left	Left	Right
Median Width(ft)	12			12	12	
Link Offset(ft)	0			0	0	
Crosswalk Width(ft)	16			16	16	
Two way Left Turn Lane						
Headway Factor	1.00	1.00	1.00	1.00	1.00	1.00
Turning Speed (mph)		9	15		15	9
Sign Control	Free			Free	Stop	
<b>Intersection Summary</b>						
Area Type:	Other					
Control Type:	Unsignalized					
Intersection Capacity Utilization	57.9%			ICU Level of Service B		
Analysis Period (min)	15					

Lanes, Volumes, Timings  
6: Conde Lane & Shiloh Road

General Plan 2040 Project Altern. A Conditions  
Timing Plan: Saturday Midday Peak

												
Lane Group	EBL	EBT	EBR	WBL	WBT	WBR	NBL	NBT	NBR	SBL	SBT	SBR
Lane Configurations												
Traffic Volume (vph)	43	554	1	13	614	301	1	0	9	291	0	41
Future Volume (vph)	43	554	1	13	614	301	1	0	9	291	0	41
Ideal Flow (vphpl)	1900	1900	1900	1900	1900	1900	1900	1900	1900	1900	1900	1900
Storage Length (ft)	90		0	127		0	0		0	0		40
Storage Lanes	1		0	1		0	0		0	0		1
Taper Length (ft)	70			40			25			25		
Lane Util. Factor	1.00	0.95	0.95	1.00	0.95	0.95	1.00	1.00	1.00	1.00	1.00	1.00
Ped Bike Factor					0.99							
Frt					0.951			0.880				0.850
Flt Protected	0.950			0.950				0.994			0.950	
Satd. Flow (prot)	1770	3539	0	1770	3341	0	0	1629	0	0	1770	1583
Flt Permitted	0.950			0.950				0.994			0.950	
Satd. Flow (perm)	1770	3539	0	1770	3341	0	0	1629	0	0	1770	1583
Right Turn on Red			Yes			Yes			Yes			No
Satd. Flow (RTOR)					85			102				
Link Speed (mph)		40			40			30				35
Link Distance (ft)		815			1081			418				522
Travel Time (s)		13.9			18.4			9.5				10.2
Confl. Bikes (#/hr)						2						
Peak Hour Factor	0.96	0.96	0.96	0.91	0.91	0.91	0.58	0.58	0.58	0.78	0.78	0.78
Adj. Flow (vph)	45	577	1	14	675	331	2	0	16	373	0	53
Shared Lane Traffic (%)												
Lane Group Flow (vph)	45	578	0	14	1006	0	0	18	0	0	373	53
Enter Blocked Intersection	No	No	No	No	No	No	No	No	No	No	No	No
Lane Alignment	Left	Left	Right	Left	Left	Right	Left	Left	Right	Left	Left	Right
Median Width(ft)		12			12			0				0
Link Offset(ft)		0			0			0				0
Crosswalk Width(ft)		16			16			16				16
Two way Left Turn Lane												
Headway Factor	1.00	1.00	1.00	1.00	1.00	1.00	1.00	1.00	1.00	1.00	1.00	1.00
Turning Speed (mph)	15		9	15		9	15		9	15		9
Number of Detectors	1	2		1	2		1	2		1	1	1
Detector Template	Left	Thru		Left	Thru		Left	Thru		Left	Thru	Right
Leading Detector (ft)	20	100		20	100		20	100		20	30	20
Trailing Detector (ft)	0	0		0	0		0	0		0	0	0
Detector 1 Position(ft)	0	0		0	0		0	0		0	0	0
Detector 1 Size(ft)	20	6		20	6		20	6		20	30	20
Detector 1 Type	Cl+Ex	Cl+Ex		Cl+Ex	Cl+Ex		Cl+Ex	Cl+Ex		Cl+Ex	Cl+Ex	Cl+Ex
Detector 1 Channel												
Detector 1 Extend (s)	0.0	0.0		0.0	0.0		0.0	0.0		0.0	0.0	0.0
Detector 1 Queue (s)	0.0	0.0		0.0	0.0		0.0	0.0		0.0	0.0	0.0
Detector 1 Delay (s)	0.0	0.0		0.0	0.0		0.0	0.0		0.0	0.0	0.0
Detector 2 Position(ft)		94			94			94				
Detector 2 Size(ft)		6			6			6				
Detector 2 Type		Cl+Ex			Cl+Ex			Cl+Ex				
Detector 2 Channel												
Detector 2 Extend (s)		0.0			0.0			0.0				
Turn Type	Prot	NA		Prot	NA		Split	NA		Split	NA	custom

Lanes, Volumes, Timings  
6: Conde Lane & Shiloh Road

General Plan 2040 Project Altern. A Conditions  
Timing Plan: Saturday Midday Peak

Lane Group	EBL	EBT	EBR	WBL	WBT	WBR	NBL	NBT	NBR	SBL	SBT	SBR
Protected Phases	5	2		1	6		7	7		4	4	
Permitted Phases												6
Detector Phase	5	2		1	6		7	7		4	4	6
Switch Phase												
Minimum Initial (s)	8.0	8.0		8.0	8.0		10.0	10.0		11.0	11.0	8.0
Minimum Split (s)	12.5	46.5		12.5	12.5		37.5	37.5		15.5	15.5	12.5
Total Split (s)	13.0	46.5		12.5	45.0		37.5	37.5		15.5	15.5	45.0
Total Split (%)	11.6%	41.5%		11.2%	40.2%		33.5%	33.5%		13.8%	13.8%	40.2%
Maximum Green (s)	8.5	42.0		8.0	40.5		33.0	33.0		11.0	11.0	40.5
Yellow Time (s)	3.5	3.5		3.5	3.5		3.5	3.5		3.5	3.5	3.5
All-Red Time (s)	1.0	1.0		1.0	1.0		1.0	1.0		1.0	1.0	1.0
Lost Time Adjust (s)	0.0	0.0		0.0	0.0		0.0	0.0		0.0	0.0	0.0
Total Lost Time (s)	4.5	4.5		4.5	4.5		4.5	4.5		4.5	4.5	4.5
Lead/Lag	Lead	Lag		Lead	Lag							Lag
Lead-Lag Optimize?	Yes	Yes		Yes	Yes							Yes
Vehicle Extension (s)	3.0	3.0		3.0	3.0		3.0	3.0		3.0	3.0	3.0
Recall Mode	None	None		None	None		None	None		None	None	None
Walk Time (s)		7.0					7.0	7.0				
Flash Don't Walk (s)		35.0					26.0	26.0				
Pedestrian Calls (#/hr)		0					0	0				
Act Effct Green (s)	9.3	30.7		9.2	26.1		11.5			12.6	26.1	
Actuated g/C Ratio	0.16	0.52		0.15	0.44		0.19			0.21	0.44	
v/c Ratio	0.16	0.32		0.05	0.67		0.05			0.99	0.08	
Control Delay (s/veh)	33.0	9.7		33.5	15.9		0.2			80.1	13.0	
Queue Delay	0.0	0.0		0.0	0.0		0.0			0.0	0.0	
Total Delay (s/veh)	33.0	9.7		33.5	15.9		0.2			80.1	13.0	
LOS	C	A		C	B		A			F	B	
Approach Delay (s/veh)		11.4			16.2		0.2			71.8		
Approach LOS		B			B		A			E		

Intersection Summary

Area Type:	Other
Cycle Length:	112
Actuated Cycle Length:	59.5
Natural Cycle:	125
Control Type:	Actuated-Uncoordinated
Maximum v/c Ratio:	0.99
Intersection Signal Delay (s/veh):	25.9
Intersection LOS:	C
Intersection Capacity Utilization:	66.0%
ICU Level of Service:	C
Analysis Period (min):	15

Splits and Phases: 6: Conde Lane & Shiloh Road

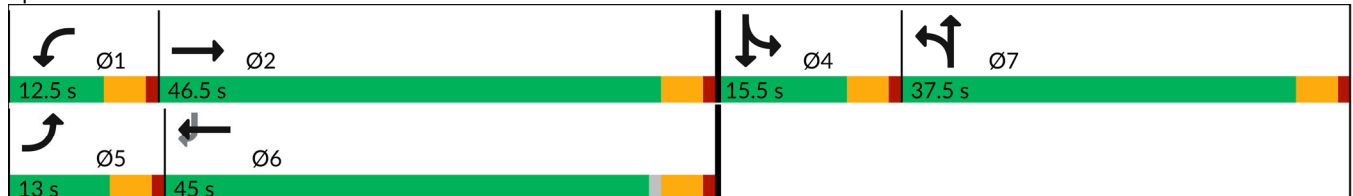

Lanes, Volumes, Timings  
7: Driveway 1/Gridley Drive & Shiloh Road

General Plan 2040 Project Altern. A Conditions  
Timing Plan: Saturday Midday Peak





















Lane Group	EBL	EBT	EBR	WBL	WBT	WBR	NBL	NBT	NBR	SBL	SBT	SBR
Lane Configurations												
Traffic Volume (vph)	30	499	112	0	491	0	116	0	0	0	0	27
Future Volume (vph)	30	499	112	0	491	0	116	0	0	0	0	27
Ideal Flow (vphp)	1900	1900	1900	1900	1900	1900	1900	1900	1900	1900	1900	1900
Storage Length (ft)	0		150	0		0	0		0	0		0
Storage Lanes	0		1	0		0	1		0	0		0
Taper Length (ft)	25			25			25			25		
Lane Util. Factor	1.00	1.00	1.00	1.00	1.00	1.00	1.00	1.00	1.00	1.00	1.00	1.00
Ped Bike Factor												
Frt			0.850								0.865	
Flt Protected		0.997					0.950					
Satd. Flow (prot)	0	1857	1583	0	1863	0	1770	1863	0	0	1611	0
Flt Permitted		0.997					0.950					
Satd. Flow (perm)	0	1857	1583	0	1863	0	1770	1863	0	0	1611	0
Link Speed (mph)		40			40			30			30	
Link Distance (ft)		608			2146			248			715	
Travel Time (s)		10.4			36.6			5.6			16.3	
Confl. Peds. (#/hr)	1											
Confl. Bikes (#/hr)			1			3						
Peak Hour Factor	0.93	0.93	0.93	0.88	0.88	0.88	1.00	1.00	1.00	0.56	0.56	0.56
Adj. Flow (vph)	32	537	120	0	558	0	116	0	0	0	0	48
Shared Lane Traffic (%)												
Lane Group Flow (vph)	0	569	120	0	558	0	116	0	0	0	48	0
Enter Blocked Intersection	No	No	No	No	No	No	No	No	No	No	No	No
Lane Alignment	Left	Left	Right	Left	Left	Right	Left	Left	Right	Left	Left	Right
Median Width(ft)		0			0			12			12	
Link Offset(ft)		0			0			0			0	
Crosswalk Width(ft)		16			16			16			16	
Two way Left Turn Lane												
Headway Factor	1.00	1.00	1.00	1.00	1.00	1.00	1.00	1.00	1.00	1.00	1.00	1.00
Turning Speed (mph)	15		9	15		9	15		9	15		9
Sign Control		Free			Free			Stop			Stop	

Intersection Summary	
Area Type:	Other
Control Type:	Unsignalized
Intersection Capacity Utilization	70.6%
Analysis Period (min)	15
	ICU Level of Service C

Lanes, Volumes, Timings  
8: Old Redwood Hwy & Driveway 2

General Plan 2040 Project Altern. A Conditions

Timing Plan: Saturday Midday Peak

												
Lane Group	EBL	EBT	EBR	WBL	WBT	WBR	NBL	NBT	NBR	SBL	SBT	SBR
Lane Configurations												
Traffic Volume (vph)	1	0	3	68	0	109	1	595	66	105	505	6
Future Volume (vph)	1	0	3	68	0	109	1	595	66	105	505	6
Ideal Flow (vphp)	1900	1900	1900	1900	1900	1900	1900	1900	1900	1900	1900	1900
Storage Length (ft)	0		0	0		0	0		100	50		0
Storage Lanes	0		0	1		0	0		1	1		0
Taper Length (ft)	25			25			25			25		
Lane Util. Factor	1.00	1.00	1.00	1.00	1.00	1.00	1.00	1.00	1.00	1.00	1.00	1.00
Ped Bike Factor												
Frt		0.902			0.850				0.850		0.998	
Flt Protected		0.987		0.950						0.950		
Satd. Flow (prot)	0	1658	0	1770	1583	0	0	1863	1583	1770	1859	0
Flt Permitted		0.987		0.950						0.950		
Satd. Flow (perm)	0	1658	0	1770	1583	0	0	1863	1583	1770	1859	0
Link Speed (mph)		30			30			45			45	
Link Distance (ft)		98			385			520			748	
Travel Time (s)		2.2			8.8			7.9			11.3	
Confl. Peds. (#/hr)							1		4	4		1
Confl. Bikes (#/hr)									3			9
Peak Hour Factor	0.38	0.38	0.38	1.00	1.00	1.00	0.94	0.94	0.94	0.93	0.93	0.93
Adj. Flow (vph)	3	0	8	68	0	109	1	633	70	113	543	6
Shared Lane Traffic (%)												
Lane Group Flow (vph)	0	11	0	68	109	0	0	634	70	113	549	0
Enter Blocked Intersection	No	No	No	No	No	No	No	No	No	No	No	No
Lane Alignment	Left	Left	Right	Left	Left	Right	Left	Left	Right	Left	Left	Right
Median Width(ft)		12			12			12			12	
Link Offset(ft)		0			0			0			0	
Crosswalk Width(ft)		16			16			16			16	
Two way Left Turn Lane												
Headway Factor	1.00	1.00	1.00	1.00	1.00	1.00	1.00	1.00	1.00	1.00	1.00	1.00
Turning Speed (mph)	15		9	15		9	15		9	15		9
Sign Control		Stop			Stop			Free			Free	
<b>Intersection Summary</b>												
Area Type:	Other											
Control Type:	Unsignalized											
Intersection Capacity Utilization	78.7%						ICU Level of Service D					
Analysis Period (min)	15											

Lanes, Volumes, Timings  
9: Driveway 3 & Shiloh Road

General Plan 2040 Project Altern. A Conditions

Timing Plan: Saturday Midday Peak

	→	↘	↙	←	↖	↗
Lane Group	EBT	EBR	WBL	WBT	NBL	NBR
Lane Configurations	↑	↗		↖	↘	↗
Traffic Volume (vph)	136	342	32	127	355	34
Future Volume (vph)	136	342	32	127	355	34
Ideal Flow (vphp)	1900	1900	1900	1900	1900	1900
Storage Length (ft)		200	0		0	0
Storage Lanes		1	0		1	1
Taper Length (ft)			25		25	
Lane Util. Factor	1.00	1.00	1.00	1.00	1.00	1.00
Ped Bike Factor						
Frt		0.850				0.850
Flt Protected				0.990	0.950	
Satd. Flow (prot)	1863	1583	0	1844	1770	1583
Flt Permitted				0.990	0.950	
Satd. Flow (perm)	1863	1583	0	1844	1770	1583
Link Speed (mph)	40			40	30	
Link Distance (ft)	2146			134	402	
Travel Time (s)	36.6			2.3	9.1	
Confl. Peds. (#/hr)		1				
Peak Hour Factor	0.88	0.88	0.80	0.80	1.00	1.00
Adj. Flow (vph)	155	389	40	159	355	34
Shared Lane Traffic (%)						
Lane Group Flow (vph)	155	389	0	199	355	34
Enter Blocked Intersection	No	No	No	No	No	No
Lane Alignment	Left	Right	Left	Left	Left	Right
Median Width(ft)	0			0	12	
Link Offset(ft)	0			0	0	
Crosswalk Width(ft)	16			16	16	
Two way Left Turn Lane						
Headway Factor	1.00	1.00	1.00	1.00	1.00	1.00
Turning Speed (mph)		9	15		15	9
Sign Control	Free			Free	Stop	
<b>Intersection Summary</b>						
Area Type:	Other					
Control Type:	Unsignalized					
Intersection Capacity Utilization	45.5%			ICU Level of Service A		
Analysis Period (min)	15					



Lanes, Volumes, Timings

General Plan 2040 Project Altern. A Conditions

10: US 101 NB Off Ramp/Lakewood Drive & Old Redwood Highway Timing Plan: Saturday Midday Peak



Lane Group	EBL	EBT	EBR	WBL	WBT	WBR	NBL	NBT	NBR	SBL	SBT	SBR
Lane Configurations												
Traffic Volume (vph)	372	472	0	0	719	357	415	393	185	316	0	908
Future Volume (vph)	372	472	0	0	719	357	415	393	185	316	0	908
Ideal Flow (vphpl)	1900	1900	1900	1900	1900	1900	1900	1900	1900	1900	1900	1900
Storage Length (ft)	155		0	0		0	270		150	120		0
Storage Lanes	1		0	0		0	1		1	1		1
Taper Length (ft)	50			25			165			75		
Lane Util. Factor	0.97	1.00	1.00	1.00	0.95	0.95	0.91	0.91	0.95	0.97	1.00	1.00
Ped Bike Factor	1.00				0.99			1.00		1.00		
Flt					0.950			0.958				0.850
Flt Protected	0.950						0.950	0.994		0.950		
Satd. Flow (prot)	3433	1863	0	0	3344	0	1610	3217	0	3433	0	1583
Flt Permitted	0.950						0.950	0.994		0.950		
Satd. Flow (perm)	3431	1863	0	0	3344	0	1610	3217	0	3431	0	1583
Right Turn on Red			Yes			Yes			Yes			Yes
Satd. Flow (RTOR)					100			61				241
Link Speed (mph)		35			35			30				30
Link Distance (ft)		226			617			716				478
Travel Time (s)		4.4			12.0			16.3				10.9
Confl. Peds. (#/hr)	2		1	1		2			1	1		
Confl. Bikes (#/hr)			10			3						
Peak Hour Factor	0.95	0.95	0.95	0.89	0.89	0.89	0.98	0.98	0.98	0.88	0.88	0.88
Adj. Flow (vph)	392	497	0	0	808	401	423	401	189	359	0	1032
Shared Lane Traffic (%)							20%					
Lane Group Flow (vph)	392	497	0	0	1209	0	338	675	0	359	0	1032
Enter Blocked Intersection	No	No	No	No	No	No	No	No	No	No	No	No
Lane Alignment	Left	Left	Right	Left	Left	Right	Left	Left	Right	Left	Left	Right
Median Width(ft)		24			24			24				24
Link Offset(ft)		0			0			0				0
Crosswalk Width(ft)		16			16			16				16
Two way Left Turn Lane												
Headway Factor	1.00	1.00	1.00	1.00	1.00	1.00	1.00	1.00	1.00	1.00	1.00	1.00
Turning Speed (mph)	15		9	15		9	15		9	15		9
Number of Detectors	1	2			2		1	2		1		1
Detector Template	Left	Thru			Thru		Left	Thru		Left		Right
Leading Detector (ft)	20	100			100		20	100		20		20
Trailing Detector (ft)	0	0			0		0	0		0		0
Detector 1 Position(ft)	0	0			0		0	0		0		0
Detector 1 Size(ft)	20	6			6		20	6		20		20
Detector 1 Type	Cl+Ex	Cl+Ex			Cl+Ex		Cl+Ex	Cl+Ex		Cl+Ex		Cl+Ex
Detector 1 Channel												
Detector 1 Extend (s)	0.0	0.0			0.0		0.0	0.0		0.0		0.0
Detector 1 Queue (s)	0.0	0.0			0.0		0.0	0.0		0.0		0.0
Detector 1 Delay (s)	0.0	0.0			0.0		0.0	0.0		0.0		0.0
Detector 2 Position(ft)		94			94			94				
Detector 2 Size(ft)		6			6			6				
Detector 2 Type		Cl+Ex			Cl+Ex			Cl+Ex				
Detector 2 Channel												
Detector 2 Extend (s)		0.0			0.0			0.0				

Lanes, Volumes, Timings

General Plan 2040 Project Altern. A Conditions

10: US 101 NB Off Ramp/Lakewood Drive & Old Redwood Highway Timing Plan: Saturday Midday Peak



Lane Group	EBL	EBT	EBR	WBL	WBT	WBR	NBL	NBT	NBR	SBL	SBT	SBR
Turn Type	Prot	NA			NA		Split	NA		Prot		pm+ov
Protected Phases	5	2			6		8	8		7		5
Permitted Phases												5 8
Detector Phase	5	2			6		8	8		7		5
Switch Phase												
Minimum Initial (s)	7.0	10.0			10.0		10.0	10.0		7.0		7.0
Minimum Split (s)	11.5	32.1			32.1		33.7	33.7		11.5		11.5
Total Split (s)	12.0	45.3			33.3		33.7	33.7		11.5		12.0
Total Split (%)	13.3%	50.1%			36.8%		37.2%	37.2%		12.7%		13.3%
Maximum Green (s)	7.5	40.8			28.8		29.2	29.2		7.0		7.5
Yellow Time (s)	3.5	3.5			3.5		3.5	3.5		3.5		3.5
All-Red Time (s)	1.0	1.0			1.0		1.0	1.0		1.0		1.0
Lost Time Adjust (s)	0.0	0.0			0.0		0.0	0.0		0.0		0.0
Total Lost Time (s)	4.5	4.5			4.5		4.5	4.5		4.5		4.5
Lead/Lag	Lead				Lag		Lag	Lag		Lead		Lead
Lead-Lag Optimize?	Yes				Yes		Yes	Yes		Yes		Yes
Vehicle Extension (s)	3.0	3.0			3.0		3.0	3.0		3.0		3.0
Recall Mode	None	Max			Max		None	None		None		None
Walk Time (s)		7.0			7.0		7.0	7.0				
Flash Don't Walk (s)		20.0			17.0		22.0	22.0				
Pedestrian Calls (#/hr)		0			0		0	0				
Act Effct Green (s)	7.5	41.0			28.9		24.7	24.7		7.0		36.7
Actuated g/C Ratio	0.09	0.48			0.34		0.29	0.29		0.08		0.43
v/c Ratio	1.31	0.56			1.02		0.73	0.70		1.29		1.27
Control Delay (s/veh)	195.7	20.2			59.0		37.9	28.9		188.2		152.3
Queue Delay	0.0	0.0			0.0		0.0	0.0		0.0		0.0
Total Delay (s/veh)	195.7	20.2			59.0		37.9	28.9		188.2		152.3
LOS	F	C			E		D	C		F		F
Approach Delay (s/veh)		97.6			59.0			31.9				161.6
Approach LOS		F			E			C				F

Intersection Summary

Area Type: Other  
 Cycle Length: 90.5  
 Actuated Cycle Length: 86.2  
 Natural Cycle: 110  
 Control Type: Actuated-Uncoordinated  
 Maximum v/c Ratio: 1.31  
 Intersection Signal Delay (s/veh): 92.2      Intersection LOS: F  
 Intersection Capacity Utilization 118.3%      ICU Level of Service H  
 Analysis Period (min) 15

Splits and Phases: 10: US 101 NB Off Ramp/Lakewood Drive & Old Redwood Highway

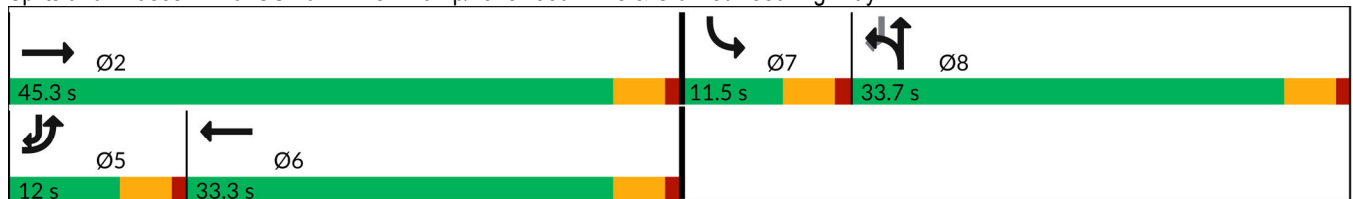

Lanes, Volumes, Timings  
 11: Old Redwood Highway & US 101 NB On Ramp

General Plan 2040 Project Altern. A Conditions  
 Timing Plan: Saturday Midday Peak



Lane Group	EBL	EBT	WBT	WBR	SBL	SBR
Lane Configurations						
Traffic Volume (vph)	112	850	1698	279	0	0
Future Volume (vph)	112	850	1698	279	0	0
Ideal Flow (vphp)	1900	1900	1900	1900	1900	1900
Storage Length (ft)	245			0	0	0
Storage Lanes	1			0	0	0
Taper Length (ft)	50				25	
Lane Util. Factor	1.00	0.95	0.95	0.95	1.00	1.00
Ped Bike Factor						
Frt			0.979			
Flt Protected	0.950					
Satd. Flow (prot)	1770	3539	3465	0	0	0
Flt Permitted	0.950					
Satd. Flow (perm)	1770	3539	3465	0	0	0
Link Speed (mph)		35	35		30	
Link Distance (ft)		531	226		299	
Travel Time (s)		10.3	4.4		6.8	
Confl. Peds. (#/hr)	8			8		
Confl. Bikes (#/hr)				4		
Peak Hour Factor	0.96	0.96	0.92	0.92	0.25	0.25
Adj. Flow (vph)	117	885	1846	303	0	0
Shared Lane Traffic (%)						
Lane Group Flow (vph)	117	885	2149	0	0	0
Enter Blocked Intersection	No	No	No	No	No	No
Lane Alignment	Left	Left	Left	Right	Left	Right
Median Width(ft)		12	12		0	
Link Offset(ft)		0	0		0	
Crosswalk Width(ft)		16	16		16	
Two way Left Turn Lane						
Headway Factor	1.00	1.00	1.00	1.00	1.00	1.00
Turning Speed (mph)	15			9	15	9
Sign Control		Free	Free		Free	

Intersection Summary	
Area Type:	Other
Control Type:	Unsignalized
Intersection Capacity Utilization	90.8%
Analysis Period (min)	15
	ICU Level of Service E

Lanes, Volumes, Timings

General Plan 2040 Project Altern. A Conditions

12: US 101 SB On Ramp/US 101 SB Off Ramp & Old Redwood Highway Timing Plan: Saturday Midday Peak



Lane Group	EBL	EBT	EBR	WBL	WBT	WBR	NBL	NBT	NBR	SBL	SBT	SBR
Lane Configurations		↑↑	↗	↘	↑↑					↘	↕	
Traffic Volume (vph)	0	713	543	632	1060	0	0	0	0	262	1	112
Future Volume (vph)	0	713	543	632	1060	0	0	0	0	262	1	112
Ideal Flow (vphpl)	1900	1900	1900	1900	1900	1900	1900	1900	1900	1900	1900	1900
Storage Length (ft)	0		0	250		0	0		0	420		0
Storage Lanes	0		1	0		0	0		0	1		0
Taper Length (ft)	25			165			25			75		
Lane Util. Factor	1.00	0.95	1.00	1.00	0.95	1.00	1.00	1.00	1.00	0.95	0.95	1.00
Ped Bike Factor			0.98	1.00								
Frt			0.850								0.907	
Flt Protected				0.950						0.950	0.981	
Satd. Flow (prot)	0	3539	1583	1770	3539	0	0	0	0	1681	1575	0
Flt Permitted				0.950						0.950	0.981	
Satd. Flow (perm)	0	3539	1553	1769	3539	0	0	0	0	1681	1575	0
Right Turn on Red			Yes			Yes			Yes			Yes
Satd. Flow (RTOR)			409								98	
Link Speed (mph)		35			35			30			30	
Link Distance (ft)		423			531			621			831	
Travel Time (s)		8.2			10.3			14.1			18.9	
Confl. Peds. (#/hr)	11		2	2		11						
Confl. Bikes (#/hr)			10			2						
Peak Hour Factor	0.97	0.97	0.97	0.96	0.96	0.96	0.25	0.25	0.25	0.72	0.72	0.72
Adj. Flow (vph)	0	735	560	658	1104	0	0	0	0	364	1	156
Shared Lane Traffic (%)										26%		
Lane Group Flow (vph)	0	735	560	658	1104	0	0	0	0	269	252	0
Enter Blocked Intersection	No	No	No	No	No	No	No	No	No	No	No	No
Lane Alignment	Left	Left	Right	Left	Left	Right	Left	Left	Right	Left	Left	Right
Median Width(ft)		24			24			12			12	
Link Offset(ft)		0			0			0			0	
Crosswalk Width(ft)		16			16			16			16	
Two way Left Turn Lane												
Headway Factor	1.00	1.00	1.00	1.00	1.00	1.00	1.00	1.00	1.00	1.00	1.00	1.00
Turning Speed (mph)	15		9	15		9	15		9	15		9
Number of Detectors		2	1	1	2					1	2	
Detector Template		Thru	Right	Left	Thru					Left	Thru	
Leading Detector (ft)		100	20	20	100					20	100	
Trailing Detector (ft)		0	0	0	0					0	0	
Detector 1 Position(ft)		0	0	0	0					0	0	
Detector 1 Size(ft)		6	20	20	6					20	6	
Detector 1 Type		Cl+Ex	Cl+Ex	Cl+Ex	Cl+Ex					Cl+Ex	Cl+Ex	
Detector 1 Channel												
Detector 1 Extend (s)		0.0	0.0	0.0	0.0					0.0	0.0	
Detector 1 Queue (s)		0.0	0.0	0.0	0.0					0.0	0.0	
Detector 1 Delay (s)		0.0	0.0	0.0	0.0					0.0	0.0	
Detector 2 Position(ft)		94			94							94
Detector 2 Size(ft)		6			6							6
Detector 2 Type		Cl+Ex			Cl+Ex							Cl+Ex
Detector 2 Channel												
Detector 2 Extend (s)		0.0			0.0							0.0

Lanes, Volumes, Timings

General Plan 2040 Project Altern. A Conditions

12: US 101 SB On Ramp/US 101 SB Off Ramp & Old Redwood Highway Timing Plan: Saturday Midday Peak



Lane Group	EBL	EBT	EBR	WBL	WBT	WBR	NBL	NBT	NBR	SBL	SBT	SBR
Turn Type		NA	Perm	Prot	NA					Perm	NA	
Protected Phases		6		5	2						8	
Permitted Phases			6							8		
Detector Phase		6	6	5	2					8	8	
Switch Phase												
Minimum Initial (s)		10.0	10.0	7.0	10.0					10.0	10.0	
Minimum Split (s)		32.1	32.1	11.5	38.1					14.7	14.7	
Total Split (s)		32.3	32.3	23.0	55.3					14.7	14.7	
Total Split (%)		46.1%	46.1%	32.9%	79.0%					21.0%	21.0%	
Maximum Green (s)		27.8	27.8	18.5	50.8					10.2	10.2	
Yellow Time (s)		3.5	3.5	3.5	3.5					3.5	3.5	
All-Red Time (s)		1.0	1.0	1.0	1.0					1.0	1.0	
Lost Time Adjust (s)		0.0	0.0	0.0	0.0					0.0	0.0	
Total Lost Time (s)		4.5	4.5	4.5	4.5					4.5	4.5	
Lead/Lag		Lag	Lag	Lead								
Lead-Lag Optimize?		Yes	Yes	Yes								
Vehicle Extension (s)		3.0	3.0	3.0	3.0					3.0	3.0	
Recall Mode		Max	Max	None	Max					None	None	
Walk Time (s)		7.0	7.0		7.0							
Flash Don't Walk (s)		20.0	20.0		25.0							
Pedestrian Calls (#/hr)		0	0		0							
Act Effct Green (s)		27.8	27.8	18.5	50.8					10.2	10.2	
Actuated g/C Ratio		0.40	0.40	0.26	0.73					0.15	0.15	
v/c Ratio		0.52	0.65	1.41	0.43					1.10	0.81	
Control Delay (s/veh)		17.7	8.7	222.1	4.4					120.4	39.3	
Queue Delay		0.0	0.0	0.0	0.0					0.0	0.0	
Total Delay (s/veh)		17.7	8.7	222.1	4.4					120.4	39.3	
LOS		B	A	F	A					F	D	
Approach Delay (s/veh)		13.8			85.7						81.2	
Approach LOS		B			F						F	

Intersection Summary

Area Type:	Other
Cycle Length:	70
Actuated Cycle Length:	70
Natural Cycle:	90
Control Type:	Actuated-Uncoordinated
Maximum v/c Ratio:	1.41
Intersection Signal Delay (s/veh):	59.0
Intersection LOS:	E
Intersection Capacity Utilization:	90.8%
ICU Level of Service:	E
Analysis Period (min):	15



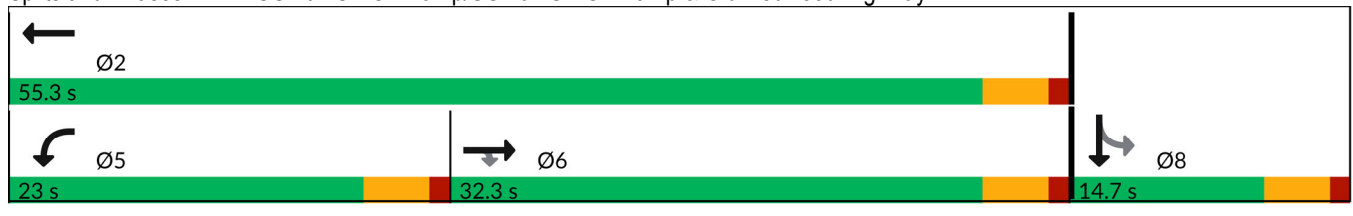



















Splits and Phases: 12: US 101 SB On Ramp/US 101 SB Off Ramp & Old Redwood Highway



Appendix L – General Plan 2040 plus Alternative B Project  
Conditions Intersection Level of Service Worksheets

HCM 6th Signalized Intersection Summary  
1: Old Redwood Hwy & Shiloh Road

General Plan 2040 Project Altern. B Conditions  
Timing Plan: A.M. PEAK

												
Movement	EBL	EBT	EBR	WBL	WBT	WBR	NBL	NBT	NBR	SBL	SBT	SBR
Lane Configurations												
Traffic Volume (veh/h)	313	310	440	40	242	29	364	312	18	53	479	398
Future Volume (veh/h)	313	310	440	40	242	29	364	312	18	53	479	398
Initial Q (Qb), veh	0	0	0	0	0	0	0	0	0	0	0	0
Ped-Bike Adj(A_pbT)	1.00		1.00	1.00		1.00	1.00		1.00	1.00		0.98
Parking Bus, Adj	1.00	1.00	1.00	1.00	1.00	1.00	1.00	1.00	1.00	1.00	1.00	1.00
Work Zone On Approach		No			No			No			No	
Adj Sat Flow, veh/h/ln	1870	1870	1870	1870	1870	1870	1870	1870	1870	1870	1870	1870
Adj Flow Rate, veh/h	386	383	543	45	272	33	391	335	19	62	564	468
Peak Hour Factor	0.81	0.81	0.81	0.89	0.89	0.89	0.93	0.93	0.93	0.85	0.85	0.85
Percent Heavy Veh, %	2	2	2	2	2	2	2	2	2	2	2	2
Cap, veh/h	451	473	401	52	312	310	214	675	572	89	543	450
Arrive On Green	0.25	0.25	0.25	0.20	0.20	0.20	0.12	0.36	0.36	0.05	0.29	0.29
Sat Flow, veh/h	1781	1870	1585	264	1594	1585	1781	1870	1585	1781	1870	1551
Grp Volume(v), veh/h	386	383	543	317	0	33	391	335	19	62	564	468
Grp Sat Flow(s),veh/h/ln	1781	1870	1585	1857	0	1585	1781	1870	1585	1781	1870	1551
Q Serve(g_s), s	24.9	23.2	30.5	20.0	0.0	2.1	14.5	16.8	0.9	4.1	35.0	35.0
Cycle Q Clear(g_c), s	24.9	23.2	30.5	20.0	0.0	2.1	14.5	16.8	0.9	4.1	35.0	35.0
Prop In Lane	1.00		1.00	0.14		1.00	1.00		1.00	1.00		1.00
Lane Grp Cap(c), veh/h	451	473	401	363	0	310	214	675	572	89	543	450
V/C Ratio(X)	0.86	0.81	1.35	0.87	0.00	0.11	1.83	0.50	0.03	0.70	1.04	1.04
Avail Cap(c_a), veh/h	451	473	401	585	0	500	214	675	572	89	543	450
HCM Platoon Ratio	1.00	1.00	1.00	1.00	1.00	1.00	1.00	1.00	1.00	1.00	1.00	1.00
Upstream Filter(I)	1.00	1.00	1.00	1.00	0.00	1.00	1.00	1.00	1.00	1.00	1.00	1.00
Uniform Delay (d), s/veh	43.0	42.3	45.0	47.0	0.0	39.8	53.0	30.0	24.9	56.4	42.8	42.8
Incr Delay (d2), s/veh	15.0	10.1	175.1	8.3	0.0	0.1	389.2	0.6	0.0	21.6	49.1	53.0
Initial Q Delay(d3),s/veh	0.0	0.0	0.0	0.0	0.0	0.0	0.0	0.0	0.0	0.0	0.0	0.0
%ile BackOfQ(50%),veh/ln	12.6	11.8	31.0	9.9	0.0	0.8	29.5	7.4	0.3	2.4	23.0	19.6
Unsig. Movement Delay, s/veh												
LnGrp Delay(d),s/veh	58.0	52.5	220.1	55.4	0.0	40.0	442.2	30.6	25.0	78.0	91.9	95.8
LnGrp LOS	E	D	F	E	A	D	F	C	C	E	F	F
Approach Vol, veh/h		1312			350			745			1094	
Approach Delay, s/veh		123.5			53.9			246.5			92.8	
Approach LOS		F			D			F			F	
Timer - Assigned Phs		2	3	4		6	7	8				
Phs Duration (G+Y+Rc), s		35.0	18.0	39.5		28.1	9.5	48.0				
Change Period (Y+Rc), s		4.5	3.5	4.5		4.5	3.5	4.5				
Max Green Setting (Gmax), s		30.5	14.5	35.0		38.0	6.0	43.5				
Max Q Clear Time (g_c+I1), s		32.5	16.5	37.0		22.0	6.1	18.8				
Green Ext Time (p_c), s		0.0	0.0	0.0		1.6	0.0	1.8				
<b>Intersection Summary</b>												
HCM 6th Ctrl Delay			133.1									
HCM 6th LOS			F									

HCM 6th Signalized Intersection Summary  
2: Shiloh Road & Hembree Ln

General Plan 2040 Project Altern. B Conditions  
Timing Plan: A.M. PEAK



Movement	EBL	EBT	EBR	WBL	WBT	WBR	NBL	NBT	NBR	SBL	SBT	SBR
Lane Configurations												
Traffic Volume (veh/h)	311	918	103	49	865	90	49	11	16	129	18	570
Future Volume (veh/h)	311	918	103	49	865	90	49	11	16	129	18	570
Initial Q (Qb), veh	0	0	0	0	0	0	0	0	0	0	0	0
Ped-Bike Adj(A_pbT)	1.00		1.00	1.00		1.00	1.00		1.00	1.00		1.00
Parking Bus, Adj	1.00	1.00	1.00	1.00	1.00	1.00	1.00	1.00	1.00	1.00	1.00	1.00
Work Zone On Approach		No			No			No			No	
Adj Sat Flow, veh/h/ln	1870	1870	1870	1870	1870	1870	1870	1870	1870	1870	1870	1870
Adj Flow Rate, veh/h	353	1043	103	49	892	93	49	11	16	137	18	606
Peak Hour Factor	0.88	0.88	1.00	1.00	0.97	0.97	1.00	1.00	1.00	0.94	1.00	0.94
Percent Heavy Veh, %	2	2	2	2	2	2	2	2	2	2	2	2
Cap, veh/h	449	1024	101	71	1694	177	86	33	49	183	24	389
Arrive On Green	0.13	0.61	0.61	0.04	0.52	0.52	0.05	0.05	0.05	0.12	0.12	0.12
Sat Flow, veh/h	3456	1675	165	1781	3248	339	1781	689	1002	1583	208	1585
Grp Volume(v), veh/h	353	0	1146	49	488	497	49	0	27	155	0	606
Grp Sat Flow(s),veh/h/ln	1728	0	1841	1781	1777	1809	1781	0	1690	1791	0	1585
Q Serve(g_s), s	8.6	0.0	53.0	2.4	15.7	15.7	2.3	0.0	1.3	7.3	0.0	10.0
Cycle Q Clear(g_c), s	8.6	0.0	53.0	2.4	15.7	15.7	2.3	0.0	1.3	7.3	0.0	10.0
Prop In Lane	1.00		0.09	1.00		0.19	1.00		0.59	0.88		1.00
Lane Grp Cap(c), veh/h	449	0	1126	71	927	944	86	0	82	207	0	389
V/C Ratio(X)	0.79	0.00	1.02	0.69	0.53	0.53	0.57	0.00	0.33	0.75	0.00	1.56
Avail Cap(c_a), veh/h	678	0	1126	113	927	944	113	0	107	207	0	389
HCM Platoon Ratio	1.00	1.00	1.00	1.00	1.00	1.00	1.00	1.00	1.00	1.00	1.00	1.00
Upstream Filter(I)	1.00	0.00	1.00	1.00	1.00	1.00	1.00	0.00	1.00	1.00	0.00	1.00
Uniform Delay (d), s/veh	36.5	0.0	16.8	41.1	13.7	13.7	40.3	0.0	39.9	37.1	0.0	32.7
Incr Delay (d2), s/veh	3.5	0.0	31.4	11.2	0.6	0.5	5.8	0.0	2.3	14.1	0.0	263.8
Initial Q Delay(d3),s/veh	0.0	0.0	0.0	0.0	0.0	0.0	0.0	0.0	0.0	0.0	0.0	0.0
%ile BackOfQ(50%),veh/ln	3.7	0.0	27.3	1.2	5.6	5.7	1.1	0.0	0.6	3.9	0.0	36.4
Unsig. Movement Delay, s/veh												
LnGrp Delay(d),s/veh	40.1	0.0	48.3	52.2	14.2	14.2	46.1	0.0	42.2	51.2	0.0	296.5
LnGrp LOS	D	A	F	D	B	B	D	A	D	D	A	F
Approach Vol, veh/h		1499			1034			76				761
Approach Delay, s/veh		46.3			16.0			44.7				246.6
Approach LOS		D			B			D				F
Timer - Assigned Phs	1	2		4	5	6		8				
Phs Duration (G+Y+Rc), s	7.5	57.0		14.0	15.3	49.2		8.2				
Change Period (Y+Rc), s	4.0	4.0		4.0	4.0	4.0		4.0				
Max Green Setting (Gmax), s	5.5	53.0		10.0	17.0	41.5		5.5				
Max Q Clear Time (g_c+I1), s	4.4	55.0		12.0	10.6	17.7		4.3				
Green Ext Time (p_c), s	0.0	0.0		0.0	0.7	6.4		0.0				
<b>Intersection Summary</b>												
HCM 6th Ctrl Delay				82.2								
HCM 6th LOS				F								



HCM 6th Signalized Intersection Summary  
 3: US 101 NB Off-Ramp & Shiloh Road

General Plan 2040 Project Altern. B Conditions  
 Timing Plan: A.M. PEAK



Movement	EBT	EBR	WBL	WBT	NBL	NBR
Lane Configurations	↑↑			↑	↘	↗
Traffic Volume (veh/h)	731	0	0	1103	813	602
Future Volume (veh/h)	731	0	0	1103	813	602
Initial Q (Qb), veh	0	0	0	0	0	0
Ped-Bike Adj(A_pbT)		1.00	1.00		1.00	1.00
Parking Bus, Adj	1.00	1.00	1.00	1.00	1.00	1.00
Work Zone On Approach	No			No	No	
Adj Sat Flow, veh/h/ln	1870	0	0	1870	1870	1870
Adj Flow Rate, veh/h	803	0	0	1226	1070	792
Peak Hour Factor	0.91	0.91	0.90	0.90	0.76	0.76
Percent Heavy Veh, %	2	0	0	2	2	2
Cap, veh/h	1629	0	0	857	767	1201
Arrive On Green	0.46	0.00	0.00	0.46	0.43	0.43
Sat Flow, veh/h	3741	0	0	1870	1781	2790
Grp Volume(v), veh/h	803	0	0	1226	1070	792
Grp Sat Flow(s),veh/h/ln	1777	0	0	1870	1781	1395
Q Serve(g_s), s	11.4	0.0	0.0	33.0	31.0	16.3
Cycle Q Clear(g_c), s	11.4	0.0	0.0	33.0	31.0	16.3
Prop In Lane		0.00	0.00		1.00	1.00
Lane Grp Cap(c), veh/h	1629	0	0	857	767	1201
V/C Ratio(X)	0.49	0.00	0.00	1.43	1.40	0.66
Avail Cap(c_a), veh/h	1629	0	0	857	767	1201
HCM Platoon Ratio	1.00	1.00	1.00	1.00	1.00	1.00
Upstream Filter(I)	1.00	0.00	0.00	1.00	1.00	1.00
Uniform Delay (d), s/veh	13.6	0.0	0.0	19.5	20.5	16.3
Incr Delay (d2), s/veh	0.2	0.0	0.0	200.3	185.7	1.3
Initial Q Delay(d3),s/veh	0.0	0.0	0.0	0.0	0.0	0.0
%ile BackOfQ(50%),veh/ln	3.9	0.0	0.0	59.5	51.0	4.9
Unsig. Movement Delay, s/veh						
LnGrp Delay(d),s/veh	13.9	0.0	0.0	219.8	206.2	17.6
LnGrp LOS	B	A	A	F	F	B
Approach Vol, veh/h	803			1226	1862	
Approach Delay, s/veh	13.9			219.8	126.0	
Approach LOS	B			F	F	
Timer - Assigned Phs		2			6	8
Phs Duration (G+Y+Rc), s		37.0			37.0	35.0
Change Period (Y+Rc), s		4.0			4.0	4.0
Max Green Setting (Gmax), s		33.0			33.0	31.0
Max Q Clear Time (g_c+I1), s		13.4			35.0	33.0
Green Ext Time (p_c), s		5.2			0.0	0.0
<b>Intersection Summary</b>						
HCM 6th Ctrl Delay			132.4			
HCM 6th LOS			F			

HCM Signalized Intersection Capacity Analysis General Plan 2040 Project Altern. B Conditions  
 4: Shiloh Road & US 101 SB Off-Ramp

Timing Plan: A.M. PEAK



Movement	EBL	EBT	WBT	WBR	SBL	SBR
Lane Configurations		↑	↑		↘	↗
Traffic Volume (vph)	0	422	1153	0	309	184
Future Volume (vph)	0	422	1153	0	309	184
Ideal Flow (vphpl)	1900	1900	1900	1900	1900	1900
Total Lost time (s)		4.0	4.0		4.0	4.0
Lane Util. Factor		1.00	1.00		1.00	1.00
Frt		1.00	1.00		1.00	0.85
Flt Protected		1.00	1.00		0.95	1.00
Satd. Flow (prot)		1863	1863		1770	1583
Flt Permitted		1.00	1.00		0.95	1.00
Satd. Flow (perm)		1863	1863		1770	1583
Peak-hour factor, PHF	0.93	0.93	0.91	0.91	0.92	0.92
Adj. Flow (vph)	0	454	1267	0	336	200
RTOR Reduction (vph)	0	0	0	0	0	86
Lane Group Flow (vph)	0	454	1267	0	336	114
Turn Type		NA	NA		Perm	Perm
Protected Phases		2	6			
Permitted Phases					4	4
Actuated Green, G (s)		61.3	61.3		17.1	17.1
Effective Green, g (s)		61.3	61.3		17.1	17.1
Actuated g/C Ratio		0.71	0.71		0.20	0.20
Clearance Time (s)		4.0	4.0		4.0	4.0
Vehicle Extension (s)		3.0	3.0		3.0	3.0
Lane Grp Cap (vph)		1321	1321		350	313
v/s Ratio Prot		0.24	c0.68			
v/s Ratio Perm					c0.19	0.07
v/c Ratio		0.34	0.96		0.96	0.36
Uniform Delay, d1		4.8	11.4		34.3	30.0
Progression Factor		1.00	1.00		1.00	1.00
Incremental Delay, d2		0.2	15.8		37.1	0.7
Delay (s)		5.0	27.2		71.4	30.7
Level of Service		A	C		E	C
Approach Delay (s)		5.0	27.2		56.2	
Approach LOS		A	C		E	

Intersection Summary			
HCM 2000 Control Delay	29.6	HCM 2000 Level of Service	C
HCM 2000 Volume to Capacity ratio	0.96		
Actuated Cycle Length (s)	86.4	Sum of lost time (s)	8.0
Intersection Capacity Utilization	145.0%	ICU Level of Service	H
Analysis Period (min)	15		

c Critical Lane Group

Intersection						
Int Delay, s/veh	6					
Movement	EBT	EBR	WBL	WBT	NBL	NBR
Lane Configurations	↑↑		↖	↑	↖	↖
Traffic Vol, veh/h	900	14	130	1207	17	122
Future Vol, veh/h	900	14	130	1207	17	122
Conflicting Peds, #/hr	0	0	0	0	0	0
Sign Control	Free	Free	Free	Free	Stop	Stop
RT Channelized	-	None	-	None	-	None
Storage Length	-	-	68	-	0	0
Veh in Median Storage, #	0	-	-	0	0	-
Grade, %	0	-	-	0	0	-
Peak Hour Factor	96	96	87	87	84	84
Heavy Vehicles, %	2	2	2	2	2	2
Mvmt Flow	938	15	149	1387	20	145

Major/Minor	Major1	Major2	Minor1		
Conflicting Flow All	0	0	953	0	2631 477
Stage 1	-	-	-	-	946 -
Stage 2	-	-	-	-	1685 -
Critical Hdwy	-	-	4.13	-	6.63 6.93
Critical Hdwy Stg 1	-	-	-	-	5.83 -
Critical Hdwy Stg 2	-	-	-	-	5.43 -
Follow-up Hdwy	-	-	2.219	-	3.519 3.319
Pot Cap-1 Maneuver	-	-	719	-	22 535
Stage 1	-	-	-	-	339 -
Stage 2	-	-	-	-	164 -
Platoon blocked, %	-	-	-	-	-
Mov Cap-1 Maneuver	-	-	719	-	~ 17 535
Mov Cap-2 Maneuver	-	-	-	-	~ 17 -
Stage 1	-	-	-	-	339 -
Stage 2	-	-	-	-	130 -

Approach	EB	WB	NB
HCM Control Delay, s	0	1.1	85.7
HCM LOS			F

Minor Lane/Major Mvmt	NBLn1	NBLn2	EBT	EBR	WBL	WBT
Capacity (veh/h)	17	535	-	-	719	-
HCM Lane V/C Ratio	1.19	0.271	-	-	0.208	-
HCM Control Delay (s)	\$ 599.2	14.2	-	-	11.3	-
HCM Lane LOS	F	B	-	-	B	-
HCM 95th %tile Q(veh)	3	1.1	-	-	0.8	-

Notes  
 ~: Volume exceeds capacity    \$: Delay exceeds 300s    +: Computation Not Defined    \*: All major volume in platoon

HCM Signalized Intersection Capacity Analysis General Plan 2040 Project Altern. B Conditions  
 6: Conde Lane & Shiloh Road

Timing Plan: A.M. PEAK



Movement	EBL	EBT	EBR	WBL	WBT	WBR	NBL	NBT	NBR	SBL	SBT	SBR
Lane Configurations												
Traffic Volume (vph)	55	535	3	8	854	298	2	1	9	363	0	27
Future Volume (vph)	55	535	3	8	854	298	2	1	9	363	0	27
Ideal Flow (vphpl)	1900	1900	1900	1900	1900	1900	1900	1900	1900	1900	1900	1900
Total Lost time (s)	4.0	4.0		4.0	4.0			4.0			4.0	4.0
Lane Util. Factor	1.00	0.95		1.00	0.95			1.00			1.00	1.00
Frt	1.00	1.00		1.00	0.96			0.90			1.00	0.85
Flt Protected	0.95	1.00		0.95	1.00			0.99			0.95	1.00
Satd. Flow (prot)	1770	3536		1770	3402			1665			1770	1583
Flt Permitted	0.95	1.00		0.95	1.00			0.99			0.95	1.00
Satd. Flow (perm)	1770	3536		1770	3402			1665			1770	1583
Peak-hour factor, PHF	0.95	0.95	0.95	0.85	0.85	0.85	0.57	0.57	0.57	0.86	0.86	0.86
Adj. Flow (vph)	58	563	3	9	1005	351	4	2	16	422	0	31
RTOR Reduction (vph)	0	0	0	0	22	0	0	15	0	0	0	0
Lane Group Flow (vph)	58	566	0	9	1334	0	0	7	0	0	422	31
Turn Type	Prot	NA		Prot	NA		Split	NA		Split	NA	custom
Protected Phases	5	2		1	6		7	7		4	4	
Permitted Phases												6
Actuated Green, G (s)	4.7	46.9		1.3	43.5			3.4			11.3	43.5
Effective Green, g (s)	4.7	46.9		1.3	43.5			3.4			11.3	43.5
Actuated g/C Ratio	0.06	0.59		0.02	0.55			0.04			0.14	0.55
Clearance Time (s)	4.0	4.0		4.0	4.0			4.0			4.0	4.0
Vehicle Extension (s)	3.0	3.0		3.0	3.0			3.0			3.0	3.0
Lane Grp Cap (vph)	105	2101		29	1875			71			253	872
v/s Ratio Prot	c0.03	c0.16		0.01	c0.39			c0.00			c0.24	
v/s Ratio Perm												0.02
v/c Ratio	0.55	0.27		0.31	0.71			0.09			1.67	0.04
Uniform Delay, d1	36.1	7.7		38.4	13.1			36.3			33.8	8.1
Progression Factor	1.00	1.00		1.00	1.00			1.00			1.00	1.00
Incremental Delay, d2	6.2	0.1		6.0	1.3			0.6			317.4	0.0
Delay (s)	42.2	7.8		44.4	14.4			36.8			351.2	8.1
Level of Service	D	A		D	B			D			F	A
Approach Delay (s)		11.0			14.6			36.8			327.7	
Approach LOS		B			B			D			F	

Intersection Summary

HCM 2000 Control Delay	71.4	HCM 2000 Level of Service	E
HCM 2000 Volume to Capacity ratio	0.82		
Actuated Cycle Length (s)	78.9	Sum of lost time (s)	16.0
Intersection Capacity Utilization	76.6%	ICU Level of Service	D
Analysis Period (min)	15		

c Critical Lane Group

Intersection												
Int Delay, s/veh	1.3											
Movement	EBL	EBT	EBR	WBL	WBT	WBR	NBL	NBT	NBR	SBL	SBT	SBR
Lane Configurations		↕	↕		↕		↕	↕			↕	
Traffic Vol, veh/h	12	353	47	0	187	0	33	0	0	1	0	24
Future Vol, veh/h	12	353	47	0	187	0	33	0	0	1	0	24
Conflicting Peds, #/hr	0	0	0	0	0	0	0	0	0	0	0	0
Sign Control	Free	Free	Free	Free	Free	Free	Stop	Stop	Stop	Stop	Stop	Stop
RT Channelized	-	-	None	-	-	None	-	-	None	-	-	None
Storage Length	-	-	150	-	-	-	0	-	-	-	-	-
Veh in Median Storage, #	-	0	-	-	0	-	-	0	-	-	0	-
Grade, %	-	0	-	-	0	-	-	0	-	-	0	-
Peak Hour Factor	91	91	91	85	85	85	100	100	100	71	71	71
Heavy Vehicles, %	2	2	2	2	2	2	2	2	2	2	2	2
Mvmt Flow	13	388	52	0	220	0	33	0	0	1	0	34

Major/Minor	Major1			Major2			Minor1			Minor2		
Conflicting Flow All	220	0	0	440	0	0	651	634	388	660	686	220
Stage 1	-	-	-	-	-	-	414	414	-	220	220	-
Stage 2	-	-	-	-	-	-	237	220	-	440	466	-
Critical Hdwy	4.12	-	-	4.12	-	-	7.12	6.52	6.22	7.12	6.52	6.22
Critical Hdwy Stg 1	-	-	-	-	-	-	6.12	5.52	-	6.12	5.52	-
Critical Hdwy Stg 2	-	-	-	-	-	-	6.12	5.52	-	6.12	5.52	-
Follow-up Hdwy	2.218	-	-	2.218	-	-	3.518	4.018	3.318	3.518	4.018	3.318
Pot Cap-1 Maneuver	1349	-	-	1120	-	-	382	397	660	376	370	820
Stage 1	-	-	-	-	-	-	616	593	-	782	721	-
Stage 2	-	-	-	-	-	-	766	721	-	596	562	-
Platoon blocked, %	-	-	-	-	-	-	-	-	-	-	-	-
Mov Cap-1 Maneuver	1349	-	-	1120	-	-	363	392	660	372	365	820
Mov Cap-2 Maneuver	-	-	-	-	-	-	363	392	-	372	365	-
Stage 1	-	-	-	-	-	-	608	585	-	772	721	-
Stage 2	-	-	-	-	-	-	734	721	-	588	555	-

Approach	EB	WB	NB	SB
HCM Control Delay, s	0.2	0	15.9	9.8
HCM LOS			C	A

Minor Lane/Major Mvmt	NBLn1	NBLn2	EBL	EBT	EBR	WBL	WBT	WBR	SBLn1
Capacity (veh/h)	363	-	1349	-	-	1120	-	-	782
HCM Lane V/C Ratio	0.091	-	0.01	-	-	-	-	-	0.045
HCM Control Delay (s)	15.9	0	7.7	0	-	0	-	-	9.8
HCM Lane LOS	C	A	A	A	-	A	-	-	A
HCM 95th %tile Q(veh)	0.3	-	0	-	-	0	-	-	0.1

Intersection												
Int Delay, s/veh	1.6											
Movement	EBL	EBT	EBR	WBL	WBT	WBR	NBL	NBT	NBR	SBL	SBT	SBR
Lane Configurations		↕		↕	↕			↕	↕	↕	↕	
Traffic Vol, veh/h	1	0	0	19	0	31	0	662	28	45	914	0
Future Vol, veh/h	1	0	0	19	0	31	0	662	28	45	914	0
Conflicting Peds, #/hr	0	0	0	0	0	0	0	0	1	1	0	0
Sign Control	Stop	Stop	Stop	Stop	Stop	Stop	Free	Free	Free	Free	Free	Free
RT Channelized	-	-	None	-	-	None	-	-	None	-	-	None
Storage Length	-	-	-	0	-	-	-	-	100	50	-	-
Veh in Median Storage, #	-	0	-	-	0	-	-	0	-	-	0	-
Grade, %	-	0	-	-	0	-	-	0	-	-	0	-
Peak Hour Factor	25	25	25	100	100	100	99	99	99	90	90	90
Heavy Vehicles, %	2	2	2	2	2	2	2	2	2	2	2	2
Mvmt Flow	4	0	0	19	0	31	0	669	28	50	1016	0

Major/Minor	Minor2		Minor1		Major1		Major2					
Conflicting Flow All	1815	1814	1016	1786	1786	670	1016	0	0	698	0	0
Stage 1	1116	1116	-	670	670	-	-	-	-	-	-	-
Stage 2	699	698	-	1116	1116	-	-	-	-	-	-	-
Critical Hdwy	7.12	6.52	6.22	7.12	6.52	6.22	4.12	-	-	4.12	-	-
Critical Hdwy Stg 1	6.12	5.52	-	6.12	5.52	-	-	-	-	-	-	-
Critical Hdwy Stg 2	6.12	5.52	-	6.12	5.52	-	-	-	-	-	-	-
Follow-up Hdwy	3.518	4.018	3.318	3.518	4.018	3.318	2.218	-	-	2.218	-	-
Pot Cap-1 Maneuver	60	78	289	63	81	457	683	-	-	898	-	-
Stage 1	252	283	-	446	455	-	-	-	-	-	-	-
Stage 2	430	442	-	252	283	-	-	-	-	-	-	-
Platoon blocked, %								-	-	-	-	-
Mov Cap-1 Maneuver	54	74	289	60	76	457	683	-	-	897	-	-
Mov Cap-2 Maneuver	54	74	-	60	76	-	-	-	-	-	-	-
Stage 1	252	267	-	446	455	-	-	-	-	-	-	-
Stage 2	401	442	-	238	267	-	-	-	-	-	-	-

Approach	EB		WB		NB		SB	
HCM Control Delay, s	76.9		42.8		0		0.4	
HCM LOS	F		E					

Minor Lane/Major Mvmt	NBL	NBT	NBR	EBLn1	WBLn1	WBLn2	SBL	SBT	SBR
Capacity (veh/h)	683	-	-	54	60	457	897	-	-
HCM Lane V/C Ratio	-	-	-	0.074	0.317	0.068	0.056	-	-
HCM Control Delay (s)	0	-	-	76.9	90.7	13.5	9.2	-	-
HCM Lane LOS	A	-	-	F	F	B	A	-	-
HCM 95th %tile Q(veh)	0	-	-	0.2	1.1	0.2	0.2	-	-

Intersection						
Int Delay, s/veh	2.3					
Movement	EBT	EBR	WBL	WBT	NBL	NBR
Lane Configurations	↑	↗		↖	↖	↗
Traffic Vol, veh/h	207	145	14	77	101	10
Future Vol, veh/h	207	145	14	77	101	10
Conflicting Peds, #/hr	0	0	0	0	0	0
Sign Control	Free	Free	Free	Free	Stop	Stop
RT Channelized	-	None	-	None	-	None
Storage Length	-	200	-	-	0	0
Veh in Median Storage, #	0	-	-	0	0	-
Grade, %	0	-	-	0	0	-
Peak Hour Factor	85	85	81	81	100	100
Heavy Vehicles, %	2	2	2	2	2	2
Mvmt Flow	244	171	17	95	101	10

Major/Minor	Major1	Major2	Minor1		
Conflicting Flow All	0	0	415	0	373 244
Stage 1	-	-	-	-	244 -
Stage 2	-	-	-	-	129 -
Critical Hdwy	-	-	4.12	-	6.42 6.22
Critical Hdwy Stg 1	-	-	-	-	5.42 -
Critical Hdwy Stg 2	-	-	-	-	5.42 -
Follow-up Hdwy	-	-	2.218	-	3.518 3.318
Pot Cap-1 Maneuver	-	-	1144	-	628 795
Stage 1	-	-	-	-	797 -
Stage 2	-	-	-	-	897 -
Platoon blocked, %	-	-	-	-	-
Mov Cap-1 Maneuver	-	-	1144	-	618 795
Mov Cap-2 Maneuver	-	-	-	-	618 -
Stage 1	-	-	-	-	797 -
Stage 2	-	-	-	-	883 -

Approach	EB	WB	NB
HCM Control Delay, s	0	1.3	11.8
HCM LOS			B

Minor Lane/Major Mvmt	NBLn1	NBLn2	EBT	EBR	WBL	WBT
Capacity (veh/h)	618	795	-	-	1144	-
HCM Lane V/C Ratio	0.163	0.013	-	-	0.015	-
HCM Control Delay (s)	12	9.6	-	-	8.2	0
HCM Lane LOS	B	A	-	-	A	A
HCM 95th %tile Q(veh)	0.6	0	-	-	0	-

HCM 6th Signalized Intersection Summary      General Plan 2040 Project Altern. B Conditions  
 10: US 101 NB Off Ramp/Lakewood Drive & Old Redwood Highway      Timing Plan: A.M. PEAK

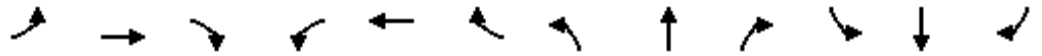

Movement	EBL	EBT	EBR	WBL	WBT	WBR	NBL	NBT	NBR	SBL	SBT	SBR
Lane Configurations	↔↔	↑			↑↑		↔	↔↔		↔↔		↔
Traffic Volume (veh/h)	264	638	0	0	669	156	224	255	92	255	0	679
Future Volume (veh/h)	264	638	0	0	669	156	224	255	92	255	0	679
Initial Q (Qb), veh	0	0	0	0	0	0	0	0	0	0	0	0
Ped-Bike Adj(A_pbT)	1.00		1.00	1.00		0.99	1.00		1.00	1.00		1.00
Parking Bus, Adj	1.00	1.00	1.00	1.00	1.00	1.00	1.00	1.00	1.00	1.00	1.00	1.00
Work Zone On Approach		No			No			No			No	
Adj Sat Flow, veh/h/ln	1870	1870	0	0	1870	1870	1870	1870	1870	1870	0	1870
Adj Flow Rate, veh/h	311	751	0	0	806	188	211	336	102	287	0	0
Peak Hour Factor	0.85	0.85	0.85	0.83	0.83	0.83	0.90	0.90	0.90	0.89	0.89	0.89
Percent Heavy Veh, %	2	2	0	0	2	2	2	2	2	2	0	2
Cap, veh/h	419	1202	0	0	1304	304	358	555	166	0	0	0
Arrive On Green	0.12	0.64	0.00	0.00	0.46	0.46	0.20	0.20	0.20	0.00	0.00	0.00
Sat Flow, veh/h	3456	1870	0	0	2945	665	1781	2764	825		0	
Grp Volume(v), veh/h	311	751	0	0	502	492	211	226	212		0.0	
Grp Sat Flow(s),veh/h/ln	1728	1870	0	0	1777	1740	1781	1870	1719			
Q Serve(g_s), s	5.4	15.0	0.0	0.0	13.4	13.4	6.7	6.9	7.1			
Cycle Q Clear(g_c), s	5.4	15.0	0.0	0.0	13.4	13.4	6.7	6.9	7.1			
Prop In Lane	1.00		0.00	0.00		0.38	1.00		0.48			
Lane Grp Cap(c), veh/h	419	1202	0	0	813	796	358	375	345			
V/C Ratio(X)	0.74	0.62	0.00	0.00	0.62	0.62	0.59	0.60	0.62			
Avail Cap(c_a), veh/h	497	1202	0	0	813	796	826	867	797			
HCM Platoon Ratio	1.00	1.00	1.00	1.00	1.00	1.00	1.00	1.00	1.00			
Upstream Filter(I)	1.00	1.00	0.00	0.00	1.00	1.00	1.00	1.00	1.00			
Uniform Delay (d), s/veh	26.5	6.7	0.0	0.0	12.8	12.8	22.7	22.7	22.8			
Incr Delay (d2), s/veh	4.9	2.5	0.0	0.0	3.5	3.6	1.6	1.5	1.8			
Initial Q Delay(d3),s/veh	0.0	0.0	0.0	0.0	0.0	0.0	0.0	0.0	0.0			
%ile BackOfQ(50%),veh/ln	2.4	4.7	0.0	0.0	5.2	5.1	2.8	3.0	2.8			
Unsig. Movement Delay, s/veh												
LnGrp Delay(d),s/veh	31.4	9.1	0.0	0.0	16.3	16.4	24.2	24.3	24.6			
LnGrp LOS	C	A	A	A	B	B	C	C	C			
Approach Vol, veh/h		1062			994			649				
Approach Delay, s/veh		15.7			16.4			24.4				
Approach LOS		B			B			C				
Timer - Assigned Phs		2			5	6		8				
Phs Duration (G+Y+Rc), s		45.3			11.6	33.7		17.3				
Change Period (Y+Rc), s		5.1			4.0	5.1		4.7				
Max Green Setting (Gmax), s		40.2			9.0	27.2		29.0				
Max Q Clear Time (g_c+I1), s		17.0			7.4	15.4		9.1				
Green Ext Time (p_c), s		5.5			0.2	4.9		3.2				

**Intersection Summary**

HCM 6th Ctrl Delay	18.0
HCM 6th LOS	B

**Notes**

User approved volume balancing among the lanes for turning movement.  
 Unsignalized Delay for [SBR] is excluded from calculations of the approach delay and intersection delay.



HCM 6th Signalized Intersection Summary      General Plan 2040 Project Altern. B Conditions  
 12: US 101 SB On Ramp/US 101 SB Off Ramp & Old Redwood Highway      Timing Plan: A.M. PEAK



Movement	EBL	EBT	EBR	WBL	WBT	WBR	NBL	NBT	NBR	SBL	SBT	SBR
Lane Configurations		↑↑	↗	↘	↑↑					↘	↔	
Traffic Volume (veh/h)	0	699	814	559	742	0	0	0	0	185	0	144
Future Volume (veh/h)	0	699	814	559	742	0	0	0	0	185	0	144
Initial Q (Qb), veh	0	0	0	0	0	0				0	0	0
Ped-Bike Adj(A_pbT)	1.00		0.98	1.00		1.00				1.00		1.00
Parking Bus, Adj	1.00	1.00	1.00	1.00	1.00	1.00				1.00	1.00	1.00
Work Zone On Approach		No			No						No	
Adj Sat Flow, veh/h/ln	0	1870	1870	1870	1870	0				1870	1870	1870
Adj Flow Rate, veh/h	0	760	885	628	834	0				203	35	0
Peak Hour Factor	0.92	0.92	0.92	0.89	0.89	0.89				0.81	0.81	0.81
Percent Heavy Veh, %	0	2	2	2	2	0				2	2	2
Cap, veh/h	0	1208	530	646	2674	0				223	234	
Arrive On Green	0.00	0.34	0.34	0.36	0.75	0.00				0.13	0.13	0.00
Sat Flow, veh/h	0	3647	1560	1781	3647	0				1781	1870	0
Grp Volume(v), veh/h	0	760	885	628	834	0				203	35	0
Grp Sat Flow(s),veh/h/ln	0	1777	1560	1781	1777	0				1781	1870	0
Q Serve(g_s), s	0.0	14.4	27.2	27.8	6.1	0.0				9.0	1.3	0.0
Cycle Q Clear(g_c), s	0.0	14.4	27.2	27.8	6.1	0.0				9.0	1.3	0.0
Prop In Lane	0.00		1.00	1.00		0.00				1.00		0.00
Lane Grp Cap(c), veh/h	0	1208	530	646	2674	0				223	234	
V/C Ratio(X)	0.00	0.63	1.67	0.97	0.31	0.00				0.91	0.15	
Avail Cap(c_a), veh/h	0	1208	530	646	2674	0				223	234	
HCM Platoon Ratio	1.00	1.00	1.00	1.00	1.00	1.00				1.00	1.00	1.00
Upstream Filter(I)	0.00	1.00	1.00	1.00	1.00	0.00				1.00	1.00	0.00
Uniform Delay (d), s/veh	0.0	22.2	26.4	25.1	3.2	0.0				34.6	31.2	0.0
Incr Delay (d2), s/veh	0.0	2.5	309.2	28.5	0.3	0.0				37.2	0.3	0.0
Initial Q Delay(d3),s/veh	0.0	0.0	0.0	0.0	0.0	0.0				0.0	0.0	0.0
%ile BackOfQ(50%),veh/ln	0.0	6.0	54.8	15.8	1.4	0.0				6.1	0.6	0.0
Unsig. Movement Delay, s/veh												
LnGrp Delay(d),s/veh	0.0	24.7	335.6	53.7	3.5	0.0				71.7	31.5	0.0
LnGrp LOS	A	C	F	D	A	A				E	C	
Approach Vol, veh/h		1645			1462						238	
Approach Delay, s/veh		191.9			25.0						65.8	
Approach LOS		F			C						E	
Timer - Assigned Phs		2			5	6		8				
Phs Duration (G+Y+Rc), s		65.3			33.0	32.3		14.7				
Change Period (Y+Rc), s		5.1			4.0	5.1		4.7				
Max Green Setting (Gmax), s		60.2			29.0	27.2		10.0				
Max Q Clear Time (g_c+I1), s		8.1			29.8	29.2		11.0				
Green Ext Time (p_c), s		6.9			0.0	0.0		0.0				

**Intersection Summary**























HCM 6th Ctrl Delay	110.0
HCM 6th LOS	F

**Notes**

- User approved volume balancing among the lanes for turning movement.
- User approved ignoring U-Turning movement.
- Unsignalized Delay for [SBR] is excluded from calculations of the approach delay and intersection delay.

HCM 6th Signalized Intersection Summary  
 1: Old Redwood Hwy & Shiloh Road

























General Plan 2040 Project Altern. B Conditions  
 Timing Plan: P.M. Peak

												
Movement	EBL	EBT	EBR	WBL	WBT	WBR	NBL	NBT	NBR	SBL	SBT	SBR
Lane Configurations												
Traffic Volume (veh/h)	317	398	635	44	393	64	656	565	44	79	545	265
Future Volume (veh/h)	317	398	635	44	393	64	656	565	44	79	545	265
Initial Q (Qb), veh	0	0	0	0	0	0	0	0	0	0	0	0
Ped-Bike Adj(A_pbT)	1.00		1.00	1.00		1.00	1.00		0.98	1.00		0.97
Parking Bus, Adj	1.00	1.00	1.00	1.00	1.00	1.00	1.00	1.00	1.00	1.00	1.00	1.00
Work Zone On Approach		No			No			No			No	
Adj Sat Flow, veh/h/ln	1870	1870	1870	1870	1870	1870	1870	1870	1870	1870	1870	1870
Adj Flow Rate, veh/h	327	410	655	48	432	70	705	608	47	85	586	285
Peak Hour Factor	0.97	0.97	0.97	0.91	0.91	0.91	0.93	0.93	0.93	0.93	0.93	0.93
Percent Heavy Veh, %	2	2	2	2	2	2	2	2	2	2	2	2
Cap, veh/h	407	427	361	51	458	432	194	610	504	80	490	405
Arrive On Green	0.23	0.23	0.23	0.27	0.27	0.27	0.11	0.33	0.33	0.04	0.26	0.26
Sat Flow, veh/h	1781	1870	1582	186	1675	1582	1781	1870	1546	1781	1870	1544
Grp Volume(v), veh/h	327	410	655	480	0	70	705	608	47	85	586	285
Grp Sat Flow(s),veh/h/ln	1781	1870	1582	1861	0	1582	1781	1870	1546	1781	1870	1544
Q Serve(g_s), s	23.2	28.9	30.5	33.7	0.0	4.5	14.5	43.3	2.8	6.0	35.0	22.3
Cycle Q Clear(g_c), s	23.2	28.9	30.5	33.7	0.0	4.5	14.5	43.3	2.8	6.0	35.0	22.3
Prop In Lane	1.00		1.00	0.10		1.00	1.00		1.00	1.00		1.00
Lane Grp Cap(c), veh/h	407	427	361	508	0	432	194	610	504	80	490	405
V/C Ratio(X)	0.80	0.96	1.81	0.94	0.00	0.16	3.64	1.00	0.09	1.06	1.19	0.70
Avail Cap(c_a), veh/h	407	427	361	530	0	450	194	610	504	80	490	405
HCM Platoon Ratio	1.00	1.00	1.00	1.00	1.00	1.00	1.00	1.00	1.00	1.00	1.00	1.00
Upstream Filter(I)	1.00	1.00	1.00	1.00	0.00	1.00	1.00	1.00	1.00	1.00	1.00	1.00
Uniform Delay (d), s/veh	48.6	50.9	51.5	47.5	0.0	36.9	59.5	44.9	31.3	63.7	49.2	44.5
Incr Delay (d2), s/veh	11.1	33.1	376.3	25.4	0.0	0.2	1202.0	35.7	0.1	118.4	106.2	5.4
Initial Q Delay(d3),s/veh	0.0	0.0	0.0	0.0	0.0	0.0	0.0	0.0	0.0	0.0	0.0	0.0
%ile BackOfQ(50%),veh/ln	11.4	17.2	49.5	18.9	0.0	1.7	71.0	25.3	1.0	5.3	30.4	9.0
Unsig. Movement Delay, s/veh												
LnGrp Delay(d),s/veh	59.7	83.9	427.8	72.9	0.0	37.1	1261.4	80.7	31.4	182.1	155.4	50.0
LnGrp LOS	E	F	F	E	A	D	F	F	C	F	F	D
Approach Vol, veh/h		1392			550			1360			956	
Approach Delay, s/veh		240.0			68.3			691.1			126.4	
Approach LOS		F			E			F			F	
Timer - Assigned Phs		2	3	4		6	7	8				
Phs Duration (G+Y+Rc), s		35.0	18.0	39.5		41.0	9.5	48.0				
Change Period (Y+Rc), s		4.5	3.5	4.5		4.5	3.5	4.5				
Max Green Setting (Gmax), s		30.5	14.5	35.0		38.0	6.0	43.5				
Max Q Clear Time (g_c+I1), s		32.5	16.5	37.0		35.7	8.0	45.3				
Green Ext Time (p_c), s		0.0	0.0	0.0		0.7	0.0	0.0				
<b>Intersection Summary</b>												
HCM 6th Ctrl Delay			336.4									
HCM 6th LOS			F									

HCM 6th Signalized Intersection Summary  
2: Shiloh Road & Hembree Ln

General Plan 2040 Project Altern. B Conditions

Timing Plan: P.M. Peak

												
Movement	EBL	EBT	EBR	WBL	WBT	WBR	NBL	NBT	NBR	SBL	SBT	SBR
Lane Configurations	 			 	 						 	
Traffic Volume (veh/h)	661	1147	69	110	1086	118	111	21	128	174	11	526
Future Volume (veh/h)	661	1147	69	110	1086	118	111	21	128	174	11	526
Initial Q (Qb), veh	0	0	0	0	0	0	0	0	0	0	0	0
Ped-Bike Adj(A_pbT)	1.00		1.00	1.00		1.00	1.00		1.00	1.00		1.00
Parking Bus, Adj	1.00	1.00	1.00	1.00	1.00	1.00	1.00	1.00	1.00	1.00	1.00	1.00
Work Zone On Approach		No			No			No			No	
Adj Sat Flow, veh/h/ln	1870	1870	1870	1870	1870	1870	1870	1870	1870	1870	1870	1870
Adj Flow Rate, veh/h	703	1220	69	110	1248	136	111	21	128	183	11	554
Peak Hour Factor	0.94	0.94	1.00	1.00	0.87	0.87	1.00	1.00	1.00	0.95	1.00	0.95
Percent Heavy Veh, %	2	2	2	2	2	2	2	2	2	2	2	2
Cap, veh/h	653	1032	58	109	1490	162	109	14	85	187	11	476
Arrive On Green	0.19	0.59	0.59	0.06	0.46	0.46	0.06	0.06	0.06	0.11	0.11	0.11
Sat Flow, veh/h	3456	1753	99	1781	3232	351	1781	228	1392	1685	101	1585
Grp Volume(v), veh/h	703	0	1289	110	684	700	111	0	149	194	0	554
Grp Sat Flow(s),veh/h/ln	1728	0	1852	1781	1777	1807	1781	0	1620	1786	0	1585
Q Serve(g_s), s	17.0	0.0	53.0	5.5	30.4	30.7	5.5	0.0	5.5	9.7	0.0	10.0
Cycle Q Clear(g_c), s	17.0	0.0	53.0	5.5	30.4	30.7	5.5	0.0	5.5	9.7	0.0	10.0
Prop In Lane	1.00		0.05	1.00		0.19	1.00		0.86	0.94		1.00
Lane Grp Cap(c), veh/h	653	0	1091	109	819	833	109	0	99	198	0	476
V/C Ratio(X)	1.08	0.00	1.18	1.01	0.84	0.84	1.02	0.00	1.51	0.98	0.00	1.17
Avail Cap(c_a), veh/h	653	0	1091	109	819	833	109	0	99	198	0	476
HCM Platoon Ratio	1.00	1.00	1.00	1.00	1.00	1.00	1.00	1.00	1.00	1.00	1.00	1.00
Upstream Filter(I)	1.00	0.00	1.00	1.00	1.00	1.00	1.00	0.00	1.00	1.00	0.00	1.00
Uniform Delay (d), s/veh	36.5	0.0	18.5	42.3	21.2	21.3	42.3	0.0	42.3	39.9	0.0	31.5
Incr Delay (d2), s/veh	57.8	0.0	91.3	89.1	7.5	7.7	91.6	0.0	272.5	57.2	0.0	95.1
Initial Q Delay(d3),s/veh	0.0	0.0	0.0	0.0	0.0	0.0	0.0	0.0	0.0	0.0	0.0	0.0
%ile BackOfQ(50%),veh/ln	12.1	0.0	46.1	5.0	13.0	13.3	5.2	0.0	9.7	7.3	0.0	22.5
Unsig. Movement Delay, s/veh												
LnGrp Delay(d),s/veh	94.3	0.0	109.8	131.4	28.7	29.0	133.9	0.0	314.8	97.1	0.0	126.6
LnGrp LOS	F	A	F	F	C	C	F	A	F	F	A	F
Approach Vol, veh/h		1992			1494			260			748	
Approach Delay, s/veh		104.4			36.4			237.5			119.0	
Approach LOS		F			D			F			F	
Timer - Assigned Phs	1	2		4	5	6		8				
Phs Duration (G+Y+Rc), s	9.5	57.0		14.0	21.0	45.5		9.5				
Change Period (Y+Rc), s	4.0	4.0		4.0	4.0	4.0		4.0				
Max Green Setting (Gmax), s	5.5	53.0		10.0	17.0	41.5		5.5				
Max Q Clear Time (g_c+I1), s	7.5	55.0		12.0	19.0	32.7		7.5				
Green Ext Time (p_c), s	0.0	0.0		0.0	0.0	5.5		0.0				
<b>Intersection Summary</b>												
HCM 6th Ctrl Delay				91.9								
HCM 6th LOS				F								

HCM 6th Signalized Intersection Summary  
 3: US 101 NB Off-Ramp & Shiloh Road

General Plan 2040 Project Altern. B Conditions  
 Timing Plan: P.M. Peak



Movement	EBT	EBR	WBL	WBT	NBL	NBR
Lane Configurations	↑↑			↑	↘	↗↗
Traffic Volume (veh/h)	895	0	0	1079	694	939
Future Volume (veh/h)	895	0	0	1079	694	939
Initial Q (Qb), veh	0	0	0	0	0	0
Ped-Bike Adj(A_pbT)		1.00	1.00		1.00	1.00
Parking Bus, Adj	1.00	1.00	1.00	1.00	1.00	1.00
Work Zone On Approach	No			No	No	
Adj Sat Flow, veh/h/ln	1870	0	0	1870	1870	1870
Adj Flow Rate, veh/h	952	0	0	1112	771	1043
Peak Hour Factor	0.94	0.94	0.97	0.97	0.90	0.90
Percent Heavy Veh, %	2	0	0	2	2	2
Cap, veh/h	1629	0	0	857	767	1201
Arrive On Green	0.46	0.00	0.00	0.46	0.43	0.43
Sat Flow, veh/h	3741	0	0	1870	1781	2790
Grp Volume(v), veh/h	952	0	0	1112	771	1043
Grp Sat Flow(s),veh/h/ln	1777	0	0	1870	1781	1395
Q Serve(g_s), s	14.3	0.0	0.0	33.0	31.0	24.5
Cycle Q Clear(g_c), s	14.3	0.0	0.0	33.0	31.0	24.5
Prop In Lane		0.00	0.00		1.00	1.00
Lane Grp Cap(c), veh/h	1629	0	0	857	767	1201
V/C Ratio(X)	0.58	0.00	0.00	1.30	1.01	0.87
Avail Cap(c_a), veh/h	1629	0	0	857	767	1201
HCM Platoon Ratio	1.00	1.00	1.00	1.00	1.00	1.00
Upstream Filter(I)	1.00	0.00	0.00	1.00	1.00	1.00
Uniform Delay (d), s/veh	14.4	0.0	0.0	19.5	20.5	18.6
Incr Delay (d2), s/veh	0.5	0.0	0.0	142.3	33.8	7.0
Initial Q Delay(d3),s/veh	0.0	0.0	0.0	0.0	0.0	0.0
%ile BackOfQ(50%),veh/ln	5.0	0.0	0.0	45.7	18.6	8.2
Unsig. Movement Delay, s/veh						
LnGrp Delay(d),s/veh	15.0	0.0	0.0	161.8	54.3	25.7
LnGrp LOS	B	A	A	F	F	C
Approach Vol, veh/h	952			1112	1814	
Approach Delay, s/veh	15.0			161.8	37.8	
Approach LOS	B			F	D	
Timer - Assigned Phs		2			6	8
Phs Duration (G+Y+Rc), s		37.0			37.0	35.0
Change Period (Y+Rc), s		4.0			4.0	4.0
Max Green Setting (Gmax), s		33.0			33.0	31.0
Max Q Clear Time (g_c+I1), s		16.3			35.0	33.0
Green Ext Time (p_c), s		5.9			0.0	0.0
<b>Intersection Summary</b>						
HCM 6th Ctrl Delay			67.8			
HCM 6th LOS			E			

HCM Signalized Intersection Capacity Analysis General Plan 2040 Project Altern. B Conditions  
 4: Shiloh Road & US 101 SB Off-Ramp

Timing Plan: P.M. Peak



Movement	EBL	EBT	WBT	WBR	SBL	SBR
Lane Configurations		↑	↑		↘	↘
Traffic Volume (vph)	0	659	1080	0	434	94
Future Volume (vph)	0	659	1080	0	434	94
Ideal Flow (vphpl)	1900	1900	1900	1900	1900	1900
Total Lost time (s)		4.0	4.0		4.0	4.0
Lane Util. Factor		1.00	1.00		1.00	1.00
Frbp, ped/bikes		1.00	1.00		1.00	0.98
Flpb, ped/bikes		1.00	1.00		1.00	1.00
Frt		1.00	1.00		1.00	0.85
Flt Protected		1.00	1.00		0.95	1.00
Satd. Flow (prot)		1863	1863		1770	1548
Flt Permitted		1.00	1.00		0.95	1.00
Satd. Flow (perm)		1863	1863		1770	1548
Peak-hour factor, PHF	0.89	0.89	0.96	0.96	0.93	0.93
Adj. Flow (vph)	0	740	1125	0	467	101
RTOR Reduction (vph)	0	0	0	0	0	78
Lane Group Flow (vph)	0	740	1125	0	467	23
Confl. Peds. (#/hr)						1
Turn Type		NA	NA		Perm	Perm
Protected Phases		2	6			
Permitted Phases					4	4
Actuated Green, G (s)		50.7	50.7		17.5	17.5
Effective Green, g (s)		50.7	50.7		17.5	17.5
Actuated g/C Ratio		0.67	0.67		0.23	0.23
Clearance Time (s)		4.0	4.0		4.0	4.0
Vehicle Extension (s)		3.0	3.0		3.0	3.0
Lane Grp Cap (vph)		1239	1239		406	355
v/s Ratio Prot		0.40	c0.60			
v/s Ratio Perm					c0.26	0.01
v/c Ratio		0.60	0.91		1.15	0.07
Uniform Delay, d1		7.1	10.8		29.4	23.0
Progression Factor		1.00	1.00		1.00	1.00
Incremental Delay, d2		0.8	9.7		92.4	0.1
Delay (s)		7.9	20.5		121.8	23.0
Level of Service		A	C		F	C
Approach Delay (s)		7.9	20.5		104.2	
Approach LOS		A	C		F	
<b>Intersection Summary</b>						
HCM 2000 Control Delay			36.2		HCM 2000 Level of Service	D
HCM 2000 Volume to Capacity ratio			0.97			
Actuated Cycle Length (s)			76.2		Sum of lost time (s)	8.0
Intersection Capacity Utilization			170.1%		ICU Level of Service	H
Analysis Period (min)			15			
c Critical Lane Group						

Intersection						
Int Delay, s/veh	7.9					
Movement	EBT	EBR	WBL	WBT	NBL	NBR
Lane Configurations	↑↑		↖	↑	↖	↖
Traffic Vol, veh/h	1201	16	105	1139	18	159
Future Vol, veh/h	1201	16	105	1139	18	159
Conflicting Peds, #/hr	0	0	0	0	0	0
Sign Control	Free	Free	Free	Free	Stop	Stop
RT Channelized	-	None	-	None	-	None
Storage Length	-	-	68	-	0	0
Veh in Median Storage, #	0	-	-	0	0	-
Grade, %	0	-	-	0	0	-
Peak Hour Factor	89	89	92	92	89	89
Heavy Vehicles, %	2	2	2	2	2	2
Mvmt Flow	1349	18	114	1238	20	179

Major/Minor	Major1	Major2	Minor1		
Conflicting Flow All	0	0	1367	0	2824 684
Stage 1	-	-	-	-	1358 -
Stage 2	-	-	-	-	1466 -
Critical Hdwy	-	-	4.13	-	6.63 6.93
Critical Hdwy Stg 1	-	-	-	-	5.83 -
Critical Hdwy Stg 2	-	-	-	-	5.43 -
Follow-up Hdwy	-	-	2.219	-	3.519 3.319
Pot Cap-1 Maneuver	-	-	500	-	~ 17 392
Stage 1	-	-	-	-	205 -
Stage 2	-	-	-	-	211 -
Platoon blocked, %	-	-	-	-	-
Mov Cap-1 Maneuver	-	-	500	-	~ 13 392
Mov Cap-2 Maneuver	-	-	-	-	~ 13 -
Stage 1	-	-	-	-	205 -
Stage 2	-	-	-	-	163 -



















Approach	EB	WB	NB
HCM Control Delay, s	0	1.2	107.3
HCM LOS			F

Minor Lane/Major Mvmt	NBLn1	NBLn2	EBT	EBR	WBL	WBT
Capacity (veh/h)	13	392	-	-	500	-
HCM Lane V/C Ratio	1.556	0.456	-	-	0.228	-
HCM Control Delay (s)	\$ 864.7	21.6	-	-	14.3	-
HCM Lane LOS	F	C	-	-	B	-
HCM 95th %tile Q(veh)	3.2	2.3	-	-	0.9	-

Notes  
 ~: Volume exceeds capacity    \$: Delay exceeds 300s    +: Computation Not Defined    \*: All major volume in platoon

HCM Signalized Intersection Capacity Analysis General Plan 2040 Project Altern. B Conditions  
 6: Conde Lane & Shiloh Road

Timing Plan: P.M. Peak

													
Movement	EBL	EBT	EBR	WBL	WBT	WBR	NBL	NBT	NBR	SBL	SBT	SBR	
Lane Configurations													
Traffic Volume (vph)	77	724	0	9	743	372	4	2	16	387	4	65	
Future Volume (vph)	77	724	0	9	743	372	4	2	16	387	4	65	
Ideal Flow (vphp)	1900	1900	1900	1900	1900	1900	1900	1900	1900	1900	1900	1900	
Total Lost time (s)	4.0	4.0		4.0	4.0			4.0			4.0	4.0	
Lane Util. Factor	1.00	0.95		1.00	0.95			1.00			1.00	1.00	
Frbp, ped/bikes	1.00	1.00		1.00	0.99			1.00			1.00	1.00	
Flpb, ped/bikes	1.00	1.00		1.00	1.00			1.00			1.00	1.00	
Frt	1.00	1.00		1.00	0.95			0.90			1.00	0.85	
Flt Protected	0.95	1.00		0.95	1.00			0.99			0.95	1.00	
Satd. Flow (prot)	1770	3539		1770	3339			1663			1775	1583	
Flt Permitted	0.95	1.00		0.95	1.00			0.99			0.95	1.00	
Satd. Flow (perm)	1770	3539		1770	3339			1663			1775	1583	
Peak-hour factor, PHF	0.88	0.88	0.88	0.80	0.80	0.80	0.63	0.63	0.63	0.88	0.88	0.88	
Adj. Flow (vph)	88	823	0	11	929	465	6	3	25	440	5	74	
RTOR Reduction (vph)	0	0	0	0	42	0	0	23	0	0	0	0	
Lane Group Flow (vph)	88	823	0	11	1352	0	0	11	0	0	445	74	
Confl. Peds. (#/hr)	1					1							
Turn Type	Prot	NA		Prot	NA		Split	NA		Split	NA	custom	
Protected Phases	5	2		1	6		7	7		4	4		
Permitted Phases												6	
Actuated Green, G (s)	6.6	49.4		1.4	44.2			5.4			11.2	44.2	
Effective Green, g (s)	6.6	49.4		1.4	44.2			5.4			11.2	44.2	
Actuated g/C Ratio	0.08	0.59		0.02	0.53			0.06			0.13	0.53	
Clearance Time (s)	4.0	4.0		4.0	4.0			4.0			4.0	4.0	
Vehicle Extension (s)	3.0	3.0		3.0	3.0			3.0			3.0	3.0	
Lane Grp Cap (vph)	140	2096		29	1769			107			238	838	
v/s Ratio Prot	c0.05	0.23		0.01	c0.40			c0.01			c0.25		
v/s Ratio Perm												0.05	
v/c Ratio	0.63	0.39		0.38	0.76			0.10			1.87	0.09	
Uniform Delay, d1	37.2	9.0		40.6	15.5			36.7			36.1	9.7	
Progression Factor	1.00	1.00		1.00	1.00			1.00			1.00	1.00	
Incremental Delay, d2	8.5	0.1		8.1	2.0			0.4			407.0	0.0	
Delay (s)	45.7	9.2		48.7	17.5			37.1			443.1	9.7	
Level of Service	D	A		D	B			D			F	A	
Approach Delay (s)		12.7			17.7			37.1			381.3		
Approach LOS		B			B			D			F		
<b>Intersection Summary</b>													
HCM 2000 Control Delay			82.1									HCM 2000 Level of Service	F
HCM 2000 Volume to Capacity ratio			0.88										
Actuated Cycle Length (s)			83.4									Sum of lost time (s)	16.0
Intersection Capacity Utilization			77.5%									ICU Level of Service	D
Analysis Period (min)			15										
c Critical Lane Group													

Intersection												
Int Delay, s/veh	2.7											
Movement	EBL	EBT	EBR	WBL	WBT	WBR	NBL	NBT	NBR	SBL	SBT	SBR
Lane Configurations		↕	↕		↕		↕	↕			↕	
Traffic Vol, veh/h	25	385	76	0	401	0	71	0	0	0	0	21
Future Vol, veh/h	25	385	76	0	401	0	71	0	0	0	0	21
Conflicting Peds, #/hr	1	0	0	0	0	0	0	0	0	0	0	0
Sign Control	Free	Free	Free	Free	Free	Free	Stop	Stop	Stop	Stop	Stop	Stop
RT Channelized	-	-	None	-	-	None	-	-	None	-	-	None
Storage Length	-	-	150	-	-	-	0	-	-	-	-	-
Veh in Median Storage, #	-	0	-	-	0	-	-	0	-	-	0	-
Grade, %	-	0	-	-	0	-	-	0	-	-	0	-
Peak Hour Factor	94	94	94	69	69	69	100	100	100	58	58	58
Heavy Vehicles, %	2	2	2	2	2	2	2	2	2	2	2	2
Mvmt Flow	27	410	81	0	581	0	71	0	0	0	0	36

Major/Minor	Major1			Major2			Minor1			Minor2		
Conflicting Flow All	582	0	0	491	0	0	1063	1046	410	1087	1127	582
Stage 1	-	-	-	-	-	-	464	464	-	582	582	-
Stage 2	-	-	-	-	-	-	599	582	-	505	545	-
Critical Hdwy	4.12	-	-	4.12	-	-	7.12	6.52	6.22	7.12	6.52	6.22
Critical Hdwy Stg 1	-	-	-	-	-	-	6.12	5.52	-	6.12	5.52	-
Critical Hdwy Stg 2	-	-	-	-	-	-	6.12	5.52	-	6.12	5.52	-
Follow-up Hdwy	2.218	-	-	2.218	-	-	3.518	4.018	3.318	3.518	4.018	3.318
Pot Cap-1 Maneuver	992	-	-	1072	-	-	201	228	642	194	205	513
Stage 1	-	-	-	-	-	-	578	564	-	499	499	-
Stage 2	-	-	-	-	-	-	488	499	-	549	519	-
Platoon blocked, %		-	-		-	-						
Mov Cap-1 Maneuver	991	-	-	1072	-	-	181	219	642	188	197	513
Mov Cap-2 Maneuver	-	-	-	-	-	-	181	219	-	188	197	-
Stage 1	-	-	-	-	-	-	556	543	-	480	499	-
Stage 2	-	-	-	-	-	-	454	499	-	528	499	-

Approach	EB	WB	NB	SB
HCM Control Delay, s	0.4	0	37.2	12.6
HCM LOS			E	B

Minor Lane/Major Mvmt	NBLn1	NBLn2	EBL	EBT	EBR	WBL	WBT	WBR	SBLn1
Capacity (veh/h)	181	-	991	-	-	1072	-	-	513
HCM Lane V/C Ratio	0.392	-	0.027	-	-	-	-	-	0.071
HCM Control Delay (s)	37.2	0	8.7	0	-	0	-	-	12.6
HCM Lane LOS	E	A	A	A	-	A	-	-	B
HCM 95th %tile Q(veh)	1.7	-	0.1	-	-	0	-	-	0.2



Intersection												
Int Delay, s/veh	30.4											
Movement	EBL	EBT	EBR	WBL	WBT	WBR	NBL	NBT	NBR	SBL	SBT	SBR
Lane Configurations		↕		↕	↕			↕	↕	↕	↕	
Traffic Vol, veh/h	4	0	0	41	0	66	0	1195	45	72	1152	0
Future Vol, veh/h	4	0	0	41	0	66	0	1195	45	72	1152	0
Conflicting Peds, #/hr	0	0	0	0	0	0	0	0	0	0	0	0
Sign Control	Stop	Stop	Stop	Stop	Stop	Stop	Free	Free	Free	Free	Free	Free
RT Channelized	-	-	None	-	-	None	-	-	None	-	-	None
Storage Length	-	-	-	0	-	-	-	-	100	50	-	-
Veh in Median Storage, #	-	0	-	-	0	-	-	0	-	-	0	-
Grade, %	-	0	-	-	0	-	-	0	-	-	0	-
Peak Hour Factor	38	38	38	100	100	100	91	91	91	94	94	94
Heavy Vehicles, %	2	2	2	2	2	2	2	2	2	2	2	2
Mvmt Flow	11	0	0	41	0	66	0	1313	49	77	1226	0

Major/Minor	Minor2		Minor1		Major1		Major2					
Conflicting Flow All	2751	2742	1226	2693	2693	1313	1226	0	0	1362	0	0
Stage 1	1380	1380	-	1313	1313	-	-	-	-	-	-	-
Stage 2	1371	1362	-	1380	1380	-	-	-	-	-	-	-
Critical Hdwy	7.12	6.52	6.22	7.12	6.52	6.22	4.12	-	-	4.12	-	-
Critical Hdwy Stg 1	6.12	5.52	-	6.12	5.52	-	-	-	-	-	-	-
Critical Hdwy Stg 2	6.12	5.52	-	6.12	5.52	-	-	-	-	-	-	-
Follow-up Hdwy	3.518	4.018	3.318	3.518	4.018	3.318	2.218	-	-	2.218	-	-
Pot Cap-1 Maneuver	13	20	218	~ 14	22	194	569	-	-	505	-	-
Stage 1	178	212	-	195	228	-	-	-	-	-	-	-
Stage 2	181	216	-	178	212	-	-	-	-	-	-	-
Platoon blocked, %								-	-	-	-	-
Mov Cap-1 Maneuver	~ 8	17	218	~ 12	19	194	569	-	-	505	-	-
Mov Cap-2 Maneuver	~ 8	17	-	~ 12	19	-	-	-	-	-	-	-
Stage 1	178	180	-	195	228	-	-	-	-	-	-	-
Stage 2	119	216	-	151	180	-	-	-	-	-	-	-

Approach	EB		WB		NB		SB	
HCM Control Delay, \$	1047.1		678.8		0		0.8	
HCM LOS	F		F					

Minor Lane/Major Mvmt	NBL	NBT	NBR	EBLn1	WBLn1	WBLn2	SBL	SBT	SBR
Capacity (veh/h)	569	-	-	8	12	194	505	-	-
HCM Lane V/C Ratio	-	-	-	1.316	3.417	0.34	0.152	-	-
HCM Control Delay (s)	0	-	-	\$ 1047	\$ 1718.8	32.8	13.4	-	-
HCM Lane LOS	A	-	-	F	F	D	B	-	-
HCM 95th %tile Q(veh)	0	-	-	2.2	6.1	1.4	0.5	-	-

Notes  
 ~: Volume exceeds capacity    \$: Delay exceeds 300s    +: Computation Not Defined    \*: All major volume in platoon

Intersection						
Int Delay, s/veh	4.2					
Movement	EBT	EBR	WBL	WBT	NBL	NBR
Lane Configurations	↑	↗		↖	↖	↗
Traffic Vol, veh/h	120	233	22	164	216	21
Future Vol, veh/h	120	233	22	164	216	21
Conflicting Peds, #/hr	0	0	0	0	0	0
Sign Control	Free	Free	Free	Free	Stop	Stop
RT Channelized	-	None	-	None	-	None
Storage Length	-	200	-	-	0	0
Veh in Median Storage, #	0	-	-	0	0	-
Grade, %	0	-	-	0	0	-
Peak Hour Factor	92	92	68	68	100	100
Heavy Vehicles, %	2	2	2	2	2	2
Mvmt Flow	130	253	32	241	216	21

Major/Minor	Major1	Major2	Minor1		
Conflicting Flow All	0	0	383	0	435
Stage 1	-	-	-	-	130
Stage 2	-	-	-	-	305
Critical Hdwy	-	-	4.12	-	6.42
Critical Hdwy Stg 1	-	-	-	-	5.42
Critical Hdwy Stg 2	-	-	-	-	5.42
Follow-up Hdwy	-	-	2.218	-	3.518
Pot Cap-1 Maneuver	-	-	1175	-	578
Stage 1	-	-	-	-	896
Stage 2	-	-	-	-	748
Platoon blocked, %	-	-	-	-	-
Mov Cap-1 Maneuver	-	-	1175	-	560
Mov Cap-2 Maneuver	-	-	-	-	560
Stage 1	-	-	-	-	896
Stage 2	-	-	-	-	725

Approach	EB	WB	NB
HCM Control Delay, s	0	1	14.8
HCM LOS			B

Minor Lane/Major Mvmt	NBLn1	NBLn2	EBT	EBR	WBL	WBT
Capacity (veh/h)	560	920	-	-	1175	-
HCM Lane V/C Ratio	0.386	0.023	-	-	0.028	-
HCM Control Delay (s)	15.4	9	-	-	8.2	0
HCM Lane LOS	C	A	-	-	A	A
HCM 95th %tile Q(veh)	1.8	0.1	-	-	0.1	-

HCM 6th Signalized Intersection Summary      General Plan 2040 Project Altern. B Conditions  
 10: US 101 NB Off Ramp/Lakewood Drive & Old Redwood Highway      Timing Plan: P.M. Peak

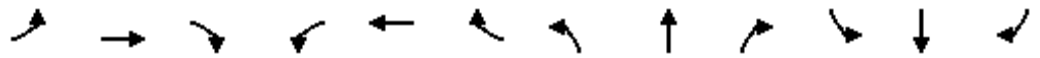

Movement	EBL	EBT	EBR	WBL	WBT	WBR	NBL	NBT	NBR	SBL	SBT	SBR
Lane Configurations	↔↔	↑			↑↑		↔	↔↔		↔↔		↔
Traffic Volume (veh/h)	309	717	0	0	756	270	528	539	303	386	0	618
Future Volume (veh/h)	309	717	0	0	756	270	528	539	303	386	0	618
Initial Q (Qb), veh	0	0	0	0	0	0	0	0	0	0	0	0
Ped-Bike Adj(A_pbT)	1.00		1.00	1.00		0.98	1.00		0.99	1.00		1.00
Parking Bus, Adj	1.00	1.00	1.00	1.00	1.00	1.00	1.00	1.00	1.00	1.00	1.00	1.00
Work Zone On Approach		No			No			No			No	
Adj Sat Flow, veh/h/ln	1870	1870	0	0	1870	1870	1870	1870	1870	1870	0	1870
Adj Flow Rate, veh/h	355	824	0	0	831	297	496	695	329	402	0	0
Peak Hour Factor	0.87	0.87	0.87	0.91	0.91	0.91	0.92	0.92	0.92	0.96	0.96	0.96
Percent Heavy Veh, %	2	2	0	0	2	2	2	2	2	2	0	2
Cap, veh/h	404	978	0	0	902	322	623	838	396	0	0	0
Arrive On Green	0.12	0.52	0.00	0.00	0.35	0.35	0.35	0.35	0.35	0.00	0.00	0.00
Sat Flow, veh/h	3456	1870	0	0	2645	910	1781	2394	1133		0	
Grp Volume(v), veh/h	355	824	0	0	578	550	496	543	481		0.0	
Grp Sat Flow(s),veh/h/ln	1728	1870	0	0	1777	1684	1781	1870	1657			
Q Serve(g_s), s	7.8	28.9	0.0	0.0	24.0	24.1	19.3	20.4	20.5			
Cycle Q Clear(g_c), s	7.8	28.9	0.0	0.0	24.0	24.1	19.3	20.4	20.5			
Prop In Lane	1.00		0.00	0.00		0.54	1.00		0.68			
Lane Grp Cap(c), veh/h	404	978	0	0	628	596	623	654	580			
V/C Ratio(X)	0.88	0.84	0.00	0.00	0.92	0.92	0.80	0.83	0.83			
Avail Cap(c_a), veh/h	404	978	0	0	628	596	672	705	625			
HCM Platoon Ratio	1.00	1.00	1.00	1.00	1.00	1.00	1.00	1.00	1.00			
Upstream Filter(I)	1.00	1.00	0.00	0.00	1.00	1.00	1.00	1.00	1.00			
Uniform Delay (d), s/veh	33.4	15.7	0.0	0.0	23.8	23.8	22.5	22.9	22.9			
Incr Delay (d2), s/veh	19.2	8.8	0.0	0.0	20.9	22.0	6.2	7.8	8.7			
Initial Q Delay(d3),s/veh	0.0	0.0	0.0	0.0	0.0	0.0	0.0	0.0	0.0			
%ile BackOfQ(50%),veh/ln	4.2	12.8	0.0	0.0	12.8	12.4	8.6	9.8	8.9			
Unsig. Movement Delay, s/veh												
LnGrp Delay(d),s/veh	52.6	24.4	0.0	0.0	44.7	45.9	28.8	30.7	31.6			
LnGrp LOS	D	C	A	A	D	D	C	C	C			
Approach Vol, veh/h		1179			1128			1520				
Approach Delay, s/veh		32.9			45.3			30.3				
Approach LOS		C			D			C				
Timer - Assigned Phs		2			5	6		8				
Phs Duration (G+Y+Rc), s		45.3			13.0	32.3		31.6				
Change Period (Y+Rc), s		5.1			4.0	5.1		4.7				
Max Green Setting (Gmax), s		40.2			9.0	27.2		29.0				
Max Q Clear Time (g_c+I1), s		30.9			9.8	26.1		22.5				
Green Ext Time (p_c), s		3.9			0.0	0.8		4.3				

**Intersection Summary**

HCM 6th Ctrl Delay	35.5
HCM 6th LOS	D

**Notes**

User approved volume balancing among the lanes for turning movement.  
 Unsignalized Delay for [SBR] is excluded from calculations of the approach delay and intersection delay.

HCM 6th Signalized Intersection Summary      General Plan 2040 Project Altern. B Conditions  
 12: US 101 SB On Ramp/US 101 SB Off Ramp & Old Redwood Highway      Timing Plan: P.M. Peak

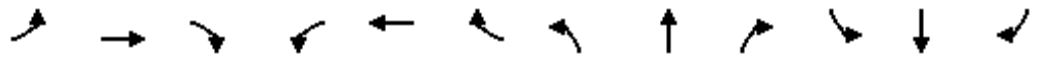

Movement	EBL	EBT	EBR	WBL	WBT	WBR	NBL	NBT	NBR	SBL	SBT	SBR
Lane Configurations		↑↑	↗	↘	↑↑					↘	↕	
Traffic Volume (veh/h)	0	612	501	443	1121	0	0	0	0	346	2	221
Future Volume (veh/h)	0	612	501	443	1121	0	0	0	0	346	2	221
Initial Q (Qb), veh	0	0	0	0	0	0				0	0	0
Ped-Bike Adj(A_pbT)	1.00		0.98	1.00		1.00				1.00		1.00
Parking Bus, Adj	1.00	1.00	1.00	1.00	1.00	1.00				1.00	1.00	1.00
Work Zone On Approach		No			No						No	
Adj Sat Flow, veh/h/ln	0	1870	1870	1870	1870	0				1870	1870	1870
Adj Flow Rate, veh/h	0	651	533	498	1260	0				342	106	0
Peak Hour Factor	0.94	0.94	0.94	0.89	0.89	0.89				0.83	0.83	0.83
Percent Heavy Veh, %	0	2	2	2	2	0				2	2	2
Cap, veh/h	0	1416	622	458	2533	0				262	275	
Arrive On Green	0.00	0.40	0.40	0.26	0.71	0.00				0.15	0.15	0.00
Sat Flow, veh/h	0	3647	1560	1781	3647	0				1781	1870	0
Grp Volume(v), veh/h	0	651	533	498	1260	0				342	106	0
Grp Sat Flow(s),veh/h/ln	0	1777	1560	1781	1777	0				1781	1870	0
Q Serve(g_s), s	0.0	9.4	21.8	18.0	11.0	0.0				10.3	3.6	0.0
Cycle Q Clear(g_c), s	0.0	9.4	21.8	18.0	11.0	0.0				10.3	3.6	0.0
Prop In Lane	0.00		1.00	1.00		0.00				1.00		0.00
Lane Grp Cap(c), veh/h	0	1416	622	458	2533	0				262	275	
V/C Ratio(X)	0.00	0.46	0.86	1.09	0.50	0.00				1.30	0.39	
Avail Cap(c_a), veh/h	0	1416	622	458	2533	0				262	275	
HCM Platoon Ratio	1.00	1.00	1.00	1.00	1.00	1.00				1.00	1.00	1.00
Upstream Filter(I)	0.00	1.00	1.00	1.00	1.00	0.00				1.00	1.00	0.00
Uniform Delay (d), s/veh	0.0	15.5	19.2	26.0	4.5	0.0				29.8	27.0	0.0
Incr Delay (d2), s/veh	0.0	1.1	14.2	67.7	0.7	0.0				162.1	0.9	0.0
Initial Q Delay(d3),s/veh	0.0	0.0	0.0	0.0	0.0	0.0				0.0	0.0	0.0
%ile BackOfQ(50%),veh/ln	0.0	3.6	9.4	15.6	2.6	0.0				16.0	1.6	0.0
Unsig. Movement Delay, s/veh												
LnGrp Delay(d),s/veh	0.0	16.6	33.5	93.7	5.2	0.0				191.9	27.9	0.0
LnGrp LOS	A	B	C	F	A	A				F	C	
Approach Vol, veh/h		1184			1758						448	
Approach Delay, s/veh		24.2			30.2						153.1	
Approach LOS		C			C						F	
Timer - Assigned Phs		2			5	6		8				
Phs Duration (G+Y+Rc), s		55.0			22.0	33.0		15.0				
Change Period (Y+Rc), s		5.1			4.0	5.1		4.7				
Max Green Setting (Gmax), s		49.9			18.0	27.9		10.3				
Max Q Clear Time (g_c+I1), s		13.0			20.0	23.8		12.3				
Green Ext Time (p_c), s		11.9			0.0	2.3		0.0				

**Intersection Summary**

HCM 6th Ctrl Delay	44.4
HCM 6th LOS	D

**Notes**

- User approved volume balancing among the lanes for turning movement.
- User approved ignoring U-Turning movement.
- Unsignalized Delay for [SBR] is excluded from calculations of the approach delay and intersection delay.

HCM 6th Signalized Intersection Summary  
1: Old Redwood Hwy & Shiloh Road

General Plan 2040 Project Altern. B Conditions  
Timing Plan: Saturday Midday Peak

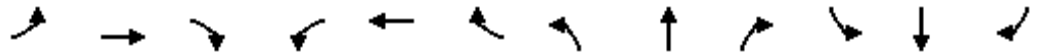

Movement	EBL	EBT	EBR	WBL	WBT	WBR	NBL	NBT	NBR	SBL	SBT	SBR
Lane Configurations												
Traffic Volume (veh/h)	182	475	301	31	510	76	314	351	35	79	284	266
Future Volume (veh/h)	182	475	301	31	510	76	314	351	35	79	284	266
Initial Q (Qb), veh	0	0	0	0	0	0	0	0	0	0	0	0
Ped-Bike Adj(A_pbT)	1.00		0.97	1.00		1.00	1.00		0.98	1.00		0.97
Parking Bus, Adj	1.00	1.00	1.00	1.00	1.00	1.00	1.00	1.00	1.00	1.00	1.00	1.00
Work Zone On Approach		No			No			No			No	
Adj Sat Flow, veh/h/ln	1870	1870	1870	1870	1870	1870	1870	1870	1870	1870	1870	1870
Adj Flow Rate, veh/h	204	534	338	36	593	88	338	377	38	87	312	292
Peak Hour Factor	0.89	0.89	0.89	0.86	0.86	0.86	0.93	0.93	0.93	0.91	0.91	0.91
Percent Heavy Veh, %	2	2	2	2	2	2	2	2	2	2	2	2
Cap, veh/h	426	448	368	32	524	473	196	527	437	77	402	331
Arrive On Green	0.24	0.24	0.24	0.30	0.30	0.30	0.11	0.28	0.28	0.04	0.22	0.22
Sat Flow, veh/h	1781	1870	1538	107	1758	1585	1781	1870	1551	1781	1870	1540
Grp Volume(v), veh/h	204	534	338	629	0	88	338	377	38	87	312	292
Grp Sat Flow(s),veh/h/ln	1781	1870	1538	1865	0	1585	1781	1870	1551	1781	1870	1540
Q Serve(g_s), s	12.5	30.5	27.3	38.0	0.0	5.3	14.0	23.1	2.3	5.5	20.0	23.4
Cycle Q Clear(g_c), s	12.5	30.5	27.3	38.0	0.0	5.3	14.0	23.1	2.3	5.5	20.0	23.4
Prop In Lane	1.00		1.00	0.06		1.00	1.00		1.00	1.00		1.00
Lane Grp Cap(c), veh/h	426	448	368	556	0	473	196	527	437	77	402	331
V/C Ratio(X)	0.48	1.19	0.92	1.13	0.00	0.19	1.73	0.72	0.09	1.13	0.78	0.88
Avail Cap(c_a), veh/h	426	448	368	556	0	473	196	639	530	77	514	423
HCM Platoon Ratio	1.00	1.00	1.00	1.00	1.00	1.00	1.00	1.00	1.00	1.00	1.00	1.00
Upstream Filter(I)	1.00	1.00	1.00	1.00	0.00	1.00	1.00	1.00	1.00	1.00	1.00	1.00
Uniform Delay (d), s/veh	41.6	48.5	47.2	44.7	0.0	33.2	56.7	41.2	33.7	61.0	47.1	48.4
Incr Delay (d2), s/veh	0.8	106.9	27.4	79.5	0.0	0.2	347.6	3.0	0.1	142.7	5.6	16.0
Initial Q Delay(d3),s/veh	0.0	0.0	0.0	0.0	0.0	0.0	0.0	0.0	0.0	0.0	0.0	0.0
%ile BackOfQ(50%),veh/ln	5.5	27.2	12.9	29.3	0.0	2.0	25.0	10.7	0.9	5.5	9.8	10.3
Unsig. Movement Delay, s/veh												
LnGrp Delay(d),s/veh	42.5	155.3	74.6	124.2	0.0	33.4	404.3	44.2	33.8	203.6	52.7	64.5
LnGrp LOS	D	F	E	F	A	C	F	D	C	F	D	E
Approach Vol, veh/h		1076			717			753			691	
Approach Delay, s/veh		108.6			113.1			205.3			76.7	
Approach LOS		F			F			F			E	
Timer - Assigned Phs		2	3	4		6	7	8				
Phs Duration (G+Y+Rc), s		35.0	18.0	31.9		42.5	9.5	40.4				
Change Period (Y+Rc), s		4.5	4.0	4.5		4.5	4.0	4.5				
Max Green Setting (Gmax), s		30.5	14.0	35.0		38.0	5.5	43.5				
Max Q Clear Time (g_c+I1), s		32.5	16.0	25.4		40.0	7.5	25.1				
Green Ext Time (p_c), s		0.0	0.0	2.0		0.0	0.0	2.0				
<b>Intersection Summary</b>												
HCM 6th Ctrl Delay				125.3								
HCM 6th LOS				F								

HCM 6th Signalized Intersection Summary  
2: Shiloh Road & Hembree Ln

General Plan 2040 Project Altern. B Conditions  
Timing Plan: Saturday Midday Peak



Movement	EBL	EBT	EBR	WBL	WBT	WBR	NBL	NBT	NBR	SBL	SBT	SBR
Lane Configurations	↔↔	↔		↔	↔↔		↔	↔			↔	↔
Traffic Volume (veh/h)	918	827	69	110	796	235	110	21	128	236	11	856
Future Volume (veh/h)	918	827	69	110	796	235	110	21	128	236	11	856
Initial Q (Qb), veh	0	0	0	0	0	0	0	0	0	0	0	0
Ped-Bike Adj(A_pbT)	1.00		1.00	1.00		1.00	1.00		1.00	1.00		1.00
Parking Bus, Adj	1.00	1.00	1.00	1.00	1.00	1.00	1.00	1.00	1.00	1.00	1.00	1.00
Work Zone On Approach		No			No			No			No	
Adj Sat Flow, veh/h/ln	1870	1870	1870	1870	1870	1870	1870	1870	1870	1870	1870	1870
Adj Flow Rate, veh/h	977	880	69	110	829	245	110	21	128	259	11	941
Peak Hour Factor	0.94	0.94	1.00	1.00	0.96	0.96	1.00	1.00	1.00	0.91	1.00	0.91
Percent Heavy Veh, %	2	2	2	2	2	2	2	2	2	2	2	2
Cap, veh/h	703	953	75	117	1134	335	117	15	92	205	9	512
Arrive On Green	0.20	0.56	0.56	0.07	0.42	0.42	0.07	0.07	0.07	0.12	0.12	0.12
Sat Flow, veh/h	3456	1712	134	1781	2704	799	1781	228	1392	1712	73	1585
Grp Volume(v), veh/h	977	0	949	110	545	529	110	0	149	270	0	941
Grp Sat Flow(s),veh/h/ln	1728	0	1846	1781	1777	1726	1781	0	1620	1785	0	1585
Q Serve(g_s), s	17.0	0.0	39.1	5.1	21.4	21.5	5.1	0.0	5.5	10.0	0.0	10.0
Cycle Q Clear(g_c), s	17.0	0.0	39.1	5.1	21.4	21.5	5.1	0.0	5.5	10.0	0.0	10.0
Prop In Lane	1.00		0.07	1.00		0.46	1.00		0.86	0.96		1.00
Lane Grp Cap(c), veh/h	703	0	1028	117	745	724	117	0	107	214	0	512
V/C Ratio(X)	1.39	0.00	0.92	0.94	0.73	0.73	0.94	0.00	1.40	1.26	0.00	1.84
Avail Cap(c_a), veh/h	703	0	1172	117	883	858	117	0	107	214	0	512
HCM Platoon Ratio	1.00	1.00	1.00	1.00	1.00	1.00	1.00	1.00	1.00	1.00	1.00	1.00
Upstream Filter(I)	1.00	0.00	1.00	1.00	1.00	1.00	1.00	0.00	1.00	1.00	0.00	1.00
Uniform Delay (d), s/veh	33.3	0.0	16.9	38.8	20.3	20.3	38.8	0.0	39.0	36.8	0.0	28.3
Incr Delay (d2), s/veh	183.7	0.0	11.1	63.7	2.6	2.7	63.7	0.0	225.5	150.4	0.0	383.9
Initial Q Delay(d3),s/veh	0.0	0.0	0.0	0.0	0.0	0.0	0.0	0.0	0.0	0.0	0.0	0.0
%ile BackOfQ(50%),veh/ln	24.6	0.0	16.7	4.2	8.5	8.3	4.3	0.0	8.8	13.1	0.0	64.3
Unsig. Movement Delay, s/veh												
LnGrp Delay(d),s/veh	216.9	0.0	28.0	102.5	22.9	23.0	102.5	0.0	264.5	187.1	0.0	412.1
LnGrp LOS	F	A	C	F	C	C	F	A	F	F	A	F
Approach Vol, veh/h		1926			1184			259				1211
Approach Delay, s/veh		123.8			30.3			195.7				361.9
Approach LOS		F			C			F				F
Timer - Assigned Phs	1	2		4	5	6		8				
Phs Duration (G+Y+Rc), s	9.5	50.5		14.0	21.0	39.0		9.5				
Change Period (Y+Rc), s	4.0	4.0		4.0	4.0	4.0		4.0				
Max Green Setting (Gmax), s	5.5	53.0		10.0	17.0	41.5		5.5				
Max Q Clear Time (g_c+I1), s	7.1	41.1		12.0	19.0	23.5		7.5				
Green Ext Time (p_c), s	0.0	5.4		0.0	0.0	6.5		0.0				

Intersection Summary

HCM 6th Ctrl Delay	166.7
HCM 6th LOS	F

HCM 6th Signalized Intersection Summary  
 3: US 101 NB Off-Ramp & Shiloh Road

General Plan 2040 Project Altern. B Conditions  
 Timing Plan: Saturday Midday Peak



Movement	EBT	EBR	WBL	WBT	NBL	NBR
Lane Configurations	↑↑			↑	↵	↵↵
Traffic Volume (veh/h)	705	0	0	1233	520	1038
Future Volume (veh/h)	705	0	0	1233	520	1038
Initial Q (Qb), veh	0	0	0	0	0	0
Ped-Bike Adj(A_pbT)		1.00	1.00		1.00	1.00
Parking Bus, Adj	1.00	1.00	1.00	1.00	1.00	1.00
Work Zone On Approach	No			No	No	
Adj Sat Flow, veh/h/ln	1870	0	0	1870	1870	1870
Adj Flow Rate, veh/h	775	0	0	1385	547	1093
Peak Hour Factor	0.91	0.91	0.89	0.89	0.95	0.95
Percent Heavy Veh, %	2	0	0	2	2	2
Cap, veh/h	1616	0	0	850	747	1170
Arrive On Green	0.45	0.00	0.00	0.45	0.42	0.42
Sat Flow, veh/h	3741	0	0	1870	1781	2790
Grp Volume(v), veh/h	775	0	0	1385	547	1093
Grp Sat Flow(s),veh/h/ln	1777	0	0	1870	1781	1395
Q Serve(g_s), s	10.9	0.0	0.0	32.5	18.4	26.7
Cycle Q Clear(g_c), s	10.9	0.0	0.0	32.5	18.4	26.7
Prop In Lane		0.00	0.00		1.00	1.00
Lane Grp Cap(c), veh/h	1616	0	0	850	747	1170
V/C Ratio(X)	0.48	0.00	0.00	1.63	0.73	0.93
Avail Cap(c_a), veh/h	1616	0	0	850	760	1190
HCM Platoon Ratio	1.00	1.00	1.00	1.00	1.00	1.00
Upstream Filter(I)	1.00	0.00	0.00	1.00	1.00	1.00
Uniform Delay (d), s/veh	13.6	0.0	0.0	19.5	17.4	19.8
Incr Delay (d2), s/veh	0.2	0.0	0.0	288.3	3.6	13.2
Initial Q Delay(d3),s/veh	0.0	0.0	0.0	0.0	0.0	0.0
%ile BackOfQ(50%),veh/ln	3.8	0.0	0.0	79.8	7.6	9.9
Unsig. Movement Delay, s/veh						
LnGrp Delay(d),s/veh	13.8	0.0	0.0	307.8	21.0	33.0
LnGrp LOS	B	A	A	F	C	C
Approach Vol, veh/h	775			1385	1640	
Approach Delay, s/veh	13.8			307.8	29.0	
Approach LOS	B			F	C	
Timer - Assigned Phs		2			6	8
Phs Duration (G+Y+Rc), s		37.0			37.0	34.5
Change Period (Y+Rc), s		4.5			4.5	4.5
Max Green Setting (Gmax), s		32.5			32.5	30.5
Max Q Clear Time (g_c+I1), s		12.9			34.5	28.7
Green Ext Time (p_c), s		5.0			0.0	1.2

Intersection Summary

HCM 6th Ctrl Delay	127.5
HCM 6th LOS	F

# HCM Signalized Intersection Capacity Analysis General Plan 2040 Project Altern. B Conditions

## 4: Shiloh Road & US 101 SB Off-Ramp

Timing Plan: Saturday Midday Peak



Movement	EBL	EBT	WBT	WBR	SBL	SBR
Lane Configurations		↑	↑		↘	↘
Traffic Volume (vph)	0	421	793	0	400	223
Future Volume (vph)	0	421	793	0	400	223
Ideal Flow (vphpl)	1900	1900	1900	1900	1900	1900
Total Lost time (s)		4.5	4.5		4.5	4.5
Lane Util. Factor		1.00	1.00		1.00	1.00
Frbp, ped/bikes		1.00	1.00		1.00	1.00
Flpb, ped/bikes		1.00	1.00		1.00	1.00
Frt		1.00	1.00		1.00	0.85
Flt Protected		1.00	1.00		0.95	1.00
Satd. Flow (prot)		1863	1863		1770	1583
Flt Permitted		1.00	1.00		0.95	1.00
Satd. Flow (perm)		1863	1863		1770	1583
Peak-hour factor, PHF	0.96	0.96	0.96	0.96	0.68	0.68
Adj. Flow (vph)	0	439	826	0	588	328
RTOR Reduction (vph)	0	0	0	0	0	170
Lane Group Flow (vph)	0	439	826	0	588	158
Confl. Bikes (#/hr)				2		
Turn Type		NA	NA		Perm	Perm
Protected Phases		2	6			
Permitted Phases					4	4
Actuated Green, G (s)		30.7	30.7		16.9	16.9
Effective Green, g (s)		30.7	30.7		16.9	16.9
Actuated g/C Ratio		0.54	0.54		0.30	0.30
Clearance Time (s)		4.5	4.5		4.5	4.5
Vehicle Extension (s)		3.0	3.0		3.0	3.0
Lane Grp Cap (vph)		1010	1010		528	472
v/s Ratio Prot		0.24	c0.44			
v/s Ratio Perm					c0.33	0.10
v/c Ratio		0.43	0.82		1.11	0.33
Uniform Delay, d1		7.8	10.7		19.9	15.5
Progression Factor		1.00	1.00		1.00	1.00
Incremental Delay, d2		0.3	5.2		74.2	0.4
Delay (s)		8.1	15.9		94.0	15.9
Level of Service		A	B		F	B
Approach Delay (s)		8.1	15.9		66.0	
Approach LOS		A	B		E	
<b>Intersection Summary</b>						
HCM 2000 Control Delay			35.4		HCM 2000 Level of Service	D
HCM 2000 Volume to Capacity ratio			0.92			
Actuated Cycle Length (s)			56.6		Sum of lost time (s)	9.0
Intersection Capacity Utilization			154.9%		ICU Level of Service	H
Analysis Period (min)			15			
c Critical Lane Group						



Intersection						
Int Delay, s/veh	5.8					
Movement	EBT	EBR	WBL	WBT	NBL	NBR
Lane Configurations	↑↑		↘	↑	↘	↘
Traffic Vol, veh/h	823	30	120	910	24	115
Future Vol, veh/h	823	30	120	910	24	115
Conflicting Peds, #/hr	0	0	0	0	1	0
Sign Control	Free	Free	Free	Free	Stop	Stop
RT Channelized	-	None	-	None	-	None
Storage Length	-	-	68	-	0	0
Veh in Median Storage, #	0	-	-	0	0	-
Grade, %	0	-	-	0	0	-
Peak Hour Factor	92	92	87	87	78	78
Heavy Vehicles, %	2	2	2	2	2	2
Mvmt Flow	895	33	138	1046	31	147



















Major/Minor	Major1	Major2	Minor1		
Conflicting Flow All	0	0	928	0	2235 464
Stage 1	-	-	-	-	912 -
Stage 2	-	-	-	-	1323 -
Critical Hdwy	-	-	4.13	-	6.63 6.93
Critical Hdwy Stg 1	-	-	-	-	5.83 -
Critical Hdwy Stg 2	-	-	-	-	5.43 -
Follow-up Hdwy	-	-	2.219	-	3.519 3.319
Pot Cap-1 Maneuver	-	-	735	-	41 546
Stage 1	-	-	-	-	353 -
Stage 2	-	-	-	-	248 -
Platoon blocked, %	-	-	-	-	-
Mov Cap-1 Maneuver	-	-	735	-	33 546
Mov Cap-2 Maneuver	-	-	-	-	33 -
Stage 1	-	-	-	-	353 -
Stage 2	-	-	-	-	201 -

Approach	EB	WB	NB
HCM Control Delay, s	0	1.3	65.7
HCM LOS			F

Minor Lane/Major Mvmt	NBLn1	NBLn2	EBT	EBR	WBL	WBT
Capacity (veh/h)	33	546	-	-	735	-
HCM Lane V/C Ratio	0.932	0.27	-	-	0.188	-
HCM Control Delay (s)	\$ 313.4	14	-	-	11	-
HCM Lane LOS	F	B	-	-	B	-
HCM 95th %tile Q(veh)	3.3	1.1	-	-	0.7	-

HCM Signalized Intersection Capacity Analysis General Plan 2040 Project Altern. B Conditions  
 6: Conde Lane & Shiloh Road

Timing Plan: Saturday Midday Peak

												
Movement	EBL	EBT	EBR	WBL	WBT	WBR	NBL	NBT	NBR	SBL	SBT	SBR
Lane Configurations												
Traffic Volume (vph)	43	551	1	13	613	301	1	0	9	291	0	41
Future Volume (vph)	43	551	1	13	613	301	1	0	9	291	0	41
Ideal Flow (vphpl)	1900	1900	1900	1900	1900	1900	1900	1900	1900	1900	1900	1900
Total Lost time (s)	4.5	4.5		4.5	4.5			4.5			4.5	4.5
Lane Util. Factor	1.00	0.95		1.00	0.95			1.00			1.00	1.00
Frbp, ped/bikes	1.00	1.00		1.00	0.99			1.00			1.00	1.00
Flpb, ped/bikes	1.00	1.00		1.00	1.00			1.00			1.00	1.00
Frt	1.00	1.00		1.00	0.95			0.88			1.00	0.85
Flt Protected	0.95	1.00		0.95	1.00			0.99			0.95	1.00
Satd. Flow (prot)	1770	3538		1770	3340			1630			1770	1583
Flt Permitted	0.95	1.00		0.95	1.00			0.99			0.95	1.00
Satd. Flow (perm)	1770	3538		1770	3340			1630			1770	1583
Peak-hour factor, PHF	0.96	0.96	0.96	0.91	0.91	0.91	0.58	0.58	0.58	0.78	0.78	0.78
Adj. Flow (vph)	45	574	1	14	674	331	2	0	16	373	0	53
RTOR Reduction (vph)	0	0	0	0	49	0	0	17	0	0	0	0
Lane Group Flow (vph)	45	575	0	14	956	0	0	1	0	0	373	53
Confl. Bikes (#/hr)						2						
Turn Type	Prot	NA		Prot	NA		Split	NA		Split	NA	custom
Protected Phases	5	2		1	6		7	7		4	4	
Permitted Phases												6
Actuated Green, G (s)	4.1	30.7		1.1	27.7			2.8			12.6	27.7
Effective Green, g (s)	4.1	30.7		1.1	27.7			2.8			12.6	27.7
Actuated g/C Ratio	0.06	0.47		0.02	0.42			0.04			0.19	0.42
Clearance Time (s)	4.5	4.5		4.5	4.5			4.5			4.5	4.5
Vehicle Extension (s)	3.0	3.0		3.0	3.0			3.0			3.0	3.0
Lane Grp Cap (vph)	111	1665		29	1418			70			342	672
v/s Ratio Prot	c0.03	c0.16		0.01	c0.29			c0.00			c0.21	
v/s Ratio Perm												0.03
v/c Ratio	0.41	0.35		0.48	0.67			0.01			1.09	0.08
Uniform Delay, d1	29.4	10.9		31.8	15.1			29.9			26.3	11.2
Progression Factor	1.00	1.00		1.00	1.00			1.00			1.00	1.00
Incremental Delay, d2	2.4	0.1		12.1	1.3			0.1			75.2	0.1
Delay (s)	31.8	11.0		43.9	16.4			29.9			101.5	11.2
Level of Service	C	B		D	B			C			F	B
Approach Delay (s)		12.5			16.8			29.9			90.2	
Approach LOS		B			B			C			F	
<b>Intersection Summary</b>												
HCM 2000 Control Delay			30.6									HCM 2000 Level of Service C
HCM 2000 Volume to Capacity ratio			0.72									
Actuated Cycle Length (s)			65.2							18.0		
Intersection Capacity Utilization			66.0%									ICU Level of Service C
Analysis Period (min)			15									
c Critical Lane Group												

HCM 6th TWSC  
7: Driveway 1/Gridley Drive & Shiloh Road

General Plan 2040 Project Altern. B Conditions  
Timing Plan: Saturday Midday Peak

Intersection												
Int Delay, s/veh	6.8											
Movement	EBL	EBT	EBR	WBL	WBT	WBR	NBL	NBT	NBR	SBL	SBT	SBR
Lane Configurations		↕	↗		↕		↕	↗			↕	
Traffic Vol, veh/h	30	473	103	0	482	0	113	0	0	0	0	27
Future Vol, veh/h	30	473	103	0	482	0	113	0	0	0	0	27
Conflicting Peds, #/hr	1	0	0	0	0	0	0	0	0	0	0	0
Sign Control	Free	Free	Free	Free	Free	Free	Stop	Stop	Stop	Stop	Stop	Stop
RT Channelized	-	-	None	-	-	None	-	-	None	-	-	None
Storage Length	-	-	150	-	-	-	0	-	-	-	-	-
Veh in Median Storage, #	-	0	-	-	0	-	-	0	-	-	0	-
Grade, %	-	0	-	-	0	-	-	0	-	-	0	-
Peak Hour Factor	93	93	93	88	88	88	100	100	100	56	56	56
Heavy Vehicles, %	2	2	2	2	2	2	2	2	2	2	2	2
Mvmt Flow	32	509	111	0	548	0	113	0	0	0	0	48

Major/Minor	Major1			Major2			Minor1			Minor2		
Conflicting Flow All	549	0	0	620	0	0	1145	1122	509	1178	1233	549
Stage 1	-	-	-	-	-	-	573	573	-	549	549	-
Stage 2	-	-	-	-	-	-	572	549	-	629	684	-
Critical Hdwy	4.12	-	-	4.12	-	-	7.12	6.52	6.22	7.12	6.52	6.22
Critical Hdwy Stg 1	-	-	-	-	-	-	6.12	5.52	-	6.12	5.52	-
Critical Hdwy Stg 2	-	-	-	-	-	-	6.12	5.52	-	6.12	5.52	-
Follow-up Hdwy	2.218	-	-	2.218	-	-	3.518	4.018	3.318	3.518	4.018	3.318
Pot Cap-1 Maneuver	1021	-	-	960	-	-	177	206	564	168	177	535
Stage 1	-	-	-	-	-	-	505	504	-	520	516	-
Stage 2	-	-	-	-	-	-	505	516	-	470	449	-
Platoon blocked, %		-	-		-	-						
Mov Cap-1 Maneuver	1020	-	-	960	-	-	155	196	564	162	168	534
Mov Cap-2 Maneuver	-	-	-	-	-	-	155	196	-	162	168	-
Stage 1	-	-	-	-	-	-	480	479	-	494	515	-
Stage 2	-	-	-	-	-	-	459	515	-	447	427	-

Approach	EB	WB	NB	SB
HCM Control Delay, s	0.4	0	73.7	12.4
HCM LOS			F	B

Minor Lane/Major Mvmt	NBLn1	NBLn2	EBL	EBT	EBR	WBL	WBT	WBR	SBLn1
Capacity (veh/h)	155	-	1020	-	-	960	-	-	534
HCM Lane V/C Ratio	0.729	-	0.032	-	-	-	-	-	0.09
HCM Control Delay (s)	73.7	0	8.6	0	-	0	-	-	12.4
HCM Lane LOS	F	A	A	A	-	A	-	-	B
HCM 95th %tile Q(veh)	4.4	-	0.1	-	-	0	-	-	0.3

HCM 6th TWSC  
8: Old Redwood Hwy & Driveway 2

General Plan 2040 Project Altern. B Conditions  
Timing Plan: Saturday Midday Peak

Intersection												
Int Delay, s/veh	5.6											
Movement	EBL	EBT	EBR	WBL	WBT	WBR	NBL	NBT	NBR	SBL	SBT	SBR
Lane Configurations		↕		↕	↕			↕	↕	↕	↕	
Traffic Vol, veh/h	1	0	3	67	0	106	1	595	61	97	505	6
Future Vol, veh/h	1	0	3	67	0	106	1	595	61	97	505	6
Conflicting Peds, #/hr	0	0	0	0	0	0	1	0	4	4	0	1
Sign Control	Stop	Stop	Stop	Stop	Stop	Stop	Free	Free	Free	Free	Free	Free
RT Channelized	-	-	None	-	-	None	-	-	None	-	-	None
Storage Length	-	-	-	0	-	-	-	-	100	50	-	-
Veh in Median Storage, #	-	0	-	-	0	-	-	0	-	-	0	-
Grade, %	-	0	-	-	0	-	-	0	-	-	0	-
Peak Hour Factor	38	38	38	100	100	100	94	94	94	93	93	93
Heavy Vehicles, %	2	2	2	2	2	2	2	2	2	2	2	2
Mvmt Flow	3	0	8	67	0	106	1	633	65	104	543	6

Major/Minor	Minor2		Minor1		Major1		Major2					
Conflicting Flow All	1476	1459	547	1397	1397	637	550	0	0	702	0	0
Stage 1	755	755	-	639	639	-	-	-	-	-	-	-
Stage 2	721	704	-	758	758	-	-	-	-	-	-	-
Critical Hdwy	7.12	6.52	6.22	7.12	6.52	6.22	4.12	-	-	4.12	-	-
Critical Hdwy Stg 1	6.12	5.52	-	6.12	5.52	-	-	-	-	-	-	-
Critical Hdwy Stg 2	6.12	5.52	-	6.12	5.52	-	-	-	-	-	-	-
Follow-up Hdwy	3.518	4.018	3.318	3.518	4.018	3.318	2.218	-	-	2.218	-	-
Pot Cap-1 Maneuver	104	129	537	118	141	477	1020	-	-	895	-	-
Stage 1	401	417	-	464	470	-	-	-	-	-	-	-
Stage 2	419	440	-	399	415	-	-	-	-	-	-	-
Platoon blocked, %								-	-	-	-	-
Mov Cap-1 Maneuver	73	113	536	105	124	475	1019	-	-	892	-	-
Mov Cap-2 Maneuver	73	113	-	105	124	-	-	-	-	-	-	-
Stage 1	400	368	-	461	467	-	-	-	-	-	-	-
Stage 2	325	437	-	347	366	-	-	-	-	-	-	-

Approach	EB	WB	NB	SB
HCM Control Delay, s	23.3	42.4	0	1.5
HCM LOS	C	E		

Minor Lane/Major Mvmt	NBL	NBT	NBR	EBLn1	WBLn1	WBLn2	SBL	SBT	SBR
Capacity (veh/h)	1019	-	-	207	105	475	892	-	-
HCM Lane V/C Ratio	0.001	-	-	0.051	0.638	0.223	0.117	-	-
HCM Control Delay (s)	8.5	0	-	23.3	86.2	14.7	9.6	-	-
HCM Lane LOS	A	A	-	C	F	B	A	-	-
HCM 95th %tile Q(veh)	0	-	-	0.2	3.2	0.8	0.4	-	-

Intersection						
Int Delay, s/veh	6.8					
Movement	EBT	EBR	WBL	WBT	NBL	NBR
Lane Configurations	↑	↗		↖	↖	↗
Traffic Vol, veh/h	136	316	30	127	346	33
Future Vol, veh/h	136	316	30	127	346	33
Conflicting Peds, #/hr	0	1	0	0	0	0
Sign Control	Free	Free	Free	Free	Stop	Stop
RT Channelized	-	None	-	None	-	None
Storage Length	-	200	-	-	0	0
Veh in Median Storage, #	0	-	-	0	0	-
Grade, %	0	-	-	0	0	-
Peak Hour Factor	88	88	80	80	100	100
Heavy Vehicles, %	2	2	2	2	2	2
Mvmt Flow	155	359	38	159	346	33

Major/Minor	Major1	Major2	Minor1		
Conflicting Flow All	0	0	515	0	391
Stage 1	-	-	-	-	156
Stage 2	-	-	-	-	235
Critical Hdwy	-	-	4.12	-	6.42
Critical Hdwy Stg 1	-	-	-	-	5.42
Critical Hdwy Stg 2	-	-	-	-	5.42
Follow-up Hdwy	-	-	2.218	-	3.518
Pot Cap-1 Maneuver	-	-	1051	-	613
Stage 1	-	-	-	-	872
Stage 2	-	-	-	-	804
Platoon blocked, %	-	-	-	-	-
Mov Cap-1 Maneuver	-	-	1050	-	588
Mov Cap-2 Maneuver	-	-	-	-	588
Stage 1	-	-	-	-	871
Stage 2	-	-	-	-	772

Approach	EB	WB	NB
HCM Control Delay, s	0	1.6	18.6
HCM LOS			C

Minor Lane/Major Mvmt	NBLn1	NBLn2	EBT	EBR	WBL	WBT
Capacity (veh/h)	588	889	-	-	1050	-
HCM Lane V/C Ratio	0.588	0.037	-	-	0.036	-
HCM Control Delay (s)	19.5	9.2	-	-	8.6	0
HCM Lane LOS	C	A	-	-	A	A
HCM 95th %tile Q(veh)	3.8	0.1	-	-	0.1	-

HCM 6th Signalized Intersection Summary      General Plan 2040 Project Altern. B Conditions  
 10: US 101 NB Off Ramp/Lakewood Drive & Old Redwood Highway      Timing Plan: Saturday Midday Peak

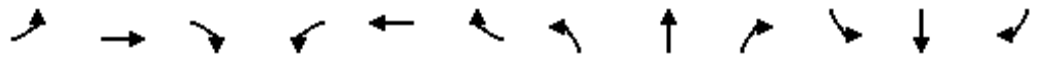

Movement	EBL	EBT	EBR	WBL	WBT	WBR	NBL	NBT	NBR	SBL	SBT	SBR
Lane Configurations	↔↔	↑			↑↑		↔	↔↔		↔↔		↔
Traffic Volume (veh/h)	372	467	0	0	718	357	415	393	185	316	0	908
Future Volume (veh/h)	372	467	0	0	718	357	415	393	185	316	0	908
Initial Q (Qb), veh	0	0	0	0	0	0	0	0	0	0	0	0
Ped-Bike Adj(A_pbT)	1.00		1.00	1.00		0.98	1.00		1.00	1.00		1.00
Parking Bus, Adj	1.00	1.00	1.00	1.00	1.00	1.00	1.00	1.00	1.00	1.00	1.00	1.00
Work Zone On Approach		No			No			No			No	
Adj Sat Flow, veh/h/ln	1870	1870	0	0	1870	1870	1870	1870	1870	1870	0	1870
Adj Flow Rate, veh/h	392	492	0	0	807	401	338	520	189	359	0	0
Peak Hour Factor	0.95	0.95	0.95	0.89	0.89	0.89	0.98	0.98	0.98	0.88	0.88	0.88
Percent Heavy Veh, %	2	2	0	0	2	2	2	2	2	2	0	2
Cap, veh/h	374	1101	0	0	952	471	501	737	267	0	0	
Arrive On Green	0.11	0.59	0.00	0.00	0.42	0.42	0.28	0.28	0.28	0.00	0.00	0.00
Sat Flow, veh/h	3456	1870	0	0	2384	1132	1781	2621	948		0	
Grp Volume(v), veh/h	392	492	0	0	625	583	338	370	339		0.0	
Grp Sat Flow(s),veh/h/ln	1728	1870	0	0	1777	1646	1781	1870	1699			
Q Serve(g_s), s	7.5	10.2	0.0	0.0	22.0	22.2	11.7	12.3	12.4			
Cycle Q Clear(g_c), s	7.5	10.2	0.0	0.0	22.0	22.2	11.7	12.3	12.4			
Prop In Lane	1.00		0.00	0.00		0.69	1.00		0.56			
Lane Grp Cap(c), veh/h	374	1101	0	0	738	684	501	526	478			
V/C Ratio(X)	1.05	0.45	0.00	0.00	0.85	0.85	0.67	0.70	0.71			
Avail Cap(c_a), veh/h	374	1101	0	0	738	684	751	788	716			
HCM Platoon Ratio	1.00	1.00	1.00	1.00	1.00	1.00	1.00	1.00	1.00			
Upstream Filter(I)	1.00	1.00	0.00	0.00	1.00	1.00	1.00	1.00	1.00			
Uniform Delay (d), s/veh	30.9	8.0	0.0	0.0	18.3	18.3	22.1	22.3	22.3			
Incr Delay (d2), s/veh	59.7	1.3	0.0	0.0	11.5	12.7	1.6	1.7	1.9			
Initial Q Delay(d3),s/veh	0.0	0.0	0.0	0.0	0.0	0.0	0.0	0.0	0.0			
%ile BackOfQ(50%),veh/ln	6.0	3.6	0.0	0.0	10.2	9.8	4.8	5.3	4.9			
Unsig. Movement Delay, s/veh												
LnGrp Delay(d),s/veh	90.6	9.3	0.0	0.0	29.8	31.1	23.7	24.0	24.3			
LnGrp LOS	F	A	A	A	C	C	C	C	C			
Approach Vol, veh/h		884			1208			1047				
Approach Delay, s/veh		45.3			30.4			24.0				
Approach LOS		D			C			C				
Timer - Assigned Phs		2			5	6		8				
Phs Duration (G+Y+Rc), s		45.3			12.0	33.3		24.0				
Change Period (Y+Rc), s		4.5			4.5	4.5		4.5				
Max Green Setting (Gmax), s		40.8			7.5	28.8		29.2				
Max Q Clear Time (g_c+I1), s		12.2			9.5	24.2		14.4				
Green Ext Time (p_c), s		3.2			0.0	3.0		5.0				

**Intersection Summary**

HCM 6th Ctrl Delay	32.5
HCM 6th LOS	C

**Notes**

User approved volume balancing among the lanes for turning movement.  
 Unsignalized Delay for [SBR] is excluded from calculations of the approach delay and intersection delay.

HCM 6th Signalized Intersection Summary      General Plan 2040 Project Altern. B Conditions  
 12: US 101 SB On Ramp/US 101 SB Off Ramp & Old Redwood Highway      Timing Plan: Saturday Midday Peak

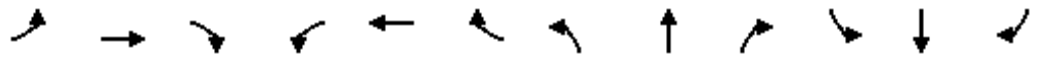

Movement	EBL	EBT	EBR	WBL	WBT	WBR	NBL	NBT	NBR	SBL	SBT	SBR
Lane Configurations		↑↑	↗	↖	↑↑					↘	↕	
Traffic Volume (veh/h)	0	713	543	632	1060	0	0	0	0	257	1	112
Future Volume (veh/h)	0	713	543	632	1060	0	0	0	0	257	1	112
Initial Q (Qb), veh	0	0	0	0	0	0				0	0	0
Ped-Bike Adj(A_pbT)	1.00		0.98	1.00		1.00				1.00		1.00
Parking Bus, Adj	1.00	1.00	1.00	1.00	1.00	1.00				1.00	1.00	1.00
Work Zone On Approach		No			No						No	
Adj Sat Flow, veh/h/ln	0	1870	1870	1870	1870	0				1870	1870	1870
Adj Flow Rate, veh/h	0	735	560	658	1104	0				257	141	0
Peak Hour Factor	0.97	0.97	0.97	0.96	0.96	0.96				0.72	0.72	0.72
Percent Heavy Veh, %	0	2	2	2	2	0				2	2	2
Cap, veh/h	0	1411	617	471	2579	0				260	273	
Arrive On Green	0.00	0.40	0.40	0.26	0.73	0.00				0.15	0.15	0.00
Sat Flow, veh/h	0	3647	1555	1781	3647	0				1781	1870	0
Grp Volume(v), veh/h	0	735	560	658	1104	0				257	141	0
Grp Sat Flow(s),veh/h/ln	0	1777	1555	1781	1777	0				1781	1870	0
Q Serve(g_s), s	0.0	11.0	23.8	18.5	8.7	0.0				10.1	4.9	0.0
Cycle Q Clear(g_c), s	0.0	11.0	23.8	18.5	8.7	0.0				10.1	4.9	0.0
Prop In Lane	0.00		1.00	1.00		0.00				1.00		0.00
Lane Grp Cap(c), veh/h	0	1411	617	471	2579	0				260	273	
V/C Ratio(X)	0.00	0.52	0.91	1.40	0.43	0.00				0.99	0.52	
Avail Cap(c_a), veh/h	0	1411	617	471	2579	0				260	273	
HCM Platoon Ratio	1.00	1.00	1.00	1.00	1.00	1.00				1.00	1.00	1.00
Upstream Filter(I)	0.00	1.00	1.00	1.00	1.00	0.00				1.00	1.00	0.00
Uniform Delay (d), s/veh	0.0	16.0	19.9	25.8	3.8	0.0				29.8	27.6	0.0
Incr Delay (d2), s/veh	0.0	1.4	19.4	191.5	0.5	0.0				53.0	1.7	0.0
Initial Q Delay(d3),s/veh	0.0	0.0	0.0	0.0	0.0	0.0				0.0	0.0	0.0
%ile BackOfQ(50%),veh/ln	0.0	4.3	10.9	32.2	2.0	0.0				7.9	2.2	0.0
Unsig. Movement Delay, s/veh												
LnGrp Delay(d),s/veh	0.0	17.4	39.3	217.3	4.3	0.0				82.8	29.3	0.0
LnGrp LOS	A	B	D	F	A	A				F	C	
Approach Vol, veh/h		1295			1762						398	
Approach Delay, s/veh		26.9			83.9						63.9	
Approach LOS		C			F						E	
Timer - Assigned Phs		2			5	6		8				
Phs Duration (G+Y+Rc), s		55.3			23.0	32.3		14.7				
Change Period (Y+Rc), s		4.5			4.5	4.5		4.5				
Max Green Setting (Gmax), s		50.8			18.5	27.8		10.2				
Max Q Clear Time (g_c+I1), s		10.7			20.5	25.8		12.1				
Green Ext Time (p_c), s		10.0			0.0	1.4		0.0				

**Intersection Summary**

HCM 6th Ctrl Delay	60.2
HCM 6th LOS	E

**Notes**

- User approved volume balancing among the lanes for turning movement.
- User approved ignoring U-Turning movement.
- Unsignalized Delay for [SBR] is excluded from calculations of the approach delay and intersection delay.

Queues  
1: Old Redwood Hwy & Shiloh Road

General Plan 2040 Project Altern. B Conditions

Timing Plan: A.M. PEAK



Lane Group	EBL	EBT	EBR	WBT	WBR	NBL	NBT	NBR	SBL	SBT	SBR
Lane Group Flow (vph)	386	383	543	317	33	391	335	19	62	564	468
v/c Ratio	0.88	0.83	0.86	0.81	0.08	1.88	0.51	0.03	0.72	1.06	0.87
Control Delay	67.9	61.5	32.6	62.6	0.4	443.1	35.9	0.1	100.8	99.9	46.9
Queue Delay	0.0	0.0	0.0	0.0	0.0	0.0	0.0	0.0	0.0	0.0	0.0
Total Delay	67.9	61.5	32.6	62.6	0.4	443.1	35.9	0.1	100.8	99.9	46.9
Queue Length 50th (ft)	296	290	182	242	0	~474	209	0	50	~494	258
Queue Length 95th (ft)	#441	#417	280	340	0	#730	337	0	#126	#729	#442
Internal Link Dist (ft)		1709		528			668			695	
Turn Bay Length (ft)	375		140		50	200		98	130		93
Base Capacity (vph)	439	462	635	571	562	208	659	610	86	530	541
Starvation Cap Reductn	0	0	0	0	0	0	0	0	0	0	0
Spillback Cap Reductn	0	0	0	0	0	0	0	0	0	0	0
Storage Cap Reductn	0	0	0	0	0	0	0	0	0	0	0
Reduced v/c Ratio	0.88	0.83	0.86	0.56	0.06	1.88	0.51	0.03	0.72	1.06	0.87

Intersection Summary

~ Volume exceeds capacity, queue is theoretically infinite.

Queue shown is maximum after two cycles.

# 95th percentile volume exceeds capacity, queue may be longer.

Queue shown is maximum after two cycles.



Queues

2: Shiloh Road & Hembree Ln

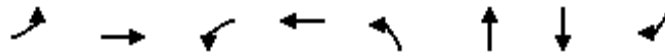

Lane Group	EBL	EBT	WBL	WBT	NBL	NBT	SBT	SBR
Lane Group Flow (vph)	353	1146	49	985	49	27	155	606
v/c Ratio	0.51	0.98	0.42	0.63	0.42	0.21	0.73	1.00
Control Delay	34.1	40.8	51.9	20.0	51.9	28.9	58.9	59.3
Queue Delay	0.0	11.5	0.0	0.0	0.0	0.0	0.0	0.0
Total Delay	34.1	52.3	51.9	20.0	51.9	28.9	58.9	59.3
Queue Length 50th (ft)	94	~719	27	209	27	6	87	~279
Queue Length 95th (ft)	134	#929	#65	273	#65	32	#189	#559
Internal Link Dist (ft)		222		1709		136	301	
Turn Bay Length (ft)			100					
Base Capacity (vph)	698	1170	116	1741	116	126	213	608
Starvation Cap Reductn	0	53	0	0	0	0	0	0
Spillback Cap Reductn	0	0	0	0	0	0	0	0
Storage Cap Reductn	0	0	0	0	0	0	0	0
Reduced v/c Ratio	0.51	1.03	0.42	0.57	0.42	0.21	0.73	1.00

Intersection Summary

~ Volume exceeds capacity, queue is theoretically infinite.

Queue shown is maximum after two cycles.

# 95th percentile volume exceeds capacity, queue may be longer.

Queue shown is maximum after two cycles.

Queues  
3: US 101 NB Off-Ramp & Shiloh Road

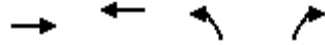

Lane Group	EBT	WBT	NBL	NBR
Lane Group Flow (vph)	803	1226	1070	792
v/c Ratio	0.50	1.44	1.40	0.61
Control Delay	15.0	225.6	212.4	14.0
Queue Delay	0.0	0.0	0.0	0.0
Total Delay	15.0	225.6	212.4	14.0
Queue Length 50th (ft)	125	~755	~651	109
Queue Length 95th (ft)	172	#986	#681	125
Internal Link Dist (ft)	106	291	689	
Turn Bay Length (ft)				265
Base Capacity (vph)	1622	853	762	1307
Starvation Cap Reductn	0	0	0	0
Spillback Cap Reductn	0	0	0	0
Storage Cap Reductn	0	0	0	0
Reduced v/c Ratio	0.50	1.44	1.40	0.61

Intersection Summary

- ~ Volume exceeds capacity, queue is theoretically infinite.  
Queue shown is maximum after two cycles.
- # 95th percentile volume exceeds capacity, queue may be longer.  
Queue shown is maximum after two cycles.

Queues  
4: Shiloh Road & US 101 SB Off-Ramp

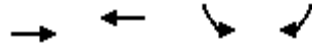

Lane Group	EBT	WBT	SBL	SBR
Lane Group Flow (vph)	454	1267	336	200
v/c Ratio	0.34	0.96	0.96	0.50
Control Delay	5.5	29.7	76.9	20.8
Queue Delay	0.0	0.0	0.0	0.0
Total Delay	5.5	29.7	76.9	20.8
Queue Length 50th (ft)	79	523	~194	46
Queue Length 95th (ft)	119	#956	#367	113
Internal Link Dist (ft)	145	226	406	
Turn Bay Length (ft)				275
Base Capacity (vph)	1409	1409	350	398
Starvation Cap Reductn	0	0	0	0
Spillback Cap Reductn	0	0	0	0
Storage Cap Reductn	0	0	0	0
Reduced v/c Ratio	0.32	0.90	0.96	0.50

Intersection Summary

- ~ Volume exceeds capacity, queue is theoretically infinite.  
Queue shown is maximum after two cycles.
- # 95th percentile volume exceeds capacity, queue may be longer.  
Queue shown is maximum after two cycles.

Queues  
6: Conde Lane & Shiloh Road

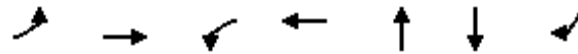

Lane Group	EBL	EBT	WBL	WBT	NBT	SBT	SBR
Lane Group Flow (vph)	58	566	9	1356	22	422	31
v/c Ratio	0.28	0.25	0.05	0.69	0.09	1.55	0.03
Control Delay	37.6	7.7	35.8	15.7	20.8	290.6	11.2
Queue Delay	0.0	0.0	0.0	0.0	0.0	0.0	0.0
Total Delay	37.6	7.7	35.8	15.7	20.8	290.6	11.2
Queue Length 50th (ft)	24	32	4	196	2	~271	6
Queue Length 95th (ft)	67	132	18	370	13	#505	22
Internal Link Dist (ft)		735		1001	338	442	
Turn Bay Length (ft)	90		127				40
Base Capacity (vph)	223	2291	198	1979	779	273	911
Starvation Cap Reductn	0	0	0	0	0	0	0
Spillback Cap Reductn	0	0	0	0	0	0	0
Storage Cap Reductn	0	0	0	0	0	0	0
Reduced v/c Ratio	0.26	0.25	0.05	0.69	0.03	1.55	0.03

Intersection Summary

~ Volume exceeds capacity, queue is theoretically infinite.  
Queue shown is maximum after two cycles.

# 95th percentile volume exceeds capacity, queue may be longer.  
Queue shown is maximum after two cycles.

Queues

10: US 101 NB Off Ramp/Lakewood Drive & Old Redwood Highway



Lane Group	EBL	EBT	WBT	NBL	NBT	SBL	SBR
Lane Group Flow (vph)	311	751	994	212	422	287	763
v/c Ratio	0.79	0.78	0.82	0.61	0.57	0.93	0.99
Control Delay	50.6	24.2	30.3	35.0	27.0	75.7	47.3
Queue Delay	0.0	0.0	0.0	0.0	0.0	0.0	0.0
Total Delay	50.6	24.2	30.3	35.0	27.0	75.7	47.3
Queue Length 50th (ft)	77	279	221	102	89	73	266
Queue Length 95th (ft)	#145	#522	#310	173	134	#163	#511
Internal Link Dist (ft)		146	537		636		
Turn Bay Length (ft)	155			270		120	
Base Capacity (vph)	396	961	1218	599	1236	308	771
Starvation Cap Reductn	0	0	0	0	0	0	0
Spillback Cap Reductn	0	0	0	0	0	0	0
Storage Cap Reductn	0	0	0	0	0	0	0
Reduced v/c Ratio	0.79	0.78	0.82	0.35	0.34	0.93	0.99

Intersection Summary

# 95th percentile volume exceeds capacity, queue may be longer.  
 Queue shown is maximum after two cycles.

Queues

12: US 101 SB On Ramp/US 101 SB Off Ramp & Old Redwood Highway



Lane Group	EBT	EBR	WBL	WBT	SBL	SBT
Lane Group Flow (vph)	760	885	628	834	205	201
v/c Ratio	0.63	1.15	0.98	0.31	0.98	0.58
Control Delay	25.1	101.9	58.5	3.6	94.8	15.0
Queue Delay	0.0	0.0	0.0	0.0	0.0	0.0
Total Delay	25.1	101.9	58.5	3.6	94.8	15.0
Queue Length 50th (ft)	165	~400	304	55	109	10
Queue Length 95th (ft)	224	#624	#511	73	#210	55
Internal Link Dist (ft)	343			451		751
Turn Bay Length (ft)			250		420	
Base Capacity (vph)	1203	767	641	2663	210	346
Starvation Cap Reductn	0	0	0	0	0	0
Spillback Cap Reductn	0	0	0	0	0	0
Storage Cap Reductn	0	0	0	0	0	0
Reduced v/c Ratio	0.63	1.15	0.98	0.31	0.98	0.58

Intersection Summary

~ Volume exceeds capacity, queue is theoretically infinite.

Queue shown is maximum after two cycles.

# 95th percentile volume exceeds capacity, queue may be longer.

Queue shown is maximum after two cycles.

Queues  
1: Old Redwood Hwy & Shiloh Road

General Plan 2040 Project Altern. B Conditions

Timing Plan: P.M. Peak



Lane Group	EBL	EBT	EBR	WBT	WBR	NBL	NBT	NBR	SBL	SBT	SBR
Lane Group Flow (vph)	327	410	655	480	70	705	608	47	85	586	285
v/c Ratio	0.81	0.96	1.02	0.95	0.14	3.67	1.00	0.08	1.08	1.20	0.59
Control Delay	65.8	87.1	64.0	76.6	2.6	1231.4	82.2	2.3	182.8	151.0	32.6
Queue Delay	0.0	0.0	0.0	0.0	0.0	0.0	0.0	0.0	0.0	0.0	0.0
Total Delay	65.8	87.1	64.0	76.6	2.6	1231.4	82.2	2.3	182.8	151.0	32.6
Queue Length 50th (ft)	274	360	~348	410	0	~1110	~546	0	~83	~627	139
Queue Length 95th (ft)	#424	#571	#588	#616	14	#1352	#792	11	#196	#858	238
Internal Link Dist (ft)		1709		528			668			695	
Turn Bay Length (ft)	375		140		50	200		98	130		93
Base Capacity (vph)	403	425	641	527	515	192	607	555	79	488	481
Starvation Cap Reductn	0	0	0	0	0	0	0	0	0	0	0
Spillback Cap Reductn	0	0	0	0	0	0	0	0	0	0	0
Storage Cap Reductn	0	0	0	0	0	0	0	0	0	0	0
Reduced v/c Ratio	0.81	0.96	1.02	0.91	0.14	3.67	1.00	0.08	1.08	1.20	0.59

Intersection Summary

~ Volume exceeds capacity, queue is theoretically infinite.

Queue shown is maximum after two cycles.

# 95th percentile volume exceeds capacity, queue may be longer.

Queue shown is maximum after two cycles.

Queues

General Plan 2040 Project Altern. B Conditions

2: Shiloh Road & Hembree Ln

Timing Plan: P.M. Peak

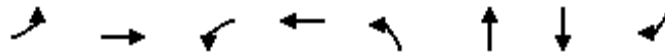

Lane Group	EBL	EBT	WBL	WBT	NBL	NBT	SBT	SBR
Lane Group Flow (vph)	703	1289	110	1384	111	149	194	554
v/c Ratio	1.08	1.18	1.02	0.86	1.03	0.68	0.98	1.07
Control Delay	96.8	112.9	136.9	28.1	139.2	27.8	103.0	85.5
Queue Delay	0.0	0.2	0.0	0.0	0.0	0.0	0.0	0.0
Total Delay	96.8	113.1	136.9	28.1	139.2	27.8	103.0	85.5
Queue Length 50th (ft)	~233	~893	~65	352	~66	12	112	~261
Queue Length 95th (ft)	#342	#1147	#171	424	#173	#91	#246	#535
Internal Link Dist (ft)		222		1709		136	301	
Turn Bay Length (ft)			100					
Base Capacity (vph)	648	1090	108	1614	108	219	197	517
Starvation Cap Reductn	0	42	0	0	0	0	0	0
Spillback Cap Reductn	0	0	0	0	0	0	0	0
Storage Cap Reductn	0	0	0	0	0	0	0	0
Reduced v/c Ratio	1.08	1.23	1.02	0.86	1.03	0.68	0.98	1.07

Intersection Summary

~ Volume exceeds capacity, queue is theoretically infinite.

Queue shown is maximum after two cycles.

# 95th percentile volume exceeds capacity, queue may be longer.

Queue shown is maximum after two cycles.



Queues  
3: US 101 NB Off-Ramp & Shiloh Road



Lane Group	EBT	WBT	NBL	NBR
Lane Group Flow (vph)	952	1112	771	1043
v/c Ratio	0.59	1.30	1.01	0.82
Control Delay	16.3	167.5	58.8	22.8
Queue Delay	0.0	0.0	0.0	0.0
Total Delay	16.3	167.5	58.8	22.8
Queue Length 50th (ft)	157	~647	~339	199
Queue Length 95th (ft)	213	#872	#571	#294
Internal Link Dist (ft)	106	291	689	
Turn Bay Length (ft)				265
Base Capacity (vph)	1622	853	762	1268
Starvation Cap Reductn	0	0	0	0
Spillback Cap Reductn	0	0	0	0
Storage Cap Reductn	0	0	0	0
Reduced v/c Ratio	0.59	1.30	1.01	0.82

Intersection Summary

- ~ Volume exceeds capacity, queue is theoretically infinite.  
Queue shown is maximum after two cycles.
- # 95th percentile volume exceeds capacity, queue may be longer.  
Queue shown is maximum after two cycles.

Queues  
4: Shiloh Road & US 101 SB Off-Ramp

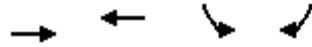

Lane Group	EBT	WBT	SBL	SBR
Lane Group Flow (vph)	740	1125	467	101
v/c Ratio	0.60	0.91	1.15	0.23
Control Delay	9.0	22.7	125.7	8.6
Queue Delay	0.0	0.0	0.0	0.0
Total Delay	9.0	22.7	125.7	8.6
Queue Length 50th (ft)	162	376	~282	0
Queue Length 95th (ft)	235	610	#545	41
Internal Link Dist (ft)	145	226	406	
Turn Bay Length (ft)				275
Base Capacity (vph)	1579	1579	405	432
Starvation Cap Reductn	0	0	0	0
Spillback Cap Reductn	0	0	0	0
Storage Cap Reductn	0	0	0	0
Reduced v/c Ratio	0.47	0.71	1.15	0.23

Intersection Summary

- ~ Volume exceeds capacity, queue is theoretically infinite.  
Queue shown is maximum after two cycles.
- # 95th percentile volume exceeds capacity, queue may be longer.  
Queue shown is maximum after two cycles.

Queues  
6: Conde Lane & Shiloh Road

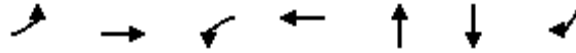

Lane Group	EBL	EBT	WBL	WBT	NBT	SBT	SBR
Lane Group Flow (vph)	88	823	11	1394	34	445	74
v/c Ratio	0.45	0.37	0.06	0.77	0.14	1.75	0.09
Control Delay	44.0	9.4	37.1	19.6	19.5	381.4	12.6
Queue Delay	0.0	0.0	0.0	0.0	0.0	0.0	0.0
Total Delay	44.0	9.4	37.1	19.6	19.5	381.4	12.6
Queue Length 50th (ft)	46	105	6	324	4	~384	22
Queue Length 95th (ft)	91	196	19	340	18	#549	44
Internal Link Dist (ft)		735		1001	338	442	
Turn Bay Length (ft)	90		127				40
Base Capacity (vph)	207	2236	184	1822	728	254	844
Starvation Cap Reductn	0	0	0	0	0	0	0
Spillback Cap Reductn	0	0	0	0	0	0	0
Storage Cap Reductn	0	0	0	0	0	0	0
Reduced v/c Ratio	0.43	0.37	0.06	0.77	0.05	1.75	0.09

Intersection Summary

~ Volume exceeds capacity, queue is theoretically infinite.  
Queue shown is maximum after two cycles.

# 95th percentile volume exceeds capacity, queue may be longer.  
Queue shown is maximum after two cycles.

Queues

10: US 101 NB Off Ramp/Lakewood Drive & Old Redwood Highway



Lane Group	EBL	EBT	WBT	NBL	NBT	SBL	SBR
Lane Group Flow (vph)	355	824	1128	499	990	402	644
v/c Ratio	1.03	0.99	1.06	0.96	0.92	1.51	0.73
Control Delay	99.4	55.4	76.4	63.3	41.4	277.9	17.2
Queue Delay	0.0	0.0	0.0	0.0	0.0	0.0	0.0
Total Delay	99.4	55.4	76.4	63.3	41.4	277.9	17.2
Queue Length 50th (ft)	~112	450	~363	303	274	~165	176
Queue Length 95th (ft)	#189	#670	#492	#523	#406	#256	319
Internal Link Dist (ft)		146	537		636		
Turn Bay Length (ft)	155			270		120	
Base Capacity (vph)	343	832	1061	518	1080	267	879
Starvation Cap Reductn	0	0	0	0	0	0	0
Spillback Cap Reductn	0	0	0	0	0	0	0
Storage Cap Reductn	0	0	0	0	0	0	0
Reduced v/c Ratio	1.03	0.99	1.06	0.96	0.92	1.51	0.73

Intersection Summary

~ Volume exceeds capacity, queue is theoretically infinite.

Queue shown is maximum after two cycles.

# 95th percentile volume exceeds capacity, queue may be longer.

Queue shown is maximum after two cycles.

Queues

12: US 101 SB On Ramp/US 101 SB Off Ramp & Old Redwood Highway



Lane Group	EBT	EBR	WBL	WBT	SBL	SBT
Lane Group Flow (vph)	651	533	498	1260	359	326
v/c Ratio	0.46	0.60	1.09	0.50	1.45	1.05
Control Delay	16.8	6.4	98.8	5.3	252.8	89.9
Queue Delay	0.0	0.0	0.0	0.0	0.0	0.0
Total Delay	16.8	6.4	98.8	5.3	252.8	89.9
Queue Length 50th (ft)	105	24	~248	101	~227	~123
Queue Length 95th (ft)	149	98	#412	133	#348	#243
Internal Link Dist (ft)	343			451		751
Turn Bay Length (ft)			250		420	
Base Capacity (vph)	1410	887	455	2522	247	310
Starvation Cap Reductn	0	0	0	0	0	0
Spillback Cap Reductn	0	0	0	0	0	0
Storage Cap Reductn	0	0	0	0	0	0
Reduced v/c Ratio	0.46	0.60	1.09	0.50	1.45	1.05

Intersection Summary

~ Volume exceeds capacity, queue is theoretically infinite.

Queue shown is maximum after two cycles.

# 95th percentile volume exceeds capacity, queue may be longer.

Queue shown is maximum after two cycles.

Queues  
1: Old Redwood Hwy & Shiloh Road

General Plan 2040 Project Altern. B Conditions  
Timing Plan: Saturday Midday Peak



Lane Group	EBL	EBT	EBR	WBT	WBR	NBL	NBT	NBR	SBL	SBT	SBR
Lane Group Flow (vph)	204	534	338	629	88	338	377	38	87	312	292
v/c Ratio	0.48	1.19	0.70	1.13	0.16	1.72	0.73	0.08	1.13	0.81	0.65
Control Delay	46.8	147.1	34.2	118.9	3.7	380.8	50.7	0.3	197.8	63.8	27.3
Queue Delay	0.0	0.0	0.0	0.0	0.0	0.0	0.0	0.0	0.0	0.0	0.0
Total Delay	46.8	147.1	34.2	118.9	3.7	380.8	50.7	0.3	197.8	63.8	27.3
Queue Length 50th (ft)	145	~531	149	~601	0	~411	281	0	~83	245	99
Queue Length 95th (ft)	236	#800	274	#842	20	#643	393	0	#206	350	197
Internal Link Dist (ft)		1709		528			668			695	
Turn Bay Length (ft)	375		140		50	200		98	130		93
Base Capacity (vph)	427	449	483	558	555	196	641	587	77	516	541
Starvation Cap Reductn	0	0	0	0	0	0	0	0	0	0	0
Spillback Cap Reductn	0	0	0	0	0	0	0	0	0	0	0
Storage Cap Reductn	0	0	0	0	0	0	0	0	0	0	0
Reduced v/c Ratio	0.48	1.19	0.70	1.13	0.16	1.72	0.59	0.06	1.13	0.60	0.54

Intersection Summary

~ Volume exceeds capacity, queue is theoretically infinite.

Queue shown is maximum after two cycles.

# 95th percentile volume exceeds capacity, queue may be longer.

Queue shown is maximum after two cycles.

Queues

General Plan 2040 Project Altern. B Conditions

2: Shiloh Road & Hembree Ln

Timing Plan: Saturday Midday Peak

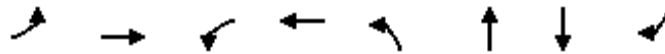

Lane Group	EBL	EBT	WBL	WBT	NBL	NBT	SBT	SBR
Lane Group Flow (vph)	977	949	110	1074	110	149	270	941
v/c Ratio	1.40	0.92	0.95	0.74	0.95	0.66	1.27	1.63
Control Delay	217.0	32.3	114.9	22.4	114.9	26.4	187.9	310.1
Queue Delay	0.0	1.0	0.0	0.0	0.0	0.0	0.0	0.0
Total Delay	217.0	33.3	114.9	22.4	114.9	26.4	187.9	310.1
Queue Length 50th (ft)	~401	417	~65	228	~65	12	~204	~774
Queue Length 95th (ft)	#522	#715	#171	300	#171	#91	#357	#1012
Internal Link Dist (ft)		222		1709		136	301	
Turn Bay Length (ft)			100					
Base Capacity (vph)	699	1173	116	1724	116	226	213	579
Starvation Cap Reductn	0	72	0	0	0	0	0	0
Spillback Cap Reductn	0	0	0	0	0	0	0	0
Storage Cap Reductn	0	0	0	0	0	0	0	0
Reduced v/c Ratio	1.40	0.86	0.95	0.62	0.95	0.66	1.27	1.63

Intersection Summary

~ Volume exceeds capacity, queue is theoretically infinite.

Queue shown is maximum after two cycles.

# 95th percentile volume exceeds capacity, queue may be longer.

Queue shown is maximum after two cycles.

Queues  
3: US 101 NB Off-Ramp & Shiloh Road

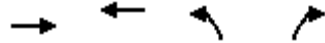

Lane Group	EBT	WBT	NBL	NBR
Lane Group Flow (vph)	775	1385	547	1093
v/c Ratio	0.47	1.60	0.76	0.88
Control Delay	14.4	295.1	26.1	25.2
Queue Delay	0.0	0.0	0.0	0.0
Total Delay	14.4	295.1	26.1	25.2
Queue Length 50th (ft)	121	~912	195	198
Queue Length 95th (ft)	168	#1132	312	#314
Internal Link Dist (ft)	106	291	689	
Turn Bay Length (ft)				265
Base Capacity (vph)	1649	868	773	1330
Starvation Cap Reductn	0	0	0	0
Spillback Cap Reductn	0	0	0	0
Storage Cap Reductn	0	0	0	0
Reduced v/c Ratio	0.47	1.60	0.71	0.82

Intersection Summary

- ~ Volume exceeds capacity, queue is theoretically infinite.  
Queue shown is maximum after two cycles.
- # 95th percentile volume exceeds capacity, queue may be longer.  
Queue shown is maximum after two cycles.



Queues  
4: Shiloh Road & US 101 SB Off-Ramp

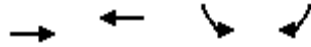

Lane Group	EBT	WBT	SBL	SBR
Lane Group Flow (vph)	439	826	588	328
v/c Ratio	0.44	0.82	1.12	0.51
Control Delay	8.8	18.0	101.6	9.7
Queue Delay	0.0	0.0	0.0	0.0
Total Delay	8.8	18.0	101.6	9.7
Queue Length 50th (ft)	78	202	~231	20
Queue Length 95th (ft)	125	323	#366	46
Internal Link Dist (ft)	145	226	406	
Turn Bay Length (ft)				275
Base Capacity (vph)	1825	1825	526	641
Starvation Cap Reductn	0	0	0	0
Spillback Cap Reductn	0	0	0	0
Storage Cap Reductn	0	0	0	0
Reduced v/c Ratio	0.24	0.45	1.12	0.51

Intersection Summary

- ~ Volume exceeds capacity, queue is theoretically infinite.  
Queue shown is maximum after two cycles.
- # 95th percentile volume exceeds capacity, queue may be longer.  
Queue shown is maximum after two cycles.

Queues  
6: Conde Lane & Shiloh Road

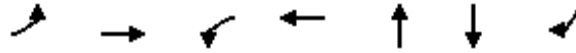

Lane Group	EBL	EBT	WBL	WBT	NBT	SBT	SBR
Lane Group Flow (vph)	45	575	14	1005	18	373	53
v/c Ratio	0.16	0.31	0.05	0.67	0.05	0.99	0.08
Control Delay	33.0	9.7	33.5	15.9	0.2	79.8	13.0
Queue Delay	0.0	0.0	0.0	0.0	0.0	0.0	0.0
Total Delay	33.0	9.7	33.5	15.9	0.2	79.8	13.0
Queue Length 50th (ft)	13	35	4	124	0	~143	10
Queue Length 95th (ft)	56	141	26	263	0	#392	31
Internal Link Dist (ft)		735		1001	338	442	
Turn Bay Length (ft)	90		127				40
Base Capacity (vph)	290	2693	273	2516	1074	375	1182
Starvation Cap Reductn	0	0	0	0	0	0	0
Spillback Cap Reductn	0	0	0	0	0	0	0
Storage Cap Reductn	0	0	0	0	0	0	0
Reduced v/c Ratio	0.16	0.21	0.05	0.40	0.02	0.99	0.04

Intersection Summary

~ Volume exceeds capacity, queue is theoretically infinite.

Queue shown is maximum after two cycles.

# 95th percentile volume exceeds capacity, queue may be longer.

Queue shown is maximum after two cycles.

Queues

General Plan 2040 Project Altern. B Conditions

10: US 101 NB Off Ramp/Lakewood Drive & Old Redwood Highway Timing Plan: Saturday Midday Peak



Lane Group	EBL	EBT	WBT	NBL	NBT	SBL	SBR
Lane Group Flow (vph)	392	492	1208	338	675	359	1032
v/c Ratio	1.31	0.56	1.02	0.73	0.70	1.29	1.27
Control Delay	195.7	20.1	58.8	37.9	28.9	188.2	152.3
Queue Delay	0.0	0.0	0.0	0.0	0.0	0.0	0.0
Total Delay	195.7	20.1	58.8	37.9	28.9	188.2	152.3
Queue Length 50th (ft)	~150	195	~370	180	162	~135	~645
Queue Length 95th (ft)	#244	303	#506	285	224	#220	#859
Internal Link Dist (ft)		146	537		636		
Turn Bay Length (ft)	155			270		120	
Base Capacity (vph)	299	884	1188	547	1134	279	812
Starvation Cap Reductn	0	0	0	0	0	0	0
Spillback Cap Reductn	0	0	0	0	0	0	0
Storage Cap Reductn	0	0	0	0	0	0	0
Reduced v/c Ratio	1.31	0.56	1.02	0.62	0.60	1.29	1.27

Intersection Summary

~ Volume exceeds capacity, queue is theoretically infinite.

Queue shown is maximum after two cycles.

# 95th percentile volume exceeds capacity, queue may be longer.

Queue shown is maximum after two cycles.

Queues

General Plan 2040 Project Altern. B Conditions

12: US 101 SB On Ramp/US 101 SB Off Ramp & Old Redwood Highway Timing Plan: Saturday Midday Peak



Lane Group	EBT	EBR	WBL	WBT	SBL	SBT
Lane Group Flow (vph)	735	560	658	1104	268	246
v/c Ratio	0.52	0.65	1.41	0.43	1.10	0.77
Control Delay	17.7	8.7	222.1	4.4	119.2	35.2
Queue Delay	0.0	0.0	0.0	0.0	0.0	0.0
Total Delay	17.7	8.7	222.1	4.4	119.2	35.2
Queue Length 50th (ft)	123	42	~389	77	~141	61
Queue Length 95th (ft)	171	136	#579	105	#202	94
Internal Link Dist (ft)	343			451		751
Turn Bay Length (ft)			250		420	
Base Capacity (vph)	1405	863	467	2568	244	318
Starvation Cap Reductn	0	0	0	0	0	0
Spillback Cap Reductn	0	0	0	0	0	0
Storage Cap Reductn	0	0	0	0	0	0
Reduced v/c Ratio	0.52	0.65	1.41	0.43	1.10	0.77

Intersection Summary

~ Volume exceeds capacity, queue is theoretically infinite.

























Queue shown is maximum after two cycles.

# 95th percentile volume exceeds capacity, queue may be longer.

Queue shown is maximum after two cycles.

HCM 6th Signalized Intersection Summary  
1: Old Redwood Hwy & Shiloh Road

GP 2040+Project Alternative B\_Mitigations  
Timing Plan: A.M. PEAK

												
Movement	EBL	EBT	EBR	WBL	WBT	WBR	NBL	NBT	NBR	SBL	SBT	SBR
Lane Configurations												
Traffic Volume (veh/h)	313	310	440	40	242	29	364	312	18	53	479	398
Future Volume (veh/h)	313	310	440	40	242	29	364	312	18	53	479	398
Initial Q (Qb), veh	0	0	0	0	0	0	0	0	0	0	0	0
Ped-Bike Adj(A_pbT)	1.00		1.00	1.00		1.00	1.00		1.00	1.00		0.99
Parking Bus, Adj	1.00	1.00	1.00	1.00	1.00	1.00	1.00	1.00	1.00	1.00	1.00	1.00
Work Zone On Approach		No			No			No			No	
Adj Sat Flow, veh/h/ln	1870	1870	1870	1870	1870	1870	1870	1870	1870	1870	1870	1870
Adj Flow Rate, veh/h	313	310	440	40	242	29	364	312	18	53	479	398
Peak Hour Factor	1.00	1.00	1.00	1.00	1.00	1.00	1.00	1.00	1.00	1.00	1.00	1.00
Percent Heavy Veh, %	2	2	2	2	2	2	2	2	2	2	2	2
Cap, veh/h	360	1098	490	104	587	262	454	1338	597	104	1078	475
Arrive On Green	0.20	0.31	0.31	0.06	0.17	0.17	0.13	0.38	0.38	0.06	0.30	0.30
Sat Flow, veh/h	1781	3554	1585	1781	3554	1585	3456	3554	1585	1781	3554	1565
Grp Volume(v), veh/h	313	310	440	40	242	29	364	312	18	53	479	398
Grp Sat Flow(s),veh/h/ln	1781	1777	1585	1781	1777	1585	1728	1777	1585	1781	1777	1565
Q Serve(g_s), s	14.6	5.7	22.8	1.9	5.2	1.3	8.8	5.2	0.6	2.5	9.3	20.4
Cycle Q Clear(g_c), s	14.6	5.7	22.8	1.9	5.2	1.3	8.8	5.2	0.6	2.5	9.3	20.4
Prop In Lane	1.00		1.00	1.00		1.00	1.00		1.00	1.00		1.00
Lane Grp Cap(c), veh/h	360	1098	490	104	587	262	454	1338	597	104	1078	475
V/C Ratio(X)	0.87	0.28	0.90	0.39	0.41	0.11	0.80	0.23	0.03	0.51	0.44	0.84
Avail Cap(c_a), veh/h	622	1250	557	788	1581	705	595	1754	782	153	1448	638
HCM Platoon Ratio	1.00	1.00	1.00	1.00	1.00	1.00	1.00	1.00	1.00	1.00	1.00	1.00
Upstream Filter(I)	1.00	1.00	1.00	1.00	1.00	1.00	1.00	1.00	1.00	1.00	1.00	1.00
Uniform Delay (d), s/veh	33.2	22.5	28.4	39.0	32.1	30.5	36.2	18.3	16.9	39.3	24.1	27.9
Incr Delay (d2), s/veh	6.6	0.1	16.1	2.3	0.5	0.2	5.9	0.1	0.0	3.9	0.3	7.3
Initial Q Delay(d3),s/veh	0.0	0.0	0.0	0.0	0.0	0.0	0.0	0.0	0.0	0.0	0.0	0.0
%ile BackOfQ(50%),veh/ln	6.6	2.3	10.1	0.8	2.2	0.5	3.9	2.0	0.2	1.2	3.7	7.9
Unsig. Movement Delay, s/veh												
LnGrp Delay(d),s/veh	39.8	22.6	44.4	41.3	32.6	30.7	42.1	18.4	16.9	43.1	24.4	35.3
LnGrp LOS	D	C	D	D	C	C	D	B	B	D	C	D
Approach Vol, veh/h		1063			311			694			930	
Approach Delay, s/veh		36.7			33.5			30.8			30.1	
Approach LOS		D			C			C			C	
Timer - Assigned Phs	1	2	3	4	5	6	7	8				
Phs Duration (G+Y+Rc), s	9.5	31.0	14.8	30.6	21.9	18.7	8.5	36.8				
Change Period (Y+Rc), s	4.5	4.5	3.5	4.5	4.5	4.5	3.5	4.5				
Max Green Setting (Gmax), s	38.0	30.2	14.8	35.0	30.0	38.2	7.4	42.4				
Max Q Clear Time (g_c+I1), s	3.9	24.8	10.8	22.4	16.6	7.2	4.5	7.2				
Green Ext Time (p_c), s	0.1	1.7	0.5	3.7	0.8	1.6	0.0	2.0				
<b>Intersection Summary</b>												
HCM 6th Ctrl Delay			33.0									
HCM 6th LOS			C									

HCM 6th Signalized Intersection Summary  
2: Shiloh Road & Hembree Ln



Movement	EBL	EBT	EBR	WBL	WBT	WBR	NBL	NBT	NBR	SBL	SBT	SBR
Lane Configurations	↖↗	↑↔		↖↗	↑↔		↖	↗		↖	↑	↗↖
Traffic Volume (veh/h)	311	918	103	49	865	90	49	11	16	129	18	570
Future Volume (veh/h)	311	918	103	49	865	90	49	11	16	129	18	570
Initial Q (Qb), veh	0	0	0	0	0	0	0	0	0	0	0	0
Ped-Bike Adj(A_pbT)	1.00		1.00	1.00		1.00	1.00		1.00	1.00		1.00
Parking Bus, Adj	1.00	1.00	1.00	1.00	1.00	1.00	1.00	1.00	1.00	1.00	1.00	1.00
Work Zone On Approach		No		No		No		No		No		No
Adj Sat Flow, veh/h/ln	1870	1870	1870	1870	1870	1870	1870	1870	1870	1870	1870	1870
Adj Flow Rate, veh/h	353	1043	103	49	892	93	49	11	16	137	18	606
Peak Hour Factor	0.88	0.88	1.00	1.00	0.97	0.97	1.00	1.00	1.00	0.94	1.00	0.94
Percent Heavy Veh, %	2	2	2	2	2	2	2	2	2	2	2	2
Cap, veh/h	481	1559	154	85	1252	131	60	62	90	176	289	819
Arrive On Green	0.14	0.48	0.48	0.05	0.39	0.39	0.03	0.09	0.09	0.10	0.15	0.15
Sat Flow, veh/h	3456	3267	322	1781	3248	339	1781	689	1002	1781	1870	2790
Grp Volume(v), veh/h	353	567	579	49	488	497	49	0	27	137	18	606
Grp Sat Flow(s),veh/h/ln	1728	1777	1812	1781	1777	1809	1781	0	1690	1781	1870	1395
Q Serve(g_s), s	5.5	13.7	13.7	1.5	13.0	13.0	1.5	0.0	0.8	4.2	0.5	8.6
Cycle Q Clear(g_c), s	5.5	13.7	13.7	1.5	13.0	13.0	1.5	0.0	0.8	4.2	0.5	8.6
Prop In Lane	1.00		0.18	1.00		0.19	1.00		0.59	1.00		1.00
Lane Grp Cap(c), veh/h	481	848	865	85	685	698	60	0	152	176	289	819
V/C Ratio(X)	0.73	0.67	0.67	0.58	0.71	0.71	0.81	0.00	0.18	0.78	0.06	0.74
Avail Cap(c_a), veh/h	620	1402	1430	208	1291	1314	208	0	167	256	289	819
HCM Platoon Ratio	1.00	1.00	1.00	1.00	1.00	1.00	1.00	1.00	1.00	1.00	1.00	1.00
Upstream Filter(I)	1.00	1.00	1.00	1.00	1.00	1.00	1.00	0.00	1.00	1.00	1.00	1.00
Uniform Delay (d), s/veh	23.0	11.2	11.2	26.0	14.5	14.5	26.8	0.0	23.5	24.5	20.1	17.8
Incr Delay (d2), s/veh	3.3	0.9	0.9	6.0	1.4	1.4	22.4	0.0	0.6	9.1	0.1	3.6
Initial Q Delay(d3),s/veh	0.0	0.0	0.0	0.0	0.0	0.0	0.0	0.0	0.0	0.0	0.0	0.0
%ile BackOfQ(50%),veh/ln	2.2	4.2	4.3	0.7	4.4	4.5	1.0	0.0	0.3	2.1	0.2	3.5
Unsig. Movement Delay, s/veh												
LnGrp Delay(d),s/veh	26.3	12.1	12.1	32.0	15.9	15.9	49.1	0.0	24.0	33.6	20.2	21.4
LnGrp LOS	C	B	B	C	B	B	D	A	C	C	C	C
Approach Vol, veh/h		1499			1034			76			761	
Approach Delay, s/veh		15.4			16.6			40.2			23.5	
Approach LOS		B			B			D			C	
Timer - Assigned Phs	1	2	3	4	5	6	7	8				
Phs Duration (G+Y+Rc), s	6.7	30.6	5.9	12.6	11.8	25.5	9.5	9.0				
Change Period (Y+Rc), s	4.0	4.0	4.0	4.0	4.0	4.0	4.0	4.0				
Max Green Setting (Gmax), s	6.5	44.0	6.5	7.0	10.0	40.5	8.0	5.5				
Max Q Clear Time (g_c+1), s	13.5	15.7	3.5	10.6	7.5	15.0	6.2	2.8				
Green Ext Time (p_c), s	0.0	8.3	0.0	0.0	0.3	6.5	0.1	0.0				
<b>Intersection Summary</b>												
HCM 6th Ctrl Delay				18.2								
HCM 6th LOS				B								

HCM 6th Signalized Intersection Summary  
 3: US 101 NB Off-Ramp & Shiloh Road

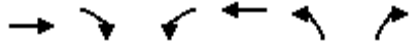

Movement	EBT	EBR	WBL	WBT	NBL	NBR
Lane Configurations	↑↑			↑↑	↘	↗↗
Traffic Volume (veh/h)	731	0	0	1103	813	602
Future Volume (veh/h)	731	0	0	1103	813	602
Initial Q (Qb), veh	0	0	0	0	0	0
Ped-Bike Adj(A_pbT)		1.00	1.00		1.00	1.00
Parking Bus, Adj	1.00	1.00	1.00	1.00	1.00	1.00
Work Zone On Approach	No			No	No	
Adj Sat Flow, veh/h/ln	1870	0	0	1870	1870	1870
Adj Flow Rate, veh/h	803	0	0	1226	1070	792
Peak Hour Factor	0.91	0.91	0.90	0.90	0.76	0.76
Percent Heavy Veh, %	2	0	0	2	2	2
Cap, veh/h	1199	0	0	1199	1002	1569
Arrive On Green	0.34	0.00	0.00	0.34	0.56	0.56
Sat Flow, veh/h	3741	0	0	3741	1781	2790
Grp Volume(v), veh/h	803	0	0	1226	1070	792
Grp Sat Flow(s),veh/h/ln1777		0	0	1777	1781	1395
Q Serve(g_s), s	15.5	0.0	0.0	27.0	45.0	13.9
Cycle Q Clear(g_c), s	15.5	0.0	0.0	27.0	45.0	13.9
Prop In Lane		0.00	0.00		1.00	1.00
Lane Grp Cap(c), veh/h	1199	0	0	1199	1002	1569
V/C Ratio(X)	0.67	0.00	0.00	1.02	1.07	0.50
Avail Cap(c_a), veh/h	1199	0	0	1199	1002	1569
HCM Platoon Ratio	1.00	1.00	1.00	1.00	1.00	1.00
Upstream Filter(I)	1.00	0.00	0.00	1.00	1.00	1.00
Uniform Delay (d), s/veh	22.7	0.0	0.0	26.5	17.5	10.7
Incr Delay (d2), s/veh	1.5	0.0	0.0	31.7	48.4	0.3
Initial Q Delay(d3),s/veh	0.0	0.0	0.0	0.0	0.0	0.0
%ile BackOfQ(50%),veh/ln6.1		0.0	0.0	15.6	29.1	3.8
Unsig. Movement Delay, s/veh						
LnGrp Delay(d),s/veh	24.1	0.0	0.0	58.2	65.9	11.0
LnGrp LOS	C	A	A	F	F	B
Approach Vol, veh/h	803			1226	1862	
Approach Delay, s/veh	24.1			58.2	42.5	
Approach LOS	C			E	D	
Timer - Assigned Phs		2			6	8
Phs Duration (G+Y+Rc), s		31.0			31.0	49.0
Change Period (Y+Rc), s		4.0			4.0	4.0
Max Green Setting (Gmax), s		27.0			27.0	45.0
Max Q Clear Time (g_c+I1), s		17.5			29.0	47.0
Green Ext Time (p_c), s		3.6			0.0	0.0

Intersection Summary

HCM 6th Ctrl Delay	43.7
HCM 6th LOS	D

Intersection						
Int Delay, s/veh	2.5					
Movement	EBT	EBR	WBL	WBT	NBL	NBR
Lane Configurations	↑↑		↘	↑↑	↘	↘
Traffic Vol, veh/h	900	14	130	1207	17	122
Future Vol, veh/h	900	14	130	1207	17	122
Conflicting Peds, #/hr	0	0	0	0	0	0
Sign Control	Free	Free	Free	Free	Stop	Stop
RT Channelized	-	None	-	None	-	None
Storage Length	-	-	68	-	0	0
Veh in Median Storage, #	0	-	-	0	0	-
Grade, %	0	-	-	0	0	-
Peak Hour Factor	96	96	87	87	84	84
Heavy Vehicles, %	2	2	2	2	2	2
Mvmt Flow	938	15	149	1387	20	145

Major/Minor	Major1	Major2	Minor1		
Conflicting Flow All	0	0	953	0	1938 477
Stage 1	-	-	-	-	946 -
Stage 2	-	-	-	-	992 -
Critical Hdwy	-	-	4.14	-	6.84 6.94
Critical Hdwy Stg 1	-	-	-	-	5.84 -
Critical Hdwy Stg 2	-	-	-	-	5.84 -
Follow-up Hdwy	-	-	2.22	-	3.52 3.32
Pot Cap-1 Maneuver	-	-	717	-	57 534
Stage 1	-	-	-	-	338 -
Stage 2	-	-	-	-	320 -
Platoon blocked, %	-	-	-	-	-
Mov Cap-1 Maneuver	-	-	717	-	45 534
Mov Cap-2 Maneuver	-	-	-	-	45 -
Stage 1	-	-	-	-	338 -
Stage 2	-	-	-	-	253 -

Approach	EB	WB	NB
HCM Control Delay, s	0	1.1	29.4
HCM LOS			D

Minor Lane/Major Mvmt	NBLn1	NBLn2	EBT	EBR	WBL	WBT
Capacity (veh/h)	45	534	-	-	717	-
HCM Lane V/C Ratio	0.45	0.272	-	-	0.208	-
HCM Control Delay (s)	138.7	14.2	-	-	11.3	-
HCM Lane LOS	F	B	-	-	B	-
HCM 95th %tile Q(veh)	1.6	1.1	-	-	0.8	-



HCM Signalized Intersection Capacity Analysis  
6: Conde Lane & Shiloh Road

GP 2040+Project Alternative B\_Mitigations  
Timing Plan: A.M. PEAK

Movement	EBL	EBT	EBR	WBL	WBT	WBR	NBL	NBT	NBR	SBL	SBT	SBR
Lane Configurations												
Traffic Volume (vph)	55	535	3	8	854	298	2	1	9	363	0	27
Future Volume (vph)	55	535	3	8	854	298	2	1	9	363	0	27
Ideal Flow (vphpl)	1900	1900	1900	1900	1900	1900	1900	1900	1900	1900	1900	1900
Total Lost time (s)	4.0	4.0		4.0	4.0			4.0			4.0	4.0
Lane Util. Factor	1.00	0.95		1.00	0.95			1.00			1.00	1.00
Frt	1.00	1.00		1.00	0.96			0.90			1.00	0.85
Flt Protected	0.95	1.00		0.95	1.00			0.99			0.95	1.00
Satd. Flow (prot)	1770	3536		1770	3402			1665			1770	1583
Flt Permitted	0.95	1.00		0.95	1.00			0.99			0.95	1.00
Satd. Flow (perm)	1770	3536		1770	3402			1665			1770	1583
Peak-hour factor, PHF	0.95	0.95	0.95	0.85	0.85	0.85	0.57	0.57	0.57	0.86	0.86	0.86
Adj. Flow (vph)	58	563	3	9	1005	351	4	2	16	422	0	31
RTOR Reduction (vph)	0	0	0	0	20	0	0	15	0	0	0	0
Lane Group Flow (vph)	58	566	0	9	1336	0	0	7	0	0	422	31
Turn Type	Prot	NA		Prot	NA		Split	NA		Split	NA	custom
Protected Phases	5	2		1	6		7	7		4	4	
Permitted Phases												6
Actuated Green, G (s)	6.2	59.6		1.5	54.9			3.6			31.3	54.9
Effective Green, g (s)	6.2	59.6		1.5	54.9			3.6			31.3	54.9
Actuated g/C Ratio	0.06	0.53		0.01	0.49			0.03			0.28	0.49
Clearance Time (s)	4.0	4.0		4.0	4.0			4.0			4.0	4.0
Vehicle Extension (s)	3.0	3.0		3.0	3.0			3.0			3.0	3.0
Lane Grp Cap (vph)	97	1881		23	1667			53			494	775
v/s Ratio Prot	c0.03	0.16		0.01	c0.39			c0.00			c0.24	
v/s Ratio Perm												0.02
v/c Ratio	0.60	0.30		0.39	0.80			0.12			0.85	0.04
Uniform Delay, d1	51.7	14.6		54.8	24.0			52.7			38.2	14.8
Progression Factor	1.00	1.00		1.00	1.00			1.00			1.00	1.00
Incremental Delay, d2	9.5	0.1		10.7	2.9			1.0			13.5	0.0
Delay (s)	61.2	14.7		65.5	26.8			53.7			51.7	14.9
Level of Service	E	B		E	C			D			D	B
Approach Delay (s)		19.0			27.1			53.7			49.1	
Approach LOS		B			C			D			D	
<b>Intersection Summary</b>												
HCM 2000 Control Delay			29.3			HCM 2000 Level of Service				C		
HCM 2000 Volume to Capacity ratio			0.78									
Actuated Cycle Length (s)			112.0			Sum of lost time (s)			16.0			
Intersection Capacity Utilization			76.6%			ICU Level of Service				D		
Analysis Period (min)			15									

c Critical Lane Group

HCM 6th Signalized Intersection Summary  
8: Old Redwood Hwy & Driveway 2

GP 2040+Project Alternative B\_Mitigations  
Timing Plan: A.M. PEAK



Movement	EBL	EBT	EBR	WBL	WBT	WBR	NBL	NBT	NBR	SBL	SBT	SBR
Lane Configurations		↔		↵	↵			↗	↗	↘	↘	
Traffic Volume (veh/h)	1	0	0	19	0	31	0	662	28	45	914	0
Future Volume (veh/h)	1	0	0	19	0	31	0	662	28	45	914	0
Initial Q (Qb), veh	0	0	0	0	0	0	0	0	0	0	0	0
Ped-Bike Adj(A_pbT)	1.00		1.00	1.00		1.00	1.00		0.99	1.00		1.00
Parking Bus, Adj	1.00	1.00	1.00	1.00	1.00	1.00	1.00	1.00	1.00	1.00	1.00	1.00
Work Zone On Approach		No			No			No			No	
Adj Sat Flow, veh/h/ln	1870	1870	1870	1870	1870	1870	1870	1870	1870	1870	1870	1870
Adj Flow Rate, veh/h	4	0	0	19	0	31	0	669	28	50	1016	0
Peak Hour Factor	0.25	0.25	0.25	1.00	1.00	1.00	0.99	0.99	0.99	0.90	0.90	0.90
Percent Heavy Veh, %	2	2	2	2	2	2	2	2	2	2	2	2
Cap, veh/h	287	0	0	324	0	173	0	1226	1026	508	1226	0
Arrive On Green	0.11	0.00	0.00	0.11	0.00	0.11	0.00	0.66	0.66	0.66	0.66	0.00
Sat Flow, veh/h	1154	0	0	1418	0	1585	0	1870	1565	748	1870	0
Grp Volume(v), veh/h	4	0	0	19	0	31	0	669	28	50	1016	0
Grp Sat Flow(s),veh/h/ln	1154	0	0	1418	0	1585	0	1870	1565	748	1870	0
Q Serve(g_s), s	0.1	0.0	0.0	0.0	0.0	0.8	0.0	8.6	0.3	1.7	18.3	0.0
Cycle Q Clear(g_c), s	0.9	0.0	0.0	0.4	0.0	0.8	0.0	8.6	0.3	10.3	18.3	0.0
Prop In Lane	1.00		0.00	1.00		1.00	0.00		1.00	1.00		0.00
Lane Grp Cap(c), veh/h	287	0	0	324	0	173	0	1226	1026	508	1226	0
V/C Ratio(X)	0.01	0.00	0.00	0.06	0.00	0.18	0.00	0.55	0.03	0.10	0.83	0.00
Avail Cap(c_a), veh/h	692	0	0	740	0	639	0	1947	1629	796	1947	0
HCM Platoon Ratio	1.00	1.00	1.00	1.00	1.00	1.00	1.00	1.00	1.00	1.00	1.00	1.00
Upstream Filter(I)	1.00	0.00	0.00	1.00	0.00	1.00	0.00	1.00	1.00	1.00	1.00	0.00
Uniform Delay (d), s/veh	18.5	0.0	0.0	17.9	0.0	18.1	0.0	4.1	2.7	6.9	5.8	0.0
Incr Delay (d2), s/veh	0.0	0.0	0.0	0.1	0.0	0.5	0.0	0.4	0.0	0.1	1.7	0.0
Initial Q Delay(d3), s/veh	0.0	0.0	0.0	0.0	0.0	0.0	0.0	0.0	0.0	0.0	0.0	0.0
%ile BackOfQ(50%),veh/ln	0.0	0.0	0.0	0.2	0.0	0.3	0.0	0.9	0.0	0.2	2.2	0.0
Unsig. Movement Delay, s/veh												
LnGrp Delay(d), s/veh	18.5	0.0	0.0	18.0	0.0	18.6	0.0	4.5	2.7	7.0	7.5	0.0
LnGrp LOS	B			B		B		A	A	A	A	
Approach Vol, veh/h		4			50			697			1066	
Approach Delay, s/veh		18.5			18.3			4.4			7.5	
Approach LOS		B			B			A			A	
Timer - Assigned Phs		2		4		6		8				
Phs Duration (G+Y+Rc), s		35.1		9.6		35.1		9.6				
Change Period (Y+Rc), s		5.8		4.7		5.8		4.7				
Max Green Setting (Gmax), s		46.5		18.0		46.5		18.0				
Max Q Clear Time (g_c+I1), s		10.6		2.9		20.3		2.8				
Green Ext Time (p_c), s		4.7		0.0		9.0		0.1				
<b>Intersection Summary</b>												
HCM 6th Ctrl Delay, s/veh				6.7								
HCM 6th LOS				A								
<b>Notes</b>												
User approved changes to right turn type.												

HCM 6th Signalized Intersection Summary

GP 2040+Project Alternative B\_Mitigations

12: US 101 SB On Ramp/US 101 SB Off Ramp & Old Redwood Highway

Timing Plan: A.M. PEAK



Movement	EBL	EBT	EBR	WBL	WBT	WBR	NBL	NBT	NBR	SBL	SBT	SBR
Lane Configurations		↑↑	↑	↑	↑↑					↑	↑	
Traffic Volume (veh/h)	0	699	814	559	742	0	0	0	0	185	0	144
Future Volume (veh/h)	0	699	814	559	742	0	0	0	0	185	0	144
Initial Q (Qb), veh	0	0	0	0	0	0				0	0	0
Ped-Bike Adj(A_pbT)	1.00		0.99	1.00		1.00				1.00		1.00
Parking Bus, Adj	1.00	1.00	1.00	1.00	1.00	1.00				1.00	1.00	1.00
Work Zone On Approach		No			No						No	
Adj Sat Flow, veh/h/ln	0	1870	1870	1870	1870	0				1870	1870	1870
Adj Flow Rate, veh/h	0	699	814	559	742	0				164	29	0
Peak Hour Factor	1.00	1.00	1.00	1.00	1.00	1.00				1.00	1.00	1.00
Percent Heavy Veh, %	0	2	2	2	2	0				2	2	2
Cap, veh/h	0	1588	698	600	2914	0				162	170	
Arrive On Green	0.00	0.45	0.45	0.34	0.82	0.00				0.09	0.09	0.00
Sat Flow, veh/h	0	3647	1561	1781	3647	0				1781	1870	0
Grp Volume(v), veh/h	0	699	814	559	742	0				164	29	0
Grp Sat Flow(s),veh/h/ln	0	1777	1561	1781	1777	0				1781	1870	0
Q Serve(g_s), s	0.0	14.9	49.2	33.4	5.2	0.0				10.0	1.6	0.0
Cycle Q Clear(g_c), s	0.0	14.9	49.2	33.4	5.2	0.0				10.0	1.6	0.0
Prop In Lane	0.00		1.00	1.00		0.00				1.00		0.00
Lane Grp Cap(c), veh/h	0	1588	698	600	2914	0				162	170	
V/C Ratio(X)	0.00	0.44	1.17	0.93	0.25	0.00				1.01	0.17	
Avail Cap(c_a), veh/h	0	1588	698	823	2914	0				162	170	
HCM Platoon Ratio	1.00	1.00	1.00	1.00	1.00	1.00				1.00	1.00	1.00
Upstream Filter(I)	0.00	1.00	1.00	1.00	1.00	0.00				1.00	1.00	0.00
Uniform Delay (d), s/veh	0.0	20.9	30.4	35.3	2.3	0.0				50.0	46.2	0.0
Incr Delay (d2), s/veh	0.0	0.9	90.1	14.0	0.2	0.0				74.1	0.5	0.0
Initial Q Delay(d3),s/veh	0.0	0.0	0.0	0.0	0.0	0.0				0.0	0.0	0.0
%ile BackOfQ(50%),veh/ln	0.0	6.2	34.9	16.3	1.2	0.0				7.8	0.8	0.0
Unsig. Movement Delay, s/veh												
LnGrp Delay(d),s/veh	0.0	21.8	120.5	49.3	2.5	0.0				124.1	46.6	0.0
LnGrp LOS		A	C	F	D	A				F	D	
Approach Vol, veh/h		1513			1301					193		
Approach Delay, s/veh		74.9			22.6					112.5		
Approach LOS		E			C					F		
Timer - Assigned Phs		2			5	6		8				
Phs Duration (G+Y+Rc), s		95.3			41.0	54.3		14.7				
Change Period (Y+Rc), s		5.1			4.0	5.1		4.7				
Max Green Setting (Gmax), s		90.2			50.8	35.4		10.0				
Max Q Clear Time (g_c+11), s		7.2			35.4	51.2		12.0				
Green Ext Time (p_c), s		6.0			1.7	0.0		0.0				

Intersection Summary

























HCM 6th Ctrl Delay	54.7
HCM 6th LOS	D

Notes

- User approved volume balancing among the lanes for turning movement.
- User approved ignoring U-Turning movement.
- Unsignalized Delay for [SBR] is excluded from calculations of the approach delay and intersection delay.

HCM 6th Signalized Intersection Summary  
 1: Old Redwood Hwy & Shiloh Road

GP 2040+Project Alternative B\_Mitigations  
 Timing Plan: P.M. Peak

												
Movement	EBL	EBT	EBR	WBL	WBT	WBR	NBL	NBT	NBR	SBL	SBT	SBR
Lane Configurations												
Traffic Volume (veh/h)	317	398	635	44	393	64	656	565	44	79	545	265
Future Volume (veh/h)	317	398	635	44	393	64	656	565	44	79	545	265
Initial Q (Qb), veh	0	0	0	0	0	0	0	0	0	0	0	0
Ped-Bike Adj(A_pbT)	1.00		1.00	1.00		1.00	1.00		0.98	1.00		0.98
Parking Bus, Adj	1.00	1.00	1.00	1.00	1.00	1.00	1.00	1.00	1.00	1.00	1.00	1.00
Work Zone On Approach		No			No			No			No	
Adj Sat Flow, veh/h/ln	1870	1870	1870	1870	1870	1870	1870	1870	1870	1870	1870	1870
Adj Flow Rate, veh/h	317	398	635	44	393	64	656	565	44	79	545	265
Peak Hour Factor	1.00	1.00	1.00	1.00	1.00	1.00	1.00	1.00	1.00	1.00	1.00	1.00
Percent Heavy Veh, %	2	2	2	2	2	2	2	2	2	2	2	2
Cap, veh/h	359	1169	521	93	639	285	744	1337	582	116	804	353
Arrive On Green	0.20	0.33	0.33	0.05	0.18	0.18	0.22	0.38	0.38	0.07	0.23	0.23
Sat Flow, veh/h	1781	3554	1583	1781	3554	1582	3456	3554	1547	1781	3554	1559
Grp Volume(v), veh/h	317	398	635	44	393	64	656	565	44	79	545	265
Grp Sat Flow(s),veh/h/ln	1781	1777	1583	1781	1777	1582	1728	1777	1547	1781	1777	1559
Q Serve(g_s), s	16.6	8.1	31.5	2.3	9.8	3.3	17.6	11.3	1.7	4.2	13.4	15.2
Cycle Q Clear(g_c), s	16.6	8.1	31.5	2.3	9.8	3.3	17.6	11.3	1.7	4.2	13.4	15.2
Prop In Lane	1.00		1.00	1.00		1.00	1.00		1.00	1.00		1.00
Lane Grp Cap(c), veh/h	359	1169	521	93	639	285	744	1337	582	116	804	353
V/C Ratio(X)	0.88	0.34	1.22	0.47	0.61	0.22	0.88	0.42	0.08	0.68	0.68	0.75
Avail Cap(c_a), veh/h	558	1169	521	707	1466	653	848	1670	727	251	1299	570
HCM Platoon Ratio	1.00	1.00	1.00	1.00	1.00	1.00	1.00	1.00	1.00	1.00	1.00	1.00
Upstream Filter(I)	1.00	1.00	1.00	1.00	1.00	1.00	1.00	1.00	1.00	1.00	1.00	1.00
Uniform Delay (d), s/veh	37.2	24.3	32.1	44.1	36.2	33.6	36.4	22.1	19.2	43.8	33.9	34.5
Incr Delay (d2), s/veh	10.3	0.2	115.4	3.7	1.0	0.4	9.9	0.2	0.1	6.8	1.0	3.2
Initial Q Delay(d3),s/veh	0.0	0.0	0.0	0.0	0.0	0.0	0.0	0.0	0.0	0.0	0.0	0.0
%ile BackOfQ(50%),veh/ln	7.9	3.3	27.8	1.1	4.2	1.2	8.0	4.4	0.6	2.0	5.7	5.8
Unsig. Movement Delay, s/veh												
LnGrp Delay(d),s/veh	47.5	24.5	147.5	47.8	37.2	34.0	46.3	22.4	19.2	50.6	34.9	37.8
LnGrp LOS	D	C	F	D	D	C	D	C	B	D	C	D
Approach Vol, veh/h		1350			501			1265			889	
Approach Delay, s/veh		87.8			37.7			34.7			37.1	
Approach LOS		F			D			C			D	
Timer - Assigned Phs	1	2	3	4	5	6	7	8				
Phs Duration (G+Y+Rc), s	9.5	36.0	24.1	26.2	23.8	21.7	9.7	40.5				
Change Period (Y+Rc), s	4.5	4.5	3.5	4.5	4.5	4.5	3.5	4.5				
Max Green Setting (Gmax), s	38.0	31.5	23.5	35.0	30.0	39.5	13.5	45.0				
Max Q Clear Time (g_c+I1), s	4.3	33.5	19.6	17.2	18.6	11.8	6.2	13.3				
Green Ext Time (p_c), s	0.1	0.0	1.0	4.1	0.7	2.7	0.1	3.8				
<b>Intersection Summary</b>												
HCM 6th Ctrl Delay			53.5									
HCM 6th LOS			D									

HCM 6th Signalized Intersection Summary  
2: Shiloh Road & Hembree Ln

GP 2040+Project Alternative B\_Mitigations  
Timing Plan: P.M. Peak



Movement	EBL	EBT	EBR	WBL	WBT	WBR	NBL	NBT	NBR	SBL	SBT	SBR
Lane Configurations												
Traffic Volume (veh/h)	661	1147	69	110	1086	118	111	21	128	174	11	526
Future Volume (veh/h)	661	1147	69	110	1086	118	111	21	128	174	11	526
Initial Q (Qb), veh	0	0	0	0	0	0	0	0	0	0	0	0
Ped-Bike Adj(A_pbT)	1.00		1.00	1.00		1.00	1.00		1.00	1.00		1.00
Parking Bus, Adj	1.00	1.00	1.00	1.00	1.00	1.00	1.00	1.00	1.00	1.00	1.00	1.00
Work Zone On Approach		No			No			No			No	
Adj Sat Flow, veh/h/ln	1870	1870	1870	1870	1870	1870	1870	1870	1870	1870	1870	1870
Adj Flow Rate, veh/h	703	1220	69	110	1248	136	111	21	128	183	11	554
Peak Hour Factor	0.94	0.94	1.00	1.00	0.87	0.87	1.00	1.00	1.00	0.95	1.00	0.95
Percent Heavy Veh, %	2	2	2	2	2	2	2	2	2	2	2	2
Cap, veh/h	727	1925	109	140	1394	151	150	14	87	203	173	845
Arrive On Green	0.21	0.56	0.56	0.08	0.43	0.43	0.08	0.06	0.06	0.11	0.09	0.09
Sat Flow, veh/h	3456	3419	193	1781	3232	351	1781	228	1392	1781	1870	2790
Grp Volume(v), veh/h	703	633	656	110	684	700	111	0	149	183	11	554
Grp Sat Flow(s),veh/h/ln	1728	1777	1835	1781	1777	1807	1781	0	1620	1781	1870	1395
Q Serve(g_s), s	17.7	21.3	21.3	5.3	31.3	31.6	5.4	0.0	5.5	8.9	0.5	8.1
Cycle Q Clear(g_c), s	17.7	21.3	21.3	5.3	31.3	31.6	5.4	0.0	5.5	8.9	0.5	8.1
Prop In Lane	1.00		0.11	1.00		0.19	1.00		0.86	1.00		1.00
Lane Grp Cap(c), veh/h	727	1000	1033	140	766	779	150	0	101	203	173	845
V/C Ratio(X)	0.97	0.63	0.63	0.78	0.89	0.90	0.74	0.00	1.47	0.90	0.06	0.66
Avail Cap(c_a), veh/h	727	1000	1033	245	809	822	176	0	101	203	173	845
HCM Platoon Ratio	1.00	1.00	1.00	1.00	1.00	1.00	1.00	1.00	1.00	1.00	1.00	1.00
Upstream Filter(I)	1.00	1.00	1.00	1.00	1.00	1.00	1.00	0.00	1.00	1.00	1.00	1.00
Uniform Delay (d), s/veh	34.4	13.0	13.1	39.8	23.1	23.2	39.3	0.0	41.2	38.5	36.4	26.7
Incr Delay (d2), s/veh	25.3	1.3	1.3	9.2	11.9	12.3	13.0	0.0	257.2	37.7	0.2	1.8
Initial Q Delay(d3),s/veh	0.0	0.0	0.0	0.0	0.0	0.0	0.0	0.0	0.0	0.0	0.0	0.0
%ile BackOfQ(50%),veh/ln	0.6	7.6	7.9	2.6	14.2	14.7	2.8	0.0	9.4	5.9	0.2	5.1
Unsig. Movement Delay, s/veh												
LnGrp Delay(d),s/veh	59.7	14.4	14.3	49.0	35.0	35.6	52.4	0.0	298.4	76.1	36.6	28.5
LnGrp LOS	E	B	B	D	D	D	D	A	F	E	D	C
Approach Vol, veh/h		1992			1494			260			748	
Approach Delay, s/veh		30.3			36.3			193.4			40.3	
Approach LOS		C			D			F			D	
Timer - Assigned Phs	1	2	3	4	5	6	7	8				
Phs Duration (G+Y+Rc), s	10.9	53.5	11.4	12.1	22.5	41.9	14.0	9.5				
Change Period (Y+Rc), s	4.0	4.0	4.0	4.0	4.0	4.0	4.0	4.0				
Max Green Setting (Gmax), s	12.5	46.4	8.7	6.8	18.5	40.0	10.0	5.5				
Max Q Clear Time (g_c+1), s	17.3	23.3	7.4	10.1	19.7	33.6	10.9	7.5				
Green Ext Time (p_c), s	0.1	9.0	0.0	0.0	0.0	4.2	0.0	0.0				

Intersection Summary

HCM 6th Ctrl Delay	43.4
HCM 6th LOS	D

HCM 6th Signalized Intersection Summary  
 3: US 101 NB Off-Ramp & Shiloh Road

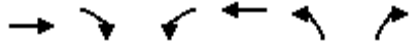

Movement	EBT	EBR	WBL	WBT	NBL	NBR
Lane Configurations	↑↑			↑↑	↘	↗↗
Traffic Volume (veh/h)	895	0	0	1079	694	939
Future Volume (veh/h)	895	0	0	1079	694	939
Initial Q (Qb), veh	0	0	0	0	0	0
Ped-Bike Adj(A_pbT)		1.00	1.00		1.00	1.00
Parking Bus, Adj	1.00	1.00	1.00	1.00	1.00	1.00
Work Zone On Approach	No			No	No	
Adj Sat Flow, veh/h/ln	1870	0	0	1870	1870	1870
Adj Flow Rate, veh/h	952	0	0	1112	771	1043
Peak Hour Factor	0.94	0.94	0.97	0.97	0.90	0.90
Percent Heavy Veh, %	2	0	0	2	2	2
Cap, veh/h	1285	0	0	1285	866	1357
Arrive On Green	0.36	0.00	0.00	0.36	0.49	0.49
Sat Flow, veh/h	3741	0	0	3741	1781	2790
Grp Volume(v), veh/h	952	0	0	1112	771	1043
Grp Sat Flow(s),veh/h/ln	1777	0	0	1777	1781	1395
Q Serve(g_s), s	12.3	0.0	0.0	15.3	20.6	16.2
Cycle Q Clear(g_c), s	12.3	0.0	0.0	15.3	20.6	16.2
Prop In Lane		0.00	0.00		1.00	1.00
Lane Grp Cap(c), veh/h	1285	0	0	1285	866	1357
V/C Ratio(X)	0.74	0.00	0.00	0.87	0.89	0.77
Avail Cap(c_a), veh/h	1349	0	0	1349	913	1430
HCM Platoon Ratio	1.00	1.00	1.00	1.00	1.00	1.00
Upstream Filter(I)	1.00	0.00	0.00	1.00	1.00	1.00
Uniform Delay (d), s/veh	14.7	0.0	0.0	15.6	12.3	11.1
Incr Delay (d2), s/veh	2.1	0.0	0.0	5.9	10.5	2.5
Initial Q Delay(d3),s/veh	0.0	0.0	0.0	0.0	0.0	0.0
%ile BackOfQ(50%),veh/ln	4.3	0.0	0.0	5.9	8.8	4.3
Unsig. Movement Delay, s/veh						
LnGrp Delay(d),s/veh	16.8	0.0	0.0	21.5	22.7	13.6
LnGrp LOS	B	A	A	C	C	B
Approach Vol, veh/h	952			1112	1814	
Approach Delay, s/veh	16.8			21.5	17.5	
Approach LOS	B			C	B	
Timer - Assigned Phs		2			6	8
Phs Duration (G+Y+Rc), s		23.1			23.1	29.6
Change Period (Y+Rc), s		4.0			4.0	4.0
Max Green Setting (Gmax), s		20.0			20.0	27.0
Max Q Clear Time (g_c+I1), s		14.3			17.3	22.6
Green Ext Time (p_c), s		2.9			1.7	3.0
<b>Intersection Summary</b>						
HCM 6th Ctrl Delay			18.5			
HCM 6th LOS			B			

Intersection						
Int Delay, s/veh	2.5					
Movement	EBT	EBR	WBL	WBT	NBL	NBR
Lane Configurations	↑↑		↖	↑↑	↖	↖
Traffic Vol, veh/h	1201	16	105	1139	18	159
Future Vol, veh/h	1201	16	105	1139	18	159
Conflicting Peds, #/hr	0	0	0	0	0	0
Sign Control	Free	Free	Free	Free	Stop	Stop
RT Channelized	-	None	-	None	-	None
Storage Length	-	-	68	-	0	0
Veh in Median Storage, #	0	-	-	0	0	-
Grade, %	0	-	-	0	0	-
Peak Hour Factor	100	100	100	100	100	100
Heavy Vehicles, %	2	2	2	2	2	2
Mvmt Flow	1201	16	105	1139	18	159

Major/Minor	Major1	Major2	Minor1		
Conflicting Flow All	0	0	1217	0	1989 609
Stage 1	-	-	-	-	1209 -
Stage 2	-	-	-	-	780 -
Critical Hdwy	-	-	4.14	-	6.84 6.94
Critical Hdwy Stg 1	-	-	-	-	5.84 -
Critical Hdwy Stg 2	-	-	-	-	5.84 -
Follow-up Hdwy	-	-	2.22	-	3.52 3.32
Pot Cap-1 Maneuver	-	-	569	-	53 438
Stage 1	-	-	-	-	245 -
Stage 2	-	-	-	-	412 -
Platoon blocked, %	-	-	-	-	-
Mov Cap-1 Maneuver	-	-	569	-	43 438
Mov Cap-2 Maneuver	-	-	-	-	43 -
Stage 1	-	-	-	-	245 -
Stage 2	-	-	-	-	336 -

Approach	EB	WB	NB
HCM Control Delay, s	0	1.1	30.1
HCM LOS			D

Minor Lane/Major Mvmt	NBLn1	NBLn2	EBT	EBR	WBL	WBT
Capacity (veh/h)	43	438	-	-	569	-
HCM Lane V/C Ratio	0.419	0.363	-	-	0.185	-
HCM Control Delay (s)	139.2	17.8	-	-	12.8	-
HCM Lane LOS	F	C	-	-	B	-
HCM 95th %tile Q(veh)	1.5	1.6	-	-	0.7	-

HCM Signalized Intersection Capacity Analysis  
6: Conde Lane & Shiloh Road



















GP 2040+Project Alternative B\_Mitigations  
Timing Plan: P.M. Peak

Movement	EBL	EBT	EBR	WBL	WBT	WBR	NBL	NBT	NBR	SBL	SBT	SBR
Lane Configurations												
Traffic Volume (vph)	77	724	0	9	743	372	4	2	16	387	4	65
Future Volume (vph)	77	724	0	9	743	372	4	2	16	387	4	65
Ideal Flow (vphpl)	1900	1900	1900	1900	1900	1900	1900	1900	1900	1900	1900	1900
Total Lost time (s)	4.0	4.0		4.0	4.0			4.0			4.0	4.0
Lane Util. Factor	1.00	0.95		1.00	0.95			1.00			1.00	1.00
Frbp, ped/bikes	1.00	1.00		1.00	0.99			1.00			1.00	1.00
Flpb, ped/bikes	1.00	1.00		1.00	1.00			1.00			1.00	1.00
Frt	1.00	1.00		1.00	0.95			0.90			1.00	0.85
Flt Protected	0.95	1.00		0.95	1.00			0.99			0.95	1.00
Satd. Flow (prot)	1770	3539		1770	3339			1663			1775	1583
Flt Permitted	0.95	1.00		0.95	1.00			0.99			0.95	1.00
Satd. Flow (perm)	1770	3539		1770	3339			1663			1775	1583
Peak-hour factor, PHF	0.88	0.88	0.88	0.80	0.80	0.80	0.63	0.63	0.63	0.88	0.88	0.88
Adj. Flow (vph)	88	823	0	11	929	465	6	3	25	440	5	74
RTOR Reduction (vph)	0	0	0	0	35	0	0	24	0	0	0	0
Lane Group Flow (vph)	88	823	0	11	1359	0	0	10	0	0	445	74
Confl. Peds. (#/hr)	1						1					
Turn Type	Prot	NA		Prot	NA		Split	NA		Split	NA	custom
Protected Phases	5	2		1	6		7	7		4	4	
Permitted Phases												6
Actuated Green, G (s)	8.0	66.9		1.5	60.4			5.7			36.1	60.4
Effective Green, g (s)	8.0	66.9		1.5	60.4			5.7			36.1	60.4
Actuated g/C Ratio	0.06	0.53		0.01	0.48			0.05			0.29	0.48
Clearance Time (s)	4.0	4.0		4.0	4.0			4.0			4.0	4.0
Vehicle Extension (s)	3.0	3.0		3.0	3.0			3.0			3.0	3.0
Lane Grp Cap (vph)	112	1876		21	1598			75			507	757
v/s Ratio Prot	c0.05	0.23		0.01	c0.41			c0.01			c0.25	
v/s Ratio Perm												0.05
v/c Ratio	0.79	0.44		0.52	0.85			0.14			0.88	0.10
Uniform Delay, d1	58.3	18.2		62.0	28.9			57.9			42.9	18.0
Progression Factor	1.00	1.00		1.00	1.00			1.00			1.00	1.00
Incremental Delay, d2	29.4	0.2		21.6	4.6			0.8			15.7	0.1
Delay (s)	87.7	18.3		83.6	33.5			58.7			58.6	18.1
Level of Service	F	B		F	C			E			E	B
Approach Delay (s)		25.0			33.9			58.7			52.9	
Approach LOS		C			C			E			D	
<b>Intersection Summary</b>												
HCM 2000 Control Delay			34.8									HCM 2000 Level of Service C
HCM 2000 Volume to Capacity ratio			0.82									
Actuated Cycle Length (s)			126.2							16.0		
Intersection Capacity Utilization			77.5%									ICU Level of Service D
Analysis Period (min)			15									
c Critical Lane Group												























HCM 6th Signalized Intersection Summary  
7: Driveway 1/Gridley Drive & Shiloh Road

GP 2040+Project Alternative B\_Mitigations  
Timing Plan: P.M. Peak

												
Movement	EBL	EBT	EBR	WBL	WBT	WBR	NBL	NBT	NBR	SBL	SBT	SBR
Lane Configurations												
Traffic Volume (veh/h)	25	385	76	0	401	0	71	0	0	0	0	21
Future Volume (veh/h)	25	385	76	0	401	0	71	0	0	0	0	21
Initial Q (Qb), veh	0	0	0	0	0	0	0	0	0	0	0	0
Ped-Bike Adj(A_pbT)	1.00		0.99	1.00		1.00	1.00		1.00	1.00		1.00
Parking Bus, Adj	1.00	1.00	1.00	1.00	1.00	1.00	1.00	1.00	1.00	1.00	1.00	1.00
Work Zone On Approach		No			No			No			No	
Adj Sat Flow, veh/h/ln	1870	1870	1870	1870	1870	1870	1870	1870	1870	1870	1870	1870
Adj Flow Rate, veh/h	27	410	81	0	581	0	71	0	0	0	0	36
Peak Hour Factor	0.94	0.94	0.94	0.69	0.69	0.69	1.00	1.00	1.00	0.58	0.58	0.58
Percent Heavy Veh, %	2	2	2	2	2	2	2	2	2	2	2	2
Cap, veh/h	127	695	650	0	777	0	586	544	0	0	0	461
Arrive On Green	0.42	0.42	0.42	0.00	0.42	0.00	0.29	0.00	0.00	0.00	0.00	0.29
Sat Flow, veh/h	39	1674	1564	0	1870	0	1372	1870	0	0	0	1585
Grp Volume(v), veh/h	437	0	81	0	581	0	71	0	0	0	0	36
Grp Sat Flow(s),veh/h/ln	1713	0	1564	0	1870	0	1372	1870	0	0	0	1585
Q Serve(g_s), s	0.3	0.0	1.1	0.0	9.1	0.0	1.4	0.0	0.0	0.0	0.0	0.6
Cycle Q Clear(g_c), s	9.3	0.0	1.1	0.0	9.1	0.0	1.9	0.0	0.0	0.0	0.0	0.6
Prop In Lane	0.06		1.00	0.00		0.00	1.00		0.00	0.00		1.00
Lane Grp Cap(c), veh/h	823	0	650	0	777	0	586	544	0	0	0	461
V/C Ratio(X)	0.53	0.00	0.12	0.00	0.75	0.00	0.12	0.00	0.00	0.00	0.00	0.08
Avail Cap(c_a), veh/h	1445	0	1210	0	1447	0	1117	1268	0	0	0	1074
HCM Platoon Ratio	1.00	1.00	1.00	1.00	1.00	1.00	1.00	1.00	1.00	1.00	1.00	1.00
Upstream Filter(I)	1.00	0.00	1.00	0.00	1.00	0.00	1.00	0.00	0.00	0.00	0.00	1.00
Uniform Delay (d), s/veh	7.7	0.0	6.2	0.0	8.5	0.0	9.5	0.0	0.0	0.0	0.0	8.8
Incr Delay (d2), s/veh	0.5	0.0	0.1	0.0	1.5	0.0	0.1	0.0	0.0	0.0	0.0	0.1
Initial Q Delay(d3), s/veh	0.0	0.0	0.0	0.0	0.0	0.0	0.0	0.0	0.0	0.0	0.0	0.0
%ile BackOfQ(50%),veh/ln	1.4	0.0	0.2	0.0	2.2	0.0	0.3	0.0	0.0	0.0	0.0	0.2
Unsig. Movement Delay, s/veh												
LnGrp Delay(d), s/veh	8.2	0.0	6.3	0.0	10.0	0.0	9.6	0.0	0.0	0.0	0.0	8.9
LnGrp LOS	A		A		A		A					A
Approach Vol, veh/h		518			581			71				36
Approach Delay, s/veh		7.9			10.0			9.6				8.9
Approach LOS		A			A			A				A
Timer - Assigned Phs		2		4		6		8				
Phs Duration (G+Y+Rc), s		14.7		19.7		14.7		19.7				
Change Period (Y+Rc), s		4.7		5.4		4.7		5.4				
Max Green Setting (Gmax), s		23.3		26.6		23.3		26.6				
Max Q Clear Time (g_c+I1), s		3.9		11.3		2.6		11.1				
Green Ext Time (p_c), s		0.1		2.6		0.1		3.2				
<b>Intersection Summary</b>												
HCM 6th Ctrl Delay, s/veh			9.0									
HCM 6th LOS			A									

























HCM 6th Signalized Intersection Summary  
8: Old Redwood Hwy & Driveway 2

GP 2040+Project Alternative B\_Mitigations  
Timing Plan: P.M. Peak

												
Movement	EBL	EBT	EBR	WBL	WBT	WBR	NBL	NBT	NBR	SBL	SBT	SBR
Lane Configurations												
Traffic Volume (veh/h)	4	0	0	41	0	66	0	1195	45	72	1152	0
Future Volume (veh/h)	4	0	0	41	0	66	0	1195	45	72	1152	0
Initial Q (Qb), veh	0	0	0	0	0	0	0	0	0	0	0	0
Ped-Bike Adj(A_pbT)	1.00		1.00	1.00		1.00	1.00		0.99	1.00		1.00
Parking Bus, Adj	1.00	1.00	1.00	1.00	1.00	1.00	1.00	1.00	1.00	1.00	1.00	1.00
Work Zone On Approach		No			No			No			No	
Adj Sat Flow, veh/h/ln	1870	1870	1870	1870	1870	1870	1870	1870	1870	1870	1870	1870
Adj Flow Rate, veh/h	11	0	0	41	0	66	0	1313	49	77	1226	0
Peak Hour Factor	0.38	0.38	0.38	1.00	1.00	1.00	0.91	0.91	0.91	0.94	0.94	0.94
Percent Heavy Veh, %	2	2	2	2	2	2	2	2	2	2	2	2
Cap, veh/h	149	0	0	227	0	153	0	1491	1248	200	1491	0
Arrive On Green	0.10	0.00	0.00	0.10	0.00	0.10	0.00	0.80	0.80	0.80	0.80	0.00
Sat Flow, veh/h	794	0	0	1418	0	1585	0	1870	1565	399	1870	0
Grp Volume(v), veh/h	11	0	0	41	0	66	0	1313	49	77	1226	0
Grp Sat Flow(s),veh/h/ln	794	0	0	1418	0	1585	0	1870	1565	399	1870	0
Q Serve(g_s), s	0.8	0.0	0.0	0.0	0.0	3.9	0.0	47.4	0.7	16.1	38.3	0.0
Cycle Q Clear(g_c), s	4.7	0.0	0.0	2.1	0.0	3.9	0.0	47.4	0.7	63.5	38.3	0.0
Prop In Lane	1.00		0.00	1.00		1.00	0.00		1.00	1.00		0.00
Lane Grp Cap(c), veh/h	149	0	0	227	0	153	0	1491	1248	200	1491	0
V/C Ratio(X)	0.07	0.00	0.00	0.18	0.00	0.43	0.00	0.88	0.04	0.38	0.82	0.00
Avail Cap(c_a), veh/h	262	0	0	347	0	287	0	1724	1442	250	1724	0
HCM Platoon Ratio	1.00	1.00	1.00	1.00	1.00	1.00	1.00	1.00	1.00	1.00	1.00	1.00
Upstream Filter(I)	1.00	0.00	0.00	1.00	0.00	1.00	0.00	1.00	1.00	1.00	1.00	0.00
Uniform Delay (d), s/veh	44.5	0.0	0.0	41.5	0.0	42.3	0.0	6.8	2.1	28.4	5.9	0.0
Incr Delay (d2), s/veh	0.2	0.0	0.0	0.4	0.0	1.9	0.0	5.1	0.0	1.2	2.9	0.0
Initial Q Delay(d3), s/veh	0.0	0.0	0.0	0.0	0.0	0.0	0.0	0.0	0.0	0.0	0.0	0.0
%ile BackOfQ(50%),veh/ln	0.3	0.0	0.0	0.9	0.0	1.6	0.0	11.1	0.1	1.5	8.5	0.0
Unsig. Movement Delay, s/veh												
LnGrp Delay(d), s/veh	44.7	0.0	0.0	41.8	0.0	44.2	0.0	11.9	2.1	29.6	8.9	0.0
LnGrp LOS	D			D		D		B	A	C	A	
Approach Vol, veh/h		11			107			1362			1303	
Approach Delay, s/veh		44.7			43.3			11.6			10.1	
Approach LOS		D			D			B			B	
Timer - Assigned Phs		2		4		6		8				
Phs Duration (G+Y+Rc), s		85.0		14.3		85.0		14.3				
Change Period (Y+Rc), s		5.8		4.7		5.8		4.7				
Max Green Setting (Gmax), s		91.5		18.0		91.5		18.0				
Max Q Clear Time (g_c+I1), s		49.4		6.7		65.5		5.9				
Green Ext Time (p_c), s		18.1		0.0		13.7		0.3				
<b>Intersection Summary</b>												
HCM 6th Ctrl Delay, s/veh				12.2								
HCM 6th LOS				B								

HCM 6th Signalized Intersection Summary  
 1: Old Redwood Hwy & Shiloh Road

GP 2040+Project Alternative B\_Mitigations  
 Timing Plan: Saturday Midday Peak

												
Movement	EBL	EBT	EBR	WBL	WBT	WBR	NBL	NBT	NBR	SBL	SBT	SBR
Lane Configurations												
Traffic Volume (veh/h)	182	475	301	31	510	76	314	351	35	79	284	266
Future Volume (veh/h)	182	475	301	31	510	76	314	351	35	79	284	266
Initial Q (Qb), veh	0	0	0	0	0	0	0	0	0	0	0	0
Ped-Bike Adj(A_pbT)	1.00		0.97	1.00		1.00	1.00		0.98	1.00		0.98
Parking Bus, Adj	1.00	1.00	1.00	1.00	1.00	1.00	1.00	1.00	1.00	1.00	1.00	1.00
Work Zone On Approach		No			No			No			No	
Adj Sat Flow, veh/h/ln	1870	1870	1870	1870	1870	1870	1870	1870	1870	1870	1870	1870
Adj Flow Rate, veh/h	204	534	338	36	593	88	338	377	38	87	312	292
Peak Hour Factor	0.89	0.89	0.89	0.86	0.86	0.86	0.93	0.93	0.93	0.91	0.91	0.91
Percent Heavy Veh, %	2	2	2	2	2	2	2	2	2	2	2	2
Cap, veh/h	258	1150	499	121	878	391	446	1047	457	134	855	375
Arrive On Green	0.14	0.32	0.32	0.07	0.25	0.25	0.13	0.29	0.29	0.08	0.24	0.24
Sat Flow, veh/h	1781	3554	1542	1781	3554	1585	3456	3554	1551	1781	3554	1559
Grp Volume(v), veh/h	204	534	338	36	593	88	338	377	38	87	312	292
Grp Sat Flow(s),veh/h/ln	1781	1777	1542	1781	1777	1585	1728	1777	1551	1781	1777	1559
Q Serve(g_s), s	8.1	8.8	13.9	1.4	11.1	3.2	6.9	6.1	1.3	3.5	5.4	12.8
Cycle Q Clear(g_c), s	8.1	8.8	13.9	1.4	11.1	3.2	6.9	6.1	1.3	3.5	5.4	12.8
Prop In Lane	1.00		1.00	1.00		1.00	1.00		1.00	1.00		1.00
Lane Grp Cap(c), veh/h	258	1150	499	121	878	391	446	1047	457	134	855	375
V/C Ratio(X)	0.79	0.46	0.68	0.30	0.68	0.22	0.76	0.36	0.08	0.65	0.36	0.78
Avail Cap(c_a), veh/h	728	1477	641	923	1865	832	659	2034	888	170	1695	744
HCM Platoon Ratio	1.00	1.00	1.00	1.00	1.00	1.00	1.00	1.00	1.00	1.00	1.00	1.00
Upstream Filter(I)	1.00	1.00	1.00	1.00	1.00	1.00	1.00	1.00	1.00	1.00	1.00	1.00
Uniform Delay (d), s/veh	30.3	19.7	21.5	32.5	25.0	22.0	30.8	20.4	18.7	33.0	23.2	26.0
Incr Delay (d2), s/veh	5.4	0.3	1.9	1.3	0.9	0.3	2.9	0.2	0.1	5.7	0.3	3.5
Initial Q Delay(d3),s/veh	0.0	0.0	0.0	0.0	0.0	0.0	0.0	0.0	0.0	0.0	0.0	0.0
%ile BackOfQ(50%),veh/ln	3.6	3.3	4.7	0.6	4.4	1.1	2.8	2.3	0.4	1.6	2.1	4.6
Unsig. Movement Delay, s/veh												
LnGrp Delay(d),s/veh	35.7	20.0	23.4	33.9	25.9	22.3	33.8	20.6	18.8	38.7	23.4	29.5
LnGrp LOS	D	C	C	C	C	C	C	C	B	D	C	C
Approach Vol, veh/h		1076			717			753			691	
Approach Delay, s/veh		24.1			25.8			26.4			27.9	
Approach LOS		C			C			C			C	
Timer - Assigned Phs	1	2	3	4	5	6	7	8				
Phs Duration (G+Y+Rc), s	9.5	28.2	13.5	22.2	15.1	22.6	9.5	26.1				
Change Period (Y+Rc), s	4.5	4.5	4.0	4.5	4.5	4.5	4.0	4.5				
Max Green Setting (Gmax), s	38.0	30.5	14.0	35.0	30.0	38.5	7.0	42.0				
Max Q Clear Time (g_c+I1), s	3.4	15.9	8.9	14.8	10.1	13.1	5.5	8.1				
Green Ext Time (p_c), s	0.1	4.0	0.5	2.8	0.5	4.2	0.0	2.5				
<b>Intersection Summary</b>												
HCM 6th Ctrl Delay			25.8									
HCM 6th LOS			C									

HCM 6th Signalized Intersection Summary  
2: Shiloh Road & Hembree Ln

GP 2040+Project Alternative B\_Mitigations  
Timing Plan: Saturday Midday Peak



Movement	EBL	EBT	EBR	WBL	WBT	WBR	NBL	NBT	NBR	SBL	SBT	SBR
Lane Configurations	↖↗	↕		↖↗	↕		↖	↗		↖	↕	↗↖
Traffic Volume (veh/h)	918	827	69	110	796	235	110	21	128	236	11	856
Future Volume (veh/h)	918	827	69	110	796	235	110	21	128	236	11	856
Initial Q (Qb), veh	0	0	0	0	0	0	0	0	0	0	0	0
Ped-Bike Adj(A_pbT)	1.00		1.00	1.00		1.00	1.00		1.00	1.00		1.00
Parking Bus, Adj	1.00	1.00	1.00	1.00	1.00	1.00	1.00	1.00	1.00	1.00	1.00	1.00
Work Zone On Approach		No			No			No			No	
Adj Sat Flow, veh/h/ln	1870	1870	1870	1870	1870	1870	1870	1870	1870	1870	1870	1870
Adj Flow Rate, veh/h	918	827	69	110	796	235	110	21	128	236	11	856
Peak Hour Factor	1.00	1.00	1.00	1.00	1.00	1.00	1.00	1.00	1.00	1.00	1.00	1.00
Percent Heavy Veh, %	2	2	2	2	2	2	2	2	2	2	2	2
Cap, veh/h	1001	1849	154	137	931	275	145	13	78	268	234	1157
Arrive On Green	0.29	0.56	0.56	0.08	0.34	0.34	0.08	0.06	0.06	0.15	0.13	0.13
Sat Flow, veh/h	3456	3320	277	1781	2704	798	1781	228	1392	1781	1870	2790
Grp Volume(v), veh/h	918	443	453	110	523	508	110	0	149	236	11	856
Grp Sat Flow(s),veh/h/ln	1728	1777	1820	1781	1777	1726	1781	0	1620	1781	1870	1395
Q Serve(g_s), s	25.8	14.7	14.7	6.1	27.4	27.4	6.1	0.0	5.6	13.0	0.5	12.5
Cycle Q Clear(g_c), s	25.8	14.7	14.7	6.1	27.4	27.4	6.1	0.0	5.6	13.0	0.5	12.5
Prop In Lane	1.00		0.15	1.00		0.46	1.00		0.86	1.00		1.00
Lane Grp Cap(c), veh/h	1001	990	1014	137	612	594	145	0	91	268	234	1157
V/C Ratio(X)	0.92	0.45	0.45	0.80	0.85	0.86	0.76	0.00	1.65	0.88	0.05	0.74
Avail Cap(c_a), veh/h	1069	1133	1161	146	729	708	238	0	91	290	234	1157
HCM Platoon Ratio	1.00	1.00	1.00	1.00	1.00	1.00	1.00	1.00	1.00	1.00	1.00	1.00
Upstream Filter(I)	1.00	1.00	1.00	1.00	1.00	1.00	1.00	0.00	1.00	1.00	1.00	1.00
Uniform Delay (d), s/veh	34.4	13.1	13.1	45.5	30.5	30.5	45.1	0.0	47.3	41.7	38.6	24.8
Incr Delay (d2), s/veh	11.8	0.3	0.3	25.5	8.5	8.8	7.8	0.0	334.7	24.1	0.1	2.6
Initial Q Delay(d3),s/veh	0.0	0.0	0.0	0.0	0.0	0.0	0.0	0.0	0.0	0.0	0.0	0.0
%ile BackOfQ(50%),veh/ln	1.9	5.4	5.5	3.6	12.5	12.2	3.0	0.0	10.7	7.4	0.2	8.7
Unsig. Movement Delay, s/veh												
LnGrp Delay(d),s/veh	46.2	13.4	13.4	71.0	39.1	39.3	52.9	0.0	382.0	65.8	38.7	27.3
LnGrp LOS	D	B	B	E	D	D	D	A	F	E	D	C
Approach Vol, veh/h		1814			1141			259			1103	
Approach Delay, s/veh		30.0			42.3			242.2			35.7	
Approach LOS		C			D			F			D	
Timer - Assigned Phs	1	2	3	4	5	6	7	8				
Phs Duration (G+Y+Rc), s	11.7	59.8	12.2	16.5	33.0	38.5	19.1	9.6				
Change Period (Y+Rc), s	4.0	4.0	4.0	4.0	4.0	4.0	4.0	4.0				
Max Green Setting (Gmax), s	63.9	63.9	13.4	8.5	31.0	41.1	16.3	5.6				
Max Q Clear Time (g_c+1), s	16.7	16.7	8.1	14.5	27.8	29.4	15.0	7.6				
Green Ext Time (p_c), s	0.0	6.3	0.1	0.0	1.3	4.9	0.1	0.0				

Intersection Summary

HCM 6th Ctrl Delay	47.4
HCM 6th LOS	D

HCM 6th Signalized Intersection Summary  
 3: US 101 NB Off-Ramp & Shiloh Road

GP 2040+Project Alternative B\_Mitigations  
 Timing Plan: Saturday Midday Peak

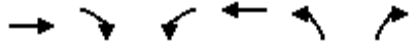

Movement	EBT	EBR	WBL	WBT	NBL	NBR
Lane Configurations	↑↑			↑↑	↵	↵↵
Traffic Volume (veh/h)	705	0	0	1233	520	1038
Future Volume (veh/h)	705	0	0	1233	520	1038
Initial Q (Qb), veh	0	0	0	0	0	0
Ped-Bike Adj(A_pbT)		1.00	1.00		1.00	1.00
Parking Bus, Adj	1.00	1.00	1.00	1.00	1.00	1.00
Work Zone On Approach	No			No	No	
Adj Sat Flow, veh/h/ln	1870	0	0	1870	1870	1870
Adj Flow Rate, veh/h	775	0	0	1385	547	1093
Peak Hour Factor	0.91	0.91	0.89	0.89	0.95	0.95
Percent Heavy Veh, %	2	0	0	2	2	2
Cap, veh/h	1585	0	0	1585	714	1118
Arrive On Green	0.45	0.00	0.00	0.45	0.40	0.40
Sat Flow, veh/h	3741	0	0	3741	1781	2790
Grp Volume(v), veh/h	775	0	0	1385	547	1093
Grp Sat Flow(s),veh/h/ln	1777	0	0	1777	1781	1395
Q Serve(g_s), s	9.1	0.0	0.0	20.8	15.6	22.6
Cycle Q Clear(g_c), s	9.1	0.0	0.0	20.8	15.6	22.6
Prop In Lane		0.00	0.00		1.00	1.00
Lane Grp Cap(c), veh/h	1585	0	0	1585	714	1118
V/C Ratio(X)	0.49	0.00	0.00	0.87	0.77	0.98
Avail Cap(c_a), veh/h	1666	0	0	1666	714	1118
HCM Platoon Ratio	1.00	1.00	1.00	1.00	1.00	1.00
Upstream Filter(I)	1.00	0.00	0.00	1.00	1.00	1.00
Uniform Delay (d), s/veh	11.5	0.0	0.0	14.8	15.2	17.3
Incr Delay (d2), s/veh	0.2	0.0	0.0	5.3	5.0	21.7
Initial Q Delay(d3),s/veh	0.0	0.0	0.0	0.0	0.0	0.0
%ile BackOfQ(50%),veh/ln	2.9	0.0	0.0	7.6	6.4	9.5
Unsig. Movement Delay, s/veh						
LnGrp Delay(d),s/veh	11.7	0.0	0.0	20.1	20.2	39.0
LnGrp LOS	B	A	A	C	C	D
Approach Vol, veh/h	775			1385	1640	
Approach Delay, s/veh	11.7			20.1	32.7	
Approach LOS	B			C	C	
Timer - Assigned Phs		2			6	8
Phs Duration (G+Y+Rc), s		30.7			30.7	28.0
Change Period (Y+Rc), s		4.5			4.5	4.5
Max Green Setting (Gmax), s		27.5			27.5	23.5
Max Q Clear Time (g_c+I1), s		11.1			22.8	24.6
Green Ext Time (p_c), s		4.6			3.4	0.0
<b>Intersection Summary</b>						
HCM 6th Ctrl Delay			23.8			
HCM 6th LOS			C			

Intersection						
Int Delay, s/veh	2.9					
Movement	EBT	EBR	WBL	WBT	NBL	NBR
Lane Configurations	↑↑		↘	↑↑	↘	↘
Traffic Vol, veh/h	823	30	120	910	24	115
Future Vol, veh/h	823	30	120	910	24	115
Conflicting Peds, #/hr	0	0	0	0	1	0
Sign Control	Free	Free	Free	Free	Stop	Stop
RT Channelized	-	None	-	None	-	None
Storage Length	-	-	68	-	0	0
Veh in Median Storage, #	0	-	-	0	0	-
Grade, %	0	-	-	0	0	-
Peak Hour Factor	92	92	87	87	78	78
Heavy Vehicles, %	2	2	2	2	2	2
Mvmt Flow	895	33	138	1046	31	147



















Major/Minor	Major1	Major2	Minor1		
Conflicting Flow All	0	0	928	0	1712
Stage 1	-	-	-	-	912
Stage 2	-	-	-	-	800
Critical Hdwy	-	-	4.14	-	6.84
Critical Hdwy Stg 1	-	-	-	-	5.84
Critical Hdwy Stg 2	-	-	-	-	5.84
Follow-up Hdwy	-	-	2.22	-	3.52
Pot Cap-1 Maneuver	-	-	733	-	81
Stage 1	-	-	-	-	352
Stage 2	-	-	-	-	403
Platoon blocked, %	-	-	-	-	-
Mov Cap-1 Maneuver	-	-	733	-	66
Mov Cap-2 Maneuver	-	-	-	-	66
Stage 1	-	-	-	-	352
Stage 2	-	-	-	-	327

Approach	EB	WB	NB
HCM Control Delay, s	0	1.3	28.9
HCM LOS			D

Minor Lane/Major Mvmt	NBLn1	NBLn2	EBT	EBR	WBL	WBT
Capacity (veh/h)	66	545	-	-	733	-
HCM Lane V/C Ratio	0.466	0.271	-	-	0.188	-
HCM Control Delay (s)	100.3	14	-	-	11	-
HCM Lane LOS	F	B	-	-	B	-
HCM 95th %tile Q(veh)	1.8	1.1	-	-	0.7	-





















HCM 6th Signalized Intersection Summary  
7: Driveway 1/Gridley Drive & Shiloh Road

GP 2040+Project Alternative B\_Mitigations  
Timing Plan: Saturday Midday Peak

												
Movement	EBL	EBT	EBR	WBL	WBT	WBR	NBL	NBT	NBR	SBL	SBT	SBR
Lane Configurations												
Traffic Volume (veh/h)	30	473	103	0	482	0	113	0	0	0	0	27
Future Volume (veh/h)	30	473	103	0	482	0	113	0	0	0	0	27
Initial Q (Qb), veh	0	0	0	0	0	0	0	0	0	0	0	0
Ped-Bike Adj(A_pbT)	1.00		0.99	1.00		1.00	1.00		1.00	1.00		1.00
Parking Bus, Adj	1.00	1.00	1.00	1.00	1.00	1.00	1.00	1.00	1.00	1.00	1.00	1.00
Work Zone On Approach		No			No			No			No	
Adj Sat Flow, veh/h/ln	1870	1870	1870	1870	1870	1870	1870	1870	1870	1870	1870	1870
Adj Flow Rate, veh/h	32	509	111	0	548	0	113	0	0	0	0	48
Peak Hour Factor	0.93	0.93	0.93	0.88	0.88	0.88	1.00	1.00	1.00	0.56	0.56	0.56
Percent Heavy Veh, %	2	2	2	2	2	2	2	2	2	2	2	2
Cap, veh/h	129	713	651	0	779	0	573	543	0	0	0	460
Arrive On Green	0.42	0.42	0.42	0.00	0.42	0.00	0.29	0.00	0.00	0.00	0.00	0.29
Sat Flow, veh/h	43	1712	1564	0	1870	0	1357	1870	0	0	0	1585
Grp Volume(v), veh/h	541	0	111	0	548	0	113	0	0	0	0	48
Grp Sat Flow(s),veh/h/ln	1755	0	1564	0	1870	0	1357	1870	0	0	0	1585
Q Serve(g_s), s	0.6	0.0	1.5	0.0	8.3	0.0	2.3	0.0	0.0	0.0	0.0	0.8
Cycle Q Clear(g_c), s	8.9	0.0	1.5	0.0	8.3	0.0	3.1	0.0	0.0	0.0	0.0	0.8
Prop In Lane	0.06		1.00	0.00		0.00	1.00		0.00	0.00		1.00
Lane Grp Cap(c), veh/h	842	0	651	0	779	0	573	543	0	0	0	460
V/C Ratio(X)	0.64	0.00	0.17	0.00	0.70	0.00	0.20	0.00	0.00	0.00	0.00	0.10
Avail Cap(c_a), veh/h	1464	0	1208	0	1444	0	1097	1265	0	0	0	1072
HCM Platoon Ratio	1.00	1.00	1.00	1.00	1.00	1.00	1.00	1.00	1.00	1.00	1.00	1.00
Upstream Filter(I)	1.00	0.00	1.00	0.00	1.00	0.00	1.00	0.00	0.00	0.00	0.00	1.00
Uniform Delay (d), s/veh	8.3	0.0	6.3	0.0	8.3	0.0	10.1	0.0	0.0	0.0	0.0	8.9
Incr Delay (d2), s/veh	0.8	0.0	0.1	0.0	1.2	0.0	0.2	0.0	0.0	0.0	0.0	0.1
Initial Q Delay(d3), s/veh	0.0	0.0	0.0	0.0	0.0	0.0	0.0	0.0	0.0	0.0	0.0	0.0
%ile BackOfQ(50%),veh/ln	1.9	0.0	0.3	0.0	2.0	0.0	0.5	0.0	0.0	0.0	0.0	0.2
Unsig. Movement Delay, s/veh												
LnGrp Delay(d), s/veh	9.1	0.0	6.4	0.0	9.5	0.0	10.2	0.0	0.0	0.0	0.0	9.0
LnGrp LOS	A		A		A		B					A
Approach Vol, veh/h		652			548			113				48
Approach Delay, s/veh		8.6			9.5			10.2				9.0
Approach LOS		A			A			B				A
Timer - Assigned Phs		2		4		6		8				
Phs Duration (G+Y+Rc), s		14.7		19.7		14.7		19.7				
Change Period (Y+Rc), s		4.7		5.4		4.7		5.4				
Max Green Setting (Gmax), s		23.3		26.6		23.3		26.6				
Max Q Clear Time (g_c+I1), s		5.1		10.9		2.8		10.3				
Green Ext Time (p_c), s		0.3		3.4		0.2		3.0				
<b>Intersection Summary</b>												
HCM 6th Ctrl Delay, s/veh			9.1									
HCM 6th LOS			A									

HCM 6th Signalized Intersection Summary  
8: Old Redwood Hwy & Driveway 2

GP 2040+Project Alternative B\_Mitigations  
Timing Plan: Saturday Midday Peak

												
Movement	EBL	EBT	EBR	WBL	WBT	WBR	NBL	NBT	NBR	SBL	SBT	SBR
Lane Configurations												
Traffic Volume (veh/h)	1	0	3	67	0	106	1	595	61	97	505	6
Future Volume (veh/h)	1	0	3	67	0	106	1	595	61	97	505	6
Initial Q (Qb), veh	0	0	0	0	0	0	0	0	0	0	0	0
Ped-Bike Adj(A_pbT)	1.00		1.00	1.00		1.00	1.00		0.98	1.00		0.97
Parking Bus, Adj	1.00	1.00	1.00	1.00	1.00	1.00	1.00	1.00	1.00	1.00	1.00	1.00
Work Zone On Approach		No			No			No			No	
Adj Sat Flow, veh/h/ln	1870	1870	1870	1870	1870	1870	1870	1870	1870	1870	1870	1870
Adj Flow Rate, veh/h	3	0	8	67	0	106	1	633	65	104	543	6
Peak Hour Factor	0.38	0.38	0.38	1.00	1.00	1.00	0.94	0.94	0.94	0.93	0.93	0.93
Percent Heavy Veh, %	2	2	2	2	2	2	2	2	2	2	2	2
Cap, veh/h	165	46	252	497	0	350	92	955	797	378	943	10
Arrive On Green	0.22	0.00	0.22	0.22	0.00	0.22	0.51	0.51	0.51	0.51	0.51	0.51
Sat Flow, veh/h	219	208	1139	1407	0	1585	0	1869	1560	747	1846	20
Grp Volume(v), veh/h	11	0	0	67	0	106	634	0	65	104	0	549
Grp Sat Flow(s),veh/h/ln	1566	0	0	1407	0	1585	1870	0	1560	747	0	1866
Q Serve(g_s), s	0.0	0.0	0.0	1.3	0.0	2.2	0.0	0.0	0.8	4.7	0.0	8.0
Cycle Q Clear(g_c), s	0.2	0.0	0.0	1.5	0.0	2.2	9.8	0.0	0.8	14.5	0.0	8.0
Prop In Lane	0.27		0.73	1.00		1.00	0.00		1.00	1.00		0.01
Lane Grp Cap(c), veh/h	463	0	0	497	0	350	1047	0	797	378	0	953
V/C Ratio(X)	0.02	0.00	0.00	0.13	0.00	0.30	0.61	0.00	0.08	0.27	0.00	0.58
Avail Cap(c_a), veh/h	819	0	0	833	0	729	1596	0	1256	598	0	1501
HCM Platoon Ratio	1.00	1.00	1.00	1.00	1.00	1.00	1.00	1.00	1.00	1.00	1.00	1.00
Upstream Filter(I)	1.00	0.00	0.00	1.00	0.00	1.00	1.00	0.00	1.00	1.00	0.00	1.00
Uniform Delay (d), s/veh	12.0	0.0	0.0	12.4	0.0	12.7	7.1	0.0	4.9	12.4	0.0	6.6
Incr Delay (d2), s/veh	0.0	0.0	0.0	0.1	0.0	0.5	0.6	0.0	0.0	0.4	0.0	0.6
Initial Q Delay(d3), s/veh	0.0	0.0	0.0	0.0	0.0	0.0	0.0	0.0	0.0	0.0	0.0	0.0
%ile BackOfQ(50%),veh/ln	0.1	0.0	0.0	0.4	0.0	0.7	1.8	0.0	0.1	0.6	0.0	1.5
Unsig. Movement Delay, s/veh												
LnGrp Delay(d), s/veh	12.0	0.0	0.0	12.6	0.0	13.2	7.7	0.0	4.9	12.8	0.0	7.2
LnGrp LOS	B			B		B	A		A	B		A
Approach Vol, veh/h		11			173			699			653	
Approach Delay, s/veh		12.0			13.0			7.4			8.1	
Approach LOS		B			B			A			A	
Timer - Assigned Phs		2		4		6		8				
Phs Duration (G+Y+Rc), s		25.8		13.3		25.8		13.3				
Change Period (Y+Rc), s		5.8		4.7		5.8		4.7				
Max Green Setting (Gmax), s		31.5		18.0		31.5		18.0				
Max Q Clear Time (g_c+I1), s		11.8		2.2		16.5		4.2				
Green Ext Time (p_c), s		4.0		0.0		3.5		0.6				
<b>Intersection Summary</b>												
HCM 6th Ctrl Delay, s/veh				8.4								
HCM 6th LOS				A								



HCM 6th Signalized Intersection Summary

GP 2040+Project Alternative B\_Mitigations

12: US 101 SB On Ramp/US 101 SB Off Ramp & Old Redwood Highway Timing Plan: Saturday Midday Peak



Movement	EBL	EBT	EBR	WBL	WBT	WBR	NBL	NBT	NBR	SBL	SBT	SBR
Lane Configurations		↑↑	↑	↑	↑↑					↑	↑	
Traffic Volume (veh/h)	0	713	543	632	1060	0	0	0	0	257	1	112
Future Volume (veh/h)	0	713	543	632	1060	0	0	0	0	257	1	112
Initial Q (Qb), veh	0	0	0	0	0	0				0	0	0
Ped-Bike Adj(A_pbT)	1.00		0.98	1.00		1.00				1.00		1.00
Parking Bus, Adj	1.00	1.00	1.00	1.00	1.00	1.00				1.00	1.00	1.00
Work Zone On Approach		No			No						No	
Adj Sat Flow, veh/h/ln	0	1870	1870	1870	1870	0				1870	1870	1870
Adj Flow Rate, veh/h	0	713	543	632	1060	0				185	102	0
Peak Hour Factor	1.00	1.00	1.00	1.00	1.00	1.00				1.00	1.00	1.00
Percent Heavy Veh, %	0	2	2	2	2	0				2	2	2
Cap, veh/h	0	1233	539	668	2746	0				224	235	
Arrive On Green	0.00	0.35	0.35	0.37	0.77	0.00				0.13	0.13	0.00
Sat Flow, veh/h	0	3647	1553	1781	3647	0				1781	1870	0
Grp Volume(v), veh/h	0	713	543	632	1060	0				185	102	0
Grp Sat Flow(s),veh/h/ln	0	1777	1553	1781	1777	0				1781	1870	0
Q Serve(g_s), s	0.0	14.5	30.8	30.5	8.6	0.0				9.0	4.5	0.0
Cycle Q Clear(g_c), s	0.0	14.5	30.8	30.5	8.6	0.0				9.0	4.5	0.0
Prop In Lane	0.00		1.00	1.00		0.00				1.00		0.00
Lane Grp Cap(c), veh/h	0	1233	539	668	2746	0				224	235	
V/C Ratio(X)	0.00	0.58	1.01	0.95	0.39	0.00				0.83	0.43	
Avail Cap(c_a), veh/h	0	1233	539	713	2746	0				251	264	
HCM Platoon Ratio	1.00	1.00	1.00	1.00	1.00	1.00				1.00	1.00	1.00
Upstream Filter(I)	0.00	1.00	1.00	1.00	1.00	0.00				1.00	1.00	0.00
Uniform Delay (d), s/veh	0.0	23.6	28.9	26.8	3.3	0.0				37.8	35.8	0.0
Incr Delay (d2), s/veh	0.0	2.0	40.6	20.9	0.4	0.0				18.2	1.3	0.0
Initial Q Delay(d3),s/veh	0.0	0.0	0.0	0.0	0.0	0.0				0.0	0.0	0.0
%ile BackOfQ(50%),veh/ln	0.0	6.1	16.8	15.9	2.0	0.0				5.0	2.1	0.0
Unsig. Movement Delay, s/veh												
LnGrp Delay(d),s/veh	0.0	25.6	69.5	47.8	3.7	0.0				56.0	37.1	0.0
LnGrp LOS		A	C	F	D	A				E	D	
Approach Vol, veh/h		1256			1692					287		
Approach Delay, s/veh		44.6			20.1					49.3		
Approach LOS		D			C					D		
Timer - Assigned Phs		2			5	6		8				
Phs Duration (G+Y+Rc), s		73.0			37.7	35.3		15.6				
Change Period (Y+Rc), s		4.5			4.5	4.5		4.5				
Max Green Setting (Gmax), s		68.5			35.5	28.5		12.5				
Max Q Clear Time (g_c+1), s		10.6			32.5	32.8		11.0				
Green Ext Time (p_c), s		9.8			0.8	0.0		0.2				

Intersection Summary

HCM 6th Ctrl Delay	32.2
HCM 6th LOS	C

Notes

- User approved volume balancing among the lanes for turning movement.
- User approved ignoring U-Turning movement.
- Unsignalized Delay for [SBR] is excluded from calculations of the approach delay and intersection delay.

Queues  
1: Old Redwood Hwy & Shiloh Road



Lane Group	EBL	EBT	EBR	WBL	WBT	WBR	NBL	NBT	NBR	SBL	SBT	SBR
Lane Group Flow (vph)	313	310	440	40	242	29	364	312	18	53	479	398
v/c Ratio	0.70	0.24	0.51	0.25	0.49	0.09	0.60	0.25	0.02	0.36	0.58	0.59
Control Delay (s/veh)	39.4	21.9	4.9	44.3	39.5	0.5	40.1	22.7	0.1	49.1	33.2	7.3
Queue Delay	0.0	0.0	0.0	0.0	0.0	0.0	0.0	0.0	0.0	0.0	0.0	0.0
Total Delay (s/veh)	39.4	21.9	4.9	44.3	39.5	0.5	40.1	22.7	0.1	49.1	33.2	7.3
Queue Length 50th (ft)	151	65	0	20	63	0	92	64	0	27	120	0
Queue Length 95th (ft)	278	114	68	59	119	0	#182	116	0	76	196	75
Internal Link Dist (ft)		1709			528			668			695	
Turn Bay Length (ft)	425		200	200		50	430		98	190		160
Base Capacity (vph)	638	1346	875	809	1626	784	611	1805	862	157	1490	888
Starvation Cap Reductn	0	0	0	0	0	0	0	0	0	0	0	0
Spillback Cap Reductn	0	0	0	0	0	0	0	0	0	0	0	0
Storage Cap Reductn	0	0	0	0	0	0	0	0	0	0	0	0
Reduced v/c Ratio	0.49	0.23	0.50	0.05	0.15	0.04	0.60	0.17	0.02	0.34	0.32	0.45

Intersection Summary

# 95th percentile volume exceeds capacity, queue may be longer.  
Queue shown is maximum after two cycles.

Queues

2: Shiloh Road & Hembree Ln



Lane Group	EBL	EBT	WBL	WBT	NBL	NBT	SBL	SBT	SBR
Lane Group Flow (vph)	353	1146	49	985	49	27	137	18	606
v/c Ratio	0.58	0.54	0.24	0.68	0.19	0.14	0.54	0.07	0.51
Control Delay (s/veh)	30.5	9.6	32.3	16.1	28.2	22.5	38.5	29.9	12.9
Queue Delay	0.0	0.0	0.0	0.0	0.0	0.0	0.0	0.0	0.0
Total Delay (s/veh)	30.5	9.6	32.3	16.1	28.2	22.5	38.5	29.9	12.9
Queue Length 50th (ft)	49	60	13	117	13	3	38	5	33
Queue Length 95th (ft)	#147	234	56	220	56	30	#155	28	135
Internal Link Dist (ft)		222		1709		136		492	
Turn Bay Length (ft)			100				350		
Base Capacity (vph)	626	2782	209	2585	266	184	258	255	1186
Starvation Cap Reductn	0	0	0	0	0	0	0	0	0
Spillback Cap Reductn	0	0	0	0	0	0	0	0	0
Storage Cap Reductn	0	0	0	0	0	0	0	0	0
Reduced v/c Ratio	0.56	0.41	0.23	0.38	0.18	0.15	0.53	0.07	0.51

Intersection Summary

# 95th percentile volume exceeds capacity, queue may be longer.  
 Queue shown is maximum after two cycles.

Queues  
3: US 101 NB Off-Ramp & Shiloh Road



Lane Group	EBT	WBT	NBL	NBR
Lane Group Flow (vph)	803	1226	1070	792
v/c Ratio	0.67	1.02	1.07	0.49
Control Delay (s/veh)	26.0	61.0	71.2	10.7
Queue Delay	0.0	0.0	0.0	0.0
Total Delay (s/veh)	26.0	61.0	71.2	10.7
Queue Length 50th (ft)	178	~349	~604	111
Queue Length 95th (ft)	241	#474	#623	122
Internal Link Dist (ft)	106	291	689	
Turn Bay Length (ft)				340
Base Capacity (vph)	1194	1194	995	1601
Starvation Cap Reductn	0	0	0	0
Spillback Cap Reductn	0	0	0	0
Storage Cap Reductn	0	0	0	0
Reduced v/c Ratio	0.67	1.03	1.08	0.49

Intersection Summary

- ~ Volume exceeds capacity, queue is theoretically infinite.  
Queue shown is maximum after two cycles.
- # 95th percentile volume exceeds capacity, queue may be longer.  
Queue shown is maximum after two cycles.

Queues  
6: Conde Lane & Shiloh Road

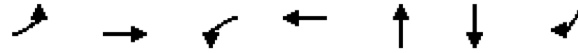

Lane Group	EBL	EBT	WBL	WBT	NBT	SBT	SBR
Lane Group Flow (vph)	58	566	9	1356	22	422	31
v/c Ratio	0.43	0.28	0.06	0.79	0.12	0.81	0.03
Control Delay (s/veh)	60.7	14.1	51.2	27.9	28.1	50.3	17.2
Queue Delay	0.0	0.0	0.0	0.0	0.0	0.0	0.0
Total Delay (s/veh)	60.7	14.1	51.2	27.9	28.1	50.3	17.2
Queue Length 50th (ft)	37	81	6	358	4	254	10
Queue Length 95th (ft)	87	190	23	521	15	#455	30
Internal Link Dist (ft)		735		1001	338	442	
Turn Bay Length (ft)	90		127				65
Base Capacity (vph)	134	1984	134	1700	533	520	782
Starvation Cap Reductn	0	0	0	0	0	0	0
Spillback Cap Reductn	0	0	0	0	0	0	0
Storage Cap Reductn	0	0	0	0	0	0	0
Reduced v/c Ratio	0.43	0.29	0.07	0.80	0.04	0.81	0.04

Intersection Summary

# 95th percentile volume exceeds capacity, queue may be longer.  
Queue shown is maximum after two cycles.

Queues

12: US 101 SB On Ramp/US 101 SB Off Ramp & Old Redwood Highway



Lane Group	EBT	EBR	WBL	WBT	SBL	SBT
Lane Group Flow (vph)	699	814	559	742	166	163
v/c Ratio	0.48	0.95	0.84	0.25	1.09	0.60
Control Delay (s/veh)	26.7	40.6	43.3	2.4	147.1	21.0
Queue Delay	0.0	0.0	0.0	0.0	0.0	0.0
Total Delay (s/veh)	26.7	40.6	43.3	2.4	147.1	21.0
Queue Length 50th (ft)	189	355	354	47	~138	13
Queue Length 95th (ft)	280	#697	434	61	#282	84
Internal Link Dist (ft)	343			451		751
Turn Bay Length (ft)			250		420	
Base Capacity (vph)	1449	853	817	2901	152	269
Starvation Cap Reductn	0	0	0	0	0	0
Spillback Cap Reductn	0	0	0	0	0	0
Storage Cap Reductn	0	0	0	0	0	0
Reduced v/c Ratio	0.48	0.95	0.68	0.26	1.09	0.61

Intersection Summary













~ Volume exceeds capacity, queue is theoretically infinite.

Queue shown is maximum after two cycles.

# 95th percentile volume exceeds capacity, queue may be longer.

Queue shown is maximum after two cycles.

Queues  
1: Old Redwood Hwy & Shiloh Road

												
Lane Group	EBL	EBT	EBR	WBL	WBT	WBR	NBL	NBT	NBR	SBL	SBT	SBR
Lane Group Flow (vph)	317	398	635	44	393	64	656	565	44	79	545	265
v/c Ratio	0.77	0.32	0.67	0.32	0.66	0.18	0.87	0.43	0.06	0.47	0.69	0.50
Control Delay (s/veh)	54.4	28.6	7.4	58.5	49.4	3.9	56.5	29.5	0.2	60.3	44.8	11.8
Queue Delay	0.0	0.0	0.0	0.0	0.0	0.0	0.0	0.0	0.0	0.0	0.0	0.0
Total Delay (s/veh)	54.4	28.6	7.4	58.5	49.4	3.9	56.5	29.5	0.2	60.3	44.8	11.8
Queue Length 50th (ft)	206	110	16	30	138	0	233	164	0	54	187	23
Queue Length 95th (ft)	#381	175	132	75	212	16	#428	251	0	116	272	102
Internal Link Dist (ft)		1709			528			668			695	
Turn Bay Length (ft)	425		200	200		50	430		98	190		160
Base Capacity (vph)	496	1227	941	628	1306	638	754	1488	711	223	1157	660
Starvation Cap Reductn	0	0	0	0	0	0	0	0	0	0	0	0
Spillback Cap Reductn	0	0	0	0	0	0	0	0	0	0	0	0
Storage Cap Reductn	0	0	0	0	0	0	0	0	0	0	0	0
Reduced v/c Ratio	0.64	0.32	0.67	0.07	0.30	0.10	0.87	0.38	0.06	0.35	0.47	0.40

Intersection Summary

# 95th percentile volume exceeds capacity, queue may be longer.  
Queue shown is maximum after two cycles.

Queues

2: Shiloh Road & Hembree Ln



Lane Group	EBL	EBT	WBL	WBT	NBL	NBT	SBL	SBT	SBR
Lane Group Flow (vph)	703	1289	110	1384	111	149	183	11	554
v/c Ratio	0.98	0.65	0.54	0.90	0.37	0.67	0.91	0.05	0.62
Control Delay (s/veh)	66.5	16.7	47.6	32.8	38.3	27.5	87.9	39.8	26.9
Queue Delay	0.0	0.0	0.0	0.0	0.0	0.0	0.0	0.0	0.0
Total Delay (s/veh)	66.5	16.7	47.6	32.8	38.3	27.5	87.9	39.8	26.9
Queue Length 50th (ft)	207	269	60	364	53	12	105	6	139
Queue Length 95th (ft)	#325	356	111	439	#136	#91	#232	23	173
Internal Link Dist (ft)		222		1709		136		492	
Turn Bay Length (ft)			100				350		
Base Capacity (vph)	715	1957	240	1579	301	220	199	198	883
Starvation Cap Reductn	0	0	0	0	0	0	0	0	0
Spillback Cap Reductn	0	0	0	0	0	0	0	0	0
Storage Cap Reductn	0	0	0	0	0	0	0	0	0
Reduced v/c Ratio	0.98	0.66	0.46	0.88	0.37	0.68	0.92	0.06	0.63

Intersection Summary

# 95th percentile volume exceeds capacity, queue may be longer.  
 Queue shown is maximum after two cycles.



Queues  
3: US 101 NB Off-Ramp & Shiloh Road



Lane Group	EBT	WBT	NBL	NBR
Lane Group Flow (vph)	952	1112	771	1043
v/c Ratio	0.73	0.86	0.89	0.75
Control Delay (s/veh)	19.1	25.0	29.5	14.9
Queue Delay	0.0	0.0	0.0	0.0
Total Delay (s/veh)	19.1	25.0	29.5	14.9
Queue Length 50th (ft)	137	172	209	135
Queue Length 95th (ft)	198	#282	#420	207
Internal Link Dist (ft)	106	291	689	
Turn Bay Length (ft)				340
Base Capacity (vph)	1332	1332	899	1444
Starvation Cap Reductn	0	0	0	0
Spillback Cap Reductn	0	0	0	0
Storage Cap Reductn	0	0	0	0
Reduced v/c Ratio	0.71	0.83	0.86	0.72

Intersection Summary

# 95th percentile volume exceeds capacity, queue may be longer.  
Queue shown is maximum after two cycles.

Queues

6: Conde Lane & Shiloh Road

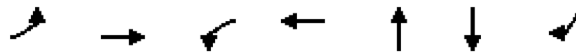

Lane Group	EBL	EBT	WBL	WBT	NBT	SBT	SBR
Lane Group Flow (vph)	88	823	11	1394	34	445	74
v/c Ratio	0.75	0.42	0.09	0.86	0.21	0.84	0.09
Control Delay (s/veh)	93.4	18.2	58.0	35.2	29.1	56.8	19.8
Queue Delay	0.0	0.0	0.0	0.0	0.0	0.0	0.0
Total Delay (s/veh)	93.4	18.2	58.0	35.2	29.1	56.8	19.8
Queue Length 50th (ft)	73	203	9	531	7	351	35
Queue Length 95th (ft)	#161	301	26	519	23	#517	64
Internal Link Dist (ft)		735		1001	338	442	
Turn Bay Length (ft)	90		127				65
Base Capacity (vph)	117	1950	117	1607	471	528	745
Starvation Cap Reductn	0	0	0	0	0	0	0
Spillback Cap Reductn	0	0	0	0	0	0	0
Storage Cap Reductn	0	0	0	0	0	0	0
Reduced v/c Ratio	0.75	0.42	0.09	0.87	0.07	0.84	0.10

Intersection Summary

# 95th percentile volume exceeds capacity, queue may be longer.  
 Queue shown is maximum after two cycles.

Queues

12: US 101 SB On Ramp/US 101 SB Off Ramp & Old Redwood Highway



Lane Group	EBT	EBR	WBL	WBT	SBL	SBT
Lane Group Flow (vph)	651	533	498	1260	359	326
v/c Ratio	0.57	0.62	0.95	0.54	0.92	0.78
Control Delay (s/veh)	28.3	5.8	61.2	9.2	65.1	39.0
Queue Delay	0.0	0.0	0.0	0.0	0.0	0.0
Total Delay (s/veh)	28.3	5.8	61.2	9.2	65.1	39.0
Queue Length 50th (ft)	163	0	274	179	209	140
Queue Length 95th (ft)	220	75	#460	225	#329	#220
Internal Link Dist (ft)	343			451		751
Turn Bay Length (ft)			250		420	
Base Capacity (vph)	1124	858	534	2331	400	426
Starvation Cap Reductn	0	0	0	0	0	0
Spillback Cap Reductn	0	0	0	0	0	0
Storage Cap Reductn	0	0	0	0	0	0
Reduced v/c Ratio	0.58	0.62	0.93	0.54	0.90	0.77

Intersection Summary

# 95th percentile volume exceeds capacity, queue may be longer.  
 Queue shown is maximum after two cycles.

Queues

GP 2040+Project Alternative B\_Mitigations

1: Old Redwood Hwy & Shiloh Road

Timing Plan: Saturday Midday Peak



Lane Group	EBL	EBT	EBR	WBL	WBT	WBR	NBL	NBT	NBR	SBL	SBT	SBR
Lane Group Flow (vph)	204	534	338	36	593	88	338	377	38	87	312	292
v/c Ratio	0.60	0.36	0.40	0.22	0.66	0.18	0.58	0.42	0.07	0.56	0.51	0.57
Control Delay (s/veh)	41.0	19.1	3.8	43.5	32.5	4.1	39.6	29.0	0.3	57.3	36.2	9.4
Queue Delay	0.0	0.0	0.0	0.0	0.0	0.0	0.0	0.0	0.0	0.0	0.0	0.0
Total Delay (s/veh)	41.0	19.1	3.8	43.5	32.5	4.1	39.6	29.0	0.3	57.3	36.2	9.4
Queue Length 50th (ft)	96	107	0	18	143	0	82	84	0	44	76	0
Queue Length 95th (ft)	196	171	51	53	227	20	#175	158	0	#143	144	73
Internal Link Dist (ft)		1709			528			668			695	
Turn Bay Length (ft)	425		200	200		50	430		98	190		160
Base Capacity (vph)	661	1512	855	838	1697	818	598	1851	866	154	1543	843
Starvation Cap Reductn	0	0	0	0	0	0	0	0	0	0	0	0
Spillback Cap Reductn	0	0	0	0	0	0	0	0	0	0	0	0
Storage Cap Reductn	0	0	0	0	0	0	0	0	0	0	0	0
Reduced v/c Ratio	0.31	0.35	0.40	0.04	0.35	0.11	0.57	0.20	0.04	0.56	0.20	0.35

Intersection Summary

# 95th percentile volume exceeds capacity, queue may be longer.  
 Queue shown is maximum after two cycles.

Queues

2: Shiloh Road & Hembree Ln



Lane Group	EBL	EBT	WBL	WBT	NBL	NBT	SBL	SBT	SBR
Lane Group Flow (vph)	918	896	110	1031	110	149	236	11	856
v/c Ratio	0.91	0.45	0.79	0.84	0.33	0.71	0.87	0.05	0.71
Control Delay (s/veh)	51.1	14.0	86.5	38.0	41.3	32.7	76.5	48.8	26.4
Queue Delay	0.0	0.0	0.0	0.0	0.0	0.0	0.0	0.0	0.0
Total Delay (s/veh)	51.1	14.0	86.5	38.0	41.3	32.7	76.5	48.8	26.4
Queue Length 50th (ft)	319	173	77	325	62	14	162	7	246
Queue Length 95th (ft)	#455	220	#180	410	132	#108	#312	26	288
Internal Link Dist (ft)		222		1709		136		492	
Turn Bay Length (ft)			100				350		
Base Capacity (vph)	1019	2145	138	1366	351	208	276	213	1201
Starvation Cap Reductn	0	0	0	0	0	0	0	0	0
Spillback Cap Reductn	0	0	0	0	0	0	0	0	0
Storage Cap Reductn	0	0	0	0	0	0	0	0	0
Reduced v/c Ratio	0.90	0.42	0.80	0.75	0.31	0.72	0.86	0.05	0.71

Intersection Summary

# 95th percentile volume exceeds capacity, queue may be longer.  
 Queue shown is maximum after two cycles.

Queues  
 3: US 101 NB Off-Ramp & Shiloh Road



Lane Group	EBT	WBT	NBL	NBR
Lane Group Flow (vph)	775	1385	547	1093
v/c Ratio	0.48	0.86	0.79	0.90
Control Delay (s/veh)	12.4	21.6	26.7	26.2
Queue Delay	0.0	0.0	0.0	0.0
Total Delay (s/veh)	12.4	21.6	26.7	26.2
Queue Length 50th (ft)	96	220	168	168
Queue Length 95th (ft)	138	#313	#323	#306
Internal Link Dist (ft)	106	291	689	
Turn Bay Length (ft)				340
Base Capacity (vph)	1684	1684	720	1255
Starvation Cap Reductn	0	0	0	0
Spillback Cap Reductn	0	0	0	0
Storage Cap Reductn	0	0	0	0
Reduced v/c Ratio	0.46	0.82	0.76	0.87

Intersection Summary

# 95th percentile volume exceeds capacity, queue may be longer.  
 Queue shown is maximum after two cycles.

Queues  
6: Conde Lane & Shiloh Road

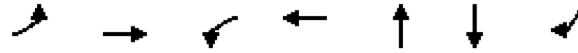

Lane Group	EBL	EBT	WBL	WBT	NBT	SBT	SBR
Lane Group Flow (vph)	45	575	14	1005	18	373	53
v/c Ratio	0.16	0.31	0.05	0.66	0.04	0.99	0.07
Control Delay (s/veh)	33.0	9.6	33.4	15.9	0.2	79.8	12.9
Queue Delay	0.0	0.0	0.0	0.0	0.0	0.0	0.0
Total Delay (s/veh)	33.0	9.6	33.4	15.9	0.2	79.8	12.9
Queue Length 50th (ft)	13	35	4	124	0	~143	10
Queue Length 95th (ft)	56	141	26	263	0	#392	31
Internal Link Dist (ft)		735		1001	338	442	
Turn Bay Length (ft)	90		127				65
Base Capacity (vph)	290	2693	273	2516	1074	375	1182
Starvation Cap Reductn	0	0	0	0	0	0	0
Spillback Cap Reductn	0	0	0	0	0	0	0
Storage Cap Reductn	0	0	0	0	0	0	0
Reduced v/c Ratio	0.16	0.21	0.05	0.40	0.02	0.99	0.04

**Intersection Summary**

~ Volume exceeds capacity, queue is theoretically infinite.  
Queue shown is maximum after two cycles.

# 95th percentile volume exceeds capacity, queue may be longer.  
Queue shown is maximum after two cycles.

Queues



Lane Group	EBT	EBR	WBL	WBT	SBL	SBT
Lane Group Flow (vph)	713	543	632	1060	193	177
v/c Ratio	0.60	0.70	0.93	0.39	0.84	0.62
Control Delay (s/veh)	28.1	13.9	50.0	4.0	70.0	30.9
Queue Delay	0.0	0.0	0.0	0.0	0.0	0.0
Total Delay (s/veh)	28.1	13.9	50.0	4.0	70.0	30.9
Queue Length 50th (ft)	181	73	331	85	113	53
Queue Length 95th (ft)	242	204	#545	110	#235	126
Internal Link Dist (ft)	343			451		751
Turn Bay Length (ft)			250		420	
Base Capacity (vph)	1176	768	700	2703	234	288
Starvation Cap Reductn	0	0	0	0	0	0
Spillback Cap Reductn	0	0	0	0	0	0
Storage Cap Reductn	0	0	0	0	0	0
Reduced v/c Ratio	0.61	0.71	0.90	0.39	0.82	0.61

Intersection Summary























# 95th percentile volume exceeds capacity, queue may be longer.  
 Queue shown is maximum after two cycles.



Lanes, Volumes, Timings  
1: Old Redwood Hwy & Shiloh Road

General Plan 2040 Project Altern. B Conditions

Timing Plan: A.M. PEAK

												
Lane Group	EBL	EBT	EBR	WBL	WBT	WBR	NBL	NBT	NBR	SBL	SBT	SBR
Lane Configurations												
Traffic Volume (vph)	313	310	440	40	242	29	364	312	18	53	479	398
Future Volume (vph)	313	310	440	40	242	29	364	312	18	53	479	398
Ideal Flow (vphpl)	1900	1900	1900	1900	1900	1900	1900	1900	1900	1900	1900	1900
Storage Length (ft)	375		140	0		50	200		98	130		93
Storage Lanes	1		1	0		1	1		1	1		1
Taper Length (ft)	50			25			60			93		
Lane Util. Factor	1.00	1.00	1.00	1.00	1.00	1.00	1.00	1.00	1.00	1.00	1.00	1.00
Ped Bike Factor												0.98
Frt			0.850			0.850			0.850			0.850
Flt Protected	0.950				0.993		0.950			0.950		
Satd. Flow (prot)	1770	1863	1583	0	1850	1583	1770	1863	1583	1770	1863	1583
Flt Permitted	0.950				0.993		0.950			0.950		
Satd. Flow (perm)	1770	1863	1583	0	1850	1583	1770	1863	1583	1770	1863	1549
Right Turn on Red			Yes			Yes			Yes			Yes
Satd. Flow (RTOR)			322			105			77			141
Link Speed (mph)		40			40			45			40	
Link Distance (ft)		1789			608			748			775	
Travel Time (s)		30.5			10.4			11.3			13.2	
Confl. Bikes (#/hr)												1
Peak Hour Factor	0.81	0.81	0.81	0.89	0.89	0.89	0.93	0.93	0.93	0.85	0.85	0.85
Adj. Flow (vph)	386	383	543	45	272	33	391	335	19	62	564	468
Shared Lane Traffic (%)												
Lane Group Flow (vph)	386	383	543	0	317	33	391	335	19	62	564	468
Enter Blocked Intersection	No	No	No	No	No	No	No	No	No	No	No	No
Lane Alignment	Left	Left	Right	Left	Left	Right	Left	Left	Right	Left	Left	Right
Median Width(ft)		12			12			12			12	
Link Offset(ft)		0			0			0			0	
Crosswalk Width(ft)		16			16			16			16	
Two way Left Turn Lane												
Headway Factor	1.00	1.00	1.00	1.00	1.00	1.00	1.00	1.00	1.00	1.00	1.00	1.00
Turning Speed (mph)	15		9	15		9	15		9	15		9
Number of Detectors	1	2	1	1	2	1	1	2	1	1	2	1
Detector Template	Left	Thru	Right	Left	Thru	Right	Left	Thru	Right	Left	Thru	Right
Leading Detector (ft)	20	100	20	20	100	20	20	100	20	20	100	20
Trailing Detector (ft)	0	0	0	0	0	0	0	0	0	0	0	0
Detector 1 Position(ft)	0	0	0	0	0	0	0	0	0	0	0	0
Detector 1 Size(ft)	20	6	20	20	6	20	20	6	20	20	6	20
Detector 1 Type	Cl+Ex	Cl+Ex	Cl+Ex	Cl+Ex	Cl+Ex	Cl+Ex	Cl+Ex	Cl+Ex	Cl+Ex	Cl+Ex	Cl+Ex	Cl+Ex
Detector 1 Channel												
Detector 1 Extend (s)	0.0	0.0	0.0	0.0	0.0	0.0	0.0	0.0	0.0	0.0	0.0	0.0
Detector 1 Queue (s)	0.0	0.0	0.0	0.0	0.0	0.0	0.0	0.0	0.0	0.0	0.0	0.0
Detector 1 Delay (s)	0.0	0.0	0.0	0.0	0.0	0.0	0.0	0.0	0.0	0.0	0.0	0.0
Detector 2 Position(ft)		94			94			94			94	
Detector 2 Size(ft)		6			6			6			6	
Detector 2 Type		Cl+Ex			Cl+Ex			Cl+Ex			Cl+Ex	
Detector 2 Channel												
Detector 2 Extend (s)		0.0			0.0			0.0			0.0	
Turn Type	Split	NA	Perm	Split	NA	Perm	Prot	NA	Perm	Prot	NA	Perm

Lanes, Volumes, Timings  
1: Old Redwood Hwy & Shiloh Road

General Plan 2040 Project Altern. B Conditions

Timing Plan: A.M. PEAK

Lane Group	EBL	EBT	EBR	WBL	WBT	WBR	NBL	NBT	NBR	SBL	SBT	SBR
Protected Phases	2	2		6	6		3	8		7	4	
Permitted Phases			2			6			8			4
Detector Phase	2	2	2	6	6	6	3	8	8	7	4	4
Switch Phase												
Minimum Initial (s)	5.0	5.0	5.0	5.0	5.0	5.0	5.0	5.0	5.0	5.0	5.0	5.0
Minimum Split (s)	34.5	34.5	34.5	42.5	42.5	42.5	8.5	46.5	46.5	8.5	39.5	39.5
Total Split (s)	35.0	35.0	35.0	42.5	42.5	42.5	18.0	48.0	48.0	9.5	39.5	39.5
Total Split (%)	25.9%	25.9%	25.9%	31.5%	31.5%	31.5%	13.3%	35.6%	35.6%	7.0%	29.3%	29.3%
Maximum Green (s)	30.5	30.5	30.5	38.0	38.0	38.0	14.5	43.5	43.5	6.0	35.0	35.0
Yellow Time (s)	3.5	3.5	3.5	3.5	3.5	3.5	3.0	3.5	3.5	3.0	3.5	3.5
All-Red Time (s)	1.0	1.0	1.0	1.0	1.0	1.0	0.5	1.0	1.0	0.5	1.0	1.0
Lost Time Adjust (s)	0.0	0.0	0.0		0.0	0.0	0.0	0.0	0.0	0.0	0.0	0.0
Total Lost Time (s)	4.5	4.5	4.5		4.5	4.5	3.5	4.5	4.5	3.5	4.5	4.5
Lead/Lag	Lead	Lead	Lead	Lag	Lag	Lag	Lead	Lag	Lag	Lead	Lag	Lag
Lead-Lag Optimize?	Yes	Yes	Yes	Yes	Yes	Yes	Yes	Yes	Yes	Yes	Yes	Yes
Vehicle Extension (s)	3.0	3.0	3.0	3.0	3.0	3.0	3.0	3.0	3.0	3.0	3.0	3.0
Recall Mode	None	None	None	None	None	None	None	None	None	None	None	None
Walk Time (s)	7.0	7.0	7.0	7.0	7.0	7.0		7.0	7.0		7.0	7.0
Flash Don't Walk (s)	23.0	23.0	23.0	31.0	31.0	31.0		35.0	35.0		28.0	28.0
Pedestrian Calls (#/hr)	0	0	0	0	0	0		0	0		0	0
Act Effct Green (s)	30.5	30.5	30.5		26.1	26.1	14.5	43.6	43.6	6.0	35.1	35.1
Actuated g/C Ratio	0.25	0.25	0.25		0.21	0.21	0.12	0.35	0.35	0.05	0.28	0.28
v/c Ratio	0.88	0.83	0.86		0.81	0.08	1.88	0.51	0.03	0.72	1.06	0.87
Control Delay (s/veh)	67.9	61.5	32.6		62.6	0.4	443.1	35.9	0.1	100.8	99.9	46.9
Queue Delay	0.0	0.0	0.0		0.0	0.0	0.0	0.0	0.0	0.0	0.0	0.0
Total Delay (s/veh)	67.9	61.5	32.6		62.6	0.4	443.1	35.9	0.1	100.8	99.9	46.9
LOS	E	E	C		E	A	F	D	A	F	F	D
Approach Delay (s/veh)		51.4			56.7			248.7			77.3	
Approach LOS		D			E			F			E	

Intersection Summary

Area Type:	Other
Cycle Length:	135
Actuated Cycle Length:	123.2
Natural Cycle:	145
Control Type:	Actuated-Uncoordinated
Maximum v/c Ratio:	1.88
Intersection Signal Delay (s/veh):	102.0
Intersection LOS:	F
Intersection Capacity Utilization:	92.2%
ICU Level of Service:	F
Analysis Period (min):	15



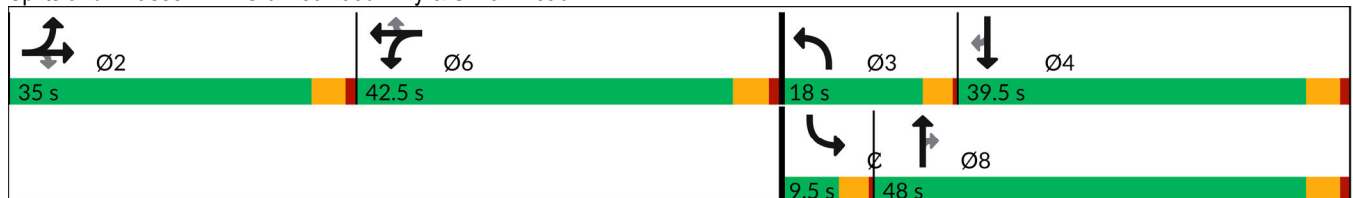



















Splits and Phases: 1: Old Redwood Hwy & Shiloh Road



Lanes, Volumes, Timings  
2: Shiloh Road & Hembree Ln

General Plan 2040 Project Altern. B Conditions

Timing Plan: A.M. PEAK

												
Lane Group	EBL	EBT	EBR	WBL	WBT	WBR	NBL	NBT	NBR	SBL	SBT	SBR
Lane Configurations	 				 						 	
Traffic Volume (vph)	311	918	103	49	865	90	49	11	16	129	18	570
Future Volume (vph)	311	918	103	49	865	90	49	11	16	129	18	570
Ideal Flow (vphpl)	1900	1900	1900	1900	1900	1900	1900	1900	1900	1900	1900	1900
Storage Length (ft)	0		0	100		130	0		0	0		0
Storage Lanes	2		0	1		1	1		0	0		1
Taper Length (ft)	25			50			25			25		
Lane Util. Factor	0.97	1.00	1.00	1.00	0.95	0.95	1.00	1.00	1.00	1.00	1.00	1.00
Frt		0.987			0.986			0.911				0.850
Flt Protected	0.950			0.950			0.950				0.958	
Satd. Flow (prot)	3433	1839	0	1770	3490	0	1770	1697	0	0	1785	1583
Flt Permitted	0.950			0.950			0.950				0.958	
Satd. Flow (perm)	3433	1839	0	1770	3490	0	1770	1697	0	0	1785	1583
Right Turn on Red			Yes			Yes			Yes			Yes
Satd. Flow (RTOR)		10			16			16				119
Link Speed (mph)		40			40			30				35
Link Distance (ft)		302			1789			216				381
Travel Time (s)		5.1			30.5			4.9				7.4
Peak Hour Factor	0.88	0.88	1.00	1.00	0.97	0.97	1.00	1.00	1.00	0.94	1.00	0.94
Adj. Flow (vph)	353	1043	103	49	892	93	49	11	16	137	18	606
Shared Lane Traffic (%)												
Lane Group Flow (vph)	353	1146	0	49	985	0	49	27	0	0	155	606
Enter Blocked Intersection	No	No	No	No	No	No	No	No	No	No	No	No
Lane Alignment	Left	Left	Right	Left	Left	Right	Left	Left	Right	Left	Left	Right
Median Width(ft)		24			24			12				12
Link Offset(ft)		0			0			0				0
Crosswalk Width(ft)		16			16			16				16
Two way Left Turn Lane												
Headway Factor	1.00	1.00	1.00	1.00	1.00	1.00	1.00	1.00	1.00	1.00	1.00	1.00
Turning Speed (mph)	15		60	60		9	60		60	15		9
Number of Detectors	1	2		1	2		1	2		1	2	1
Detector Template	Left	Thru		Left	Thru		Left	Thru		Left	Thru	Right
Leading Detector (ft)	20	100		20	100		20	100		20	100	20
Trailing Detector (ft)	0	0		0	0		0	0		0	0	0
Detector 1 Position(ft)	0	0		0	0		0	0		0	0	0
Detector 1 Size(ft)	20	6		20	6		20	6		20	6	20
Detector 1 Type	Cl+Ex	Cl+Ex		Cl+Ex	Cl+Ex		Cl+Ex	Cl+Ex		Cl+Ex	Cl+Ex	Cl+Ex
Detector 1 Channel												
Detector 1 Extend (s)	0.0	0.0		0.0	0.0		0.0	0.0		0.0	0.0	0.0
Detector 1 Queue (s)	0.0	0.0		0.0	0.0		0.0	0.0		0.0	0.0	0.0
Detector 1 Delay (s)	0.0	0.0		0.0	0.0		0.0	0.0		0.0	0.0	0.0
Detector 2 Position(ft)		94			94			94				94
Detector 2 Size(ft)		6			6			6				6
Detector 2 Type		Cl+Ex			Cl+Ex			Cl+Ex				Cl+Ex
Detector 2 Channel												
Detector 2 Extend (s)		0.0			0.0			0.0				0.0
Turn Type	Prot	NA		Prot	NA		Split	NA		Split	NA	pt+ov
Protected Phases	5	2		1	6		8	8		4	4	4
Permitted Phases												

Lanes, Volumes, Timings  
2: Shiloh Road & Hembree Ln

General Plan 2040 Project Altern. B Conditions

Timing Plan: A.M. PEAK

Lane Group	EBL	EBT	EBR	WBL	WBT	WBR	NBL	NBT	NBR	SBL	SBT	SBR
Detector Phase	5	2		1	6		8	8		4	4	4 5
Switch Phase												
Minimum Initial (s)	3.0	5.0		5.0	5.0		5.0	5.0		5.0	5.0	
Minimum Split (s)	7.5	9.5		9.5	43.5		9.5	9.5		9.5	9.5	
Total Split (s)	21.0	57.0		9.5	45.5		9.5	9.5		14.0	14.0	
Total Split (%)	23.3%	63.3%		10.6%	50.6%		10.6%	10.6%		15.6%	15.6%	
Maximum Green (s)	17.0	53.0		5.5	41.5		5.5	5.5		10.0	10.0	
Yellow Time (s)	3.0	3.0		3.0	3.0		3.0	3.0		3.0	3.0	
All-Red Time (s)	1.0	1.0		1.0	1.0		1.0	1.0		1.0	1.0	
Lost Time Adjust (s)	0.0	0.0		0.0	0.0		0.0	0.0		0.0	0.0	
Total Lost Time (s)	4.0	4.0		4.0	4.0		4.0	4.0		4.0	4.0	
Lead/Lag	Lead	Lag		Lead	Lag							
Lead-Lag Optimize?	Yes	Yes		Yes	Yes							
Vehicle Extension (s)	3.0	3.0		3.0	3.0		3.0	3.0		3.0	3.0	
Recall Mode	None	None		None	None		None	None		None	None	
Walk Time (s)					7.0							
Flash Don't Walk (s)					32.0							
Pedestrian Calls (#/hr)					1							
Act Effct Green (s)	17.2	53.5		5.5	37.6		5.5	5.5		10.1	28.2	
Actuated g/C Ratio	0.20	0.63		0.07	0.45		0.07	0.07		0.12	0.33	
v/c Ratio	0.51	0.98		0.42	0.63		0.42	0.21		0.73	1.00	
Control Delay (s/veh)	34.1	40.8		51.9	20.0		51.9	28.9		58.9	59.3	
Queue Delay	0.0	11.5		0.0	0.0		0.0	0.0		0.0	0.0	
Total Delay (s/veh)	34.1	52.3		51.9	20.0		51.9	28.9		58.9	59.3	
LOS	C	D		D	B		D	C		E	E	
Approach Delay (s/veh)		48.0			21.5			43.7			59.2	
Approach LOS		D			C			D			E	

Intersection Summary

Area Type:	Other
Cycle Length:	90
Actuated Cycle Length:	84.3
Natural Cycle:	120
Control Type:	Actuated-Uncoordinated
Maximum v/c Ratio:	1.00
Intersection Signal Delay (s/veh):	42.3
Intersection LOS:	D
Intersection Capacity Utilization:	83.5%
ICU Level of Service:	E
Analysis Period (min):	15

Splits and Phases: 2: Shiloh Road & Hembree Ln



Lanes, Volumes, Timings  
3: US 101 NB Off-Ramp & Shiloh Road

General Plan 2040 Project Altern. B Conditions

Timing Plan: A.M. PEAK

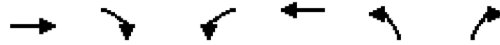

Lane Group	EBT	EBR	WBL	WBT	NBL	NBR
Lane Configurations	↑↑			↑	↘	↗↗
Traffic Volume (vph)	731	0	0	1103	813	602
Future Volume (vph)	731	0	0	1103	813	602
Ideal Flow (vphpl)	1900	1900	1900	1900	1900	1900
Storage Length (ft)		0	0		0	265
Storage Lanes		0	0		1	2
Taper Length (ft)			25		25	
Lane Util. Factor	0.95	1.00	1.00	1.00	1.00	0.88
Frt						0.850
Flt Protected					0.950	
Satd. Flow (prot)	3539	0	0	1863	1770	2787
Flt Permitted					0.950	
Satd. Flow (perm)	3539	0	0	1863	1770	2787
Right Turn on Red		Yes				Yes
Satd. Flow (RTOR)						189
Link Speed (mph)	40			40	30	
Link Distance (ft)	186			371	769	
Travel Time (s)	3.2			6.3	17.5	
Peak Hour Factor	0.91	0.91	0.90	0.90	0.76	0.76
Adj. Flow (vph)	803	0	0	1226	1070	792
Shared Lane Traffic (%)						
Lane Group Flow (vph)	803	0	0	1226	1070	792
Enter Blocked Intersection	No	No	No	No	No	No
Lane Alignment	Left	Right	Left	Left	Left	Right
Median Width(ft)	0			0	12	
Link Offset(ft)	0			0	0	
Crosswalk Width(ft)	16			16	16	
Two way Left Turn Lane						
Headway Factor	1.00	1.00	1.00	1.00	1.00	1.00
Turning Speed (mph)		9	15		15	9
Number of Detectors	2			2	1	1
Detector Template	Thru			Thru	Left	Right
Leading Detector (ft)	100			100	20	20
Trailing Detector (ft)	0			0	0	0
Detector 1 Position(ft)	0			0	0	0
Detector 1 Size(ft)	6			6	20	20
Detector 1 Type	Cl+Ex			Cl+Ex	Cl+Ex	Cl+Ex
Detector 1 Channel						
Detector 1 Extend (s)	0.0			0.0	0.0	0.0
Detector 1 Queue (s)	0.0			0.0	0.0	0.0
Detector 1 Delay (s)	0.0			0.0	0.0	0.0
Detector 2 Position(ft)	94			94		
Detector 2 Size(ft)	6			6		
Detector 2 Type	Cl+Ex			Cl+Ex		
Detector 2 Channel						
Detector 2 Extend (s)	0.0			0.0		
Turn Type	NA			NA	Prot	Perm
Protected Phases	2			6	8	
Permitted Phases						8

Lanes, Volumes, Timings  
 3: US 101 NB Off-Ramp & Shiloh Road

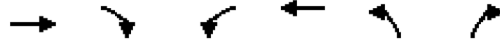

Lane Group	EBT	EBR	WBL	WBT	NBL	NBR
Detector Phase	2			6	8	8
Switch Phase						
Minimum Initial (s)	5.0			5.0	5.0	5.0
Minimum Split (s)	9.0			9.0	9.0	9.0
Total Split (s)	37.0			37.0	35.0	35.0
Total Split (%)	51.4%			51.4%	48.6%	48.6%
Maximum Green (s)	33.0			33.0	31.0	31.0
Yellow Time (s)	3.0			3.0	3.0	3.0
All-Red Time (s)	1.0			1.0	1.0	1.0
Lost Time Adjust (s)	0.0			0.0	0.0	0.0
Total Lost Time (s)	4.0			4.0	4.0	4.0
Lead/Lag						
Lead-Lag Optimize?						
Vehicle Extension (s)	3.0			3.0	3.0	3.0
Recall Mode	None			None	None	None
Act Effect Green (s)	33.0			33.0	31.0	31.0
Actuated g/C Ratio	0.46			0.46	0.43	0.43
v/c Ratio	0.50			1.44	1.40	0.61
Control Delay (s/veh)	15.0			225.6	212.4	14.0
Queue Delay	0.0			0.0	0.0	0.0
Total Delay (s/veh)	15.0			225.6	212.4	14.0
LOS	B			F	F	B
Approach Delay (s/veh)	15.0			225.6	128.1	
Approach LOS	B			F	F	

Intersection Summary

Area Type: Other  
 Cycle Length: 72  
 Actuated Cycle Length: 72  
 Natural Cycle: 130  
 Control Type: Actuated-Uncoordinated  
 Maximum v/c Ratio: 1.44  
 Intersection Signal Delay (s/veh): 135.5  
 Intersection LOS: F  
 Intersection Capacity Utilization 162.6%  
 ICU Level of Service H  
 Analysis Period (min) 15

Splits and Phases: 3: US 101 NB Off-Ramp & Shiloh Road



Lanes, Volumes, Timings  
4: Shiloh Road & US 101 SB Off-Ramp

General Plan 2040 Project Altern. B Conditions  
Timing Plan: A.M. PEAK



Lane Group	EBL	EBT	WBT	WBR	SBL	SBR
Lane Configurations		↑	↑		↘	↗
Traffic Volume (vph)	0	422	1153	0	309	184
Future Volume (vph)	0	422	1153	0	309	184
Ideal Flow (vphpl)	1900	1900	1900	1900	1900	1900
Storage Length (ft)	0			0	0	275
Storage Lanes	0			0	1	1
Taper Length (ft)	25				25	
Lane Util. Factor	1.00	1.00	1.00	1.00	1.00	1.00
Frt						0.850
Flt Protected					0.950	
Satd. Flow (prot)	0	1863	1863	0	1770	1583
Flt Permitted					0.950	
Satd. Flow (perm)	0	1863	1863	0	1770	1583
Right Turn on Red				Yes		Yes
Satd. Flow (RTOR)						107
Link Speed (mph)		40	40		30	
Link Distance (ft)		225	306		486	
Travel Time (s)		3.8	5.2		11.0	
Peak Hour Factor	0.93	0.93	0.91	0.91	0.92	0.92
Adj. Flow (vph)	0	454	1267	0	336	200
Shared Lane Traffic (%)						
Lane Group Flow (vph)	0	454	1267	0	336	200
Enter Blocked Intersection	No	No	No	No	No	No
Lane Alignment	Left	Left	Left	Right	Left	Right
Median Width(ft)		4	0		12	
Link Offset(ft)		0	0		0	
Crosswalk Width(ft)		16	16		16	
Two way Left Turn Lane						
Headway Factor	1.00	1.00	1.00	1.00	1.00	1.00
Turning Speed (mph)	15			9	15	9
Number of Detectors		2	2		1	1
Detector Template		Thru	Thru		Left	Right
Leading Detector (ft)		100	100		20	20
Trailing Detector (ft)		0	0		0	0
Detector 1 Position(ft)		0	0		0	0
Detector 1 Size(ft)		6	6		20	20
Detector 1 Type		Cl+Ex	Cl+Ex		Cl+Ex	Cl+Ex
Detector 1 Channel						
Detector 1 Extend (s)		0.0	0.0		0.0	0.0
Detector 1 Queue (s)		0.0	0.0		0.0	0.0
Detector 1 Delay (s)		0.0	0.0		0.0	0.0
Detector 2 Position(ft)		94	94			
Detector 2 Size(ft)		6	6			
Detector 2 Type		Cl+Ex	Cl+Ex			
Detector 2 Channel						
Detector 2 Extend (s)		0.0	0.0			
Turn Type		NA	NA		Perm	Perm
Protected Phases		2	6			
Permitted Phases					4	4

Lanes, Volumes, Timings  
4: Shiloh Road & US 101 SB Off-Ramp



Lane Group	EBL	EBT	WBT	WBR	SBL	SBR
Detector Phase		2	6		4	4
Switch Phase						
Minimum Initial (s)		5.0	5.0		5.0	5.0
Minimum Split (s)		9.0	38.0		9.0	9.0
Total Split (s)		69.0	69.0		21.0	21.0
Total Split (%)		76.7%	76.7%		23.3%	23.3%
Maximum Green (s)		65.0	65.0		17.0	17.0
Yellow Time (s)		3.0	3.0		3.0	3.0
All-Red Time (s)		1.0	1.0		1.0	1.0
Lost Time Adjust (s)		0.0	0.0		0.0	0.0
Total Lost Time (s)		4.0	4.0		4.0	4.0
Lead/Lag						
Lead-Lag Optimize?						
Vehicle Extension (s)		3.0	3.0		3.0	3.0
Recall Mode		None	None		None	None
Walk Time (s)			7.0			
Flash Don't Walk (s)			27.0			
Pedestrian Calls (#/hr)			0			
Act Effct Green (s)		61.3	61.3		17.1	17.1
Actuated g/C Ratio		0.71	0.71		0.20	0.20
v/c Ratio		0.34	0.96		0.96	0.50
Control Delay (s/veh)		5.5	29.7		76.9	20.8
Queue Delay		0.0	0.0		0.0	0.0
Total Delay (s/veh)		5.5	29.7		76.9	20.8
LOS		A	C		E	C
Approach Delay (s/veh)		5.5	29.7		56.0	
Approach LOS		A	C		E	

Intersection Summary	
Area Type:	Other
Cycle Length:	90
Actuated Cycle Length:	86.5
Natural Cycle:	90
Control Type:	Actuated-Uncoordinated
Maximum v/c Ratio:	0.96
Intersection Signal Delay (s/veh):	31.1
Intersection LOS:	C
Intersection Capacity Utilization:	145.0%
ICU Level of Service:	H
Analysis Period (min):	15

Splits and Phases: 4: Shiloh Road & US 101 SB Off-Ramp

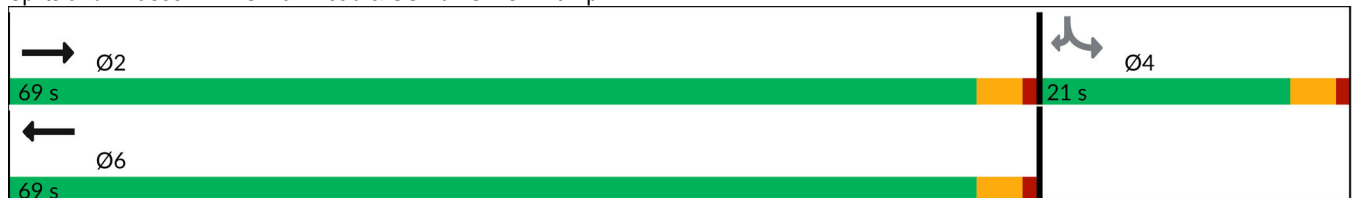



Lanes, Volumes, Timings  
5: Caletti Ave & Shiloh Road

General Plan 2040 Project Altern. B Conditions

Timing Plan: A.M. PEAK

	→	↘	↙	←	↖	↗
Lane Group	EBT	EBR	WBL	WBT	NBL	NBR
Lane Configurations	↑↑		↘	↑	↘	↗
Traffic Volume (vph)	900	14	130	1207	17	122
Future Volume (vph)	900	14	130	1207	17	122
Ideal Flow (vphpl)	1900	1900	1900	1900	1900	1900
Storage Length (ft)		0	68		0	0
Storage Lanes		0	1		1	1
Taper Length (ft)			50		25	
Lane Util. Factor	0.95	0.95	1.00	1.00	1.00	1.00
Frt	0.998					0.850
Flt Protected			0.950		0.950	
Satd. Flow (prot)	3532	0	1770	1863	1770	1583
Flt Permitted			0.950		0.950	
Satd. Flow (perm)	3532	0	1770	1863	1770	1583
Link Speed (mph)	40			40	30	
Link Distance (ft)	1081			184	459	
Travel Time (s)	18.4			3.1	10.4	
Peak Hour Factor	0.96	0.96	0.87	0.87	0.84	0.84
Adj. Flow (vph)	938	15	149	1387	20	145
Shared Lane Traffic (%)						
Lane Group Flow (vph)	953	0	149	1387	20	145
Enter Blocked Intersection	No	No	No	No	No	No
Lane Alignment	Left	Right	Left	Left	Left	Right
Median Width(ft)	12			12	12	
Link Offset(ft)	0			0	0	
Crosswalk Width(ft)	16			16	16	
Two way Left Turn Lane						
Headway Factor	1.00	1.00	1.00	1.00	1.00	1.00
Turning Speed (mph)		9	15		15	9
Sign Control	Free			Free	Stop	
<b>Intersection Summary</b>						
Area Type:	Other					
Control Type:	Unsignalized					
Intersection Capacity Utilization	73.5%			ICU Level of Service D		
Analysis Period (min)	15					

Lanes, Volumes, Timings  
6: Conde Lane & Shiloh Road

General Plan 2040 Project Altern. B Conditions

Timing Plan: A.M. PEAK

Lane Group	EBL	EBT	EBR	WBL	WBT	WBR	NBL	NBT	NBR	SBL	SBT	SBR
Lane Configurations												
Traffic Volume (vph)	55	535	3	8	854	298	2	1	9	363	0	27
Future Volume (vph)	55	535	3	8	854	298	2	1	9	363	0	27
Ideal Flow (vphpl)	1900	1900	1900	1900	1900	1900	1900	1900	1900	1900	1900	1900
Storage Length (ft)	90		0	127		0	0		0	0		40
Storage Lanes	1		0	1		0	0		0	0		1
Taper Length (ft)	70			40			25			25		
Lane Util. Factor	1.00	0.95	0.95	1.00	0.95	0.95	1.00	1.00	1.00	1.00	1.00	1.00
Frt		0.999			0.961			0.902				0.850
Flt Protected	0.950			0.950				0.991			0.950	
Satd. Flow (prot)	1770	3536	0	1770	3401	0	0	1665	0	0	1770	1583
Flt Permitted	0.950			0.950				0.991			0.950	
Satd. Flow (perm)	1770	3536	0	1770	3401	0	0	1665	0	0	1770	1583
Right Turn on Red			Yes			Yes			Yes			No
Satd. Flow (RTOR)		1			50			16				
Link Speed (mph)		40			40			30				35
Link Distance (ft)		815			1081			418				522
Travel Time (s)		13.9			18.4			9.5				10.2
Peak Hour Factor	0.95	0.95	0.95	0.85	0.85	0.85	0.57	0.57	0.57	0.86	0.86	0.86
Adj. Flow (vph)	58	563	3	9	1005	351	4	2	16	422	0	31
Shared Lane Traffic (%)												
Lane Group Flow (vph)	58	566	0	9	1356	0	0	22	0	0	422	31
Enter Blocked Intersection	No	No	No	No	No	No	No	No	No	No	No	No
Lane Alignment	Left	Left	Right	Left	Left	Right	Left	Left	Right	Left	Left	Right
Median Width(ft)		12			12			0				0
Link Offset(ft)		0			0			0				0
Crosswalk Width(ft)		16			16			16				16
Two way Left Turn Lane												
Headway Factor	1.00	1.00	1.00	1.00	1.00	1.00	1.00	1.00	1.00	1.00	1.00	1.00
Turning Speed (mph)	15		9	15		9	15		9	15		9
Number of Detectors	1	2		1	2		1	2		1	1	1
Detector Template	Left	Thru		Left	Thru		Left	Thru		Left	Thru	Right
Leading Detector (ft)	20	100		20	100		20	100		20	30	20
Trailing Detector (ft)	0	0		0	0		0	0		0	0	0
Detector 1 Position(ft)	0	0		0	0		0	0		0	0	0
Detector 1 Size(ft)	20	6		20	6		20	6		20	30	20
Detector 1 Type	Cl+Ex	Cl+Ex		Cl+Ex	Cl+Ex		Cl+Ex	Cl+Ex		Cl+Ex	Cl+Ex	Cl+Ex
Detector 1 Channel												
Detector 1 Extend (s)	0.0	0.0		0.0	0.0		0.0	0.0		0.0	0.0	0.0
Detector 1 Queue (s)	0.0	0.0		0.0	0.0		0.0	0.0		0.0	0.0	0.0
Detector 1 Delay (s)	0.0	0.0		0.0	0.0		0.0	0.0		0.0	0.0	0.0
Detector 2 Position(ft)		94			94			94				
Detector 2 Size(ft)		6			6			6				
Detector 2 Type		Cl+Ex			Cl+Ex			Cl+Ex				
Detector 2 Channel												
Detector 2 Extend (s)		0.0			0.0			0.0				
Turn Type	Prot	NA		Prot	NA		Split	NA		Split	NA	custom
Protected Phases	5	2		1	6		7	7		4	4	
Permitted Phases												6

Lanes, Volumes, Timings  
6: Conde Lane & Shiloh Road

General Plan 2040 Project Altern. B Conditions

Timing Plan: A.M. PEAK

Lane Group	EBL	EBT	EBR	WBL	WBT	WBR	NBL	NBT	NBR	SBL	SBT	SBR
Detector Phase	5	2		1	6		7	7		4	4	6
Switch Phase												
Minimum Initial (s)	8.0	8.0		8.0	8.0		10.0	10.0		11.0	11.0	8.0
Minimum Split (s)	12.0	46.0		12.0	12.0		37.0	37.0		15.0	15.0	12.0
Total Split (s)	13.0	46.0		12.0	45.0		37.0	37.0		15.0	15.0	45.0
Total Split (%)	11.8%	41.8%		10.9%	40.9%		33.6%	33.6%		13.6%	13.6%	40.9%
Maximum Green (s)	9.0	42.0		8.0	41.0		33.0	33.0		11.0	11.0	41.0
Yellow Time (s)	3.0	3.0		3.0	3.0		3.0	3.0		3.0	3.0	3.0
All-Red Time (s)	1.0	1.0		1.0	1.0		1.0	1.0		1.0	1.0	1.0
Lost Time Adjust (s)	0.0	0.0		0.0	0.0		0.0	0.0		0.0	0.0	0.0
Total Lost Time (s)	4.0	4.0		4.0	4.0		4.0	4.0		4.0	4.0	4.0
Lead/Lag	Lead	Lag		Lead	Lag							Lag
Lead-Lag Optimize?	Yes	Yes		Yes	Yes							Yes
Vehicle Extension (s)	3.0	3.0		3.0	3.0		3.0	3.0		3.0	3.0	3.0
Recall Mode	None	None		None	None		None	None		None	None	None
Walk Time (s)		7.0					7.0	7.0				
Flash Don't Walk (s)		35.0					26.0	26.0				
Pedestrian Calls (#/hr)		0					0	0				
Act Effct Green (s)	8.6	46.9		8.2	42.1		10.3			11.3	42.1	
Actuated g/C Ratio	0.12	0.64		0.11	0.58		0.14			0.15	0.58	
v/c Ratio	0.28	0.25		0.05	0.69		0.09			1.55	0.03	
Control Delay (s/veh)	37.6	7.7		35.8	15.7		20.8			290.6	11.2	
Queue Delay	0.0	0.0		0.0	0.0		0.0			0.0	0.0	
Total Delay (s/veh)	37.6	7.7		35.8	15.7		20.8			290.6	11.2	
LOS	D	A		D	B		C			F	B	
Approach Delay (s/veh)		10.5			15.8		20.8			271.5		
Approach LOS		B			B		C			F		

Intersection Summary

Area Type:	Other
Cycle Length:	110
Actuated Cycle Length:	73.2
Natural Cycle:	140
Control Type:	Actuated-Uncoordinated
Maximum v/c Ratio:	1.55
Intersection Signal Delay (s/veh):	61.5
Intersection LOS:	E
Intersection Capacity Utilization:	76.6%
ICU Level of Service:	D
Analysis Period (min):	15

Splits and Phases: 6: Conde Lane & Shiloh Road



Lanes, Volumes, Timings  
7: Driveway 1/Gridley Drive & Shiloh Road

General Plan 2040 Project Altern. B Conditions

Timing Plan: A.M. PEAK





















Lane Group	EBL	EBT	EBR	WBL	WBT	WBR	NBL	NBT	NBR	SBL	SBT	SBR
Lane Configurations												
Traffic Volume (vph)	12	353	47	0	187	0	33	0	0	1	0	24
Future Volume (vph)	12	353	47	0	187	0	33	0	0	1	0	24
Ideal Flow (vphp)	1900	1900	1900	1900	1900	1900	1900	1900	1900	1900	1900	1900
Storage Length (ft)	0		150	0		0	0		0	0		0
Storage Lanes	0		1	0		0	1		0	0		0
Taper Length (ft)	25			25			25			25		
Lane Util. Factor	1.00	1.00	1.00	1.00	1.00	1.00	1.00	1.00	1.00	1.00	1.00	1.00
Ped Bike Factor												
Frt			0.850									0.869
Flt Protected		0.998					0.950					0.999
Satd. Flow (prot)	0	1859	1583	0	1863	0	1770	1863	0	0	1617	0
Flt Permitted		0.998					0.950					0.999
Satd. Flow (perm)	0	1859	1583	0	1863	0	1770	1863	0	0	1617	0
Link Speed (mph)		40			40			30			30	
Link Distance (ft)		608			2146			248			715	
Travel Time (s)		10.4			36.6			5.6			16.3	
Confl. Bikes (#/hr)			1									
Peak Hour Factor	0.91	0.91	0.91	0.85	0.85	0.85	1.00	1.00	1.00	0.71	0.71	0.71
Adj. Flow (vph)	13	388	52	0	220	0	33	0	0	1	0	34
Shared Lane Traffic (%)												
Lane Group Flow (vph)	0	401	52	0	220	0	33	0	0	0	35	0
Enter Blocked Intersection	No	No	No	No	No	No	No	No	No	No	No	No
Lane Alignment	Left	Left	Right	Left	Left	Right	Left	Left	Right	Left	Left	Right
Median Width(ft)		0			0			12			12	
Link Offset(ft)		0			0			0			0	
Crosswalk Width(ft)		16			16			16			16	
Two way Left Turn Lane												
Headway Factor	1.00	1.00	1.00	1.00	1.00	1.00	1.00	1.00	1.00	1.00	1.00	1.00
Turning Speed (mph)	15		9	15		9	15		9	15		9
Sign Control		Free			Free			Stop			Stop	

Intersection Summary	
Area Type:	Other
Control Type:	Unsignalized
Intersection Capacity Utilization	43.4%
	ICU Level of Service A
Analysis Period (min)	15

Lanes, Volumes, Timings  
8: Old Redwood Hwy & Driveway 2

General Plan 2040 Project Altern. B Conditions

Timing Plan: A.M. PEAK

												
Lane Group	EBL	EBT	EBR	WBL	WBT	WBR	NBL	NBT	NBR	SBL	SBT	SBR
Lane Configurations												
Traffic Volume (vph)	1	0	0	19	0	31	0	662	28	45	914	0
Future Volume (vph)	1	0	0	19	0	31	0	662	28	45	914	0
Ideal Flow (vphp)	1900	1900	1900	1900	1900	1900	1900	1900	1900	1900	1900	1900
Storage Length (ft)	0		0	0		0	0		100	50		0
Storage Lanes	0		0	1		0	0		1	1		0
Taper Length (ft)	25			25			25			25		
Lane Util. Factor	1.00	1.00	1.00	1.00	1.00	1.00	1.00	1.00	1.00	1.00	1.00	1.00
Ped Bike Factor												
Frt					0.850				0.850			
Flt Protected		0.950		0.950						0.950		
Satd. Flow (prot)	0	1770	0	1770	1583	0	0	1863	1583	1770	1863	0
Flt Permitted		0.950		0.950						0.950		
Satd. Flow (perm)	0	1770	0	1770	1583	0	0	1863	1583	1770	1863	0
Link Speed (mph)		30			30			45			45	
Link Distance (ft)		98			385			520			748	
Travel Time (s)		2.2			8.8			7.9			11.3	
Confl. Peds. (#/hr)									1	1		
Confl. Bikes (#/hr)									1			2
Peak Hour Factor	0.25	0.25	0.25	1.00	1.00	1.00	0.99	0.99	0.99	0.90	0.90	0.90
Adj. Flow (vph)	4	0	0	19	0	31	0	669	28	50	1016	0
Shared Lane Traffic (%)												
Lane Group Flow (vph)	0	4	0	19	31	0	0	669	28	50	1016	0
Enter Blocked Intersection	No	No	No	No	No	No	No	No	No	No	No	No
Lane Alignment	Left	Left	Right	Left	Left	Right	Left	Left	Right	Left	Left	Right
Median Width(ft)		12			12			12			12	
Link Offset(ft)		0			0			0			0	
Crosswalk Width(ft)		16			16			16			16	
Two way Left Turn Lane												
Headway Factor	1.00	1.00	1.00	1.00	1.00	1.00	1.00	1.00	1.00	1.00	1.00	1.00
Turning Speed (mph)	15		9	15		9	15		9	15		9
Sign Control		Stop			Stop			Free			Free	

Intersection Summary

Area Type:	Other
Control Type:	Unsignalized
Intersection Capacity Utilization	65.1%
Analysis Period (min)	15
	ICU Level of Service C

Lanes, Volumes, Timings  
9: Driveway 3 & Shiloh Road

General Plan 2040 Project Altern. B Conditions

Timing Plan: A.M. PEAK

	→	↘	↙	←	↖	↗
Lane Group	EBT	EBR	WBL	WBT	NBL	NBR
Lane Configurations	↑	↗		↖	↘	↗
Traffic Volume (vph)	207	145	14	77	101	10
Future Volume (vph)	207	145	14	77	101	10
Ideal Flow (vphpl)	1900	1900	1900	1900	1900	1900
Storage Length (ft)		200	0		0	0
Storage Lanes		1	0		1	1
Taper Length (ft)			25		25	
Lane Util. Factor	1.00	1.00	1.00	1.00	1.00	1.00
Frt		0.850				0.850
Flt Protected				0.992	0.950	
Satd. Flow (prot)	1863	1583	0	1848	1770	1583
Flt Permitted				0.992	0.950	
Satd. Flow (perm)	1863	1583	0	1848	1770	1583
Link Speed (mph)	40			40	30	
Link Distance (ft)	2146			134	402	
Travel Time (s)	36.6			2.3	9.1	
Peak Hour Factor	0.85	0.85	0.81	0.81	1.00	1.00
Adj. Flow (vph)	244	171	17	95	101	10
Shared Lane Traffic (%)						
Lane Group Flow (vph)	244	171	0	112	101	10
Enter Blocked Intersection	No	No	No	No	No	No
Lane Alignment	Left	Right	Left	Left	Left	Right
Median Width(ft)	0			0	12	
Link Offset(ft)	0			0	0	
Crosswalk Width(ft)	16			16	16	
Two way Left Turn Lane						
Headway Factor	1.00	1.00	1.00	1.00	1.00	1.00
Turning Speed (mph)		9	15		15	9
Sign Control	Free			Free	Stop	
<b>Intersection Summary</b>						
Area Type:	Other					
Control Type:	Unsignalized					
Intersection Capacity Utilization	28.2%			ICU Level of Service A		
Analysis Period (min)	15					

Lanes, Volumes, Timings

General Plan 2040 Project Altern. B Conditions

10: US 101 NB Off Ramp/Lakewood Drive & Old Redwood Highway

Timing Plan: A.M. PEAK



Lane Group	EBL	EBT	EBR	WBL	WBT	WBR	NBL	NBT	NBR	SBL	SBT	SBR
Lane Configurations												
Traffic Volume (vph)	264	638	0	0	669	156	224	255	92	255	0	679
Future Volume (vph)	264	638	0	0	669	156	224	255	92	255	0	679
Ideal Flow (vphpl)	1900	1900	1900	1900	1900	1900	1900	1900	1900	1900	1900	1900
Storage Length (ft)	155		0	0		0	270		150	120		0
Storage Lanes	1		0	0		0	1		1	1		1
Taper Length (ft)	50			25			165			75		
Lane Util. Factor	0.97	1.00	1.00	1.00	0.95	0.95	0.91	0.91	0.95	0.97	1.00	1.00
Ped Bike Factor	1.00				1.00			1.00		1.00		
Flt					0.972			0.964				0.850
Flt Protected	0.950						0.950	0.996		0.950		
Satd. Flow (prot)	3433	1863	0	0	3431	0	1610	3244	0	3433	0	1583
Flt Permitted	0.950						0.950	0.996		0.950		
Satd. Flow (perm)	3431	1863	0	0	3431	0	1610	3244	0	3427	0	1583
Right Turn on Red			Yes			Yes			Yes			Yes
Satd. Flow (RTOR)					32			46				247
Link Speed (mph)		35			35			30				30
Link Distance (ft)		226			617			716				478
Travel Time (s)		4.4			12.0			16.3				10.9
Confl. Peds. (#/hr)	1		1	1		1			2	2		
Confl. Bikes (#/hr)			1			1						
Peak Hour Factor	0.85	0.85	0.85	0.83	0.83	0.83	0.90	0.90	0.90	0.89	0.89	0.89
Adj. Flow (vph)	311	751	0	0	806	188	249	283	102	287	0	763
Shared Lane Traffic (%)							15%					
Lane Group Flow (vph)	311	751	0	0	994	0	212	422	0	287	0	763
Enter Blocked Intersection	No	No	No	No	No	No	No	No	No	No	No	No
Lane Alignment	Left	Left	Right	Left	Left	Right	Left	Left	Right	Left	Left	Right
Median Width(ft)		24			24			24				24
Link Offset(ft)		0			0			0				0
Crosswalk Width(ft)		16			16			16				16
Two way Left Turn Lane												
Headway Factor	1.00	1.00	1.00	1.00	1.00	1.00	1.00	1.00	1.00	1.00	1.00	1.00
Turning Speed (mph)	15		9	15		9	15		9	15		9
Number of Detectors	1	2			2		1	2		1		1
Detector Template	Left	Thru			Thru		Left	Thru		Left		Right
Leading Detector (ft)	20	100			100		20	100		20		20
Trailing Detector (ft)	0	0			0		0	0		0		0
Detector 1 Position(ft)	0	0			0		0	0		0		0
Detector 1 Size(ft)	20	6			6		20	6		20		20
Detector 1 Type	Cl+Ex	Cl+Ex			Cl+Ex		Cl+Ex	Cl+Ex		Cl+Ex		Cl+Ex
Detector 1 Channel												
Detector 1 Extend (s)	0.0	0.0			0.0		0.0	0.0		0.0		0.0
Detector 1 Queue (s)	0.0	0.0			0.0		0.0	0.0		0.0		0.0
Detector 1 Delay (s)	0.0	0.0			0.0		0.0	0.0		0.0		0.0
Detector 2 Position(ft)		94			94			94				
Detector 2 Size(ft)		6			6			6				
Detector 2 Type		Cl+Ex			Cl+Ex			Cl+Ex				
Detector 2 Channel												
Detector 2 Extend (s)		0.0			0.0			0.0				

Lanes, Volumes, Timings

General Plan 2040 Project Altern. B Conditions

10: US 101 NB Off Ramp/Lakewood Drive & Old Redwood Highway

Timing Plan: A.M. PEAK



Lane Group	EBL	EBT	EBR	WBL	WBT	WBR	NBL	NBT	NBR	SBL	SBT	SBR
Turn Type	Prot	NA			NA		Split	NA		Prot		pm+ov
Protected Phases	5	2			6		8	8		7		5
Permitted Phases												5 8
Detector Phase	5	2			6		8	8		7		5
Switch Phase												
Minimum Initial (s)	7.0	10.0			10.0		10.0	10.0		7.0		7.0
Minimum Split (s)	11.0	32.1			32.1		33.7	33.7		11.0		11.0
Total Split (s)	13.0	45.3			32.3		33.7	33.7		11.0		13.0
Total Split (%)	14.4%	50.3%			35.9%		37.4%	37.4%		12.2%		14.4%
Maximum Green (s)	9.0	40.2			27.2		29.0	29.0		7.0		9.0
Yellow Time (s)	3.0	4.1			4.1		3.7	3.7		3.0		3.0
All-Red Time (s)	1.0	1.0			1.0		1.0	1.0		1.0		1.0
Lost Time Adjust (s)	0.0	0.0			0.0		0.0	0.0		0.0		0.0
Total Lost Time (s)	4.0	5.1			5.1		4.7	4.7		4.0		4.0
Lead/Lag	Lead				Lag		Lag	Lag		Lead		Lead
Lead-Lag Optimize?	Yes				Yes		Yes	Yes		Yes		Yes
Vehicle Extension (s)	3.0	3.0			3.0		3.0	3.0		3.0		3.0
Recall Mode	None	Max			Max		None	None		None		None
Walk Time (s)		7.0			7.0		7.0	7.0				
Flash Don't Walk (s)		20.0			17.0		22.0	22.0				
Pedestrian Calls (#/hr)		0			0		0	0				
Act Effct Green (s)	9.0	40.4			27.3		17.0	17.0		7.0		30.8
Actuated g/C Ratio	0.11	0.52			0.35		0.22	0.22		0.09		0.39
v/c Ratio	0.79	0.78			0.82		0.61	0.57		0.93		0.99
Control Delay (s/veh)	50.6	24.2			30.3		35.0	27.0		75.7		47.3
Queue Delay	0.0	0.0			0.0		0.0	0.0		0.0		0.0
Total Delay (s/veh)	50.6	24.2			30.3		35.0	27.0		75.7		47.3
LOS	D	C			C		D	C		E		D
Approach Delay (s/veh)		32.0			30.3			29.7				55.0
Approach LOS		C			C			C				E

Intersection Summary

Area Type: Other  
 Cycle Length: 90  
 Actuated Cycle Length: 78.3  
 Natural Cycle: 90  
 Control Type: Actuated-Uncoordinated  
 Maximum v/c Ratio: 0.99  
 Intersection Signal Delay (s/veh): 37.6  
 Intersection LOS: D  
 Intersection Capacity Utilization 88.9%  
 ICU Level of Service E  
 Analysis Period (min) 15

Splits and Phases: 10: US 101 NB Off Ramp/Lakewood Drive & Old Redwood Highway

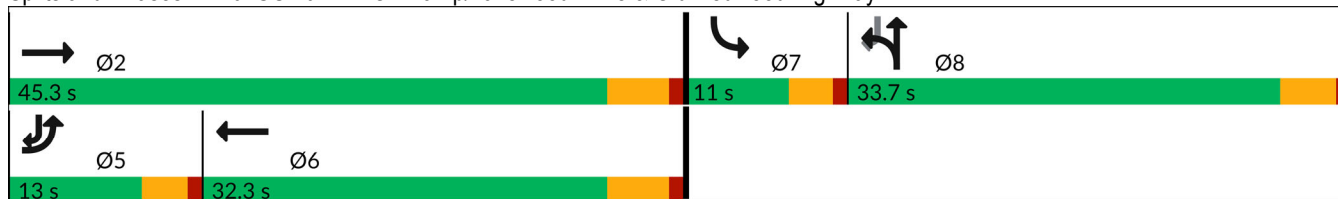



Lanes, Volumes, Timings  
 11: Old Redwood Highway & US 101 NB On Ramp

General Plan 2040 Project Altern. B Conditions

Timing Plan: A.M. PEAK

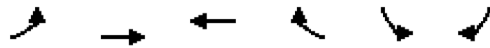

Lane Group	EBL	EBT	WBT	WBR	SBL	SBR
Lane Configurations						
Traffic Volume (vph)	0	902	1301	252	0	0
Future Volume (vph)	0	902	1301	252	0	0
Ideal Flow (vphp)	1900	1900	1900	1900	1900	1900
Storage Length (ft)	245			0	0	0
Storage Lanes	1			0	0	0
Taper Length (ft)	50				25	
Lane Util. Factor	1.00	0.95	0.95	0.95	1.00	1.00
Ped Bike Factor						
Frt			0.976			
Flt Protected						
Satd. Flow (prot)	1863	3539	3454	0	0	0
Flt Permitted						
Satd. Flow (perm)	1863	3539	3454	0	0	0
Link Speed (mph)		35	35		30	
Link Distance (ft)		531	226		299	
Travel Time (s)		10.3	4.4		6.8	
Confl. Peds. (#/hr)	9					
Confl. Bikes (#/hr)				1		
Peak Hour Factor	0.81	0.81	0.89	0.89	0.25	0.25
Adj. Flow (vph)	0	1114	1462	283	0	0
Shared Lane Traffic (%)						
Lane Group Flow (vph)	0	1114	1745	0	0	0
Enter Blocked Intersection	No	No	No	No	No	No
Lane Alignment	Left	Left	Left	Right	Left	Right
Median Width(ft)		12	12		0	
Link Offset(ft)		0	0		0	
Crosswalk Width(ft)		16	16		16	
Two way Left Turn Lane						
Headway Factor	1.00	1.00	1.00	1.00	1.00	1.00
Turning Speed (mph)	15			9	15	9
Sign Control		Free	Free		Free	

Intersection Summary

Area Type:	Other
Control Type:	Unsignalized
Intersection Capacity Utilization	102.7%
Analysis Period (min)	15
	ICU Level of Service G

Lanes, Volumes, Timings

General Plan 2040 Project Altern. B Conditions

12: US 101 SB On Ramp/US 101 SB Off Ramp & Old Redwood Highway

Timing Plan: A.M. PEAK



Lane Group	EBL	EBT	EBR	WBL	WBT	WBR	NBL	NBT	NBR	SBL	SBT	SBR
Lane Configurations		↑↑	↗	↖	↑↑					↖	↔	
Traffic Volume (vph)	0	699	814	559	742	0	0	0	0	185	0	144
Future Volume (vph)	0	699	814	559	742	0	0	0	0	185	0	144
Ideal Flow (vphpl)	1900	1900	1900	1900	1900	1900	1900	1900	1900	1900	1900	1900
Storage Length (ft)	0		0	250		0	0		0	420		0
Storage Lanes	0		1	0		0	0		0	1		0
Taper Length (ft)	25			165			25			75		
Lane Util. Factor	1.00	0.95	1.00	1.00	0.95	1.00	1.00	1.00	1.00	0.95	0.95	1.00
Ped Bike Factor			0.98	1.00								
Frt			0.850								0.867	
Flt Protected				0.950						0.950	0.994	
Satd. Flow (prot)	0	3539	1583	1770	3539	0	0	0	0	1681	1525	0
Flt Permitted				0.950						0.950	0.994	
Satd. Flow (perm)	0	3539	1558	1768	3539	0	0	0	0	1681	1525	0
Right Turn on Red			Yes			Yes			Yes			Yes
Satd. Flow (RTOR)			361								178	
Link Speed (mph)		35			35			30			30	
Link Distance (ft)		423			531			621			831	
Travel Time (s)		8.2			10.3			14.1			18.9	
Confl. Peds. (#/hr)	10		3	3		10						
Confl. Bikes (#/hr)			2									
Peak Hour Factor	0.92	0.92	0.92	0.89	0.89	0.89	0.25	0.25	0.25	0.81	0.81	0.81
Adj. Flow (vph)	0	760	885	628	834	0	0	0	0	228	0	178
Shared Lane Traffic (%)										10%		
Lane Group Flow (vph)	0	760	885	628	834	0	0	0	0	205	201	0
Enter Blocked Intersection	No	No	No	No	No	No	No	No	No	No	No	No
Lane Alignment	Left	Left	Right	Left	Left	Right	Left	Left	Right	Left	Left	Right
Median Width(ft)		24			24			12			12	
Link Offset(ft)		0			0			0			0	
Crosswalk Width(ft)		16			16			16			16	
Two way Left Turn Lane												
Headway Factor	1.00	1.00	1.00	1.00	1.00	1.00	1.00	1.00	1.00	1.00	1.00	1.00
Turning Speed (mph)	15		9	15		9	15		9	15		9
Number of Detectors		2	1	1	2					1	2	
Detector Template		Thru	Right	Left	Thru					Left	Thru	
Leading Detector (ft)		100	20	20	100					20	100	
Trailing Detector (ft)		0	0	0	0					0	0	
Detector 1 Position(ft)		0	0	0	0					0	0	
Detector 1 Size(ft)		6	20	20	6					20	6	
Detector 1 Type		Cl+Ex	Cl+Ex	Cl+Ex	Cl+Ex					Cl+Ex	Cl+Ex	
Detector 1 Channel												
Detector 1 Extend (s)		0.0	0.0	0.0	0.0					0.0	0.0	
Detector 1 Queue (s)		0.0	0.0	0.0	0.0					0.0	0.0	
Detector 1 Delay (s)		0.0	0.0	0.0	0.0					0.0	0.0	
Detector 2 Position(ft)		94			94							94
Detector 2 Size(ft)		6			6							6
Detector 2 Type		Cl+Ex			Cl+Ex							Cl+Ex
Detector 2 Channel												
Detector 2 Extend (s)		0.0			0.0							0.0

Lanes, Volumes, Timings

General Plan 2040 Project Altern. B Conditions

12: US 101 SB On Ramp/US 101 SB Off Ramp & Old Redwood Highway

Timing Plan: A.M. PEAK



Lane Group	EBL	EBT	EBR	WBL	WBT	WBR	NBL	NBT	NBR	SBL	SBT	SBR
Turn Type		NA	Perm	Prot	NA					Perm	NA	
Protected Phases		6		5	2						8	
Permitted Phases			6							8		
Detector Phase		6	6	5	2					8	8	
Switch Phase												
Minimum Initial (s)		10.0	10.0	7.0	10.0					10.0	10.0	
Minimum Split (s)		32.1	32.1	11.0	38.1					14.7	14.7	
Total Split (s)		32.3	32.3	33.0	65.3					14.7	14.7	
Total Split (%)		40.4%	40.4%	41.3%	81.6%					18.4%	18.4%	
Maximum Green (s)		27.2	27.2	29.0	60.2					10.0	10.0	
Yellow Time (s)		4.1	4.1	3.0	4.1					3.7	3.7	
All-Red Time (s)		1.0	1.0	1.0	1.0					1.0	1.0	
Lost Time Adjust (s)		0.0	0.0	0.0	0.0					0.0	0.0	
Total Lost Time (s)		5.1	5.1	4.0	5.1					4.7	4.7	
Lead/Lag		Lag	Lag	Lead								
Lead-Lag Optimize?		Yes	Yes	Yes								
Vehicle Extension (s)		3.0	3.0	3.0	3.0					3.0	3.0	
Recall Mode		Max	Max	None	Max					None	None	
Walk Time (s)		7.0	7.0		7.0							
Flash Don't Walk (s)		20.0	20.0		25.0							
Pedestrian Calls (#/hr)		0	0		0							
Act Effct Green (s)		27.2	27.2	29.0	60.2					10.0	10.0	
Actuated g/C Ratio		0.34	0.34	0.36	0.75					0.13	0.13	
v/c Ratio		0.63	1.15	0.98	0.31					0.98	0.58	
Control Delay (s/veh)		25.1	101.9	58.5	3.6					94.8	15.0	
Queue Delay		0.0	0.0	0.0	0.0					0.0	0.0	
Total Delay (s/veh)		25.1	101.9	58.5	3.6					94.8	15.0	
LOS		C	F	E	A					F	B	
Approach Delay (s/veh)		66.4			27.1						55.3	
Approach LOS		E			C						E	

Intersection Summary

Area Type:	Other
Cycle Length:	80
Actuated Cycle Length:	80
Natural Cycle:	120
Control Type:	Actuated-Uncoordinated
Maximum v/c Ratio:	1.15
Intersection Signal Delay (s/veh):	48.8
Intersection LOS:	D
Intersection Capacity Utilization:	102.7%
ICU Level of Service:	G
Analysis Period (min):	15



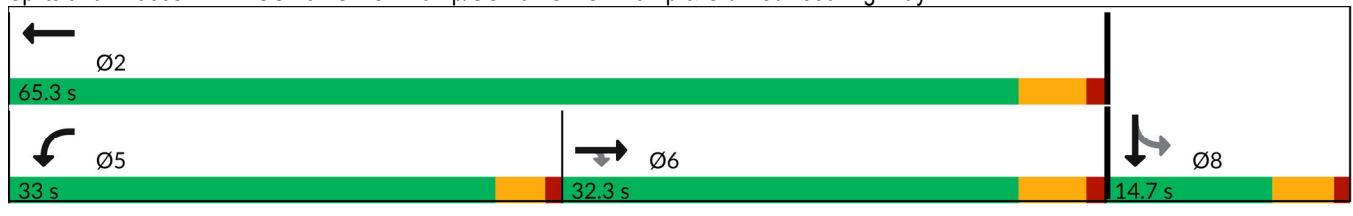



















Splits and Phases: 12: US 101 SB On Ramp/US 101 SB Off Ramp & Old Redwood Highway



Lanes, Volumes, Timings  
1: Old Redwood Hwy & Shiloh Road

General Plan 2040 Project Altern. B Conditions

Timing Plan: P.M. Peak

												
Lane Group	EBL	EBT	EBR	WBL	WBT	WBR	NBL	NBT	NBR	SBL	SBT	SBR
Lane Configurations												
Traffic Volume (vph)	317	398	635	44	393	64	656	565	44	79	545	265
Future Volume (vph)	317	398	635	44	393	64	656	565	44	79	545	265
Ideal Flow (vphpl)	1900	1900	1900	1900	1900	1900	1900	1900	1900	1900	1900	1900
Storage Length (ft)	375		140	0		50	200		98	130		93
Storage Lanes	1		1	0		1	1		1	1		1
Taper Length (ft)	50			25			60			93		
Lane Util. Factor	1.00	1.00	1.00	1.00	1.00	1.00	1.00	1.00	1.00	1.00	1.00	1.00
Ped Bike Factor	1.00					0.98	1.00		0.98			0.97
Frt			0.850			0.850			0.850			0.850
Flt Protected	0.950				0.995		0.950			0.950		
Satd. Flow (prot)	1770	1863	1583	0	1853	1583	1770	1863	1583	1770	1863	1583
Flt Permitted	0.950				0.995		0.950			0.950		
Satd. Flow (perm)	1768	1863	1583	0	1853	1549	1768	1863	1546	1770	1863	1542
Right Turn on Red			Yes			Yes			Yes			Yes
Satd. Flow (RTOR)			363			105			77			105
Link Speed (mph)		40			40			45			40	
Link Distance (ft)		1789			608			748			775	
Travel Time (s)		30.5			10.4			11.3			13.2	
Confl. Peds. (#/hr)	1						1	1				1
Confl. Bikes (#/hr)									3			3
Peak Hour Factor	0.97	0.97	0.97	0.91	0.91	0.91	0.93	0.93	0.93	0.93	0.93	0.93
Adj. Flow (vph)	327	410	655	48	432	70	705	608	47	85	586	285
Shared Lane Traffic (%)												
Lane Group Flow (vph)	327	410	655	0	480	70	705	608	47	85	586	285
Enter Blocked Intersection	No	No	No	No	No	No	No	No	No	No	No	No
Lane Alignment	Left	Left	Right	Left	Left	Right	Left	Left	Right	Left	Left	Right
Median Width(ft)		12			12			12			12	
Link Offset(ft)		0			0			0			0	
Crosswalk Width(ft)		16			16			16			16	
Two way Left Turn Lane												
Headway Factor	1.00	1.00	1.00	1.00	1.00	1.00	1.00	1.00	1.00	1.00	1.00	1.00
Turning Speed (mph)	15		9	15		9	15		9	15		9
Number of Detectors	1	2	1	1	2	1	1	2	1	1	2	1
Detector Template	Left	Thru	Right	Left	Thru	Right	Left	Thru	Right	Left	Thru	Right
Leading Detector (ft)	20	100	20	20	100	20	20	100	20	20	100	20
Trailing Detector (ft)	0	0	0	0	0	0	0	0	0	0	0	0
Detector 1 Position(ft)	0	0	0	0	0	0	0	0	0	0	0	0
Detector 1 Size(ft)	20	6	20	20	6	20	20	6	20	20	6	20
Detector 1 Type	Cl+Ex	Cl+Ex	Cl+Ex	Cl+Ex	Cl+Ex	Cl+Ex	Cl+Ex	Cl+Ex	Cl+Ex	Cl+Ex	Cl+Ex	Cl+Ex
Detector 1 Channel												
Detector 1 Extend (s)	0.0	0.0	0.0	0.0	0.0	0.0	0.0	0.0	0.0	0.0	0.0	0.0
Detector 1 Queue (s)	0.0	0.0	0.0	0.0	0.0	0.0	0.0	0.0	0.0	0.0	0.0	0.0
Detector 1 Delay (s)	0.0	0.0	0.0	0.0	0.0	0.0	0.0	0.0	0.0	0.0	0.0	0.0
Detector 2 Position(ft)		94			94			94			94	
Detector 2 Size(ft)		6			6			6			6	
Detector 2 Type		Cl+Ex			Cl+Ex			Cl+Ex			Cl+Ex	
Detector 2 Channel												
Detector 2 Extend (s)		0.0			0.0			0.0			0.0	

Lanes, Volumes, Timings  
1: Old Redwood Hwy & Shiloh Road

General Plan 2040 Project Altern. B Conditions

Timing Plan: P.M. Peak

Lane Group	EBL	EBT	EBR	WBL	WBT	WBR	NBL	NBT	NBR	SBL	SBT	SBR
Turn Type	Split	NA	Perm	Split	NA	Perm	Prot	NA	Perm	Prot	NA	Perm
Protected Phases	2	2		6	6		3	8		7	4	
Permitted Phases			2			6			8			4
Detector Phase	2	2	2	6	6	6	3	8	8	7	4	4
Switch Phase												
Minimum Initial (s)	5.0	5.0	5.0	5.0	5.0	5.0	5.0	5.0	5.0	5.0	5.0	5.0
Minimum Split (s)	34.5	34.5	34.5	42.5	42.5	42.5	8.5	46.5	46.5	8.5	39.5	39.5
Total Split (s)	35.0	35.0	35.0	42.5	42.5	42.5	18.0	48.0	48.0	9.5	39.5	39.5
Total Split (%)	25.9%	25.9%	25.9%	31.5%	31.5%	31.5%	13.3%	35.6%	35.6%	7.0%	29.3%	29.3%
Maximum Green (s)	30.5	30.5	30.5	38.0	38.0	38.0	14.5	43.5	43.5	6.0	35.0	35.0
Yellow Time (s)	3.5	3.5	3.5	3.5	3.5	3.5	3.0	3.5	3.5	3.0	3.5	3.5
All-Red Time (s)	1.0	1.0	1.0	1.0	1.0	1.0	0.5	1.0	1.0	0.5	1.0	1.0
Lost Time Adjust (s)	0.0	0.0	0.0		0.0	0.0	0.0	0.0	0.0	0.0	0.0	0.0
Total Lost Time (s)	4.5	4.5	4.5		4.5	4.5	3.5	4.5	4.5	3.5	4.5	4.5
Lead/Lag	Lead	Lead	Lead	Lag	Lag	Lag	Lead	Lag	Lag	Lead	Lag	Lag
Lead-Lag Optimize?	Yes	Yes	Yes	Yes	Yes	Yes	Yes	Yes	Yes	Yes	Yes	Yes
Vehicle Extension (s)	3.0	3.0	3.0	3.0	3.0	3.0	3.0	3.0	3.0	3.0	3.0	3.0
Recall Mode	None	None	None	None	None	None	None	None	None	None	None	None
Walk Time (s)	7.0	7.0	7.0	7.0	7.0	7.0		7.0	7.0		7.0	7.0
Flash Don't Walk (s)	23.0	23.0	23.0	31.0	31.0	31.0		35.0	35.0		28.0	28.0
Pedestrian Calls (#/hr)	0	0	0	0	0	0		0	0		0	0
Act Effct Green (s)	30.5	30.5	30.5		36.6	36.6	14.5	43.5	43.5	6.0	35.0	35.0
Actuated g/C Ratio	0.23	0.23	0.23		0.27	0.27	0.11	0.33	0.33	0.04	0.26	0.26
v/c Ratio	0.81	0.96	1.02		0.95	0.14	3.67	1.00	0.08	1.08	1.20	0.59
Control Delay (s/veh)	65.8	87.1	64.0		76.6	2.6	Error	82.2	2.3	182.8	151.0	32.6
Queue Delay	0.0	0.0	0.0		0.0	0.0	0.0	0.0	0.0	0.0	0.0	0.0
Total Delay (s/veh)	65.8	87.1	64.0		76.6	2.6	Error	82.2	2.3	182.8	151.0	32.6
LOS	E	F	E		E	A	F	F	A	F	F	C
Approach Delay (s/veh)		71.2			67.2			675.2			118.6	
Approach LOS		E			E			F			F	

Intersection Summary

Area Type: Other  
 Cycle Length: 135  
 Actuated Cycle Length: 133.6  
 Natural Cycle: 145  
 Control Type: Actuated-Uncoordinated  
 Maximum v/c Ratio: 3.67  
 Intersection Signal Delay (s/veh): 274.2  
 Intersection LOS: F  
 Intersection Capacity Utilization 124.0%  
 ICU Level of Service H  
 Analysis Period (min) 15



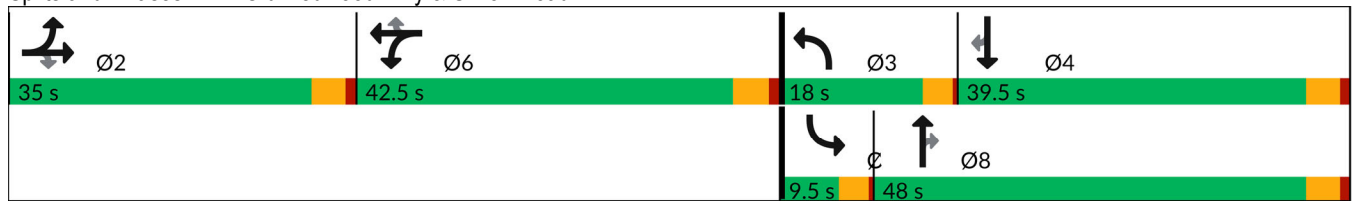

















Splits and Phases: 1: Old Redwood Hwy & Shiloh Road



Lanes, Volumes, Timings  
2: Shiloh Road & Hembree Ln

General Plan 2040 Project Altern. B Conditions

Timing Plan: P.M. Peak

												
Lane Group	EBL	EBT	EBR	WBL	WBT	WBR	NBL	NBT	NBR	SBL	SBT	SBR
Lane Configurations												
Traffic Volume (vph)	661	1147	69	110	1086	118	111	21	128	174	11	526
Future Volume (vph)	661	1147	69	110	1086	118	111	21	128	174	11	526
Ideal Flow (vphpl)	1900	1900	1900	1900	1900	1900	1900	1900	1900	1900	1900	1900
Storage Length (ft)	0		0	100		130	0		0	0		0
Storage Lanes	2		0	1		1	1		0	0		1
Taper Length (ft)	25			50			25			25		
Lane Util. Factor	0.97	1.00	1.00	1.00	0.95	0.95	1.00	1.00	1.00	1.00	1.00	1.00
Ped Bike Factor	1.00				1.00							
Frt		0.992			0.985			0.871				0.850
Flt Protected	0.950			0.950			0.950				0.955	
Satd. Flow (prot)	3433	1848	0	1770	3482	0	1770	1622	0	0	1779	1583
Flt Permitted	0.950			0.950			0.950				0.955	
Satd. Flow (perm)	3432	1848	0	1770	3482	0	1770	1622	0	0	1779	1583
Right Turn on Red			Yes			Yes			Yes			Yes
Satd. Flow (RTOR)		6			17			128				61
Link Speed (mph)		40			40			30				35
Link Distance (ft)		302			1789			216				381
Travel Time (s)		5.1			30.5			4.9				7.4
Confl. Peds. (#/hr)	2						2					
Peak Hour Factor	0.94	0.94	1.00	1.00	0.87	0.87	1.00	1.00	1.00	0.95	1.00	0.95
Adj. Flow (vph)	703	1220	69	110	1248	136	111	21	128	183	11	554
Shared Lane Traffic (%)												
Lane Group Flow (vph)	703	1289	0	110	1384	0	111	149	0	0	194	554
Enter Blocked Intersection	No	No	No	No	No	No	No	No	No	No	No	No
Lane Alignment	Left	Left	Right	Left	Left	Right	Left	Left	Right	Left	Left	Right
Median Width(ft)		24			24			12				12
Link Offset(ft)		0			0			0				0
Crosswalk Width(ft)		16			16			16				16
Two way Left Turn Lane												
Headway Factor	1.00	1.00	1.00	1.00	1.00	1.00	1.00	1.00	1.00	1.00	1.00	1.00
Turning Speed (mph)	15		60	60		9	60		60	15		9
Number of Detectors	1	2		1	2		1	2		1	2	1
Detector Template	Left	Thru		Left	Thru		Left	Thru		Left	Thru	Right
Leading Detector (ft)	20	100		20	100		20	100		20	100	20
Trailing Detector (ft)	0	0		0	0		0	0		0	0	0
Detector 1 Position(ft)	0	0		0	0		0	0		0	0	0
Detector 1 Size(ft)	20	6		20	6		20	6		20	6	20
Detector 1 Type	Cl+Ex	Cl+Ex		Cl+Ex	Cl+Ex		Cl+Ex	Cl+Ex		Cl+Ex	Cl+Ex	Cl+Ex
Detector 1 Channel												
Detector 1 Extend (s)	0.0	0.0		0.0	0.0		0.0	0.0		0.0	0.0	0.0
Detector 1 Queue (s)	0.0	0.0		0.0	0.0		0.0	0.0		0.0	0.0	0.0
Detector 1 Delay (s)	0.0	0.0		0.0	0.0		0.0	0.0		0.0	0.0	0.0
Detector 2 Position(ft)		94			94			94				94
Detector 2 Size(ft)		6			6			6				6
Detector 2 Type		Cl+Ex			Cl+Ex			Cl+Ex				Cl+Ex
Detector 2 Channel												
Detector 2 Extend (s)		0.0			0.0			0.0				0.0
Turn Type	Prot	NA		Prot	NA		Split	NA		Split	NA	pt+ov

Lanes, Volumes, Timings  
2: Shiloh Road & Hembree Ln

General Plan 2040 Project Altern. B Conditions

Timing Plan: P.M. Peak

Lane Group	EBL	EBT	EBR	WBL	WBT	WBR	NBL	NBT	NBR	SBL	SBT	SBR
Protected Phases	5	2		1	6		8	8		4	4	4 5
Permitted Phases												
Detector Phase	5	2		1	6		8	8		4	4	4 5
Switch Phase												
Minimum Initial (s)	3.0	5.0		5.0	5.0		5.0	5.0		5.0	5.0	
Minimum Split (s)	7.5	9.5		9.5	43.5		9.5	9.5		9.5	9.5	
Total Split (s)	21.0	57.0		9.5	45.5		9.5	9.5		14.0	14.0	
Total Split (%)	23.3%	63.3%		10.6%	50.6%		10.6%	10.6%		15.6%	15.6%	
Maximum Green (s)	17.0	53.0		5.5	41.5		5.5	5.5		10.0	10.0	
Yellow Time (s)	3.0	3.0		3.0	3.0		3.0	3.0		3.0	3.0	
All-Red Time (s)	1.0	1.0		1.0	1.0		1.0	1.0		1.0	1.0	
Lost Time Adjust (s)	0.0	0.0		0.0	0.0		0.0	0.0		0.0	0.0	
Total Lost Time (s)	4.0	4.0		4.0	4.0		4.0	4.0		4.0	4.0	
Lead/Lag	Lead	Lag		Lead	Lag							
Lead-Lag Optimize?	Yes	Yes		Yes	Yes							
Vehicle Extension (s)	3.0	3.0		3.0	3.0		3.0	3.0		3.0	3.0	
Recall Mode	None	None		None	None		None	None		None	None	
Walk Time (s)					7.0							
Flash Don't Walk (s)					32.0							
Pedestrian Calls (#/hr)					1							
Act Effct Green (s)	17.0	53.0		5.5	41.5		5.5	5.5		10.0	27.0	
Actuated g/C Ratio	0.19	0.59		0.06	0.46		0.06	0.06		0.11	0.30	
v/c Ratio	1.08	1.18		1.02	0.86		1.03	0.68		0.98	1.07	
Control Delay (s/veh)	96.8	112.9		136.9	28.1		139.2	27.8		103.0	85.5	
Queue Delay	0.0	0.2		0.0	0.0		0.0	0.0		0.0	0.0	
Total Delay (s/veh)	96.8	113.1		136.9	28.1		139.2	27.8		103.0	85.5	
LOS	F	F		F	C		F	C		F	F	
Approach Delay (s/veh)		107.3			36.1			75.4			90.0	
Approach LOS		F			D			E			F	

Intersection Summary

Area Type:	Other
Cycle Length:	90
Actuated Cycle Length:	90
Natural Cycle:	130
Control Type:	Actuated-Uncoordinated
Maximum v/c Ratio:	1.18
Intersection Signal Delay (s/veh):	78.9
Intersection LOS:	E
Intersection Capacity Utilization:	103.2%
ICU Level of Service:	G
Analysis Period (min):	15

Splits and Phases: 2: Shiloh Road & Hembree Ln



Lanes, Volumes, Timings  
3: US 101 NB Off-Ramp & Shiloh Road

General Plan 2040 Project Altern. B Conditions  
Timing Plan: P.M. Peak

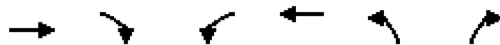

Lane Group	EBT	EBR	WBL	WBT	NBL	NBR
Lane Configurations	↑↑			↑	↘	↗↗
Traffic Volume (vph)	895	0	0	1079	694	939
Future Volume (vph)	895	0	0	1079	694	939
Ideal Flow (vphpl)	1900	1900	1900	1900	1900	1900
Storage Length (ft)		0	0		0	265
Storage Lanes		0	0		1	2
Taper Length (ft)			25		25	
Lane Util. Factor	0.95	1.00	1.00	1.00	1.00	0.88
Frt						0.850
Flt Protected					0.950	
Satd. Flow (prot)	3539	0	0	1863	1770	2787
Flt Permitted					0.950	
Satd. Flow (perm)	3539	0	0	1863	1770	2787
Right Turn on Red		Yes				Yes
Satd. Flow (RTOR)						120
Link Speed (mph)	40			40	30	
Link Distance (ft)	186			371	769	
Travel Time (s)	3.2			6.3	17.5	
Peak Hour Factor	0.94	0.94	0.97	0.97	0.90	0.90
Adj. Flow (vph)	952	0	0	1112	771	1043
Shared Lane Traffic (%)						
Lane Group Flow (vph)	952	0	0	1112	771	1043
Enter Blocked Intersection	No	No	No	No	No	No
Lane Alignment	Left	Right	Left	Left	Left	Right
Median Width(ft)	0			0	12	
Link Offset(ft)	0			0	0	
Crosswalk Width(ft)	16			16	16	
Two way Left Turn Lane						
Headway Factor	1.00	1.00	1.00	1.00	1.00	1.00
Turning Speed (mph)		9	15		15	9
Number of Detectors	2			2	1	1
Detector Template	Thru			Thru	Left	Right
Leading Detector (ft)	100			100	20	20
Trailing Detector (ft)	0			0	0	0
Detector 1 Position(ft)	0			0	0	0
Detector 1 Size(ft)	6			6	20	20
Detector 1 Type	Cl+Ex			Cl+Ex	Cl+Ex	Cl+Ex
Detector 1 Channel						
Detector 1 Extend (s)	0.0			0.0	0.0	0.0
Detector 1 Queue (s)	0.0			0.0	0.0	0.0
Detector 1 Delay (s)	0.0			0.0	0.0	0.0
Detector 2 Position(ft)	94			94		
Detector 2 Size(ft)	6			6		
Detector 2 Type	Cl+Ex			Cl+Ex		
Detector 2 Channel						
Detector 2 Extend (s)	0.0			0.0		
Turn Type	NA			NA	Prot	Perm
Protected Phases	2			6	8	
Permitted Phases						8



Lanes, Volumes, Timings  
 3: US 101 NB Off-Ramp & Shiloh Road

General Plan 2040 Project Altern. B Conditions  
 Timing Plan: P.M. Peak

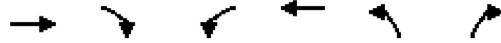

Lane Group	EBT	EBR	WBL	WBT	NBL	NBR
Detector Phase	2			6	8	8
Switch Phase						
Minimum Initial (s)	5.0			5.0	5.0	5.0
Minimum Split (s)	9.0			9.0	9.0	9.0
Total Split (s)	37.0			37.0	35.0	35.0
Total Split (%)	51.4%			51.4%	48.6%	48.6%
Maximum Green (s)	33.0			33.0	31.0	31.0
Yellow Time (s)	3.0			3.0	3.0	3.0
All-Red Time (s)	1.0			1.0	1.0	1.0
Lost Time Adjust (s)	0.0			0.0	0.0	0.0
Total Lost Time (s)	4.0			4.0	4.0	4.0
Lead/Lag						
Lead-Lag Optimize?						
Vehicle Extension (s)	3.0			3.0	3.0	3.0
Recall Mode	None			None	None	None
Act Effect Green (s)	33.0			33.0	31.0	31.0
Actuated g/C Ratio	0.46			0.46	0.43	0.43
v/c Ratio	0.59			1.30	1.01	0.82
Control Delay (s/veh)	16.3			167.5	58.8	22.8
Queue Delay	0.0			0.0	0.0	0.0
Total Delay (s/veh)	16.3			167.5	58.8	22.8
LOS	B			F	E	C
Approach Delay (s/veh)	16.3			167.5	38.1	
Approach LOS	B			F	D	

Intersection Summary

Area Type: Other  
 Cycle Length: 72  
 Actuated Cycle Length: 72  
 Natural Cycle: 110  
 Control Type: Actuated-Uncoordinated  
 Maximum v/c Ratio: 1.30  
 Intersection Signal Delay (s/veh): 69.9  
 Intersection LOS: E  
 Intersection Capacity Utilization 174.3%  
 ICU Level of Service H  
 Analysis Period (min) 15

Splits and Phases: 3: US 101 NB Off-Ramp & Shiloh Road

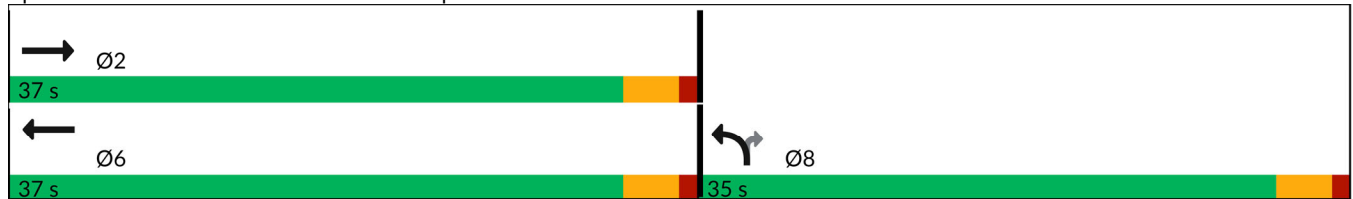

Lanes, Volumes, Timings  
4: Shiloh Road & US 101 SB Off-Ramp

General Plan 2040 Project Altern. B Conditions

Timing Plan: P.M. Peak

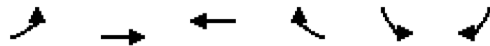

Lane Group	EBL	EBT	WBT	WBR	SBL	SBR
Lane Configurations		↑	↑		↓	↓
Traffic Volume (vph)	0	659	1080	0	434	94
Future Volume (vph)	0	659	1080	0	434	94
Ideal Flow (vphp)	1900	1900	1900	1900	1900	1900
Storage Length (ft)	0			0	0	275
Storage Lanes	0			0	1	1
Taper Length (ft)	25				25	
Lane Util. Factor	1.00	1.00	1.00	1.00	1.00	1.00
Ped Bike Factor						0.98
Frt						0.850
Flt Protected					0.950	
Satd. Flow (prot)	0	1863	1863	0	1770	1583
Flt Permitted					0.950	
Satd. Flow (perm)	0	1863	1863	0	1770	1548
Right Turn on Red				Yes		Yes
Satd. Flow (RTOR)						101
Link Speed (mph)		40	40		30	
Link Distance (ft)		225	306		486	
Travel Time (s)		3.8	5.2		11.0	
Confl. Peds. (#/hr)						1
Peak Hour Factor	0.89	0.89	0.96	0.96	0.93	0.93
Adj. Flow (vph)	0	740	1125	0	467	101
Shared Lane Traffic (%)						
Lane Group Flow (vph)	0	740	1125	0	467	101
Enter Blocked Intersection	No	No	No	No	No	No
Lane Alignment	Left	Left	Left	Right	Left	Right
Median Width(ft)		4	0		12	
Link Offset(ft)		0	0		0	
Crosswalk Width(ft)		16	16		16	
Two way Left Turn Lane						
Headway Factor	1.00	1.00	1.00	1.00	1.00	1.00
Turning Speed (mph)	15			9	15	9
Number of Detectors		2	2		1	1
Detector Template		Thru	Thru		Left	Right
Leading Detector (ft)		100	100		20	20
Trailing Detector (ft)		0	0		0	0
Detector 1 Position(ft)		0	0		0	0
Detector 1 Size(ft)		6	6		20	20
Detector 1 Type		Cl+Ex	Cl+Ex		Cl+Ex	Cl+Ex
Detector 1 Channel						
Detector 1 Extend (s)		0.0	0.0		0.0	0.0
Detector 1 Queue (s)		0.0	0.0		0.0	0.0
Detector 1 Delay (s)		0.0	0.0		0.0	0.0
Detector 2 Position(ft)		94	94			
Detector 2 Size(ft)		6	6			
Detector 2 Type		Cl+Ex	Cl+Ex			
Detector 2 Channel						
Detector 2 Extend (s)		0.0	0.0			
Turn Type		NA	NA		Perm	Perm

Lanes, Volumes, Timings  
4: Shiloh Road & US 101 SB Off-Ramp

General Plan 2040 Project Altern. B Conditions  
Timing Plan: P.M. Peak

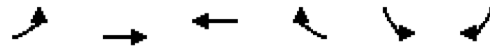

Lane Group	EBL	EBT	WBT	WBR	SBL	SBR
Protected Phases		2	6			
Permitted Phases					4	4
Detector Phase		2	6		4	4
Switch Phase						
Minimum Initial (s)		5.0	5.0		5.0	5.0
Minimum Split (s)		9.0	38.0		9.0	9.0
Total Split (s)		69.0	69.0		21.0	21.0
Total Split (%)		76.7%	76.7%		23.3%	23.3%
Maximum Green (s)		65.0	65.0		17.0	17.0
Yellow Time (s)		3.0	3.0		3.0	3.0
All-Red Time (s)		1.0	1.0		1.0	1.0
Lost Time Adjust (s)		0.0	0.0		0.0	0.0
Total Lost Time (s)		4.0	4.0		4.0	4.0
Lead/Lag						
Lead-Lag Optimize?						
Vehicle Extension (s)		3.0	3.0		3.0	3.0
Recall Mode		None	None		None	None
Walk Time (s)			7.0			
Flash Don't Walk (s)			27.0			
Pedestrian Calls (#/hr)			0			
Act Effct Green (s)		50.7	50.7		17.5	17.5
Actuated g/C Ratio		0.66	0.66		0.23	0.23
v/c Ratio		0.60	0.91		1.15	0.23
Control Delay (s/veh)		9.0	22.7		125.7	8.6
Queue Delay		0.0	0.0		0.0	0.0
Total Delay (s/veh)		9.0	22.7		125.7	8.6
LOS		A	C		F	A
Approach Delay (s/veh)		9.0	22.7		104.9	
Approach LOS		A	C		F	

Intersection Summary

Area Type:	Other
Cycle Length:	90
Actuated Cycle Length:	76.5
Natural Cycle:	90
Control Type:	Actuated-Uncoordinated
Maximum v/c Ratio:	1.15
Intersection Signal Delay (s/veh):	37.7
Intersection LOS:	D
Intersection Capacity Utilization:	170.1%
ICU Level of Service:	H
Analysis Period (min):	15

Splits and Phases: 4: Shiloh Road & US 101 SB Off-Ramp

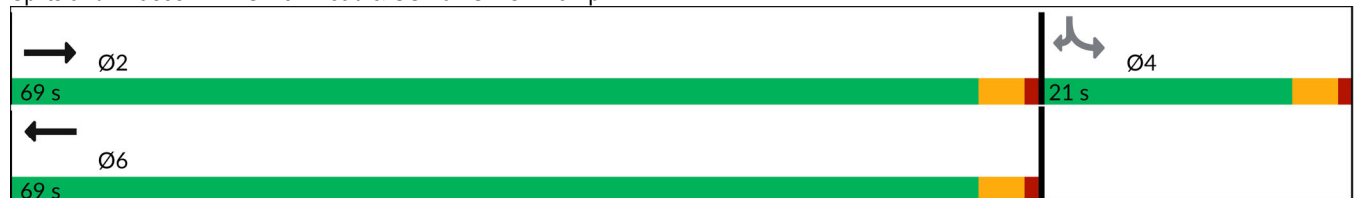

Lanes, Volumes, Timings  
5: Caletti Ave & Shiloh Road

General Plan 2040 Project Altern. B Conditions



















Timing Plan: P.M. Peak

	→	↘	↙	←	↖	↗
Lane Group	EBT	EBR	WBL	WBT	NBL	NBR
Lane Configurations	↑↑		↘	↑	↘	↗
Traffic Volume (vph)	1201	16	105	1139	18	159
Future Volume (vph)	1201	16	105	1139	18	159
Ideal Flow (vphpl)	1900	1900	1900	1900	1900	1900
Storage Length (ft)		0	68		0	0
Storage Lanes		0	1		1	1
Taper Length (ft)			50		25	
Lane Util. Factor	0.95	0.95	1.00	1.00	1.00	1.00
Frt	0.998					0.850
Flt Protected			0.950		0.950	
Satd. Flow (prot)	3532	0	1770	1863	1770	1583
Flt Permitted			0.950		0.950	
Satd. Flow (perm)	3532	0	1770	1863	1770	1583
Link Speed (mph)	40			40	30	
Link Distance (ft)	1081			184	459	
Travel Time (s)	18.4			3.1	10.4	
Peak Hour Factor	0.89	0.89	0.92	0.92	0.89	0.89
Adj. Flow (vph)	1349	18	114	1238	20	179
Shared Lane Traffic (%)						
Lane Group Flow (vph)	1367	0	114	1238	20	179
Enter Blocked Intersection	No	No	No	No	No	No
Lane Alignment	Left	Right	Left	Left	Left	Right
Median Width(ft)	12			12	12	
Link Offset(ft)	0			0	0	
Crosswalk Width(ft)	16			16	16	
Two way Left Turn Lane						
Headway Factor	1.00	1.00	1.00	1.00	1.00	1.00
Turning Speed (mph)		9	15		15	9
Sign Control	Free			Free	Stop	
<b>Intersection Summary</b>						
Area Type:	Other					
Control Type:	Unsignalized					
Intersection Capacity Utilization	69.9%			ICU Level of Service C		
Analysis Period (min)	15					

Lanes, Volumes, Timings  
6: Conde Lane & Shiloh Road

General Plan 2040 Project Altern. B Conditions

Timing Plan: P.M. Peak

												
Lane Group	EBL	EBT	EBR	WBL	WBT	WBR	NBL	NBT	NBR	SBL	SBT	SBR
Lane Configurations												
Traffic Volume (vph)	77	724	0	9	743	372	4	2	16	387	4	65
Future Volume (vph)	77	724	0	9	743	372	4	2	16	387	4	65
Ideal Flow (vphpl)	1900	1900	1900	1900	1900	1900	1900	1900	1900	1900	1900	1900
Storage Length (ft)	90		0	127		0	0		0	0		40
Storage Lanes	1		0	1		0	0		0	0		1
Taper Length (ft)	70			40			25			25		
Lane Util. Factor	1.00	0.95	0.95	1.00	0.95	0.95	1.00	1.00	1.00	1.00	1.00	1.00
Ped Bike Factor	1.00				0.99							
Frt					0.950			0.901				0.850
Flt Protected	0.950			0.950				0.991			0.953	
Satd. Flow (prot)	1770	3539	0	1770	3338	0	0	1663	0	0	1775	1583
Flt Permitted	0.950			0.950				0.991			0.953	
Satd. Flow (perm)	1768	3539	0	1770	3338	0	0	1663	0	0	1775	1583
Right Turn on Red			Yes			Yes			Yes			No
Satd. Flow (RTOR)					90			25				
Link Speed (mph)		40			40			30				35
Link Distance (ft)		815			1081			418				522
Travel Time (s)		13.9			18.4			9.5				10.2
Confl. Peds. (#/hr)	1						1					
Peak Hour Factor	0.88	0.88	0.88	0.80	0.80	0.80	0.63	0.63	0.63	0.88	0.88	0.88
Adj. Flow (vph)	88	823	0	11	929	465	6	3	25	440	5	74
Shared Lane Traffic (%)												
Lane Group Flow (vph)	88	823	0	11	1394	0	0	34	0	0	445	74
Enter Blocked Intersection	No	No	No	No	No	No	No	No	No	No	No	No
Lane Alignment	Left	Left	Right	Left	Left	Right	Left	Left	Right	Left	Left	Right
Median Width(ft)		12			12			0				0
Link Offset(ft)		0			0			0				0
Crosswalk Width(ft)		16			16			16				16
Two way Left Turn Lane												
Headway Factor	1.00	1.00	1.00	1.00	1.00	1.00	1.00	1.00	1.00	1.00	1.00	1.00
Turning Speed (mph)	15		9	15		9	15		9	15		9
Number of Detectors	1	2		1	2		1	2		1	1	1
Detector Template	Left	Thru		Left	Thru		Left	Thru		Left	Thru	Right
Leading Detector (ft)	20	100		20	100		20	100		20	30	20
Trailing Detector (ft)	0	0		0	0		0	0		0	0	0
Detector 1 Position(ft)	0	0		0	0		0	0		0	0	0
Detector 1 Size(ft)	20	6		20	6		20	6		20	30	20
Detector 1 Type	Cl+Ex	Cl+Ex		Cl+Ex	Cl+Ex		Cl+Ex	Cl+Ex		Cl+Ex	Cl+Ex	Cl+Ex
Detector 1 Channel												
Detector 1 Extend (s)	0.0	0.0		0.0	0.0		0.0	0.0		0.0	0.0	0.0
Detector 1 Queue (s)	0.0	0.0		0.0	0.0		0.0	0.0		0.0	0.0	0.0
Detector 1 Delay (s)	0.0	0.0		0.0	0.0		0.0	0.0		0.0	0.0	0.0
Detector 2 Position(ft)		94			94			94				
Detector 2 Size(ft)		6			6			6				
Detector 2 Type		Cl+Ex			Cl+Ex			Cl+Ex				
Detector 2 Channel												
Detector 2 Extend (s)		0.0			0.0			0.0				
Turn Type	Prot	NA		Prot	NA		Split	NA		Split	NA	custom

Lanes, Volumes, Timings  
6: Conde Lane & Shiloh Road

General Plan 2040 Project Altern. B Conditions

Timing Plan: P.M. Peak

Lane Group	EBL	EBT	EBR	WBL	WBT	WBR	NBL	NBT	NBR	SBL	SBT	SBR
Protected Phases	5	2		1	6		7	7		4	4	
Permitted Phases												6
Detector Phase	5	2		1	6		7	7		4	4	6
Switch Phase												
Minimum Initial (s)	8.0	8.0		8.0	8.0		10.0	10.0		11.0	11.0	8.0
Minimum Split (s)	12.0	46.0		12.0	12.0		37.0	37.0		15.0	15.0	12.0
Total Split (s)	13.0	46.0		12.0	45.0		37.0	37.0		15.0	15.0	45.0
Total Split (%)	11.8%	41.8%		10.9%	40.9%		33.6%	33.6%		13.6%	13.6%	40.9%
Maximum Green (s)	9.0	42.0		8.0	41.0		33.0	33.0		11.0	11.0	41.0
Yellow Time (s)	3.0	3.0		3.0	3.0		3.0	3.0		3.0	3.0	3.0
All-Red Time (s)	1.0	1.0		1.0	1.0		1.0	1.0		1.0	1.0	1.0
Lost Time Adjust (s)	0.0	0.0		0.0	0.0		0.0	0.0		0.0	0.0	0.0
Total Lost Time (s)	4.0	4.0		4.0	4.0		4.0	4.0		4.0	4.0	4.0
Lead/Lag	Lead	Lag		Lead	Lag							Lag
Lead-Lag Optimize?	Yes	Yes		Yes	Yes							Yes
Vehicle Extension (s)	3.0	3.0		3.0	3.0		3.0	3.0		3.0	3.0	3.0
Recall Mode	None	None		None	None		None	None		None	None	None
Walk Time (s)		7.0					7.0	7.0				
Flash Don't Walk (s)		35.0					26.0	26.0				
Pedestrian Calls (#/hr)		0					0	0				
Act Effct Green (s)	8.7	49.4		8.2	41.9		10.2			11.2	41.9	
Actuated g/C Ratio	0.11	0.63		0.10	0.53		0.13			0.14	0.53	
v/c Ratio	0.45	0.37		0.06	0.77		0.14			1.75	0.09	
Control Delay (s/veh)	44.0	9.4		37.1	19.6		19.5			381.4	12.6	
Queue Delay	0.0	0.0		0.0	0.0		0.0			0.0	0.0	
Total Delay (s/veh)	44.0	9.4		37.1	19.6		19.5			381.4	12.6	
LOS	D	A		D	B		B			F	B	
Approach Delay (s/veh)		12.7			19.7		19.5			328.8		
Approach LOS		B			B		B			F		

Intersection Summary

Area Type:	Other
Cycle Length:	110
Actuated Cycle Length:	78.6
Natural Cycle:	150
Control Type:	Actuated-Uncoordinated
Maximum v/c Ratio:	1.75
Intersection Signal Delay (s/veh):	73.4
Intersection LOS:	E
Intersection Capacity Utilization:	77.5%
ICU Level of Service:	D
Analysis Period (min):	15

Splits and Phases: 6: Conde Lane & Shiloh Road



Lanes, Volumes, Timings  
7: Driveway 1/Gridley Drive & Shiloh Road

General Plan 2040 Project Altern. B Conditions

Timing Plan: P.M. Peak





















Lane Group	EBL	EBT	EBR	WBL	WBT	WBR	NBL	NBT	NBR	SBL	SBT	SBR
Lane Configurations												
Traffic Volume (vph)	25	385	76	0	401	0	71	0	0	0	0	21
Future Volume (vph)	25	385	76	0	401	0	71	0	0	0	0	21
Ideal Flow (vphp)	1900	1900	1900	1900	1900	1900	1900	1900	1900	1900	1900	1900
Storage Length (ft)	0		150	0		0	0		0	0		0
Storage Lanes	0		1	0		0	1		0	0		0
Taper Length (ft)	25			25			25			25		
Lane Util. Factor	1.00	1.00	1.00	1.00	1.00	1.00	1.00	1.00	1.00	1.00	1.00	1.00
Ped Bike Factor												
Frt			0.850								0.865	
Flt Protected		0.997					0.950					
Satd. Flow (prot)	0	1857	1583	0	1863	0	1770	1863	0	0	1611	0
Flt Permitted		0.997					0.950					
Satd. Flow (perm)	0	1857	1583	0	1863	0	1770	1863	0	0	1611	0
Link Speed (mph)		40			40			30			30	
Link Distance (ft)		608			2146			248			715	
Travel Time (s)		10.4			36.6			5.6			16.3	
Confl. Peds. (#/hr)	1											
Confl. Bikes (#/hr)			1									
Peak Hour Factor	0.94	0.94	0.94	0.69	0.69	0.69	1.00	1.00	1.00	0.58	0.58	0.58
Adj. Flow (vph)	27	410	81	0	581	0	71	0	0	0	0	36
Shared Lane Traffic (%)												
Lane Group Flow (vph)	0	437	81	0	581	0	71	0	0	0	36	0
Enter Blocked Intersection	No	No	No	No	No	No	No	No	No	No	No	No
Lane Alignment	Left	Left	Right	Left	Left	Right	Left	Left	Right	Left	Left	Right
Median Width(ft)		0			0			12			12	
Link Offset(ft)		0			0			0			0	
Crosswalk Width(ft)		16			16			16			16	
Two way Left Turn Lane												
Headway Factor	1.00	1.00	1.00	1.00	1.00	1.00	1.00	1.00	1.00	1.00	1.00	1.00
Turning Speed (mph)	15		9	15		9	15		9	15		9
Sign Control		Free			Free			Stop			Stop	

Intersection Summary	
Area Type:	Other
Control Type:	Unsignalized
Intersection Capacity Utilization	58.0%
Analysis Period (min)	15
	ICU Level of Service B

Lanes, Volumes, Timings  
8: Old Redwood Hwy & Driveway 2

General Plan 2040 Project Altern. B Conditions

Timing Plan: P.M. Peak

												
Lane Group	EBL	EBT	EBR	WBL	WBT	WBR	NBL	NBT	NBR	SBL	SBT	SBR
Lane Configurations												
Traffic Volume (vph)	4	0	0	41	0	66	0	1195	45	72	1152	0
Future Volume (vph)	4	0	0	41	0	66	0	1195	45	72	1152	0
Ideal Flow (vphp)	1900	1900	1900	1900	1900	1900	1900	1900	1900	1900	1900	1900
Storage Length (ft)	0		0	0		0	0		100	50		0
Storage Lanes	0		0	1		0	0		1	1		0
Taper Length (ft)	25			25			25			25		
Lane Util. Factor	1.00	1.00	1.00	1.00	1.00	1.00	1.00	1.00	1.00	1.00	1.00	1.00
Ped Bike Factor												
Frt					0.850				0.850			
Flt Protected		0.950		0.950						0.950		
Satd. Flow (prot)	0	1770	0	1770	1583	0	0	1863	1583	1770	1863	0
Flt Permitted		0.950		0.950						0.950		
Satd. Flow (perm)	0	1770	0	1770	1583	0	0	1863	1583	1770	1863	0
Link Speed (mph)		30			30			45			45	
Link Distance (ft)		98			385			520			748	
Travel Time (s)		2.2			8.8			7.9			11.3	
Confl. Bikes (#/hr)									3			5
Peak Hour Factor	0.38	0.38	0.38	1.00	1.00	1.00	0.91	0.91	0.91	0.94	0.94	0.94
Adj. Flow (vph)	11	0	0	41	0	66	0	1313	49	77	1226	0
Shared Lane Traffic (%)												
Lane Group Flow (vph)	0	11	0	41	66	0	0	1313	49	77	1226	0
Enter Blocked Intersection	No	No	No	No	No	No	No	No	No	No	No	No
Lane Alignment	Left	Left	Right	Left	Left	Right	Left	Left	Right	Left	Left	Right
Median Width(ft)		12			12			12			12	
Link Offset(ft)		0			0			0			0	
Crosswalk Width(ft)		16			16			16			16	
Two way Left Turn Lane												
Headway Factor	1.00	1.00	1.00	1.00	1.00	1.00	1.00	1.00	1.00	1.00	1.00	1.00
Turning Speed (mph)	15		9	15		9	15		9	15		9
Sign Control		Stop			Stop			Free			Free	
<b>Intersection Summary</b>												
Area Type:	Other											
Control Type:	Unsignalized											
Intersection Capacity Utilization	77.3%						ICU Level of Service D					
Analysis Period (min)	15											



Lanes, Volumes, Timings  
9: Driveway 3 & Shiloh Road

General Plan 2040 Project Altern. B Conditions

Timing Plan: P.M. Peak

	→	↘	↙	←	↖	↗
Lane Group	EBT	EBR	WBL	WBT	NBL	NBR
Lane Configurations	↑	↗		↖	↖	↗
Traffic Volume (vph)	120	233	22	164	216	21
Future Volume (vph)	120	233	22	164	216	21
Ideal Flow (vphpl)	1900	1900	1900	1900	1900	1900
Storage Length (ft)		200	0		0	0
Storage Lanes		1	0		1	1
Taper Length (ft)			25		25	
Lane Util. Factor	1.00	1.00	1.00	1.00	1.00	1.00
Frt		0.850				0.850
Flt Protected				0.994	0.950	
Satd. Flow (prot)	1863	1583	0	1852	1770	1583
Flt Permitted				0.994	0.950	
Satd. Flow (perm)	1863	1583	0	1852	1770	1583
Link Speed (mph)	40			40	30	
Link Distance (ft)	2146			134	402	
Travel Time (s)	36.6			2.3	9.1	
Peak Hour Factor	0.92	0.92	0.68	0.68	1.00	1.00
Adj. Flow (vph)	130	253	32	241	216	21
Shared Lane Traffic (%)						
Lane Group Flow (vph)	130	253	0	273	216	21
Enter Blocked Intersection	No	No	No	No	No	No
Lane Alignment	Left	Right	Left	Left	Left	Right
Median Width(ft)	0			0	12	
Link Offset(ft)	0			0	0	
Crosswalk Width(ft)	16			16	16	
Two way Left Turn Lane						
Headway Factor	1.00	1.00	1.00	1.00	1.00	1.00
Turning Speed (mph)		9	15		15	9
Sign Control	Free			Free	Stop	
<b>Intersection Summary</b>						
Area Type:	Other					
Control Type:	Unsignalized					
Intersection Capacity Utilization	35.1%			ICU Level of Service A		
Analysis Period (min)	15					

Lanes, Volumes, Timings

General Plan 2040 Project Altern. B Conditions

10: US 101 NB Off Ramp/Lakewood Drive & Old Redwood Highway

Timing Plan: P.M. Peak



Lane Group	EBL	EBT	EBR	WBL	WBT	WBR	NBL	NBT	NBR	SBL	SBT	SBR
Lane Configurations												
Traffic Volume (vph)	309	717	0	0	756	270	528	539	303	386	0	618
Future Volume (vph)	309	717	0	0	756	270	528	539	303	386	0	618
Ideal Flow (vphpl)	1900	1900	1900	1900	1900	1900	1900	1900	1900	1900	1900	1900
Storage Length (ft)	155		0	0		0	270		150	120		0
Storage Lanes	1		0	0		0	1		1	1		1
Taper Length (ft)	50			25			165			75		
Lane Util. Factor	0.97	1.00	1.00	1.00	0.95	0.95	0.91	0.91	0.95	0.97	1.00	1.00
Ped Bike Factor	1.00				0.99			0.99		1.00		
Fr <sub>t</sub>					0.961			0.950				0.850
Fl <sub>t</sub> Protected	0.950						0.950	0.996		0.950		
Satd. Flow (prot)	3433	1863	0	0	3382	0	1610	3187	0	3433	0	1583
Fl <sub>t</sub> Permitted	0.950						0.950	0.996		0.950		
Satd. Flow (perm)	3429	1863	0	0	3382	0	1610	3187	0	3422	0	1583
Right Turn on Red			Yes			Yes			Yes			Yes
Satd. Flow (RTOR)					57			79				244
Link Speed (mph)		35			35			30				30
Link Distance (ft)		226			617			716				478
Travel Time (s)		4.4			12.0			16.3				10.9
Confl. Peds. (#/hr)	3		1	1		3			8	8		
Confl. Bikes (#/hr)			2			9						
Peak Hour Factor	0.87	0.87	0.87	0.91	0.91	0.91	0.92	0.92	0.92	0.96	0.96	0.96
Adj. Flow (vph)	355	824	0	0	831	297	574	586	329	402	0	644
Shared Lane Traffic (%)							13%					
Lane Group Flow (vph)	355	824	0	0	1128	0	499	990	0	402	0	644
Enter Blocked Intersection	No	No	No	No	No	No	No	No	No	No	No	No
Lane Alignment	Left	Left	Right	Left	Left	Right	Left	Left	Right	Left	Left	Right
Median Width(ft)		24			24			24				24
Link Offset(ft)		0			0			0				0
Crosswalk Width(ft)		16			16			16				16
Two way Left Turn Lane												
Headway Factor	1.00	1.00	1.00	1.00	1.00	1.00	1.00	1.00	1.00	1.00	1.00	1.00
Turning Speed (mph)	15		9	15		9	15		9	15		9
Number of Detectors	1	2			2		1	2		1		1
Detector Template	Left	Thru			Thru		Left	Thru		Left		Right
Leading Detector (ft)	20	100			100		20	100		20		20
Trailing Detector (ft)	0	0			0		0	0		0		0
Detector 1 Position(ft)	0	0			0		0	0		0		0
Detector 1 Size(ft)	20	6			6		20	6		20		20
Detector 1 Type	Cl+Ex	Cl+Ex			Cl+Ex		Cl+Ex	Cl+Ex		Cl+Ex		Cl+Ex
Detector 1 Channel												
Detector 1 Extend (s)	0.0	0.0			0.0		0.0	0.0		0.0		0.0
Detector 1 Queue (s)	0.0	0.0			0.0		0.0	0.0		0.0		0.0
Detector 1 Delay (s)	0.0	0.0			0.0		0.0	0.0		0.0		0.0
Detector 2 Position(ft)		94			94			94				
Detector 2 Size(ft)		6			6			6				
Detector 2 Type		Cl+Ex			Cl+Ex			Cl+Ex				
Detector 2 Channel												
Detector 2 Extend (s)		0.0			0.0			0.0				

Lanes, Volumes, Timings

General Plan 2040 Project Altern. B Conditions

10: US 101 NB Off Ramp/Lakewood Drive & Old Redwood Highway

Timing Plan: P.M. Peak



Lane Group	EBL	EBT	EBR	WBL	WBT	WBR	NBL	NBT	NBR	SBL	SBT	SBR
Turn Type	Prot	NA			NA		Split	NA		Prot		pm+ov
Protected Phases	5	2			6		8	8		7		5
Permitted Phases												5 8
Detector Phase	5	2			6		8	8		7		5
Switch Phase												
Minimum Initial (s)	7.0	10.0			10.0		10.0	10.0		7.0		7.0
Minimum Split (s)	11.0	32.1			32.1		33.7	33.7		11.0		11.0
Total Split (s)	13.0	45.3			32.3		33.7	33.7		11.0		13.0
Total Split (%)	14.4%	50.3%			35.9%		37.4%	37.4%		12.2%		14.4%
Maximum Green (s)	9.0	40.2			27.2		29.0	29.0		7.0		9.0
Yellow Time (s)	3.0	4.1			4.1		3.7	3.7		3.0		3.0
All-Red Time (s)	1.0	1.0			1.0		1.0	1.0		1.0		1.0
Lost Time Adjust (s)	0.0	0.0			0.0		0.0	0.0		0.0		0.0
Total Lost Time (s)	4.0	5.1			5.1		4.7	4.7		4.0		4.0
Lead/Lag	Lead				Lag		Lag	Lag		Lead		Lead
Lead-Lag Optimize?	Yes				Yes		Yes	Yes		Yes		Yes
Vehicle Extension (s)	3.0	3.0			3.0		3.0	3.0		3.0		3.0
Recall Mode	None	Max			Max		None	None		None		None
Walk Time (s)		7.0			7.0		7.0	7.0				
Flash Don't Walk (s)		20.0			17.0		22.0	22.0				
Pedestrian Calls (#/hr)		0			0		0	0				
Act Effct Green (s)	9.0	40.2			27.2		29.0	29.0		7.0		42.7
Actuated g/C Ratio	0.10	0.45			0.30		0.32	0.32		0.08		0.47
v/c Ratio	1.03	0.99			1.06		0.96	0.92		1.51		0.73
Control Delay (s/veh)	99.4	55.4			76.4		63.3	41.4		277.9		17.2
Queue Delay	0.0	0.0			0.0		0.0	0.0		0.0		0.0
Total Delay (s/veh)	99.4	55.4			76.4		63.3	41.4		277.9		17.2
LOS	F	E			E		E	D		F		B
Approach Delay (s/veh)		68.6			76.4			48.7				117.4
Approach LOS		E			E			D				F

Intersection Summary

Area Type: Other  
 Cycle Length: 90  
 Actuated Cycle Length: 90  
 Natural Cycle: 110  
 Control Type: Actuated-Uncoordinated  
 Maximum v/c Ratio: 1.51  
 Intersection Signal Delay (s/veh): 74.9  
 Intersection LOS: E  
 Intersection Capacity Utilization 106.2%  
 ICU Level of Service G  
 Analysis Period (min) 15

Splits and Phases: 10: US 101 NB Off Ramp/Lakewood Drive & Old Redwood Highway

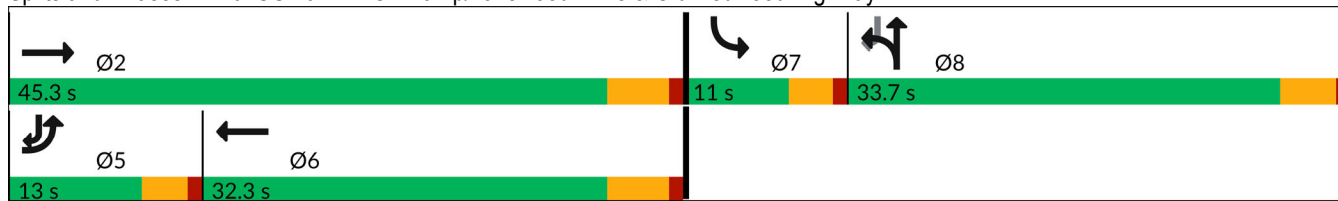

Lanes, Volumes, Timings  
 11: Old Redwood Highway & US 101 NB On Ramp

General Plan 2040 Project Altern. B Conditions

Timing Plan: P.M. Peak

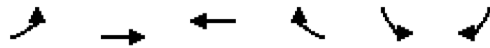

Lane Group	EBL	EBT	WBT	WBR	SBL	SBR
Lane Configurations						
Traffic Volume (vph)	0	1026	1564	297	0	0
Future Volume (vph)	0	1026	1564	297	0	0
Ideal Flow (vphpl)	1900	1900	1900	1900	1900	1900
Storage Length (ft)	245			0	0	0
Storage Lanes	1			0	0	0
Taper Length (ft)	50				25	
Lane Util. Factor	1.00	0.95	0.95	0.95	1.00	1.00
Ped Bike Factor						
Frt			0.976			
Flt Protected						
Satd. Flow (prot)	1863	3539	3454	0	0	0
Flt Permitted						
Satd. Flow (perm)	1863	3539	3454	0	0	0
Link Speed (mph)		35	35		30	
Link Distance (ft)		531	226		299	
Travel Time (s)		10.3	4.4		6.8	
Confl. Peds. (#/hr)	17			17		
Confl. Bikes (#/hr)				8		
Peak Hour Factor	0.85	0.85	0.91	0.91	0.25	0.25
Adj. Flow (vph)	0	1207	1719	326	0	0
Shared Lane Traffic (%)						
Lane Group Flow (vph)	0	1207	2045	0	0	0
Enter Blocked Intersection	No	No	No	No	No	No
Lane Alignment	Left	Left	Left	Right	Left	Right
Median Width(ft)		12	12		0	
Link Offset(ft)		0	0		0	
Crosswalk Width(ft)		16	16		16	
Two way Left Turn Lane						
Headway Factor	1.00	1.00	1.00	1.00	1.00	1.00
Turning Speed (mph)	15			9	15	9
Sign Control		Free	Free		Free	

Intersection Summary

Area Type:	Other
Control Type:	Unsignalized
Intersection Capacity Utilization	83.7%
Analysis Period (min)	15
	ICU Level of Service E

Lanes, Volumes, Timings

General Plan 2040 Project Altern. B Conditions

12: US 101 SB On Ramp/US 101 SB Off Ramp & Old Redwood Highway

Timing Plan: P.M. Peak



Lane Group	EBL	EBT	EBR	WBL	WBT	WBR	NBL	NBT	NBR	SBL	SBT	SBR
Lane Configurations		↑↑	↗	↖	↑↑					↖	↔	
Traffic Volume (vph)	0	612	501	443	1121	0	0	0	0	346	2	221
Future Volume (vph)	0	612	501	443	1121	0	0	0	0	346	2	221
Ideal Flow (vphpl)	1900	1900	1900	1900	1900	1900	1900	1900	1900	1900	1900	1900
Storage Length (ft)	0		0	250		0	0		0	420		0
Storage Lanes	0		1	0		0	0		0	1		0
Taper Length (ft)	25			165			25			75		
Lane Util. Factor	1.00	0.95	1.00	1.00	0.95	1.00	1.00	1.00	1.00	0.95	0.95	1.00
Ped Bike Factor			0.98	1.00								
Frt			0.850									0.878
Flt Protected				0.950						0.950	0.991	
Satd. Flow (prot)	0	3539	1583	1770	3539	0	0	0	0	1681	1540	0
Flt Permitted				0.950						0.950	0.991	
Satd. Flow (perm)	0	3539	1558	1768	3539	0	0	0	0	1681	1540	0
Right Turn on Red			Yes			Yes			Yes			Yes
Satd. Flow (RTOR)			443									98
Link Speed (mph)		35			35			30				30
Link Distance (ft)		423			531			621				831
Travel Time (s)		8.2			10.3			14.1				18.9
Confl. Peds. (#/hr)	19		2	2		18						
Confl. Bikes (#/hr)			4			2						
Peak Hour Factor	0.94	0.94	0.94	0.89	0.89	0.89	0.25	0.25	0.25	0.83	0.83	0.83
Adj. Flow (vph)	0	651	533	498	1260	0	0	0	0	417	2	266
Shared Lane Traffic (%)										14%		
Lane Group Flow (vph)	0	651	533	498	1260	0	0	0	0	359	326	0
Enter Blocked Intersection	No	No	No	No	No	No	No	No	No	No	No	No
Lane Alignment	Left	Left	Right	Left	Left	Right	Left	Left	Right	Left	Left	Right
Median Width(ft)		24			24			12				12
Link Offset(ft)		0			0			0				0
Crosswalk Width(ft)		16			16			16				16
Two way Left Turn Lane												
Headway Factor	1.00	1.00	1.00	1.00	1.00	1.00	1.00	1.00	1.00	1.00	1.00	1.00
Turning Speed (mph)	15		9	15		9	15		9	15		9
Number of Detectors		2	1	1	2					1	2	
Detector Template		Thru	Right	Left	Thru					Left	Thru	
Leading Detector (ft)		100	20	20	100					20	100	
Trailing Detector (ft)		0	0	0	0					0	0	
Detector 1 Position(ft)		0	0	0	0					0	0	
Detector 1 Size(ft)		6	20	20	6					20	6	
Detector 1 Type		Cl+Ex	Cl+Ex	Cl+Ex	Cl+Ex					Cl+Ex	Cl+Ex	
Detector 1 Channel												
Detector 1 Extend (s)		0.0	0.0	0.0	0.0					0.0	0.0	
Detector 1 Queue (s)		0.0	0.0	0.0	0.0					0.0	0.0	
Detector 1 Delay (s)		0.0	0.0	0.0	0.0					0.0	0.0	
Detector 2 Position(ft)		94			94							94
Detector 2 Size(ft)		6			6							6
Detector 2 Type		Cl+Ex			Cl+Ex							Cl+Ex
Detector 2 Channel												
Detector 2 Extend (s)		0.0			0.0							0.0

Lanes, Volumes, Timings

General Plan 2040 Project Altern. B Conditions

12: US 101 SB On Ramp/US 101 SB Off Ramp & Old Redwood Highway

Timing Plan: P.M. Peak



Lane Group	EBL	EBT	EBR	WBL	WBT	WBR	NBL	NBT	NBR	SBL	SBT	SBR
Turn Type		NA	Perm	Prot	NA					Perm	NA	
Protected Phases		6		5	2						8	
Permitted Phases			6							8		
Detector Phase		6	6	5	2					8	8	
Switch Phase												
Minimum Initial (s)		10.0	10.0	7.0	10.0					10.0	10.0	
Minimum Split (s)		32.1	32.1	11.0	38.1					14.7	14.7	
Total Split (s)		33.0	33.0	22.0	55.0					15.0	15.0	
Total Split (%)		47.1%	47.1%	31.4%	78.6%					21.4%	21.4%	
Maximum Green (s)		27.9	27.9	18.0	49.9					10.3	10.3	
Yellow Time (s)		4.1	4.1	3.0	4.1					3.7	3.7	
All-Red Time (s)		1.0	1.0	1.0	1.0					1.0	1.0	
Lost Time Adjust (s)		0.0	0.0	0.0	0.0					0.0	0.0	
Total Lost Time (s)		5.1	5.1	4.0	5.1					4.7	4.7	
Lead/Lag		Lag	Lag	Lead								
Lead-Lag Optimize?		Yes	Yes	Yes								
Vehicle Extension (s)		3.0	3.0	3.0	3.0					3.0	3.0	
Recall Mode		Max	Max	None	Max					None	None	
Walk Time (s)		7.0	7.0		7.0							
Flash Don't Walk (s)		20.0	20.0		25.0							
Pedestrian Calls (#/hr)		0	0		0							
Act Effct Green (s)		27.9	27.9	18.0	49.9					10.3	10.3	
Actuated g/C Ratio		0.40	0.40	0.26	0.71					0.15	0.15	
v/c Ratio		0.46	0.60	1.09	0.50					1.45	1.05	
Control Delay (s/veh)		16.8	6.4	98.8	5.3					252.8	89.9	
Queue Delay		0.0	0.0	0.0	0.0					0.0	0.0	
Total Delay (s/veh)		16.8	6.4	98.8	5.3					252.8	89.9	
LOS		B	A	F	A					F	F	
Approach Delay (s/veh)		12.2			31.8						175.3	
Approach LOS		B			C						F	

Intersection Summary





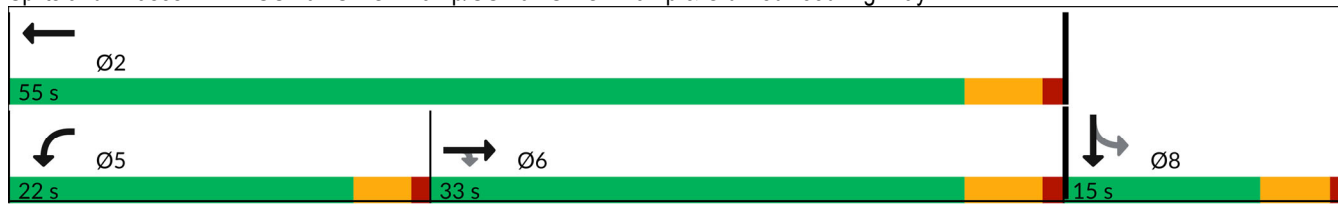

















Area Type: Other  
 Cycle Length: 70  
 Actuated Cycle Length: 70  
 Natural Cycle: 90  
 Control Type: Actuated-Uncoordinated  
 Maximum v/c Ratio: 1.45  
 Intersection Signal Delay (s/veh): 52.5  
 Intersection LOS: D  
 Intersection Capacity Utilization 83.7%  
 ICU Level of Service E  
 Analysis Period (min) 15

Splits and Phases: 12: US 101 SB On Ramp/US 101 SB Off Ramp & Old Redwood Highway



Lanes, Volumes, Timings  
1: Old Redwood Hwy & Shiloh Road

General Plan 2040 Project Altern. B Conditions  
Timing Plan: Saturday Midday Peak

												
Lane Group	EBL	EBT	EBR	WBL	WBT	WBR	NBL	NBT	NBR	SBL	SBT	SBR
Lane Configurations												
Traffic Volume (vph)	182	475	301	31	510	76	314	351	35	79	284	266
Future Volume (vph)	182	475	301	31	510	76	314	351	35	79	284	266
Ideal Flow (vphpl)	1900	1900	1900	1900	1900	1900	1900	1900	1900	1900	1900	1900
Storage Length (ft)	375		140	0		50	200		98	130		93
Storage Lanes	1		1	0		1	1		1	1		1
Taper Length (ft)	50			25			60			93		
Lane Util. Factor	1.00	1.00	1.00	1.00	1.00	1.00	1.00	1.00	1.00	1.00	1.00	1.00
Ped Bike Factor	1.00		0.98						0.98			0.97
Frt			0.850			0.850			0.850			0.850
Flt Protected	0.950				0.997		0.950			0.950		
Satd. Flow (prot)	1770	1863	1583	0	1857	1583	1770	1863	1583	1770	1863	1583
Flt Permitted	0.950				0.997		0.950			0.950		
Satd. Flow (perm)	1764	1863	1549	0	1857	1583	1770	1863	1550	1770	1863	1540
Right Turn on Red			Yes			Yes			Yes			Yes
Satd. Flow (RTOR)			144			113			81			159
Link Speed (mph)		40			40			45			40	
Link Distance (ft)		1789			608			748			775	
Travel Time (s)		30.5			10.4			11.3			13.2	
Confl. Peds. (#/hr)	4											
Confl. Bikes (#/hr)			1						1			5
Peak Hour Factor	0.89	0.89	0.89	0.86	0.86	0.86	0.93	0.93	0.93	0.91	0.91	0.91
Adj. Flow (vph)	204	534	338	36	593	88	338	377	38	87	312	292
Shared Lane Traffic (%)												
Lane Group Flow (vph)	204	534	338	0	629	88	338	377	38	87	312	292
Enter Blocked Intersection	No	No	No	No	No	No	No	No	No	No	No	No
Lane Alignment	Left	Left	Right	Left	Left	Right	Left	Left	Right	Left	Left	Right
Median Width(ft)		12			12			12			12	
Link Offset(ft)		0			0			0			0	
Crosswalk Width(ft)		16			16			16			16	
Two way Left Turn Lane												
Headway Factor	1.00	1.00	1.00	1.00	1.00	1.00	1.00	1.00	1.00	1.00	1.00	1.00
Turning Speed (mph)	15		9	15		9	15		9	15		9
Number of Detectors	1	2	1	1	2	1	1	2	1	1	2	1
Detector Template	Left	Thru	Right	Left	Thru	Right	Left	Thru	Right	Left	Thru	Right
Leading Detector (ft)	20	100	20	20	100	20	20	100	20	20	100	20
Trailing Detector (ft)	0	0	0	0	0	0	0	0	0	0	0	0
Detector 1 Position(ft)	0	0	0	0	0	0	0	0	0	0	0	0
Detector 1 Size(ft)	20	6	20	20	6	20	20	6	20	20	6	20
Detector 1 Type	Cl+Ex	Cl+Ex	Cl+Ex	Cl+Ex	Cl+Ex	Cl+Ex	Cl+Ex	Cl+Ex	Cl+Ex	Cl+Ex	Cl+Ex	Cl+Ex
Detector 1 Channel												
Detector 1 Extend (s)	0.0	0.0	0.0	0.0	0.0	0.0	0.0	0.0	0.0	0.0	0.0	0.0
Detector 1 Queue (s)	0.0	0.0	0.0	0.0	0.0	0.0	0.0	0.0	0.0	0.0	0.0	0.0
Detector 1 Delay (s)	0.0	0.0	0.0	0.0	0.0	0.0	0.0	0.0	0.0	0.0	0.0	0.0
Detector 2 Position(ft)		94			94			94			94	
Detector 2 Size(ft)		6			6			6			6	
Detector 2 Type		Cl+Ex			Cl+Ex			Cl+Ex			Cl+Ex	
Detector 2 Channel												
Detector 2 Extend (s)		0.0			0.0			0.0			0.0	

Lanes, Volumes, Timings  
1: Old Redwood Hwy & Shiloh Road

General Plan 2040 Project Altern. B Conditions

Timing Plan: Saturday Midday Peak

Lane Group	EBL	EBT	EBR	WBL	WBT	WBR	NBL	NBT	NBR	SBL	SBT	SBR
Turn Type	Split	NA	Perm	Split	NA	Perm	Prot	NA	Perm	Prot	NA	Perm
Protected Phases	2	2		6	6		3	8		7	4	
Permitted Phases			2			6			8			4
Detector Phase	2	2	2	6	6	6	3	8	8	7	4	4
Switch Phase												
Minimum Initial (s)	5.0	5.0	5.0	5.0	5.0	5.0	5.0	5.0	5.0	5.0	5.0	5.0
Minimum Split (s)	34.5	34.5	34.5	42.5	42.5	42.5	9.0	46.5	46.5	9.0	39.5	39.5
Total Split (s)	35.0	35.0	35.0	42.5	42.5	42.5	18.0	48.0	48.0	9.5	39.5	39.5
Total Split (%)	25.9%	25.9%	25.9%	31.5%	31.5%	31.5%	13.3%	35.6%	35.6%	7.0%	29.3%	29.3%
Maximum Green (s)	30.5	30.5	30.5	38.0	38.0	38.0	14.0	43.5	43.5	5.5	35.0	35.0
Yellow Time (s)	3.5	3.5	3.5	3.5	3.5	3.5	3.5	3.5	3.5	3.5	3.5	3.5
All-Red Time (s)	1.0	1.0	1.0	1.0	1.0	1.0	0.5	1.0	1.0	0.5	1.0	1.0
Lost Time Adjust (s)	0.0	0.0	0.0		0.0	0.0	0.0	0.0	0.0	0.0	0.0	0.0
Total Lost Time (s)	4.5	4.5	4.5		4.5	4.5	4.0	4.5	4.5	4.0	4.5	4.5
Lead/Lag	Lead	Lead	Lead	Lag	Lag	Lag	Lead	Lag	Lag	Lead	Lag	Lag
Lead-Lag Optimize?	Yes	Yes	Yes	Yes	Yes	Yes	Yes	Yes	Yes	Yes	Yes	Yes
Vehicle Extension (s)	3.0	3.0	3.0	3.0	3.0	3.0	3.0	3.0	3.0	3.0	3.0	3.0
Recall Mode	None	None	None	None	None	None	None	None	None	None	None	None
Walk Time (s)	7.0	7.0	7.0	7.0	7.0	7.0		7.0	7.0		7.0	7.0
Flash Don't Walk (s)	23.0	23.0	23.0	31.0	31.0	31.0		35.0	35.0		28.0	28.0
Pedestrian Calls (#/hr)	0	0	0	0	0	0		0	0		0	0
Act Effct Green (s)	30.6	30.6	30.6		38.1	38.1	14.0	34.9	34.9	5.5	26.3	26.3
Actuated g/C Ratio	0.24	0.24	0.24		0.30	0.30	0.11	0.28	0.28	0.04	0.21	0.21
v/c Ratio	0.48	1.19	0.70		1.13	0.16	1.72	0.73	0.08	1.13	0.81	0.65
Control Delay (s/veh)	46.8	147.1	34.2		118.9	3.7	380.8	50.7	0.3	197.8	63.8	27.3
Queue Delay	0.0	0.0	0.0		0.0	0.0	0.0	0.0	0.0	0.0	0.0	0.0
Total Delay (s/veh)	46.8	147.1	34.2		118.9	3.7	380.8	50.7	0.3	197.8	63.8	27.3
LOS	D	F	C		F	A	F	D	A	F	E	C
Approach Delay (s/veh)		92.7			104.7			196.3			65.2	
Approach LOS		F			F			F			E	

Intersection Summary

Area Type: Other  
 Cycle Length: 135  
 Actuated Cycle Length: 126.6  
 Natural Cycle: 145  
 Control Type: Actuated-Uncoordinated  
 Maximum v/c Ratio: 1.72  
 Intersection Signal Delay (s/veh): 113.6  
 Intersection LOS: F  
 Intersection Capacity Utilization 100.5%  
 ICU Level of Service G  
 Analysis Period (min) 15

Splits and Phases: 1: Old Redwood Hwy & Shiloh Road

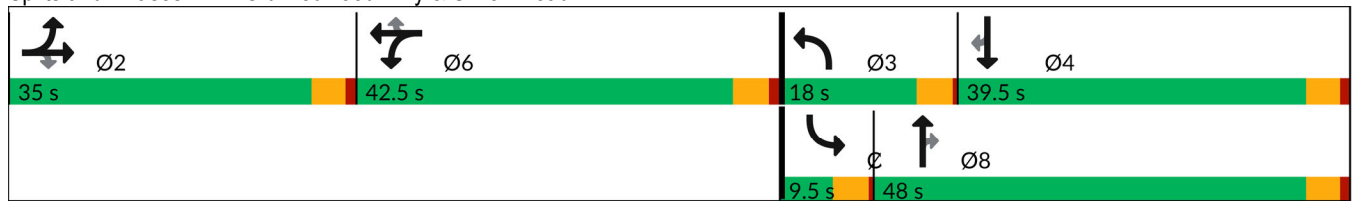



Lanes, Volumes, Timings  
2: Shiloh Road & Hembree Ln

General Plan 2040 Project Altern. B Conditions  
Timing Plan: Saturday Midday Peak

Lane Group	EBL	EBT	EBR	WBL	WBT	WBR	NBL	NBT	NBR	SBL	SBT	SBR
Lane Configurations												
Traffic Volume (vph)	918	827	69	110	796	235	110	21	128	236	11	856
Future Volume (vph)	918	827	69	110	796	235	110	21	128	236	11	856
Ideal Flow (vphpl)	1900	1900	1900	1900	1900	1900	1900	1900	1900	1900	1900	1900
Storage Length (ft)	0		0	100		130	0		0	0		0
Storage Lanes	2		0	1		1	1		0	0		1
Taper Length (ft)	25			50			25			25		
Lane Util. Factor	0.97	1.00	1.00	1.00	0.95	0.95	1.00	1.00	1.00	1.00	1.00	1.00
Ped Bike Factor	1.00				1.00							
Frt		0.989			0.966			0.871				0.850
Flt Protected	0.950			0.950			0.950				0.954	
Satd. Flow (prot)	3433	1842	0	1770	3409	0	1770	1622	0	0	1777	1583
Flt Permitted	0.950			0.950			0.950				0.954	
Satd. Flow (perm)	3432	1842	0	1770	3409	0	1770	1622	0	0	1777	1583
Right Turn on Red			Yes			Yes			Yes			Yes
Satd. Flow (RTOR)		8			57			128				100
Link Speed (mph)		40			40			30				35
Link Distance (ft)		302			1789			216				381
Travel Time (s)		5.1			30.5			4.9				7.4
Confl. Peds. (#/hr)	1						1					
Peak Hour Factor	0.94	0.94	1.00	1.00	0.96	0.96	1.00	1.00	1.00	0.91	1.00	0.91
Adj. Flow (vph)	977	880	69	110	829	245	110	21	128	259	11	941
Shared Lane Traffic (%)												
Lane Group Flow (vph)	977	949	0	110	1074	0	110	149	0	0	270	941
Enter Blocked Intersection	No	No	No	No	No	No	No	No	No	No	No	No
Lane Alignment	Left	Left	Right	Left	Left	Right	Left	Left	Right	Left	Left	Right
Median Width(ft)		24			24			12				12
Link Offset(ft)		0			0			0				0
Crosswalk Width(ft)		16			16			16				16
Two way Left Turn Lane												
Headway Factor	1.00	1.00	1.00	1.00	1.00	1.00	1.00	1.00	1.00	1.00	1.00	1.00
Turning Speed (mph)	15		9	15		9	15		9	15		9
Number of Detectors	1	2		1	2		1	2		1	2	1
Detector Template	Left	Thru		Left	Thru		Left	Thru		Left	Thru	Right
Leading Detector (ft)	20	100		20	100		20	100		20	100	20
Trailing Detector (ft)	0	0		0	0		0	0		0	0	0
Detector 1 Position(ft)	0	0		0	0		0	0		0	0	0
Detector 1 Size(ft)	20	6		20	6		20	6		20	6	20
Detector 1 Type	Cl+Ex	Cl+Ex		Cl+Ex	Cl+Ex		Cl+Ex	Cl+Ex		Cl+Ex	Cl+Ex	Cl+Ex
Detector 1 Channel												
Detector 1 Extend (s)	0.0	0.0		0.0	0.0		0.0	0.0		0.0	0.0	0.0
Detector 1 Queue (s)	0.0	0.0		0.0	0.0		0.0	0.0		0.0	0.0	0.0
Detector 1 Delay (s)	0.0	0.0		0.0	0.0		0.0	0.0		0.0	0.0	0.0
Detector 2 Position(ft)		94			94			94				94
Detector 2 Size(ft)		6			6			6				6
Detector 2 Type		Cl+Ex			Cl+Ex			Cl+Ex				Cl+Ex
Detector 2 Channel												
Detector 2 Extend (s)		0.0			0.0			0.0				0.0
Turn Type	Prot	NA		Prot	NA		Split	NA		Split	NA	pt+ov

Lanes, Volumes, Timings  
2: Shiloh Road & Hembree Ln

General Plan 2040 Project Altern. B Conditions  
Timing Plan: Saturday Midday Peak

Lane Group	EBL	EBT	EBR	WBL	WBT	WBR	NBL	NBT	NBR	SBL	SBT	SBR
Protected Phases	5	2		1	6		8	8		4	4	4 5
Permitted Phases												
Detector Phase	5	2		1	6		8	8		4	4	4 5
Switch Phase												
Minimum Initial (s)	3.0	5.0		5.0	5.0		5.0	5.0		5.0	5.0	
Minimum Split (s)	7.5	9.5		9.5	43.5		9.5	9.5		9.5	9.5	
Total Split (s)	21.0	57.0		9.5	45.5		9.5	9.5		14.0	14.0	
Total Split (%)	23.3%	63.3%		10.6%	50.6%		10.6%	10.6%		15.6%	15.6%	
Maximum Green (s)	17.0	53.0		5.5	41.5		5.5	5.5		10.0	10.0	
Yellow Time (s)	3.0	3.0		3.0	3.0		3.0	3.0		3.0	3.0	
All-Red Time (s)	1.0	1.0		1.0	1.0		1.0	1.0		1.0	1.0	
Lost Time Adjust (s)	0.0	0.0		0.0	0.0		0.0	0.0		0.0	0.0	
Total Lost Time (s)	4.0	4.0		4.0	4.0		4.0	4.0		4.0	4.0	
Lead/Lag	Lead	Lag		Lead	Lag							
Lead-Lag Optimize?	Yes	Yes		Yes	Yes							
Vehicle Extension (s)	3.0	3.0		3.0	3.0		3.0	3.0		3.0	3.0	
Recall Mode	None	None		None	None		None	None		None	None	
Walk Time (s)					7.0							
Flash Don't Walk (s)					32.0							
Pedestrian Calls (#/hr)					1							
Act Effct Green (s)	17.2	46.9		5.6	35.2		5.6	5.6		10.1	27.3	
Actuated g/C Ratio	0.20	0.56		0.07	0.42		0.07	0.07		0.12	0.32	
v/c Ratio	1.40	0.92		0.95	0.74		0.95	0.66		1.27	1.63	
Control Delay (s/veh)	217.0	32.3		114.9	22.4		114.9	26.4		187.9	310.1	
Queue Delay	0.0	1.0		0.0	0.0		0.0	0.0		0.0	0.0	
Total Delay (s/veh)	217.0	33.3		114.9	22.4		114.9	26.4		187.9	310.1	
LOS	F	C		F	C		F	C		F	F	
Approach Delay (s/veh)		126.5			31.0			64.0			282.8	
Approach LOS		F			C			E			F	

Intersection Summary







Area Type:	Other
Cycle Length:	90
Actuated Cycle Length:	84.2
Natural Cycle:	150
Control Type:	Actuated-Uncoordinated
Maximum v/c Ratio:	1.63
Intersection Signal Delay (s/veh):	139.6
Intersection LOS:	F
Intersection Capacity Utilization:	101.6%
ICU Level of Service:	G
Analysis Period (min):	15

Splits and Phases: 2: Shiloh Road & Hembree Ln



Lanes, Volumes, Timings  
3: US 101 NB Off-Ramp & Shiloh Road

General Plan 2040 Project Altern. B Conditions  
Timing Plan: Saturday Midday Peak

						
Lane Group	EBT	EBR	WBL	WBT	NBL	NBR
Lane Configurations	↑↑			↑	↘	↗↗
Traffic Volume (vph)	705	0	0	1233	520	1038
Future Volume (vph)	705	0	0	1233	520	1038
Ideal Flow (vphpl)	1900	1900	1900	1900	1900	1900
Storage Length (ft)		0	0		0	265
Storage Lanes		0	0		1	2
Taper Length (ft)			25		25	
Lane Util. Factor	0.95	1.00	1.00	1.00	1.00	0.88
Ped Bike Factor						
Frt						0.850
Flt Protected					0.950	
Satd. Flow (prot)	3539	0	0	1863	1770	2787
Flt Permitted					0.950	
Satd. Flow (perm)	3539	0	0	1863	1770	2787
Right Turn on Red		Yes				Yes
Satd. Flow (RTOR)						198
Link Speed (mph)	40			40	30	
Link Distance (ft)	186			371	769	
Travel Time (s)	3.2			6.3	17.5	
Confl. Bikes (#/hr)		1				
Peak Hour Factor	0.91	0.91	0.89	0.89	0.95	0.95
Adj. Flow (vph)	775	0	0	1385	547	1093
Shared Lane Traffic (%)						
Lane Group Flow (vph)	775	0	0	1385	547	1093
Enter Blocked Intersection	No	No	No	No	No	No
Lane Alignment	Left	Right	Left	Left	Left	Right
Median Width(ft)	0			0	12	
Link Offset(ft)	0			0	0	
Crosswalk Width(ft)	16			16	16	
Two way Left Turn Lane						
Headway Factor	1.00	1.00	1.00	1.00	1.00	1.00
Turning Speed (mph)		9	15		15	9
Number of Detectors	2			2	1	1
Detector Template	Thru			Thru	Left	Right
Leading Detector (ft)	100			100	20	20
Trailing Detector (ft)	0			0	0	0
Detector 1 Position(ft)	0			0	0	0
Detector 1 Size(ft)	6			6	20	20
Detector 1 Type	Cl+Ex			Cl+Ex	Cl+Ex	Cl+Ex
Detector 1 Channel						
Detector 1 Extend (s)	0.0			0.0	0.0	0.0
Detector 1 Queue (s)	0.0			0.0	0.0	0.0
Detector 1 Delay (s)	0.0			0.0	0.0	0.0
Detector 2 Position(ft)	94			94		
Detector 2 Size(ft)	6			6		
Detector 2 Type	Cl+Ex			Cl+Ex		
Detector 2 Channel						
Detector 2 Extend (s)	0.0			0.0		
Turn Type	NA			NA	Prot	Perm

Lanes, Volumes, Timings  
 3: US 101 NB Off-Ramp & Shiloh Road

General Plan 2040 Project Altern. B Conditions  
 Timing Plan: Saturday Midday Peak

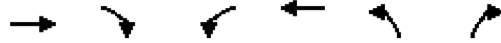

Lane Group	EBT	EBR	WBL	WBT	NBL	NBR
Protected Phases	2			6	8	
Permitted Phases						8
Detector Phase	2			6	8	8
Switch Phase						
Minimum Initial (s)	5.0			5.0	5.0	5.0
Minimum Split (s)	9.5			9.5	9.5	9.5
Total Split (s)	37.0			37.0	35.0	35.0
Total Split (%)	51.4%			51.4%	48.6%	48.6%
Maximum Green (s)	32.5			32.5	30.5	30.5
Yellow Time (s)	3.5			3.5	3.5	3.5
All-Red Time (s)	1.0			1.0	1.0	1.0
Lost Time Adjust (s)	0.0			0.0	0.0	0.0
Total Lost Time (s)	4.5			4.5	4.5	4.5
Lead/Lag						
Lead-Lag Optimize?						
Vehicle Extension (s)	3.0			3.0	3.0	3.0
Recall Mode	None			None	None	None
Act Effct Green (s)	32.6			32.6	28.3	28.3
Actuated g/C Ratio	0.47			0.47	0.40	0.40
v/c Ratio	0.47			1.60	0.76	0.88
Control Delay (s/veh)	14.4			295.1	26.1	25.2
Queue Delay	0.0			0.0	0.0	0.0
Total Delay (s/veh)	14.4			295.1	26.1	25.2
LOS	B			F	C	C
Approach Delay (s/veh)	14.4			295.1	25.5	
Approach LOS	B			F	C	

Intersection Summary

Area Type:	Other
Cycle Length:	72
Actuated Cycle Length:	69.9
Natural Cycle:	140
Control Type:	Actuated-Uncoordinated
Maximum v/c Ratio:	1.60
Intersection Signal Delay (s/veh):	121.5
Intersection LOS:	F
Intersection Capacity Utilization:	165.9%
ICU Level of Service:	H
Analysis Period (min):	15

Splits and Phases: 3: US 101 NB Off-Ramp & Shiloh Road

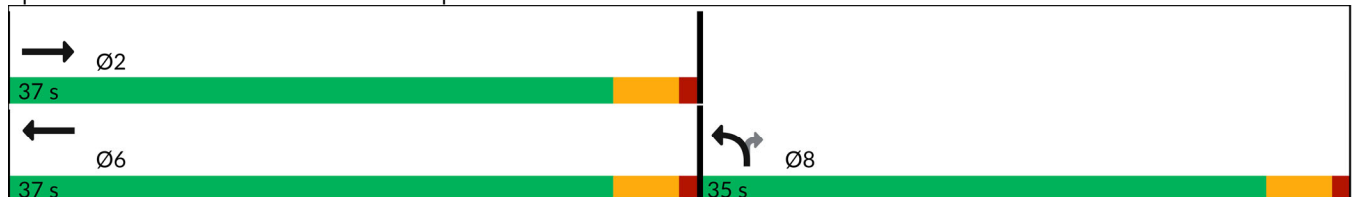

Lanes, Volumes, Timings  
4: Shiloh Road & US 101 SB Off-Ramp

General Plan 2040 Project Altern. B Conditions  
Timing Plan: Saturday Midday Peak

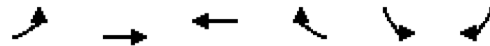

Lane Group	EBL	EBT	WBT	WBR	SBL	SBR
Lane Configurations		↑	↑		↘	↘
Traffic Volume (vph)	0	421	793	0	400	223
Future Volume (vph)	0	421	793	0	400	223
Ideal Flow (vphp)	1900	1900	1900	1900	1900	1900
Storage Length (ft)	0			0	0	275
Storage Lanes	0			0	1	1
Taper Length (ft)	25				25	
Lane Util. Factor	1.00	1.00	1.00	1.00	1.00	1.00
Ped Bike Factor						
Frt						0.850
Flt Protected					0.950	
Satd. Flow (prot)	0	1863	1863	0	1770	1583
Flt Permitted					0.950	
Satd. Flow (perm)	0	1863	1863	0	1770	1583
Right Turn on Red				Yes		Yes
Satd. Flow (RTOR)						243
Link Speed (mph)		40	40		30	
Link Distance (ft)		225	306		486	
Travel Time (s)		3.8	5.2		11.0	
Confl. Bikes (#/hr)				2		
Peak Hour Factor	0.96	0.96	0.96	0.96	0.68	0.68
Adj. Flow (vph)	0	439	826	0	588	328
Shared Lane Traffic (%)						
Lane Group Flow (vph)	0	439	826	0	588	328
Enter Blocked Intersection	No	No	No	No	No	No
Lane Alignment	Left	Left	Left	Right	Left	Right
Median Width(ft)		4	0		12	
Link Offset(ft)		0	0		0	
Crosswalk Width(ft)		16	16		16	
Two way Left Turn Lane						
Headway Factor	1.00	1.00	1.00	1.00	1.00	1.00
Turning Speed (mph)	15			9	15	9
Number of Detectors		2	2		1	1
Detector Template		Thru	Thru		Left	Right
Leading Detector (ft)		100	100		20	20
Trailing Detector (ft)		0	0		0	0
Detector 1 Position(ft)		0	0		0	0
Detector 1 Size(ft)		6	6		20	20
Detector 1 Type		Cl+Ex	Cl+Ex		Cl+Ex	Cl+Ex
Detector 1 Channel						
Detector 1 Extend (s)		0.0	0.0		0.0	0.0
Detector 1 Queue (s)		0.0	0.0		0.0	0.0
Detector 1 Delay (s)		0.0	0.0		0.0	0.0
Detector 2 Position(ft)		94	94			
Detector 2 Size(ft)		6	6			
Detector 2 Type		Cl+Ex	Cl+Ex			
Detector 2 Channel						
Detector 2 Extend (s)		0.0	0.0			
Turn Type		NA	NA		Perm	Perm

Lanes, Volumes, Timings  
4: Shiloh Road & US 101 SB Off-Ramp

General Plan 2040 Project Altern. B Conditions  
Timing Plan: Saturday Midday Peak

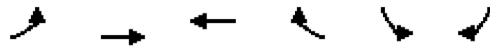

Lane Group	EBL	EBT	WBT	WBR	SBL	SBR
Protected Phases		2	6			
Permitted Phases					4	4
Detector Phase		2	6		4	4
Switch Phase						
Minimum Initial (s)		5.0	5.0		5.0	5.0
Minimum Split (s)		9.5	38.5		9.5	9.5
Total Split (s)		69.0	69.0		21.0	21.0
Total Split (%)		76.7%	76.7%		23.3%	23.3%
Maximum Green (s)		64.5	64.5		16.5	16.5
Yellow Time (s)		3.5	3.5		3.5	3.5
All-Red Time (s)		1.0	1.0		1.0	1.0
Lost Time Adjust (s)		0.0	0.0		0.0	0.0
Total Lost Time (s)		4.5	4.5		4.5	4.5
Lead/Lag						
Lead-Lag Optimize?						
Vehicle Extension (s)		3.0	3.0		3.0	3.0
Recall Mode		None	None		None	None
Walk Time (s)			7.0			
Flash Don't Walk (s)			27.0			
Pedestrian Calls (#/hr)			0			
Act Effct Green (s)		30.7	30.7		16.9	16.9
Actuated g/C Ratio		0.54	0.54		0.30	0.30
v/c Ratio		0.44	0.82		1.12	0.51
Control Delay (s/veh)		8.8	18.0		101.6	9.7
Queue Delay		0.0	0.0		0.0	0.0
Total Delay (s/veh)		8.8	18.0		101.6	9.7
LOS		A	B		F	A
Approach Delay (s/veh)		8.8	18.0		68.7	
Approach LOS		A	B		E	

Intersection Summary

Area Type:	Other
Cycle Length:	90
Actuated Cycle Length:	56.9
Natural Cycle:	70
Control Type:	Actuated-Uncoordinated
Maximum v/c Ratio:	1.12
Intersection Signal Delay (s/veh):	37.4
Intersection LOS:	D
Intersection Capacity Utilization:	154.9%
ICU Level of Service:	H
Analysis Period (min):	15

Splits and Phases: 4: Shiloh Road & US 101 SB Off-Ramp

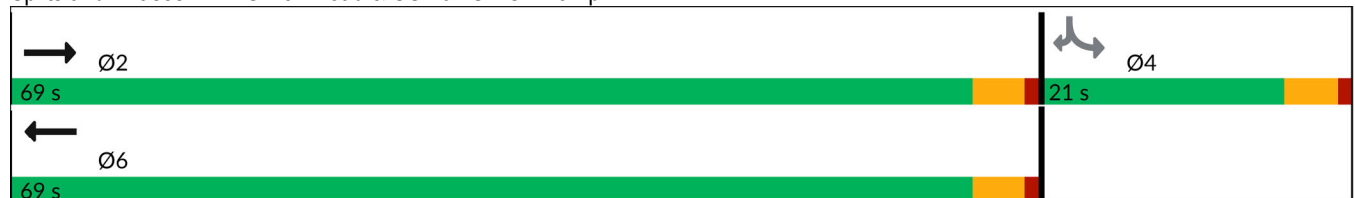

Lanes, Volumes, Timings  
5: Caletti Ave & Shiloh Road

General Plan 2040 Project Altern. B Conditions

Timing Plan: Saturday Midday Peak



















	→	↘	↙	←	↖	↗
Lane Group	EBT	EBR	WBL	WBT	NBL	NBR
Lane Configurations	↑↑		↘	↑	↘	↗
Traffic Volume (vph)	823	30	120	910	24	115
Future Volume (vph)	823	30	120	910	24	115
Ideal Flow (vphp)	1900	1900	1900	1900	1900	1900
Storage Length (ft)		0	68		0	0
Storage Lanes		0	1		1	1
Taper Length (ft)			50		25	
Lane Util. Factor	0.95	0.95	1.00	1.00	1.00	1.00
Ped Bike Factor						
Frt	0.995					0.850
Flt Protected			0.950		0.950	
Satd. Flow (prot)	3522	0	1770	1863	1770	1583
Flt Permitted			0.950		0.950	
Satd. Flow (perm)	3522	0	1770	1863	1770	1583
Link Speed (mph)	40			40	30	
Link Distance (ft)	1081			184	459	
Travel Time (s)	18.4			3.1	10.4	
Confl. Peds. (#/hr)					1	
Confl. Bikes (#/hr)		1				
Peak Hour Factor	0.92	0.92	0.87	0.87	0.78	0.78
Adj. Flow (vph)	895	33	138	1046	31	147
Shared Lane Traffic (%)						
Lane Group Flow (vph)	928	0	138	1046	31	147
Enter Blocked Intersection	No	No	No	No	No	No
Lane Alignment	Left	Right	Left	Left	Left	Right
Median Width(ft)	12			12	12	
Link Offset(ft)	0			0	0	
Crosswalk Width(ft)	16			16	16	
Two way Left Turn Lane						
Headway Factor	1.00	1.00	1.00	1.00	1.00	1.00
Turning Speed (mph)		9	15		15	9
Sign Control	Free			Free	Stop	

Intersection Summary

Area Type:	Other
Control Type:	Unsignalized
Intersection Capacity Utilization	57.9%
Analysis Period (min)	15
	ICU Level of Service B

Lanes, Volumes, Timings  
6: Conde Lane & Shiloh Road

General Plan 2040 Project Altern. B Conditions  
Timing Plan: Saturday Midday Peak

												
Lane Group	EBL	EBT	EBR	WBL	WBT	WBR	NBL	NBT	NBR	SBL	SBT	SBR
Lane Configurations												
Traffic Volume (vph)	43	551	1	13	613	301	1	0	9	291	0	41
Future Volume (vph)	43	551	1	13	613	301	1	0	9	291	0	41
Ideal Flow (vphpl)	1900	1900	1900	1900	1900	1900	1900	1900	1900	1900	1900	1900
Storage Length (ft)	90		0	127		0	0		0	0		40
Storage Lanes	1		0	1		0	0		0	0		1
Taper Length (ft)	70			40			25			25		
Lane Util. Factor	1.00	0.95	0.95	1.00	0.95	0.95	1.00	1.00	1.00	1.00	1.00	1.00
Ped Bike Factor					0.99							
Frt					0.951			0.880				0.850
Flt Protected	0.950			0.950				0.994			0.950	
Satd. Flow (prot)	1770	3539	0	1770	3341	0	0	1629	0	0	1770	1583
Flt Permitted	0.950			0.950				0.994			0.950	
Satd. Flow (perm)	1770	3539	0	1770	3341	0	0	1629	0	0	1770	1583
Right Turn on Red			Yes			Yes			Yes			No
Satd. Flow (RTOR)					85			102				
Link Speed (mph)		40			40			30				35
Link Distance (ft)		815			1081			418				522
Travel Time (s)		13.9			18.4			9.5				10.2
Confl. Bikes (#/hr)						2						
Peak Hour Factor	0.96	0.96	0.96	0.91	0.91	0.91	0.58	0.58	0.58	0.78	0.78	0.78
Adj. Flow (vph)	45	574	1	14	674	331	2	0	16	373	0	53
Shared Lane Traffic (%)												
Lane Group Flow (vph)	45	575	0	14	1005	0	0	18	0	0	373	53
Enter Blocked Intersection	No	No	No	No	No	No	No	No	No	No	No	No
Lane Alignment	Left	Left	Right	Left	Left	Right	Left	Left	Right	Left	Left	Right
Median Width(ft)		12			12			0				0
Link Offset(ft)		0			0			0				0
Crosswalk Width(ft)		16			16			16				16
Two way Left Turn Lane												
Headway Factor	1.00	1.00	1.00	1.00	1.00	1.00	1.00	1.00	1.00	1.00	1.00	1.00
Turning Speed (mph)	15		9	15		9	15		9	15		9
Number of Detectors	1	2		1	2		1	2		1	1	1
Detector Template	Left	Thru		Left	Thru		Left	Thru		Left	Thru	Right
Leading Detector (ft)	20	100		20	100		20	100		20	30	20
Trailing Detector (ft)	0	0		0	0		0	0		0	0	0
Detector 1 Position(ft)	0	0		0	0		0	0		0	0	0
Detector 1 Size(ft)	20	6		20	6		20	6		20	30	20
Detector 1 Type	Cl+Ex	Cl+Ex		Cl+Ex	Cl+Ex		Cl+Ex	Cl+Ex		Cl+Ex	Cl+Ex	Cl+Ex
Detector 1 Channel												
Detector 1 Extend (s)	0.0	0.0		0.0	0.0		0.0	0.0		0.0	0.0	0.0
Detector 1 Queue (s)	0.0	0.0		0.0	0.0		0.0	0.0		0.0	0.0	0.0
Detector 1 Delay (s)	0.0	0.0		0.0	0.0		0.0	0.0		0.0	0.0	0.0
Detector 2 Position(ft)		94			94			94				
Detector 2 Size(ft)		6			6			6				
Detector 2 Type		Cl+Ex			Cl+Ex			Cl+Ex				
Detector 2 Channel												
Detector 2 Extend (s)		0.0			0.0			0.0				
Turn Type	Prot	NA		Prot	NA		Split	NA		Split	NA	custom



Lanes, Volumes, Timings  
6: Conde Lane & Shiloh Road

General Plan 2040 Project Altern. B Conditions  
Timing Plan: Saturday Midday Peak

Lane Group	EBL	EBT	EBR	WBL	WBT	WBR	NBL	NBT	NBR	SBL	SBT	SBR
Protected Phases	5	2		1	6		7	7		4	4	
Permitted Phases												6
Detector Phase	5	2		1	6		7	7		4	4	6
Switch Phase												
Minimum Initial (s)	8.0	8.0		8.0	8.0		10.0	10.0		11.0	11.0	8.0
Minimum Split (s)	12.5	46.5		12.5	12.5		37.5	37.5		15.5	15.5	12.5
Total Split (s)	13.0	46.5		12.5	45.0		37.5	37.5		15.5	15.5	45.0
Total Split (%)	11.6%	41.5%		11.2%	40.2%		33.5%	33.5%		13.8%	13.8%	40.2%
Maximum Green (s)	8.5	42.0		8.0	40.5		33.0	33.0		11.0	11.0	40.5
Yellow Time (s)	3.5	3.5		3.5	3.5		3.5	3.5		3.5	3.5	3.5
All-Red Time (s)	1.0	1.0		1.0	1.0		1.0	1.0		1.0	1.0	1.0
Lost Time Adjust (s)	0.0	0.0		0.0	0.0		0.0	0.0		0.0	0.0	0.0
Total Lost Time (s)	4.5	4.5		4.5	4.5		4.5	4.5		4.5	4.5	4.5
Lead/Lag	Lead	Lag		Lead	Lag							Lag
Lead-Lag Optimize?	Yes	Yes		Yes	Yes							Yes
Vehicle Extension (s)	3.0	3.0		3.0	3.0		3.0	3.0		3.0	3.0	3.0
Recall Mode	None	None		None	None		None	None		None	None	None
Walk Time (s)		7.0					7.0	7.0				
Flash Don't Walk (s)		35.0					26.0	26.0				
Pedestrian Calls (#/hr)		0					0	0				
Act Effct Green (s)	9.3	30.7		9.2	26.1		11.5			12.6	26.1	
Actuated g/C Ratio	0.16	0.52		0.15	0.44		0.19			0.21	0.44	
v/c Ratio	0.16	0.31		0.05	0.67		0.05			0.99	0.08	
Control Delay (s/veh)	33.0	9.7		33.5	15.9		0.2			79.8	13.0	
Queue Delay	0.0	0.0		0.0	0.0		0.0			0.0	0.0	
Total Delay (s/veh)	33.0	9.7		33.5	15.9		0.2			79.8	13.0	
LOS	C	A		C	B		A			E	B	
Approach Delay (s/veh)		11.4			16.1		0.2			71.5		
Approach LOS		B			B		A			E		

Intersection Summary

Area Type:	Other
Cycle Length:	112
Actuated Cycle Length:	59.5
Natural Cycle:	125
Control Type:	Actuated-Uncoordinated
Maximum v/c Ratio:	0.99
Intersection Signal Delay (s/veh):	25.9
Intersection LOS:	C
Intersection Capacity Utilization:	66.0%
ICU Level of Service:	C
Analysis Period (min):	15

Splits and Phases: 6: Conde Lane & Shiloh Road

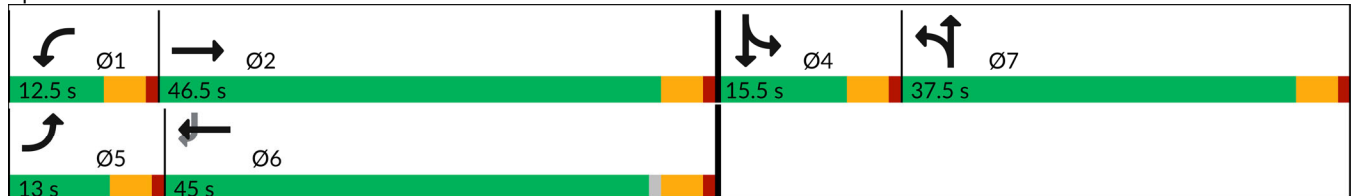

Lanes, Volumes, Timings  
7: Driveway 1/Gridley Drive & Shiloh Road





















General Plan 2040 Project Altern. B Conditions  
Timing Plan: Saturday Midday Peak

Lane Group	EBL	EBT	EBR	WBL	WBT	WBR	NBL	NBT	NBR	SBL	SBT	SBR
Lane Configurations												
Traffic Volume (vph)	30	473	103	0	482	0	113	0	0	0	0	27
Future Volume (vph)	30	473	103	0	482	0	113	0	0	0	0	27
Ideal Flow (vphp)	1900	1900	1900	1900	1900	1900	1900	1900	1900	1900	1900	1900
Storage Length (ft)	0		150	0		0	0		0	0		0
Storage Lanes	0		1	0		0	1		0	0		0
Taper Length (ft)	25			25			25			25		
Lane Util. Factor	1.00	1.00	1.00	1.00	1.00	1.00	1.00	1.00	1.00	1.00	1.00	1.00
Ped Bike Factor												
Frt			0.850								0.865	
Flt Protected		0.997					0.950					
Satd. Flow (prot)	0	1857	1583	0	1863	0	1770	1863	0	0	1611	0
Flt Permitted		0.997					0.950					
Satd. Flow (perm)	0	1857	1583	0	1863	0	1770	1863	0	0	1611	0
Link Speed (mph)		40			40			30			30	
Link Distance (ft)		608			2146			248			715	
Travel Time (s)		10.4			36.6			5.6			16.3	
Confl. Peds. (#/hr)	1											
Confl. Bikes (#/hr)			1			3						
Peak Hour Factor	0.93	0.93	0.93	0.88	0.88	0.88	1.00	1.00	1.00	0.56	0.56	0.56
Adj. Flow (vph)	32	509	111	0	548	0	113	0	0	0	0	48
Shared Lane Traffic (%)												
Lane Group Flow (vph)	0	541	111	0	548	0	113	0	0	0	48	0
Enter Blocked Intersection	No	No	No	No	No	No	No	No	No	No	No	No
Lane Alignment	Left	Left	Right	Left	Left	Right	Left	Left	Right	Left	Left	Right
Median Width(ft)		0			0			12			12	
Link Offset(ft)		0			0			0			0	
Crosswalk Width(ft)		16			16			16			16	
Two way Left Turn Lane												
Headway Factor	1.00	1.00	1.00	1.00	1.00	1.00	1.00	1.00	1.00	1.00	1.00	1.00
Turning Speed (mph)	15		9	15		9	15		9	15		9
Sign Control		Free			Free			Stop			Stop	

Intersection Summary	
Area Type:	Other
Control Type:	Unsignalized
Intersection Capacity Utilization	69.1%
Analysis Period (min)	15
	ICU Level of Service C

Lanes, Volumes, Timings  
8: Old Redwood Hwy & Driveway 2

General Plan 2040 Project Altern. B Conditions  
Timing Plan: Saturday Midday Peak

												
Lane Group	EBL	EBT	EBR	WBL	WBT	WBR	NBL	NBT	NBR	SBL	SBT	SBR
Lane Configurations												
Traffic Volume (vph)	1	0	3	67	0	106	1	595	61	97	505	6
Future Volume (vph)	1	0	3	67	0	106	1	595	61	97	505	6
Ideal Flow (vphp)	1900	1900	1900	1900	1900	1900	1900	1900	1900	1900	1900	1900
Storage Length (ft)	0		0	0		0	0		100	50		0
Storage Lanes	0		0	1		0	0		1	1		0
Taper Length (ft)	25			25			25			25		
Lane Util. Factor	1.00	1.00	1.00	1.00	1.00	1.00	1.00	1.00	1.00	1.00	1.00	1.00
Ped Bike Factor												
Frt		0.902			0.850				0.850		0.998	
Flt Protected		0.987		0.950						0.950		
Satd. Flow (prot)	0	1658	0	1770	1583	0	0	1863	1583	1770	1859	0
Flt Permitted		0.987		0.950						0.950		
Satd. Flow (perm)	0	1658	0	1770	1583	0	0	1863	1583	1770	1859	0
Link Speed (mph)		30			30			45			45	
Link Distance (ft)		98			385			520			748	
Travel Time (s)		2.2			8.8			7.9			11.3	
Confl. Peds. (#/hr)							1		4	4		1
Confl. Bikes (#/hr)									3			9
Peak Hour Factor	0.38	0.38	0.38	1.00	1.00	1.00	0.94	0.94	0.94	0.93	0.93	0.93
Adj. Flow (vph)	3	0	8	67	0	106	1	633	65	104	543	6
Shared Lane Traffic (%)												
Lane Group Flow (vph)	0	11	0	67	106	0	0	634	65	104	549	0
Enter Blocked Intersection	No	No	No	No	No	No	No	No	No	No	No	No
Lane Alignment	Left	Left	Right	Left	Left	Right	Left	Left	Right	Left	Left	Right
Median Width(ft)		12			12			12			12	
Link Offset(ft)		0			0			0			0	
Crosswalk Width(ft)		16			16			16			16	
Two way Left Turn Lane												
Headway Factor	1.00	1.00	1.00	1.00	1.00	1.00	1.00	1.00	1.00	1.00	1.00	1.00
Turning Speed (mph)	15		9	15		9	15		9	15		9
Sign Control		Stop			Stop			Free			Free	
<b>Intersection Summary</b>												
Area Type:	Other											
Control Type:	Unsignalized											
Intersection Capacity Utilization	78.7%						ICU Level of Service D					
Analysis Period (min)	15											

Lanes, Volumes, Timings  
9: Driveway 3 & Shiloh Road

General Plan 2040 Project Altern. B Conditions

Timing Plan: Saturday Midday Peak

	→	↘	↙	←	↖	↗
Lane Group	EBT	EBR	WBL	WBT	NBL	NBR
Lane Configurations	↑	↗		↖	↘	↗
Traffic Volume (vph)	136	316	30	127	346	33
Future Volume (vph)	136	316	30	127	346	33
Ideal Flow (vphp)	1900	1900	1900	1900	1900	1900
Storage Length (ft)		200	0		0	0
Storage Lanes		1	0		1	1
Taper Length (ft)			25		25	
Lane Util. Factor	1.00	1.00	1.00	1.00	1.00	1.00
Ped Bike Factor						
Frt		0.850				0.850
Flt Protected				0.990	0.950	
Satd. Flow (prot)	1863	1583	0	1844	1770	1583
Flt Permitted				0.990	0.950	
Satd. Flow (perm)	1863	1583	0	1844	1770	1583
Link Speed (mph)	40			40	30	
Link Distance (ft)	2146			134	402	
Travel Time (s)	36.6			2.3	9.1	
Confl. Peds. (#/hr)		1				
Peak Hour Factor	0.88	0.88	0.80	0.80	1.00	1.00
Adj. Flow (vph)	155	359	38	159	346	33
Shared Lane Traffic (%)						
Lane Group Flow (vph)	155	359	0	197	346	33
Enter Blocked Intersection	No	No	No	No	No	No
Lane Alignment	Left	Right	Left	Left	Left	Right
Median Width(ft)	0			0	12	
Link Offset(ft)	0			0	0	
Crosswalk Width(ft)	16			16	16	
Two way Left Turn Lane						
Headway Factor	1.00	1.00	1.00	1.00	1.00	1.00
Turning Speed (mph)		9	15		15	9
Sign Control	Free			Free	Stop	
<b>Intersection Summary</b>						
Area Type:	Other					
Control Type:	Unsignalized					
Intersection Capacity Utilization	44.9%			ICU Level of Service A		
Analysis Period (min)	15					

Lanes, Volumes, Timings

General Plan 2040 Project Altern. B Conditions

10: US 101 NB Off Ramp/Lakewood Drive & Old Redwood Highway Timing Plan: Saturday Midday Peak



Lane Group	EBL	EBT	EBR	WBL	WBT	WBR	NBL	NBT	NBR	SBL	SBT	SBR
Lane Configurations												
Traffic Volume (vph)	372	467	0	0	718	357	415	393	185	316	0	908
Future Volume (vph)	372	467	0	0	718	357	415	393	185	316	0	908
Ideal Flow (vphpl)	1900	1900	1900	1900	1900	1900	1900	1900	1900	1900	1900	1900
Storage Length (ft)	155		0	0		0	270		150	120		0
Storage Lanes	1		0	0		0	1		1	1		1
Taper Length (ft)	50			25			165			75		
Lane Util. Factor	0.97	1.00	1.00	1.00	0.95	0.95	0.91	0.91	0.95	0.97	1.00	1.00
Ped Bike Factor	1.00				0.99			1.00		1.00		
Flt					0.950			0.958				0.850
Flt Protected	0.950						0.950	0.994		0.950		
Satd. Flow (prot)	3433	1863	0	0	3344	0	1610	3217	0	3433	0	1583
Flt Permitted	0.950						0.950	0.994		0.950		
Satd. Flow (perm)	3431	1863	0	0	3344	0	1610	3217	0	3431	0	1583
Right Turn on Red			Yes			Yes			Yes			Yes
Satd. Flow (RTOR)					100			61				241
Link Speed (mph)		35			35			30				30
Link Distance (ft)		226			617			716				478
Travel Time (s)		4.4			12.0			16.3				10.9
Confl. Peds. (#/hr)	2		1	1		2			1	1		
Confl. Bikes (#/hr)			10			3						
Peak Hour Factor	0.95	0.95	0.95	0.89	0.89	0.89	0.98	0.98	0.98	0.88	0.88	0.88
Adj. Flow (vph)	392	492	0	0	807	401	423	401	189	359	0	1032
Shared Lane Traffic (%)							20%					
Lane Group Flow (vph)	392	492	0	0	1208	0	338	675	0	359	0	1032
Enter Blocked Intersection	No	No	No	No	No	No	No	No	No	No	No	No
Lane Alignment	Left	Left	Right	Left	Left	Right	Left	Left	Right	Left	Left	Right
Median Width(ft)		24			24			24				24
Link Offset(ft)		0			0			0				0
Crosswalk Width(ft)		16			16			16				16
Two way Left Turn Lane												
Headway Factor	1.00	1.00	1.00	1.00	1.00	1.00	1.00	1.00	1.00	1.00	1.00	1.00
Turning Speed (mph)	15		9	15		9	15		9	15		9
Number of Detectors	1	2			2		1	2		1		1
Detector Template	Left	Thru			Thru		Left	Thru		Left		Right
Leading Detector (ft)	20	100			100		20	100		20		20
Trailing Detector (ft)	0	0			0		0	0		0		0
Detector 1 Position(ft)	0	0			0		0	0		0		0
Detector 1 Size(ft)	20	6			6		20	6		20		20
Detector 1 Type	Cl+Ex	Cl+Ex			Cl+Ex		Cl+Ex	Cl+Ex		Cl+Ex		Cl+Ex
Detector 1 Channel												
Detector 1 Extend (s)	0.0	0.0			0.0		0.0	0.0		0.0		0.0
Detector 1 Queue (s)	0.0	0.0			0.0		0.0	0.0		0.0		0.0
Detector 1 Delay (s)	0.0	0.0			0.0		0.0	0.0		0.0		0.0
Detector 2 Position(ft)		94			94			94				
Detector 2 Size(ft)		6			6			6				
Detector 2 Type		Cl+Ex			Cl+Ex			Cl+Ex				
Detector 2 Channel												
Detector 2 Extend (s)		0.0			0.0			0.0				

Lanes, Volumes, Timings

General Plan 2040 Project Altern. B Conditions

10: US 101 NB Off Ramp/Lakewood Drive & Old Redwood Highway Timing Plan: Saturday Midday Peak



Lane Group	EBL	EBT	EBR	WBL	WBT	WBR	NBL	NBT	NBR	SBL	SBT	SBR
Turn Type	Prot	NA			NA		Split	NA		Prot		pm+ov
Protected Phases	5	2			6		8	8		7		5
Permitted Phases												5 8
Detector Phase	5	2			6		8	8		7		5
Switch Phase												
Minimum Initial (s)	7.0	10.0			10.0		10.0	10.0		7.0		7.0
Minimum Split (s)	11.5	32.1			32.1		33.7	33.7		11.5		11.5
Total Split (s)	12.0	45.3			33.3		33.7	33.7		11.5		12.0
Total Split (%)	13.3%	50.1%			36.8%		37.2%	37.2%		12.7%		13.3%
Maximum Green (s)	7.5	40.8			28.8		29.2	29.2		7.0		7.5
Yellow Time (s)	3.5	3.5			3.5		3.5	3.5		3.5		3.5
All-Red Time (s)	1.0	1.0			1.0		1.0	1.0		1.0		1.0
Lost Time Adjust (s)	0.0	0.0			0.0		0.0	0.0		0.0		0.0
Total Lost Time (s)	4.5	4.5			4.5		4.5	4.5		4.5		4.5
Lead/Lag	Lead				Lag		Lag	Lag		Lead		Lead
Lead-Lag Optimize?	Yes				Yes		Yes	Yes		Yes		Yes
Vehicle Extension (s)	3.0	3.0			3.0		3.0	3.0		3.0		3.0
Recall Mode	None	Max			Max		None	None		None		None
Walk Time (s)		7.0			7.0		7.0	7.0				
Flash Don't Walk (s)		20.0			17.0		22.0	22.0				
Pedestrian Calls (#/hr)		0			0		0	0				
Act Effct Green (s)	7.5	41.0			28.9		24.7	24.7		7.0		36.7
Actuated g/C Ratio	0.09	0.48			0.34		0.29	0.29		0.08		0.43
v/c Ratio	1.31	0.56			1.02		0.73	0.70		1.29		1.27
Control Delay (s/veh)	195.7	20.1			58.8		37.9	28.9		188.2		152.3
Queue Delay	0.0	0.0			0.0		0.0	0.0		0.0		0.0
Total Delay (s/veh)	195.7	20.1			58.8		37.9	28.9		188.2		152.3
LOS	F	C			E		D	C		F		F
Approach Delay (s/veh)		98.0			58.8			31.9				161.6
Approach LOS		F			E			C				F

Intersection Summary

Area Type: Other  
 Cycle Length: 90.5  
 Actuated Cycle Length: 86.2  
 Natural Cycle: 110  
 Control Type: Actuated-Uncoordinated  
 Maximum v/c Ratio: 1.31  
 Intersection Signal Delay (s/veh): 92.2      Intersection LOS: F  
 Intersection Capacity Utilization 118.2%      ICU Level of Service H  
 Analysis Period (min) 15

Splits and Phases: 10: US 101 NB Off Ramp/Lakewood Drive & Old Redwood Highway

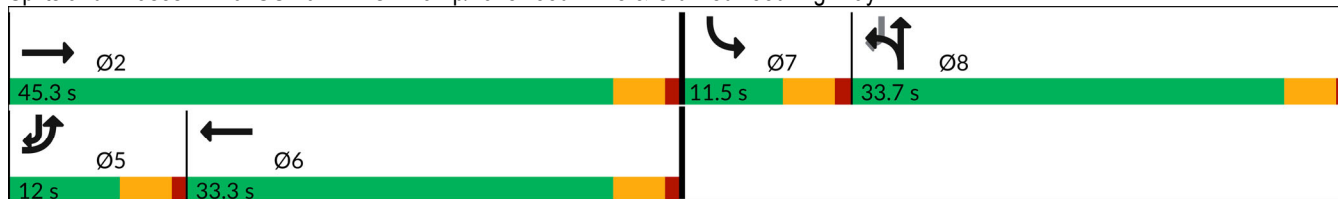

Lanes, Volumes, Timings  
 11: Old Redwood Highway & US 101 NB On Ramp

General Plan 2040 Project Altern. B Conditions  
 Timing Plan: Saturday Midday Peak



Lane Group	EBL	EBT	WBT	WBR	SBL	SBR
Lane Configurations						
Traffic Volume (vph)	112	845	1698	279	0	0
Future Volume (vph)	112	845	1698	279	0	0
Ideal Flow (vphpl)	1900	1900	1900	1900	1900	1900
Storage Length (ft)	245			0	0	0
Storage Lanes	1			0	0	0
Taper Length (ft)	50				25	
Lane Util. Factor	1.00	0.95	0.95	0.95	1.00	1.00
Ped Bike Factor						
Frt			0.979			
Flt Protected	0.950					
Satd. Flow (prot)	1770	3539	3465	0	0	0
Flt Permitted	0.950					
Satd. Flow (perm)	1770	3539	3465	0	0	0
Link Speed (mph)		35	35		30	
Link Distance (ft)		531	226		299	
Travel Time (s)		10.3	4.4		6.8	
Confl. Peds. (#/hr)	8			8		
Confl. Bikes (#/hr)				4		
Peak Hour Factor	0.96	0.96	0.92	0.92	0.25	0.25
Adj. Flow (vph)	117	880	1846	303	0	0
Shared Lane Traffic (%)						
Lane Group Flow (vph)	117	880	2149	0	0	0
Enter Blocked Intersection	No	No	No	No	No	No
Lane Alignment	Left	Left	Left	Right	Left	Right
Median Width(ft)		12	12		0	
Link Offset(ft)		0	0		0	
Crosswalk Width(ft)		16	16		16	
Two way Left Turn Lane						
Headway Factor	1.00	1.00	1.00	1.00	1.00	1.00
Turning Speed (mph)	15			9	15	9
Sign Control		Free	Free		Free	

**Intersection Summary**  
 Area Type: Other  
 Control Type: Unsignalized  
 Intersection Capacity Utilization 90.7% ICU Level of Service E  
 Analysis Period (min) 15

Lanes, Volumes, Timings

General Plan 2040 Project Altern. B Conditions

12: US 101 SB On Ramp/US 101 SB Off Ramp & Old Redwood Highway Timing Plan: Saturday Midday Peak



Lane Group	EBL	EBT	EBR	WBL	WBT	WBR	NBL	NBT	NBR	SBL	SBT	SBR
Lane Configurations		↑↑	↗	↖	↑↑					↖	↕	
Traffic Volume (vph)	0	713	543	632	1060	0	0	0	0	257	1	112
Future Volume (vph)	0	713	543	632	1060	0	0	0	0	257	1	112
Ideal Flow (vphpl)	1900	1900	1900	1900	1900	1900	1900	1900	1900	1900	1900	1900
Storage Length (ft)	0		0	250		0	0		0	420		0
Storage Lanes	0		1	0		0	0		0	1		0
Taper Length (ft)	25			165			25			75		
Lane Util. Factor	1.00	0.95	1.00	1.00	0.95	1.00	1.00	1.00	1.00	0.95	0.95	1.00
Ped Bike Factor			0.98	1.00								
Frt			0.850								0.905	
Flt Protected				0.950						0.950	0.982	
Satd. Flow (prot)	0	3539	1583	1770	3539	0	0	0	0	1681	1573	0
Flt Permitted				0.950						0.950	0.982	
Satd. Flow (perm)	0	3539	1553	1769	3539	0	0	0	0	1681	1573	0
Right Turn on Red			Yes			Yes			Yes			Yes
Satd. Flow (RTOR)			409								104	
Link Speed (mph)		35			35			30			30	
Link Distance (ft)		423			531			621			831	
Travel Time (s)		8.2			10.3			14.1			18.9	
Confl. Peds. (#/hr)	11		2	2		11						
Confl. Bikes (#/hr)			10			2						
Peak Hour Factor	0.97	0.97	0.97	0.96	0.96	0.96	0.25	0.25	0.25	0.72	0.72	0.72
Adj. Flow (vph)	0	735	560	658	1104	0	0	0	0	357	1	156
Shared Lane Traffic (%)										25%		
Lane Group Flow (vph)	0	735	560	658	1104	0	0	0	0	268	246	0
Enter Blocked Intersection	No	No	No	No	No	No	No	No	No	No	No	No
Lane Alignment	Left	Left	Right	Left	Left	Right	Left	Left	Right	Left	Left	Right
Median Width(ft)		24			24			12			12	
Link Offset(ft)		0			0			0			0	
Crosswalk Width(ft)		16			16			16			16	
Two way Left Turn Lane												
Headway Factor	1.00	1.00	1.00	1.00	1.00	1.00	1.00	1.00	1.00	1.00	1.00	1.00
Turning Speed (mph)	15		9	15		9	15		9	15		9
Number of Detectors		2	1	1	2					1	2	
Detector Template		Thru	Right	Left	Thru					Left	Thru	
Leading Detector (ft)		100	20	20	100					20	100	
Trailing Detector (ft)		0	0	0	0					0	0	
Detector 1 Position(ft)		0	0	0	0					0	0	
Detector 1 Size(ft)		6	20	20	6					20	6	
Detector 1 Type		Cl+Ex	Cl+Ex	Cl+Ex	Cl+Ex					Cl+Ex	Cl+Ex	
Detector 1 Channel												
Detector 1 Extend (s)		0.0	0.0	0.0	0.0					0.0	0.0	
Detector 1 Queue (s)		0.0	0.0	0.0	0.0					0.0	0.0	
Detector 1 Delay (s)		0.0	0.0	0.0	0.0					0.0	0.0	
Detector 2 Position(ft)		94			94						94	
Detector 2 Size(ft)		6			6						6	
Detector 2 Type		Cl+Ex			Cl+Ex						Cl+Ex	
Detector 2 Channel												
Detector 2 Extend (s)		0.0			0.0						0.0	



Lanes, Volumes, Timings

General Plan 2040 Project Altern. B Conditions

12: US 101 SB On Ramp/US 101 SB Off Ramp & Old Redwood Highway Timing Plan: Saturday Midday Peak



Lane Group	EBL	EBT	EBR	WBL	WBT	WBR	NBL	NBT	NBR	SBL	SBT	SBR
Turn Type		NA	Perm	Prot	NA					Perm	NA	
Protected Phases		6		5	2						8	
Permitted Phases			6							8		
Detector Phase		6	6	5	2					8	8	
Switch Phase												
Minimum Initial (s)		10.0	10.0	7.0	10.0					10.0	10.0	
Minimum Split (s)		32.1	32.1	11.5	38.1					14.7	14.7	
Total Split (s)		32.3	32.3	23.0	55.3					14.7	14.7	
Total Split (%)		46.1%	46.1%	32.9%	79.0%					21.0%	21.0%	
Maximum Green (s)		27.8	27.8	18.5	50.8					10.2	10.2	
Yellow Time (s)		3.5	3.5	3.5	3.5					3.5	3.5	
All-Red Time (s)		1.0	1.0	1.0	1.0					1.0	1.0	
Lost Time Adjust (s)		0.0	0.0	0.0	0.0					0.0	0.0	
Total Lost Time (s)		4.5	4.5	4.5	4.5					4.5	4.5	
Lead/Lag		Lag	Lag	Lead								
Lead-Lag Optimize?		Yes	Yes	Yes								
Vehicle Extension (s)		3.0	3.0	3.0	3.0					3.0	3.0	
Recall Mode		Max	Max	None	Max					None	None	
Walk Time (s)		7.0	7.0		7.0							
Flash Don't Walk (s)		20.0	20.0		25.0							
Pedestrian Calls (#/hr)		0	0		0							
Act Effct Green (s)		27.8	27.8	18.5	50.8					10.2	10.2	
Actuated g/C Ratio		0.40	0.40	0.26	0.73					0.15	0.15	
v/c Ratio		0.52	0.65	1.41	0.43					1.10	0.77	
Control Delay (s/veh)		17.7	8.7	222.1	4.4					119.2	35.2	
Queue Delay		0.0	0.0	0.0	0.0					0.0	0.0	
Total Delay (s/veh)		17.7	8.7	222.1	4.4					119.2	35.2	
LOS		B	A	F	A					F	D	
Approach Delay (s/veh)		13.8			85.7						79.0	
Approach LOS		B			F						E	

Intersection Summary

Area Type: Other  
 Cycle Length: 70  
 Actuated Cycle Length: 70  
 Natural Cycle: 90  
 Control Type: Actuated-Uncoordinated  
 Maximum v/c Ratio: 1.41  
 Intersection Signal Delay (s/veh): 58.7  
 Intersection LOS: E  
 Intersection Capacity Utilization 90.7%  
 ICU Level of Service E  
 Analysis Period (min) 15

Splits and Phases: 12: US 101 SB On Ramp/US 101 SB Off Ramp & Old Redwood Highway

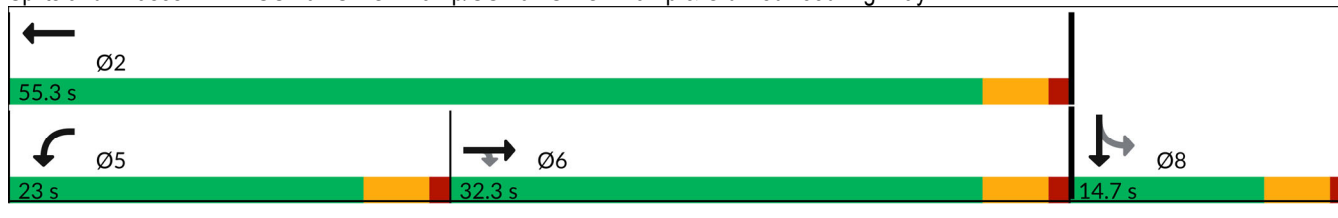























Appendix M – General Plan 2040 plus Alternative C Project  
Conditions Intersection Level of Service Worksheets

---

---

HCM 6th Signalized Intersection Summary  
1: Old Redwood Hwy & Shiloh Road

General Plan 2040 Project Altern. C Conditions  
Timing Plan: A.M. PEAK

												
Movement	EBL	EBT	EBR	WBL	WBT	WBR	NBL	NBT	NBR	SBL	SBT	SBR
Lane Configurations												
Traffic Volume (veh/h)	313	196	414	40	160	19	346	309	18	38	475	398
Future Volume (veh/h)	313	196	414	40	160	19	346	309	18	38	475	398
Initial Q (Qb), veh	0	0	0	0	0	0	0	0	0	0	0	0
Ped-Bike Adj(A_pbT)	1.00		1.00	1.00		1.00	1.00		1.00	1.00		0.98
Parking Bus, Adj	1.00	1.00	1.00	1.00	1.00	1.00	1.00	1.00	1.00	1.00	1.00	1.00
Work Zone On Approach		No			No			No			No	
Adj Sat Flow, veh/h/ln	1870	1870	1870	1870	1870	1870	1870	1870	1870	1870	1870	1870
Adj Flow Rate, veh/h	386	242	511	45	180	21	372	332	19	45	559	468
Peak Hour Factor	0.81	0.81	0.81	0.89	0.89	0.89	0.93	0.93	0.93	0.85	0.85	0.85
Percent Heavy Veh, %	2	2	2	2	2	2	2	2	2	2	2	2
Cap, veh/h	478	502	426	54	217	232	227	733	621	78	576	478
Arrive On Green	0.27	0.27	0.27	0.15	0.15	0.15	0.13	0.39	0.39	0.04	0.31	0.31
Sat Flow, veh/h	1781	1870	1585	370	1481	1585	1781	1870	1585	1781	1870	1551
Grp Volume(v), veh/h	386	242	511	225	0	21	372	332	19	45	559	468
Grp Sat Flow(s),veh/h/ln	1781	1870	1585	1852	0	1585	1781	1870	1585	1781	1870	1551
Q Serve(g_s), s	23.0	12.4	30.5	13.4	0.0	1.3	14.5	14.9	0.8	2.8	33.5	34.0
Cycle Q Clear(g_c), s	23.0	12.4	30.5	13.4	0.0	1.3	14.5	14.9	0.8	2.8	33.5	34.0
Prop In Lane	1.00		1.00	0.20		1.00	1.00		1.00	1.00		1.00
Lane Grp Cap(c), veh/h	478	502	426	271	0	232	227	733	621	78	576	478
V/C Ratio(X)	0.81	0.48	1.20	0.83	0.00	0.09	1.64	0.45	0.03	0.57	0.97	0.98
Avail Cap(c_a), veh/h	478	502	426	619	0	530	227	733	621	94	576	478
HCM Platoon Ratio	1.00	1.00	1.00	1.00	1.00	1.00	1.00	1.00	1.00	1.00	1.00	1.00
Upstream Filter(I)	1.00	1.00	1.00	1.00	0.00	1.00	1.00	1.00	1.00	1.00	1.00	1.00
Uniform Delay (d), s/veh	38.8	34.9	41.6	47.1	0.0	42.0	49.6	25.6	21.3	53.3	38.8	38.9
Incr Delay (d2), s/veh	9.9	0.7	111.0	6.5	0.0	0.2	305.4	0.4	0.0	6.5	30.0	35.7
Initial Q Delay(d3),s/veh	0.0	0.0	0.0	0.0	0.0	0.0	0.0	0.0	0.0	0.0	0.0	0.0
%ile BackOfQ(50%),veh/ln	11.0	5.6	24.5	6.5	0.0	0.5	25.5	6.4	0.3	1.4	19.5	17.1
Unsig. Movement Delay, s/veh												
LnGrp Delay(d),s/veh	48.7	35.6	152.5	53.6	0.0	42.1	355.0	26.0	21.3	59.7	68.7	74.6
LnGrp LOS	D	D	F	D	A	D	F	C	C	E	E	E
Approach Vol, veh/h		1139			246			723			1072	
Approach Delay, s/veh		92.5			52.7			195.1			70.9	
Approach LOS		F			D			F			E	
Timer - Assigned Phs		2	3	4		6	7	8				
Phs Duration (G+Y+Rc), s		35.0	18.0	39.5		21.1	8.5	49.0				
Change Period (Y+Rc), s		4.5	3.5	4.5		4.5	3.5	4.5				
Max Green Setting (Gmax), s		30.5	14.5	35.0		38.0	6.0	43.5				
Max Q Clear Time (g_c+I1), s		32.5	16.5	36.0		15.4	4.8	16.9				
Green Ext Time (p_c), s		0.0	0.0	0.0		1.2	0.0	1.8				
<b>Intersection Summary</b>												
HCM 6th Ctrl Delay			105.5									
HCM 6th LOS			F									

HCM 6th Signalized Intersection Summary  
2: Shiloh Road & Hembree Ln

General Plan 2040 Project Altern. C Conditions  
Timing Plan: A.M. PEAK



Movement	EBL	EBT	EBR	WBL	WBT	WBR	NBL	NBT	NBR	SBL	SBT	SBR
Lane Configurations	↔↔	↔		↔	↔↔		↔	↔			↔	↔
Traffic Volume (veh/h)	311	778	103	49	765	90	49	11	16	129	18	570
Future Volume (veh/h)	311	778	103	49	765	90	49	11	16	129	18	570
Initial Q (Qb), veh	0	0	0	0	0	0	0	0	0	0	0	0
Ped-Bike Adj(A_pbT)	1.00		1.00	1.00		1.00	1.00		1.00	1.00		1.00
Parking Bus, Adj	1.00	1.00	1.00	1.00	1.00	1.00	1.00	1.00	1.00	1.00	1.00	1.00
Work Zone On Approach		No			No			No			No	
Adj Sat Flow, veh/h/ln	1870	1870	1870	1870	1870	1870	1870	1870	1870	1870	1870	1870
Adj Flow Rate, veh/h	353	884	103	49	789	93	49	11	16	137	18	606
Peak Hour Factor	0.88	0.88	1.00	1.00	0.97	0.97	1.00	1.00	1.00	0.94	1.00	0.94
Percent Heavy Veh, %	2	2	2	2	2	2	2	2	2	2	2	2
Cap, veh/h	458	958	112	74	1573	185	91	35	51	198	26	408
Arrive On Green	0.13	0.58	0.58	0.04	0.49	0.49	0.05	0.05	0.05	0.12	0.12	0.12
Sat Flow, veh/h	3456	1644	192	1781	3202	377	1781	689	1002	1583	208	1585
Grp Volume(v), veh/h	353	0	987	49	438	444	49	0	27	155	0	606
Grp Sat Flow(s),veh/h/ln	1728	0	1836	1781	1777	1802	1781	0	1690	1791	0	1585
Q Serve(g_s), s	7.9	0.0	38.8	2.2	13.3	13.3	2.1	0.0	1.2	6.6	0.0	10.0
Cycle Q Clear(g_c), s	7.9	0.0	38.8	2.2	13.3	13.3	2.1	0.0	1.2	6.6	0.0	10.0
Prop In Lane	1.00		0.10	1.00		0.21	1.00		0.59	0.88		1.00
Lane Grp Cap(c), veh/h	458	0	1070	74	873	886	91	0	86	224	0	408
V/C Ratio(X)	0.77	0.00	0.92	0.66	0.50	0.50	0.54	0.00	0.31	0.69	0.00	1.48
Avail Cap(c_a), veh/h	734	0	1216	122	922	935	122	0	116	224	0	408
HCM Platoon Ratio	1.00	1.00	1.00	1.00	1.00	1.00	1.00	1.00	1.00	1.00	1.00	1.00
Upstream Filter(I)	1.00	0.00	1.00	1.00	1.00	1.00	1.00	0.00	1.00	1.00	0.00	1.00
Uniform Delay (d), s/veh	33.5	0.0	15.1	37.8	13.7	13.7	37.0	0.0	36.6	33.5	0.0	29.7
Incr Delay (d2), s/veh	2.8	0.0	10.8	9.8	0.4	0.4	4.9	0.0	2.0	8.8	0.0	230.5
Initial Q Delay(d3),s/veh	0.0	0.0	0.0	0.0	0.0	0.0	0.0	0.0	0.0	0.0	0.0	0.0
%ile BackOfQ(50%),veh/ln	3.3	0.0	15.9	1.1	4.7	4.8	1.0	0.0	0.5	3.3	0.0	33.6
Unsig. Movement Delay, s/veh												
LnGrp Delay(d),s/veh	36.3	0.0	25.9	47.5	14.2	14.2	42.0	0.0	38.7	42.3	0.0	260.2
LnGrp LOS	D	A	C	D	B	B	D	A	D	D	A	F
Approach Vol, veh/h		1340			931			76				761
Approach Delay, s/veh		28.6			15.9			40.8				215.8
Approach LOS		C			B			D				F
Timer - Assigned Phs	1	2		4	5	6		8				
Phs Duration (G+Y+Rc), s	7.3	50.6		14.0	14.6	43.3		8.1				
Change Period (Y+Rc), s	4.0	4.0		4.0	4.0	4.0		4.0				
Max Green Setting (Gmax), s	5.5	53.0		10.0	17.0	41.5		5.5				
Max Q Clear Time (g_c+I1), s	4.2	40.8		12.0	9.9	15.3		4.1				
Green Ext Time (p_c), s	0.0	5.8		0.0	0.7	5.7		0.0				
<b>Intersection Summary</b>												
HCM 6th Ctrl Delay				71.0								
HCM 6th LOS				E								

HCM 6th Signalized Intersection Summary  
 3: US 101 NB Off-Ramp & Shiloh Road

General Plan 2040 Project Altern. C Conditions  
 Timing Plan: A.M. PEAK



Movement	EBT	EBR	WBL	WBT	NBL	NBR
Lane Configurations	↑↑			↑	↘	↗
Traffic Volume (veh/h)	676	0	0	1037	813	517
Future Volume (veh/h)	676	0	0	1037	813	517
Initial Q (Qb), veh	0	0	0	0	0	0
Ped-Bike Adj(A_pbT)		1.00	1.00		1.00	1.00
Parking Bus, Adj	1.00	1.00	1.00	1.00	1.00	1.00
Work Zone On Approach	No			No	No	
Adj Sat Flow, veh/h/ln	1870	0	0	1870	1870	1870
Adj Flow Rate, veh/h	743	0	0	1152	1070	680
Peak Hour Factor	0.91	0.91	0.90	0.90	0.76	0.76
Percent Heavy Veh, %	2	0	0	2	2	2
Cap, veh/h	1629	0	0	857	767	1201
Arrive On Green	0.46	0.00	0.00	0.46	0.43	0.43
Sat Flow, veh/h	3741	0	0	1870	1781	2790
Grp Volume(v), veh/h	743	0	0	1152	1070	680
Grp Sat Flow(s),veh/h/ln	1777	0	0	1870	1781	1395
Q Serve(g_s), s	10.3	0.0	0.0	33.0	31.0	13.2
Cycle Q Clear(g_c), s	10.3	0.0	0.0	33.0	31.0	13.2
Prop In Lane		0.00	0.00		1.00	1.00
Lane Grp Cap(c), veh/h	1629	0	0	857	767	1201
V/C Ratio(X)	0.46	0.00	0.00	1.34	1.40	0.57
Avail Cap(c_a), veh/h	1629	0	0	857	767	1201
HCM Platoon Ratio	1.00	1.00	1.00	1.00	1.00	1.00
Upstream Filter(I)	1.00	0.00	0.00	1.00	1.00	1.00
Uniform Delay (d), s/veh	13.4	0.0	0.0	19.5	20.5	15.4
Incr Delay (d2), s/veh	0.2	0.0	0.0	162.5	185.7	0.6
Initial Q Delay(d3),s/veh	0.0	0.0	0.0	0.0	0.0	0.0
%ile BackOfQ(50%),veh/ln	3.6	0.0	0.0	50.5	51.0	3.9
Unsig. Movement Delay, s/veh						
LnGrp Delay(d),s/veh	13.6	0.0	0.0	182.0	206.2	16.1
LnGrp LOS	B	A	A	F	F	B
Approach Vol, veh/h	743			1152	1750	
Approach Delay, s/veh	13.6			182.0	132.3	
Approach LOS	B			F	F	
Timer - Assigned Phs		2			6	8
Phs Duration (G+Y+Rc), s		37.0			37.0	35.0
Change Period (Y+Rc), s		4.0			4.0	4.0
Max Green Setting (Gmax), s		33.0			33.0	31.0
Max Q Clear Time (g_c+I1), s		12.3			35.0	33.0
Green Ext Time (p_c), s		4.8			0.0	0.0
<b>Intersection Summary</b>						
HCM 6th Ctrl Delay			123.8			
HCM 6th LOS			F			

# HCM Signalized Intersection Capacity Analysis General Plan 2040 Project Altern. C Conditions

## 4: Shiloh Road & US 101 SB Off-Ramp

Timing Plan: A.M. PEAK



Movement	EBL	EBT	WBT	WBR	SBL	SBR
Lane Configurations		↑	↑		↘	↘
Traffic Volume (vph)	0	413	1146	0	263	184
Future Volume (vph)	0	413	1146	0	263	184
Ideal Flow (vphpl)	1900	1900	1900	1900	1900	1900
Total Lost time (s)		4.0	4.0		4.0	4.0
Lane Util. Factor		1.00	1.00		1.00	1.00
Frt		1.00	1.00		1.00	0.85
Flt Protected		1.00	1.00		0.95	1.00
Satd. Flow (prot)		1863	1863		1770	1583
Flt Permitted		1.00	1.00		0.95	1.00
Satd. Flow (perm)		1863	1863		1770	1583
Peak-hour factor, PHF	0.93	0.93	0.91	0.91	0.92	0.92
Adj. Flow (vph)	0	444	1259	0	286	200
RTOR Reduction (vph)	0	0	0	0	0	87
Lane Group Flow (vph)	0	444	1259	0	286	113
Turn Type		NA	NA		Perm	Perm
Protected Phases		2	6			
Permitted Phases					4	4
Actuated Green, G (s)		60.2	60.2		16.1	16.1
Effective Green, g (s)		60.2	60.2		16.1	16.1
Actuated g/C Ratio		0.71	0.71		0.19	0.19
Clearance Time (s)		4.0	4.0		4.0	4.0
Vehicle Extension (s)		3.0	3.0		3.0	3.0
Lane Grp Cap (vph)		1330	1330		338	302
v/s Ratio Prot		0.24	c0.68			
v/s Ratio Perm					c0.16	0.07
v/c Ratio		0.33	0.95		0.85	0.37
Uniform Delay, d1		4.5	10.6		32.9	29.7
Progression Factor		1.00	1.00		1.00	1.00
Incremental Delay, d2		0.1	13.8		17.4	0.8
Delay (s)		4.7	24.4		50.3	30.5
Level of Service		A	C		D	C
Approach Delay (s)		4.7	24.4		42.2	
Approach LOS		A	C		D	

Intersection Summary			
HCM 2000 Control Delay	24.4	HCM 2000 Level of Service	C
HCM 2000 Volume to Capacity ratio	0.93		
Actuated Cycle Length (s)	84.3	Sum of lost time (s)	8.0
Intersection Capacity Utilization	138.0%	ICU Level of Service	H
Analysis Period (min)	15		

c Critical Lane Group

Intersection						
Int Delay, s/veh	5.7					
Movement	EBT	EBR	WBL	WBT	NBL	NBR
Lane Configurations	↑↑		↖	↑	↖	↖
Traffic Vol, veh/h	891	14	130	1200	17	122
Future Vol, veh/h	891	14	130	1200	17	122
Conflicting Peds, #/hr	0	0	0	0	0	0
Sign Control	Free	Free	Free	Free	Stop	Stop
RT Channelized	-	None	-	None	-	None
Storage Length	-	-	68	-	0	0
Veh in Median Storage, #	0	-	-	0	0	-
Grade, %	0	-	-	0	0	-
Peak Hour Factor	96	96	87	87	84	84
Heavy Vehicles, %	2	2	2	2	2	2
Mvmt Flow	928	15	149	1379	20	145

Major/Minor	Major1	Major2	Minor1		
Conflicting Flow All	0	0	943	0	2613 472
Stage 1	-	-	-	-	936 -
Stage 2	-	-	-	-	1677 -
Critical Hdwy	-	-	4.13	-	6.63 6.93
Critical Hdwy Stg 1	-	-	-	-	5.83 -
Critical Hdwy Stg 2	-	-	-	-	5.43 -
Follow-up Hdwy	-	-	2.219	-	3.519 3.319
Pot Cap-1 Maneuver	-	-	725	-	23 539
Stage 1	-	-	-	-	343 -
Stage 2	-	-	-	-	166 -
Platoon blocked, %	-	-	-	-	-
Mov Cap-1 Maneuver	-	-	725	-	~ 18 539
Mov Cap-2 Maneuver	-	-	-	-	~ 18 -
Stage 1	-	-	-	-	343 -
Stage 2	-	-	-	-	132 -

Approach	EB	WB	NB
HCM Control Delay, s	0	1.1	79.9
HCM LOS			F

Minor Lane/Major Mvmt	NBLn1	NBLn2	EBT	EBR	WBL	WBT
Capacity (veh/h)	18	539	-	-	725	-
HCM Lane V/C Ratio	1.124	0.269	-	-	0.206	-
HCM Control Delay (s)	\$ 552.3	14.1	-	-	11.2	-
HCM Lane LOS	F	B	-	-	B	-
HCM 95th %tile Q(veh)	2.9	1.1	-	-	0.8	-

Notes  
 ~: Volume exceeds capacity    \$: Delay exceeds 300s    +: Computation Not Defined    \*: All major volume in platoon

HCM Signalized Intersection Capacity Analysis General Plan 2040 Project Altern. C Conditions  
 6: Conde Lane & Shiloh Road

Timing Plan: A.M. PEAK



Movement	EBL	EBT	EBR	WBL	WBT	WBR	NBL	NBT	NBR	SBL	SBT	SBR
Lane Configurations												
Traffic Volume (vph)	55	526	3	8	847	298	2	1	9	363	0	27
Future Volume (vph)	55	526	3	8	847	298	2	1	9	363	0	27
Ideal Flow (vphpl)	1900	1900	1900	1900	1900	1900	1900	1900	1900	1900	1900	1900
Total Lost time (s)	4.0	4.0		4.0	4.0			4.0			4.0	4.0
Lane Util. Factor	1.00	0.95		1.00	0.95			1.00			1.00	1.00
Frt	1.00	1.00		1.00	0.96			0.90			1.00	0.85
Flt Protected	0.95	1.00		0.95	1.00			0.99			0.95	1.00
Satd. Flow (prot)	1770	3536		1770	3401			1665			1770	1583
Flt Permitted	0.95	1.00		0.95	1.00			0.99			0.95	1.00
Satd. Flow (perm)	1770	3536		1770	3401			1665			1770	1583
Peak-hour factor, PHF	0.95	0.95	0.95	0.85	0.85	0.85	0.57	0.57	0.57	0.86	0.86	0.86
Adj. Flow (vph)	58	554	3	9	996	351	4	2	16	422	0	31
RTOR Reduction (vph)	0	0	0	0	23	0	0	15	0	0	0	0
Lane Group Flow (vph)	58	557	0	9	1324	0	0	7	0	0	422	31
Turn Type	Prot	NA		Prot	NA		Split	NA		Split	NA	custom
Protected Phases	5	2		1	6		7	7		4	4	
Permitted Phases												6
Actuated Green, G (s)	4.7	46.9		1.3	43.5			3.4			11.3	43.5
Effective Green, g (s)	4.7	46.9		1.3	43.5			3.4			11.3	43.5
Actuated g/C Ratio	0.06	0.59		0.02	0.55			0.04			0.14	0.55
Clearance Time (s)	4.0	4.0		4.0	4.0			4.0			4.0	4.0
Vehicle Extension (s)	3.0	3.0		3.0	3.0			3.0			3.0	3.0
Lane Grp Cap (vph)	105	2101		29	1875			71			253	872
v/s Ratio Prot	c0.03	c0.16		0.01	c0.39			c0.00			c0.24	
v/s Ratio Perm												0.02
v/c Ratio	0.55	0.26		0.31	0.71			0.09			1.67	0.04
Uniform Delay, d1	36.1	7.7		38.4	13.0			36.3			33.8	8.1
Progression Factor	1.00	1.00		1.00	1.00			1.00			1.00	1.00
Incremental Delay, d2	6.2	0.1		6.0	1.2			0.6			317.4	0.0
Delay (s)	42.2	7.8		44.4	14.2			36.8			351.2	8.1
Level of Service	D	A		D	B			D			F	A
Approach Delay (s)		11.0			14.4			36.8			327.7	
Approach LOS		B			B			D			F	
<b>Intersection Summary</b>												
HCM 2000 Control Delay			71.8									HCM 2000 Level of Service E
HCM 2000 Volume to Capacity ratio			0.82									
Actuated Cycle Length (s)			78.9								16.0	Sum of lost time (s)
Intersection Capacity Utilization			76.4%									ICU Level of Service D
Analysis Period (min)			15									

c Critical Lane Group



Intersection												
Int Delay, s/veh	2											
Movement	EBL	EBT	EBR	WBL	WBT	WBR	NBL	NBT	NBR	SBL	SBT	SBR
Lane Configurations		↕			↕		↕	↕			↕	
Traffic Vol, veh/h	12	208	64	5	86	0	42	0	3	1	0	24
Future Vol, veh/h	12	208	64	5	86	0	42	0	3	1	0	24
Conflicting Peds, #/hr	0	0	0	0	0	0	0	0	0	0	0	0
Sign Control	Free	Free	Free	Free	Free	Free	Stop	Stop	Stop	Stop	Stop	Stop
RT Channelized	-	-	None	-	-	None	-	-	None	-	-	None
Storage Length	-	-	-	-	-	-	0	-	-	-	-	-
Veh in Median Storage, #	-	0	-	-	0	-	-	0	-	-	0	-
Grade, %	-	0	-	-	0	-	-	0	-	-	0	-
Peak Hour Factor	91	91	91	85	85	85	100	100	100	71	71	71
Heavy Vehicles, %	2	2	2	2	2	2	2	2	2	2	2	2
Mvmt Flow	13	229	70	6	101	0	42	0	3	1	0	34

Major/Minor	Major1			Major2			Minor1			Minor2		
Conflicting Flow All	101	0	0	299	0	0	420	403	264	405	438	101
Stage 1	-	-	-	-	-	-	290	290	-	113	113	-
Stage 2	-	-	-	-	-	-	130	113	-	292	325	-
Critical Hdwy	4.12	-	-	4.12	-	-	7.12	6.52	6.22	7.12	6.52	6.22
Critical Hdwy Stg 1	-	-	-	-	-	-	6.12	5.52	-	6.12	5.52	-
Critical Hdwy Stg 2	-	-	-	-	-	-	6.12	5.52	-	6.12	5.52	-
Follow-up Hdwy	2.218	-	-	2.218	-	-	3.518	4.018	3.318	3.518	4.018	3.318
Pot Cap-1 Maneuver	1491	-	-	1262	-	-	544	536	775	556	512	954
Stage 1	-	-	-	-	-	-	718	672	-	892	802	-
Stage 2	-	-	-	-	-	-	874	802	-	716	649	-
Platoon blocked, %		-	-		-	-						
Mov Cap-1 Maneuver	1491	-	-	1262	-	-	518	527	775	547	504	954
Mov Cap-2 Maneuver	-	-	-	-	-	-	518	527	-	547	504	-
Stage 1	-	-	-	-	-	-	710	665	-	882	798	-
Stage 2	-	-	-	-	-	-	839	798	-	705	642	-

Approach	EB			WB			NB			SB		
HCM Control Delay, s	0.3			0.4			12.4			9		
HCM LOS							B			A		

Minor Lane/Major Mvmt	NBLn1	NBLn2	EBL	EBT	EBR	WBL	WBT	WBR	SBLn1
Capacity (veh/h)	518	775	1491	-	-	1262	-	-	926
HCM Lane V/C Ratio	0.081	0.004	0.009	-	-	0.005	-	-	0.038
HCM Control Delay (s)	12.6	9.7	7.4	0	-	7.9	0	-	9
HCM Lane LOS	B	A	A	A	-	A	A	-	A
HCM 95th %tile Q(veh)	0.3	0	0	-	-	0	-	-	0.1

Intersection												
Int Delay, s/veh	0.5											
Movement	EBL	EBT	EBR	WBL	WBT	WBR	NBL	NBT	NBR	SBL	SBT	SBR
Lane Configurations		↕		↕	↕			↕		↕	↕	
Traffic Vol, veh/h	1	0	0	6	0	10	0	662	9	15	914	0
Future Vol, veh/h	1	0	0	6	0	10	0	662	9	15	914	0
Conflicting Peds, #/hr	0	0	0	0	0	0	0	0	1	1	0	0
Sign Control	Stop	Stop	Stop	Stop	Stop	Stop	Free	Free	Free	Free	Free	Free
RT Channelized	-	-	None	-	-	None	-	-	None	-	-	None
Storage Length	-	-	-	0	-	-	-	-	-	50	-	-
Veh in Median Storage, #	-	0	-	-	0	-	-	0	-	-	0	-
Grade, %	-	0	-	-	0	-	-	0	-	-	0	-
Peak Hour Factor	25	25	25	100	100	100	99	99	99	90	90	90
Heavy Vehicles, %	2	2	2	2	2	2	2	2	2	2	2	2
Mvmt Flow	4	0	0	6	0	10	0	669	9	17	1016	0

Major/Minor	Minor2		Minor1		Major1		Major2					
Conflicting Flow All	1729	1729	1016	1725	1725	675	1016	0	0	679	0	0
Stage 1	1050	1050	-	675	675	-	-	-	-	-	-	-
Stage 2	679	679	-	1050	1050	-	-	-	-	-	-	-
Critical Hdwy	7.12	6.52	6.22	7.12	6.52	6.22	4.12	-	-	4.12	-	-
Critical Hdwy Stg 1	6.12	5.52	-	6.12	5.52	-	-	-	-	-	-	-
Critical Hdwy Stg 2	6.12	5.52	-	6.12	5.52	-	-	-	-	-	-	-
Follow-up Hdwy	3.518	4.018	3.318	3.518	4.018	3.318	2.218	-	-	2.218	-	-
Pot Cap-1 Maneuver	69	88	289	70	89	454	683	-	-	913	-	-
Stage 1	275	304	-	444	453	-	-	-	-	-	-	-
Stage 2	441	451	-	275	304	-	-	-	-	-	-	-
Platoon blocked, %								-	-	-	-	-
Mov Cap-1 Maneuver	67	86	289	69	87	454	683	-	-	912	-	-
Mov Cap-2 Maneuver	67	86	-	69	87	-	-	-	-	-	-	-
Stage 1	275	298	-	444	453	-	-	-	-	-	-	-
Stage 2	431	451	-	270	298	-	-	-	-	-	-	-

Approach	EB		WB		NB		SB	
HCM Control Delay, s	62.1		31.5		0		0.1	
HCM LOS	F		D					

Minor Lane/Major Mvmt	NBL	NBT	NBR	EBLn1	WBLn1	WBLn2	SBL	SBT	SBR
Capacity (veh/h)	683	-	-	67	69	454	912	-	-
HCM Lane V/C Ratio	-	-	-	0.06	0.087	0.022	0.018	-	-
HCM Control Delay (s)	0	-	-	62.1	62.1	13.1	9	-	-
HCM Lane LOS	A	-	-	F	F	B	A	-	-
HCM 95th %tile Q(veh)	0	-	-	0.2	0.3	0.1	0.1	-	-

Intersection						
Int Delay, s/veh	0					
Movement	EBT	EBR	WBL	WBT	NBL	NBR
Lane Configurations						
Traffic Vol, veh/h	210	0	0	82	0	0
Future Vol, veh/h	210	0	0	82	0	0
Conflicting Peds, #/hr	0	0	0	0	0	0
Sign Control	Free	Free	Free	Free	Stop	Stop
RT Channelized	-	None	-	None	-	None
Storage Length	-	-	-	-	0	0
Veh in Median Storage, #	0	-	-	0	0	-
Grade, %	0	-	-	0	0	-
Peak Hour Factor	85	85	81	81	25	25
Heavy Vehicles, %	2	2	2	2	2	2
Mvmt Flow	247	0	0	101	0	0

Major/Minor	Major1	Major2	Minor1			
Conflicting Flow All	0	0	247	0	348	247
Stage 1	-	-	-	-	247	-
Stage 2	-	-	-	-	101	-
Critical Hdwy	-	-	4.12	-	6.42	6.22
Critical Hdwy Stg 1	-	-	-	-	5.42	-
Critical Hdwy Stg 2	-	-	-	-	5.42	-
Follow-up Hdwy	-	-	2.218	-	3.518	3.318
Pot Cap-1 Maneuver	-	-	1319	-	649	792
Stage 1	-	-	-	-	794	-
Stage 2	-	-	-	-	923	-
Platoon blocked, %	-	-	-	-	-	-
Mov Cap-1 Maneuver	-	-	1319	-	649	792
Mov Cap-2 Maneuver	-	-	-	-	649	-
Stage 1	-	-	-	-	794	-
Stage 2	-	-	-	-	923	-

Approach	EB	WB	NB
HCM Control Delay, s	0	0	0
HCM LOS			A

Minor Lane/Major Mvmt	NBLn1	NBLn2	EBT	EBR	WBL	WBT
Capacity (veh/h)	-	-	-	-	1319	-
HCM Lane V/C Ratio	-	-	-	-	-	-
HCM Control Delay (s)	0	0	-	-	0	-
HCM Lane LOS	A	A	-	-	A	-
HCM 95th %tile Q(veh)	-	-	-	-	0	-

HCM 6th Signalized Intersection Summary      General Plan 2040 Project Altern. C Conditions  
 10: US 101 NB Off Ramp/Lakewood Drive & Old Redwood Highway      Timing Plan: A.M. PEAK



Movement	EBL	EBT	EBR	WBL	WBT	WBR	NBL	NBT	NBR	SBL	SBT	SBR
Lane Configurations	↔↔	↑			↑↑		↔	↔↔		↔↔		↔
Traffic Volume (veh/h)	264	619	0	0	656	156	224	255	92	255	0	679
Future Volume (veh/h)	264	619	0	0	656	156	224	255	92	255	0	679
Initial Q (Qb), veh	0	0	0	0	0	0	0	0	0	0	0	0
Ped-Bike Adj(A_pbT)	1.00		1.00	1.00		0.99	1.00		1.00	1.00		1.00
Parking Bus, Adj	1.00	1.00	1.00	1.00	1.00	1.00	1.00	1.00	1.00	1.00	1.00	1.00
Work Zone On Approach		No			No			No			No	
Adj Sat Flow, veh/h/ln	1870	1870	0	0	1870	1870	1870	1870	1870	1870	0	1870
Adj Flow Rate, veh/h	311	728	0	0	790	188	211	336	102	287	0	0
Peak Hour Factor	0.85	0.85	0.85	0.83	0.83	0.83	0.90	0.90	0.90	0.89	0.89	0.89
Percent Heavy Veh, %	2	2	0	0	2	2	2	2	2	2	0	2
Cap, veh/h	419	1202	0	0	1299	309	358	555	166	0	0	0
Arrive On Green	0.12	0.64	0.00	0.00	0.46	0.46	0.20	0.20	0.20	0.00	0.00	0.00
Sat Flow, veh/h	3456	1870	0	0	2933	676	1781	2764	825		0	
Grp Volume(v), veh/h	311	728	0	0	494	484	211	226	212		0.0	
Grp Sat Flow(s),veh/h/ln	1728	1870	0	0	1777	1738	1781	1870	1719			
Q Serve(g_s), s	5.4	14.2	0.0	0.0	13.1	13.1	6.7	6.9	7.1			
Cycle Q Clear(g_c), s	5.4	14.2	0.0	0.0	13.1	13.1	6.7	6.9	7.1			
Prop In Lane	1.00		0.00	0.00		0.39	1.00		0.48			
Lane Grp Cap(c), veh/h	419	1202	0	0	813	795	358	375	345			
V/C Ratio(X)	0.74	0.61	0.00	0.00	0.61	0.61	0.59	0.60	0.62			
Avail Cap(c_a), veh/h	497	1202	0	0	813	795	826	867	797			
HCM Platoon Ratio	1.00	1.00	1.00	1.00	1.00	1.00	1.00	1.00	1.00			
Upstream Filter(I)	1.00	1.00	0.00	0.00	1.00	1.00	1.00	1.00	1.00			
Uniform Delay (d), s/veh	26.5	6.5	0.0	0.0	12.8	12.8	22.7	22.7	22.8			
Incr Delay (d2), s/veh	4.9	2.3	0.0	0.0	3.4	3.4	1.6	1.5	1.8			
Initial Q Delay(d3),s/veh	0.0	0.0	0.0	0.0	0.0	0.0	0.0	0.0	0.0			
%ile BackOfQ(50%),veh/ln	2.4	4.5	0.0	0.0	5.1	5.0	2.8	3.0	2.8			
Unsig. Movement Delay, s/veh												
LnGrp Delay(d),s/veh	31.4	8.8	0.0	0.0	16.1	16.2	24.2	24.3	24.6			
LnGrp LOS	C	A	A	A	B	B	C	C	C			
Approach Vol, veh/h		1039			978			649				
Approach Delay, s/veh		15.6			16.2			24.4				
Approach LOS		B			B			C				
Timer - Assigned Phs		2			5	6		8				
Phs Duration (G+Y+Rc), s		45.3			11.6	33.7		17.3				
Change Period (Y+Rc), s		5.1			4.0	5.1		4.7				
Max Green Setting (Gmax), s		40.2			9.0	27.2		29.0				
Max Q Clear Time (g_c+I1), s		16.2			7.4	15.1		9.1				
Green Ext Time (p_c), s		5.3			0.2	4.9		3.2				

**Intersection Summary**

HCM 6th Ctrl Delay	17.9
HCM 6th LOS	B

**Notes**

User approved volume balancing among the lanes for turning movement.  
 Unsignalized Delay for [SBR] is excluded from calculations of the approach delay and intersection delay.

HCM 6th Signalized Intersection Summary      General Plan 2040 Project Altern. C Conditions  
 12: US 101 SB On Ramp/US 101 SB Off Ramp & Old Redwood Highway      Timing Plan: A.M. PEAK

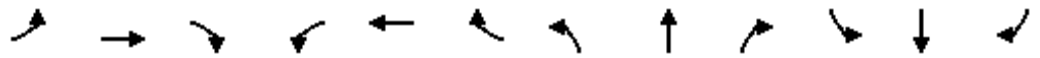

Movement	EBL	EBT	EBR	WBL	WBT	WBR	NBL	NBT	NBR	SBL	SBT	SBR
Lane Configurations		↑↑	↗	↘	↑↑					↘	↕	
Traffic Volume (veh/h)	0	699	814	559	742	0	0	0	0	166	0	144
Future Volume (veh/h)	0	699	814	559	742	0	0	0	0	166	0	144
Initial Q (Qb), veh	0	0	0	0	0	0				0	0	0
Ped-Bike Adj(A_pbT)	1.00		0.98	1.00		1.00				1.00		1.00
Parking Bus, Adj	1.00	1.00	1.00	1.00	1.00	1.00				1.00	1.00	1.00
Work Zone On Approach		No			No						No	
Adj Sat Flow, veh/h/ln	0	1870	1870	1870	1870	0				1870	1870	1870
Adj Flow Rate, veh/h	0	760	885	628	834	0				192	19	0
Peak Hour Factor	0.92	0.92	0.92	0.89	0.89	0.89				0.81	0.81	0.81
Percent Heavy Veh, %	0	2	2	2	2	0				2	2	2
Cap, veh/h	0	1208	530	646	2674	0				223	234	
Arrive On Green	0.00	0.34	0.34	0.36	0.75	0.00				0.13	0.13	0.00
Sat Flow, veh/h	0	3647	1560	1781	3647	0				1781	1870	0
Grp Volume(v), veh/h	0	760	885	628	834	0				192	19	0
Grp Sat Flow(s),veh/h/ln	0	1777	1560	1781	1777	0				1781	1870	0
Q Serve(g_s), s	0.0	14.4	27.2	27.8	6.1	0.0				8.5	0.7	0.0
Cycle Q Clear(g_c), s	0.0	14.4	27.2	27.8	6.1	0.0				8.5	0.7	0.0
Prop In Lane	0.00		1.00	1.00		0.00				1.00		0.00
Lane Grp Cap(c), veh/h	0	1208	530	646	2674	0				223	234	
V/C Ratio(X)	0.00	0.63	1.67	0.97	0.31	0.00				0.86	0.08	
Avail Cap(c_a), veh/h	0	1208	530	646	2674	0				223	234	
HCM Platoon Ratio	1.00	1.00	1.00	1.00	1.00	1.00				1.00	1.00	1.00
Upstream Filter(I)	0.00	1.00	1.00	1.00	1.00	0.00				1.00	1.00	0.00
Uniform Delay (d), s/veh	0.0	22.2	26.4	25.1	3.2	0.0				34.3	30.9	0.0
Incr Delay (d2), s/veh	0.0	2.5	309.2	28.5	0.3	0.0				27.5	0.1	0.0
Initial Q Delay(d3),s/veh	0.0	0.0	0.0	0.0	0.0	0.0				0.0	0.0	0.0
%ile BackOfQ(50%),veh/ln	0.0	6.0	54.8	15.8	1.4	0.0				5.3	0.3	0.0
Unsig. Movement Delay, s/veh												
LnGrp Delay(d),s/veh	0.0	24.7	335.6	53.7	3.5	0.0				61.8	31.1	0.0
LnGrp LOS	A	C	F	D	A	A				E	C	
Approach Vol, veh/h		1645			1462						211	
Approach Delay, s/veh		191.9			25.0						59.1	
Approach LOS		F			C						E	
Timer - Assigned Phs		2			5	6		8				
Phs Duration (G+Y+Rc), s		65.3			33.0	32.3		14.7				
Change Period (Y+Rc), s		5.1			4.0	5.1		4.7				
Max Green Setting (Gmax), s		60.2			29.0	27.2		10.0				
Max Q Clear Time (g_c+I1), s		8.1			29.8	29.2		10.5				
Green Ext Time (p_c), s		6.9			0.0	0.0		0.0				

**Intersection Summary**























HCM 6th Ctrl Delay	109.9
HCM 6th LOS	F

**Notes**

- User approved volume balancing among the lanes for turning movement.
- User approved ignoring U-Turning movement.
- Unsignalized Delay for [SBR] is excluded from calculations of the approach delay and intersection delay.

HCM 6th Signalized Intersection Summary  
 1: Old Redwood Hwy & Shiloh Road

General Plan 2040 Project Altern. C Conditions  
 Timing Plan: P.M. Peak

												
Movement	EBL	EBT	EBR	WBL	WBT	WBR	NBL	NBT	NBR	SBL	SBT	SBR
Lane Configurations												
Traffic Volume (veh/h)	317	188	586	44	198	38	611	559	44	51	538	265
Future Volume (veh/h)	317	188	586	44	198	38	611	559	44	51	538	265
Initial Q (Qb), veh	0	0	0	0	0	0	0	0	0	0	0	0
Ped-Bike Adj(A_pbT)	1.00		1.00	1.00		1.00	1.00		0.98	1.00		0.97
Parking Bus, Adj	1.00	1.00	1.00	1.00	1.00	1.00	1.00	1.00	1.00	1.00	1.00	1.00
Work Zone On Approach		No			No			No			No	
Adj Sat Flow, veh/h/ln	1870	1870	1870	1870	1870	1870	1870	1870	1870	1870	1870	1870
Adj Flow Rate, veh/h	327	194	604	48	218	42	657	601	47	55	578	285
Peak Hour Factor	0.97	0.97	0.97	0.91	0.91	0.91	0.93	0.93	0.93	0.93	0.93	0.93
Percent Heavy Veh, %	2	2	2	2	2	2	2	2	2	2	2	2
Cap, veh/h	464	488	412	57	260	270	221	702	581	85	559	462
Arrive On Green	0.26	0.26	0.26	0.17	0.17	0.17	0.12	0.38	0.38	0.05	0.30	0.30
Sat Flow, veh/h	1781	1870	1582	334	1519	1580	1781	1870	1547	1781	1870	1545
Grp Volume(v), veh/h	327	194	604	266	0	42	657	601	47	55	578	285
Grp Sat Flow(s),veh/h/ln	1781	1870	1582	1854	0	1580	1781	1870	1547	1781	1870	1545
Q Serve(g_s), s	19.5	10.0	30.5	16.3	0.0	2.6	14.5	34.6	2.3	3.6	35.0	18.6
Cycle Q Clear(g_c), s	19.5	10.0	30.5	16.3	0.0	2.6	14.5	34.6	2.3	3.6	35.0	18.6
Prop In Lane	1.00		1.00	0.18		1.00	1.00		1.00	1.00		1.00
Lane Grp Cap(c), veh/h	464	488	412	317	0	270	221	702	581	85	559	462
V/C Ratio(X)	0.70	0.40	1.46	0.84	0.00	0.16	2.98	0.86	0.08	0.65	1.03	0.62
Avail Cap(c_a), veh/h	464	488	412	602	0	513	221	702	581	91	559	462
HCM Platoon Ratio	1.00	1.00	1.00	1.00	1.00	1.00	1.00	1.00	1.00	1.00	1.00	1.00
Upstream Filter(I)	1.00	1.00	1.00	1.00	0.00	1.00	1.00	1.00	1.00	1.00	1.00	1.00
Uniform Delay (d), s/veh	39.2	35.7	43.3	46.9	0.0	41.3	51.3	33.6	23.5	54.8	41.0	35.2
Incr Delay (d2), s/veh	4.8	0.5	222.1	5.9	0.0	0.3	901.5	10.2	0.1	13.7	46.9	2.5
Initial Q Delay(d3),s/veh	0.0	0.0	0.0	0.0	0.0	0.0	0.0	0.0	0.0	0.0	0.0	0.0
%ile BackOfQ(50%),veh/ln	8.9	4.5	36.9	7.8	0.0	1.0	61.6	16.8	0.8	1.9	22.8	7.1
Unsig. Movement Delay, s/veh												
LnGrp Delay(d),s/veh	44.0	36.2	265.4	52.8	0.0	41.6	952.8	43.8	23.6	68.5	87.9	37.7
LnGrp LOS	D	D	F	D	A	D	F	D	C	E	F	D
Approach Vol, veh/h		1125			308			1305			918	
Approach Delay, s/veh		161.5			51.3			500.7			71.1	
Approach LOS		F			D			F			E	
Timer - Assigned Phs		2	3	4		6	7	8				
Phs Duration (G+Y+Rc), s		35.0	18.0	39.5		24.5	9.1	48.4				
Change Period (Y+Rc), s		4.5	3.5	4.5		4.5	3.5	4.5				
Max Green Setting (Gmax), s		30.5	14.5	35.0		38.0	6.0	43.5				
Max Q Clear Time (g_c+I1), s		32.5	16.5	37.0		18.3	5.6	36.6				
Green Ext Time (p_c), s		0.0	0.0	0.0		1.5	0.0	2.1				
<b>Intersection Summary</b>												
HCM 6th Ctrl Delay			250.6									
HCM 6th LOS			F									

HCM 6th Signalized Intersection Summary  
2: Shiloh Road & Hembree Ln

General Plan 2040 Project Altern. C Conditions  
Timing Plan: P.M. Peak



Movement	EBL	EBT	EBR	WBL	WBT	WBR	NBL	NBT	NBR	SBL	SBT	SBR
Lane Configurations	↔↔	↔		↔	↔↔		↔	↔			↔↔	↔
Traffic Volume (veh/h)	661	888	69	110	846	118	111	21	128	174	11	526
Future Volume (veh/h)	661	888	69	110	846	118	111	21	128	174	11	526
Initial Q (Qb), veh	0	0	0	0	0	0	0	0	0	0	0	0
Ped-Bike Adj(A_pbT)	1.00		1.00	1.00		1.00	1.00		1.00	1.00		1.00
Parking Bus, Adj	1.00	1.00	1.00	1.00	1.00	1.00	1.00	1.00	1.00	1.00	1.00	1.00
Work Zone On Approach		No			No			No			No	
Adj Sat Flow, veh/h/ln	1870	1870	1870	1870	1870	1870	1870	1870	1870	1870	1870	1870
Adj Flow Rate, veh/h	703	945	69	110	972	136	111	21	128	183	11	554
Peak Hour Factor	0.94	0.94	1.00	1.00	0.87	0.87	1.00	1.00	1.00	0.95	1.00	0.95
Percent Heavy Veh, %	2	2	2	2	2	2	2	2	2	2	2	2
Cap, veh/h	671	994	73	112	1396	195	112	14	87	192	12	489
Arrive On Green	0.19	0.58	0.58	0.06	0.45	0.45	0.06	0.06	0.06	0.11	0.11	0.11
Sat Flow, veh/h	3456	1722	126	1781	3130	438	1781	228	1392	1685	101	1585
Grp Volume(v), veh/h	703	0	1014	110	552	556	111	0	149	194	0	554
Grp Sat Flow(s),veh/h/ln	1728	0	1848	1781	1777	1791	1781	0	1620	1786	0	1585
Q Serve(g_s), s	17.0	0.0	45.0	5.4	21.8	21.9	5.5	0.0	5.5	9.4	0.0	10.0
Cycle Q Clear(g_c), s	17.0	0.0	45.0	5.4	21.8	21.9	5.5	0.0	5.5	9.4	0.0	10.0
Prop In Lane	1.00		0.07	1.00		0.24	1.00		0.86	0.94		1.00
Lane Grp Cap(c), veh/h	671	0	1067	112	792	799	112	0	102	204	0	489
V/C Ratio(X)	1.05	0.00	0.95	0.98	0.70	0.70	0.99	0.00	1.46	0.95	0.00	1.13
Avail Cap(c_a), veh/h	671	0	1119	112	842	849	112	0	102	204	0	489
HCM Platoon Ratio	1.00	1.00	1.00	1.00	1.00	1.00	1.00	1.00	1.00	1.00	1.00	1.00
Upstream Filter(I)	1.00	0.00	1.00	1.00	1.00	1.00	1.00	0.00	1.00	1.00	0.00	1.00
Uniform Delay (d), s/veh	35.3	0.0	17.3	41.0	19.5	19.5	41.0	0.0	41.0	38.5	0.0	30.3
Incr Delay (d2), s/veh	47.8	0.0	16.1	79.4	2.3	2.3	82.3	0.0	254.5	49.0	0.0	82.6
Initial Q Delay(d3),s/veh	0.0	0.0	0.0	0.0	0.0	0.0	0.0	0.0	0.0	0.0	0.0	0.0
%ile BackOfQ(50%),veh/ln	11.2	0.0	20.3	4.7	8.6	8.7	4.9	0.0	9.4	6.8	0.0	21.1
Unsig. Movement Delay, s/veh												
LnGrp Delay(d),s/veh	83.1	0.0	33.4	120.4	21.8	21.8	123.3	0.0	295.5	87.5	0.0	112.9
LnGrp LOS	F	A	C	F	C	C	F	A	F	F	A	F
Approach Vol, veh/h		1717			1218			260			748	
Approach Delay, s/veh		53.7			30.7			222.0			106.3	
Approach LOS		D			C			F			F	
Timer - Assigned Phs	1	2		4	5	6		8				
Phs Duration (G+Y+Rc), s	9.5	54.5		14.0	21.0	43.0		9.5				
Change Period (Y+Rc), s	4.0	4.0		4.0	4.0	4.0		4.0				
Max Green Setting (Gmax), s	5.5	53.0		10.0	17.0	41.5		5.5				
Max Q Clear Time (g_c+I1), s	7.4	47.0		12.0	19.0	23.9		7.5				
Green Ext Time (p_c), s	0.0	3.5		0.0	0.0	6.6		0.0				

Intersection Summary

HCM 6th Ctrl Delay	67.7
HCM 6th LOS	E

HCM 6th Signalized Intersection Summary  
3: US 101 NB Off-Ramp & Shiloh Road

General Plan 2040 Project Altern. C Conditions  
Timing Plan: P.M. Peak



Movement	EBT	EBR	WBL	WBT	NBL	NBR
Lane Configurations	↑↑			↑	↘	↗
Traffic Volume (veh/h)	792	0	0	919	694	783
Future Volume (veh/h)	792	0	0	919	694	783
Initial Q (Qb), veh	0	0	0	0	0	0
Ped-Bike Adj(A_pbT)		1.00	1.00		1.00	1.00
Parking Bus, Adj	1.00	1.00	1.00	1.00	1.00	1.00
Work Zone On Approach	No			No	No	
Adj Sat Flow, veh/h/ln	1870	0	0	1870	1870	1870
Adj Flow Rate, veh/h	843	0	0	947	771	870
Peak Hour Factor	0.94	0.94	0.97	0.97	0.90	0.90
Percent Heavy Veh, %	2	0	0	2	2	2
Cap, veh/h	1629	0	0	857	767	1201
Arrive On Green	0.46	0.00	0.00	0.46	0.43	0.43
Sat Flow, veh/h	3741	0	0	1870	1781	2790
Grp Volume(v), veh/h	843	0	0	947	771	870
Grp Sat Flow(s),veh/h/ln	1777	0	0	1870	1781	1395
Q Serve(g_s), s	12.1	0.0	0.0	33.0	31.0	18.6
Cycle Q Clear(g_c), s	12.1	0.0	0.0	33.0	31.0	18.6
Prop In Lane		0.00	0.00		1.00	1.00
Lane Grp Cap(c), veh/h	1629	0	0	857	767	1201
V/C Ratio(X)	0.52	0.00	0.00	1.10	1.01	0.72
Avail Cap(c_a), veh/h	1629	0	0	857	767	1201
HCM Platoon Ratio	1.00	1.00	1.00	1.00	1.00	1.00
Upstream Filter(I)	1.00	0.00	0.00	1.00	1.00	1.00
Uniform Delay (d), s/veh	13.8	0.0	0.0	19.5	20.5	17.0
Incr Delay (d2), s/veh	0.3	0.0	0.0	63.5	33.8	2.2
Initial Q Delay(d3),s/veh	0.0	0.0	0.0	0.0	0.0	0.0
%ile BackOfQ(50%),veh/ln	4.2	0.0	0.0	27.0	18.6	5.7
Unsig. Movement Delay, s/veh						
LnGrp Delay(d),s/veh	14.1	0.0	0.0	83.0	54.3	19.2
LnGrp LOS	B	A	A	F	F	B
Approach Vol, veh/h	843			947	1641	
Approach Delay, s/veh	14.1			83.0	35.7	
Approach LOS	B			F	D	
Timer - Assigned Phs		2			6	8
Phs Duration (G+Y+Rc), s		37.0			37.0	35.0
Change Period (Y+Rc), s		4.0			4.0	4.0
Max Green Setting (Gmax), s		33.0			33.0	31.0
Max Q Clear Time (g_c+I1), s		14.1			35.0	33.0
Green Ext Time (p_c), s		5.4			0.0	0.0
<b>Intersection Summary</b>						
HCM 6th Ctrl Delay			43.5			
HCM 6th LOS			D			



HCM Signalized Intersection Capacity Analysis General Plan 2040 Project Altern. C Conditions  
 4: Shiloh Road & US 101 SB Off-Ramp

Timing Plan: P.M. Peak



Movement	EBL	EBT	WBT	WBR	SBL	SBR
Lane Configurations		↑	↑		↙	↗
Traffic Volume (vph)	0	642	1064	0	348	94
Future Volume (vph)	0	642	1064	0	348	94
Ideal Flow (vphpl)	1900	1900	1900	1900	1900	1900
Total Lost time (s)		4.0	4.0		4.0	4.0
Lane Util. Factor		1.00	1.00		1.00	1.00
Frbp, ped/bikes		1.00	1.00		1.00	0.98
Flpb, ped/bikes		1.00	1.00		1.00	1.00
Frt		1.00	1.00		1.00	0.85
Flt Protected		1.00	1.00		0.95	1.00
Satd. Flow (prot)		1863	1863		1770	1548
Flt Permitted		1.00	1.00		0.95	1.00
Satd. Flow (perm)		1863	1863		1770	1548
Peak-hour factor, PHF	0.89	0.89	0.96	0.96	0.93	0.93
Adj. Flow (vph)	0	721	1108	0	374	101
RTOR Reduction (vph)	0	0	0	0	0	77
Lane Group Flow (vph)	0	721	1108	0	374	24
Confl. Peds. (#/hr)						1
Turn Type		NA	NA		Perm	Perm
Protected Phases		2	6			
Permitted Phases					4	4
Actuated Green, G (s)		49.4	49.4		17.6	17.6
Effective Green, g (s)		49.4	49.4		17.6	17.6
Actuated g/C Ratio		0.66	0.66		0.23	0.23
Clearance Time (s)		4.0	4.0		4.0	4.0
Vehicle Extension (s)		3.0	3.0		3.0	3.0
Lane Grp Cap (vph)		1227	1227		415	363
v/s Ratio Prot		0.39	c0.59			
v/s Ratio Perm					c0.21	0.02
v/c Ratio		0.59	0.90		0.90	0.07
Uniform Delay, d1		7.1	10.8		27.9	22.3
Progression Factor		1.00	1.00		1.00	1.00
Incremental Delay, d2		0.7	9.4		22.2	0.1
Delay (s)		7.9	20.2		50.0	22.4
Level of Service		A	C		D	C
Approach Delay (s)		7.9	20.2		44.2	
Approach LOS		A	C		D	
<b>Intersection Summary</b>						
HCM 2000 Control Delay			21.3		HCM 2000 Level of Service	C
HCM 2000 Volume to Capacity ratio			0.90			
Actuated Cycle Length (s)			75.0		Sum of lost time (s)	8.0
Intersection Capacity Utilization			154.8%		ICU Level of Service	H
Analysis Period (min)			15			
c Critical Lane Group						

Intersection						
Int Delay, s/veh	7.4					
Movement	EBT	EBR	WBL	WBT	NBL	NBR
Lane Configurations	↑↑		↖	↑	↖	↖
Traffic Vol, veh/h	1184	16	105	1123	18	159
Future Vol, veh/h	1184	16	105	1123	18	159
Conflicting Peds, #/hr	0	0	0	0	0	0
Sign Control	Free	Free	Free	Free	Stop	Stop
RT Channelized	-	None	-	None	-	None
Storage Length	-	-	68	-	0	0
Veh in Median Storage, #	0	-	-	0	0	-
Grade, %	0	-	-	0	0	-
Peak Hour Factor	89	89	92	92	89	89
Heavy Vehicles, %	2	2	2	2	2	2
Mvmt Flow	1330	18	114	1221	20	179

Major/Minor	Major1	Major2	Minor1		
Conflicting Flow All	0	0	1348	0	2788 674
Stage 1	-	-	-	-	1339 -
Stage 2	-	-	-	-	1449 -
Critical Hdwy	-	-	4.13	-	6.63 6.93
Critical Hdwy Stg 1	-	-	-	-	5.83 -
Critical Hdwy Stg 2	-	-	-	-	5.43 -
Follow-up Hdwy	-	-	2.219	-	3.519 3.319
Pot Cap-1 Maneuver	-	-	509	-	~ 18 398
Stage 1	-	-	-	-	210 -
Stage 2	-	-	-	-	215 -
Platoon blocked, %	-	-	-	-	-
Mov Cap-1 Maneuver	-	-	509	-	~ 14 398
Mov Cap-2 Maneuver	-	-	-	-	~ 14 -
Stage 1	-	-	-	-	210 -
Stage 2	-	-	-	-	167 -



















Approach	EB	WB	NB
HCM Control Delay, s	0	1.2	98.7
HCM LOS			F

Minor Lane/Major Mvmt	NBLn1	NBLn2	EBT	EBR	WBL	WBT
Capacity (veh/h)	14	398	-	-	509	-
HCM Lane V/C Ratio	1.445	0.449	-	-	0.224	-
HCM Control Delay (s)	\$ 783.1	21.2	-	-	14.1	-
HCM Lane LOS	F	C	-	-	B	-
HCM 95th %tile Q(veh)	3.2	2.3	-	-	0.9	-

Notes  
 ~: Volume exceeds capacity    \$: Delay exceeds 300s    +: Computation Not Defined    \*: All major volume in platoon

HCM Signalized Intersection Capacity Analysis General Plan 2040 Project Altern. C Conditions  
6: Conde Lane & Shiloh Road

Timing Plan: P.M. Peak

													
Movement	EBL	EBT	EBR	WBL	WBT	WBR	NBL	NBT	NBR	SBL	SBT	SBR	
Lane Configurations													
Traffic Volume (vph)	77	707	0	9	727	372	4	2	16	387	4	65	
Future Volume (vph)	77	707	0	9	727	372	4	2	16	387	4	65	
Ideal Flow (vphp)	1900	1900	1900	1900	1900	1900	1900	1900	1900	1900	1900	1900	
Total Lost time (s)	4.0	4.0		4.0	4.0			4.0			4.0	4.0	
Lane Util. Factor	1.00	0.95		1.00	0.95			1.00			1.00	1.00	
Frbp, ped/bikes	1.00	1.00		1.00	0.99			1.00			1.00	1.00	
Flpb, ped/bikes	1.00	1.00		1.00	1.00			1.00			1.00	1.00	
Frt	1.00	1.00		1.00	0.95			0.90			1.00	0.85	
Flt Protected	0.95	1.00		0.95	1.00			0.99			0.95	1.00	
Satd. Flow (prot)	1770	3539		1770	3336			1663			1775	1583	
Flt Permitted	0.95	1.00		0.95	1.00			0.99			0.95	1.00	
Satd. Flow (perm)	1770	3539		1770	3336			1663			1775	1583	
Peak-hour factor, PHF	0.88	0.88	0.88	0.80	0.80	0.80	0.63	0.63	0.63	0.88	0.88	0.88	
Adj. Flow (vph)	88	803	0	11	909	465	6	3	25	440	5	74	
RTOR Reduction (vph)	0	0	0	0	44	0	0	23	0	0	0	0	
Lane Group Flow (vph)	88	803	0	11	1330	0	0	11	0	0	445	74	
Confl. Peds. (#/hr)	1					1							
Turn Type	Prot	NA		Prot	NA		Split	NA		Split	NA	custom	
Protected Phases	5	2		1	6		7	7		4	4		
Permitted Phases												6	
Actuated Green, G (s)	6.6	49.4		1.4	44.2			5.4			11.2	44.2	
Effective Green, g (s)	6.6	49.4		1.4	44.2			5.4			11.2	44.2	
Actuated g/C Ratio	0.08	0.59		0.02	0.53			0.06			0.13	0.53	
Clearance Time (s)	4.0	4.0		4.0	4.0			4.0			4.0	4.0	
Vehicle Extension (s)	3.0	3.0		3.0	3.0			3.0			3.0	3.0	
Lane Grp Cap (vph)	140	2096		29	1768			107			238	838	
v/s Ratio Prot	c0.05	0.23		0.01	c0.40			c0.01			c0.25		
v/s Ratio Perm												0.05	
v/c Ratio	0.63	0.38		0.38	0.75			0.10			1.87	0.09	
Uniform Delay, d1	37.2	9.0		40.6	15.3			36.7			36.1	9.7	
Progression Factor	1.00	1.00		1.00	1.00			1.00			1.00	1.00	
Incremental Delay, d2	8.5	0.1		8.1	1.9			0.4			407.0	0.0	
Delay (s)	45.7	9.1		48.7	17.2			37.1			443.1	9.7	
Level of Service	D	A		D	B			D			F	A	
Approach Delay (s)		12.7			17.4			37.1			381.3		
Approach LOS		B			B			D			F		
<b>Intersection Summary</b>													
HCM 2000 Control Delay			82.9									HCM 2000 Level of Service	F
HCM 2000 Volume to Capacity ratio			0.87										
Actuated Cycle Length (s)			83.4									Sum of lost time (s)	16.0
Intersection Capacity Utilization			77.0%									ICU Level of Service	D
Analysis Period (min)			15										
c Critical Lane Group													

HCM 6th TWSC  
7: Entrance 1/Gridley Drive & Shiloh Road

General Plan 2040 Project Altern. C Conditions  
Timing Plan: P.M. Peak

Intersection												
Int Delay, s/veh	2.6											
Movement	EBL	EBT	EBR	WBL	WBT	WBR	NBL	NBT	NBR	SBL	SBT	SBR
Lane Configurations		↕			↕		↕	↕			↕	
Traffic Vol, veh/h	25	152	70	5	185	0	66	0	5	0	0	21
Future Vol, veh/h	25	152	70	5	185	0	66	0	5	0	0	21
Conflicting Peds, #/hr	1	0	0	0	0	0	0	0	0	0	0	0
Sign Control	Free	Free	Free	Free	Free	Free	Stop	Stop	Stop	Stop	Stop	Stop
RT Channelized	-	-	None	-	-	None	-	-	None	-	-	None
Storage Length	-	-	-	-	-	-	0	-	-	-	-	-
Veh in Median Storage, #	-	0	-	-	0	-	-	0	-	-	0	-
Grade, %	-	0	-	-	0	-	-	0	-	-	0	-
Peak Hour Factor	94	94	94	69	69	69	100	100	100	58	58	58
Heavy Vehicles, %	2	2	2	2	2	2	2	2	2	2	2	2
Mvmt Flow	27	162	74	7	268	0	66	0	5	0	0	36

Major/Minor	Major1			Major2			Minor1			Minor2		
Conflicting Flow All	269	0	0	236	0	0	553	536	199	539	573	269
Stage 1	-	-	-	-	-	-	253	253	-	283	283	-
Stage 2	-	-	-	-	-	-	300	283	-	256	290	-
Critical Hdwy	4.12	-	-	4.12	-	-	7.12	6.52	6.22	7.12	6.52	6.22
Critical Hdwy Stg 1	-	-	-	-	-	-	6.12	5.52	-	6.12	5.52	-
Critical Hdwy Stg 2	-	-	-	-	-	-	6.12	5.52	-	6.12	5.52	-
Follow-up Hdwy	2.218	-	-	2.218	-	-	3.518	4.018	3.318	3.518	4.018	3.318
Pot Cap-1 Maneuver	1295	-	-	1331	-	-	444	451	842	453	430	770
Stage 1	-	-	-	-	-	-	751	698	-	724	677	-
Stage 2	-	-	-	-	-	-	709	677	-	749	672	-
Platoon blocked, %		-	-		-	-						
Mov Cap-1 Maneuver	1294	-	-	1331	-	-	413	437	842	439	417	769
Mov Cap-2 Maneuver	-	-	-	-	-	-	413	437	-	439	417	-
Stage 1	-	-	-	-	-	-	733	681	-	706	672	-
Stage 2	-	-	-	-	-	-	672	672	-	727	656	-

Approach	EB			WB			NB			SB		
HCM Control Delay, s	0.8			0.2			15			9.9		
HCM LOS							C			A		

Minor Lane/Major Mvmt	NBLn1	NBLn2	EBL	EBT	EBR	WBL	WBT	WBR	SBLn1
Capacity (veh/h)	413	842	1294	-	-	1331	-	-	769
HCM Lane V/C Ratio	0.16	0.006	0.021	-	-	0.005	-	-	0.047
HCM Control Delay (s)	15.4	9.3	7.8	0	-	7.7	0	-	9.9
HCM Lane LOS	C	A	A	A	-	A	A	-	A
HCM 95th %tile Q(veh)	0.6	0	0.1	-	-	0	-	-	0.1

HCM 6th TWSC  
8: Old Redwood Hwy & Entrance 1

General Plan 2040 Project Altern. C Conditions  
Timing Plan: P.M. Peak

Intersection												
Int Delay, s/veh	3.4											
Movement	EBL	EBT	EBR	WBL	WBT	WBR	NBL	NBT	NBR	SBL	SBT	SBR
Lane Configurations		↕		↕	↕			↕		↕	↕	
Traffic Vol, veh/h	4	0	0	9	0	15	0	1195	10	16	1152	0
Future Vol, veh/h	4	0	0	9	0	15	0	1195	10	16	1152	0
Conflicting Peds, #/hr	0	0	0	0	0	0	0	0	0	0	0	0
Sign Control	Stop	Stop	Stop	Stop	Stop	Stop	Free	Free	Free	Free	Free	Free
RT Channelized	-	-	None	-	-	None	-	-	None	-	-	None
Storage Length	-	-	-	0	-	-	-	-	-	50	-	-
Veh in Median Storage, #	-	0	-	-	0	-	-	0	-	-	0	-
Grade, %	-	0	-	-	0	-	-	0	-	-	0	-
Peak Hour Factor	38	38	38	100	100	100	91	91	91	94	94	94
Heavy Vehicles, %	2	2	2	2	2	2	2	2	2	2	2	2
Mvmt Flow	11	0	0	9	0	15	0	1313	11	17	1226	0

Major/Minor	Minor2		Minor1		Major1		Major2					
Conflicting Flow All	2586	2584	1226	2579	2579	1319	1226	0	0	1324	0	0
Stage 1	1260	1260	-	1319	1319	-	-	-	-	-	-	-
Stage 2	1326	1324	-	1260	1260	-	-	-	-	-	-	-
Critical Hdwy	7.12	6.52	6.22	7.12	6.52	6.22	4.12	-	-	4.12	-	-
Critical Hdwy Stg 1	6.12	5.52	-	6.12	5.52	-	-	-	-	-	-	-
Critical Hdwy Stg 2	6.12	5.52	-	6.12	5.52	-	-	-	-	-	-	-
Follow-up Hdwy	3.518	4.018	3.318	3.518	4.018	3.318	2.218	-	-	2.218	-	-
Pot Cap-1 Maneuver	17	25	218	17	26	192	569	-	-	522	-	-
Stage 1	209	242	-	193	227	-	-	-	-	-	-	-
Stage 2	192	225	-	209	242	-	-	-	-	-	-	-
Platoon blocked, %	-	-	-	-	-	-	-	-	-	-	-	-
Mov Cap-1 Maneuver	15	24	218	17	25	192	569	-	-	522	-	-
Mov Cap-2 Maneuver	15	24	-	17	25	-	-	-	-	-	-	-
Stage 1	209	234	-	193	227	-	-	-	-	-	-	-
Stage 2	177	225	-	202	234	-	-	-	-	-	-	-

Approach	EB		WB		NB		SB	
HCM Control Delay, s	461.3		150.5		0		0.2	
HCM LOS	F		F					

Minor Lane/Major Mvmt	NBL	NBT	NBR	EBLn1	WBLn1	WBLn2	SBL	SBT	SBR
Capacity (veh/h)	569	-	-	15	17	192	522	-	-
HCM Lane V/C Ratio	-	-	-	0.702	0.529	0.078	0.033	-	-
HCM Control Delay (s)	0	-	-	\$ 461.3	\$ 359.2	25.3	12.1	-	-
HCM Lane LOS	A	-	-	F	F	D	B	-	-
HCM 95th %tile Q(veh)	0	-	-	1.7	1.4	0.3	0.1	-	-

Notes  
 ~: Volume exceeds capacity    \$: Delay exceeds 300s    +: Computation Not Defined    \*: All major volume in platoon

Intersection						
Int Delay, s/veh	0					
Movement	EBT	EBR	WBL	WBT	NBL	NBR
Lane Configurations	↔			↔	↔	↔
Traffic Vol, veh/h	125	0	0	169	0	0
Future Vol, veh/h	125	0	0	169	0	0
Conflicting Peds, #/hr	0	0	0	0	0	0
Sign Control	Free	Free	Free	Free	Stop	Stop
RT Channelized	-	None	-	None	-	None
Storage Length	-	-	-	-	0	0
Veh in Median Storage, #	0	-	-	0	0	-
Grade, %	0	-	-	0	0	-
Peak Hour Factor	92	92	68	68	100	100
Heavy Vehicles, %	2	2	2	2	2	2
Mvmt Flow	136	0	0	249	0	0

Major/Minor	Major1	Major2	Minor1		
Conflicting Flow All	0	0	136	0	385
Stage 1	-	-	-	-	136
Stage 2	-	-	-	-	249
Critical Hdwy	-	-	4.12	-	6.42
Critical Hdwy Stg 1	-	-	-	-	5.42
Critical Hdwy Stg 2	-	-	-	-	5.42
Follow-up Hdwy	-	-	2.218	-	3.518
Pot Cap-1 Maneuver	-	-	1448	-	618
Stage 1	-	-	-	-	890
Stage 2	-	-	-	-	792
Platoon blocked, %	-	-	-	-	-
Mov Cap-1 Maneuver	-	-	1448	-	618
Mov Cap-2 Maneuver	-	-	-	-	618
Stage 1	-	-	-	-	890
Stage 2	-	-	-	-	792

Approach	EB	WB	NB
HCM Control Delay, s	0	0	0
HCM LOS			A

Minor Lane/Major Mvmt	NBLn1	NBLn2	EBT	EBR	WBL	WBT
Capacity (veh/h)	-	-	-	-	1448	-
HCM Lane V/C Ratio	-	-	-	-	-	-
HCM Control Delay (s)	0	0	-	-	0	-
HCM Lane LOS	A	A	-	-	A	-
HCM 95th %tile Q(veh)	-	-	-	-	0	-

HCM 6th Signalized Intersection Summary      General Plan 2040 Project Altern. C Conditions  
 10: US 101 NB Off Ramp/Lakewood Drive & Old Redwood Highway      Timing Plan: P.M. Peak

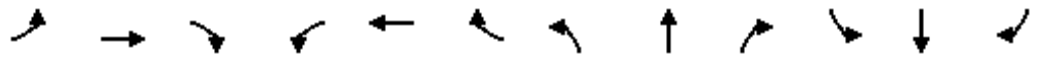

Movement	EBL	EBT	EBR	WBL	WBT	WBR	NBL	NBT	NBR	SBL	SBT	SBR
Lane Configurations	↔↔	↑			↑↑		↔	↔↔		↔↔		↔
Traffic Volume (veh/h)	309	682	0	0	724	270	528	539	303	386	0	618
Future Volume (veh/h)	309	682	0	0	724	270	528	539	303	386	0	618
Initial Q (Qb), veh	0	0	0	0	0	0	0	0	0	0	0	0
Ped-Bike Adj(A_pbT)	1.00		1.00	1.00		0.98	1.00		0.99	1.00		1.00
Parking Bus, Adj	1.00	1.00	1.00	1.00	1.00	1.00	1.00	1.00	1.00	1.00	1.00	1.00
Work Zone On Approach		No			No			No			No	
Adj Sat Flow, veh/h/ln	1870	1870	0	0	1870	1870	1870	1870	1870	1870	0	1870
Adj Flow Rate, veh/h	355	784	0	0	796	297	496	695	329	402	0	0
Peak Hour Factor	0.87	0.87	0.87	0.91	0.91	0.91	0.92	0.92	0.92	0.96	0.96	0.96
Percent Heavy Veh, %	2	2	0	0	2	2	2	2	2	2	0	2
Cap, veh/h	404	978	0	0	890	332	623	838	396	0	0	0
Arrive On Green	0.12	0.52	0.00	0.00	0.35	0.35	0.35	0.35	0.35	0.00	0.00	0.00
Sat Flow, veh/h	3456	1870	0	0	2611	938	1781	2394	1133		0	
Grp Volume(v), veh/h	355	784	0	0	562	531	496	543	481		0.0	
Grp Sat Flow(s),veh/h/ln	1728	1870	0	0	1777	1679	1781	1870	1657			
Q Serve(g_s), s	7.8	26.5	0.0	0.0	23.0	23.0	19.3	20.4	20.5			
Cycle Q Clear(g_c), s	7.8	26.5	0.0	0.0	23.0	23.0	19.3	20.4	20.5			
Prop In Lane	1.00		0.00	0.00		0.56	1.00		0.68			
Lane Grp Cap(c), veh/h	404	978	0	0	628	594	623	654	580			
V/C Ratio(X)	0.88	0.80	0.00	0.00	0.89	0.89	0.80	0.83	0.83			
Avail Cap(c_a), veh/h	404	978	0	0	628	594	672	705	625			
HCM Platoon Ratio	1.00	1.00	1.00	1.00	1.00	1.00	1.00	1.00	1.00			
Upstream Filter(I)	1.00	1.00	0.00	0.00	1.00	1.00	1.00	1.00	1.00			
Uniform Delay (d), s/veh	33.4	15.1	0.0	0.0	23.5	23.5	22.5	22.9	22.9			
Incr Delay (d2), s/veh	19.2	6.9	0.0	0.0	17.6	18.6	6.2	7.8	8.7			
Initial Q Delay(d3),s/veh	0.0	0.0	0.0	0.0	0.0	0.0	0.0	0.0	0.0			
%ile BackOfQ(50%),veh/ln	4.2	11.5	0.0	0.0	11.9	11.4	8.6	9.8	8.9			
Unsig. Movement Delay, s/veh												
LnGrp Delay(d),s/veh	52.6	22.0	0.0	0.0	41.1	42.1	28.8	30.7	31.6			
LnGrp LOS	D	C	A	A	D	D	C	C	C			
Approach Vol, veh/h		1139			1093			1520				
Approach Delay, s/veh		31.5			41.5			30.3				
Approach LOS		C			D			C				
Timer - Assigned Phs		2			5	6		8				
Phs Duration (G+Y+Rc), s		45.3			13.0	32.3		31.6				
Change Period (Y+Rc), s		5.1			4.0	5.1		4.7				
Max Green Setting (Gmax), s		40.2			9.0	27.2		29.0				
Max Q Clear Time (g_c+I1), s		28.5			9.8	25.0		22.5				
Green Ext Time (p_c), s		4.2			0.0	1.4		4.3				

**Intersection Summary**

HCM 6th Ctrl Delay	34.0
HCM 6th LOS	C

**Notes**

User approved volume balancing among the lanes for turning movement.  
 Unsignalized Delay for [SBR] is excluded from calculations of the approach delay and intersection delay.

HCM 6th Signalized Intersection Summary      General Plan 2040 Project Altern. C Conditions  
 12: US 101 SB On Ramp/US 101 SB Off Ramp & Old Redwood Highway      Timing Plan: P.M. Peak

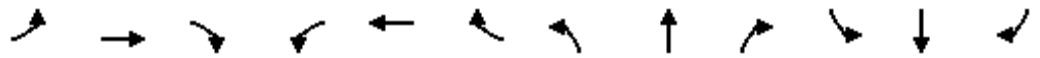

Movement	EBL	EBT	EBR	WBL	WBT	WBR	NBL	NBT	NBR	SBL	SBT	SBR
Lane Configurations		↑↑	↗	↘	↑↑					↘	↕	
Traffic Volume (veh/h)	0	612	501	443	1121	0	0	0	0	311	2	221
Future Volume (veh/h)	0	612	501	443	1121	0	0	0	0	311	2	221
Initial Q (Qb), veh	0	0	0	0	0	0				0	0	0
Ped-Bike Adj(A_pbT)	1.00		0.98	1.00		1.00				1.00		1.00
Parking Bus, Adj	1.00	1.00	1.00	1.00	1.00	1.00				1.00	1.00	1.00
Work Zone On Approach		No			No						No	
Adj Sat Flow, veh/h/ln	0	1870	1870	1870	1870	0				1870	1870	1870
Adj Flow Rate, veh/h	0	651	533	498	1260	0				322	77	0
Peak Hour Factor	0.94	0.94	0.94	0.89	0.89	0.89				0.83	0.83	0.83
Percent Heavy Veh, %	0	2	2	2	2	0				2	2	2
Cap, veh/h	0	1416	622	458	2533	0				262	275	
Arrive On Green	0.00	0.40	0.40	0.26	0.71	0.00				0.15	0.15	0.00
Sat Flow, veh/h	0	3647	1560	1781	3647	0				1781	1870	0
Grp Volume(v), veh/h	0	651	533	498	1260	0				322	77	0
Grp Sat Flow(s),veh/h/ln	0	1777	1560	1781	1777	0				1781	1870	0
Q Serve(g_s), s	0.0	9.4	21.8	18.0	11.0	0.0				10.3	2.6	0.0
Cycle Q Clear(g_c), s	0.0	9.4	21.8	18.0	11.0	0.0				10.3	2.6	0.0
Prop In Lane	0.00		1.00	1.00		0.00				1.00		0.00
Lane Grp Cap(c), veh/h	0	1416	622	458	2533	0				262	275	
V/C Ratio(X)	0.00	0.46	0.86	1.09	0.50	0.00				1.23	0.28	
Avail Cap(c_a), veh/h	0	1416	622	458	2533	0				262	275	
HCM Platoon Ratio	1.00	1.00	1.00	1.00	1.00	1.00				1.00	1.00	1.00
Upstream Filter(I)	0.00	1.00	1.00	1.00	1.00	0.00				1.00	1.00	0.00
Uniform Delay (d), s/veh	0.0	15.5	19.2	26.0	4.5	0.0				29.8	26.6	0.0
Incr Delay (d2), s/veh	0.0	1.1	14.2	67.7	0.7	0.0				131.7	0.5	0.0
Initial Q Delay(d3),s/veh	0.0	0.0	0.0	0.0	0.0	0.0				0.0	0.0	0.0
%ile BackOfQ(50%),veh/ln	0.0	3.6	9.4	15.6	2.6	0.0				13.8	1.1	0.0
Unsig. Movement Delay, s/veh												
LnGrp Delay(d),s/veh	0.0	16.6	33.5	93.7	5.2	0.0				161.5	27.1	0.0
LnGrp LOS	A	B	C	F	A	A				F	C	
Approach Vol, veh/h		1184			1758						399	
Approach Delay, s/veh		24.2			30.2						135.6	
Approach LOS		C			C						F	
Timer - Assigned Phs		2			5	6			8			
Phs Duration (G+Y+Rc), s		55.0			22.0	33.0			15.0			
Change Period (Y+Rc), s		5.1			4.0	5.1			4.7			
Max Green Setting (Gmax), s		49.9			18.0	27.9			10.3			
Max Q Clear Time (g_c+I1), s		13.0			20.0	23.8			12.3			
Green Ext Time (p_c), s		11.9			0.0	2.3			0.0			

**Intersection Summary**

HCM 6th Ctrl Delay	40.7
HCM 6th LOS	D

**Notes**

- User approved volume balancing among the lanes for turning movement.
- User approved ignoring U-Turning movement.
- Unsignalized Delay for [SBR] is excluded from calculations of the approach delay and intersection delay.



HCM 6th Signalized Intersection Summary  
1: Old Redwood Hwy & Shiloh Road

General Plan 2040 Project Altern. C Conditions  
Timing Plan: Saturday Midday Peak

Movement	EBL	EBT	EBR	WBL	WBT	WBR	NBL	NBT	NBR	SBL	SBT	SBR
Lane Configurations												
Traffic Volume (veh/h)	182	209	240	31	222	37	248	342	35	44	275	266
Future Volume (veh/h)	182	209	240	31	222	37	248	342	35	44	275	266
Initial Q (Qb), veh	0	0	0	0	0	0	0	0	0	0	0	0
Ped-Bike Adj(A_pbT)	1.00		0.97	1.00		1.00	1.00		0.98	1.00		0.97
Parking Bus, Adj	1.00	1.00	1.00	1.00	1.00	1.00	1.00	1.00	1.00	1.00	1.00	1.00
Work Zone On Approach		No			No			No			No	
Adj Sat Flow, veh/h/ln	1870	1870	1870	1870	1870	1870	1870	1870	1870	1870	1870	1870
Adj Flow Rate, veh/h	204	235	270	36	258	43	267	368	38	48	302	292
Peak Hour Factor	0.89	0.89	0.89	0.86	0.86	0.86	0.93	0.93	0.93	0.91	0.91	0.91
Percent Heavy Veh, %	2	2	2	2	2	2	2	2	2	2	2	2
Cap, veh/h	395	415	341	44	315	306	281	621	515	100	431	355
Arrive On Green	0.22	0.22	0.22	0.19	0.19	0.19	0.16	0.33	0.33	0.06	0.23	0.23
Sat Flow, veh/h	1781	1870	1537	228	1631	1585	1781	1870	1552	1781	1870	1541
Grp Volume(v), veh/h	204	235	270	294	0	43	267	368	38	48	302	292
Grp Sat Flow(s),veh/h/ln	1781	1870	1537	1859	0	1585	1781	1870	1552	1781	1870	1541
Q Serve(g_s), s	8.9	9.9	14.7	13.5	0.0	2.0	13.2	14.5	1.5	2.3	13.2	16.0
Cycle Q Clear(g_c), s	8.9	9.9	14.7	13.5	0.0	2.0	13.2	14.5	1.5	2.3	13.2	16.0
Prop In Lane	1.00		1.00	0.12		1.00	1.00		1.00	1.00		1.00
Lane Grp Cap(c), veh/h	395	415	341	359	0	306	281	621	515	100	431	355
V/C Ratio(X)	0.52	0.57	0.79	0.82	0.00	0.14	0.95	0.59	0.07	0.48	0.70	0.82
Avail Cap(c_a), veh/h	611	642	527	795	0	678	281	915	759	110	736	607
HCM Platoon Ratio	1.00	1.00	1.00	1.00	1.00	1.00	1.00	1.00	1.00	1.00	1.00	1.00
Upstream Filter(I)	1.00	1.00	1.00	1.00	0.00	1.00	1.00	1.00	1.00	1.00	1.00	1.00
Uniform Delay (d), s/veh	30.4	30.8	32.6	34.4	0.0	29.7	37.1	24.7	20.3	40.7	31.4	32.5
Incr Delay (d2), s/veh	1.0	1.2	4.5	4.6	0.0	0.2	40.7	0.9	0.1	3.5	2.1	4.8
Initial Q Delay(d3),s/veh	0.0	0.0	0.0	0.0	0.0	0.0	0.0	0.0	0.0	0.0	0.0	0.0
%ile BackOfQ(50%),veh/ln	3.8	4.4	5.6	6.3	0.0	0.7	8.6	6.1	0.5	1.1	5.9	6.1
Unsig. Movement Delay, s/veh												
LnGrp Delay(d),s/veh	31.4	32.0	37.1	39.0	0.0	30.0	77.8	25.6	20.4	44.2	33.5	37.2
LnGrp LOS	C	C	D	D	A	C	E	C	C	D	C	D
Approach Vol, veh/h		709			337			673			642	
Approach Delay, s/veh		33.8			37.9			46.0			36.0	
Approach LOS		C			D			D			D	
Timer - Assigned Phs		2	3	4		6	7	8				
Phs Duration (G+Y+Rc), s		24.2	18.0	25.0		21.7	9.0	34.0				
Change Period (Y+Rc), s		4.5	4.0	4.5		4.5	4.0	4.5				
Max Green Setting (Gmax), s		30.5	14.0	35.0		38.0	5.5	43.5				
Max Q Clear Time (g_c+I1), s		16.7	15.2	18.0		15.5	4.3	16.5				
Green Ext Time (p_c), s		2.5	0.0	2.5		1.7	0.0	2.2				
<b>Intersection Summary</b>												
HCM 6th Ctrl Delay			38.5									
HCM 6th LOS			D									

HCM 6th Signalized Intersection Summary  
 2: Shiloh Road & Hembree Ln

General Plan 2040 Project Altern. C Conditions  
 Timing Plan: Saturday Midday Peak

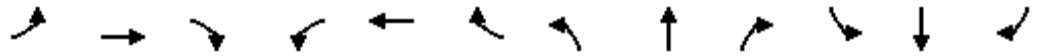

Movement	EBL	EBT	EBR	WBL	WBT	WBR	NBL	NBT	NBR	SBL	SBT	SBR
Lane Configurations												
Traffic Volume (veh/h)	918	500	69	110	442	235	111	21	128	236	11	856
Future Volume (veh/h)	918	500	69	110	442	235	111	21	128	236	11	856
Initial Q (Qb), veh	0	0	0	0	0	0	0	0	0	0	0	0
Ped-Bike Adj(A_pbT)	1.00		1.00	1.00		1.00	1.00		1.00	1.00		1.00
Parking Bus, Adj	1.00	1.00	1.00	1.00	1.00	1.00	1.00	1.00	1.00	1.00	1.00	1.00
Work Zone On Approach		No			No			No			No	
Adj Sat Flow, veh/h/ln	1870	1870	1870	1870	1870	1870	1870	1870	1870	1870	1870	1870
Adj Flow Rate, veh/h	977	532	69	110	460	245	111	21	128	259	11	941
Peak Hour Factor	0.94	0.94	1.00	1.00	0.96	0.96	1.00	1.00	1.00	0.91	1.00	0.91
Percent Heavy Veh, %	2	2	2	2	2	2	2	2	2	2	2	2
Cap, veh/h	864	742	96	140	643	340	144	18	113	252	11	630
Arrive On Green	0.25	0.46	0.46	0.08	0.29	0.29	0.08	0.08	0.08	0.15	0.15	0.15
Sat Flow, veh/h	3456	1622	210	1781	2245	1187	1781	228	1392	1712	73	1585
Grp Volume(v), veh/h	977	0	601	110	363	342	111	0	149	270	0	941
Grp Sat Flow(s),veh/h/ln	1728	0	1832	1781	1777	1655	1781	0	1620	1785	0	1585
Q Serve(g_s), s	17.0	0.0	18.0	4.1	12.5	12.6	4.2	0.0	5.5	10.0	0.0	10.0
Cycle Q Clear(g_c), s	17.0	0.0	18.0	4.1	12.5	12.6	4.2	0.0	5.5	10.0	0.0	10.0
Prop In Lane	1.00		0.11	1.00		0.72	1.00		0.86	0.96		1.00
Lane Grp Cap(c), veh/h	864	0	839	140	509	474	144	0	131	263	0	630
V/C Ratio(X)	1.13	0.00	0.72	0.78	0.71	0.72	0.77	0.00	1.14	1.03	0.00	1.49
Avail Cap(c_a), veh/h	864	0	1429	144	1085	1011	144	0	131	263	0	630
HCM Platoon Ratio	1.00	1.00	1.00	1.00	1.00	1.00	1.00	1.00	1.00	1.00	1.00	1.00
Upstream Filter(I)	1.00	0.00	1.00	1.00	1.00	1.00	1.00	0.00	1.00	1.00	0.00	1.00
Uniform Delay (d), s/veh	25.5	0.0	14.9	30.7	21.8	21.8	30.6	0.0	31.2	29.0	0.0	20.5
Incr Delay (d2), s/veh	73.1	0.0	1.2	23.6	1.9	2.1	22.0	0.0	120.0	63.0	0.0	230.8
Initial Q Delay(d3),s/veh	0.0	0.0	0.0	0.0	0.0	0.0	0.0	0.0	0.0	0.0	0.0	0.0
%ile BackOfQ(50%),veh/ln	15.0	0.0	6.4	2.6	4.9	4.6	2.6	0.0	6.4	8.6	0.0	49.2
Unsig. Movement Delay, s/veh												
LnGrp Delay(d),s/veh	98.6	0.0	16.0	54.3	23.6	23.9	52.7	0.0	151.2	92.0	0.0	251.3
LnGrp LOS	F	A	B	D	C	C	D	A	F	F	A	F
Approach Vol, veh/h		1578			815			260			1211	
Approach Delay, s/veh		67.2			27.9			109.2			215.8	
Approach LOS		E			C			F			F	
Timer - Assigned Phs	1	2		4	5	6		8				
Phs Duration (G+Y+Rc), s	9.4	35.1		14.0	21.0	23.5		9.5				
Change Period (Y+Rc), s	4.0	4.0		4.0	4.0	4.0		4.0				
Max Green Setting (Gmax), s	5.5	53.0		10.0	17.0	41.5		5.5				
Max Q Clear Time (g_c+I1), s	6.1	20.0		12.0	19.0	14.6		7.5				
Green Ext Time (p_c), s	0.0	4.2		0.0	0.0	4.5		0.0				

Intersection Summary		
HCM 6th Ctrl Delay		108.3
HCM 6th LOS		F

HCM 6th Signalized Intersection Summary  
3: US 101 NB Off-Ramp & Shiloh Road

General Plan 2040 Project Altern. C Conditions  
Timing Plan: Saturday Midday Peak



Movement	EBT	EBR	WBL	WBT	NBL	NBR
Lane Configurations	↑↑			↑	↵	↵↵
Traffic Volume (veh/h)	574	0	0	997	520	842
Future Volume (veh/h)	574	0	0	997	520	842
Initial Q (Qb), veh	0	0	0	0	0	0
Ped-Bike Adj(A_pbT)		1.00	1.00		1.00	1.00
Parking Bus, Adj	1.00	1.00	1.00	1.00	1.00	1.00
Work Zone On Approach	No			No	No	
Adj Sat Flow, veh/h/ln	1870	0	0	1870	1870	1870
Adj Flow Rate, veh/h	631	0	0	1120	547	886
Peak Hour Factor	0.91	0.91	0.89	0.89	0.95	0.95
Percent Heavy Veh, %	2	0	0	2	2	2
Cap, veh/h	1723	0	0	907	678	1062
Arrive On Green	0.48	0.00	0.00	0.48	0.38	0.38
Sat Flow, veh/h	3741	0	0	1870	1781	2790
Grp Volume(v), veh/h	631	0	0	1120	547	886
Grp Sat Flow(s),veh/h/ln	1777	0	0	1870	1781	1395
Q Serve(g_s), s	7.5	0.0	0.0	32.5	18.4	19.3
Cycle Q Clear(g_c), s	7.5	0.0	0.0	32.5	18.4	19.3
Prop In Lane		0.00	0.00		1.00	1.00
Lane Grp Cap(c), veh/h	1723	0	0	907	678	1062
V/C Ratio(X)	0.37	0.00	0.00	1.23	0.81	0.83
Avail Cap(c_a), veh/h	1723	0	0	907	811	1269
HCM Platoon Ratio	1.00	1.00	1.00	1.00	1.00	1.00
Upstream Filter(I)	1.00	0.00	0.00	1.00	1.00	1.00
Uniform Delay (d), s/veh	10.8	0.0	0.0	17.3	18.5	18.8
Incr Delay (d2), s/veh	0.1	0.0	0.0	115.3	5.1	4.2
Initial Q Delay(d3),s/veh	0.0	0.0	0.0	0.0	0.0	0.0
%ile BackOfQ(50%),veh/ln	2.4	0.0	0.0	40.1	7.8	6.2
Unsig. Movement Delay, s/veh						
LnGrp Delay(d),s/veh	10.9	0.0	0.0	132.6	23.7	23.1
LnGrp LOS	B	A	A	F	C	C
Approach Vol, veh/h	631			1120	1433	
Approach Delay, s/veh	10.9			132.6	23.3	
Approach LOS	B			F	C	
Timer - Assigned Phs		2			6	8
Phs Duration (G+Y+Rc), s		37.0			37.0	30.0
Change Period (Y+Rc), s		4.5			4.5	4.5
Max Green Setting (Gmax), s		32.5			32.5	30.5
Max Q Clear Time (g_c+I1), s		9.5			34.5	21.3
Green Ext Time (p_c), s		4.1			0.0	4.2
<b>Intersection Summary</b>						
HCM 6th Ctrl Delay			59.3			
HCM 6th LOS			E			

# HCM Signalized Intersection Capacity Analysis General Plan 2040 Project Altern. C Conditions

## 4: Shiloh Road & US 101 SB Off-Ramp

Timing Plan: Saturday Midday Peak

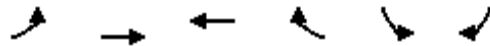

Movement	EBL	EBT	WBT	WBR	SBL	SBR
Lane Configurations		↑	↑		↘	↘
Traffic Volume (vph)	0	399	770	0	291	223
Future Volume (vph)	0	399	770	0	291	223
Ideal Flow (vphpl)	1900	1900	1900	1900	1900	1900
Total Lost time (s)		4.5	4.5		4.5	4.5
Lane Util. Factor		1.00	1.00		1.00	1.00
Frbp, ped/bikes		1.00	1.00		1.00	1.00
Flpb, ped/bikes		1.00	1.00		1.00	1.00
Frt		1.00	1.00		1.00	0.85
Flt Protected		1.00	1.00		0.95	1.00
Satd. Flow (prot)		1863	1863		1770	1583
Flt Permitted		1.00	1.00		0.95	1.00
Satd. Flow (perm)		1863	1863		1770	1583
Peak-hour factor, PHF	0.96	0.96	0.96	0.96	0.68	0.68
Adj. Flow (vph)	0	416	802	0	428	328
RTOR Reduction (vph)	0	0	0	0	0	176
Lane Group Flow (vph)	0	416	802	0	428	152
Confl. Bikes (#/hr)				2		
Turn Type		NA	NA		Perm	Perm
Protected Phases		2	6			
Permitted Phases					4	4
Actuated Green, G (s)		29.3	29.3		16.9	16.9
Effective Green, g (s)		29.3	29.3		16.9	16.9
Actuated g/C Ratio		0.53	0.53		0.31	0.31
Clearance Time (s)		4.5	4.5		4.5	4.5
Vehicle Extension (s)		3.0	3.0		3.0	3.0
Lane Grp Cap (vph)		988	988		541	484
v/s Ratio Prot		0.22	c0.43			
v/s Ratio Perm					c0.24	0.10
v/c Ratio		0.42	0.81		0.79	0.31
Uniform Delay, d1		7.8	10.7		17.5	14.7
Progression Factor		1.00	1.00		1.00	1.00
Incremental Delay, d2		0.3	5.2		7.8	0.4
Delay (s)		8.1	15.8		25.3	15.1
Level of Service		A	B		C	B
Approach Delay (s)		8.1	15.8		20.9	
Approach LOS		A	B		C	
<b>Intersection Summary</b>						
HCM 2000 Control Delay			16.1		HCM 2000 Level of Service	B
HCM 2000 Volume to Capacity ratio			0.80			
Actuated Cycle Length (s)			55.2		Sum of lost time (s)	9.0
Intersection Capacity Utilization			133.4%		ICU Level of Service	H
Analysis Period (min)			15			
c Critical Lane Group						

Intersection						
Int Delay, s/veh	5.3					
Movement	EBT	EBR	WBL	WBT	NBL	NBR
Lane Configurations	↑↑		↖	↑	↖	↖
Traffic Vol, veh/h	801	30	120	887	24	115
Future Vol, veh/h	801	30	120	887	24	115
Conflicting Peds, #/hr	0	0	0	0	1	0
Sign Control	Free	Free	Free	Free	Stop	Stop
RT Channelized	-	None	-	None	-	None
Storage Length	-	-	68	-	0	0
Veh in Median Storage, #	0	-	-	0	0	-
Grade, %	0	-	-	0	0	-
Peak Hour Factor	92	92	87	87	78	78
Heavy Vehicles, %	2	2	2	2	2	2
Mvmt Flow	871	33	138	1020	31	147



















Major/Minor	Major1	Major2	Minor1		
Conflicting Flow All	0	0	904	0	2185 452
Stage 1	-	-	-	-	888 -
Stage 2	-	-	-	-	1297 -
Critical Hdwy	-	-	4.13	-	6.63 6.93
Critical Hdwy Stg 1	-	-	-	-	5.83 -
Critical Hdwy Stg 2	-	-	-	-	5.43 -
Follow-up Hdwy	-	-	2.219	-	3.519 3.319
Pot Cap-1 Maneuver	-	-	750	-	44 556
Stage 1	-	-	-	-	363 -
Stage 2	-	-	-	-	255 -
Platoon blocked, %	-	-	-	-	-
Mov Cap-1 Maneuver	-	-	750	-	36 556
Mov Cap-2 Maneuver	-	-	-	-	36 -
Stage 1	-	-	-	-	363 -
Stage 2	-	-	-	-	208 -

Approach	EB	WB	NB
HCM Control Delay, s	0	1.3	58.2
HCM LOS			F

Minor Lane/Major Mvmt	NBLn1	NBLn2	EBT	EBR	WBL	WBT
Capacity (veh/h)	36	556	-	-	750	-
HCM Lane V/C Ratio	0.855	0.265	-	-	0.184	-
HCM Control Delay (s)	271.1	13.8	-	-	10.9	-
HCM Lane LOS	F	B	-	-	B	-
HCM 95th %tile Q(veh)	3.1	1.1	-	-	0.7	-

HCM Signalized Intersection Capacity Analysis General Plan 2040 Project Altern. C Conditions  
 6: Conde Lane & Shiloh Road

Timing Plan: Saturday Midday Peak

												
Movement	EBL	EBT	EBR	WBL	WBT	WBR	NBL	NBT	NBR	SBL	SBT	SBR
Lane Configurations												
Traffic Volume (vph)	43	529	1	13	590	301	1	0	9	291	0	41
Future Volume (vph)	43	529	1	13	590	301	1	0	9	291	0	41
Ideal Flow (vphpl)	1900	1900	1900	1900	1900	1900	1900	1900	1900	1900	1900	1900
Total Lost time (s)	4.5	4.5		4.5	4.5			4.5			4.5	4.5
Lane Util. Factor	1.00	0.95		1.00	0.95			1.00			1.00	1.00
Frbp, ped/bikes	1.00	1.00		1.00	0.99			1.00			1.00	1.00
Flpb, ped/bikes	1.00	1.00		1.00	1.00			1.00			1.00	1.00
Frt	1.00	1.00		1.00	0.95			0.88			1.00	0.85
Flt Protected	0.95	1.00		0.95	1.00			0.99			0.95	1.00
Satd. Flow (prot)	1770	3538		1770	3335			1630			1770	1583
Flt Permitted	0.95	1.00		0.95	1.00			0.99			0.95	1.00
Satd. Flow (perm)	1770	3538		1770	3335			1630			1770	1583
Peak-hour factor, PHF	0.96	0.96	0.96	0.91	0.91	0.91	0.58	0.58	0.58	0.78	0.78	0.78
Adj. Flow (vph)	45	551	1	14	648	331	2	0	16	373	0	53
RTOR Reduction (vph)	0	0	0	0	54	0	0	17	0	0	0	0
Lane Group Flow (vph)	45	552	0	14	925	0	0	1	0	0	373	53
Confl. Bikes (#/hr)							2					
Turn Type	Prot	NA		Prot	NA		Split	NA		Split	NA	custom
Protected Phases	5	2		1	6		7	7		4	4	
Permitted Phases												6
Actuated Green, G (s)	4.1	29.8		1.1	26.8			2.8			12.6	26.8
Effective Green, g (s)	4.1	29.8		1.1	26.8			2.8			12.6	26.8
Actuated g/C Ratio	0.06	0.46		0.02	0.42			0.04			0.20	0.42
Clearance Time (s)	4.5	4.5		4.5	4.5			4.5			4.5	4.5
Vehicle Extension (s)	3.0	3.0		3.0	3.0			3.0			3.0	3.0
Lane Grp Cap (vph)	112	1639		30	1390			70			346	659
v/s Ratio Prot	c0.03	c0.16		0.01	c0.28			c0.00			c0.21	
v/s Ratio Perm												0.03
v/c Ratio	0.40	0.34		0.47	0.67			0.01			1.08	0.08
Uniform Delay, d1	28.9	11.0		31.3	15.1			29.4			25.8	11.3
Progression Factor	1.00	1.00		1.00	1.00			1.00			1.00	1.00
Incremental Delay, d2	2.4	0.1		11.0	1.2			0.1			70.8	0.1
Delay (s)	31.3	11.1		42.4	16.4			29.5			96.6	11.4
Level of Service	C	B		D	B			C			F	B
Approach Delay (s)		12.6			16.7			29.5			86.0	
Approach LOS		B			B			C			F	
<b>Intersection Summary</b>												
HCM 2000 Control Delay			30.1									HCM 2000 Level of Service C
HCM 2000 Volume to Capacity ratio			0.71									
Actuated Cycle Length (s)			64.3								18.0	
Intersection Capacity Utilization			66.0%									ICU Level of Service C
Analysis Period (min)			15									
c Critical Lane Group												

Intersection												
Int Delay, s/veh	4.4											
Movement	EBL	EBT	EBR	WBL	WBT	WBR	NBL	NBT	NBR	SBL	SBT	SBR
Lane Configurations		↕			↕		↕	↕			↕	
Traffic Vol, veh/h	30	157	118	8	135	0	133	0	9	0	0	27
Future Vol, veh/h	30	157	118	8	135	0	133	0	9	0	0	27
Conflicting Peds, #/hr	1	0	0	0	0	0	0	0	0	0	0	0
Sign Control	Free	Free	Free	Free	Free	Free	Stop	Stop	Stop	Stop	Stop	Stop
RT Channelized	-	-	None	-	-	None	-	-	None	-	-	None
Storage Length	-	-	-	-	-	-	0	-	-	-	-	-
Veh in Median Storage, #	-	0	-	-	0	-	-	0	-	-	0	-
Grade, %	-	0	-	-	0	-	-	0	-	-	0	-
Peak Hour Factor	93	93	93	88	88	88	100	100	100	56	56	56
Heavy Vehicles, %	2	2	2	2	2	2	2	2	2	2	2	2
Mvmt Flow	32	169	127	9	153	0	133	0	9	0	0	48

Major/Minor	Major1			Major2			Minor1			Minor2		
Conflicting Flow All	154	0	0	296	0	0	492	469	233	473	532	154
Stage 1	-	-	-	-	-	-	297	297	-	172	172	-
Stage 2	-	-	-	-	-	-	195	172	-	301	360	-
Critical Hdwy	4.12	-	-	4.12	-	-	7.12	6.52	6.22	7.12	6.52	6.22
Critical Hdwy Stg 1	-	-	-	-	-	-	6.12	5.52	-	6.12	5.52	-
Critical Hdwy Stg 2	-	-	-	-	-	-	6.12	5.52	-	6.12	5.52	-
Follow-up Hdwy	2.218	-	-	2.218	-	-	3.518	4.018	3.318	3.518	4.018	3.318
Pot Cap-1 Maneuver	1426	-	-	1265	-	-	487	492	806	501	453	892
Stage 1	-	-	-	-	-	-	712	668	-	830	756	-
Stage 2	-	-	-	-	-	-	807	756	-	708	626	-
Platoon blocked, %		-	-		-	-						
Mov Cap-1 Maneuver	1425	-	-	1265	-	-	449	474	806	482	437	891
Mov Cap-2 Maneuver	-	-	-	-	-	-	449	474	-	482	437	-
Stage 1	-	-	-	-	-	-	693	650	-	807	749	-
Stage 2	-	-	-	-	-	-	757	749	-	681	609	-

Approach	EB			WB			NB			SB		
HCM Control Delay, s	0.7			0.4			16			9.3		
HCM LOS							C			A		

Minor Lane/Major Mvmt	NBLn1	NBLn2	EBL	EBT	EBR	WBL	WBT	WBR	SBLn1
Capacity (veh/h)	449	806	1425	-	-	1265	-	-	891
HCM Lane V/C Ratio	0.296	0.011	0.023	-	-	0.007	-	-	0.054
HCM Control Delay (s)	16.4	9.5	7.6	0	-	7.9	0	-	9.3
HCM Lane LOS	C	A	A	A	-	A	A	-	A
HCM 95th %tile Q(veh)	1.2	0	0.1	-	-	0	-	-	0.2

HCM 6th TWSC  
8: Old Redwood Hwy & Entrance 1

General Plan 2040 Project Altern. C Conditions  
Timing Plan: Saturday Midday Peak

Intersection												
Int Delay, s/veh	1.2											
Movement	EBL	EBT	EBR	WBL	WBT	WBR	NBL	NBT	NBR	SBL	SBT	SBR
Lane Configurations		↕		↗	↘			↕		↗	↘	
Traffic Vol, veh/h	1	0	3	19	0	30	1	595	17	27	505	6
Future Vol, veh/h	1	0	3	19	0	30	1	595	17	27	505	6
Conflicting Peds, #/hr	0	0	0	0	0	0	1	0	4	4	0	1
Sign Control	Stop	Stop	Stop	Stop	Stop	Stop	Free	Free	Free	Free	Free	Free
RT Channelized	-	-	None	-	-	None	-	-	None	-	-	None
Storage Length	-	-	-	0	-	-	-	-	-	50	-	-
Veh in Median Storage, #	-	0	-	-	0	-	-	0	-	-	0	-
Grade, %	-	0	-	-	0	-	-	0	-	-	0	-
Peak Hour Factor	38	38	38	100	100	100	94	94	94	93	93	93
Heavy Vehicles, %	2	2	2	2	2	2	2	2	2	2	2	2
Mvmt Flow	3	0	8	19	0	30	1	633	18	29	543	6

Major/Minor	Minor2		Minor1		Major1		Major2					
Conflicting Flow All	1264	1262	547	1256	1256	646	550	0	0	655	0	0
Stage 1	605	605	-	648	648	-	-	-	-	-	-	-
Stage 2	659	657	-	608	608	-	-	-	-	-	-	-
Critical Hdwy	7.12	6.52	6.22	7.12	6.52	6.22	4.12	-	-	4.12	-	-
Critical Hdwy Stg 1	6.12	5.52	-	6.12	5.52	-	-	-	-	-	-	-
Critical Hdwy Stg 2	6.12	5.52	-	6.12	5.52	-	-	-	-	-	-	-
Follow-up Hdwy	3.518	4.018	3.318	3.518	4.018	3.318	2.218	-	-	2.218	-	-
Pot Cap-1 Maneuver	146	170	537	148	171	472	1020	-	-	932	-	-
Stage 1	485	487	-	459	466	-	-	-	-	-	-	-
Stage 2	453	462	-	483	486	-	-	-	-	-	-	-
Platoon blocked, %								-	-	-	-	-
Mov Cap-1 Maneuver	133	164	536	142	165	470	1019	-	-	928	-	-
Mov Cap-2 Maneuver	133	164	-	142	165	-	-	-	-	-	-	-
Stage 1	484	471	-	456	463	-	-	-	-	-	-	-
Stage 2	423	459	-	461	470	-	-	-	-	-	-	-

Approach	EB		WB		NB		SB	
HCM Control Delay, s	17.2		21.3		0		0.5	
HCM LOS	C		C					

Minor Lane/Major Mvmt	NBL	NBT	NBR	EBLn1	WBLn1	WBLn2	SBL	SBT	SBR
Capacity (veh/h)	1019	-	-	305	142	470	928	-	-
HCM Lane V/C Ratio	0.001	-	-	0.035	0.134	0.064	0.031	-	-
HCM Control Delay (s)	8.5	0	-	17.2	34.2	13.2	9	-	-
HCM Lane LOS	A	A	-	C	D	B	A	-	-
HCM 95th %tile Q(veh)	0	-	-	0.1	0.5	0.2	0.1	-	-



Intersection						
Int Delay, s/veh	0					
Movement	EBT	EBR	WBL	WBT	NBL	NBR
Lane Configurations	↔			↔	↔	↔
Traffic Vol, veh/h	145	0	0	135	0	0
Future Vol, veh/h	145	0	0	135	0	0
Conflicting Peds, #/hr	0	1	0	0	0	0
Sign Control	Free	Free	Free	Free	Stop	Stop
RT Channelized	-	None	-	None	-	None
Storage Length	-	-	-	-	0	0
Veh in Median Storage, #	0	-	-	0	0	-
Grade, %	0	-	-	0	0	-
Peak Hour Factor	88	88	80	80	100	100
Heavy Vehicles, %	2	2	2	2	2	2
Mvmt Flow	165	0	0	169	0	0

Major/Minor	Major1	Major2	Minor1		
Conflicting Flow All	0	0	166	0	335
Stage 1	-	-	-	-	166
Stage 2	-	-	-	-	169
Critical Hdwy	-	-	4.12	-	6.42
Critical Hdwy Stg 1	-	-	-	-	5.42
Critical Hdwy Stg 2	-	-	-	-	5.42
Follow-up Hdwy	-	-	2.218	-	3.518
Pot Cap-1 Maneuver	-	-	1412	-	660
Stage 1	-	-	-	-	863
Stage 2	-	-	-	-	861
Platoon blocked, %	-	-	-	-	-
Mov Cap-1 Maneuver	-	-	1411	-	659
Mov Cap-2 Maneuver	-	-	-	-	659
Stage 1	-	-	-	-	862
Stage 2	-	-	-	-	861

Approach	EB	WB	NB
HCM Control Delay, s	0	0	0
HCM LOS			A

Minor Lane/Major Mvmt	NBLn1	NBLn2	EBT	EBR	WBL	WBT
Capacity (veh/h)	-	-	-	-	1411	-
HCM Lane V/C Ratio	-	-	-	-	-	-
HCM Control Delay (s)	0	0	-	-	0	-
HCM Lane LOS	A	A	-	-	A	-
HCM 95th %tile Q(veh)	-	-	-	-	0	-

HCM 6th Signalized Intersection Summary      General Plan 2040 Project Altern. C Conditions  
 10: US 101 NB Off Ramp/Lakewood Drive & Old Redwood Highway      Timing Plan: Saturday Midday Peak

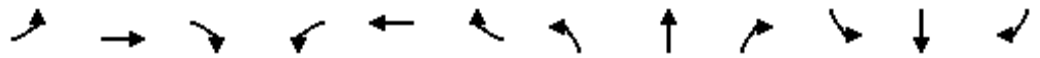

Movement	EBL	EBT	EBR	WBL	WBT	WBR	NBL	NBT	NBR	SBL	SBT	SBR
Lane Configurations	↔↔	↑			↑↑		↔	↔↔		↔↔		↔
Traffic Volume (veh/h)	372	423	0	0	670	357	415	393	185	316	0	908
Future Volume (veh/h)	372	423	0	0	670	357	415	393	185	316	0	908
Initial Q (Qb), veh	0	0	0	0	0	0	0	0	0	0	0	0
Ped-Bike Adj(A_pbT)	1.00		1.00	1.00		0.98	1.00		1.00	1.00		1.00
Parking Bus, Adj	1.00	1.00	1.00	1.00	1.00	1.00	1.00	1.00	1.00	1.00	1.00	1.00
Work Zone On Approach		No			No			No			No	
Adj Sat Flow, veh/h/ln	1870	1870	0	0	1870	1870	1870	1870	1870	1870	0	1870
Adj Flow Rate, veh/h	392	445	0	0	753	401	338	520	189	359	0	0
Peak Hour Factor	0.95	0.95	0.95	0.89	0.89	0.89	0.98	0.98	0.98	0.88	0.88	0.88
Percent Heavy Veh, %	2	2	0	0	2	2	2	2	2	2	0	2
Cap, veh/h	374	1101	0	0	927	492	501	737	267	0	0	0
Arrive On Green	0.11	0.59	0.00	0.00	0.42	0.42	0.28	0.28	0.28	0.00	0.00	0.00
Sat Flow, veh/h	3456	1870	0	0	2323	1183	1781	2621	948		0	
Grp Volume(v), veh/h	392	445	0	0	600	554	338	370	339		0.0	
Grp Sat Flow(s),veh/h/ln	1728	1870	0	0	1777	1636	1781	1870	1699			
Q Serve(g_s), s	7.5	8.9	0.0	0.0	20.6	20.8	11.7	12.3	12.4			
Cycle Q Clear(g_c), s	7.5	8.9	0.0	0.0	20.6	20.8	11.7	12.3	12.4			
Prop In Lane	1.00		0.00	0.00		0.72	1.00		0.56			
Lane Grp Cap(c), veh/h	374	1101	0	0	738	680	501	526	478			
V/C Ratio(X)	1.05	0.40	0.00	0.00	0.81	0.82	0.67	0.70	0.71			
Avail Cap(c_a), veh/h	374	1101	0	0	738	680	751	788	716			
HCM Platoon Ratio	1.00	1.00	1.00	1.00	1.00	1.00	1.00	1.00	1.00			
Upstream Filter(I)	1.00	1.00	0.00	0.00	1.00	1.00	1.00	1.00	1.00			
Uniform Delay (d), s/veh	30.9	7.7	0.0	0.0	17.9	17.9	22.1	22.3	22.3			
Incr Delay (d2), s/veh	59.7	1.1	0.0	0.0	9.5	10.4	1.6	1.7	1.9			
Initial Q Delay(d3),s/veh	0.0	0.0	0.0	0.0	0.0	0.0	0.0	0.0	0.0			
%ile BackOfQ(50%),veh/ln	6.0	3.1	0.0	0.0	9.3	8.8	4.8	5.3	4.9			
Unsig. Movement Delay, s/veh												
LnGrp Delay(d),s/veh	90.6	8.8	0.0	0.0	27.3	28.3	23.7	24.0	24.3			
LnGrp LOS	F	A	A	A	C	C	C	C	C			
Approach Vol, veh/h		837			1154			1047				
Approach Delay, s/veh		47.1			27.8			24.0				
Approach LOS		D			C			C				
Timer - Assigned Phs		2			5	6		8				
Phs Duration (G+Y+Rc), s		45.3			12.0	33.3		24.0				
Change Period (Y+Rc), s		4.5			4.5	4.5		4.5				
Max Green Setting (Gmax), s		40.8			7.5	28.8		29.2				
Max Q Clear Time (g_c+I1), s		10.9			9.5	22.8		14.4				
Green Ext Time (p_c), s		2.9			0.0	3.6		5.0				

**Intersection Summary**

HCM 6th Ctrl Delay	31.8
HCM 6th LOS	C

**Notes**

User approved volume balancing among the lanes for turning movement.  
 Unsignalized Delay for [SBR] is excluded from calculations of the approach delay and intersection delay.

HCM 6th Signalized Intersection Summary      General Plan 2040 Project Altern. C Conditions  
 12: US 101 SB On Ramp/US 101 SB Off Ramp & Old Redwood Highway      Timing Plan: Saturday Midday Peak

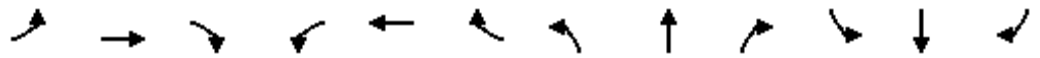

Movement	EBL	EBT	EBR	WBL	WBT	WBR	NBL	NBT	NBR	SBL	SBT	SBR
Lane Configurations		↑↑	↗	↖	↑↑					↖	↕	
Traffic Volume (veh/h)	0	713	543	632	1060	0	0	0	0	213	1	112
Future Volume (veh/h)	0	713	543	632	1060	0	0	0	0	213	1	112
Initial Q (Qb), veh	0	0	0	0	0	0				0	0	0
Ped-Bike Adj(A_pbT)	1.00		0.98	1.00		1.00				1.00		1.00
Parking Bus, Adj	1.00	1.00	1.00	1.00	1.00	1.00				1.00	1.00	1.00
Work Zone On Approach		No			No						No	
Adj Sat Flow, veh/h/ln	0	1870	1870	1870	1870	0				1870	1870	1870
Adj Flow Rate, veh/h	0	735	560	658	1104	0				226	98	0
Peak Hour Factor	0.97	0.97	0.97	0.96	0.96	0.96				0.72	0.72	0.72
Percent Heavy Veh, %	0	2	2	2	2	0				2	2	2
Cap, veh/h	0	1411	617	471	2579	0				260	273	
Arrive On Green	0.00	0.40	0.40	0.26	0.73	0.00				0.15	0.15	0.00
Sat Flow, veh/h	0	3647	1555	1781	3647	0				1781	1870	0
Grp Volume(v), veh/h	0	735	560	658	1104	0				226	98	0
Grp Sat Flow(s),veh/h/ln	0	1777	1555	1781	1777	0				1781	1870	0
Q Serve(g_s), s	0.0	11.0	23.8	18.5	8.7	0.0				8.7	3.3	0.0
Cycle Q Clear(g_c), s	0.0	11.0	23.8	18.5	8.7	0.0				8.7	3.3	0.0
Prop In Lane	0.00		1.00	1.00		0.00				1.00		0.00
Lane Grp Cap(c), veh/h	0	1411	617	471	2579	0				260	273	
V/C Ratio(X)	0.00	0.52	0.91	1.40	0.43	0.00				0.87	0.36	
Avail Cap(c_a), veh/h	0	1411	617	471	2579	0				260	273	
HCM Platoon Ratio	1.00	1.00	1.00	1.00	1.00	1.00				1.00	1.00	1.00
Upstream Filter(I)	0.00	1.00	1.00	1.00	1.00	0.00				1.00	1.00	0.00
Uniform Delay (d), s/veh	0.0	16.0	19.9	25.8	3.8	0.0				29.3	27.0	0.0
Incr Delay (d2), s/veh	0.0	1.4	19.4	191.5	0.5	0.0				25.8	0.8	0.0
Initial Q Delay(d3),s/veh	0.0	0.0	0.0	0.0	0.0	0.0				0.0	0.0	0.0
%ile BackOfQ(50%),veh/ln	0.0	4.3	10.9	32.2	2.0	0.0				5.4	1.5	0.0
Unsig. Movement Delay, s/veh												
LnGrp Delay(d),s/veh	0.0	17.4	39.3	217.3	4.3	0.0				55.1	27.8	0.0
LnGrp LOS	A	B	D	F	A	A				E	C	
Approach Vol, veh/h		1295			1762						324	
Approach Delay, s/veh		26.9			83.9						46.8	
Approach LOS		C			F						D	
Timer - Assigned Phs		2			5	6		8				
Phs Duration (G+Y+Rc), s		55.3			23.0	32.3		14.7				
Change Period (Y+Rc), s		4.5			4.5	4.5		4.5				
Max Green Setting (Gmax), s		50.8			18.5	27.8		10.2				
Max Q Clear Time (g_c+I1), s		10.7			20.5	25.8		10.7				
Green Ext Time (p_c), s		10.0			0.0	1.4		0.0				

**Intersection Summary**

HCM 6th Ctrl Delay	58.5
HCM 6th LOS	E

**Notes**

- User approved volume balancing among the lanes for turning movement.
- User approved ignoring U-Turning movement.
- Unsignalized Delay for [SBR] is excluded from calculations of the approach delay and intersection delay.

Queues  
1: Old Redwood Hwy & Shiloh Road

General Plan 2040 Project Altern. C Conditions

Timing Plan: A.M. PEAK



Lane Group	EBL	EBT	EBR	WBT	WBR	NBL	NBT	NBR	SBL	SBT	SBR
Lane Group Flow (vph)	386	242	511	225	21	372	332	19	45	559	468
v/c Ratio	0.84	0.50	0.67	0.73	0.06	1.68	0.45	0.03	0.50	0.99	0.83
Control Delay	59.1	41.7	9.5	60.4	0.3	358.0	30.3	0.1	74.5	77.7	40.2
Queue Delay	0.0	0.0	0.0	0.0	0.0	0.0	0.0	0.0	0.0	0.0	0.0
Total Delay	59.1	41.7	9.5	60.4	0.3	358.0	30.3	0.1	74.5	77.7	40.2
Queue Length 50th (ft)	274	154	18	162	0	~408	187	0	33	418	236
Queue Length 95th (ft)	#392	223	63	244	0	#641	302	0	#77	#649	#397
Internal Link Dist (ft)		1709		528			668			695	
Turn Bay Length (ft)	375		140		50	200		98	130		93
Base Capacity (vph)	466	490	770	605	590	221	733	669	91	563	567
Starvation Cap Reductn	0	0	0	0	0	0	0	0	0	0	0
Spillback Cap Reductn	0	0	0	0	0	0	0	0	0	0	0
Storage Cap Reductn	0	0	0	0	0	0	0	0	0	0	0
Reduced v/c Ratio	0.83	0.49	0.66	0.37	0.04	1.68	0.45	0.03	0.49	0.99	0.83

Intersection Summary

~ Volume exceeds capacity, queue is theoretically infinite.

Queue shown is maximum after two cycles.

# 95th percentile volume exceeds capacity, queue may be longer.

Queue shown is maximum after two cycles.

Queues

2: Shiloh Road & Hembree Ln

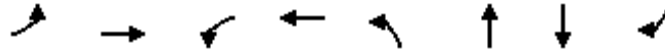

Lane Group	EBL	EBT	WBL	WBT	NBL	NBT	SBT	SBR
Lane Group Flow (vph)	353	987	49	882	49	27	155	606
v/c Ratio	0.46	0.88	0.38	0.63	0.38	0.20	0.66	0.90
Control Delay	32.0	26.0	49.0	20.4	49.0	28.6	52.4	37.5
Queue Delay	0.0	0.5	0.0	0.0	0.0	0.0	0.0	0.0
Total Delay	32.0	26.4	49.0	20.4	49.0	28.6	52.4	37.5
Queue Length 50th (ft)	94	455	27	178	27	6	87	~246
Queue Length 95th (ft)	134	#733	#65	235	#65	32	#189	#539
Internal Link Dist (ft)		222		1709		136	301	
Turn Bay Length (ft)			100					
Base Capacity (vph)	768	1283	128	1913	128	137	235	677
Starvation Cap Reductn	0	65	0	0	0	0	0	0
Spillback Cap Reductn	0	0	0	0	0	0	0	0
Storage Cap Reductn	0	0	0	0	0	0	0	0
Reduced v/c Ratio	0.46	0.81	0.38	0.46	0.38	0.20	0.66	0.90

Intersection Summary

~ Volume exceeds capacity, queue is theoretically infinite.

Queue shown is maximum after two cycles.

# 95th percentile volume exceeds capacity, queue may be longer.

Queue shown is maximum after two cycles.

Queues  
3: US 101 NB Off-Ramp & Shiloh Road

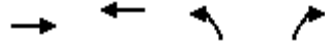

Lane Group	EBT	WBT	NBL	NBR
Lane Group Flow (vph)	743	1152	1070	680
v/c Ratio	0.46	1.35	1.40	0.51
Control Delay	14.5	187.7	212.4	11.2
Queue Delay	0.0	0.0	0.0	0.0
Total Delay	14.5	187.7	212.4	11.2
Queue Length 50th (ft)	113	~685	~651	76
Queue Length 95th (ft)	157	#912	#681	90
Internal Link Dist (ft)	106	291	689	
Turn Bay Length (ft)				265
Base Capacity (vph)	1622	853	762	1328
Starvation Cap Reductn	0	0	0	0
Spillback Cap Reductn	0	0	0	0
Storage Cap Reductn	0	0	0	0
Reduced v/c Ratio	0.46	1.35	1.40	0.51

Intersection Summary

- ~ Volume exceeds capacity, queue is theoretically infinite.  
Queue shown is maximum after two cycles.
- # 95th percentile volume exceeds capacity, queue may be longer.  
Queue shown is maximum after two cycles.

Queues  
4: Shiloh Road & US 101 SB Off-Ramp

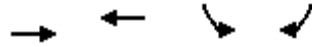

Lane Group	EBT	WBT	SBL	SBR
Lane Group Flow (vph)	444	1259	286	200
v/c Ratio	0.33	0.95	0.85	0.51
Control Delay	5.4	27.6	58.4	21.0
Queue Delay	0.0	0.0	0.0	0.0
Total Delay	5.4	27.6	58.4	21.0
Queue Length 50th (ft)	77	515	159	45
Queue Length 95th (ft)	116	#947	#297	113
Internal Link Dist (ft)	145	226	406	
Turn Bay Length (ft)				275
Base Capacity (vph)	1453	1453	363	410
Starvation Cap Reductn	0	0	0	0
Spillback Cap Reductn	0	0	0	0
Storage Cap Reductn	0	0	0	0
Reduced v/c Ratio	0.31	0.87	0.79	0.49

Intersection Summary

# 95th percentile volume exceeds capacity, queue may be longer.  
Queue shown is maximum after two cycles.

Queues  
6: Conde Lane & Shiloh Road

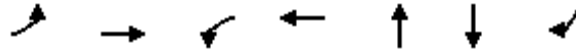

Lane Group	EBL	EBT	WBL	WBT	NBT	SBT	SBR
Lane Group Flow (vph)	58	557	9	1347	22	422	31
v/c Ratio	0.28	0.25	0.05	0.68	0.09	1.55	0.03
Control Delay	37.6	7.7	35.8	15.6	20.8	290.1	11.2
Queue Delay	0.0	0.0	0.0	0.0	0.0	0.0	0.0
Total Delay	37.6	7.7	35.8	15.6	20.8	290.1	11.2
Queue Length 50th (ft)	24	31	4	194	2	~271	6
Queue Length 95th (ft)	67	130	18	366	13	#505	22
Internal Link Dist (ft)		735		1001	338	442	
Turn Bay Length (ft)	90		127				40
Base Capacity (vph)	224	2293	198	1981	780	273	912
Starvation Cap Reductn	0	0	0	0	0	0	0
Spillback Cap Reductn	0	0	0	0	0	0	0
Storage Cap Reductn	0	0	0	0	0	0	0
Reduced v/c Ratio	0.26	0.24	0.05	0.68	0.03	1.55	0.03

Intersection Summary

- ~ Volume exceeds capacity, queue is theoretically infinite.  
Queue shown is maximum after two cycles.
- # 95th percentile volume exceeds capacity, queue may be longer.  
Queue shown is maximum after two cycles.



Queues

10: US 101 NB Off Ramp/Lakewood Drive & Old Redwood Highway



Lane Group	EBL	EBT	WBT	NBL	NBT	SBL	SBR
Lane Group Flow (vph)	311	728	978	212	422	287	763
v/c Ratio	0.79	0.76	0.80	0.61	0.57	0.93	0.99
Control Delay	50.6	23.1	29.7	35.0	27.0	75.7	47.0
Queue Delay	0.0	0.0	0.0	0.0	0.0	0.0	0.0
Total Delay	50.6	23.1	29.7	35.0	27.0	75.7	47.0
Queue Length 50th (ft)	77	265	215	102	89	73	265
Queue Length 95th (ft)	#145	452	301	173	134	#163	#510
Internal Link Dist (ft)		146	537		636		
Turn Bay Length (ft)	155			270		120	
Base Capacity (vph)	396	961	1218	599	1236	308	772
Starvation Cap Reductn	0	0	0	0	0	0	0
Spillback Cap Reductn	0	0	0	0	0	0	0
Storage Cap Reductn	0	0	0	0	0	0	0
Reduced v/c Ratio	0.79	0.76	0.80	0.35	0.34	0.93	0.99

Intersection Summary

# 95th percentile volume exceeds capacity, queue may be longer.  
 Queue shown is maximum after two cycles.

Queues

12: US 101 SB On Ramp/US 101 SB Off Ramp & Old Redwood Highway



Lane Group	EBT	EBR	WBL	WBT	SBL	SBT
Lane Group Flow (vph)	760	885	628	834	184	199
v/c Ratio	0.63	1.15	0.98	0.31	0.88	0.58
Control Delay	25.1	101.9	58.5	3.6	74.1	14.6
Queue Delay	0.0	0.0	0.0	0.0	0.0	0.0
Total Delay	25.1	101.9	58.5	3.6	74.1	14.6
Queue Length 50th (ft)	165	~400	304	55	96	10
Queue Length 95th (ft)	224	#624	#511	73	#184	55
Internal Link Dist (ft)	343			451		751
Turn Bay Length (ft)			250		420	
Base Capacity (vph)	1203	767	641	2663	210	346
Starvation Cap Reductn	0	0	0	0	0	0
Spillback Cap Reductn	0	0	0	0	0	0
Storage Cap Reductn	0	0	0	0	0	0
Reduced v/c Ratio	0.63	1.15	0.98	0.31	0.88	0.58

Intersection Summary

~ Volume exceeds capacity, queue is theoretically infinite.

Queue shown is maximum after two cycles.

# 95th percentile volume exceeds capacity, queue may be longer.

Queue shown is maximum after two cycles.

Queues  
1: Old Redwood Hwy & Shiloh Road

General Plan 2040 Project Altern. C Conditions

Timing Plan: P.M. Peak



Lane Group	EBL	EBT	EBR	WBT	WBR	NBL	NBT	NBR	SBL	SBT	SBR
Lane Group Flow (vph)	327	194	604	266	42	657	601	47	55	578	285
v/c Ratio	0.79	0.44	0.75	0.76	0.11	2.96	0.82	0.07	0.60	1.02	0.53
Control Delay	57.0	42.4	11.6	59.8	0.6	913.0	44.5	2.2	83.3	85.2	26.3
Queue Delay	0.0	0.0	0.0	0.0	0.0	0.0	0.0	0.0	0.0	0.0	0.0
Total Delay	57.0	42.4	11.6	59.8	0.6	913.0	44.5	2.2	83.3	85.2	26.3
Queue Length 50th (ft)	230	124	24	197	0	~879	430	0	42	~487	115
Queue Length 95th (ft)	#388	212	162	289	0	#1190	#716	11	#114	#780	223
Internal Link Dist (ft)		1709		528			668			695	
Turn Bay Length (ft)	375		140		50	200		98	130		93
Base Capacity (vph)	467	492	832	608	580	222	737	658	92	565	540
Starvation Cap Reductn	0	0	0	0	0	0	0	0	0	0	0
Spillback Cap Reductn	0	0	0	0	0	0	0	0	0	0	0
Storage Cap Reductn	0	0	0	0	0	0	0	0	0	0	0
Reduced v/c Ratio	0.70	0.39	0.73	0.44	0.07	2.96	0.82	0.07	0.60	1.02	0.53

Intersection Summary

~ Volume exceeds capacity, queue is theoretically infinite.

Queue shown is maximum after two cycles.

# 95th percentile volume exceeds capacity, queue may be longer.

Queue shown is maximum after two cycles.

## Queues

## General Plan 2040 Project Altern. C Conditions

## 2: Shiloh Road &amp; Hembree Ln

Timing Plan: P.M. Peak

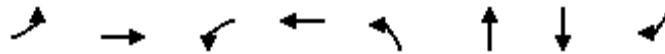

Lane Group	EBL	EBT	WBL	WBT	NBL	NBT	SBT	SBR
Lane Group Flow (vph)	703	1014	110	1108	111	149	194	554
v/c Ratio	1.05	0.95	0.99	0.71	1.00	0.67	0.96	1.03
Control Delay	85.4	37.0	127.9	22.2	130.3	27.3	94.4	72.6
Queue Delay	0.0	4.2	0.0	0.0	0.0	0.0	0.0	0.0
Total Delay	85.4	41.2	127.9	22.2	130.3	27.3	94.4	72.6
Queue Length 50th (ft)	~233	481	~65	246	~66	12	112	~252
Queue Length 95th (ft)	#342	#798	#171	303	#173	#91	#246	#529
Internal Link Dist (ft)		222		1709		136	301	
Turn Bay Length (ft)			100					
Base Capacity (vph)	669	1123	111	1663	111	222	203	537
Starvation Cap Reductn	0	66	0	0	0	0	0	0
Spillback Cap Reductn	0	0	0	0	0	0	0	0
Storage Cap Reductn	0	0	0	0	0	0	0	0
Reduced v/c Ratio	1.05	0.96	0.99	0.67	1.00	0.67	0.96	1.03

## Intersection Summary

~ Volume exceeds capacity, queue is theoretically infinite.

Queue shown is maximum after two cycles.

# 95th percentile volume exceeds capacity, queue may be longer.

Queue shown is maximum after two cycles.

Queues  
3: US 101 NB Off-Ramp & Shiloh Road

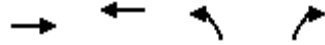

Lane Group	EBT	WBT	NBL	NBR
Lane Group Flow (vph)	843	947	771	870
v/c Ratio	0.52	1.11	1.01	0.67
Control Delay	15.3	87.9	58.8	16.1
Queue Delay	0.0	0.0	0.0	0.0
Total Delay	15.3	87.9	58.8	16.1
Queue Length 50th (ft)	133	~492	~339	135
Queue Length 95th (ft)	183	#707	#571	203
Internal Link Dist (ft)	106	291	689	
Turn Bay Length (ft)				265
Base Capacity (vph)	1622	853	762	1295
Starvation Cap Reductn	0	0	0	0
Spillback Cap Reductn	0	0	0	0
Storage Cap Reductn	0	0	0	0
Reduced v/c Ratio	0.52	1.11	1.01	0.67

Intersection Summary

- ~ Volume exceeds capacity, queue is theoretically infinite.  
Queue shown is maximum after two cycles.
- # 95th percentile volume exceeds capacity, queue may be longer.  
Queue shown is maximum after two cycles.

Queues  
4: Shiloh Road & US 101 SB Off-Ramp

General Plan 2040 Project Altern. C Conditions  
Timing Plan: P.M. Peak

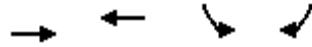

Lane Group	EBT	WBT	SBL	SBR
Lane Group Flow (vph)	721	1108	374	101
v/c Ratio	0.59	0.91	0.91	0.23
Control Delay	8.9	22.2	60.2	8.6
Queue Delay	0.0	0.0	0.0	0.0
Total Delay	8.9	22.2	60.2	8.6
Queue Length 50th (ft)	156	361	174	0
Queue Length 95th (ft)	225	581	#419	41
Internal Link Dist (ft)	145	226	406	
Turn Bay Length (ft)				275
Base Capacity (vph)	1601	1601	413	438
Starvation Cap Reductn	0	0	0	0
Spillback Cap Reductn	0	0	0	0
Storage Cap Reductn	0	0	0	0
Reduced v/c Ratio	0.45	0.69	0.91	0.23

Intersection Summary

# 95th percentile volume exceeds capacity, queue may be longer.  
Queue shown is maximum after two cycles.

Queues  
6: Conde Lane & Shiloh Road

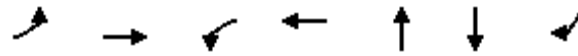

Lane Group	EBL	EBT	WBL	WBT	NBT	SBT	SBR
Lane Group Flow (vph)	88	803	11	1374	34	445	74
v/c Ratio	0.45	0.36	0.06	0.75	0.14	1.75	0.09
Control Delay	44.0	9.3	37.1	19.2	19.5	381.4	12.6
Queue Delay	0.0	0.0	0.0	0.0	0.0	0.0	0.0
Total Delay	44.0	9.3	37.1	19.2	19.5	381.4	12.6
Queue Length 50th (ft)	46	102	6	314	4	~384	22
Queue Length 95th (ft)	91	190	19	331	18	#549	44
Internal Link Dist (ft)		735		1001	338	442	
Turn Bay Length (ft)	90		127				40
Base Capacity (vph)	207	2236	184	1821	728	254	844
Starvation Cap Reductn	0	0	0	0	0	0	0
Spillback Cap Reductn	0	0	0	0	0	0	0
Storage Cap Reductn	0	0	0	0	0	0	0
Reduced v/c Ratio	0.43	0.36	0.06	0.75	0.05	1.75	0.09

Intersection Summary

- ~ Volume exceeds capacity, queue is theoretically infinite.  
Queue shown is maximum after two cycles.
- # 95th percentile volume exceeds capacity, queue may be longer.  
Queue shown is maximum after two cycles.

Queues

10: US 101 NB Off Ramp/Lakewood Drive & Old Redwood Highway



Lane Group	EBL	EBT	WBT	NBL	NBT	SBL	SBR
Lane Group Flow (vph)	355	784	1093	499	990	402	644
v/c Ratio	1.03	0.94	1.03	0.96	0.91	1.51	0.73
Control Delay	99.4	45.4	66.0	63.3	40.3	277.9	17.1
Queue Delay	0.0	0.0	0.0	0.0	0.0	0.0	0.0
Total Delay	99.4	45.4	66.0	63.3	40.3	277.9	17.1
Queue Length 50th (ft)	~112	412	~340	303	271	~165	174
Queue Length 95th (ft)	#189	#620	#468	#523	#402	#256	317
Internal Link Dist (ft)		146	537		636		
Turn Bay Length (ft)	155			270		120	
Base Capacity (vph)	343	832	1062	518	1087	267	880
Starvation Cap Reductn	0	0	0	0	0	0	0
Spillback Cap Reductn	0	0	0	0	0	0	0
Storage Cap Reductn	0	0	0	0	0	0	0
Reduced v/c Ratio	1.03	0.94	1.03	0.96	0.91	1.51	0.73

Intersection Summary

~ Volume exceeds capacity, queue is theoretically infinite.

Queue shown is maximum after two cycles.

# 95th percentile volume exceeds capacity, queue may be longer.

Queue shown is maximum after two cycles.



Queues

12: US 101 SB On Ramp/US 101 SB Off Ramp & Old Redwood Highway



Lane Group	EBT	EBR	WBL	WBT	SBL	SBT
Lane Group Flow (vph)	651	533	498	1260	337	306
v/c Ratio	0.46	0.60	1.09	0.50	1.36	0.99
Control Delay	16.8	6.4	98.8	5.3	216.5	74.1
Queue Delay	0.0	0.0	0.0	0.0	0.0	0.0
Total Delay	16.8	6.4	98.8	5.3	216.5	74.1
Queue Length 50th (ft)	105	24	~248	101	~206	96
Queue Length 95th (ft)	149	98	#412	133	#325	#222
Internal Link Dist (ft)	343			451		751
Turn Bay Length (ft)			250		420	
Base Capacity (vph)	1410	887	455	2522	247	308
Starvation Cap Reductn	0	0	0	0	0	0
Spillback Cap Reductn	0	0	0	0	0	0
Storage Cap Reductn	0	0	0	0	0	0
Reduced v/c Ratio	0.46	0.60	1.09	0.50	1.36	0.99

Intersection Summary

~ Volume exceeds capacity, queue is theoretically infinite.

Queue shown is maximum after two cycles.

# 95th percentile volume exceeds capacity, queue may be longer.

Queue shown is maximum after two cycles.

Queues  
1: Old Redwood Hwy & Shiloh Road

General Plan 2040 Project Altern. C Conditions  
Timing Plan: Saturday MIDDAY Peak



Lane Group	EBL	EBT	EBR	WBT	WBR	NBL	NBT	NBR	SBL	SBT	SBR
Lane Group Flow (vph)	204	235	270	294	43	267	368	38	48	302	292
v/c Ratio	0.58	0.63	0.52	0.71	0.10	0.98	0.56	0.06	0.45	0.71	0.61
Control Delay	44.0	45.4	9.4	46.5	0.4	95.4	32.5	0.2	65.1	45.3	21.4
Queue Delay	0.0	0.0	0.0	0.0	0.0	0.0	0.0	0.0	0.0	0.0	0.0
Total Delay	44.0	45.4	9.4	46.5	0.4	95.4	32.5	0.2	65.1	45.3	21.4
Queue Length 50th (ft)	109	128	4	160	0	~160	180	0	28	163	63
Queue Length 95th (ft)	227	259	77	302	0	#479	365	1	#105	324	185
Internal Link Dist (ft)		1709		528			668			695	
Turn Bay Length (ft)	375		140		50	200		98	130		93
Base Capacity (vph)	593	624	692	773	727	272	890	783	106	716	693
Starvation Cap Reductn	0	0	0	0	0	0	0	0	0	0	0
Spillback Cap Reductn	0	0	0	0	0	0	0	0	0	0	0
Storage Cap Reductn	0	0	0	0	0	0	0	0	0	0	0
Reduced v/c Ratio	0.34	0.38	0.39	0.38	0.06	0.98	0.41	0.05	0.45	0.42	0.42

Intersection Summary

~ Volume exceeds capacity, queue is theoretically infinite.

Queue shown is maximum after two cycles.

# 95th percentile volume exceeds capacity, queue may be longer.

Queue shown is maximum after two cycles.

Queues

General Plan 2040 Project Altern. C Conditions

2: Shiloh Road & Hembree Ln

Timing Plan: Saturday Midday Peak

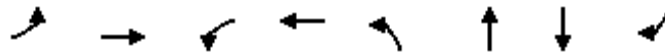

Lane Group	EBL	EBT	WBL	WBT	NBL	NBT	SBT	SBR
Lane Group Flow (vph)	977	601	110	705	111	149	270	941
v/c Ratio	1.14	0.71	0.77	0.66	0.78	0.60	1.03	1.19
Control Delay	105.0	19.6	70.1	19.5	71.1	21.6	100.0	113.2
Queue Delay	0.0	0.0	0.0	0.0	0.0	0.0	0.0	0.0
Total Delay	105.0	19.6	70.1	19.5	71.1	21.6	100.0	113.2
Queue Length 50th (ft)	~236	188	44	106	45	8	110	~340
Queue Length 95th (ft)	#504	283	#166	153	#168	#89	#345	#852
Internal Link Dist (ft)		222		1709		136	301	
Turn Bay Length (ft)			100					
Base Capacity (vph)	857	1428	142	2092	142	248	261	793
Starvation Cap Reductn	0	0	0	0	0	0	0	0
Spillback Cap Reductn	0	0	0	0	0	0	0	0
Storage Cap Reductn	0	0	0	0	0	0	0	0
Reduced v/c Ratio	1.14	0.42	0.77	0.34	0.78	0.60	1.03	1.19

Intersection Summary

~ Volume exceeds capacity, queue is theoretically infinite.

Queue shown is maximum after two cycles.

# 95th percentile volume exceeds capacity, queue may be longer.

Queue shown is maximum after two cycles.

Queues  
3: US 101 NB Off-Ramp & Shiloh Road

General Plan 2040 Project Altern. C Conditions  
Timing Plan: Saturday Midday Peak

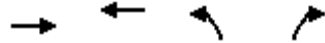

Lane Group	EBT	WBT	NBL	NBR
Lane Group Flow (vph)	631	1120	547	886
v/c Ratio	0.37	1.25	0.81	0.70
Control Delay	12.7	141.6	28.9	14.3
Queue Delay	0.0	0.0	0.0	0.0
Total Delay	12.7	141.6	28.9	14.3
Queue Length 50th (ft)	90	~643	195	108
Queue Length 95th (ft)	133	#872	312	175
Internal Link Dist (ft)	106	291	689	
Turn Bay Length (ft)				265
Base Capacity (vph)	1709	899	802	1431
Starvation Cap Reductn	0	0	0	0
Spillback Cap Reductn	0	0	0	0
Storage Cap Reductn	0	0	0	0
Reduced v/c Ratio	0.37	1.25	0.68	0.62

Intersection Summary

- ~ Volume exceeds capacity, queue is theoretically infinite.  
Queue shown is maximum after two cycles.
- # 95th percentile volume exceeds capacity, queue may be longer.  
Queue shown is maximum after two cycles.

Queues  
4: Shiloh Road & US 101 SB Off-Ramp

General Plan 2040 Project Altern. C Conditions  
Timing Plan: Saturday Midday Peak

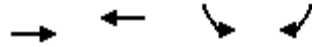

Lane Group	EBT	WBT	SBL	SBR
Lane Group Flow (vph)	416	802	428	328
v/c Ratio	0.42	0.82	0.79	0.50
Control Delay	8.8	17.9	34.9	8.7
Queue Delay	0.0	0.0	0.0	0.0
Total Delay	8.8	17.9	34.9	8.7
Queue Length 50th (ft)	73	191	124	17
Queue Length 95th (ft)	117	308	#227	41
Internal Link Dist (ft)	145	226	406	
Turn Bay Length (ft)				275
Base Capacity (vph)	1835	1835	539	659
Starvation Cap Reductn	0	0	0	0
Spillback Cap Reductn	0	0	0	0
Storage Cap Reductn	0	0	0	0
Reduced v/c Ratio	0.23	0.44	0.79	0.50

Intersection Summary

# 95th percentile volume exceeds capacity, queue may be longer.  
Queue shown is maximum after two cycles.

Queues  
6: Conde Lane & Shiloh Road

General Plan 2040 Project Altern. C Conditions  
Timing Plan: Saturday Midday Peak

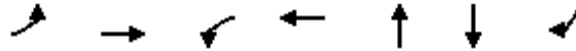

Lane Group	EBL	EBT	WBL	WBT	NBT	SBT	SBR
Lane Group Flow (vph)	45	552	14	979	18	373	53
v/c Ratio	0.16	0.31	0.05	0.66	0.04	0.98	0.08
Control Delay	32.3	9.8	32.7	15.8	0.2	76.2	13.2
Queue Delay	0.0	0.0	0.0	0.0	0.0	0.0	0.0
Total Delay	32.3	9.8	32.7	15.8	0.2	76.2	13.2
Queue Length 50th (ft)	13	33	4	118	0	~140	10
Queue Length 95th (ft)	55	136	25	253	0	#381	31
Internal Link Dist (ft)		735		1001	338	442	
Turn Bay Length (ft)	90		127				40
Base Capacity (vph)	294	2704	276	2530	1086	380	1190
Starvation Cap Reductn	0	0	0	0	0	0	0
Spillback Cap Reductn	0	0	0	0	0	0	0
Storage Cap Reductn	0	0	0	0	0	0	0
Reduced v/c Ratio	0.15	0.20	0.05	0.39	0.02	0.98	0.04

Intersection Summary

~ Volume exceeds capacity, queue is theoretically infinite.

Queue shown is maximum after two cycles.

# 95th percentile volume exceeds capacity, queue may be longer.

Queue shown is maximum after two cycles.

Queues

General Plan 2040 Project Altern. C Conditions

10: US 101 NB Off Ramp/Lakewood Drive & Old Redwood Highway Timing Plan: Saturday Midday Peak



Lane Group	EBL	EBT	WBT	NBL	NBT	SBL	SBR
Lane Group Flow (vph)	392	445	1154	338	675	359	1032
v/c Ratio	1.31	0.50	0.97	0.73	0.70	1.29	1.26
Control Delay	195.7	19.0	46.5	37.9	28.9	188.2	149.0
Queue Delay	0.0	0.0	0.0	0.0	0.0	0.0	0.0
Total Delay	195.7	19.0	46.5	37.9	28.9	188.2	149.0
Queue Length 50th (ft)	~150	170	310	180	162	~135	~639
Queue Length 95th (ft)	#244	267	#464	285	224	#220	#853
Internal Link Dist (ft)		146	537		636		
Turn Bay Length (ft)	155			270		120	
Base Capacity (vph)	299	884	1194	547	1134	279	817
Starvation Cap Reductn	0	0	0	0	0	0	0
Spillback Cap Reductn	0	0	0	0	0	0	0
Storage Cap Reductn	0	0	0	0	0	0	0
Reduced v/c Ratio	1.31	0.50	0.97	0.62	0.60	1.29	1.26

Intersection Summary

~ Volume exceeds capacity, queue is theoretically infinite.

Queue shown is maximum after two cycles.

# 95th percentile volume exceeds capacity, queue may be longer.

Queue shown is maximum after two cycles.

Queues

General Plan 2040 Project Altern. C Conditions

12: US 101 SB On Ramp/US 101 SB Off Ramp & Old Redwood Highway Timing Plan: Saturday Midday Peak



Lane Group	EBT	EBR	WBL	WBT	SBL	SBT
Lane Group Flow (vph)	735	560	658	1104	237	216
v/c Ratio	0.52	0.65	1.41	0.43	0.97	0.62
Control Delay	17.7	8.7	222.1	4.4	84.8	19.8
Queue Delay	0.0	0.0	0.0	0.0	0.0	0.0
Total Delay	17.7	8.7	222.1	4.4	84.8	19.8
Queue Length 50th (ft)	123	42	~389	77	108	30
Queue Length 95th (ft)	171	136	#579	105	#173	60
Internal Link Dist (ft)	343			451		751
Turn Bay Length (ft)			250		420	
Base Capacity (vph)	1405	863	467	2568	244	347
Starvation Cap Reductn	0	0	0	0	0	0
Spillback Cap Reductn	0	0	0	0	0	0
Storage Cap Reductn	0	0	0	0	0	0
Reduced v/c Ratio	0.52	0.65	1.41	0.43	0.97	0.62

Intersection Summary

~ Volume exceeds capacity, queue is theoretically infinite.

Queue shown is maximum after two cycles.

























# 95th percentile volume exceeds capacity, queue may be longer.

Queue shown is maximum after two cycles.



HCM 6th Signalized Intersection Summary  
 1: Old Redwood Hwy & Shiloh Road

GP 2040+Project Alternative C\_Mitigations  
 Timing Plan: A.M. PEAK

												
Movement	EBL	EBT	EBR	WBL	WBT	WBR	NBL	NBT	NBR	SBL	SBT	SBR
Lane Configurations												
Traffic Volume (veh/h)	313	196	414	40	160	19	346	309	18	38	475	398
Future Volume (veh/h)	313	196	414	40	160	19	346	309	18	38	475	398
Initial Q (Qb), veh	0	0	0	0	0	0	0	0	0	0	0	0
Ped-Bike Adj(A_pbT)	1.00		1.00	1.00		1.00	1.00		1.00	1.00		0.99
Parking Bus, Adj	1.00	1.00	1.00	1.00	1.00	1.00	1.00	1.00	1.00	1.00	1.00	1.00
Work Zone On Approach		No			No			No			No	
Adj Sat Flow, veh/h/ln	1870	1870	1870	1870	1870	1870	1870	1870	1870	1870	1870	1870
Adj Flow Rate, veh/h	313	196	414	40	160	19	346	309	18	38	475	398
Peak Hour Factor	1.00	1.00	1.00	1.00	1.00	1.00	1.00	1.00	1.00	1.00	1.00	1.00
Percent Heavy Veh, %	2	2	2	2	2	2	2	2	2	2	2	2
Cap, veh/h	352	509	631	116	261	221	435	693	587	116	579	484
Arrive On Green	0.20	0.27	0.27	0.06	0.14	0.14	0.13	0.37	0.37	0.06	0.31	0.31
Sat Flow, veh/h	1781	1870	1585	1781	1870	1585	3456	1870	1585	1781	1870	1565
Grp Volume(v), veh/h	313	196	414	40	160	19	346	309	18	38	475	398
Grp Sat Flow(s),veh/h/ln	1781	1870	1585	1781	1870	1585	1728	1870	1585	1781	1870	1565
Q Serve(g_s), s	13.2	6.6	16.4	1.7	6.2	0.8	7.5	9.6	0.6	1.6	18.1	18.1
Cycle Q Clear(g_c), s	13.2	6.6	16.4	1.7	6.2	0.8	7.5	9.6	0.6	1.6	18.1	18.1
Prop In Lane	1.00		1.00	1.00		1.00	1.00		1.00	1.00		1.00
Lane Grp Cap(c), veh/h	352	509	631	116	261	221	435	693	587	116	579	484
V/C Ratio(X)	0.89	0.38	0.66	0.35	0.61	0.09	0.80	0.45	0.03	0.33	0.82	0.82
Avail Cap(c_a), veh/h	359	1110	1141	157	899	762	494	972	824	116	826	691
HCM Platoon Ratio	1.00	1.00	1.00	1.00	1.00	1.00	1.00	1.00	1.00	1.00	1.00	1.00
Upstream Filter(I)	1.00	1.00	1.00	1.00	1.00	1.00	1.00	1.00	1.00	1.00	1.00	1.00
Uniform Delay (d), s/veh	30.1	22.8	18.9	34.4	31.1	28.8	32.7	18.3	15.4	34.4	24.6	24.6
Incr Delay (d2), s/veh	22.7	0.5	1.2	1.8	2.3	0.2	7.9	0.5	0.0	1.6	4.5	5.4
Initial Q Delay(d3),s/veh	0.0	0.0	0.0	0.0	0.0	0.0	0.0	0.0	0.0	0.0	0.0	0.0
%ile BackOfQ(50%),veh/ln	7.5	2.7	5.4	0.7	2.8	0.3	3.4	3.7	0.2	0.7	8.0	6.7
Unsig. Movement Delay, s/veh												
LnGrp Delay(d),s/veh	52.7	23.2	20.0	36.2	33.5	29.0	40.6	18.7	15.4	36.0	29.1	30.0
LnGrp LOS	D	C	C	D	C	C	D	B	B	D	C	C
Approach Vol, veh/h		923			219			673			911	
Approach Delay, s/veh		31.8			33.6			29.9			29.8	
Approach LOS		C			C			C			C	
Timer - Assigned Phs	1	2	3	4	5	6	7	8				
Phs Duration (G+Y+Rc), s	9.5	25.5	13.7	28.3	19.7	15.3	9.0	33.0				
Change Period (Y+Rc), s	4.5	4.5	4.0	4.5	4.5	4.5	4.0	4.5				
Max Green Setting (Gmax), s	6.8	45.7	11.0	34.0	15.5	37.0	5.0	40.0				
Max Q Clear Time (g_c+I1), s	3.7	18.4	9.5	20.1	15.2	8.2	3.6	11.6				
Green Ext Time (p_c), s	0.0	2.6	0.2	3.7	0.0	0.9	0.0	1.7				
<b>Intersection Summary</b>												
HCM 6th Ctrl Delay			30.8									
HCM 6th LOS			C									

HCM 6th Signalized Intersection Summary  
2: Shiloh Road & Hembree Ln

GP 2040+Project Alternative C\_Mitigations  
Timing Plan: A.M. PEAK



Movement	EBL	EBT	EBR	WBL	WBT	WBR	NBL	NBT	NBR	SBL	SBT	SBR
Lane Configurations	↖↗	↑↘		↖↑	↑↘		↖	↘		↖	↑	↗↘
Traffic Volume (veh/h)	311	778	103	49	765	90	49	11	16	129	18	570
Future Volume (veh/h)	311	778	103	49	765	90	49	11	16	129	18	570
Initial Q (Qb), veh	0	0	0	0	0	0	0	0	0	0	0	0
Ped-Bike Adj(A_pbT)	1.00		1.00	1.00		1.00	1.00		1.00	1.00		1.00
Parking Bus, Adj	1.00	1.00	1.00	1.00	1.00	1.00	1.00	1.00	1.00	1.00	1.00	1.00
Work Zone On Approach		No			No			No			No	
Adj Sat Flow, veh/h/ln	1870	1870	1870	1870	1870	1870	1870	1870	1870	1870	1870	1870
Adj Flow Rate, veh/h	353	884	103	49	789	93	49	11	16	137	18	606
Peak Hour Factor	0.88	0.88	1.00	1.00	0.97	0.97	1.00	1.00	1.00	0.94	1.00	0.94
Percent Heavy Veh, %	2	2	2	2	2	2	2	2	2	2	2	2
Cap, veh/h	484	1426	166	85	1130	133	156	71	104	199	239	747
Arrive On Green	0.14	0.44	0.44	0.05	0.35	0.35	0.09	0.10	0.10	0.11	0.13	0.13
Sat Flow, veh/h	3456	3206	374	1781	3202	377	1781	689	1002	1781	1870	2790
Grp Volume(v), veh/h	353	490	497	49	438	444	49	0	27	137	18	606
Grp Sat Flow(s),veh/h/ln	1728	1777	1803	1781	1777	1802	1781	0	1690	1781	1870	1395
Q Serve(g_s), s	5.4	11.6	11.6	1.5	11.6	11.6	1.4	0.0	0.8	4.1	0.5	7.0
Cycle Q Clear(g_c), s	5.4	11.6	11.6	1.5	11.6	11.6	1.4	0.0	0.8	4.1	0.5	7.0
Prop In Lane	1.00		0.21	1.00		0.21	1.00		0.59	1.00		1.00
Lane Grp Cap(c), veh/h	484	790	802	85	627	636	156	0	175	199	239	747
V/C Ratio(X)	0.73	0.62	0.62	0.57	0.70	0.70	0.31	0.00	0.15	0.69	0.08	0.81
Avail Cap(c_a), veh/h	631	1426	1448	211	1313	1332	211	0	175	260	239	747
HCM Platoon Ratio	1.00	1.00	1.00	1.00	1.00	1.00	1.00	1.00	1.00	1.00	1.00	1.00
Upstream Filter(I)	1.00	1.00	1.00	1.00	1.00	1.00	1.00	0.00	1.00	1.00	1.00	1.00
Uniform Delay (d), s/veh	22.6	11.7	11.7	25.5	15.2	15.2	23.5	0.0	22.4	23.4	21.1	18.8
Incr Delay (d2), s/veh	3.0	0.8	0.8	5.9	1.4	1.4	1.1	0.0	0.4	5.0	0.1	6.8
Initial Q Delay(d3),s/veh	0.0	0.0	0.0	0.0	0.0	0.0	0.0	0.0	0.0	0.0	0.0	0.0
%ile BackOfQ(50%),veh/ln	2.1	3.6	3.7	0.7	4.0	4.1	0.6	0.0	0.3	1.8	0.2	3.9
Unsig. Movement Delay, s/veh												
LnGrp Delay(d),s/veh	25.6	12.5	12.5	31.5	16.7	16.6	24.6	0.0	22.8	28.4	21.2	25.6
LnGrp LOS	C	B	B	C	B	B	C	A	C	C	C	C
Approach Vol, veh/h		1340			931			76			761	
Approach Delay, s/veh		15.9			17.4			23.9			26.0	
Approach LOS		B			B			C			C	
Timer - Assigned Phs	1	2	3	4	5	6	7	8				
Phs Duration (G+Y+Rc), s	6.6	28.4	8.8	11.0	11.7	23.3	10.1	9.7				
Change Period (Y+Rc), s	4.0	4.0	4.0	4.0	4.0	4.0	4.0	4.0				
Max Green Setting (Gmax), s	6.5	44.0	6.5	7.0	10.0	40.5	8.0	5.5				
Max Q Clear Time (g_c+1), s	13.5	13.6	3.4	9.0	7.4	13.6	6.1	2.8				
Green Ext Time (p_c), s	0.0	6.8	0.0	0.0	0.3	5.7	0.1	0.0				

Intersection Summary

HCM 6th Ctrl Delay	19.0
HCM 6th LOS	B

HCM 6th Signalized Intersection Summary  
 3: US 101 NB Off-Ramp & Shiloh Road

GP 2040+Project Alternative C\_Mitigations  
 Timing Plan: A.M. PEAK

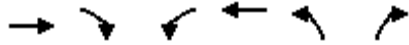

Movement	EBT	EBR	WBL	WBT	NBL	NBR
Lane Configurations	↑↑			↑↑	↘	↗↗
Traffic Volume (veh/h)	676	0	0	1037	813	517
Future Volume (veh/h)	676	0	0	1037	813	517
Initial Q (Qb), veh	0	0	0	0	0	0
Ped-Bike Adj(A_pbT)		1.00	1.00		1.00	1.00
Parking Bus, Adj	1.00	1.00	1.00	1.00	1.00	1.00
Work Zone On Approach	No			No	No	
Adj Sat Flow, veh/h/ln	1870	0	0	1870	1870	1870
Adj Flow Rate, veh/h	743	0	0	1152	1070	680
Peak Hour Factor	0.91	0.91	0.90	0.90	0.76	0.76
Percent Heavy Veh, %	2	0	0	2	2	2
Cap, veh/h	1155	0	0	1155	1024	1604
Arrive On Green	0.32	0.00	0.00	0.32	0.57	0.57
Sat Flow, veh/h	3741	0	0	3741	1781	2790
Grp Volume(v), veh/h	743	0	0	1152	1070	680
Grp Sat Flow(s),veh/h/ln	1777	0	0	1777	1781	1395
Q Serve(g_s), s	14.3	0.0	0.0	25.9	46.0	11.0
Cycle Q Clear(g_c), s	14.3	0.0	0.0	25.9	46.0	11.0
Prop In Lane		0.00	0.00		1.00	1.00
Lane Grp Cap(c), veh/h	1155	0	0	1155	1024	1604
V/C Ratio(X)	0.64	0.00	0.00	1.00	1.04	0.42
Avail Cap(c_a), veh/h	1155	0	0	1155	1024	1604
HCM Platoon Ratio	1.00	1.00	1.00	1.00	1.00	1.00
Upstream Filter(I)	1.00	0.00	0.00	1.00	1.00	1.00
Uniform Delay (d), s/veh	23.0	0.0	0.0	27.0	17.0	9.6
Incr Delay (d2), s/veh	1.2	0.0	0.0	25.8	40.5	0.2
Initial Q Delay(d3),s/veh	0.0	0.0	0.0	0.0	0.0	0.0
%ile BackOfQ(50%),veh/ln	5.7	0.0	0.0	14.1	27.3	3.0
Unsig. Movement Delay, s/veh						
LnGrp Delay(d),s/veh	24.3	0.0	0.0	52.8	57.5	9.7
LnGrp LOS	C	A	A	D	F	A
Approach Vol, veh/h	743			1152	1750	
Approach Delay, s/veh	24.3			52.8	38.9	
Approach LOS	C			D	D	
Timer - Assigned Phs		2			6	8
Phs Duration (G+Y+Rc), s		30.0			30.0	50.0
Change Period (Y+Rc), s		4.0			4.0	4.0
Max Green Setting (Gmax), s		26.0			26.0	46.0
Max Q Clear Time (g_c+I1), s		16.3			27.9	48.0
Green Ext Time (p_c), s		3.3			0.0	0.0
<b>Intersection Summary</b>						
HCM 6th Ctrl Delay			40.3			
HCM 6th LOS			D			

Intersection						
Int Delay, s/veh	2.4					
Movement	EBT	EBR	WBL	WBT	NBL	NBR
Lane Configurations	↑↑		↘	↑↑	↘	↘
Traffic Vol, veh/h	891	14	130	1200	17	122
Future Vol, veh/h	891	14	130	1200	17	122
Conflicting Peds, #/hr	0	0	0	0	0	0
Sign Control	Free	Free	Free	Free	Stop	Stop
RT Channelized	-	None	-	None	-	None
Storage Length	-	-	68	-	0	0
Veh in Median Storage, #	0	-	-	0	0	-
Grade, %	0	-	-	0	0	-
Peak Hour Factor	96	96	87	87	84	84
Heavy Vehicles, %	2	2	2	2	2	2
Mvmt Flow	928	15	149	1379	20	145

Major/Minor	Major1	Major2	Minor1		
Conflicting Flow All	0	0	943	0	1924 472
Stage 1	-	-	-	-	936 -
Stage 2	-	-	-	-	988 -
Critical Hdwy	-	-	4.14	-	6.84 6.94
Critical Hdwy Stg 1	-	-	-	-	5.84 -
Critical Hdwy Stg 2	-	-	-	-	5.84 -
Follow-up Hdwy	-	-	2.22	-	3.52 3.32
Pot Cap-1 Maneuver	-	-	723	-	59 538
Stage 1	-	-	-	-	342 -
Stage 2	-	-	-	-	321 -
Platoon blocked, %	-	-	-	-	-
Mov Cap-1 Maneuver	-	-	723	-	47 538
Mov Cap-2 Maneuver	-	-	-	-	47 -
Stage 1	-	-	-	-	342 -
Stage 2	-	-	-	-	255 -

Approach	EB	WB	NB
HCM Control Delay, s	0	1.1	28.3
HCM LOS			D

Minor Lane/Major Mvmt	NBLn1	NBLn2	EBT	EBR	WBL	WBT
Capacity (veh/h)	47	538	-	-	723	-
HCM Lane V/C Ratio	0.431	0.27	-	-	0.207	-
HCM Control Delay (s)	130.3	14.1	-	-	11.3	-
HCM Lane LOS	F	B	-	-	B	-
HCM 95th %tile Q(veh)	1.6	1.1	-	-	0.8	-

HCM Signalized Intersection Capacity Analysis  
6: Conde Lane & Shiloh Road

GP 2040+Project Alternative C\_Mitigations  
Timing Plan: A.M. PEAK



Movement	EBL	EBT	EBR	WBL	WBT	WBR	NBL	NBT	NBR	SBL	SBT	SBR
Lane Configurations												
Traffic Volume (vph)	55	526	3	8	847	298	2	1	9	363	0	27
Future Volume (vph)	55	526	3	8	847	298	2	1	9	363	0	27
Ideal Flow (vphpl)	1900	1900	1900	1900	1900	1900	1900	1900	1900	1900	1900	1900
Total Lost time (s)	4.0	4.0		4.0	4.0			4.0			4.0	4.0
Lane Util. Factor	1.00	0.95		1.00	0.95			1.00			1.00	1.00
Frt	1.00	1.00		1.00	0.96			0.90			1.00	0.85
Flt Protected	0.95	1.00		0.95	1.00			0.99			0.95	1.00
Satd. Flow (prot)	1770	3536		1770	3401			1660			1770	1583
Flt Permitted	0.95	1.00		0.95	1.00			0.99			0.95	1.00
Satd. Flow (perm)	1770	3536		1770	3401			1660			1770	1583
Peak-hour factor, PHF	1.00	1.00	1.00	1.00	1.00	1.00	1.00	1.00	1.00	1.00	1.00	1.00
Adj. Flow (vph)	55	526	3	8	847	298	2	1	9	363	0	27
RTOR Reduction (vph)	0	0	0	0	25	0	0	9	0	0	0	0
Lane Group Flow (vph)	55	529	0	8	1120	0	0	3	0	0	363	27
Turn Type	Prot	NA		Prot	NA		Split	NA		Split	NA	custom
Protected Phases	5	2		1	6		7	7		4	4	
Permitted Phases												6
Actuated Green, G (s)	6.0	40.8		1.2	36.0			1.5			21.9	36.0
Effective Green, g (s)	6.0	40.8		1.2	36.0			1.5			21.9	36.0
Actuated g/C Ratio	0.07	0.50		0.01	0.44			0.02			0.27	0.44
Clearance Time (s)	4.0	4.0		4.0	4.0			4.0			4.0	4.0
Vehicle Extension (s)	3.0	3.0		3.0	3.0			3.0			3.0	3.0
Lane Grp Cap (vph)	130	1772		26	1504			30			476	700
v/s Ratio Prot	c0.03	0.15		0.00	c0.33			c0.00			c0.21	
v/s Ratio Perm												0.02
v/c Ratio	0.42	0.30		0.31	0.74			0.11			0.76	0.04
Uniform Delay, d1	36.0	11.9		39.7	18.9			39.3			27.4	12.9
Progression Factor	1.00	1.00		1.00	1.00			1.00			1.00	1.00
Incremental Delay, d2	2.2	0.1		6.6	2.0			1.6			7.1	0.0
Delay (s)	38.3	12.0		46.3	20.9			40.8			34.5	12.9
Level of Service	D	B		D	C			D			C	B
Approach Delay (s)		14.5			21.1			40.8			33.0	
Approach LOS		B			C			D			C	

Intersection Summary		
HCM 2000 Control Delay	21.6	HCM 2000 Level of Service C
HCM 2000 Volume to Capacity ratio	0.71	
Actuated Cycle Length (s)	81.4	Sum of lost time (s) 16.0
Intersection Capacity Utilization	76.4%	ICU Level of Service D
Analysis Period (min)	15	

c Critical Lane Group

HCM 6th Signalized Intersection Summary  
8: Old Redwood Hwy & Entrance 1

GP 2040+Project Alternative C\_Mitigations  
Timing Plan: A.M. PEAK



Movement	EBL	EBT	EBR	WBL	WBT	WBR	NBL	NBT	NBR	SBL	SBT	SBR
Lane Configurations		↕		↖	↗			↕		↖	↗	
Traffic Volume (veh/h)	1	0	0	6	0	10	0	662	9	15	914	0
Future Volume (veh/h)	1	0	0	6	0	10	0	662	9	15	914	0
Initial Q (Qb), veh	0	0	0	0	0	0	0	0	0	0	0	0
Ped-Bike Adj(A_pbT)	1.00		1.00	1.00		1.00	1.00		0.99	1.00		1.00
Parking Bus, Adj	1.00	1.00	1.00	1.00	1.00	1.00	1.00	1.00	1.00	1.00	1.00	1.00
Work Zone On Approach		No			No			No			No	
Adj Sat Flow, veh/h/ln	1870	1870	1870	1870	1870	1870	1870	1870	1870	1870	1870	1870
Adj Flow Rate, veh/h	4	0	0	6	0	10	0	669	9	17	1016	0
Peak Hour Factor	0.25	0.25	0.25	1.00	1.00	1.00	0.99	0.99	0.99	0.90	0.90	0.90
Percent Heavy Veh, %	2	2	2	2	2	2	2	2	2	2	2	2
Cap, veh/h	251	0	0	263	0	79	0	1242	17	561	1262	0
Arrive On Green	0.05	0.00	0.00	0.05	0.00	0.05	0.00	0.67	0.67	0.67	0.67	0.00
Sat Flow, veh/h	1236	0	0	1418	0	1585	0	1841	25	761	1870	0
Grp Volume(v), veh/h	4	0	0	6	0	10	0	0	678	17	1016	0
Grp Sat Flow(s),veh/h/ln	1236	0	0	1418	0	1585	0	0	1866	761	1870	0
Q Serve(g_s), s	0.1	0.0	0.0	0.0	0.0	0.2	0.0	0.0	7.1	0.4	14.8	0.0
Cycle Q Clear(g_c), s	0.3	0.0	0.0	0.1	0.0	0.2	0.0	0.0	7.1	7.5	14.8	0.0
Prop In Lane	1.00		0.00	1.00		1.00	0.00		0.01	1.00		0.00
Lane Grp Cap(c), veh/h	251	0	0	263	0	79	0	0	1258	561	1262	0
V/C Ratio(X)	0.02	0.00	0.00	0.02	0.00	0.13	0.00	0.00	0.54	0.03	0.81	0.00
Avail Cap(c_a), veh/h	884	0	0	902	0	794	0	0	2221	954	2227	0
HCM Platoon Ratio	1.00	1.00	1.00	1.00	1.00	1.00	1.00	1.00	1.00	1.00	1.00	1.00
Upstream Filter(I)	1.00	0.00	0.00	1.00	0.00	1.00	0.00	0.00	1.00	1.00	1.00	0.00
Uniform Delay (d), s/veh	17.5	0.0	0.0	17.3	0.0	17.3	0.0	0.0	3.2	5.1	4.4	0.0
Incr Delay (d2), s/veh	0.0	0.0	0.0	0.0	0.0	0.7	0.0	0.0	0.4	0.0	1.3	0.0
Initial Q Delay(d3),s/veh	0.0	0.0	0.0	0.0	0.0	0.0	0.0	0.0	0.0	0.0	0.0	0.0
%ile BackOfQ(50%),veh/ln	0.0	0.0	0.0	0.0	0.0	0.1	0.0	0.0	0.1	0.0	0.4	0.0
Unsig. Movement Delay, s/veh												
LnGrp Delay(d),s/veh	17.5	0.0	0.0	17.3	0.0	18.0	0.0	0.0	3.5	5.1	5.7	0.0
LnGrp LOS	B	A	A	B	A	B	A	A	A	A	A	A
Approach Vol, veh/h		4			16			678			1033	
Approach Delay, s/veh		17.5			17.7			3.5			5.7	
Approach LOS		B			B			A			A	
Timer - Assigned Phs		2		4		6		8				
Phs Duration (G+Y+Rc), s		31.5		6.6		31.5		6.6				
Change Period (Y+Rc), s		5.8		* 4.7		5.8		* 4.7				
Max Green Setting (Gmax), s		45.4		* 19		45.4		* 19				
Max Q Clear Time (g_c+I1), s		9.1		2.3		16.8		2.2				
Green Ext Time (p_c), s		4.7		0.0		9.0		0.0				

Intersection Summary

HCM 6th Ctrl Delay	5.0
HCM 6th LOS	A

Notes

\* HCM 6th computational engine requires equal clearance times for the phases crossing the barrier.

HCM 6th Signalized Intersection Summary

GP 2040+Project Alternative C\_Mitigations

12: US 101 SB On Ramp/US 101 SB Off Ramp & Old Redwood Highway

Timing Plan: A.M. PEAK



Movement	EBL	EBT	EBR	WBL	WBT	WBR	NBL	NBT	NBR	SBL	SBT	SBR
Lane Configurations		↑↑	↑	↑	↑↑					↑	↔	
Traffic Volume (veh/h)	0	699	814	559	742	0	0	0	0	166	0	144
Future Volume (veh/h)	0	699	814	559	742	0	0	0	0	166	0	144
Initial Q (Qb), veh	0	0	0	0	0	0				0	0	0
Ped-Bike Adj(A_pbT)	1.00		0.99	1.00		1.00				1.00		1.00
Parking Bus, Adj	1.00	1.00	1.00	1.00	1.00	1.00				1.00	1.00	1.00
Work Zone On Approach		No			No						No	
Adj Sat Flow, veh/h/ln	0	1870	1870	1870	1870	0				1870	1870	1870
Adj Flow Rate, veh/h	0	699	814	559	742	0				155	15	0
Peak Hour Factor	1.00	1.00	1.00	1.00	1.00	1.00				1.00	1.00	1.00
Percent Heavy Veh, %	0	2	2	2	2	0				2	2	2
Cap, veh/h	0	1588	698	600	2914	0				162	170	
Arrive On Green	0.00	0.45	0.45	0.34	0.82	0.00				0.09	0.09	0.00
Sat Flow, veh/h	0	3647	1561	1781	3647	0				1781	1870	0
Grp Volume(v), veh/h	0	699	814	559	742	0				155	15	0
Grp Sat Flow(s),veh/h/ln	0	1777	1561	1781	1777	0				1781	1870	0
Q Serve(g_s), s	0.0	14.9	49.2	33.4	5.2	0.0				9.5	0.8	0.0
Cycle Q Clear(g_c), s	0.0	14.9	49.2	33.4	5.2	0.0				9.5	0.8	0.0
Prop In Lane	0.00		1.00	1.00		0.00				1.00		0.00
Lane Grp Cap(c), veh/h	0	1588	698	600	2914	0				162	170	
V/C Ratio(X)	0.00	0.44	1.17	0.93	0.25	0.00				0.96	0.09	
Avail Cap(c_a), veh/h	0	1588	698	823	2914	0				162	170	
HCM Platoon Ratio	1.00	1.00	1.00	1.00	1.00	1.00				1.00	1.00	1.00
Upstream Filter(I)	0.00	1.00	1.00	1.00	1.00	0.00				1.00	1.00	0.00
Uniform Delay (d), s/veh	0.0	20.9	30.4	35.3	2.3	0.0				49.8	45.8	0.0
Incr Delay (d2), s/veh	0.0	0.9	90.1	14.0	0.2	0.0				57.9	0.2	0.0
Initial Q Delay(d3),s/veh	0.0	0.0	0.0	0.0	0.0	0.0				0.0	0.0	0.0
%ile BackOfQ(50%),veh/ln	0.0	6.2	34.9	16.3	1.2	0.0				6.8	0.4	0.0
Unsig. Movement Delay, s/veh												
LnGrp Delay(d),s/veh	0.0	21.8	120.5	49.3	2.5	0.0				107.7	46.0	0.0
LnGrp LOS		A	C	F	D	A				F	D	
Approach Vol, veh/h		1513			1301					170		
Approach Delay, s/veh		74.9			22.6					102.2		
Approach LOS		E			C					F		
Timer - Assigned Phs		2			5	6		8				
Phs Duration (G+Y+Rc), s		95.3			41.0	54.3		14.7				
Change Period (Y+Rc), s		5.1			4.0	5.1		4.7				
Max Green Setting (Gmax), s		90.2			50.8	35.4		10.0				
Max Q Clear Time (g_c+11), s		7.2			35.4	51.2		11.5				
Green Ext Time (p_c), s		6.0			1.7	0.0		0.0				

Intersection Summary

























HCM 6th Ctrl Delay	53.6
HCM 6th LOS	D

Notes

- User approved volume balancing among the lanes for turning movement.
- User approved ignoring U-Turning movement.
- Unsignalized Delay for [SBR] is excluded from calculations of the approach delay and intersection delay.

HCM 6th Signalized Intersection Summary  
 1: Old Redwood Hwy & Shiloh Road

GP 2040+Project Alternative C\_Mitigations  
 Timing Plan: P.M. Peak

												
Movement	EBL	EBT	EBR	WBL	WBT	WBR	NBL	NBT	NBR	SBL	SBT	SBR
Lane Configurations												
Traffic Volume (veh/h)	317	188	586	44	198	38	611	559	44	51	538	265
Future Volume (veh/h)	317	188	586	44	198	38	611	559	44	51	538	265
Initial Q (Qb), veh	0	0	0	0	0	0	0	0	0	0	0	0
Ped-Bike Adj(A_pbT)	1.00		1.00	1.00		1.00	1.00		0.98	1.00		0.98
Parking Bus, Adj	1.00	1.00	1.00	1.00	1.00	1.00	1.00	1.00	1.00	1.00	1.00	1.00
Work Zone On Approach		No			No			No			No	
Adj Sat Flow, veh/h/ln	1870	1870	1870	1870	1870	1870	1870	1870	1870	1870	1870	1870
Adj Flow Rate, veh/h	317	188	586	44	198	38	611	559	44	51	538	265
Peak Hour Factor	1.00	1.00	1.00	1.00	1.00	1.00	1.00	1.00	1.00	1.00	1.00	1.00
Percent Heavy Veh, %	2	2	2	2	2	2	2	2	2	2	2	2
Cap, veh/h	352	582	814	58	274	231	702	874	723	66	564	470
Arrive On Green	0.20	0.31	0.31	0.03	0.15	0.15	0.20	0.47	0.47	0.04	0.30	0.30
Sat Flow, veh/h	1781	1870	1583	1781	1870	1580	3456	1870	1546	1781	1870	1561
Grp Volume(v), veh/h	317	188	586	44	198	38	611	559	44	51	538	265
Grp Sat Flow(s),veh/h/ln	1781	1870	1583	1781	1870	1580	1728	1870	1546	1781	1870	1561
Q Serve(g_s), s	20.0	8.9	33.0	2.8	11.7	2.4	19.7	26.2	1.8	3.3	32.5	16.5
Cycle Q Clear(g_c), s	20.0	8.9	33.0	2.8	11.7	2.4	19.7	26.2	1.8	3.3	32.5	16.5
Prop In Lane	1.00		1.00	1.00		1.00	1.00		1.00	1.00		1.00
Lane Grp Cap(c), veh/h	352	582	814	58	274	231	702	874	723	66	564	470
V/C Ratio(X)	0.90	0.32	0.72	0.75	0.72	0.16	0.87	0.64	0.06	0.77	0.95	0.56
Avail Cap(c_a), veh/h	528	608	836	587	670	565	959	874	723	247	567	474
HCM Platoon Ratio	1.00	1.00	1.00	1.00	1.00	1.00	1.00	1.00	1.00	1.00	1.00	1.00
Upstream Filter(I)	1.00	1.00	1.00	1.00	1.00	1.00	1.00	1.00	1.00	1.00	1.00	1.00
Uniform Delay (d), s/veh	45.2	30.4	21.6	55.3	47.0	43.1	44.5	23.3	16.8	55.1	39.5	33.9
Incr Delay (d2), s/veh	13.4	0.3	2.9	17.6	3.6	0.3	6.7	1.6	0.0	16.9	26.7	1.5
Initial Q Delay(d3),s/veh	0.0	0.0	0.0	0.0	0.0	0.0	0.0	0.0	0.0	0.0	0.0	0.0
%ile BackOfQ(50%),veh/ln	9.9	4.0	11.8	1.5	5.6	0.9	8.8	11.1	0.6	1.8	18.6	6.2
Unsig. Movement Delay, s/veh												
LnGrp Delay(d),s/veh	58.6	30.8	24.6	73.0	50.6	43.4	51.2	24.9	16.9	72.0	66.2	35.4
LnGrp LOS	E	C	C	E	D	D	D	C	B	E	E	D
Approach Vol, veh/h		1091			280			1214			854	
Approach Delay, s/veh		35.5			53.1			37.8			57.0	
Approach LOS		D			D			D			E	
Timer - Assigned Phs	1	2	3	4	5	6	7	8				
Phs Duration (G+Y+Rc), s	8.3	40.4	27.4	39.3	27.3	21.4	8.3	58.4				
Change Period (Y+Rc), s	4.5	4.5	4.0	4.5	4.5	4.5	4.0	4.5				
Max Green Setting (Gmax), s	38.0	37.5	32.0	35.0	34.2	41.3	16.0	51.0				
Max Q Clear Time (g_c+I1), s	4.8	35.0	21.7	34.5	22.0	13.7	5.3	28.2				
Green Ext Time (p_c), s	0.1	0.9	1.7	0.2	0.7	1.1	0.1	3.5				
<b>Intersection Summary</b>												
HCM 6th Ctrl Delay			43.1									
HCM 6th LOS			D									



HCM 6th Signalized Intersection Summary  
2: Shiloh Road & Hembree Ln

GP 2040+Project Alternative C\_Mitigations  
Timing Plan: P.M. Peak



Movement	EBL	EBT	EBR	WBL	WBT	WBR	NBL	NBT	NBR	SBL	SBT	SBR
Lane Configurations	↖ ↗	↑ ↗		↖ ↗	↑ ↗		↖ ↗	↑ ↗		↖ ↗	↑ ↗	↖ ↗
Traffic Volume (veh/h)	661	888	69	110	846	118	111	21	128	174	11	526
Future Volume (veh/h)	661	888	69	110	846	118	111	21	128	174	11	526
Initial Q (Qb), veh	0	0	0	0	0	0	0	0	0	0	0	0
Ped-Bike Adj(A_pbT)	1.00		1.00	1.00		1.00	1.00		1.00	1.00		1.00
Parking Bus, Adj	1.00	1.00	1.00	1.00	1.00	1.00	1.00	1.00	1.00	1.00	1.00	1.00
Work Zone On Approach		No		No		No		No		No		No
Adj Sat Flow, veh/h/ln	1870	1870	1870	1870	1870	1870	1870	1870	1870	1870	1870	1870
Adj Flow Rate, veh/h	703	945	69	110	972	136	111	21	128	183	11	554
Peak Hour Factor	0.94	0.94	1.00	1.00	0.87	0.87	1.00	1.00	1.00	0.95	1.00	0.95
Percent Heavy Veh, %	2	2	2	2	2	2	2	2	2	2	2	2
Cap, veh/h	802	1782	130	141	1181	165	152	18	113	222	225	983
Arrive On Green	0.23	0.53	0.53	0.08	0.38	0.38	0.09	0.08	0.08	0.12	0.12	0.12
Sat Flow, veh/h	3456	3358	245	1781	3130	438	1781	228	1392	1781	1870	2790
Grp Volume(v), veh/h	703	500	514	110	552	556	111	0	149	183	11	554
Grp Sat Flow(s),veh/h/ln	1728	1777	1826	1781	1777	1791	1781	0	1620	1781	1870	1395
Q Serve(g_s), s	17.0	15.9	15.9	5.2	24.3	24.3	5.3	0.0	7.0	8.7	0.5	10.4
Cycle Q Clear(g_c), s	17.0	15.9	15.9	5.2	24.3	24.3	5.3	0.0	7.0	8.7	0.5	10.4
Prop In Lane	1.00		0.13	1.00		0.24	1.00		0.86	1.00		1.00
Lane Grp Cap(c), veh/h	802	943	969	141	671	676	152	0	131	222	225	983
V/C Ratio(X)	0.88	0.53	0.53	0.78	0.82	0.82	0.73	0.00	1.14	0.82	0.05	0.56
Avail Cap(c_a), veh/h	919	1051	1080	264	842	849	264	0	131	268	225	983
HCM Platoon Ratio	1.00	1.00	1.00	1.00	1.00	1.00	1.00	1.00	1.00	1.00	1.00	1.00
Upstream Filter(I)	1.00	1.00	1.00	1.00	1.00	1.00	1.00	0.00	1.00	1.00	1.00	1.00
Uniform Delay (d), s/veh	32.0	13.3	13.3	39.1	24.3	24.3	38.6	0.0	39.8	37.0	33.7	22.6
Incr Delay (d2), s/veh	8.7	0.5	0.5	9.1	5.4	5.3	6.6	0.0	120.2	16.0	0.1	0.7
Initial Q Delay(d3),s/veh	0.0	0.0	0.0	0.0	0.0	0.0	0.0	0.0	0.0	0.0	0.0	0.0
%ile BackOfQ(50%),veh/ln	7.6	5.7	5.8	2.6	10.3	10.4	2.5	0.0	7.1	4.6	0.2	4.5
Unsig. Movement Delay, s/veh												
LnGrp Delay(d),s/veh	40.7	13.7	13.7	48.2	29.7	29.7	45.2	0.0	159.9	52.9	33.8	23.4
LnGrp LOS	D	B	B	D	C	C	D	A	F	D	C	C
Approach Vol, veh/h		1717			1218			260			748	
Approach Delay, s/veh		24.8			31.4			111.0			30.8	
Approach LOS		C			C			F			C	
Timer - Assigned Phs	1	2	3	4	5	6	7	8				
Phs Duration (G+Y+Rc), s	10.8	49.9	11.4	14.4	24.1	36.7	14.8	11.0				
Change Period (Y+Rc), s	4.0	4.0	4.0	4.0	4.0	4.0	4.0	4.0				
Max Green Setting (Gmax), s	12.8	51.2	12.8	7.2	23.0	41.0	13.0	7.0				
Max Q Clear Time (g_c+1), s	17.2	17.9	7.3	12.4	19.0	26.3	10.7	9.0				
Green Ext Time (p_c), s	0.1	7.2	0.1	0.0	1.1	6.1	0.1	0.0				
<b>Intersection Summary</b>												
HCM 6th Ctrl Delay												33.6
HCM 6th LOS												C

Intersection						
Int Delay, s/veh	2.5					
Movement	EBT	EBR	WBL	WBT	NBL	NBR
Lane Configurations	↑↑		↖	↑↑	↖	↖
Traffic Vol, veh/h	1184	16	105	1123	18	159
Future Vol, veh/h	1184	16	105	1123	18	159
Conflicting Peds, #/hr	0	0	0	0	0	0
Sign Control	Free	Free	Free	Free	Stop	Stop
RT Channelized	-	None	-	None	-	None
Storage Length	-	-	68	-	0	0
Veh in Median Storage, #	0	-	-	0	0	-
Grade, %	0	-	-	0	0	-
Peak Hour Factor	100	100	100	100	100	100
Heavy Vehicles, %	2	2	2	2	2	2
Mvmt Flow	1184	16	105	1123	18	159

Major/Minor	Major1	Major2	Minor1		
Conflicting Flow All	0	0	1200	0	1964
Stage 1	-	-	-	-	1192
Stage 2	-	-	-	-	772
Critical Hdwy	-	-	4.14	-	6.84
Critical Hdwy Stg 1	-	-	-	-	5.84
Critical Hdwy Stg 2	-	-	-	-	5.84
Follow-up Hdwy	-	-	2.22	-	3.52
Pot Cap-1 Maneuver	-	-	577	-	55
Stage 1	-	-	-	-	250
Stage 2	-	-	-	-	416
Platoon blocked, %	-	-	-	-	-
Mov Cap-1 Maneuver	-	-	577	-	45
Mov Cap-2 Maneuver	-	-	-	-	45
Stage 1	-	-	-	-	250
Stage 2	-	-	-	-	340

Approach	EB	WB	NB
HCM Control Delay, s	0	1.1	29.1
HCM LOS			D

Minor Lane/Major Mvmt	NBLn1	NBLn2	EBT	EBR	WBL	WBT
Capacity (veh/h)	45	444	-	-	577	-
HCM Lane V/C Ratio	0.4	0.358	-	-	0.182	-
HCM Control Delay (s)	130.6	17.6	-	-	12.6	-
HCM Lane LOS	F	C	-	-	B	-
HCM 95th %tile Q(veh)	1.4	1.6	-	-	0.7	-

HCM Signalized Intersection Capacity Analysis  
6: Conde Lane & Shiloh Road

GP 2040+Project Alternative C\_Mitigations  
Timing Plan: P.M. Peak

Movement	EBL	EBT	EBR	WBL	WBT	WBR	NBL	NBT	NBR	SBL	SBT	SBR
Lane Configurations												
Traffic Volume (vph)	77	707	0	9	727	372	4	2	16	387	4	65
Future Volume (vph)	77	707	0	9	727	372	4	2	16	387	4	65
Ideal Flow (vphpl)	1900	1900	1900	1900	1900	1900	1900	1900	1900	1900	1900	1900
Total Lost time (s)	4.0	4.0		4.0	4.0			4.0			4.0	4.0
Lane Util. Factor	1.00	0.95		1.00	0.95			1.00			1.00	1.00
Frbp, ped/bikes	1.00	1.00		1.00	0.99			1.00			1.00	1.00
Flpb, ped/bikes	1.00	1.00		1.00	1.00			1.00			1.00	1.00
Frt	1.00	1.00		1.00	0.95			0.90			1.00	0.85
Flt Protected	0.95	1.00		0.95	1.00			0.99			0.95	1.00
Satd. Flow (prot)	1770	3539		1770	3335			1665			1775	1583
Flt Permitted	0.95	1.00		0.95	1.00			0.99			0.95	1.00
Satd. Flow (perm)	1770	3539		1770	3335			1665			1775	1583
Peak-hour factor, PHF	1.00	1.00	1.00	1.00	1.00	1.00	1.00	1.00	1.00	1.00	1.00	1.00
Adj. Flow (vph)	77	707	0	9	727	372	4	2	16	387	4	65
RTOR Reduction (vph)	0	0	0	0	48	0	0	15	0	0	0	0
Lane Group Flow (vph)	77	707	0	9	1051	0	0	7	0	0	391	65
Confl. Peds. (#/hr)	1					1						
Turn Type	Prot	NA		Prot	NA		Split	NA		Split	NA	custom
Protected Phases	5	2		1	6		7	7		4	4	
Permitted Phases												6
Actuated Green, G (s)	6.0	39.4		1.3	34.7			3.2			22.5	34.7
Effective Green, g (s)	6.0	39.4		1.3	34.7			3.2			22.5	34.7
Actuated g/C Ratio	0.07	0.48		0.02	0.42			0.04			0.27	0.42
Clearance Time (s)	4.0	4.0		4.0	4.0			4.0			4.0	4.0
Vehicle Extension (s)	3.0	3.0		3.0	3.0			3.0			3.0	3.0
Lane Grp Cap (vph)	128	1692		27	1404			64			484	666
v/s Ratio Prot	c0.04	0.20		0.01	c0.32			c0.00			c0.22	
v/s Ratio Perm												0.04
v/c Ratio	0.60	0.42		0.33	0.75			0.10			0.81	0.10
Uniform Delay, d1	37.0	14.0		40.1	20.2			38.2			27.9	14.4
Progression Factor	1.00	1.00		1.00	1.00			1.00			1.00	1.00
Incremental Delay, d2	7.7	0.2		7.2	2.2			0.7			9.6	0.1
Delay (s)	44.8	14.2		47.3	22.4			38.9			37.5	14.5
Level of Service	D	B		D	C			D			D	B
Approach Delay (s)		17.2			22.6			38.9			34.2	
Approach LOS		B			C			D			C	
<b>Intersection Summary</b>												
HCM 2000 Control Delay			23.2			HCM 2000 Level of Service				C		
HCM 2000 Volume to Capacity ratio			0.72									
Actuated Cycle Length (s)			82.4			Sum of lost time (s)			16.0			
Intersection Capacity Utilization			77.0%			ICU Level of Service			D			
Analysis Period (min)			15									
c	Critical Lane Group											

HCM 6th Signalized Intersection Summary  
8: Old Redwood Hwy & Entrance 1

GP 2040+Project Alternative C\_Mitigations  
Timing Plan: P.M. Peak



Movement	EBL	EBT	EBR	WBL	WBT	WBR	NBL	NBT	NBR	SBL	SBT	SBR
Lane Configurations		↕		↖	↗			↕		↖	↗	
Traffic Volume (veh/h)	4	0	0	9	0	15	0	1195	10	16	1152	0
Future Volume (veh/h)	4	0	0	9	0	15	0	1195	10	16	1152	0
Initial Q (Qb), veh	0	0	0	0	0	0	0	0	0	0	0	0
Ped-Bike Adj(A_pbT)	1.00		1.00	1.00		1.00	1.00		0.99	1.00		1.00
Parking Bus, Adj	1.00	1.00	1.00	1.00	1.00	1.00	1.00	1.00	1.00	1.00	1.00	1.00
Work Zone On Approach		No			No			No			No	
Adj Sat Flow, veh/h/ln	1870	1870	1870	1870	1870	1870	1870	1870	1870	1870	1870	1870
Adj Flow Rate, veh/h	11	0	0	9	0	15	0	1313	11	17	1226	0
Peak Hour Factor	0.38	0.38	0.38	1.00	1.00	1.00	0.91	0.91	0.91	0.94	0.94	0.94
Percent Heavy Veh, %	2	2	2	2	2	2	2	2	2	2	2	2
Cap, veh/h	187	0	0	206	0	111	0	1449	12	206	1463	0
Arrive On Green	0.07	0.00	0.00	0.07	0.00	0.07	0.00	0.78	0.78	0.78	0.78	0.00
Sat Flow, veh/h	1221	0	0	1418	0	1585	0	1852	16	414	1870	0
Grp Volume(v), veh/h	11	0	0	9	0	15	0	0	1324	17	1226	0
Grp Sat Flow(s),veh/h/ln	1221	0	0	1418	0	1585	0	0	1867	414	1870	0
Q Serve(g_s), s	0.5	0.0	0.0	0.0	0.0	0.6	0.0	0.0	37.8	2.3	29.5	0.0
Cycle Q Clear(g_c), s	1.2	0.0	0.0	0.3	0.0	0.6	0.0	0.0	37.8	40.0	29.5	0.0
Prop In Lane	1.00		0.00	1.00		1.00	0.00		0.01	1.00		0.00
Lane Grp Cap(c), veh/h	187	0	0	206	0	111	0	0	1461	206	1463	0
V/C Ratio(X)	0.06	0.00	0.00	0.04	0.00	0.13	0.00	0.00	0.91	0.08	0.84	0.00
Avail Cap(c_a), veh/h	442	0	0	465	0	401	0	0	1875	297	1878	0
HCM Platoon Ratio	1.00	1.00	1.00	1.00	1.00	1.00	1.00	1.00	1.00	1.00	1.00	1.00
Upstream Filter(I)	1.00	0.00	0.00	1.00	0.00	1.00	0.00	0.00	1.00	1.00	1.00	0.00
Uniform Delay (d), s/veh	31.6	0.0	0.0	30.9	0.0	31.1	0.0	0.0	5.8	20.8	4.9	0.0
Incr Delay (d2), s/veh	0.1	0.0	0.0	0.1	0.0	0.5	0.0	0.0	5.7	0.2	2.8	0.0
Initial Q Delay(d3),s/veh	0.0	0.0	0.0	0.0	0.0	0.0	0.0	0.0	0.0	0.0	0.0	0.0
%ile BackOfQ(50%),veh/ln	0.2	0.0	0.0	0.1	0.0	0.3	0.0	0.0	5.6	0.2	3.8	0.0
Unsig. Movement Delay, s/veh												
LnGrp Delay(d),s/veh	31.8	0.0	0.0	31.0	0.0	31.6	0.0	0.0	11.5	20.9	7.7	0.0
LnGrp LOS	C	A	A	C	A	C	A	A	B	C	A	A
Approach Vol, veh/h		11			24			1324			1243	
Approach Delay, s/veh		31.8			31.4			11.5			7.9	
Approach LOS		C			C			B			A	
Timer - Assigned Phs		2		4		6		8				
Phs Duration (G+Y+Rc), s		61.5		9.7		61.5		9.7				
Change Period (Y+Rc), s		5.8		* 4.7		5.8		* 4.7				
Max Green Setting (Gmax), s		71.5		* 18		71.5		* 18				
Max Q Clear Time (g_c+I1), s		39.8		3.2		42.0		2.6				
Green Ext Time (p_c), s		16.0		0.0		13.3		0.0				

Intersection Summary

HCM 6th Ctrl Delay	10.0
HCM 6th LOS	B

Notes

\* HCM 6th computational engine requires equal clearance times for the phases crossing the barrier.

HCM 6th Signalized Intersection Summary  
 1: Old Redwood Hwy & Shiloh Road

GP 2040+Project Alternative C\_Mitigations  
 Timing Plan: Saturday Midday Peak

Movement	EBL	EBT	EBR	WBL	WBT	WBR	NBL	NBT	NBR	SBL	SBT	SBR
Lane Configurations												
Traffic Volume (veh/h)	182	209	240	31	222	37	248	342	35	44	275	266
Future Volume (veh/h)	182	209	240	31	222	37	248	342	35	44	275	266
Initial Q (Qb), veh	0	0	0	0	0	0	0	0	0	0	0	0
Ped-Bike Adj(A_pbT)	1.00		0.97	1.00		1.00	1.00		0.98	1.00		0.98
Parking Bus, Adj	1.00	1.00	1.00	1.00	1.00	1.00	1.00	1.00	1.00	1.00	1.00	1.00
Work Zone On Approach		No			No			No			No	
Adj Sat Flow, veh/h/ln	1870	1870	1870	1870	1870	1870	1870	1870	1870	1870	1870	1870
Adj Flow Rate, veh/h	204	235	270	36	258	43	267	368	38	48	302	292
Peak Hour Factor	0.89	0.89	0.89	0.86	0.86	0.86	0.93	0.93	0.93	0.91	0.91	0.91
Percent Heavy Veh, %	2	2	2	2	2	2	2	2	2	2	2	2
Cap, veh/h	269	505	416	146	376	319	386	524	434	146	468	390
Arrive On Green	0.15	0.27	0.27	0.08	0.20	0.20	0.11	0.28	0.28	0.08	0.25	0.25
Sat Flow, veh/h	1781	1870	1540	1781	1870	1585	3456	1870	1551	1781	1870	1559
Grp Volume(v), veh/h	204	235	270	36	258	43	267	368	38	48	302	292
Grp Sat Flow(s),veh/h/ln	1781	1870	1540	1781	1870	1585	1728	1870	1551	1781	1870	1559
Q Serve(g_s), s	6.7	6.4	9.5	1.2	7.8	1.4	4.5	10.8	1.1	1.6	8.8	10.6
Cycle Q Clear(g_c), s	6.7	6.4	9.5	1.2	7.8	1.4	4.5	10.8	1.1	1.6	8.8	10.6
Prop In Lane	1.00		1.00	1.00		1.00	1.00		1.00	1.00		1.00
Lane Grp Cap(c), veh/h	269	505	416	146	376	319	386	524	434	146	468	390
V/C Ratio(X)	0.76	0.46	0.65	0.25	0.69	0.13	0.69	0.70	0.09	0.33	0.65	0.75
Avail Cap(c_a), veh/h	874	994	818	1107	1239	1050	565	1285	1066	146	1132	943
HCM Platoon Ratio	1.00	1.00	1.00	1.00	1.00	1.00	1.00	1.00	1.00	1.00	1.00	1.00
Upstream Filter(I)	1.00	1.00	1.00	1.00	1.00	1.00	1.00	1.00	1.00	1.00	1.00	1.00
Uniform Delay (d), s/veh	24.9	18.6	19.7	26.3	22.6	20.1	26.1	19.7	16.2	26.5	20.5	21.2
Incr Delay (d2), s/veh	4.4	0.7	1.7	0.9	2.2	0.2	2.2	1.7	0.1	1.3	1.5	2.9
Initial Q Delay(d3),s/veh	0.0	0.0	0.0	0.0	0.0	0.0	0.0	0.0	0.0	0.0	0.0	0.0
%ile BackOfQ(50%),veh/ln	2.9	2.5	3.1	0.5	3.3	0.5	1.8	4.2	0.3	0.7	3.6	3.6
Unsig. Movement Delay, s/veh												
LnGrp Delay(d),s/veh	29.2	19.3	21.5	27.2	24.9	20.3	28.4	21.5	16.3	27.8	22.0	24.1
LnGrp LOS	C	B	C	C	C	C	C	C	B	C	C	C
Approach Vol, veh/h		709			337			673			642	
Approach Delay, s/veh		23.0			24.5			23.9			23.4	
Approach LOS		C			C			C			C	
Timer - Assigned Phs	1	2	3	4	5	6	7	8				
Phs Duration (G+Y+Rc), s	9.5	21.0	10.8	19.8	13.7	16.8	9.0	21.6				
Change Period (Y+Rc), s	4.5	4.5	4.0	4.5	4.5	4.5	4.0	4.5				
Max Green Setting (Gmax), s	38.0	32.5	10.0	37.0	30.0	40.5	5.0	42.0				
Max Q Clear Time (g_c+I1), s	3.2	11.5	6.5	12.6	8.7	9.8	3.6	12.8				
Green Ext Time (p_c), s	0.1	2.1	0.3	2.7	0.5	1.6	0.0	2.2				
<b>Intersection Summary</b>												
HCM 6th Ctrl Delay				23.6								
HCM 6th LOS				C								

HCM 6th Signalized Intersection Summary  
2: Shiloh Road & Hembree Ln

GP 2040+Project Alternative C\_Mitigations  
Timing Plan: Saturday Midday Peak



Movement	EBL	EBT	EBR	WBL	WBT	WBR	NBL	NBT	NBR	SBL	SBT	SBR
Lane Configurations	↖↗	↕		↖↗	↕		↖	↗		↖	↕	↗↖
Traffic Volume (veh/h)	918	500	69	110	442	235	111	21	128	236	11	856
Future Volume (veh/h)	918	500	69	110	442	235	111	21	128	236	11	856
Initial Q (Qb), veh	0	0	0	0	0	0	0	0	0	0	0	0
Ped-Bike Adj(A_pbT)	1.00		1.00	1.00		1.00	1.00		1.00	1.00		1.00
Parking Bus, Adj	1.00	1.00	1.00	1.00	1.00	1.00	1.00	1.00	1.00	1.00	1.00	1.00
Work Zone On Approach		No		No		No		No		No		No
Adj Sat Flow, veh/h/ln	1870	1870	1870	1870	1870	1870	1870	1870	1870	1870	1870	1870
Adj Flow Rate, veh/h	918	500	69	110	442	235	111	21	128	236	11	856
Peak Hour Factor	1.00	1.00	1.00	1.00	1.00	1.00	1.00	1.00	1.00	1.00	1.00	1.00
Percent Heavy Veh, %	2	2	2	2	2	2	2	2	2	2	2	2
Cap, veh/h	1029	1522	209	142	600	316	157	16	99	278	261	1219
Arrive On Green	0.30	0.49	0.49	0.08	0.27	0.27	0.09	0.07	0.07	0.16	0.14	0.14
Sat Flow, veh/h	3456	3138	431	1781	2247	1185	1781	228	1392	1781	1870	2790
Grp Volume(v), veh/h	918	282	287	110	349	328	111	0	149	236	11	856
Grp Sat Flow(s),veh/h/ln	1728	1777	1792	1781	1777	1656	1781	0	1620	1781	1870	1395
Q Serve(g_s), s	19.5	7.5	7.5	4.7	13.8	14.0	4.7	0.0	5.5	9.9	0.4	10.7
Cycle Q Clear(g_c), s	19.5	7.5	7.5	4.7	13.8	14.0	4.7	0.0	5.5	9.9	0.4	10.7
Prop In Lane	1.00		0.24	1.00		0.72	1.00		0.86	1.00		1.00
Lane Grp Cap(c), veh/h	1029	862	869	142	474	442	157	0	116	278	261	1219
V/C Ratio(X)	0.89	0.33	0.33	0.78	0.74	0.74	0.71	0.00	1.29	0.85	0.04	0.70
Avail Cap(c_a), veh/h	1127	1217	1228	296	933	869	296	0	116	301	261	1219
HCM Platoon Ratio	1.00	1.00	1.00	1.00	1.00	1.00	1.00	1.00	1.00	1.00	1.00	1.00
Upstream Filter(I)	1.00	1.00	1.00	1.00	1.00	1.00	1.00	0.00	1.00	1.00	1.00	1.00
Uniform Delay (d), s/veh	25.8	12.1	12.1	34.7	25.7	25.8	34.1	0.0	35.7	31.6	28.7	17.6
Incr Delay (d2), s/veh	8.7	0.2	0.2	8.7	2.2	2.5	5.7	0.0	179.2	18.9	0.1	1.8
Initial Q Delay(d3),s/veh	0.0	0.0	0.0	0.0	0.0	0.0	0.0	0.0	0.0	0.0	0.0	0.0
%ile BackOfQ(50%),veh/ln	8.5	2.6	2.7	2.3	5.6	5.4	2.2	0.0	7.9	5.5	0.2	5.9
Unsig. Movement Delay, s/veh												
LnGrp Delay(d),s/veh	34.5	12.3	12.4	43.5	28.0	28.3	39.8	0.0	215.0	50.5	28.7	19.4
LnGrp LOS	C	B	B	D	C	C	D	A	F	D	C	B
Approach Vol, veh/h		1487			787			260			1103	
Approach Delay, s/veh		26.0			30.3			140.2			26.2	
Approach LOS		C			C			F			C	
Timer - Assigned Phs	1	2	3	4	5	6	7	8				
Phs Duration (G+Y+Rc), s	10.1	41.3	10.8	14.7	26.9	24.5	16.0	9.5				
Change Period (Y+Rc), s	4.0	4.0	4.0	4.0	4.0	4.0	4.0	4.0				
Max Green Setting (Gmax), s	12.8	52.7	12.8	5.7	25.1	40.4	13.0	5.5				
Max Q Clear Time (g_c+1/3), s	10.7	9.5	6.7	12.7	21.5	16.0	11.9	7.5				
Green Ext Time (p_c), s	0.1	3.5	0.1	0.0	1.4	4.2	0.1	0.0				

Intersection Summary

HCM 6th Ctrl Delay	35.2
HCM 6th LOS	D

HCM 6th Signalized Intersection Summary  
 3: US 101 NB Off-Ramp & Shiloh Road

GP 2040+Project Alternative C\_Mitigations  
 Timing Plan: Saturday Midday Peak

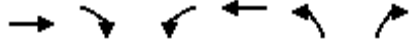

Movement	EBT	EBR	WBL	WBT	NBL	NBR
Lane Configurations	↑↑			↑↑	↘	↗
Traffic Volume (veh/h)	574	0	0	997	520	842
Future Volume (veh/h)	574	0	0	997	520	842
Initial Q (Qb), veh	0	0	0	0	0	0
Ped-Bike Adj(A_pbT)		1.00	1.00		1.00	1.00
Parking Bus, Adj	1.00	1.00	1.00	1.00	1.00	1.00
Work Zone On Approach	No			No	No	
Adj Sat Flow, veh/h/ln	1870	0	0	1870	1870	1870
Adj Flow Rate, veh/h	631	0	0	1120	547	886
Peak Hour Factor	0.91	0.91	0.89	0.89	0.95	0.95
Percent Heavy Veh, %	2	0	0	2	2	2
Cap, veh/h	1427	0	0	1427	706	1106
Arrive On Green	0.40	0.00	0.00	0.40	0.40	0.40
Sat Flow, veh/h	3741	0	0	3741	1781	2790
Grp Volume(v), veh/h	631	0	0	1120	547	886
Grp Sat Flow(s),veh/h/ln	1777	0	0	1777	1781	1395
Q Serve(g_s), s	5.8	0.0	0.0	12.3	11.9	12.5
Cycle Q Clear(g_c), s	5.8	0.0	0.0	12.3	11.9	12.5
Prop In Lane		0.00	0.00		1.00	1.00
Lane Grp Cap(c), veh/h	1427	0	0	1427	706	1106
V/C Ratio(X)	0.44	0.00	0.00	0.78	0.77	0.80
Avail Cap(c_a), veh/h	1635	0	0	1635	820	1284
HCM Platoon Ratio	1.00	1.00	1.00	1.00	1.00	1.00
Upstream Filter(I)	1.00	0.00	0.00	1.00	1.00	1.00
Uniform Delay (d), s/veh	9.7	0.0	0.0	11.6	11.7	11.9
Incr Delay (d2), s/veh	0.2	0.0	0.0	2.3	4.0	3.3
Initial Q Delay(d3),s/veh	0.0	0.0	0.0	0.0	0.0	0.0
%ile BackOfQ(50%),veh/ln	1.6	0.0	0.0	3.8	4.4	3.5
Unsig. Movement Delay, s/veh						
LnGrp Delay(d),s/veh	9.9	0.0	0.0	13.9	15.7	15.1
LnGrp LOS	A	A	A	B	B	B
Approach Vol, veh/h	631			1120	1433	
Approach Delay, s/veh	9.9			13.9	15.4	
Approach LOS	A			B	B	
Timer - Assigned Phs		2			6	8
Phs Duration (G+Y+Rc), s		22.4			22.4	22.2
Change Period (Y+Rc), s		4.5			4.5	4.5
Max Green Setting (Gmax), s		20.5			20.5	20.5
Max Q Clear Time (g_c+I1), s		7.8			14.3	14.5
Green Ext Time (p_c), s		3.2			3.6	3.1
<b>Intersection Summary</b>						
HCM 6th Ctrl Delay			13.8			
HCM 6th LOS			B			

Intersection						
Int Delay, s/veh	2.8					
Movement	EBT	EBR	WBL	WBT	NBL	NBR
Lane Configurations	↑↑		↘	↑↑	↘	↘
Traffic Vol, veh/h	801	30	120	887	24	115
Future Vol, veh/h	801	30	120	887	24	115
Conflicting Peds, #/hr	0	0	0	0	1	0
Sign Control	Free	Free	Free	Free	Stop	Stop
RT Channelized	-	None	-	None	-	None
Storage Length	-	-	68	-	0	0
Veh in Median Storage, #	0	-	-	0	0	-
Grade, %	0	-	-	0	0	-
Peak Hour Factor	92	92	87	87	78	78
Heavy Vehicles, %	2	2	2	2	2	2
Mvmt Flow	871	33	138	1020	31	147

Major/Minor	Major1	Major2	Minor1		
Conflicting Flow All	0	0	904	0	1675 452
Stage 1	-	-	-	-	888 -
Stage 2	-	-	-	-	787 -
Critical Hdwy	-	-	4.14	-	6.84 6.94
Critical Hdwy Stg 1	-	-	-	-	5.84 -
Critical Hdwy Stg 2	-	-	-	-	5.84 -
Follow-up Hdwy	-	-	2.22	-	3.52 3.32
Pot Cap-1 Maneuver	-	-	748	-	86 555
Stage 1	-	-	-	-	362 -
Stage 2	-	-	-	-	409 -
Platoon blocked, %	-	-	-	-	-
Mov Cap-1 Maneuver	-	-	748	-	70 555
Mov Cap-2 Maneuver	-	-	-	-	70 -
Stage 1	-	-	-	-	362 -
Stage 2	-	-	-	-	333 -

Approach	EB	WB	NB
HCM Control Delay, s	0	1.3	27.3
HCM LOS			D

Minor Lane/Major Mvmt	NBLn1	NBLn2	EBT	EBR	WBL	WBT
Capacity (veh/h)	70	555	-	-	748	-
HCM Lane V/C Ratio	0.44	0.266	-	-	0.184	-
HCM Control Delay (s)	91.8	13.8	-	-	10.9	-
HCM Lane LOS	F	B	-	-	B	-
HCM 95th %tile Q(veh)	1.7	1.1	-	-	0.7	-



Intersection												
Int Delay, s/veh	4.4											
Movement	EBL	EBT	EBR	WBL	WBT	WBR	NBL	NBT	NBR	SBL	SBT	SBR
Lane Configurations		↕			↕		↕	↕			↕	
Traffic Vol, veh/h	30	157	118	8	135	0	133	0	9	0	0	27
Future Vol, veh/h	30	157	118	8	135	0	133	0	9	0	0	27
Conflicting Peds, #/hr	1	0	0	0	0	0	0	0	0	0	0	0
Sign Control	Free	Free	Free	Free	Free	Free	Stop	Stop	Stop	Stop	Stop	Stop
RT Channelized	-	-	None	-	-	None	-	-	None	-	-	None
Storage Length	-	-	-	-	-	-	0	-	-	-	-	-
Veh in Median Storage, #	-	0	-	-	0	-	-	0	-	-	0	-
Grade, %	-	0	-	-	0	-	-	0	-	-	0	-
Peak Hour Factor	93	93	93	88	88	88	100	100	100	56	56	56
Heavy Vehicles, %	2	2	2	2	2	2	2	2	2	2	2	2
Mvmt Flow	32	169	127	9	153	0	133	0	9	0	0	48

Major/Minor	Major1			Major2			Minor1			Minor2		
Conflicting Flow All	154	0	0	296	0	0	492	469	233	473	532	154
Stage 1	-	-	-	-	-	-	297	297	-	172	172	-
Stage 2	-	-	-	-	-	-	195	172	-	301	360	-
Critical Hdwy	4.12	-	-	4.12	-	-	7.12	6.52	6.22	7.12	6.52	6.22
Critical Hdwy Stg 1	-	-	-	-	-	-	6.12	5.52	-	6.12	5.52	-
Critical Hdwy Stg 2	-	-	-	-	-	-	6.12	5.52	-	6.12	5.52	-
Follow-up Hdwy	2.218	-	-	2.218	-	-	3.518	4.018	3.318	3.518	4.018	3.318
Pot Cap-1 Maneuver	1426	-	-	1265	-	-	487	492	806	501	453	892
Stage 1	-	-	-	-	-	-	712	668	-	830	756	-
Stage 2	-	-	-	-	-	-	807	756	-	708	626	-
Platoon blocked, %		-	-		-	-						
Mov Cap-1 Maneuver	1425	-	-	1265	-	-	449	474	806	482	437	891
Mov Cap-2 Maneuver	-	-	-	-	-	-	449	474	-	482	437	-
Stage 1	-	-	-	-	-	-	693	650	-	807	749	-
Stage 2	-	-	-	-	-	-	757	749	-	681	609	-

Approach	EB			WB			NB			SB		
HCM Control Delay, s	0.7			0.4			16			9.3		
HCM LOS							C			A		

Minor Lane/Major Mvmt	NBLn1	NBLn2	EBL	EBT	EBR	WBL	WBT	WBR	SBLn1
Capacity (veh/h)	449	806	1425	-	-	1265	-	-	891
HCM Lane V/C Ratio	0.296	0.011	0.023	-	-	0.007	-	-	0.054
HCM Control Delay (s)	16.4	9.5	7.6	0	-	7.9	0	-	9.3
HCM Lane LOS	C	A	A	A	-	A	A	-	A
HCM 95th %tile Q(veh)	1.2	0	0.1	-	-	0	-	-	0.2

HCM 6th Signalized Intersection Summary

GP 2040+Project Alternative C\_Mitigations

12: US 101 SB On Ramp/US 101 SB Off Ramp & Old Redwood Highway Timing Plan: Saturday Midday Peak



Movement	EBL	EBT	EBR	WBL	WBT	WBR	NBL	NBT	NBR	SBL	SBT	SBR	
Lane Configurations		↑↑	↑	↑	↑↑					↑	↔		
Traffic Volume (veh/h)	0	713	543	632	1060	0	0	0	0	213	1	112	
Future Volume (veh/h)	0	713	543	632	1060	0	0	0	0	213	1	112	
Initial Q (Qb), veh	0	0	0	0	0	0				0	0	0	
Ped-Bike Adj(A_pbT)	1.00		0.98	1.00		1.00				1.00		1.00	
Parking Bus, Adj	1.00	1.00	1.00	1.00	1.00	1.00				1.00	1.00	1.00	
Work Zone On Approach		No			No						No		
Adj Sat Flow, veh/h/ln	0	1870	1870	1870	1870	0				1870	1870	1870	
Adj Flow Rate, veh/h	0	735	560	658	1104	0				226	98	0	
Peak Hour Factor	0.97	0.97	0.97	0.96	0.96	0.96				0.72	0.72	0.72	
Percent Heavy Veh, %	0	2	2	2	2	0				2	2	2	
Cap, veh/h	0	1137	497	675	2663	0				265	278		
Arrive On Green	0.00	0.32	0.32	0.38	0.75	0.00				0.15	0.15	0.00	
Sat Flow, veh/h	0	3647	1552	1781	3647	0				1781	1870	0	
Grp Volume(v), veh/h	0	735	560	658	1104	0				226	98	0	
Grp Sat Flow(s),veh/h/ln	0	1777	1552	1781	1777	0				1781	1870	0	
Q Serve(g_s), s	0.0	15.7	28.3	32.2	10.0	0.0				10.9	4.2	0.0	
Cycle Q Clear(g_c), s	0.0	15.7	28.3	32.2	10.0	0.0				10.9	4.2	0.0	
Prop In Lane	0.00		1.00	1.00		0.00				1.00		0.00	
Lane Grp Cap(c), veh/h	0	1137	497	675	2663	0				265	278		
V/C Ratio(X)	0.00	0.65	1.13	0.98	0.41	0.00				0.85	0.35		
Avail Cap(c_a), veh/h	0	1137	497	675	2663	0				296	311		
HCM Platoon Ratio	1.00	1.00	1.00	1.00	1.00	1.00				1.00	1.00	1.00	
Upstream Filter(I)	0.00	1.00	1.00	1.00	1.00	0.00				1.00	1.00	0.00	
Uniform Delay (d), s/veh	0.0	25.8	30.1	27.1	4.0	0.0				36.7	33.8	0.0	
Incr Delay (d2), s/veh	0.0	2.8	80.4	28.5	0.5	0.0				19.2	0.8	0.0	
Initial Q Delay(d3),s/veh	0.0	0.0	0.0	0.0	0.0	0.0				0.0	0.0	0.0	
%ile BackOfQ(50%),veh/ln	0.0	6.7	21.0	18.0	2.6	0.0				6.1	1.9	0.0	
Unsig. Movement Delay, s/veh													
LnGrp Delay(d),s/veh	0.0	28.6	110.5	55.6	4.5	0.0				55.9	34.6	0.0	
LnGrp LOS		A	C	F	E	A				E	C		
Approach Vol, veh/h		1295				1762					324		
Approach Delay, s/veh		64.0				23.6					49.4		
Approach LOS		E				C					D		
Timer - Assigned Phs		2			5		6		8				
Phs Duration (G+Y+Rc), s		70.8			38.0		32.8		17.7				
Change Period (Y+Rc), s		4.5			4.5		4.5		4.5				
Max Green Setting (Gmax), s		66.3			33.5		28.3		14.7				
Max Q Clear Time (g_c+1), s		12.0			34.2		30.3		12.9				
Green Ext Time (p_c), s		10.4			0.0		0.0		0.2				

Intersection Summary

HCM 6th Ctrl Delay	41.5
HCM 6th LOS	D

Notes

- User approved volume balancing among the lanes for turning movement.
- User approved ignoring U-Turning movement.
- Unsignalized Delay for [SBR] is excluded from calculations of the approach delay and intersection delay.

Queues  
1: Old Redwood Hwy & Shiloh Road



Lane Group	EBL	EBT	EBR	WBL	WBT	WBR	NBL	NBT	NBR	SBL	SBT	SBR
Lane Group Flow (vph)	313	196	414	40	160	19	346	309	18	38	475	398
v/c Ratio	0.97	0.34	0.47	0.30	0.57	0.05	0.78	0.37	0.02	0.37	0.77	0.52
Control Delay	81.5	27.7	11.3	46.6	43.4	0.3	51.3	18.7	0.1	52.3	35.5	6.2
Queue Delay	0.0	0.0	0.0	0.0	0.0	0.0	0.0	0.0	0.0	0.0	0.0	0.0
Total Delay	81.5	27.7	11.3	46.6	43.4	0.3	51.3	18.7	0.1	52.3	35.5	6.2
Queue Length 50th (ft)	172	90	84	21	82	0	95	116	0	20	226	12
Queue Length 95th (ft)	#382	159	179	57	150	0	#186	198	0	56	367	80
Internal Link Dist (ft)		1709			528			668			695	
Turn Bay Length (ft)	425		200	200		50	430		98	190		220
Base Capacity (vph)	323	1004	876	142	814	789	445	882	822	104	747	845
Starvation Cap Reductn	0	0	0	0	0	0	0	0	0	0	0	0
Spillback Cap Reductn	0	0	0	0	0	0	0	0	0	0	0	0
Storage Cap Reductn	0	0	0	0	0	0	0	0	0	0	0	0
Reduced v/c Ratio	0.97	0.20	0.47	0.28	0.20	0.02	0.78	0.35	0.02	0.37	0.64	0.47

**Intersection Summary**

# 95th percentile volume exceeds capacity, queue may be longer.  
Queue shown is maximum after two cycles.

## Queues

## GP 2040+Project Alternative C\_Mitigations

## 2: Shiloh Road &amp; Hembree Ln

Timing Plan: A.M. PEAK



Lane Group	EBL	EBT	WBL	WBT	NBL	NBT	SBL	SBT	SBR
Lane Group Flow (vph)	353	987	49	882	49	27	137	18	606
v/c Ratio	0.57	0.48	0.24	0.64	0.18	0.14	0.52	0.07	0.49
Control Delay	29.1	9.2	31.1	15.7	27.1	21.9	36.7	29.1	10.3
Queue Delay	0.0	0.0	0.0	0.0	0.0	0.0	0.0	0.0	0.0
Total Delay	29.1	9.2	31.1	15.7	27.1	21.9	36.7	29.1	10.3
Queue Length 50th (ft)	46	48	13	100	13	3	36	4	25
Queue Length 95th (ft)	#147	190	56	190	56	30	#155	28	119
Internal Link Dist (ft)		222		1709		136		301	
Turn Bay Length (ft)			100				350		250
Base Capacity (vph)	649	2851	217	2675	278	190	268	264	1248
Starvation Cap Reductn	0	0	0	0	0	0	0	0	0
Spillback Cap Reductn	0	0	0	0	0	0	0	0	0
Storage Cap Reductn	0	0	0	0	0	0	0	0	0
Reduced v/c Ratio	0.54	0.35	0.23	0.33	0.18	0.14	0.51	0.07	0.49

## Intersection Summary

# 95th percentile volume exceeds capacity, queue may be longer.

Queue shown is maximum after two cycles.

Queues  
3: US 101 NB Off-Ramp & Shiloh Road

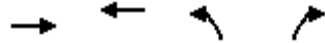

Lane Group	EBT	WBT	NBL	NBR
Lane Group Flow (vph)	743	1152	1070	680
v/c Ratio	0.65	1.00	1.05	0.41
Control Delay	26.2	55.6	62.6	9.0
Queue Delay	0.0	0.0	0.0	0.0
Total Delay	26.2	55.6	62.6	9.0
Queue Length 50th (ft)	165	~301	~593	83
Queue Length 95th (ft)	224	#444	#612	94
Internal Link Dist (ft)	106	291	689	
Turn Bay Length (ft)				340
Base Capacity (vph)	1150	1150	1017	1640
Starvation Cap Reductn	0	0	0	0
Spillback Cap Reductn	0	0	0	0
Storage Cap Reductn	0	0	0	0
Reduced v/c Ratio	0.65	1.00	1.05	0.41

Intersection Summary

- ~ Volume exceeds capacity, queue is theoretically infinite.  
Queue shown is maximum after two cycles.
- # 95th percentile volume exceeds capacity, queue may be longer.  
Queue shown is maximum after two cycles.

Queues  
6: Conde Lane & Shiloh Road

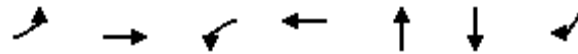

Lane Group	EBL	EBT	WBL	WBT	NBT	SBT	SBR
Lane Group Flow (vph)	55	529	8	1145	12	363	27
v/c Ratio	0.28	0.28	0.04	0.74	0.05	0.70	0.04
Control Delay	40.2	10.7	37.4	20.7	23.5	37.0	13.6
Queue Delay	0.0	0.0	0.0	0.0	0.0	0.0	0.0
Total Delay	40.2	10.7	37.4	20.7	23.5	37.0	13.6
Queue Length 50th (ft)	24	52	4	210	1	155	7
Queue Length 95th (ft)	72	151	19	379	19	#397	25
Internal Link Dist (ft)		735		1001	338	442	
Turn Bay Length (ft)	90		127				65
Base Capacity (vph)	196	2193	196	2004	766	516	924
Starvation Cap Reductn	0	0	0	0	0	0	0
Spillback Cap Reductn	0	0	0	0	0	0	0
Storage Cap Reductn	0	0	0	0	0	0	0
Reduced v/c Ratio	0.28	0.24	0.04	0.57	0.02	0.70	0.03

Intersection Summary

# 95th percentile volume exceeds capacity, queue may be longer.  
Queue shown is maximum after two cycles.

Queues  
1: Old Redwood Hwy & Shiloh Road



Lane Group	EBL	EBT	EBR	WBL	WBT	WBR	NBL	NBT	NBR	SBL	SBT	SBR
Lane Group Flow (vph)	317	188	586	44	198	38	611	559	44	51	538	265
v/c Ratio	0.82	0.32	0.53	0.37	0.71	0.12	0.80	0.68	0.06	0.41	1.06	0.50
Control Delay	67.3	36.5	5.5	70.8	68.6	0.8	57.5	37.5	2.6	71.2	103.3	24.2
Queue Delay	0.0	0.0	0.0	0.0	0.0	0.0	0.0	0.5	0.0	0.0	0.0	0.0
Total Delay	67.3	36.5	5.5	70.8	68.6	0.8	57.5	38.0	2.6	71.2	103.3	24.2
Queue Length 50th (ft)	264	127	54	38	167	0	256	393	0	43	~536	92
Queue Length 95th (ft)	#401	199	144	82	260	0	359	635	12	91	#851	200
Internal Link Dist (ft)		1709			528			668			695	
Turn Bay Length (ft)	425		200	200		50	430		98	190		220
Base Capacity (vph)	471	607	1132	523	598	562	854	826	724	220	507	525
Starvation Cap Reductn	0	0	0	0	0	0	0	58	0	0	0	0
Spillback Cap Reductn	0	0	0	0	0	0	0	0	0	0	0	0
Storage Cap Reductn	0	0	0	0	0	0	0	0	0	0	0	0
Reduced v/c Ratio	0.67	0.31	0.52	0.08	0.33	0.07	0.72	0.73	0.06	0.23	1.06	0.50

Intersection Summary

- ~ Volume exceeds capacity, queue is theoretically infinite.  
Queue shown is maximum after two cycles.
- # 95th percentile volume exceeds capacity, queue may be longer.  
Queue shown is maximum after two cycles.

Queues

2: Shiloh Road & Hembree Ln



Lane Group	EBL	EBT	WBL	WBT	NBL	NBT	SBL	SBT	SBR
Lane Group Flow (vph)	703	1014	110	1108	111	149	183	11	554
v/c Ratio	0.86	0.54	0.55	0.83	0.33	0.64	0.77	0.06	0.53
Control Delay	46.4	16.2	51.3	31.7	36.8	25.3	63.0	44.4	19.8
Queue Delay	0.0	0.0	0.0	0.0	0.0	0.0	0.0	0.0	0.0
Total Delay	46.4	16.2	51.3	31.7	36.8	25.3	63.0	44.4	19.8
Queue Length 50th (ft)	214	212	65	309	55	12	110	7	109
Queue Length 95th (ft)	#326	281	122	372	123	#85	#227	25	151
Internal Link Dist (ft)		222		1709		136		301	
Turn Bay Length (ft)			100				350		250
Base Capacity (vph)	864	1969	248	1568	367	242	252	208	1076
Starvation Cap Reductn	0	0	0	0	0	0	0	0	0
Spillback Cap Reductn	0	0	0	0	0	0	0	0	0
Storage Cap Reductn	0	0	0	0	0	0	0	0	0
Reduced v/c Ratio	0.81	0.51	0.44	0.71	0.30	0.62	0.73	0.05	0.51

Intersection Summary

# 95th percentile volume exceeds capacity, queue may be longer.  
 Queue shown is maximum after two cycles.



Queues  
3: US 101 NB Off-Ramp & Shiloh Road

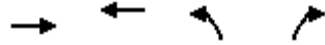

Lane Group	EBT	WBT	NBL	NBR
Lane Group Flow (vph)	843	947	771	870
v/c Ratio	0.72	0.81	0.90	0.63
Control Delay	17.2	20.9	27.8	10.2
Queue Delay	0.0	0.0	0.0	0.0
Total Delay	17.2	20.9	27.8	10.2
Queue Length 50th (ft)	96	113	161	76
Queue Length 95th (ft)	148	#201	#359	126
Internal Link Dist (ft)	106	291	689	
Turn Bay Length (ft)				340
Base Capacity (vph)	1211	1211	889	1430
Starvation Cap Reductn	0	0	0	0
Spillback Cap Reductn	0	0	0	0
Storage Cap Reductn	0	0	0	0
Reduced v/c Ratio	0.70	0.78	0.87	0.61

Intersection Summary

# 95th percentile volume exceeds capacity, queue may be longer.  
Queue shown is maximum after two cycles.

Queues  
6: Conde Lane & Shiloh Road

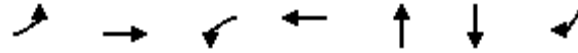

Lane Group	EBL	EBT	WBL	WBT	NBT	SBT	SBR
Lane Group Flow (vph)	77	707	9	1099	22	391	65
v/c Ratio	0.39	0.39	0.05	0.76	0.09	0.75	0.10
Control Delay	45.0	13.0	40.0	22.1	23.0	41.7	15.6
Queue Delay	0.0	0.0	0.0	0.0	0.0	0.0	0.0
Total Delay	45.0	13.0	40.0	22.1	23.0	41.7	15.6
Queue Length 50th (ft)	33	74	4	191	2	160	17
Queue Length 95th (ft)	#96	208	21	348	27	#437	49
Internal Link Dist (ft)		735		1001	338	442	
Turn Bay Length (ft)	90		127				65
Base Capacity (vph)	197	2178	197	1987	775	520	927
Starvation Cap Reductn	0	0	0	0	0	0	0
Spillback Cap Reductn	0	0	0	0	0	0	0
Storage Cap Reductn	0	0	0	0	0	0	0
Reduced v/c Ratio	0.39	0.32	0.05	0.55	0.03	0.75	0.07

Intersection Summary

# 95th percentile volume exceeds capacity, queue may be longer.  
Queue shown is maximum after two cycles.

Queues  
1: Old Redwood Hwy & Shiloh Road

GP 2040+Project Alternative C\_Mitigations  
Timing Plan: Saturday Midday Peak



Lane Group	EBL	EBT	EBR	WBL	WBT	WBR	NBL	NBT	NBR	SBL	SBT	SBR
Lane Group Flow (vph)	204	235	270	36	258	43	267	368	38	48	302	292
v/c Ratio	0.60	0.33	0.36	0.22	0.64	0.10	0.62	0.59	0.06	0.43	0.66	0.49
Control Delay	41.2	22.5	4.4	44.6	39.3	0.5	45.5	30.0	0.2	57.2	37.4	6.6
Queue Delay	0.0	0.0	0.0	0.0	0.0	0.0	0.0	0.0	0.0	0.0	0.0	0.0
Total Delay	41.2	22.5	4.4	44.6	39.3	0.5	45.5	30.0	0.2	57.2	37.4	6.6
Queue Length 50th (ft)	95	91	0	17	119	0	67	158	0	24	137	0
Queue Length 95th (ft)	206	183	51	55	235	0	#175	322	0	#93	278	64
Internal Link Dist (ft)		1709			528			668			695	
Turn Bay Length (ft)	425		200	200		50	430		98	190		220
Base Capacity (vph)	671	798	818	850	954	865	434	989	878	111	872	884
Starvation Cap Reductn	0	0	0	0	0	0	0	0	0	0	0	0
Spillback Cap Reductn	0	0	0	0	0	0	0	0	0	0	0	0
Storage Cap Reductn	0	0	0	0	0	0	0	0	0	0	0	0
Reduced v/c Ratio	0.30	0.29	0.33	0.04	0.27	0.05	0.62	0.37	0.04	0.43	0.35	0.33

Intersection Summary

# 95th percentile volume exceeds capacity, queue may be longer.  
Queue shown is maximum after two cycles.

Queues

GP 2040+Project Alternative C\_Mitigations

2: Shiloh Road & Hembree Ln

Timing Plan: Saturday Midday Peak



Lane Group	EBL	EBT	WBL	WBT	NBL	NBT	SBL	SBT	SBR
Lane Group Flow (vph)	918	569	110	677	111	149	236	11	856
v/c Ratio	0.86	0.34	0.52	0.70	0.29	0.65	0.83	0.05	0.60
Control Delay	38.4	13.8	44.4	25.7	31.5	25.8	61.2	40.7	11.5
Queue Delay	0.0	0.0	0.0	0.0	0.0	0.0	0.0	0.0	0.0
Total Delay	38.4	13.8	44.4	25.7	31.5	25.8	61.2	40.7	11.5
Queue Length 50th (ft)	215	91	51	134	42	10	114	5	80
Queue Length 95th (ft)	#447	133	120	186	121	#99	#307	25	174
Internal Link Dist (ft)		222		1709		136		301	
Turn Bay Length (ft)			100				350		250
Base Capacity (vph)	1062	2265	279	1722	408	229	283	216	1418
Starvation Cap Reductn	0	0	0	0	0	0	0	0	0
Spillback Cap Reductn	0	0	0	0	0	0	0	0	0
Storage Cap Reductn	0	0	0	0	0	0	0	0	0
Reduced v/c Ratio	0.86	0.25	0.39	0.39	0.27	0.65	0.83	0.05	0.60

Intersection Summary

# 95th percentile volume exceeds capacity, queue may be longer.  
 Queue shown is maximum after two cycles.

Queues  
3: US 101 NB Off-Ramp & Shiloh Road

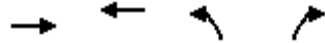

Lane Group	EBT	WBT	NBL	NBR
Lane Group Flow (vph)	631	1120	547	886
v/c Ratio	0.44	0.77	0.78	0.71
Control Delay	11.4	16.9	22.9	12.1
Queue Delay	0.0	0.0	0.0	0.0
Total Delay	11.4	16.9	22.9	12.1
Queue Length 50th (ft)	66	140	129	77
Queue Length 95th (ft)	101	202	#271	136
Internal Link Dist (ft)	106	291	689	
Turn Bay Length (ft)				340
Base Capacity (vph)	1576	1576	788	1381
Starvation Cap Reductn	0	0	0	0
Spillback Cap Reductn	0	0	0	0
Storage Cap Reductn	0	0	0	0
Reduced v/c Ratio	0.40	0.71	0.69	0.64

Intersection Summary

# 95th percentile volume exceeds capacity, queue may be longer.  
Queue shown is maximum after two cycles.

Queues  
6: Conde Lane & Shiloh Road

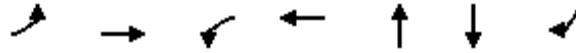

Lane Group	EBL	EBT	WBL	WBT	NBT	SBT	SBR
Lane Group Flow (vph)	45	552	14	979	18	373	53
v/c Ratio	0.22	0.35	0.07	0.72	0.06	0.63	0.09
Control Delay	42.1	14.7	41.5	22.5	0.4	33.8	17.4
Queue Delay	0.0	0.0	0.0	0.0	0.0	0.0	0.0
Total Delay	42.1	14.7	41.5	22.5	0.4	33.8	17.4
Queue Length 50th (ft)	19	63	6	179	0	142	15
Queue Length 95th (ft)	65	171	29	321	0	#319	38
Internal Link Dist (ft)		735		1001	338	442	
Turn Bay Length (ft)	90		127				65
Base Capacity (vph)	205	2211	202	2055	818	596	961
Starvation Cap Reductn	0	0	0	0	0	0	0
Spillback Cap Reductn	0	0	0	0	0	0	0
Storage Cap Reductn	0	0	0	0	0	0	0
Reduced v/c Ratio	0.22	0.25	0.07	0.48	0.02	0.63	0.06























Intersection Summary

# 95th percentile volume exceeds capacity, queue may be longer.  
Queue shown is maximum after two cycles.

Lanes, Volumes, Timings  
1: Old Redwood Hwy & Shiloh Road

General Plan 2040 Project Altern. C Conditions

Timing Plan: A.M. PEAK

												
Lane Group	EBL	EBT	EBR	WBL	WBT	WBR	NBL	NBT	NBR	SBL	SBT	SBR
Lane Configurations												
Traffic Volume (vph)	313	196	414	40	160	19	346	309	18	38	475	398
Future Volume (vph)	313	196	414	40	160	19	346	309	18	38	475	398
Ideal Flow (vphpl)	1900	1900	1900	1900	1900	1900	1900	1900	1900	1900	1900	1900
Storage Length (ft)	375		140	0		50	200		98	130		93
Storage Lanes	1		1	0		1	1		1	1		1
Taper Length (ft)	50			25			60			93		
Lane Util. Factor	1.00	1.00	1.00	1.00	1.00	1.00	1.00	1.00	1.00	1.00	1.00	1.00
Ped Bike Factor												0.98
Frt			0.850			0.850			0.850			0.850
Flt Protected	0.950				0.990		0.950			0.950		
Satd. Flow (prot)	1770	1863	1583	0	1844	1583	1770	1863	1583	1770	1863	1583
Flt Permitted	0.950				0.990		0.950			0.950		
Satd. Flow (perm)	1770	1863	1583	0	1844	1583	1770	1863	1583	1770	1863	1549
Right Turn on Red			Yes			Yes			Yes			Yes
Satd. Flow (RTOR)			480			105			77			142
Link Speed (mph)		40			40			45			40	
Link Distance (ft)		1789			608			748			775	
Travel Time (s)		30.5			10.4			11.3			13.2	
Confl. Bikes (#/hr)												1
Peak Hour Factor	0.81	0.81	0.81	0.89	0.89	0.89	0.93	0.93	0.93	0.85	0.85	0.85
Adj. Flow (vph)	386	242	511	45	180	21	372	332	19	45	559	468
Shared Lane Traffic (%)												
Lane Group Flow (vph)	386	242	511	0	225	21	372	332	19	45	559	468
Enter Blocked Intersection	No	No	No	No	No	No	No	No	No	No	No	No
Lane Alignment	Left	Left	Right	Left	Left	Right	Left	Left	Right	Left	Left	Right
Median Width(ft)		12			12			12			12	
Link Offset(ft)		0			0			0			0	
Crosswalk Width(ft)		16			16			16			16	
Two way Left Turn Lane												
Headway Factor	1.00	1.00	1.00	1.00	1.00	1.00	1.00	1.00	1.00	1.00	1.00	1.00
Turning Speed (mph)	15		9	15		9	15		9	15		9
Number of Detectors	1	2	1	1	2	1	1	2	1	1	2	1
Detector Template	Left	Thru	Right	Left	Thru	Right	Left	Thru	Right	Left	Thru	Right
Leading Detector (ft)	20	100	20	20	100	20	20	100	20	20	100	20
Trailing Detector (ft)	0	0	0	0	0	0	0	0	0	0	0	0
Detector 1 Position(ft)	0	0	0	0	0	0	0	0	0	0	0	0
Detector 1 Size(ft)	20	6	20	20	6	20	20	6	20	20	6	20
Detector 1 Type	Cl+Ex	Cl+Ex	Cl+Ex	Cl+Ex	Cl+Ex	Cl+Ex	Cl+Ex	Cl+Ex	Cl+Ex	Cl+Ex	Cl+Ex	Cl+Ex
Detector 1 Channel												
Detector 1 Extend (s)	0.0	0.0	0.0	0.0	0.0	0.0	0.0	0.0	0.0	0.0	0.0	0.0
Detector 1 Queue (s)	0.0	0.0	0.0	0.0	0.0	0.0	0.0	0.0	0.0	0.0	0.0	0.0
Detector 1 Delay (s)	0.0	0.0	0.0	0.0	0.0	0.0	0.0	0.0	0.0	0.0	0.0	0.0
Detector 2 Position(ft)		94			94			94			94	
Detector 2 Size(ft)		6			6			6			6	
Detector 2 Type		Cl+Ex			Cl+Ex			Cl+Ex			Cl+Ex	
Detector 2 Channel												
Detector 2 Extend (s)		0.0			0.0			0.0			0.0	
Turn Type	Split	NA	Perm	Split	NA	Perm	Prot	NA	Perm	Prot	NA	Perm

Lanes, Volumes, Timings  
1: Old Redwood Hwy & Shiloh Road

General Plan 2040 Project Altern. C Conditions

Timing Plan: A.M. PEAK

Lane Group	EBL	EBT	EBR	WBL	WBT	WBR	NBL	NBT	NBR	SBL	SBT	SBR
Protected Phases	2	2		6	6		3	8		7	4	
Permitted Phases			2			6			8			4
Detector Phase	2	2	2	6	6	6	3	8	8	7	4	4
Switch Phase												
Minimum Initial (s)	5.0	5.0	5.0	5.0	5.0	5.0	5.0	5.0	5.0	5.0	5.0	5.0
Minimum Split (s)	34.5	34.5	34.5	42.5	42.5	42.5	8.5	46.5	46.5	8.5	39.5	39.5
Total Split (s)	35.0	35.0	35.0	42.5	42.5	42.5	18.0	48.0	48.0	9.5	39.5	39.5
Total Split (%)	25.9%	25.9%	25.9%	31.5%	31.5%	31.5%	13.3%	35.6%	35.6%	7.0%	29.3%	29.3%
Maximum Green (s)	30.5	30.5	30.5	38.0	38.0	38.0	14.5	43.5	43.5	6.0	35.0	35.0
Yellow Time (s)	3.5	3.5	3.5	3.5	3.5	3.5	3.0	3.5	3.5	3.0	3.5	3.5
All-Red Time (s)	1.0	1.0	1.0	1.0	1.0	1.0	0.5	1.0	1.0	0.5	1.0	1.0
Lost Time Adjust (s)	0.0	0.0	0.0		0.0	0.0	0.0	0.0	0.0	0.0	0.0	0.0
Total Lost Time (s)	4.5	4.5	4.5		4.5	4.5	3.5	4.5	4.5	3.5	4.5	4.5
Lead/Lag	Lead	Lead	Lead	Lag	Lag	Lag	Lead	Lag	Lag	Lead	Lag	Lag
Lead-Lag Optimize?	Yes	Yes	Yes	Yes	Yes	Yes	Yes	Yes	Yes	Yes	Yes	Yes
Vehicle Extension (s)	3.0	3.0	3.0	3.0	3.0	3.0	3.0	3.0	3.0	3.0	3.0	3.0
Recall Mode	None	None	None	None	None	None	None	None	None	None	None	None
Walk Time (s)	7.0	7.0	7.0	7.0	7.0	7.0		7.0	7.0		7.0	7.0
Flash Don't Walk (s)	23.0	23.0	23.0	31.0	31.0	31.0		35.0	35.0		28.0	28.0
Pedestrian Calls (#/hr)	0	0	0	0	0	0		0	0		0	0
Act Effct Green (s)	30.1	30.1	30.1		19.3	19.3	14.5	45.6	45.6	5.9	35.1	35.1
Actuated g/C Ratio	0.26	0.26	0.26		0.17	0.17	0.13	0.39	0.39	0.05	0.30	0.30
v/c Ratio	0.84	0.50	0.67		0.73	0.06	1.68	0.45	0.03	0.50	0.99	0.83
Control Delay (s/veh)	59.1	41.7	9.5		60.4	0.3	358.0	30.3	0.1	74.5	77.7	40.2
Queue Delay	0.0	0.0	0.0		0.0	0.0	0.0	0.0	0.0	0.0	0.0	0.0
Total Delay (s/veh)	59.1	41.7	9.5		60.4	0.3	358.0	30.3	0.1	74.5	77.7	40.2
LOS	E	D	A		E	A	F	C	A	E	E	D
Approach Delay (s/veh)		33.1			55.3			198.2			61.2	
Approach LOS		C			E			F			E	

Intersection Summary

Area Type:	Other
Cycle Length:	135
Actuated Cycle Length:	116
Natural Cycle:	145
Control Type:	Actuated-Uncoordinated
Maximum v/c Ratio:	1.68
Intersection Signal Delay (s/veh):	81.8
Intersection LOS:	F
Intersection Capacity Utilization:	86.7%
ICU Level of Service:	E
Analysis Period (min):	15

Splits and Phases: 1: Old Redwood Hwy & Shiloh Road

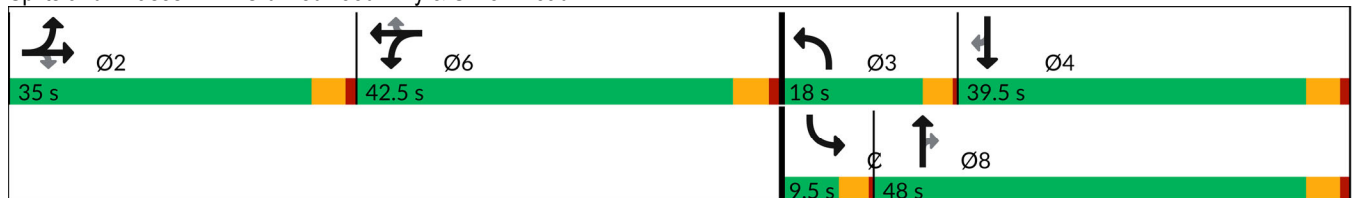

























Lanes, Volumes, Timings  
2: Shiloh Road & Hembree Ln

General Plan 2040 Project Altern. C Conditions

Timing Plan: A.M. PEAK

												
Lane Group	EBL	EBT	EBR	WBL	WBT	WBR	NBL	NBT	NBR	SBL	SBT	SBR
Lane Configurations	 				 						 	
Traffic Volume (vph)	311	778	103	49	765	90	49	11	16	129	18	570
Future Volume (vph)	311	778	103	49	765	90	49	11	16	129	18	570
Ideal Flow (vphpl)	1900	1900	1900	1900	1900	1900	1900	1900	1900	1900	1900	1900
Storage Length (ft)	0		0	100		130	0		0	0		0
Storage Lanes	2		0	1		1	1		0	0		1
Taper Length (ft)	25			50			25			25		
Lane Util. Factor	0.97	1.00	1.00	1.00	0.95	0.95	1.00	1.00	1.00	1.00	1.00	1.00
Frt		0.984			0.984			0.911				0.850
Flt Protected	0.950			0.950			0.950				0.958	
Satd. Flow (prot)	3433	1833	0	1770	3483	0	1770	1697	0	0	1785	1583
Flt Permitted	0.950			0.950			0.950				0.958	
Satd. Flow (perm)	3433	1833	0	1770	3483	0	1770	1697	0	0	1785	1583
Right Turn on Red			Yes			Yes			Yes			Yes
Satd. Flow (RTOR)		11			19			16				145
Link Speed (mph)		40			40			30				35
Link Distance (ft)		302			1789			216				381
Travel Time (s)		5.1			30.5			4.9				7.4
Peak Hour Factor	0.88	0.88	1.00	1.00	0.97	0.97	1.00	1.00	1.00	0.94	1.00	0.94
Adj. Flow (vph)	353	884	103	49	789	93	49	11	16	137	18	606
Shared Lane Traffic (%)												
Lane Group Flow (vph)	353	987	0	49	882	0	49	27	0	0	155	606
Enter Blocked Intersection	No	No	No	No	No	No	No	No	No	No	No	No
Lane Alignment	Left	Left	Right	Left	Left	Right	Left	Left	Right	Left	Left	Right
Median Width(ft)		24			24			12				12
Link Offset(ft)		0			0			0				0
Crosswalk Width(ft)		16			16			16				16
Two way Left Turn Lane												
Headway Factor	1.00	1.00	1.00	1.00	1.00	1.00	1.00	1.00	1.00	1.00	1.00	1.00
Turning Speed (mph)	15		60	60		9	60		60	15		9
Number of Detectors	1	2		1	2		1	2		1	2	1
Detector Template	Left	Thru		Left	Thru		Left	Thru		Left	Thru	Right
Leading Detector (ft)	20	100		20	100		20	100		20	100	20
Trailing Detector (ft)	0	0		0	0		0	0		0	0	0
Detector 1 Position(ft)	0	0		0	0		0	0		0	0	0
Detector 1 Size(ft)	20	6		20	6		20	6		20	6	20
Detector 1 Type	Cl+Ex	Cl+Ex		Cl+Ex	Cl+Ex		Cl+Ex	Cl+Ex		Cl+Ex	Cl+Ex	Cl+Ex
Detector 1 Channel												
Detector 1 Extend (s)	0.0	0.0		0.0	0.0		0.0	0.0		0.0	0.0	0.0
Detector 1 Queue (s)	0.0	0.0		0.0	0.0		0.0	0.0		0.0	0.0	0.0
Detector 1 Delay (s)	0.0	0.0		0.0	0.0		0.0	0.0		0.0	0.0	0.0
Detector 2 Position(ft)		94			94			94				94
Detector 2 Size(ft)		6			6			6				6
Detector 2 Type		Cl+Ex			Cl+Ex			Cl+Ex				Cl+Ex
Detector 2 Channel												
Detector 2 Extend (s)		0.0			0.0			0.0				0.0
Turn Type	Prot	NA		Prot	NA		Split	NA		Split	NA	pt+ov
Protected Phases	5	2		1	6		8	8		4	4	4
Permitted Phases												

Lanes, Volumes, Timings  
2: Shiloh Road & Hembree Ln

General Plan 2040 Project Altern. C Conditions

Timing Plan: A.M. PEAK

Lane Group	EBL	EBT	EBR	WBL	WBT	WBR	NBL	NBT	NBR	SBL	SBT	SBR
Detector Phase	5	2		1	6		8	8		4	4	4 5
Switch Phase												
Minimum Initial (s)	3.0	5.0		5.0	5.0		5.0	5.0		5.0	5.0	
Minimum Split (s)	7.5	9.5		9.5	43.5		9.5	9.5		9.5	9.5	
Total Split (s)	21.0	57.0		9.5	45.5		9.5	9.5		14.0	14.0	
Total Split (%)	23.3%	63.3%		10.6%	50.6%		10.6%	10.6%		15.6%	15.6%	
Maximum Green (s)	17.0	53.0		5.5	41.5		5.5	5.5		10.0	10.0	
Yellow Time (s)	3.0	3.0		3.0	3.0		3.0	3.0		3.0	3.0	
All-Red Time (s)	1.0	1.0		1.0	1.0		1.0	1.0		1.0	1.0	
Lost Time Adjust (s)	0.0	0.0		0.0	0.0		0.0	0.0		0.0	0.0	
Total Lost Time (s)	4.0	4.0		4.0	4.0		4.0	4.0		4.0	4.0	
Lead/Lag	Lead	Lag		Lead	Lag							
Lead-Lag Optimize?	Yes	Yes		Yes	Yes							
Vehicle Extension (s)	3.0	3.0		3.0	3.0		3.0	3.0		3.0	3.0	
Recall Mode	None	None		None	None		None	None		None	None	
Walk Time (s)					7.0							
Flash Don't Walk (s)					32.0							
Pedestrian Calls (#/hr)					1							
Act Effct Green (s)	17.7	48.1		5.7	31.3		5.7	5.7		10.4	29.3	
Actuated g/C Ratio	0.22	0.61		0.07	0.40		0.07	0.07		0.13	0.37	
v/c Ratio	0.46	0.88		0.38	0.63		0.38	0.20		0.66	0.90	
Control Delay (s/veh)	32.0	26.0		49.0	20.4		49.0	28.6		52.4	37.5	
Queue Delay	0.0	0.5		0.0	0.0		0.0	0.0		0.0	0.0	
Total Delay (s/veh)	32.0	26.4		49.0	20.4		49.0	28.6		52.4	37.5	
LOS	C	C		D	C		D	C		D	D	
Approach Delay (s/veh)		27.9			21.9			41.8			40.5	
Approach LOS		C			C			D			D	

Intersection Summary

Area Type:	Other
Cycle Length:	90
Actuated Cycle Length:	79
Natural Cycle:	100
Control Type:	Actuated-Uncoordinated
Maximum v/c Ratio:	0.90
Intersection Signal Delay (s/veh):	29.5
Intersection LOS:	C
Intersection Capacity Utilization:	76.1%
ICU Level of Service:	D
Analysis Period (min):	15

Splits and Phases: 2: Shiloh Road & Hembree Ln



Lanes, Volumes, Timings  
3: US 101 NB Off-Ramp & Shiloh Road

General Plan 2040 Project Altern. C Conditions  
Timing Plan: A.M. PEAK

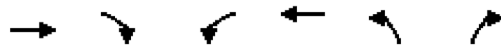

Lane Group	EBT	EBR	WBL	WBT	NBL	NBR
Lane Configurations	↑↑			↑	↘	↗↗
Traffic Volume (vph)	676	0	0	1037	813	517
Future Volume (vph)	676	0	0	1037	813	517
Ideal Flow (vphpl)	1900	1900	1900	1900	1900	1900
Storage Length (ft)		0	0		0	265
Storage Lanes		0	0		1	2
Taper Length (ft)			25		25	
Lane Util. Factor	0.95	1.00	1.00	1.00	1.00	0.88
Frt						0.850
Flt Protected					0.950	
Satd. Flow (prot)	3539	0	0	1863	1770	2787
Flt Permitted					0.950	
Satd. Flow (perm)	3539	0	0	1863	1770	2787
Right Turn on Red		Yes				Yes
Satd. Flow (RTOR)						226
Link Speed (mph)	40			40	30	
Link Distance (ft)	186			371	769	
Travel Time (s)	3.2			6.3	17.5	
Peak Hour Factor	0.91	0.91	0.90	0.90	0.76	0.76
Adj. Flow (vph)	743	0	0	1152	1070	680
Shared Lane Traffic (%)						
Lane Group Flow (vph)	743	0	0	1152	1070	680
Enter Blocked Intersection	No	No	No	No	No	No
Lane Alignment	Left	Right	Left	Left	Left	Right
Median Width(ft)	0			0	12	
Link Offset(ft)	0			0	0	
Crosswalk Width(ft)	16			16	16	
Two way Left Turn Lane						
Headway Factor	1.00	1.00	1.00	1.00	1.00	1.00
Turning Speed (mph)		9	15		15	9
Number of Detectors	2			2	1	1
Detector Template	Thru			Thru	Left	Right
Leading Detector (ft)	100			100	20	20
Trailing Detector (ft)	0			0	0	0
Detector 1 Position(ft)	0			0	0	0
Detector 1 Size(ft)	6			6	20	20
Detector 1 Type	Cl+Ex			Cl+Ex	Cl+Ex	Cl+Ex
Detector 1 Channel						
Detector 1 Extend (s)	0.0			0.0	0.0	0.0
Detector 1 Queue (s)	0.0			0.0	0.0	0.0
Detector 1 Delay (s)	0.0			0.0	0.0	0.0
Detector 2 Position(ft)	94			94		
Detector 2 Size(ft)	6			6		
Detector 2 Type	Cl+Ex			Cl+Ex		
Detector 2 Channel						
Detector 2 Extend (s)	0.0			0.0		
Turn Type	NA			NA	Prot	Perm
Protected Phases	2			6	8	
Permitted Phases						8

Lanes, Volumes, Timings  
 3: US 101 NB Off-Ramp & Shiloh Road

General Plan 2040 Project Altern. C Conditions

Timing Plan: A.M. PEAK



Lane Group	EBT	EBR	WBL	WBT	NBL	NBR
Detector Phase	2			6	8	8
Switch Phase						
Minimum Initial (s)	5.0			5.0	5.0	5.0
Minimum Split (s)	9.0			9.0	9.0	9.0
Total Split (s)	37.0			37.0	35.0	35.0
Total Split (%)	51.4%			51.4%	48.6%	48.6%
Maximum Green (s)	33.0			33.0	31.0	31.0
Yellow Time (s)	3.0			3.0	3.0	3.0
All-Red Time (s)	1.0			1.0	1.0	1.0
Lost Time Adjust (s)	0.0			0.0	0.0	0.0
Total Lost Time (s)	4.0			4.0	4.0	4.0
Lead/Lag						
Lead-Lag Optimize?						
Vehicle Extension (s)	3.0			3.0	3.0	3.0
Recall Mode	None			None	None	None
Act Effect Green (s)	33.0			33.0	31.0	31.0
Actuated g/C Ratio	0.46			0.46	0.43	0.43
v/c Ratio	0.46			1.35	1.40	0.51
Control Delay (s/veh)	14.5			187.7	212.4	11.2
Queue Delay	0.0			0.0	0.0	0.0
Total Delay (s/veh)	14.5			187.7	212.4	11.2
LOS	B			F	F	B
Approach Delay (s/veh)	14.5			187.7	134.2	
Approach LOS	B			F	F	

Intersection Summary

Area Type:	Other
Cycle Length:	72
Actuated Cycle Length:	72
Natural Cycle:	150
Control Type:	Actuated-Uncoordinated
Maximum v/c Ratio:	1.40
Intersection Signal Delay (s/veh):	126.7
Intersection LOS:	F
Intersection Capacity Utilization:	154.2%
ICU Level of Service:	H
Analysis Period (min):	15

Splits and Phases: 3: US 101 NB Off-Ramp & Shiloh Road

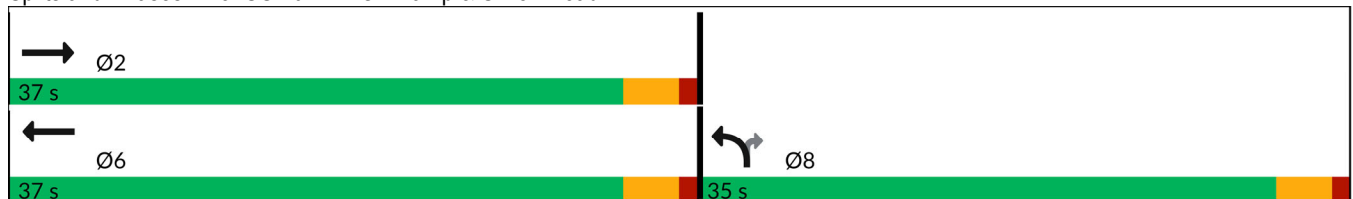

Lanes, Volumes, Timings  
4: Shiloh Road & US 101 SB Off-Ramp

General Plan 2040 Project Altern. C Conditions

Timing Plan: A.M. PEAK

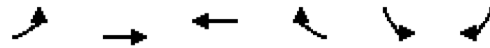

Lane Group	EBL	EBT	WBT	WBR	SBL	SBR
Lane Configurations		↑	↑		↘	↗
Traffic Volume (vph)	0	413	1146	0	263	184
Future Volume (vph)	0	413	1146	0	263	184
Ideal Flow (vphpl)	1900	1900	1900	1900	1900	1900
Storage Length (ft)	0			0	0	275
Storage Lanes	0			0	1	1
Taper Length (ft)	25				25	
Lane Util. Factor	1.00	1.00	1.00	1.00	1.00	1.00
Frt						0.850
Flt Protected					0.950	
Satd. Flow (prot)	0	1863	1863	0	1770	1583
Flt Permitted					0.950	
Satd. Flow (perm)	0	1863	1863	0	1770	1583
Right Turn on Red				Yes		Yes
Satd. Flow (RTOR)						108
Link Speed (mph)		40	40		30	
Link Distance (ft)		225	306		486	
Travel Time (s)		3.8	5.2		11.0	
Peak Hour Factor	0.93	0.93	0.91	0.91	0.92	0.92
Adj. Flow (vph)	0	444	1259	0	286	200
Shared Lane Traffic (%)						
Lane Group Flow (vph)	0	444	1259	0	286	200
Enter Blocked Intersection	No	No	No	No	No	No
Lane Alignment	Left	Left	Left	Right	Left	Right
Median Width(ft)		4	0		12	
Link Offset(ft)		0	0		0	
Crosswalk Width(ft)		16	16		16	
Two way Left Turn Lane						
Headway Factor	1.00	1.00	1.00	1.00	1.00	1.00
Turning Speed (mph)	15			9	15	9
Number of Detectors		2	2		1	1
Detector Template		Thru	Thru		Left	Right
Leading Detector (ft)		100	100		20	20
Trailing Detector (ft)		0	0		0	0
Detector 1 Position(ft)		0	0		0	0
Detector 1 Size(ft)		6	6		20	20
Detector 1 Type		Cl+Ex	Cl+Ex		Cl+Ex	Cl+Ex
Detector 1 Channel						
Detector 1 Extend (s)		0.0	0.0		0.0	0.0
Detector 1 Queue (s)		0.0	0.0		0.0	0.0
Detector 1 Delay (s)		0.0	0.0		0.0	0.0
Detector 2 Position(ft)		94	94			
Detector 2 Size(ft)		6	6			
Detector 2 Type		Cl+Ex	Cl+Ex			
Detector 2 Channel						
Detector 2 Extend (s)		0.0	0.0			
Turn Type		NA	NA		Perm	Perm
Protected Phases		2	6			
Permitted Phases					4	4

Lanes, Volumes, Timings  
4: Shiloh Road & US 101 SB Off-Ramp



Lane Group	EBL	EBT	WBT	WBR	SBL	SBR
Detector Phase		2	6		4	4
Switch Phase						
Minimum Initial (s)		5.0	5.0		5.0	5.0
Minimum Split (s)		9.0	38.0		9.0	9.0
Total Split (s)		69.0	69.0		21.0	21.0
Total Split (%)		76.7%	76.7%		23.3%	23.3%
Maximum Green (s)		65.0	65.0		17.0	17.0
Yellow Time (s)		3.0	3.0		3.0	3.0
All-Red Time (s)		1.0	1.0		1.0	1.0
Lost Time Adjust (s)		0.0	0.0		0.0	0.0
Total Lost Time (s)		4.0	4.0		4.0	4.0
Lead/Lag						
Lead-Lag Optimize?						
Vehicle Extension (s)		3.0	3.0		3.0	3.0
Recall Mode		None	None		None	None
Walk Time (s)			7.0			
Flash Don't Walk (s)			27.0			
Pedestrian Calls (#/hr)			0			
Act Effct Green (s)		60.2	60.2		16.1	16.1
Actuated g/C Ratio		0.71	0.71		0.19	0.19
v/c Ratio		0.33	0.95		0.85	0.51
Control Delay (s/veh)		5.4	27.6		58.4	21.0
Queue Delay		0.0	0.0		0.0	0.0
Total Delay (s/veh)		5.4	27.6		58.4	21.0
LOS		A	C		E	C
Approach Delay (s/veh)		5.4	27.6		43.0	
Approach LOS		A	C		D	

Intersection Summary	
Area Type:	Other
Cycle Length:	90
Actuated Cycle Length:	84.5
Natural Cycle:	90
Control Type:	Actuated-Uncoordinated
Maximum v/c Ratio:	0.95
Intersection Signal Delay (s/veh):	26.5
Intersection LOS:	C
Intersection Capacity Utilization:	138.0%
ICU Level of Service:	H
Analysis Period (min):	15

Splits and Phases: 4: Shiloh Road & US 101 SB Off-Ramp

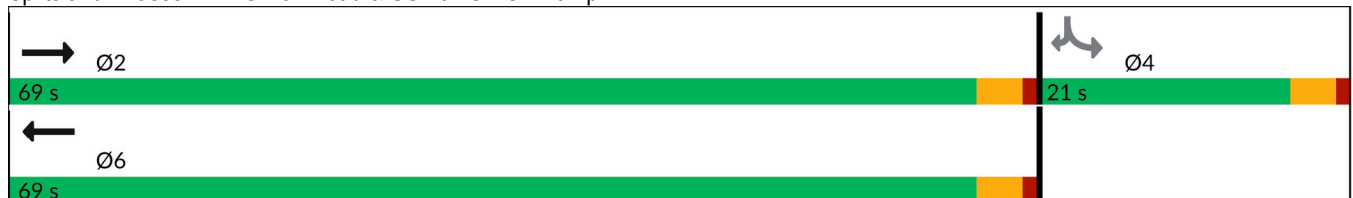

Lanes, Volumes, Timings  
5: Caletti Ave & Shiloh Road



















General Plan 2040 Project Altern. C Conditions

Timing Plan: A.M. PEAK

	→	↘	↙	←	↖	↗
Lane Group	EBT	EBR	WBL	WBT	NBL	NBR
Lane Configurations	↑↑		↘	↑	↘	↗
Traffic Volume (vph)	891	14	130	1200	17	122
Future Volume (vph)	891	14	130	1200	17	122
Ideal Flow (vphpl)	1900	1900	1900	1900	1900	1900
Storage Length (ft)		0	68		0	0
Storage Lanes		0	1		1	1
Taper Length (ft)			50		25	
Lane Util. Factor	0.95	0.95	1.00	1.00	1.00	1.00
Frt	0.998					0.850
Flt Protected			0.950		0.950	
Satd. Flow (prot)	3532	0	1770	1863	1770	1583
Flt Permitted			0.950		0.950	
Satd. Flow (perm)	3532	0	1770	1863	1770	1583
Link Speed (mph)	40			40	30	
Link Distance (ft)	1081			184	459	
Travel Time (s)	18.4			3.1	10.4	
Peak Hour Factor	0.96	0.96	0.87	0.87	0.84	0.84
Adj. Flow (vph)	928	15	149	1379	20	145
Shared Lane Traffic (%)						
Lane Group Flow (vph)	943	0	149	1379	20	145
Enter Blocked Intersection	No	No	No	No	No	No
Lane Alignment	Left	Right	Left	Left	Left	Right
Median Width(ft)	12			12	12	
Link Offset(ft)	0			0	0	
Crosswalk Width(ft)	16			16	16	
Two way Left Turn Lane						
Headway Factor	1.00	1.00	1.00	1.00	1.00	1.00
Turning Speed (mph)		9	15		15	9
Sign Control	Free			Free	Stop	
<b>Intersection Summary</b>						
Area Type:	Other					
Control Type:	Unsignalized					
Intersection Capacity Utilization	73.2%			ICU Level of Service D		
Analysis Period (min)	15					

Lanes, Volumes, Timings  
6: Conde Lane & Shiloh Road

General Plan 2040 Project Altern. C Conditions  
Timing Plan: A.M. PEAK

												
Lane Group	EBL	EBT	EBR	WBL	WBT	WBR	NBL	NBT	NBR	SBL	SBT	SBR
Lane Configurations												
Traffic Volume (vph)	55	526	3	8	847	298	2	1	9	363	0	27
Future Volume (vph)	55	526	3	8	847	298	2	1	9	363	0	27
Ideal Flow (vphpl)	1900	1900	1900	1900	1900	1900	1900	1900	1900	1900	1900	1900
Storage Length (ft)	90		0	127		0	0		0	0		40
Storage Lanes	1		0	1		0	0		0	0		1
Taper Length (ft)	70			40			25			25		
Lane Util. Factor	1.00	0.95	0.95	1.00	0.95	0.95	1.00	1.00	1.00	1.00	1.00	1.00
Frt		0.999			0.961			0.902				0.850
Flt Protected	0.950			0.950				0.991			0.950	
Satd. Flow (prot)	1770	3536	0	1770	3401	0	0	1665	0	0	1770	1583
Flt Permitted	0.950			0.950				0.991			0.950	
Satd. Flow (perm)	1770	3536	0	1770	3401	0	0	1665	0	0	1770	1583
Right Turn on Red			Yes			Yes			Yes			No
Satd. Flow (RTOR)		1			51			16				
Link Speed (mph)		40			40			30				35
Link Distance (ft)		815			1081			418				522
Travel Time (s)		13.9			18.4			9.5				10.2
Peak Hour Factor	0.95	0.95	0.95	0.85	0.85	0.85	0.57	0.57	0.57	0.86	0.86	0.86
Adj. Flow (vph)	58	554	3	9	996	351	4	2	16	422	0	31
Shared Lane Traffic (%)												
Lane Group Flow (vph)	58	557	0	9	1347	0	0	22	0	0	422	31
Enter Blocked Intersection	No	No	No	No	No	No	No	No	No	No	No	No
Lane Alignment	Left	Left	Right	Left	Left	Right	Left	Left	Right	Left	Left	Right
Median Width(ft)		12			12			0				0
Link Offset(ft)		0			0			0				0
Crosswalk Width(ft)		16			16			16				16
Two way Left Turn Lane												
Headway Factor	1.00	1.00	1.00	1.00	1.00	1.00	1.00	1.00	1.00	1.00	1.00	1.00
Turning Speed (mph)	15		9	15		9	15		9	15		9
Number of Detectors	1	2		1	2		1	2		1	1	1
Detector Template	Left	Thru		Left	Thru		Left	Thru		Left	Thru	Right
Leading Detector (ft)	20	100		20	100		20	100		20	30	20
Trailing Detector (ft)	0	0		0	0		0	0		0	0	0
Detector 1 Position(ft)	0	0		0	0		0	0		0	0	0
Detector 1 Size(ft)	20	6		20	6		20	6		20	30	20
Detector 1 Type	Cl+Ex	Cl+Ex		Cl+Ex	Cl+Ex		Cl+Ex	Cl+Ex		Cl+Ex	Cl+Ex	Cl+Ex
Detector 1 Channel												
Detector 1 Extend (s)	0.0	0.0		0.0	0.0		0.0	0.0		0.0	0.0	0.0
Detector 1 Queue (s)	0.0	0.0		0.0	0.0		0.0	0.0		0.0	0.0	0.0
Detector 1 Delay (s)	0.0	0.0		0.0	0.0		0.0	0.0		0.0	0.0	0.0
Detector 2 Position(ft)		94			94			94				
Detector 2 Size(ft)		6			6			6				
Detector 2 Type		Cl+Ex			Cl+Ex			Cl+Ex				
Detector 2 Channel												
Detector 2 Extend (s)		0.0			0.0			0.0				
Turn Type	Prot	NA		Prot	NA		Split	NA		Split	NA	custom
Protected Phases	5	2		1	6		7	7		4	4	
Permitted Phases												6



Lanes, Volumes, Timings  
6: Conde Lane & Shiloh Road

General Plan 2040 Project Altern. C Conditions

Timing Plan: A.M. PEAK

Lane Group	EBL	EBT	EBR	WBL	WBT	WBR	NBL	NBT	NBR	SBL	SBT	SBR
Detector Phase	5	2		1	6		7	7		4	4	6
Switch Phase												
Minimum Initial (s)	8.0	8.0		8.0	8.0		10.0	10.0		11.0	11.0	8.0
Minimum Split (s)	12.0	46.0		12.0	12.0		37.0	37.0		15.0	15.0	12.0
Total Split (s)	13.0	46.0		12.0	45.0		37.0	37.0		15.0	15.0	45.0
Total Split (%)	11.8%	41.8%		10.9%	40.9%		33.6%	33.6%		13.6%	13.6%	40.9%
Maximum Green (s)	9.0	42.0		8.0	41.0		33.0	33.0		11.0	11.0	41.0
Yellow Time (s)	3.0	3.0		3.0	3.0		3.0	3.0		3.0	3.0	3.0
All-Red Time (s)	1.0	1.0		1.0	1.0		1.0	1.0		1.0	1.0	1.0
Lost Time Adjust (s)	0.0	0.0		0.0	0.0		0.0	0.0		0.0	0.0	0.0
Total Lost Time (s)	4.0	4.0		4.0	4.0		4.0	4.0		4.0	4.0	4.0
Lead/Lag	Lead	Lag		Lead	Lag							Lag
Lead-Lag Optimize?	Yes	Yes		Yes	Yes							Yes
Vehicle Extension (s)	3.0	3.0		3.0	3.0		3.0	3.0		3.0	3.0	3.0
Recall Mode	None	None		None	None		None	None		None	None	None
Walk Time (s)		7.0					7.0	7.0				
Flash Don't Walk (s)		35.0					26.0	26.0				
Pedestrian Calls (#/hr)		0					0	0				
Act Effct Green (s)	8.6	46.9		8.2	42.1		10.3			11.3	42.1	
Actuated g/C Ratio	0.12	0.64		0.11	0.58		0.14			0.15	0.58	
v/c Ratio	0.28	0.25		0.05	0.68		0.09			1.55	0.03	
Control Delay (s/veh)	37.6	7.7		35.8	15.6		20.8			290.1	11.2	
Queue Delay	0.0	0.0		0.0	0.0		0.0			0.0	0.0	
Total Delay (s/veh)	37.6	7.7		35.8	15.6		20.8			290.1	11.2	
LOS	D	A		D	B		C			F	B	
Approach Delay (s/veh)		10.5			15.7		20.8			271.0		
Approach LOS		B			B		C			F		

Intersection Summary





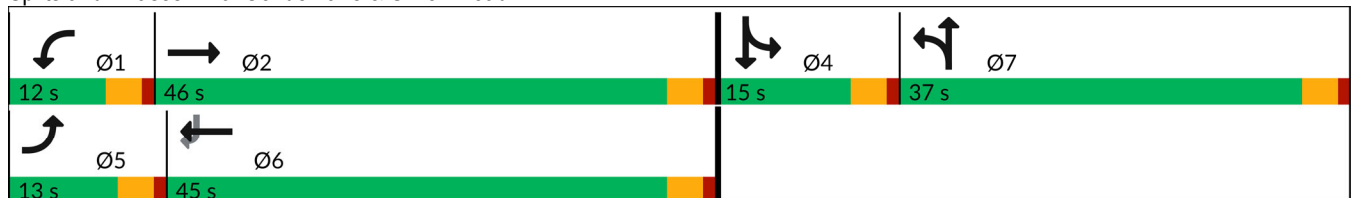











Area Type:	Other
Cycle Length:	110
Actuated Cycle Length:	73.2
Natural Cycle:	140
Control Type:	Actuated-Uncoordinated
Maximum v/c Ratio:	1.55
Intersection Signal Delay (s/veh):	61.7
Intersection LOS:	E
Intersection Capacity Utilization:	76.4%
ICU Level of Service:	D
Analysis Period (min):	15

Splits and Phases: 6: Conde Lane & Shiloh Road



Lanes, Volumes, Timings  
7: Entrance 1/Gridley Drive & Shiloh Road



















General Plan 2040 Project Altern. C Conditions  
Timing Plan: A.M. PEAK

												
Lane Group	EBL	EBT	EBR	WBL	WBT	WBR	NBL	NBT	NBR	SBL	SBT	SBR
Lane Configurations												
Traffic Volume (vph)	12	208	64	5	86	0	42	0	3	1	0	24
Future Volume (vph)	12	208	64	5	86	0	42	0	3	1	0	24
Ideal Flow (vphpl)	1900	1900	1900	1900	1900	1900	1900	1900	1900	1900	1900	1900
Lane Util. Factor	1.00	1.00	1.00	1.00	1.00	1.00	1.00	1.00	1.00	1.00	1.00	1.00
Ped Bike Factor												
Frt		0.970						0.850			0.869	
Flt Protected		0.998			0.997		0.950				0.999	
Satd. Flow (prot)	0	1803	0	0	1857	0	1770	1583	0	0	1617	0
Flt Permitted		0.998			0.997		0.950				0.999	
Satd. Flow (perm)	0	1803	0	0	1857	0	1770	1583	0	0	1617	0
Link Speed (mph)		40			40			30			30	
Link Distance (ft)		608			2146			248			715	
Travel Time (s)		10.4			36.6			5.6			16.3	
Confl. Bikes (#/hr)			1									
Peak Hour Factor	0.91	0.91	0.91	0.85	0.85	0.85	1.00	1.00	1.00	0.71	0.71	0.71
Adj. Flow (vph)	13	229	70	6	101	0	42	0	3	1	0	34
Shared Lane Traffic (%)												
Lane Group Flow (vph)	0	312	0	0	107	0	42	3	0	0	35	0
Enter Blocked Intersection	No	No	No	No	No	No	No	No	No	No	No	No
Lane Alignment	Left	Left	Right	Left	Left	Right	Left	Left	Right	Left	Left	Right
Median Width(ft)		0			0			12			12	
Link Offset(ft)		0			0			0			0	
Crosswalk Width(ft)		16			16			16			16	
Two way Left Turn Lane												
Headway Factor	1.00	1.00	1.00	1.00	1.00	1.00	1.00	1.00	1.00	1.00	1.00	1.00
Turning Speed (mph)	15		9	15		9	15		9	15		9
Sign Control		Free			Free			Stop			Stop	

Intersection Summary	
Area Type:	Other
Control Type:	Unsignalized
Intersection Capacity Utilization	34.4%
Analysis Period (min)	15
	ICU Level of Service A

Lanes, Volumes, Timings  
8: Old Redwood Hwy & Entrance 1











General Plan 2040 Project Altern. C Conditions  
Timing Plan: A.M. PEAK

												
Lane Group	EBL	EBT	EBR	WBL	WBT	WBR	NBL	NBT	NBR	SBL	SBT	SBR
Lane Configurations												
Traffic Volume (vph)	1	0	0	6	0	10	0	662	9	15	914	0
Future Volume (vph)	1	0	0	6	0	10	0	662	9	15	914	0
Ideal Flow (vphp)	1900	1900	1900	1900	1900	1900	1900	1900	1900	1900	1900	1900
Storage Length (ft)	0		0	0		0	0		0	50		0
Storage Lanes	0		0	1		0	0		0	1		0
Taper Length (ft)	25			25			25			25		
Lane Util. Factor	1.00	1.00	1.00	1.00	1.00	1.00	1.00	1.00	1.00	1.00	1.00	1.00
Ped Bike Factor												
Frt					0.850			0.998				
Flt Protected		0.950		0.950						0.950		
Satd. Flow (prot)	0	1770	0	1770	1583	0	0	1859	0	1770	1863	0
Flt Permitted		0.950		0.950						0.950		
Satd. Flow (perm)	0	1770	0	1770	1583	0	0	1859	0	1770	1863	0
Link Speed (mph)		30			30			45			45	
Link Distance (ft)		98			385			520			748	
Travel Time (s)		2.2			8.8			7.9			11.3	
Confl. Peds. (#/hr)									1	1		
Confl. Bikes (#/hr)									1			2
Peak Hour Factor	0.25	0.25	0.25	1.00	1.00	1.00	0.99	0.99	0.99	0.90	0.90	0.90
Adj. Flow (vph)	4	0	0	6	0	10	0	669	9	17	1016	0
Shared Lane Traffic (%)												
Lane Group Flow (vph)	0	4	0	6	10	0	0	678	0	17	1016	0
Enter Blocked Intersection	No	No	No	No	No	No	No	No	No	No	No	No
Lane Alignment	Left	Left	Right	Left	Left	Right	Left	Left	Right	Left	Left	Right
Median Width(ft)		12			12			12			12	
Link Offset(ft)		0			0			0			0	
Crosswalk Width(ft)		16			16			16			16	
Two way Left Turn Lane												
Headway Factor	1.00	1.00	1.00	1.00	1.00	1.00	1.00	1.00	1.00	1.00	1.00	1.00
Turning Speed (mph)	15		9	15		9	15		9	15		9
Sign Control		Stop			Stop			Free			Free	
<b>Intersection Summary</b>												
Area Type:	Other											
Control Type:	Unsignalized											
Intersection Capacity Utilization	58.1%					ICU Level of Service B						
Analysis Period (min)	15											

Lanes, Volumes, Timings  
9: Entrance 2 & Shiloh Road

General Plan 2040 Project Altern. C Conditions

Timing Plan: A.M. PEAK

						
Lane Group	EBT	EBR	WBL	WBT	NBL	NBR
Lane Configurations						
Traffic Volume (vph)	210	0	0	82	0	0
Future Volume (vph)	210	0	0	82	0	0
Ideal Flow (vphp)	1900	1900	1900	1900	1900	1900
Lane Util. Factor	1.00	1.00	1.00	1.00	1.00	1.00
<b>Fr</b>						
<b>Flt Protected</b>						
Satd. Flow (prot)	1863	0	0	1863	1863	1863
<b>Flt Permitted</b>						
Satd. Flow (perm)	1863	0	0	1863	1863	1863
Link Speed (mph)	40			40	30	
Link Distance (ft)	2146			134	402	
Travel Time (s)	36.6			2.3	9.1	
Peak Hour Factor	0.85	0.85	0.81	0.81	0.25	0.25
Adj. Flow (vph)	247	0	0	101	0	0
<b>Shared Lane Traffic (%)</b>						
Lane Group Flow (vph)	247	0	0	101	0	0
Enter Blocked Intersection	No	No	No	No	No	No
Lane Alignment	Left	Right	Left	Left	Left	Right
Median Width(ft)	0			0	12	
Link Offset(ft)	0			0	0	
Crosswalk Width(ft)	16			16	16	
<b>Two way Left Turn Lane</b>						
Headway Factor	1.00	1.00	1.00	1.00	1.00	1.00
Turning Speed (mph)		9	15		15	9
Sign Control	Free			Free	Stop	
<b>Intersection Summary</b>						
Area Type:	Other					
Control Type:	Unsignalized					
Intersection Capacity Utilization	14.4%			ICU Level of Service A		
Analysis Period (min)	15					

Lanes, Volumes, Timings

General Plan 2040 Project Altern. C Conditions

10: US 101 NB Off Ramp/Lakewood Drive & Old Redwood Highway

Timing Plan: A.M. PEAK



Lane Group	EBL	EBT	EBR	WBL	WBT	WBR	NBL	NBT	NBR	SBL	SBT	SBR
Lane Configurations												
Traffic Volume (vph)	264	619	0	0	656	156	224	255	92	255	0	679
Future Volume (vph)	264	619	0	0	656	156	224	255	92	255	0	679
Ideal Flow (vphpl)	1900	1900	1900	1900	1900	1900	1900	1900	1900	1900	1900	1900
Storage Length (ft)	155		0	0		0	270		150	120		0
Storage Lanes	1		0	0		0	1		1	1		1
Taper Length (ft)	50			25			165			75		
Lane Util. Factor	0.97	1.00	1.00	1.00	0.95	0.95	0.91	0.91	0.95	0.97	1.00	1.00
Ped Bike Factor	1.00				1.00			1.00		1.00		
Fr <sub>t</sub>					0.971			0.964				0.850
Fl <sub>t</sub> Protected	0.950						0.950	0.996		0.950		
Satd. Flow (prot)	3433	1863	0	0	3427	0	1610	3244	0	3433	0	1583
Fl <sub>t</sub> Permitted	0.950						0.950	0.996		0.950		
Satd. Flow (perm)	3431	1863	0	0	3427	0	1610	3244	0	3427	0	1583
Right Turn on Red			Yes			Yes			Yes			Yes
Satd. Flow (RTOR)					33			46				248
Link Speed (mph)		35			35			30				30
Link Distance (ft)		226			617			716				478
Travel Time (s)		4.4			12.0			16.3				10.9
Confl. Peds. (#/hr)	1		1	1		1			2	2		
Confl. Bikes (#/hr)			1			1						
Peak Hour Factor	0.85	0.85	0.85	0.83	0.83	0.83	0.90	0.90	0.90	0.89	0.89	0.89
Adj. Flow (vph)	311	728	0	0	790	188	249	283	102	287	0	763
Shared Lane Traffic (%)							15%					
Lane Group Flow (vph)	311	728	0	0	978	0	212	422	0	287	0	763
Enter Blocked Intersection	No	No	No	No	No	No	No	No	No	No	No	No
Lane Alignment	Left	Left	Right	Left	Left	Right	Left	Left	Right	Left	Left	Right
Median Width(ft)		24			24			24				24
Link Offset(ft)		0			0			0				0
Crosswalk Width(ft)		16			16			16				16
Two way Left Turn Lane												
Headway Factor	1.00	1.00	1.00	1.00	1.00	1.00	1.00	1.00	1.00	1.00	1.00	1.00
Turning Speed (mph)	15		9	15		9	15		9	15		9
Number of Detectors	1	2			2		1	2		1		1
Detector Template	Left	Thru			Thru		Left	Thru		Left		Right
Leading Detector (ft)	20	100			100		20	100		20		20
Trailing Detector (ft)	0	0			0		0	0		0		0
Detector 1 Position(ft)	0	0			0		0	0		0		0
Detector 1 Size(ft)	20	6			6		20	6		20		20
Detector 1 Type	Cl+Ex	Cl+Ex			Cl+Ex		Cl+Ex	Cl+Ex		Cl+Ex		Cl+Ex
Detector 1 Channel												
Detector 1 Extend (s)	0.0	0.0			0.0		0.0	0.0		0.0		0.0
Detector 1 Queue (s)	0.0	0.0			0.0		0.0	0.0		0.0		0.0
Detector 1 Delay (s)	0.0	0.0			0.0		0.0	0.0		0.0		0.0
Detector 2 Position(ft)		94			94			94				
Detector 2 Size(ft)		6			6			6				
Detector 2 Type		Cl+Ex			Cl+Ex			Cl+Ex				
Detector 2 Channel												
Detector 2 Extend (s)		0.0			0.0			0.0				

Lanes, Volumes, Timings

General Plan 2040 Project Altern. C Conditions

10: US 101 NB Off Ramp/Lakewood Drive & Old Redwood Highway

Timing Plan: A.M. PEAK



Lane Group	EBL	EBT	EBR	WBL	WBT	WBR	NBL	NBT	NBR	SBL	SBT	SBR
Turn Type	Prot	NA			NA		Split	NA		Prot		pm+ov
Protected Phases	5	2			6		8	8		7		5
Permitted Phases												5 8
Detector Phase	5	2			6		8	8		7		5
Switch Phase												
Minimum Initial (s)	7.0	10.0			10.0		10.0	10.0		7.0		7.0
Minimum Split (s)	11.0	32.1			32.1		33.7	33.7		11.0		11.0
Total Split (s)	13.0	45.3			32.3		33.7	33.7		11.0		13.0
Total Split (%)	14.4%	50.3%			35.9%		37.4%	37.4%		12.2%		14.4%
Maximum Green (s)	9.0	40.2			27.2		29.0	29.0		7.0		9.0
Yellow Time (s)	3.0	4.1			4.1		3.7	3.7		3.0		3.0
All-Red Time (s)	1.0	1.0			1.0		1.0	1.0		1.0		1.0
Lost Time Adjust (s)	0.0	0.0			0.0		0.0	0.0		0.0		0.0
Total Lost Time (s)	4.0	5.1			5.1		4.7	4.7		4.0		4.0
Lead/Lag	Lead				Lag		Lag	Lag		Lead		Lead
Lead-Lag Optimize?	Yes				Yes		Yes	Yes		Yes		Yes
Vehicle Extension (s)	3.0	3.0			3.0		3.0	3.0		3.0		3.0
Recall Mode	None	Max			Max		None	None		None		None
Walk Time (s)		7.0			7.0		7.0	7.0				
Flash Don't Walk (s)		20.0			17.0		22.0	22.0				
Pedestrian Calls (#/hr)		0			0		0	0				
Act Effct Green (s)	9.0	40.4			27.3		17.0	17.0		7.0		30.8
Actuated g/C Ratio	0.11	0.52			0.35		0.22	0.22		0.09		0.39
v/c Ratio	0.79	0.76			0.80		0.61	0.57		0.93		0.99
Control Delay (s/veh)	50.6	23.1			29.7		35.0	27.0		75.7		47.0
Queue Delay	0.0	0.0			0.0		0.0	0.0		0.0		0.0
Total Delay (s/veh)	50.6	23.1			29.7		35.0	27.0		75.7		47.0
LOS	D	C			C		D	C		E		D
Approach Delay (s/veh)		31.3			29.7			29.7				54.8
Approach LOS		C			C			C				D

Intersection Summary

Area Type: Other  
 Cycle Length: 90  
 Actuated Cycle Length: 78.3  
 Natural Cycle: 90  
 Control Type: Actuated-Uncoordinated  
 Maximum v/c Ratio: 0.99  
 Intersection Signal Delay (s/veh): 37.3  
 Intersection LOS: D  
 Intersection Capacity Utilization 88.6%  
 ICU Level of Service E  
 Analysis Period (min) 15

Splits and Phases: 10: US 101 NB Off Ramp/Lakewood Drive & Old Redwood Highway

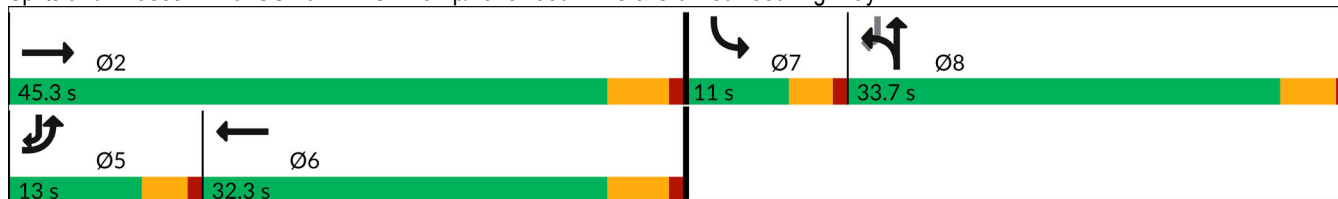

Lanes, Volumes, Timings  
 11: Old Redwood Highway & US 101 NB On Ramp

General Plan 2040 Project Altern. C Conditions

Timing Plan: A.M. PEAK

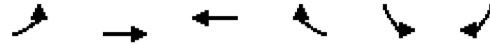

Lane Group	EBL	EBT	WBT	WBR	SBL	SBR
Lane Configurations						
Traffic Volume (vph)	0	883	1301	252	0	0
Future Volume (vph)	0	883	1301	252	0	0
Ideal Flow (vphpl)	1900	1900	1900	1900	1900	1900
Storage Length (ft)	245			0	0	0
Storage Lanes	1			0	0	0
Taper Length (ft)	50				25	
Lane Util. Factor	1.00	0.95	0.95	0.95	1.00	1.00
Ped Bike Factor						
Frt			0.976			
Flt Protected						
Satd. Flow (prot)	1863	3539	3454	0	0	0
Flt Permitted						
Satd. Flow (perm)	1863	3539	3454	0	0	0
Link Speed (mph)		35	35		30	
Link Distance (ft)		531	226		299	
Travel Time (s)		10.3	4.4		6.8	
Confl. Peds. (#/hr)	9					
Confl. Bikes (#/hr)				1		
Peak Hour Factor	0.81	0.81	0.89	0.89	0.25	0.25
Adj. Flow (vph)	0	1090	1462	283	0	0
Shared Lane Traffic (%)						
Lane Group Flow (vph)	0	1090	1745	0	0	0
Enter Blocked Intersection	No	No	No	No	No	No
Lane Alignment	Left	Left	Left	Right	Left	Right
Median Width(ft)		12	12		0	
Link Offset(ft)		0	0		0	
Crosswalk Width(ft)		16	16		16	
Two way Left Turn Lane						
Headway Factor	1.00	1.00	1.00	1.00	1.00	1.00
Turning Speed (mph)	15			9	15	9
Sign Control		Free	Free		Free	

Intersection Summary

Area Type:	Other
Control Type:	Unsignalized
Intersection Capacity Utilization	102.2%
Analysis Period (min)	15
	ICU Level of Service G

Lanes, Volumes, Timings

General Plan 2040 Project Altern. C Conditions

12: US 101 SB On Ramp/US 101 SB Off Ramp & Old Redwood Highway

Timing Plan: A.M. PEAK



Lane Group	EBL	EBT	EBR	WBL	WBT	WBR	NBL	NBT	NBR	SBL	SBT	SBR
Lane Configurations		↑↑	↗	↘	↑↑					↘	↕	
Traffic Volume (vph)	0	699	814	559	742	0	0	0	0	166	0	144
Future Volume (vph)	0	699	814	559	742	0	0	0	0	166	0	144
Ideal Flow (vphpl)	1900	1900	1900	1900	1900	1900	1900	1900	1900	1900	1900	1900
Storage Length (ft)	0		0	250		0	0		0	420		0
Storage Lanes	0		1	0		0	0		0	1		0
Taper Length (ft)	25			165			25			75		
Lane Util. Factor	1.00	0.95	1.00	1.00	0.95	1.00	1.00	1.00	1.00	0.95	0.95	1.00
Ped Bike Factor			0.98	1.00								
Frt			0.850								0.866	
Flt Protected				0.950						0.950	0.995	
Satd. Flow (prot)	0	3539	1583	1770	3539	0	0	0	0	1681	1525	0
Flt Permitted				0.950						0.950	0.995	
Satd. Flow (perm)	0	3539	1558	1768	3539	0	0	0	0	1681	1525	0
Right Turn on Red			Yes			Yes			Yes			Yes
Satd. Flow (RTOR)			361								178	
Link Speed (mph)		35			35			30			30	
Link Distance (ft)		423			531			621			831	
Travel Time (s)		8.2			10.3			14.1			18.9	
Confl. Peds. (#/hr)	10		3	3		10						
Confl. Bikes (#/hr)			2									
Peak Hour Factor	0.92	0.92	0.92	0.89	0.89	0.89	0.25	0.25	0.25	0.81	0.81	0.81
Adj. Flow (vph)	0	760	885	628	834	0	0	0	0	205	0	178
Shared Lane Traffic (%)										10%		
Lane Group Flow (vph)	0	760	885	628	834	0	0	0	0	184	199	0
Enter Blocked Intersection	No	No	No	No	No	No	No	No	No	No	No	No
Lane Alignment	Left	Left	Right	Left	Left	Right	Left	Left	Right	Left	Left	Right
Median Width(ft)		24			24			12			12	
Link Offset(ft)		0			0			0			0	
Crosswalk Width(ft)		16			16			16			16	
Two way Left Turn Lane												
Headway Factor	1.00	1.00	1.00	1.00	1.00	1.00	1.00	1.00	1.00	1.00	1.00	1.00
Turning Speed (mph)	15		9	15		9	15		9	15		9
Number of Detectors		2	1	1	2					1	2	
Detector Template		Thru	Right	Left	Thru					Left	Thru	
Leading Detector (ft)		100	20	20	100					20	100	
Trailing Detector (ft)		0	0	0	0					0	0	
Detector 1 Position(ft)		0	0	0	0					0	0	
Detector 1 Size(ft)		6	20	20	6					20	6	
Detector 1 Type		Cl+Ex	Cl+Ex	Cl+Ex	Cl+Ex					Cl+Ex	Cl+Ex	
Detector 1 Channel												
Detector 1 Extend (s)		0.0	0.0	0.0	0.0					0.0	0.0	
Detector 1 Queue (s)		0.0	0.0	0.0	0.0					0.0	0.0	
Detector 1 Delay (s)		0.0	0.0	0.0	0.0					0.0	0.0	
Detector 2 Position(ft)		94			94							94
Detector 2 Size(ft)		6			6							6
Detector 2 Type		Cl+Ex			Cl+Ex							Cl+Ex
Detector 2 Channel												
Detector 2 Extend (s)		0.0			0.0							0.0



Lanes, Volumes, Timings

General Plan 2040 Project Altern. C Conditions

12: US 101 SB On Ramp/US 101 SB Off Ramp & Old Redwood Highway

Timing Plan: A.M. PEAK



Lane Group	EBL	EBT	EBR	WBL	WBT	WBR	NBL	NBT	NBR	SBL	SBT	SBR
Turn Type		NA	Perm	Prot	NA					Perm	NA	
Protected Phases		6		5	2						8	
Permitted Phases			6							8		
Detector Phase		6	6	5	2					8	8	
Switch Phase												
Minimum Initial (s)		10.0	10.0	7.0	10.0					10.0	10.0	
Minimum Split (s)		32.1	32.1	11.0	38.1					14.7	14.7	
Total Split (s)		32.3	32.3	33.0	65.3					14.7	14.7	
Total Split (%)		40.4%	40.4%	41.3%	81.6%					18.4%	18.4%	
Maximum Green (s)		27.2	27.2	29.0	60.2					10.0	10.0	
Yellow Time (s)		4.1	4.1	3.0	4.1					3.7	3.7	
All-Red Time (s)		1.0	1.0	1.0	1.0					1.0	1.0	
Lost Time Adjust (s)		0.0	0.0	0.0	0.0					0.0	0.0	
Total Lost Time (s)		5.1	5.1	4.0	5.1					4.7	4.7	
Lead/Lag		Lag	Lag	Lead								
Lead-Lag Optimize?		Yes	Yes	Yes								
Vehicle Extension (s)		3.0	3.0	3.0	3.0					3.0	3.0	
Recall Mode		Max	Max	None	Max					None	None	
Walk Time (s)		7.0	7.0		7.0							
Flash Don't Walk (s)		20.0	20.0		25.0							
Pedestrian Calls (#/hr)		0	0		0							
Act Effct Green (s)		27.2	27.2	29.0	60.2					10.0	10.0	
Actuated g/C Ratio		0.34	0.34	0.36	0.75					0.13	0.13	
v/c Ratio		0.63	1.15	0.98	0.31					0.88	0.58	
Control Delay (s/veh)		25.1	101.9	58.5	3.6					74.1	14.6	
Queue Delay		0.0	0.0	0.0	0.0					0.0	0.0	
Total Delay (s/veh)		25.1	101.9	58.5	3.6					74.1	14.6	
LOS		C	F	E	A					E	B	
Approach Delay (s/veh)		66.4			27.1						43.2	
Approach LOS		E			C						D	

Intersection Summary

Area Type: Other

Cycle Length: 80

Actuated Cycle Length: 80

Natural Cycle: 110

Control Type: Actuated-Uncoordinated

Maximum v/c Ratio: 1.15

Intersection Signal Delay (s/veh): 47.4

Intersection LOS: D

Intersection Capacity Utilization 102.2%

ICU Level of Service G

Analysis Period (min) 15



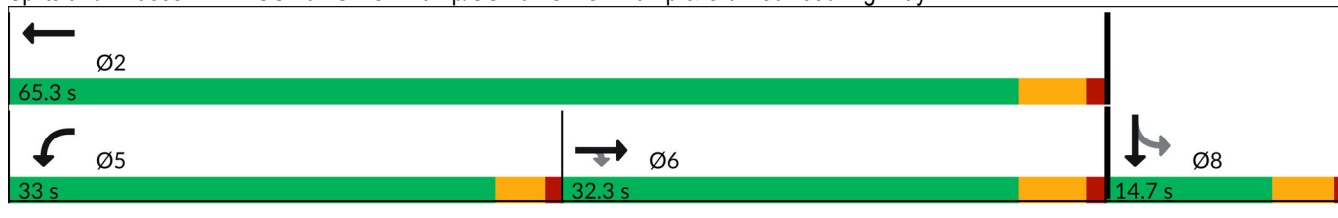



















Splits and Phases: 12: US 101 SB On Ramp/US 101 SB Off Ramp & Old Redwood Highway



Lanes, Volumes, Timings  
1: Old Redwood Hwy & Shiloh Road

General Plan 2040 Project Altern. C Conditions

Timing Plan: P.M. Peak

												
Lane Group	EBL	EBT	EBR	WBL	WBT	WBR	NBL	NBT	NBR	SBL	SBT	SBR
Lane Configurations												
Traffic Volume (vph)	317	188	586	44	198	38	611	559	44	51	538	265
Future Volume (vph)	317	188	586	44	198	38	611	559	44	51	538	265
Ideal Flow (vphpl)	1900	1900	1900	1900	1900	1900	1900	1900	1900	1900	1900	1900
Storage Length (ft)	375		140	0		50	200		98	130		93
Storage Lanes	1		1	0		1	1		1	1		1
Taper Length (ft)	50			25			60			93		
Lane Util. Factor	1.00	1.00	1.00	1.00	1.00	1.00	1.00	1.00	1.00	1.00	1.00	1.00
Ped Bike Factor	1.00					0.98	1.00		0.98			0.97
Frt			0.850			0.850			0.850			0.850
Flt Protected	0.950				0.991		0.950			0.950		
Satd. Flow (prot)	1770	1863	1583	0	1846	1583	1770	1863	1583	1770	1863	1583
Flt Permitted	0.950				0.991		0.950			0.950		
Satd. Flow (perm)	1767	1863	1583	0	1846	1549	1768	1863	1546	1770	1863	1542
Right Turn on Red			Yes			Yes			Yes			Yes
Satd. Flow (RTOR)			563			105			77			105
Link Speed (mph)		40			40			45				40
Link Distance (ft)		1789			608			748				775
Travel Time (s)		30.5			10.4			11.3				13.2
Confl. Peds. (#/hr)	1						1	1				1
Confl. Bikes (#/hr)									3			3
Peak Hour Factor	0.97	0.97	0.97	0.91	0.91	0.91	0.93	0.93	0.93	0.93	0.93	0.93
Adj. Flow (vph)	327	194	604	48	218	42	657	601	47	55	578	285
Shared Lane Traffic (%)												
Lane Group Flow (vph)	327	194	604	0	266	42	657	601	47	55	578	285
Enter Blocked Intersection	No	No	No	No	No	No	No	No	No	No	No	No
Lane Alignment	Left	Left	Right	Left	Left	Right	Left	Left	Right	Left	Left	Right
Median Width(ft)		12			12			12				12
Link Offset(ft)		0			0			0				0
Crosswalk Width(ft)		16			16			16				16
Two way Left Turn Lane												
Headway Factor	1.00	1.00	1.00	1.00	1.00	1.00	1.00	1.00	1.00	1.00	1.00	1.00
Turning Speed (mph)	15		9	15		9	15		9	15		9
Number of Detectors	1	2	1	1	2	1	1	2	1	1	2	1
Detector Template	Left	Thru	Right	Left	Thru	Right	Left	Thru	Right	Left	Thru	Right
Leading Detector (ft)	20	100	20	20	100	20	20	100	20	20	100	20
Trailing Detector (ft)	0	0	0	0	0	0	0	0	0	0	0	0
Detector 1 Position(ft)	0	0	0	0	0	0	0	0	0	0	0	0
Detector 1 Size(ft)	20	6	20	20	6	20	20	6	20	20	6	20
Detector 1 Type	Cl+Ex	Cl+Ex	Cl+Ex	Cl+Ex	Cl+Ex	Cl+Ex	Cl+Ex	Cl+Ex	Cl+Ex	Cl+Ex	Cl+Ex	Cl+Ex
Detector 1 Channel												
Detector 1 Extend (s)	0.0	0.0	0.0	0.0	0.0	0.0	0.0	0.0	0.0	0.0	0.0	0.0
Detector 1 Queue (s)	0.0	0.0	0.0	0.0	0.0	0.0	0.0	0.0	0.0	0.0	0.0	0.0
Detector 1 Delay (s)	0.0	0.0	0.0	0.0	0.0	0.0	0.0	0.0	0.0	0.0	0.0	0.0
Detector 2 Position(ft)		94			94			94				94
Detector 2 Size(ft)		6			6			6				6
Detector 2 Type		Cl+Ex			Cl+Ex			Cl+Ex				Cl+Ex
Detector 2 Channel												
Detector 2 Extend (s)		0.0			0.0			0.0				0.0

Lanes, Volumes, Timings  
1: Old Redwood Hwy & Shiloh Road

General Plan 2040 Project Altern. C Conditions

Timing Plan: P.M. Peak

Lane Group	EBL	EBT	EBR	WBL	WBT	WBR	NBL	NBT	NBR	SBL	SBT	SBR
Turn Type	Split	NA	Perm	Split	NA	Perm	Prot	NA	Perm	Prot	NA	Perm
Protected Phases	2	2		6	6		3	8		7	4	
Permitted Phases			2			6			8			4
Detector Phase	2	2	2	6	6	6	3	8	8	7	4	4
Switch Phase												
Minimum Initial (s)	5.0	5.0	5.0	5.0	5.0	5.0	5.0	5.0	5.0	5.0	5.0	5.0
Minimum Split (s)	34.5	34.5	34.5	42.5	42.5	42.5	8.5	46.5	46.5	8.5	39.5	39.5
Total Split (s)	35.0	35.0	35.0	42.5	42.5	42.5	18.0	48.0	48.0	9.5	39.5	39.5
Total Split (%)	25.9%	25.9%	25.9%	31.5%	31.5%	31.5%	13.3%	35.6%	35.6%	7.0%	29.3%	29.3%
Maximum Green (s)	30.5	30.5	30.5	38.0	38.0	38.0	14.5	43.5	43.5	6.0	35.0	35.0
Yellow Time (s)	3.5	3.5	3.5	3.5	3.5	3.5	3.0	3.5	3.5	3.0	3.5	3.5
All-Red Time (s)	1.0	1.0	1.0	1.0	1.0	1.0	0.5	1.0	1.0	0.5	1.0	1.0
Lost Time Adjust (s)	0.0	0.0	0.0		0.0	0.0	0.0	0.0	0.0	0.0	0.0	0.0
Total Lost Time (s)	4.5	4.5	4.5		4.5	4.5	3.5	4.5	4.5	3.5	4.5	4.5
Lead/Lag	Lead	Lead	Lead	Lag	Lag	Lag	Lead	Lag	Lag	Lead	Lag	Lag
Lead-Lag Optimize?	Yes	Yes	Yes	Yes	Yes	Yes	Yes	Yes	Yes	Yes	Yes	Yes
Vehicle Extension (s)	3.0	3.0	3.0	3.0	3.0	3.0	3.0	3.0	3.0	3.0	3.0	3.0
Recall Mode	None	None	None	None	None	None	None	None	None	None	None	None
Walk Time (s)	7.0	7.0	7.0	7.0	7.0	7.0		7.0	7.0		7.0	7.0
Flash Don't Walk (s)	23.0	23.0	23.0	31.0	31.0	31.0		35.0	35.0		28.0	28.0
Pedestrian Calls (#/hr)	0	0	0	0	0	0		0	0		0	0
Act Effct Green (s)	27.3	27.3	27.3		21.9	21.9	14.6	46.0	46.0	6.0	35.3	35.3
Actuated g/C Ratio	0.23	0.23	0.23		0.19	0.19	0.13	0.40	0.40	0.05	0.30	0.30
v/c Ratio	0.79	0.44	0.75		0.76	0.11	2.96	0.82	0.07	0.60	1.02	0.53
Control Delay (s/veh)	57.0	42.4	11.6		59.8	0.6	913.0	44.5	2.3	83.3	85.2	26.3
Queue Delay	0.0	0.0	0.0		0.0	0.0	0.0	0.0	0.0	0.0	0.0	0.0
Total Delay (s/veh)	57.0	42.4	11.6		59.8	0.6	913.0	44.5	2.3	83.3	85.2	26.3
LOS	E	D	B		E	A	F	D	A	F	F	C
Approach Delay (s/veh)		30.1			51.7			480.2			66.8	
Approach LOS		C			D			F			E	

Intersection Summary

Area Type: Other  
 Cycle Length: 135  
 Actuated Cycle Length: 116.2  
 Natural Cycle: 145  
 Control Type: Actuated-Uncoordinated  
 Maximum v/c Ratio: 2.96  
 Intersection Signal Delay (s/veh): 201.8  
 Intersection LOS: F  
 Intersection Capacity Utilization 107.8%  
 ICU Level of Service G  
 Analysis Period (min) 15



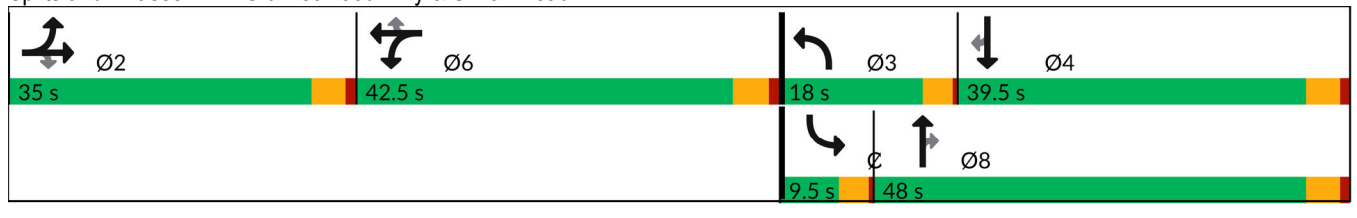

















Splits and Phases: 1: Old Redwood Hwy & Shiloh Road



Lanes, Volumes, Timings  
2: Shiloh Road & Hembree Ln

General Plan 2040 Project Altern. C Conditions

Timing Plan: P.M. Peak

												
Lane Group	EBL	EBT	EBR	WBL	WBT	WBR	NBL	NBT	NBR	SBL	SBT	SBR
Lane Configurations												
Traffic Volume (vph)	661	888	69	110	846	118	111	21	128	174	11	526
Future Volume (vph)	661	888	69	110	846	118	111	21	128	174	11	526
Ideal Flow (vphpl)	1900	1900	1900	1900	1900	1900	1900	1900	1900	1900	1900	1900
Storage Length (ft)	0		0	100		130	0		0	0		0
Storage Lanes	2		0	1		1	1		0	0		1
Taper Length (ft)	25			50			25			25		
Lane Util. Factor	0.97	1.00	1.00	1.00	0.95	0.95	1.00	1.00	1.00	1.00	1.00	1.00
Ped Bike Factor	1.00				1.00							
Frt		0.990			0.982			0.871				0.850
Flt Protected	0.950			0.950			0.950				0.955	
Satd. Flow (prot)	3433	1844	0	1770	3470	0	1770	1622	0	0	1779	1583
Flt Permitted	0.950			0.950			0.950				0.955	
Satd. Flow (perm)	3431	1844	0	1770	3470	0	1770	1622	0	0	1779	1583
Right Turn on Red			Yes			Yes			Yes			Yes
Satd. Flow (RTOR)		7			23			128				68
Link Speed (mph)		40			40			30				35
Link Distance (ft)		302			1789			216				381
Travel Time (s)		5.1			30.5			4.9				7.4
Confl. Peds. (#/hr)	2						2					
Peak Hour Factor	0.94	0.94	1.00	1.00	0.87	0.87	1.00	1.00	1.00	0.95	1.00	0.95
Adj. Flow (vph)	703	945	69	110	972	136	111	21	128	183	11	554
Shared Lane Traffic (%)												
Lane Group Flow (vph)	703	1014	0	110	1108	0	111	149	0	0	194	554
Enter Blocked Intersection	No	No	No	No	No	No	No	No	No	No	No	No
Lane Alignment	Left	Left	Right	Left	Left	Right	Left	Left	Right	Left	Left	Right
Median Width(ft)		24			24			12				12
Link Offset(ft)		0			0			0				0
Crosswalk Width(ft)		16			16			16				16
Two way Left Turn Lane												
Headway Factor	1.00	1.00	1.00	1.00	1.00	1.00	1.00	1.00	1.00	1.00	1.00	1.00
Turning Speed (mph)	15		60	60		9	60		60	15		9
Number of Detectors	1	2		1	2		1	2		1	2	1
Detector Template	Left	Thru		Left	Thru		Left	Thru		Left	Thru	Right
Leading Detector (ft)	20	100		20	100		20	100		20	100	20
Trailing Detector (ft)	0	0		0	0		0	0		0	0	0
Detector 1 Position(ft)	0	0		0	0		0	0		0	0	0
Detector 1 Size(ft)	20	6		20	6		20	6		20	6	20
Detector 1 Type	Cl+Ex	Cl+Ex		Cl+Ex	Cl+Ex		Cl+Ex	Cl+Ex		Cl+Ex	Cl+Ex	Cl+Ex
Detector 1 Channel												
Detector 1 Extend (s)	0.0	0.0		0.0	0.0		0.0	0.0		0.0	0.0	0.0
Detector 1 Queue (s)	0.0	0.0		0.0	0.0		0.0	0.0		0.0	0.0	0.0
Detector 1 Delay (s)	0.0	0.0		0.0	0.0		0.0	0.0		0.0	0.0	0.0
Detector 2 Position(ft)		94			94			94				94
Detector 2 Size(ft)		6			6			6				6
Detector 2 Type		Cl+Ex			Cl+Ex			Cl+Ex				Cl+Ex
Detector 2 Channel												
Detector 2 Extend (s)		0.0			0.0			0.0				0.0
Turn Type	Prot	NA		Prot	NA		Split	NA		Split	NA	pt+ov

Lanes, Volumes, Timings  
2: Shiloh Road & Hembree Ln

General Plan 2040 Project Altern. C Conditions

Timing Plan: P.M. Peak

Lane Group	EBL	EBT	EBR	WBL	WBT	WBR	NBL	NBT	NBR	SBL	SBT	SBR
Protected Phases	5	2		1	6		8	8		4	4	4 5
Permitted Phases												
Detector Phase	5	2		1	6		8	8		4	4	4 5
Switch Phase												
Minimum Initial (s)	3.0	5.0		5.0	5.0		5.0	5.0		5.0	5.0	
Minimum Split (s)	7.5	9.5		9.5	43.5		9.5	9.5		9.5	9.5	
Total Split (s)	21.0	57.0		9.5	45.5		9.5	9.5		14.0	14.0	
Total Split (%)	23.3%	63.3%		10.6%	50.6%		10.6%	10.6%		15.6%	15.6%	
Maximum Green (s)	17.0	53.0		5.5	41.5		5.5	5.5		10.0	10.0	
Yellow Time (s)	3.0	3.0		3.0	3.0		3.0	3.0		3.0	3.0	
All-Red Time (s)	1.0	1.0		1.0	1.0		1.0	1.0		1.0	1.0	
Lost Time Adjust (s)	0.0	0.0		0.0	0.0		0.0	0.0		0.0	0.0	
Total Lost Time (s)	4.0	4.0		4.0	4.0		4.0	4.0		4.0	4.0	
Lead/Lag	Lead	Lag		Lead	Lag							
Lead-Lag Optimize?	Yes	Yes		Yes	Yes							
Vehicle Extension (s)	3.0	3.0		3.0	3.0		3.0	3.0		3.0	3.0	
Recall Mode	None	None		None	None		None	None		None	None	
Walk Time (s)					7.0							
Flash Don't Walk (s)					32.0							
Pedestrian Calls (#/hr)					1							
Act Effct Green (s)	17.1	50.4		5.5	38.8		5.5	5.5		10.0	27.1	
Actuated g/C Ratio	0.20	0.58		0.06	0.44		0.06	0.06		0.11	0.31	
v/c Ratio	1.05	0.95		0.99	0.71		1.00	0.67		0.96	1.03	
Control Delay (s/veh)	85.4	37.0		127.9	22.2		130.3	27.3		94.4	72.6	
Queue Delay	0.0	4.2		0.0	0.0		0.0	0.0		0.0	0.0	
Total Delay (s/veh)	85.4	41.2		127.9	22.2		130.3	27.3		94.4	72.6	
LOS	F	D		F	C		F	C		F	E	
Approach Delay (s/veh)		59.3			31.8			71.3			78.2	
Approach LOS		E			C			E			E	

Intersection Summary

Area Type:	Other
Cycle Length:	90
Actuated Cycle Length:	87.5
Natural Cycle:	100
Control Type:	Actuated-Uncoordinated
Maximum v/c Ratio:	1.05
Intersection Signal Delay (s/veh):	55.2
Intersection LOS:	E
Intersection Capacity Utilization:	89.6%
ICU Level of Service:	E
Analysis Period (min):	15

Splits and Phases: 2: Shiloh Road & Hembree Ln



Lanes, Volumes, Timings  
3: US 101 NB Off-Ramp & Shiloh Road

General Plan 2040 Project Altern. C Conditions

Timing Plan: P.M. Peak

	→	↘	↙	←	↖	↗
Lane Group	EBT	EBR	WBL	WBT	NBL	NBR
Lane Configurations	↑↑			↑	↘	↗
Traffic Volume (vph)	792	0	0	919	694	783
Future Volume (vph)	792	0	0	919	694	783
Ideal Flow (vphpl)	1900	1900	1900	1900	1900	1900
Storage Length (ft)		0	0		0	265
Storage Lanes		0	0		1	2
Taper Length (ft)			25		25	
Lane Util. Factor	0.95	1.00	1.00	1.00	1.00	0.88
Frt						0.850
Flt Protected					0.950	
Satd. Flow (prot)	3539	0	0	1863	1770	2787
Flt Permitted					0.950	
Satd. Flow (perm)	3539	0	0	1863	1770	2787
Right Turn on Red		Yes				Yes
Satd. Flow (RTOR)						167
Link Speed (mph)	40			40	30	
Link Distance (ft)	186			371	769	
Travel Time (s)	3.2			6.3	17.5	
Peak Hour Factor	0.94	0.94	0.97	0.97	0.90	0.90
Adj. Flow (vph)	843	0	0	947	771	870
Shared Lane Traffic (%)						
Lane Group Flow (vph)	843	0	0	947	771	870
Enter Blocked Intersection	No	No	No	No	No	No
Lane Alignment	Left	Right	Left	Left	Left	Right
Median Width(ft)	0			0	12	
Link Offset(ft)	0			0	0	
Crosswalk Width(ft)	16			16	16	
Two way Left Turn Lane						
Headway Factor	1.00	1.00	1.00	1.00	1.00	1.00
Turning Speed (mph)		9	15		15	9
Number of Detectors	2			2	1	1
Detector Template	Thru			Thru	Left	Right
Leading Detector (ft)	100			100	20	20
Trailing Detector (ft)	0			0	0	0
Detector 1 Position(ft)	0			0	0	0
Detector 1 Size(ft)	6			6	20	20
Detector 1 Type	Cl+Ex			Cl+Ex	Cl+Ex	Cl+Ex
Detector 1 Channel						
Detector 1 Extend (s)	0.0			0.0	0.0	0.0
Detector 1 Queue (s)	0.0			0.0	0.0	0.0
Detector 1 Delay (s)	0.0			0.0	0.0	0.0
Detector 2 Position(ft)	94			94		
Detector 2 Size(ft)	6			6		
Detector 2 Type	Cl+Ex			Cl+Ex		
Detector 2 Channel						
Detector 2 Extend (s)	0.0			0.0		
Turn Type	NA			NA	Prot	Perm
Protected Phases	2			6	8	
Permitted Phases						8

Lanes, Volumes, Timings  
 3: US 101 NB Off-Ramp & Shiloh Road

General Plan 2040 Project Altern. C Conditions

Timing Plan: P.M. Peak



Lane Group	EBT	EBR	WBL	WBT	NBL	NBR
Detector Phase	2			6	8	8
Switch Phase						
Minimum Initial (s)	5.0			5.0	5.0	5.0
Minimum Split (s)	9.0			9.0	9.0	9.0
Total Split (s)	37.0			37.0	35.0	35.0
Total Split (%)	51.4%			51.4%	48.6%	48.6%
Maximum Green (s)	33.0			33.0	31.0	31.0
Yellow Time (s)	3.0			3.0	3.0	3.0
All-Red Time (s)	1.0			1.0	1.0	1.0
Lost Time Adjust (s)	0.0			0.0	0.0	0.0
Total Lost Time (s)	4.0			4.0	4.0	4.0
Lead/Lag						
Lead-Lag Optimize?						
Vehicle Extension (s)	3.0			3.0	3.0	3.0
Recall Mode	None			None	None	None
Act Effect Green (s)	33.0			33.0	31.0	31.0
Actuated g/C Ratio	0.46			0.46	0.43	0.43
v/c Ratio	0.52			1.11	1.01	0.67
Control Delay (s/veh)	15.3			87.9	58.8	16.1
Queue Delay	0.0			0.0	0.0	0.0
Total Delay (s/veh)	15.3			87.9	58.8	16.1
LOS	B			F	E	B
Approach Delay (s/veh)	15.3			87.9	36.2	
Approach LOS	B			F	D	

Intersection Summary

Area Type:	Other
Cycle Length:	72
Actuated Cycle Length:	72
Natural Cycle:	100
Control Type:	Actuated-Uncoordinated
Maximum v/c Ratio:	1.11
Intersection Signal Delay (s/veh):	45.3
Intersection LOS:	D
Intersection Capacity Utilization:	155.6%
ICU Level of Service:	H
Analysis Period (min):	15

Splits and Phases: 3: US 101 NB Off-Ramp & Shiloh Road

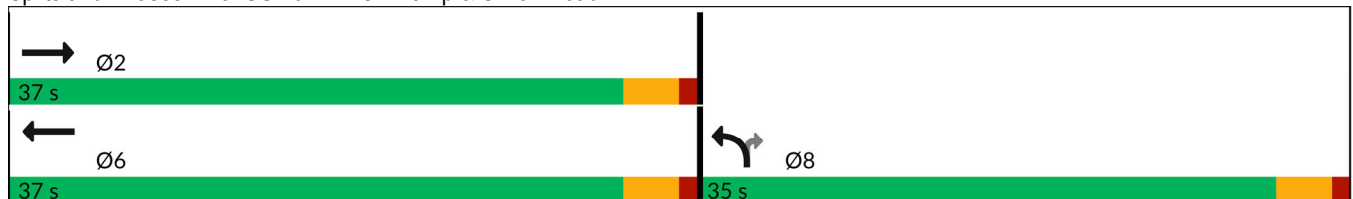

Lanes, Volumes, Timings  
4: Shiloh Road & US 101 SB Off-Ramp

General Plan 2040 Project Altern. C Conditions

Timing Plan: P.M. Peak

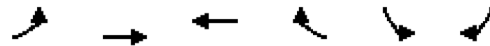

Lane Group	EBL	EBT	WBT	WBR	SBL	SBR
Lane Configurations		↑	↑		↘	↘
Traffic Volume (vph)	0	642	1064	0	348	94
Future Volume (vph)	0	642	1064	0	348	94
Ideal Flow (vphp)	1900	1900	1900	1900	1900	1900
Storage Length (ft)	0			0	0	275
Storage Lanes	0			0	1	1
Taper Length (ft)	25				25	
Lane Util. Factor	1.00	1.00	1.00	1.00	1.00	1.00
Ped Bike Factor						0.98
Frt						0.850
Flt Protected					0.950	
Satd. Flow (prot)	0	1863	1863	0	1770	1583
Flt Permitted					0.950	
Satd. Flow (perm)	0	1863	1863	0	1770	1548
Right Turn on Red				Yes		Yes
Satd. Flow (RTOR)						101
Link Speed (mph)		40	40		30	
Link Distance (ft)		225	306		486	
Travel Time (s)		3.8	5.2		11.0	
Confl. Peds. (#/hr)						1
Peak Hour Factor	0.89	0.89	0.96	0.96	0.93	0.93
Adj. Flow (vph)	0	721	1108	0	374	101
Shared Lane Traffic (%)						
Lane Group Flow (vph)	0	721	1108	0	374	101
Enter Blocked Intersection	No	No	No	No	No	No
Lane Alignment	Left	Left	Left	Right	Left	Right
Median Width(ft)		4	0		12	
Link Offset(ft)		0	0		0	
Crosswalk Width(ft)		16	16		16	
Two way Left Turn Lane						
Headway Factor	1.00	1.00	1.00	1.00	1.00	1.00
Turning Speed (mph)	15			9	15	9
Number of Detectors		2	2		1	1
Detector Template		Thru	Thru		Left	Right
Leading Detector (ft)		100	100		20	20
Trailing Detector (ft)		0	0		0	0
Detector 1 Position(ft)		0	0		0	0
Detector 1 Size(ft)		6	6		20	20
Detector 1 Type		Cl+Ex	Cl+Ex		Cl+Ex	Cl+Ex
Detector 1 Channel						
Detector 1 Extend (s)		0.0	0.0		0.0	0.0
Detector 1 Queue (s)		0.0	0.0		0.0	0.0
Detector 1 Delay (s)		0.0	0.0		0.0	0.0
Detector 2 Position(ft)		94	94			
Detector 2 Size(ft)		6	6			
Detector 2 Type		Cl+Ex	Cl+Ex			
Detector 2 Channel						
Detector 2 Extend (s)		0.0	0.0			
Turn Type		NA	NA		Perm	Perm



Lanes, Volumes, Timings  
4: Shiloh Road & US 101 SB Off-Ramp

General Plan 2040 Project Altern. C Conditions  
Timing Plan: P.M. Peak



Lane Group	EBL	EBT	WBT	WBR	SBL	SBR
Protected Phases		2	6			
Permitted Phases					4	4
Detector Phase		2	6		4	4
Switch Phase						
Minimum Initial (s)		5.0	5.0		5.0	5.0
Minimum Split (s)		9.0	38.0		9.0	9.0
Total Split (s)		69.0	69.0		21.0	21.0
Total Split (%)		76.7%	76.7%		23.3%	23.3%
Maximum Green (s)		65.0	65.0		17.0	17.0
Yellow Time (s)		3.0	3.0		3.0	3.0
All-Red Time (s)		1.0	1.0		1.0	1.0
Lost Time Adjust (s)		0.0	0.0		0.0	0.0
Total Lost Time (s)		4.0	4.0		4.0	4.0
Lead/Lag						
Lead-Lag Optimize?						
Vehicle Extension (s)		3.0	3.0		3.0	3.0
Recall Mode		None	None		None	None
Walk Time (s)			7.0			
Flash Don't Walk (s)			27.0			
Pedestrian Calls (#/hr)			0			
Act Effct Green (s)		49.4	49.4		17.6	17.6
Actuated g/C Ratio		0.66	0.66		0.23	0.23
v/c Ratio		0.59	0.91		0.91	0.23
Control Delay (s/veh)		8.9	22.2		60.2	8.6
Queue Delay		0.0	0.0		0.0	0.0
Total Delay (s/veh)		8.9	22.2		60.2	8.6
LOS		A	C		E	A
Approach Delay (s/veh)		8.9	22.2		49.2	
Approach LOS		A	C		D	

Intersection Summary

Area Type:	Other
Cycle Length:	90
Actuated Cycle Length:	75.2
Natural Cycle:	80
Control Type:	Actuated-Uncoordinated
Maximum v/c Ratio:	0.91
Intersection Signal Delay (s/veh):	23.6
Intersection LOS:	C
Intersection Capacity Utilization:	154.8%
ICU Level of Service:	H
Analysis Period (min):	15

Splits and Phases: 4: Shiloh Road & US 101 SB Off-Ramp

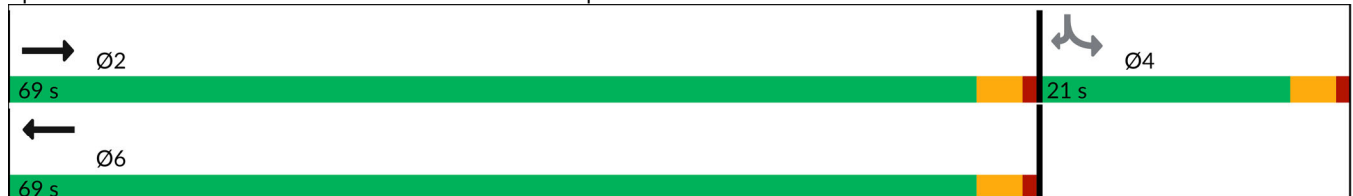

Lanes, Volumes, Timings  
5: Caletti Ave & Shiloh Road



















General Plan 2040 Project Altern. C Conditions

Timing Plan: P.M. Peak

	→	↘	↙	←	↖	↗
Lane Group	EBT	EBR	WBL	WBT	NBL	NBR
Lane Configurations	↑↑		↘	↑	↘	↗
Traffic Volume (vph)	1184	16	105	1123	18	159
Future Volume (vph)	1184	16	105	1123	18	159
Ideal Flow (vphpl)	1900	1900	1900	1900	1900	1900
Storage Length (ft)		0	68		0	0
Storage Lanes		0	1		1	1
Taper Length (ft)			50		25	
Lane Util. Factor	0.95	0.95	1.00	1.00	1.00	1.00
Frt	0.998					0.850
Flt Protected			0.950		0.950	
Satd. Flow (prot)	3532	0	1770	1863	1770	1583
Flt Permitted			0.950		0.950	
Satd. Flow (perm)	3532	0	1770	1863	1770	1583
Link Speed (mph)	40			40	30	
Link Distance (ft)	1081			184	459	
Travel Time (s)	18.4			3.1	10.4	
Peak Hour Factor	0.89	0.89	0.92	0.92	0.89	0.89
Adj. Flow (vph)	1330	18	114	1221	20	179
Shared Lane Traffic (%)						
Lane Group Flow (vph)	1348	0	114	1221	20	179
Enter Blocked Intersection	No	No	No	No	No	No
Lane Alignment	Left	Right	Left	Left	Left	Right
Median Width(ft)	12			12	12	
Link Offset(ft)	0			0	0	
Crosswalk Width(ft)	16			16	16	
Two way Left Turn Lane						
Headway Factor	1.00	1.00	1.00	1.00	1.00	1.00
Turning Speed (mph)		9	15		15	9
Sign Control	Free			Free	Stop	
<b>Intersection Summary</b>						
Area Type:	Other					
Control Type:	Unsignalized					
Intersection Capacity Utilization	69.1%			ICU Level of Service C		
Analysis Period (min)	15					

Lanes, Volumes, Timings  
6: Conde Lane & Shiloh Road

General Plan 2040 Project Altern. C Conditions  
Timing Plan: P.M. Peak

												
Lane Group	EBL	EBT	EBR	WBL	WBT	WBR	NBL	NBT	NBR	SBL	SBT	SBR
Lane Configurations												
Traffic Volume (vph)	77	707	0	9	727	372	4	2	16	387	4	65
Future Volume (vph)	77	707	0	9	727	372	4	2	16	387	4	65
Ideal Flow (vphpl)	1900	1900	1900	1900	1900	1900	1900	1900	1900	1900	1900	1900
Storage Length (ft)	90		0	127		0	0		0	0		40
Storage Lanes	1		0	1		0	0		0	0		1
Taper Length (ft)	70			40			25			25		
Lane Util. Factor	1.00	0.95	0.95	1.00	0.95	0.95	1.00	1.00	1.00	1.00	1.00	1.00
Ped Bike Factor	1.00				0.99							
Frt					0.949			0.901				0.850
Flt Protected	0.950			0.950				0.991			0.953	
Satd. Flow (prot)	1770	3539	0	1770	3334	0	0	1663	0	0	1775	1583
Flt Permitted	0.950			0.950				0.991			0.953	
Satd. Flow (perm)	1768	3539	0	1770	3334	0	0	1663	0	0	1775	1583
Right Turn on Red			Yes			Yes			Yes			No
Satd. Flow (RTOR)					94			25				
Link Speed (mph)		40			40			30				35
Link Distance (ft)		815			1081			418				522
Travel Time (s)		13.9			18.4			9.5				10.2
Confl. Peds. (#/hr)	1						1					
Peak Hour Factor	0.88	0.88	0.88	0.80	0.80	0.80	0.63	0.63	0.63	0.88	0.88	0.88
Adj. Flow (vph)	88	803	0	11	909	465	6	3	25	440	5	74
Shared Lane Traffic (%)												
Lane Group Flow (vph)	88	803	0	11	1374	0	0	34	0	0	445	74
Enter Blocked Intersection	No	No	No	No	No	No	No	No	No	No	No	No
Lane Alignment	Left	Left	Right	Left	Left	Right	Left	Left	Right	Left	Left	Right
Median Width(ft)		12			12			0				0
Link Offset(ft)		0			0			0				0
Crosswalk Width(ft)		16			16			16				16
Two way Left Turn Lane												
Headway Factor	1.00	1.00	1.00	1.00	1.00	1.00	1.00	1.00	1.00	1.00	1.00	1.00
Turning Speed (mph)	15		9	15		9	15		9	15		9
Number of Detectors	1	2		1	2		1	2		1	1	1
Detector Template	Left	Thru		Left	Thru		Left	Thru		Left	Thru	Right
Leading Detector (ft)	20	100		20	100		20	100		20	30	20
Trailing Detector (ft)	0	0		0	0		0	0		0	0	0
Detector 1 Position(ft)	0	0		0	0		0	0		0	0	0
Detector 1 Size(ft)	20	6		20	6		20	6		20	30	20
Detector 1 Type	Cl+Ex	Cl+Ex		Cl+Ex	Cl+Ex		Cl+Ex	Cl+Ex		Cl+Ex	Cl+Ex	Cl+Ex
Detector 1 Channel												
Detector 1 Extend (s)	0.0	0.0		0.0	0.0		0.0	0.0		0.0	0.0	0.0
Detector 1 Queue (s)	0.0	0.0		0.0	0.0		0.0	0.0		0.0	0.0	0.0
Detector 1 Delay (s)	0.0	0.0		0.0	0.0		0.0	0.0		0.0	0.0	0.0
Detector 2 Position(ft)		94			94			94				
Detector 2 Size(ft)		6			6			6				
Detector 2 Type		Cl+Ex			Cl+Ex			Cl+Ex				
Detector 2 Channel												
Detector 2 Extend (s)		0.0			0.0			0.0				
Turn Type	Prot	NA		Prot	NA		Split	NA		Split	NA	custom

Lanes, Volumes, Timings  
6: Conde Lane & Shiloh Road

General Plan 2040 Project Altern. C Conditions

Timing Plan: P.M. Peak

Lane Group	EBL	EBT	EBR	WBL	WBT	WBR	NBL	NBT	NBR	SBL	SBT	SBR
Protected Phases	5	2		1	6		7	7		4	4	
Permitted Phases												6
Detector Phase	5	2		1	6		7	7		4	4	6
Switch Phase												
Minimum Initial (s)	8.0	8.0		8.0	8.0		10.0	10.0		11.0	11.0	8.0
Minimum Split (s)	12.0	46.0		12.0	12.0		37.0	37.0		15.0	15.0	12.0
Total Split (s)	13.0	46.0		12.0	45.0		37.0	37.0		15.0	15.0	45.0
Total Split (%)	11.8%	41.8%		10.9%	40.9%		33.6%	33.6%		13.6%	13.6%	40.9%
Maximum Green (s)	9.0	42.0		8.0	41.0		33.0	33.0		11.0	11.0	41.0
Yellow Time (s)	3.0	3.0		3.0	3.0		3.0	3.0		3.0	3.0	3.0
All-Red Time (s)	1.0	1.0		1.0	1.0		1.0	1.0		1.0	1.0	1.0
Lost Time Adjust (s)	0.0	0.0		0.0	0.0		0.0	0.0		0.0	0.0	0.0
Total Lost Time (s)	4.0	4.0		4.0	4.0		4.0	4.0		4.0	4.0	4.0
Lead/Lag	Lead	Lag		Lead	Lag							Lag
Lead-Lag Optimize?	Yes	Yes		Yes	Yes							Yes
Vehicle Extension (s)	3.0	3.0		3.0	3.0		3.0	3.0		3.0	3.0	3.0
Recall Mode	None	None		None	None		None	None		None	None	None
Walk Time (s)		7.0					7.0	7.0				
Flash Don't Walk (s)		35.0					26.0	26.0				
Pedestrian Calls (#/hr)		0					0	0				
Act Effct Green (s)	8.7	49.4		8.2	41.9		10.2	10.2		11.2	11.2	41.9
Actuated g/C Ratio	0.11	0.63		0.10	0.53		0.13	0.13		0.14	0.14	0.53
v/c Ratio	0.45	0.36		0.06	0.75		0.14	0.14		1.75	1.75	0.09
Control Delay (s/veh)	44.0	9.3		37.1	19.2		19.5	19.5		381.4	381.4	12.6
Queue Delay	0.0	0.0		0.0	0.0		0.0	0.0		0.0	0.0	0.0
Total Delay (s/veh)	44.0	9.3		37.1	19.2		19.5	19.5		381.4	381.4	12.6
LOS	D	A		D	B		B	B		F	F	B
Approach Delay (s/veh)		12.7			19.3		19.5	19.5		328.8	328.8	
Approach LOS		B			B		B	B		F	F	

Intersection Summary

Area Type:	Other
Cycle Length:	110
Actuated Cycle Length:	78.6
Natural Cycle:	150
Control Type:	Actuated-Uncoordinated
Maximum v/c Ratio:	1.75
Intersection Signal Delay (s/veh):	74.0
Intersection LOS:	E
Intersection Capacity Utilization:	77.0%
ICU Level of Service:	D
Analysis Period (min):	15

















Splits and Phases: 6: Conde Lane & Shiloh Road



Lanes, Volumes, Timings  
7: Entrance 1/Gridley Drive & Shiloh Road

General Plan 2040 Project Altern. C Conditions

Timing Plan: P.M. Peak

												
Lane Group	EBL	EBT	EBR	WBL	WBT	WBR	NBL	NBT	NBR	SBL	SBT	SBR
Lane Configurations												
Traffic Volume (vph)	25	152	70	5	185	0	66	0	5	0	0	21
Future Volume (vph)	25	152	70	5	185	0	66	0	5	0	0	21
Ideal Flow (vphpl)	1900	1900	1900	1900	1900	1900	1900	1900	1900	1900	1900	1900
Lane Util. Factor	1.00	1.00	1.00	1.00	1.00	1.00	1.00	1.00	1.00	1.00	1.00	1.00
Ped Bike Factor												
Frt		0.962						0.850			0.865	
Flt Protected		0.995			0.999		0.950					
Satd. Flow (prot)	0	1783	0	0	1861	0	1770	1583	0	0	1611	0
Flt Permitted		0.995			0.999		0.950					
Satd. Flow (perm)	0	1783	0	0	1861	0	1770	1583	0	0	1611	0
Link Speed (mph)		40			40			30			30	
Link Distance (ft)		608			2146			248			715	
Travel Time (s)		10.4			36.6			5.6			16.3	
Confl. Peds. (#/hr)	1											
Confl. Bikes (#/hr)			1									
Peak Hour Factor	0.94	0.94	0.94	0.69	0.69	0.69	1.00	1.00	1.00	0.58	0.58	0.58
Adj. Flow (vph)	27	162	74	7	268	0	66	0	5	0	0	36
Shared Lane Traffic (%)												
Lane Group Flow (vph)	0	263	0	0	275	0	66	5	0	0	36	0
Enter Blocked Intersection	No	No	No	No	No	No	No	No	No	No	No	No
Lane Alignment	Left	Left	Right	Left	Left	Right	Left	Left	Right	Left	Left	Right
Median Width(ft)		0			0			12			12	
Link Offset(ft)		0			0			0			0	
Crosswalk Width(ft)		16			16			16			16	
Two way Left Turn Lane												
Headway Factor	1.00	1.00	1.00	1.00	1.00	1.00	1.00	1.00	1.00	1.00	1.00	1.00
Turning Speed (mph)	15		9	15		9	15		9	15		9
Sign Control		Free			Free			Stop			Stop	



















Intersection Summary

Area Type:	Other
Control Type:	Unsignalized
Intersection Capacity Utilization	41.9%
ICU Level of Service	A
Analysis Period (min)	15

Lanes, Volumes, Timings  
8: Old Redwood Hwy & Entrance 1

General Plan 2040 Project Altern. C Conditions

Timing Plan: P.M. Peak

												
Lane Group	EBL	EBT	EBR	WBL	WBT	WBR	NBL	NBT	NBR	SBL	SBT	SBR
Lane Configurations												
Traffic Volume (vph)	4	0	0	9	0	15	0	1195	10	16	1152	0
Future Volume (vph)	4	0	0	9	0	15	0	1195	10	16	1152	0
Ideal Flow (vphp)	1900	1900	1900	1900	1900	1900	1900	1900	1900	1900	1900	1900
Storage Length (ft)	0		0	0		0	0		0	50		0
Storage Lanes	0		0	1		0	0		0	1		0
Taper Length (ft)	25			25			25			25		
Lane Util. Factor	1.00	1.00	1.00	1.00	1.00	1.00	1.00	1.00	1.00	1.00	1.00	1.00
Ped Bike Factor												
Frt					0.850			0.999				
Flt Protected		0.950		0.950						0.950		
Satd. Flow (prot)	0	1770	0	1770	1583	0	0	1861	0	1770	1863	0
Flt Permitted		0.950		0.950						0.950		
Satd. Flow (perm)	0	1770	0	1770	1583	0	0	1861	0	1770	1863	0
Link Speed (mph)		30			30			45			45	
Link Distance (ft)		98			385			520			748	
Travel Time (s)		2.2			8.8			7.9			11.3	
Confl. Bikes (#/hr)									3			5
Peak Hour Factor	0.38	0.38	0.38	1.00	1.00	1.00	0.91	0.91	0.91	0.94	0.94	0.94
Adj. Flow (vph)	11	0	0	9	0	15	0	1313	11	17	1226	0
Shared Lane Traffic (%)												
Lane Group Flow (vph)	0	11	0	9	15	0	0	1324	0	17	1226	0
Enter Blocked Intersection	No	No	No	No	No	No	No	No	No	No	No	No
Lane Alignment	Left	Left	Right	Left	Left	Right	Left	Left	Right	Left	Left	Right
Median Width(ft)		12			12			12			12	
Link Offset(ft)		0			0			0			0	
Crosswalk Width(ft)		16			16			16			16	
Two way Left Turn Lane												
Headway Factor	1.00	1.00	1.00	1.00	1.00	1.00	1.00	1.00	1.00	1.00	1.00	1.00
Turning Speed (mph)	15		9	15		9	15		9	15		9
Sign Control		Stop			Stop			Free			Free	
<b>Intersection Summary</b>												
Area Type:	Other											
Control Type:	Unsignalized											
Intersection Capacity Utilization	73.5%						ICU Level of Service D					
Analysis Period (min)	15											

Lanes, Volumes, Timings  
9: Entrance 2 & Shiloh Road

General Plan 2040 Project Altern. C Conditions

Timing Plan: P.M. Peak

	→	↘	↙	←	↖	↗
Lane Group	EBT	EBR	WBL	WBT	NBL	NBR
Lane Configurations	↗			↖	↘	↗
Traffic Volume (vph)	125	0	0	169	0	0
Future Volume (vph)	125	0	0	169	0	0
Ideal Flow (vphpl)	1900	1900	1900	1900	1900	1900
Lane Util. Factor	1.00	1.00	1.00	1.00	1.00	1.00
<b>Fr</b>						
<b>Flt Protected</b>						
Satd. Flow (prot)	1863	0	0	1863	1863	1863
<b>Flt Permitted</b>						
Satd. Flow (perm)	1863	0	0	1863	1863	1863
Link Speed (mph)	40			40	30	
Link Distance (ft)	2146			134	402	
Travel Time (s)	36.6			2.3	9.1	
Peak Hour Factor	0.92	0.92	0.68	0.68	1.00	1.00
Adj. Flow (vph)	136	0	0	249	0	0
<b>Shared Lane Traffic (%)</b>						
Lane Group Flow (vph)	136	0	0	249	0	0
Enter Blocked Intersection	No	No	No	No	No	No
Lane Alignment	Left	Right	Left	Left	Left	Right
Median Width(ft)	0			0	12	
Link Offset(ft)	0			0	0	
Crosswalk Width(ft)	16			16	16	
<b>Two way Left Turn Lane</b>						
Headway Factor	1.00	1.00	1.00	1.00	1.00	1.00
Turning Speed (mph)		9	15		15	9
Sign Control	Free			Free	Stop	
<b>Intersection Summary</b>						
Area Type:	Other					
Control Type:	Unsignalized					
Intersection Capacity Utilization	12.2%			ICU Level of Service A		
Analysis Period (min)	15					

Lanes, Volumes, Timings

General Plan 2040 Project Altern. C Conditions

10: US 101 NB Off Ramp/Lakewood Drive & Old Redwood Highway

Timing Plan: P.M. Peak



Lane Group	EBL	EBT	EBR	WBL	WBT	WBR	NBL	NBT	NBR	SBL	SBT	SBR
Lane Configurations	↔↔	↑			↔↔		↔	↔↔		↔↔		↔
Traffic Volume (vph)	309	682	0	0	724	270	528	539	303	386	0	618
Future Volume (vph)	309	682	0	0	724	270	528	539	303	386	0	618
Ideal Flow (vphpl)	1900	1900	1900	1900	1900	1900	1900	1900	1900	1900	1900	1900
Storage Length (ft)	155		0	0		0	270		150	120		0
Storage Lanes	1		0	0		0	1		1	1		1
Taper Length (ft)	50			25			165			75		
Lane Util. Factor	0.97	1.00	1.00	1.00	0.95	0.95	0.91	0.91	0.95	0.97	1.00	1.00
Ped Bike Factor	1.00				0.99			0.99		1.00		
Fr <sub>t</sub>					0.959			0.950				0.850
Fl <sub>t</sub> Protected	0.950						0.950	0.996		0.950		
Satd. Flow (prot)	3433	1863	0	0	3374	0	1610	3187	0	3433	0	1583
Fl <sub>t</sub> Permitted	0.950						0.950	0.996		0.950		
Satd. Flow (perm)	3429	1863	0	0	3374	0	1610	3187	0	3422	0	1583
Right Turn on Red			Yes			Yes			Yes			Yes
Satd. Flow (RTOR)					61			89				247
Link Speed (mph)		35			35			30				30
Link Distance (ft)		226			617			716				478
Travel Time (s)		4.4			12.0			16.3				10.9
Confl. Peds. (#/hr)	3		1	1		3			8	8		
Confl. Bikes (#/hr)			2			9						
Peak Hour Factor	0.87	0.87	0.87	0.91	0.91	0.91	0.92	0.92	0.92	0.96	0.96	0.96
Adj. Flow (vph)	355	784	0	0	796	297	574	586	329	402	0	644
Shared Lane Traffic (%)							13%					
Lane Group Flow (vph)	355	784	0	0	1093	0	499	990	0	402	0	644
Enter Blocked Intersection	No	No	No	No	No	No	No	No	No	No	No	No
Lane Alignment	Left	Left	Right	Left	Left	Right	Left	Left	Right	Left	Left	Right
Median Width(ft)		24			24			24				24
Link Offset(ft)		0			0			0				0
Crosswalk Width(ft)		16			16			16				16
Two way Left Turn Lane												
Headway Factor	1.00	1.00	1.00	1.00	1.00	1.00	1.00	1.00	1.00	1.00	1.00	1.00
Turning Speed (mph)	15		9	15		9	15		9	15		9
Number of Detectors	1	2			2		1	2		1		1
Detector Template	Left	Thru			Thru		Left	Thru		Left		Right
Leading Detector (ft)	20	100			100		20	100		20		20
Trailing Detector (ft)	0	0			0		0	0		0		0
Detector 1 Position(ft)	0	0			0		0	0		0		0
Detector 1 Size(ft)	20	6			6		20	6		20		20
Detector 1 Type	Cl+Ex	Cl+Ex			Cl+Ex		Cl+Ex	Cl+Ex		Cl+Ex		Cl+Ex
Detector 1 Channel												
Detector 1 Extend (s)	0.0	0.0			0.0		0.0	0.0		0.0		0.0
Detector 1 Queue (s)	0.0	0.0			0.0		0.0	0.0		0.0		0.0
Detector 1 Delay (s)	0.0	0.0			0.0		0.0	0.0		0.0		0.0
Detector 2 Position(ft)		94			94			94				
Detector 2 Size(ft)		6			6			6				
Detector 2 Type		Cl+Ex			Cl+Ex			Cl+Ex				
Detector 2 Channel												
Detector 2 Extend (s)		0.0			0.0			0.0				



Lanes, Volumes, Timings

General Plan 2040 Project Altern. C Conditions

10: US 101 NB Off Ramp/Lakewood Drive & Old Redwood Highway

Timing Plan: P.M. Peak



Lane Group	EBL	EBT	EBR	WBL	WBT	WBR	NBL	NBT	NBR	SBL	SBT	SBR
Turn Type	Prot	NA			NA		Split	NA		Prot		pm+ov
Protected Phases	5	2			6		8	8		7		5
Permitted Phases												5 8
Detector Phase	5	2			6		8	8		7		5
Switch Phase												
Minimum Initial (s)	7.0	10.0			10.0		10.0	10.0		7.0		7.0
Minimum Split (s)	11.0	32.1			32.1		33.7	33.7		11.0		11.0
Total Split (s)	13.0	45.3			32.3		33.7	33.7		11.0		13.0
Total Split (%)	14.4%	50.3%			35.9%		37.4%	37.4%		12.2%		14.4%
Maximum Green (s)	9.0	40.2			27.2		29.0	29.0		7.0		9.0
Yellow Time (s)	3.0	4.1			4.1		3.7	3.7		3.0		3.0
All-Red Time (s)	1.0	1.0			1.0		1.0	1.0		1.0		1.0
Lost Time Adjust (s)	0.0	0.0			0.0		0.0	0.0		0.0		0.0
Total Lost Time (s)	4.0	5.1			5.1		4.7	4.7		4.0		4.0
Lead/Lag	Lead				Lag		Lag	Lag		Lead		Lead
Lead-Lag Optimize?	Yes				Yes		Yes	Yes		Yes		Yes
Vehicle Extension (s)	3.0	3.0			3.0		3.0	3.0		3.0		3.0
Recall Mode	None	Max			Max		None	None		None		None
Walk Time (s)		7.0			7.0		7.0	7.0				
Flash Don't Walk (s)		20.0			17.0		22.0	22.0				
Pedestrian Calls (#/hr)		0			0		0	0				
Act Effct Green (s)	9.0	40.2			27.2		29.0	29.0		7.0		42.7
Actuated g/C Ratio	0.10	0.45			0.30		0.32	0.32		0.08		0.47
v/c Ratio	1.03	0.94			1.03		0.96	0.91		1.51		0.73
Control Delay (s/veh)	99.4	45.4			66.0		63.3	40.3		277.9		17.1
Queue Delay	0.0	0.0			0.0		0.0	0.0		0.0		0.0
Total Delay (s/veh)	99.4	45.4			66.0		63.3	40.3		277.9		17.1
LOS	F	D			E		E	D		F		B
Approach Delay (s/veh)		62.2			66.0			48.0				117.3
Approach LOS		E			E			D				F

Intersection Summary

Area Type: Other  
 Cycle Length: 90  
 Actuated Cycle Length: 90  
 Natural Cycle: 110  
 Control Type: Actuated-Uncoordinated  
 Maximum v/c Ratio: 1.51  
 Intersection Signal Delay (s/veh): 70.7  
 Intersection LOS: E  
 Intersection Capacity Utilization 105.3%  
 ICU Level of Service G  
 Analysis Period (min) 15

Splits and Phases: 10: US 101 NB Off Ramp/Lakewood Drive & Old Redwood Highway

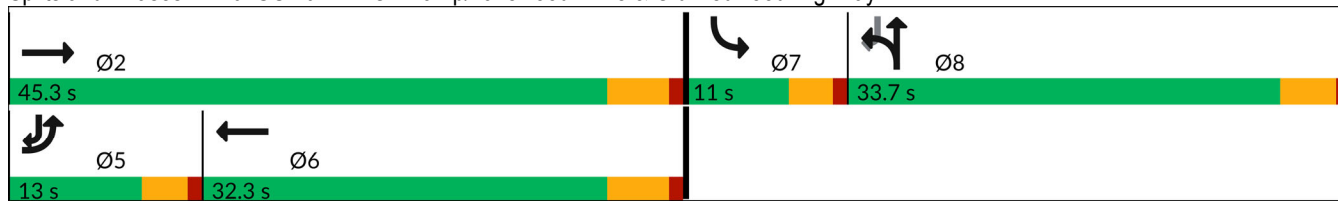

Lanes, Volumes, Timings  
 11: Old Redwood Highway & US 101 NB On Ramp

General Plan 2040 Project Altern. C Conditions

Timing Plan: P.M. Peak

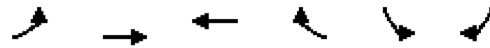

Lane Group	EBL	EBT	WBT	WBR	SBL	SBR
Lane Configurations						
Traffic Volume (vph)	0	991	1564	297	0	0
Future Volume (vph)	0	991	1564	297	0	0
Ideal Flow (vphpl)	1900	1900	1900	1900	1900	1900
Storage Length (ft)	245			0	0	0
Storage Lanes	1			0	0	0
Taper Length (ft)	50				25	
Lane Util. Factor	1.00	0.95	0.95	0.95	1.00	1.00
Ped Bike Factor						
Frt			0.976			
Flt Protected						
Satd. Flow (prot)	1863	3539	3454	0	0	0
Flt Permitted						
Satd. Flow (perm)	1863	3539	3454	0	0	0
Link Speed (mph)		35	35		30	
Link Distance (ft)		531	226		299	
Travel Time (s)		10.3	4.4		6.8	
Confl. Peds. (#/hr)	17			17		
Confl. Bikes (#/hr)				8		
Peak Hour Factor	0.85	0.85	0.91	0.91	0.25	0.25
Adj. Flow (vph)	0	1166	1719	326	0	0
Shared Lane Traffic (%)						
Lane Group Flow (vph)	0	1166	2045	0	0	0
Enter Blocked Intersection	No	No	No	No	No	No
Lane Alignment	Left	Left	Left	Right	Left	Right
Median Width(ft)		12	12		0	
Link Offset(ft)		0	0		0	
Crosswalk Width(ft)		16	16		16	
Two way Left Turn Lane						
Headway Factor	1.00	1.00	1.00	1.00	1.00	1.00
Turning Speed (mph)	15			9	15	9
Sign Control		Free	Free		Free	

Intersection Summary

Area Type:	Other
Control Type:	Unsignalized
Intersection Capacity Utilization	82.7%
Analysis Period (min)	15
	ICU Level of Service E

Lanes, Volumes, Timings

General Plan 2040 Project Altern. C Conditions

12: US 101 SB On Ramp/US 101 SB Off Ramp & Old Redwood Highway

Timing Plan: P.M. Peak



Lane Group	EBL	EBT	EBR	WBL	WBT	WBR	NBL	NBT	NBR	SBL	SBT	SBR
Lane Configurations		↑↑	↗	↘	↑↑					↘	↕	
Traffic Volume (vph)	0	612	501	443	1121	0	0	0	0	311	2	221
Future Volume (vph)	0	612	501	443	1121	0	0	0	0	311	2	221
Ideal Flow (vphpl)	1900	1900	1900	1900	1900	1900	1900	1900	1900	1900	1900	1900
Storage Length (ft)	0		0	250		0	0		0	420		0
Storage Lanes	0		1	0		0	0		0	1		0
Taper Length (ft)	25			165			25			75		
Lane Util. Factor	1.00	0.95	1.00	1.00	0.95	1.00	1.00	1.00	1.00	0.95	0.95	1.00
Ped Bike Factor			0.98	1.00								
Frt			0.850								0.870	
Flt Protected				0.950						0.950	0.994	
Satd. Flow (prot)	0	3539	1583	1770	3539	0	0	0	0	1681	1530	0
Flt Permitted				0.950						0.950	0.994	
Satd. Flow (perm)	0	3539	1558	1768	3539	0	0	0	0	1681	1530	0
Right Turn on Red			Yes			Yes			Yes			Yes
Satd. Flow (RTOR)			443								98	
Link Speed (mph)		35			35			30			30	
Link Distance (ft)		423			531			621			831	
Travel Time (s)		8.2			10.3			14.1			18.9	
Confl. Peds. (#/hr)	19		2	2		18						
Confl. Bikes (#/hr)			4			2						
Peak Hour Factor	0.94	0.94	0.94	0.89	0.89	0.89	0.25	0.25	0.25	0.83	0.83	0.83
Adj. Flow (vph)	0	651	533	498	1260	0	0	0	0	375	2	266
Shared Lane Traffic (%)										10%		
Lane Group Flow (vph)	0	651	533	498	1260	0	0	0	0	337	306	0
Enter Blocked Intersection	No	No	No	No	No	No	No	No	No	No	No	No
Lane Alignment	Left	Left	Right	Left	Left	Right	Left	Left	Right	Left	Left	Right
Median Width(ft)		24			24			12			12	
Link Offset(ft)		0			0			0			0	
Crosswalk Width(ft)		16			16			16			16	
Two way Left Turn Lane												
Headway Factor	1.00	1.00	1.00	1.00	1.00	1.00	1.00	1.00	1.00	1.00	1.00	1.00
Turning Speed (mph)	15		9	15		9	15		9	15		9
Number of Detectors		2	1	1	2					1	2	
Detector Template		Thru	Right	Left	Thru					Left	Thru	
Leading Detector (ft)		100	20	20	100					20	100	
Trailing Detector (ft)		0	0	0	0					0	0	
Detector 1 Position(ft)		0	0	0	0					0	0	
Detector 1 Size(ft)		6	20	20	6					20	6	
Detector 1 Type		Cl+Ex	Cl+Ex	Cl+Ex	Cl+Ex					Cl+Ex	Cl+Ex	
Detector 1 Channel												
Detector 1 Extend (s)		0.0	0.0	0.0	0.0					0.0	0.0	
Detector 1 Queue (s)		0.0	0.0	0.0	0.0					0.0	0.0	
Detector 1 Delay (s)		0.0	0.0	0.0	0.0					0.0	0.0	
Detector 2 Position(ft)		94			94							94
Detector 2 Size(ft)		6			6							6
Detector 2 Type		Cl+Ex			Cl+Ex							Cl+Ex
Detector 2 Channel												
Detector 2 Extend (s)		0.0			0.0							0.0

Lanes, Volumes, Timings

General Plan 2040 Project Altern. C Conditions

12: US 101 SB On Ramp/US 101 SB Off Ramp & Old Redwood Highway

Timing Plan: P.M. Peak



Lane Group	EBL	EBT	EBR	WBL	WBT	WBR	NBL	NBT	NBR	SBL	SBT	SBR
Turn Type		NA	Perm	Prot	NA					Perm	NA	
Protected Phases		6		5	2						8	
Permitted Phases			6							8		
Detector Phase		6	6	5	2					8	8	
Switch Phase												
Minimum Initial (s)		10.0	10.0	7.0	10.0					10.0	10.0	
Minimum Split (s)		32.1	32.1	11.0	38.1					14.7	14.7	
Total Split (s)		33.0	33.0	22.0	55.0					15.0	15.0	
Total Split (%)		47.1%	47.1%	31.4%	78.6%					21.4%	21.4%	
Maximum Green (s)		27.9	27.9	18.0	49.9					10.3	10.3	
Yellow Time (s)		4.1	4.1	3.0	4.1					3.7	3.7	
All-Red Time (s)		1.0	1.0	1.0	1.0					1.0	1.0	
Lost Time Adjust (s)		0.0	0.0	0.0	0.0					0.0	0.0	
Total Lost Time (s)		5.1	5.1	4.0	5.1					4.7	4.7	
Lead/Lag		Lag	Lag	Lead								
Lead-Lag Optimize?		Yes	Yes	Yes								
Vehicle Extension (s)		3.0	3.0	3.0	3.0					3.0	3.0	
Recall Mode		Max	Max	None	Max					None	None	
Walk Time (s)		7.0	7.0		7.0							
Flash Don't Walk (s)		20.0	20.0		25.0							
Pedestrian Calls (#/hr)		0	0		0							
Act Effct Green (s)		27.9	27.9	18.0	49.9					10.3	10.3	
Actuated g/C Ratio		0.40	0.40	0.26	0.71					0.15	0.15	
v/c Ratio		0.46	0.60	1.09	0.50					1.36	0.99	
Control Delay (s/veh)		16.8	6.4	98.8	5.3					216.5	74.1	
Queue Delay		0.0	0.0	0.0	0.0					0.0	0.0	
Total Delay (s/veh)		16.8	6.4	98.8	5.3					216.5	74.1	
LOS		B	A	F	A					F	E	
Approach Delay (s/veh)		12.2			31.8						148.7	
Approach LOS		B			C						F	

Intersection Summary

Area Type: Other

Cycle Length: 70

Actuated Cycle Length: 70

Natural Cycle: 90

Control Type: Actuated-Uncoordinated

Maximum v/c Ratio: 1.36

Intersection Signal Delay (s/veh): 46.3

Intersection LOS: D

Intersection Capacity Utilization 82.7%

ICU Level of Service E

Analysis Period (min) 15



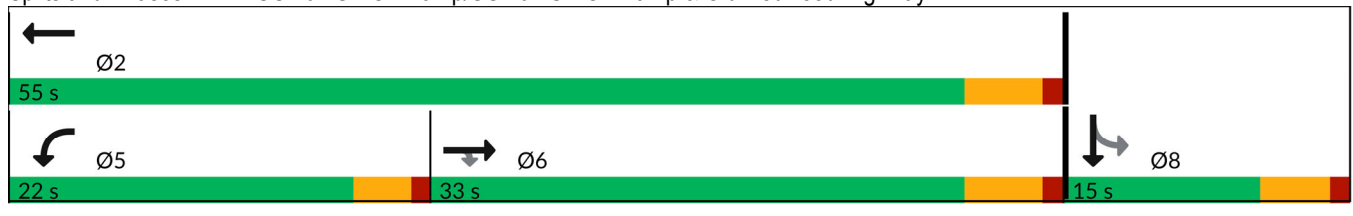



















Splits and Phases: 12: US 101 SB On Ramp/US 101 SB Off Ramp & Old Redwood Highway



Lanes, Volumes, Timings  
1: Old Redwood Hwy & Shiloh Road

General Plan 2040 Project Altern. C Conditions

Timing Plan: Saturday Midday Peak

												
Lane Group	EBL	EBT	EBR	WBL	WBT	WBR	NBL	NBT	NBR	SBL	SBT	SBR
Lane Configurations												
Traffic Volume (vph)	182	209	240	31	222	37	248	342	35	44	275	266
Future Volume (vph)	182	209	240	31	222	37	248	342	35	44	275	266
Ideal Flow (vphpl)	1900	1900	1900	1900	1900	1900	1900	1900	1900	1900	1900	1900
Storage Length (ft)	375		140	0		50	200		98	130		93
Storage Lanes	1		1	0		1	1		1	1		1
Taper Length (ft)	50			25			60			93		
Lane Util. Factor	1.00	1.00	1.00	1.00	1.00	1.00	1.00	1.00	1.00	1.00	1.00	1.00
Ped Bike Factor	1.00		0.98						0.98			0.97
Frt			0.850			0.850			0.850			0.850
Flt Protected	0.950				0.994		0.950			0.950		
Satd. Flow (prot)	1770	1863	1583	0	1852	1583	1770	1863	1583	1770	1863	1583
Flt Permitted	0.950				0.994		0.950			0.950		
Satd. Flow (perm)	1761	1863	1549	0	1852	1583	1770	1863	1550	1770	1863	1540
Right Turn on Red			Yes			Yes			Yes			Yes
Satd. Flow (RTOR)			261			113			81			164
Link Speed (mph)		40			40			45			40	
Link Distance (ft)		1789			608			748			775	
Travel Time (s)		30.5			10.4			11.3			13.2	
Confl. Peds. (#/hr)	4											
Confl. Bikes (#/hr)			1						1			5
Peak Hour Factor	0.89	0.89	0.89	0.86	0.86	0.86	0.93	0.93	0.93	0.91	0.91	0.91
Adj. Flow (vph)	204	235	270	36	258	43	267	368	38	48	302	292
Shared Lane Traffic (%)												
Lane Group Flow (vph)	204	235	270	0	294	43	267	368	38	48	302	292
Enter Blocked Intersection	No	No	No	No	No	No	No	No	No	No	No	No
Lane Alignment	Left	Left	Right	Left	Left	Right	Left	Left	Right	Left	Left	Right
Median Width(ft)		12			12			12			12	
Link Offset(ft)		0			0			0			0	
Crosswalk Width(ft)		16			16			16			16	
Two way Left Turn Lane												
Headway Factor	1.00	1.00	1.00	1.00	1.00	1.00	1.00	1.00	1.00	1.00	1.00	1.00
Turning Speed (mph)	15		9	15		9	15		9	15		9
Number of Detectors	1	2	1	1	2	1	1	2	1	1	2	1
Detector Template	Left	Thru	Right	Left	Thru	Right	Left	Thru	Right	Left	Thru	Right
Leading Detector (ft)	20	100	20	20	100	20	20	100	20	20	100	20
Trailing Detector (ft)	0	0	0	0	0	0	0	0	0	0	0	0
Detector 1 Position(ft)	0	0	0	0	0	0	0	0	0	0	0	0
Detector 1 Size(ft)	20	6	20	20	6	20	20	6	20	20	6	20
Detector 1 Type	Cl+Ex	Cl+Ex	Cl+Ex	Cl+Ex	Cl+Ex	Cl+Ex	Cl+Ex	Cl+Ex	Cl+Ex	Cl+Ex	Cl+Ex	Cl+Ex
Detector 1 Channel												
Detector 1 Extend (s)	0.0	0.0	0.0	0.0	0.0	0.0	0.0	0.0	0.0	0.0	0.0	0.0
Detector 1 Queue (s)	0.0	0.0	0.0	0.0	0.0	0.0	0.0	0.0	0.0	0.0	0.0	0.0
Detector 1 Delay (s)	0.0	0.0	0.0	0.0	0.0	0.0	0.0	0.0	0.0	0.0	0.0	0.0
Detector 2 Position(ft)		94			94			94			94	
Detector 2 Size(ft)		6			6			6			6	
Detector 2 Type		Cl+Ex			Cl+Ex			Cl+Ex			Cl+Ex	
Detector 2 Channel												
Detector 2 Extend (s)		0.0			0.0			0.0			0.0	

Lanes, Volumes, Timings  
1: Old Redwood Hwy & Shiloh Road

General Plan 2040 Project Altern. C Conditions

Timing Plan: Saturday Midday Peak

Lane Group	EBL	EBT	EBR	WBL	WBT	WBR	NBL	NBT	NBR	SBL	SBT	SBR
Turn Type	Split	NA	Perm	Split	NA	Perm	Prot	NA	Perm	Prot	NA	Perm
Protected Phases	2	2		6	6		3	8		7	4	
Permitted Phases			2			6			8			4
Detector Phase	2	2	2	6	6	6	3	8	8	7	4	4
Switch Phase												
Minimum Initial (s)	5.0	5.0	5.0	5.0	5.0	5.0	5.0	5.0	5.0	5.0	5.0	5.0
Minimum Split (s)	34.5	34.5	34.5	42.5	42.5	42.5	9.0	46.5	46.5	9.0	39.5	39.5
Total Split (s)	35.0	35.0	35.0	42.5	42.5	42.5	18.0	48.0	48.0	9.5	39.5	39.5
Total Split (%)	25.9%	25.9%	25.9%	31.5%	31.5%	31.5%	13.3%	35.6%	35.6%	7.0%	29.3%	29.3%
Maximum Green (s)	30.5	30.5	30.5	38.0	38.0	38.0	14.0	43.5	43.5	5.5	35.0	35.0
Yellow Time (s)	3.5	3.5	3.5	3.5	3.5	3.5	3.5	3.5	3.5	3.5	3.5	3.5
All-Red Time (s)	1.0	1.0	1.0	1.0	1.0	1.0	0.5	1.0	1.0	0.5	1.0	1.0
Lost Time Adjust (s)	0.0	0.0	0.0		0.0	0.0	0.0	0.0	0.0	0.0	0.0	0.0
Total Lost Time (s)	4.5	4.5	4.5		4.5	4.5	4.0	4.5	4.5	4.0	4.5	4.5
Lead/Lag	Lead	Lead	Lead	Lag	Lag	Lag	Lead	Lag	Lag	Lead	Lag	Lag
Lead-Lag Optimize?	Yes	Yes	Yes	Yes	Yes	Yes	Yes	Yes	Yes	Yes	Yes	Yes
Vehicle Extension (s)	3.0	3.0	3.0	3.0	3.0	3.0	3.0	3.0	3.0	3.0	3.0	3.0
Recall Mode	None	None	None	None	None	None	None	None	None	None	None	None
Walk Time (s)	7.0	7.0	7.0	7.0	7.0	7.0		7.0	7.0		7.0	7.0
Flash Don't Walk (s)	23.0	23.0	23.0	31.0	31.0	31.0		35.0	35.0		28.0	28.0
Pedestrian Calls (#/hr)	0	0	0	0	0	0		0	0		0	0
Act Effct Green (s)	19.2	19.2	19.2		21.4	21.4	14.7	33.7	33.7	5.8	22.1	22.1
Actuated g/C Ratio	0.20	0.20	0.20		0.22	0.22	0.15	0.35	0.35	0.06	0.23	0.23
v/c Ratio	0.58	0.63	0.52		0.71	0.10	0.98	0.56	0.06	0.45	0.71	0.61
Control Delay (s/veh)	44.0	45.4	9.4		46.5	0.4	95.4	32.5	0.2	65.1	45.3	21.4
Queue Delay	0.0	0.0	0.0		0.0	0.0	0.0	0.0	0.0	0.0	0.0	0.0
Total Delay (s/veh)	44.0	45.4	9.4		46.5	0.4	95.4	32.5	0.2	65.1	45.3	21.4
LOS	D	D	A		D	A	F	C	A	E	D	C
Approach Delay (s/veh)		31.3			40.7			55.6			35.9	
Approach LOS		C			D			E			D	

Intersection Summary

Area Type: Other  
 Cycle Length: 135  
 Actuated Cycle Length: 95.8  
 Natural Cycle: 135  
 Control Type: Actuated-Uncoordinated  
 Maximum v/c Ratio: 0.98  
 Intersection Signal Delay (s/veh): 40.8  
 Intersection LOS: D  
 Intersection Capacity Utilization 67.2%  
 ICU Level of Service C  
 Analysis Period (min) 15



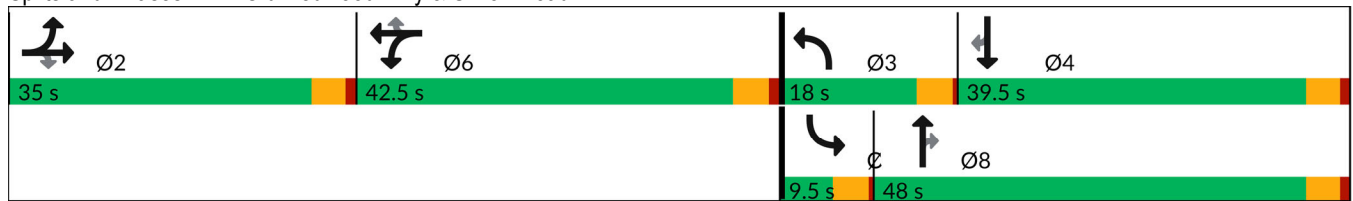

















Splits and Phases: 1: Old Redwood Hwy & Shiloh Road



Lanes, Volumes, Timings  
2: Shiloh Road & Hembree Ln

General Plan 2040 Project Altern. C Conditions

Timing Plan: Saturday Midday Peak

												
Lane Group	EBL	EBT	EBR	WBL	WBT	WBR	NBL	NBT	NBR	SBL	SBT	SBR
Lane Configurations												
Traffic Volume (vph)	918	500	69	110	442	235	111	21	128	236	11	856
Future Volume (vph)	918	500	69	110	442	235	111	21	128	236	11	856
Ideal Flow (vphpl)	1900	1900	1900	1900	1900	1900	1900	1900	1900	1900	1900	1900
Storage Length (ft)	0		0	100		130	0		0	0		0
Storage Lanes	2		0	1		1	1		0	0		1
Taper Length (ft)	25			50			25			25		
Lane Util. Factor	0.97	1.00	1.00	1.00	0.95	0.95	1.00	1.00	1.00	1.00	1.00	1.00
Ped Bike Factor	1.00				1.00							
Frt		0.983			0.948			0.871				0.850
Flt Protected	0.950			0.950			0.950				0.954	
Satd. Flow (prot)	3433	1831	0	1770	3340	0	1770	1622	0	0	1777	1583
Flt Permitted	0.950			0.950			0.950				0.954	
Satd. Flow (perm)	3432	1831	0	1770	3340	0	1770	1622	0	0	1777	1583
Right Turn on Red			Yes			Yes			Yes			Yes
Satd. Flow (RTOR)		13			144			128				274
Link Speed (mph)		40			40			30				35
Link Distance (ft)		302			1789			216				381
Travel Time (s)		5.1			30.5			4.9				7.4
Confl. Peds. (#/hr)	1						1					
Peak Hour Factor	0.94	0.94	1.00	1.00	0.96	0.96	1.00	1.00	1.00	0.91	1.00	0.91
Adj. Flow (vph)	977	532	69	110	460	245	111	21	128	259	11	941
Shared Lane Traffic (%)												
Lane Group Flow (vph)	977	601	0	110	705	0	111	149	0	0	270	941
Enter Blocked Intersection	No	No	No	No	No	No	No	No	No	No	No	No
Lane Alignment	Left	Left	Right	Left	Left	Right	Left	Left	Right	Left	Left	Right
Median Width(ft)		24			24			12				12
Link Offset(ft)		0			0			0				0
Crosswalk Width(ft)		16			16			16				16
Two way Left Turn Lane												
Headway Factor	1.00	1.00	1.00	1.00	1.00	1.00	1.00	1.00	1.00	1.00	1.00	1.00
Turning Speed (mph)	15		9	15		9	15		9	15		9
Number of Detectors	1	2		1	2		1	2		1	2	1
Detector Template	Left	Thru		Left	Thru		Left	Thru		Left	Thru	Right
Leading Detector (ft)	20	100		20	100		20	100		20	100	20
Trailing Detector (ft)	0	0		0	0		0	0		0	0	0
Detector 1 Position(ft)	0	0		0	0		0	0		0	0	0
Detector 1 Size(ft)	20	6		20	6		20	6		20	6	20
Detector 1 Type	Cl+Ex	Cl+Ex		Cl+Ex	Cl+Ex		Cl+Ex	Cl+Ex		Cl+Ex	Cl+Ex	Cl+Ex
Detector 1 Channel												
Detector 1 Extend (s)	0.0	0.0		0.0	0.0		0.0	0.0		0.0	0.0	0.0
Detector 1 Queue (s)	0.0	0.0		0.0	0.0		0.0	0.0		0.0	0.0	0.0
Detector 1 Delay (s)	0.0	0.0		0.0	0.0		0.0	0.0		0.0	0.0	0.0
Detector 2 Position(ft)		94			94			94				94
Detector 2 Size(ft)		6			6			6				6
Detector 2 Type		Cl+Ex			Cl+Ex			Cl+Ex				Cl+Ex
Detector 2 Channel												
Detector 2 Extend (s)		0.0			0.0			0.0				0.0
Turn Type	Prot	NA		Prot	NA		Split	NA		Split	NA	pt+ov

Lanes, Volumes, Timings  
2: Shiloh Road & Hembree Ln

General Plan 2040 Project Altern. C Conditions  
Timing Plan: Saturday Midday Peak

Lane Group	EBL	EBT	EBR	WBL	WBT	WBR	NBL	NBT	NBR	SBL	SBT	SBR
Protected Phases	5	2		1	6		8	8		4	4	4 5
Permitted Phases												
Detector Phase	5	2		1	6		8	8		4	4	4 5
Switch Phase												
Minimum Initial (s)	3.0	5.0		5.0	5.0		5.0	5.0		5.0	5.0	
Minimum Split (s)	7.5	9.5		9.5	43.5		9.5	9.5		9.5	9.5	
Total Split (s)	21.0	57.0		9.5	45.5		9.5	9.5		14.0	14.0	
Total Split (%)	23.3%	63.3%		10.6%	50.6%		10.6%	10.6%		15.6%	15.6%	
Maximum Green (s)	17.0	53.0		5.5	41.5		5.5	5.5		10.0	10.0	
Yellow Time (s)	3.0	3.0		3.0	3.0		3.0	3.0		3.0	3.0	
All-Red Time (s)	1.0	1.0		1.0	1.0		1.0	1.0		1.0	1.0	
Lost Time Adjust (s)	0.0	0.0		0.0	0.0		0.0	0.0		0.0	0.0	
Total Lost Time (s)	4.0	4.0		4.0	4.0		4.0	4.0		4.0	4.0	
Lead/Lag	Lead	Lag		Lead	Lag							
Lead-Lag Optimize?	Yes	Yes		Yes	Yes							
Vehicle Extension (s)	3.0	3.0		3.0	3.0		3.0	3.0		3.0	3.0	
Recall Mode	None	None		None	None		None	None		None	None	
Walk Time (s)					7.0							
Flash Don't Walk (s)					32.0							
Pedestrian Calls (#/hr)					1							
Act Effct Green (s)	17.3	31.6		5.6	19.9		5.6	5.6		10.2	27.4	
Actuated g/C Ratio	0.25	0.46		0.08	0.29		0.08	0.08		0.15	0.40	
v/c Ratio	1.14	0.71		0.77	0.66		0.78	0.60		1.03	1.19	
Control Delay (s/veh)	105.0	19.6		70.1	19.5		71.1	21.6		100.0	113.2	
Queue Delay	0.0	0.0		0.0	0.0		0.0	0.0		0.0	0.0	
Total Delay (s/veh)	105.0	19.6		70.1	19.5		71.1	21.6		100.0	113.2	
LOS	F	B		E	B		E	C		F	F	
Approach Delay (s/veh)		72.5			26.3			42.7			110.3	
Approach LOS		E			C			D			F	

Intersection Summary

Area Type:	Other
Cycle Length:	90
Actuated Cycle Length:	69.2
Natural Cycle:	150
Control Type:	Actuated-Uncoordinated
Maximum v/c Ratio:	1.19
Intersection Signal Delay (s/veh):	72.6
Intersection LOS:	E
Intersection Capacity Utilization:	92.2%
ICU Level of Service:	F
Analysis Period (min):	15

Splits and Phases: 2: Shiloh Road & Hembree Ln





Lanes, Volumes, Timings  
3: US 101 NB Off-Ramp & Shiloh Road

General Plan 2040 Project Altern. C Conditions  
Timing Plan: Saturday Midday Peak

	→	↘	↙	←	↖	↗
Lane Group	EBT	EBR	WBL	WBT	NBL	NBR
Lane Configurations	↑↑			↑	↘	↗
Traffic Volume (vph)	574	0	0	997	520	842
Future Volume (vph)	574	0	0	997	520	842
Ideal Flow (vphpl)	1900	1900	1900	1900	1900	1900
Storage Length (ft)		0	0		0	265
Storage Lanes		0	0		1	2
Taper Length (ft)			25		25	
Lane Util. Factor	0.95	1.00	1.00	1.00	1.00	0.88
Ped Bike Factor						
Frt						0.850
Flt Protected					0.950	
Satd. Flow (prot)	3539	0	0	1863	1770	2787
Flt Permitted					0.950	
Satd. Flow (perm)	3539	0	0	1863	1770	2787
Right Turn on Red		Yes				Yes
Satd. Flow (RTOR)						307
Link Speed (mph)	40			40	30	
Link Distance (ft)	186			371	769	
Travel Time (s)	3.2			6.3	17.5	
Confl. Bikes (#/hr)		1				
Peak Hour Factor	0.91	0.91	0.89	0.89	0.95	0.95
Adj. Flow (vph)	631	0	0	1120	547	886
Shared Lane Traffic (%)						
Lane Group Flow (vph)	631	0	0	1120	547	886
Enter Blocked Intersection	No	No	No	No	No	No
Lane Alignment	Left	Right	Left	Left	Left	Right
Median Width(ft)	0			0	12	
Link Offset(ft)	0			0	0	
Crosswalk Width(ft)	16			16	16	
Two way Left Turn Lane						
Headway Factor	1.00	1.00	1.00	1.00	1.00	1.00
Turning Speed (mph)		9	15		15	9
Number of Detectors	2			2	1	1
Detector Template	Thru			Thru	Left	Right
Leading Detector (ft)	100			100	20	20
Trailing Detector (ft)	0			0	0	0
Detector 1 Position(ft)	0			0	0	0
Detector 1 Size(ft)	6			6	20	20
Detector 1 Type	Cl+Ex			Cl+Ex	Cl+Ex	Cl+Ex
Detector 1 Channel						
Detector 1 Extend (s)	0.0			0.0	0.0	0.0
Detector 1 Queue (s)	0.0			0.0	0.0	0.0
Detector 1 Delay (s)	0.0			0.0	0.0	0.0
Detector 2 Position(ft)	94			94		
Detector 2 Size(ft)	6			6		
Detector 2 Type	Cl+Ex			Cl+Ex		
Detector 2 Channel						
Detector 2 Extend (s)	0.0			0.0		
Turn Type	NA			NA	Prot	Perm

Lanes, Volumes, Timings  
 3: US 101 NB Off-Ramp & Shiloh Road

General Plan 2040 Project Altern. C Conditions  
 Timing Plan: Saturday Midday Peak



Lane Group	EBT	EBR	WBL	WBT	NBL	NBR
Protected Phases	2			6	8	
Permitted Phases						8
Detector Phase	2			6	8	8
Switch Phase						
Minimum Initial (s)	5.0			5.0	5.0	5.0
Minimum Split (s)	9.5			9.5	9.5	9.5
Total Split (s)	37.0			37.0	35.0	35.0
Total Split (%)	51.4%			51.4%	48.6%	48.6%
Maximum Green (s)	32.5			32.5	30.5	30.5
Yellow Time (s)	3.5			3.5	3.5	3.5
All-Red Time (s)	1.0			1.0	1.0	1.0
Lost Time Adjust (s)	0.0			0.0	0.0	0.0
Total Lost Time (s)	4.5			4.5	4.5	4.5
Lead/Lag						
Lead-Lag Optimize?						
Vehicle Extension (s)	3.0			3.0	3.0	3.0
Recall Mode	None			None	None	None
Act Effct Green (s)	32.7			32.7	25.9	25.9
Actuated g/C Ratio	0.48			0.48	0.38	0.38
v/c Ratio	0.37			1.25	0.81	0.70
Control Delay (s/veh)	12.7			141.6	28.9	14.3
Queue Delay	0.0			0.0	0.0	0.0
Total Delay (s/veh)	12.7			141.6	28.9	14.3
LOS	B			F	C	B
Approach Delay (s/veh)	12.7			141.6	19.9	
Approach LOS	B			F	B	

Intersection Summary

Area Type:	Other
Cycle Length:	72
Actuated Cycle Length:	67.7
Natural Cycle:	100
Control Type:	Actuated-Uncoordinated
Maximum v/c Ratio:	1.25
Intersection Signal Delay (s/veh):	61.3
Intersection LOS:	E
Intersection Capacity Utilization:	132.5%
ICU Level of Service:	H
Analysis Period (min):	15

Splits and Phases: 3: US 101 NB Off-Ramp & Shiloh Road

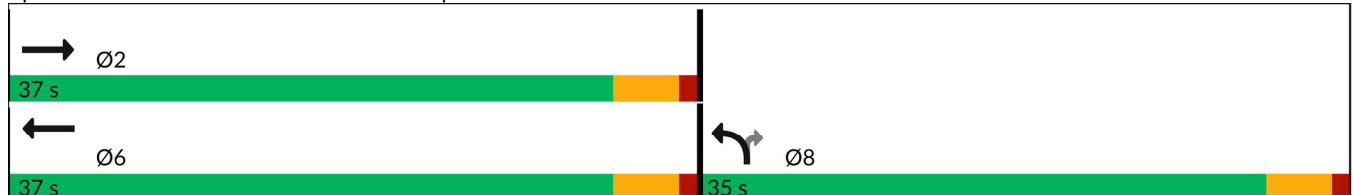

Lanes, Volumes, Timings  
4: Shiloh Road & US 101 SB Off-Ramp

General Plan 2040 Project Altern. C Conditions  
Timing Plan: Saturday Midday Peak

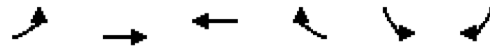

Lane Group	EBL	EBT	WBT	WBR	SBL	SBR
Lane Configurations		↑	↑		↓	↓
Traffic Volume (vph)	0	399	770	0	291	223
Future Volume (vph)	0	399	770	0	291	223
Ideal Flow (vphp)	1900	1900	1900	1900	1900	1900
Storage Length (ft)	0			0	0	275
Storage Lanes	0			0	1	1
Taper Length (ft)	25				25	
Lane Util. Factor	1.00	1.00	1.00	1.00	1.00	1.00
Ped Bike Factor						
Frt						0.850
Flt Protected					0.950	
Satd. Flow (prot)	0	1863	1863	0	1770	1583
Flt Permitted					0.950	
Satd. Flow (perm)	0	1863	1863	0	1770	1583
Right Turn on Red				Yes		Yes
Satd. Flow (RTOR)						254
Link Speed (mph)		40	40		30	
Link Distance (ft)		225	306		486	
Travel Time (s)		3.8	5.2		11.0	
Confl. Bikes (#/hr)				2		
Peak Hour Factor	0.96	0.96	0.96	0.96	0.68	0.68
Adj. Flow (vph)	0	416	802	0	428	328
Shared Lane Traffic (%)						
Lane Group Flow (vph)	0	416	802	0	428	328
Enter Blocked Intersection	No	No	No	No	No	No
Lane Alignment	Left	Left	Left	Right	Left	Right
Median Width(ft)		4	0		12	
Link Offset(ft)		0	0		0	
Crosswalk Width(ft)		16	16		16	
Two way Left Turn Lane						
Headway Factor	1.00	1.00	1.00	1.00	1.00	1.00
Turning Speed (mph)	15			9	15	9
Number of Detectors		2	2		1	1
Detector Template		Thru	Thru		Left	Right
Leading Detector (ft)		100	100		20	20
Trailing Detector (ft)		0	0		0	0
Detector 1 Position(ft)		0	0		0	0
Detector 1 Size(ft)		6	6		20	20
Detector 1 Type		Cl+Ex	Cl+Ex		Cl+Ex	Cl+Ex
Detector 1 Channel						
Detector 1 Extend (s)		0.0	0.0		0.0	0.0
Detector 1 Queue (s)		0.0	0.0		0.0	0.0
Detector 1 Delay (s)		0.0	0.0		0.0	0.0
Detector 2 Position(ft)		94	94			
Detector 2 Size(ft)		6	6			
Detector 2 Type		Cl+Ex	Cl+Ex			
Detector 2 Channel						
Detector 2 Extend (s)		0.0	0.0			
Turn Type		NA	NA		Perm	Perm

Lanes, Volumes, Timings  
4: Shiloh Road & US 101 SB Off-Ramp

General Plan 2040 Project Altern. C Conditions  
Timing Plan: Saturday Midday Peak



Lane Group	EBL	EBT	WBT	WBR	SBL	SBR
Protected Phases		2	6			
Permitted Phases					4	4
Detector Phase		2	6		4	4
Switch Phase						
Minimum Initial (s)		5.0	5.0		5.0	5.0
Minimum Split (s)		9.5	38.5		9.5	9.5
Total Split (s)		69.0	69.0		21.0	21.0
Total Split (%)		76.7%	76.7%		23.3%	23.3%
Maximum Green (s)		64.5	64.5		16.5	16.5
Yellow Time (s)		3.5	3.5		3.5	3.5
All-Red Time (s)		1.0	1.0		1.0	1.0
Lost Time Adjust (s)		0.0	0.0		0.0	0.0
Total Lost Time (s)		4.5	4.5		4.5	4.5
Lead/Lag						
Lead-Lag Optimize?						
Vehicle Extension (s)		3.0	3.0		3.0	3.0
Recall Mode		None	None		None	None
Walk Time (s)			7.0			
Flash Don't Walk (s)			27.0			
Pedestrian Calls (#/hr)			0			
Act Effct Green (s)		29.3	29.3		16.9	16.9
Actuated g/C Ratio		0.53	0.53		0.31	0.31
v/c Ratio		0.42	0.82		0.79	0.50
Control Delay (s/veh)		8.8	17.9		34.9	8.7
Queue Delay		0.0	0.0		0.0	0.0
Total Delay (s/veh)		8.8	17.9		34.9	8.7
LOS		A	B		C	A
Approach Delay (s/veh)		8.8	17.9		23.5	
Approach LOS		A	B		C	

Intersection Summary

Area Type:	Other
Cycle Length:	90
Actuated Cycle Length:	55.4
Natural Cycle:	60
Control Type:	Actuated-Uncoordinated
Maximum v/c Ratio:	0.82
Intersection Signal Delay (s/veh):	18.2
Intersection LOS:	B
Intersection Capacity Utilization:	133.4%
ICU Level of Service:	H
Analysis Period (min):	15

Splits and Phases: 4: Shiloh Road & US 101 SB Off-Ramp

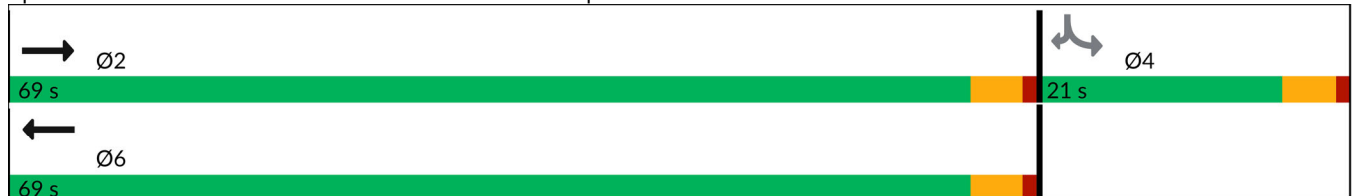

Lanes, Volumes, Timings  
5: Caletti Ave & Shiloh Road

General Plan 2040 Project Altern. C Conditions

Timing Plan: Saturday Midday Peak



















	→	↘	↙	←	↖	↗
Lane Group	EBT	EBR	WBL	WBT	NBL	NBR
Lane Configurations	↑↑		↘	↑	↘	↗
Traffic Volume (vph)	801	30	120	887	24	115
Future Volume (vph)	801	30	120	887	24	115
Ideal Flow (vphp)	1900	1900	1900	1900	1900	1900
Storage Length (ft)		0	68		0	0
Storage Lanes		0	1		1	1
Taper Length (ft)			50		25	
Lane Util. Factor	0.95	0.95	1.00	1.00	1.00	1.00
Ped Bike Factor						
Frt	0.995					0.850
Flt Protected			0.950		0.950	
Satd. Flow (prot)	3522	0	1770	1863	1770	1583
Flt Permitted			0.950		0.950	
Satd. Flow (perm)	3522	0	1770	1863	1770	1583
Link Speed (mph)	40			40	30	
Link Distance (ft)	1081			184	459	
Travel Time (s)	18.4			3.1	10.4	
Confl. Peds. (#/hr)					1	
Confl. Bikes (#/hr)		1				
Peak Hour Factor	0.92	0.92	0.87	0.87	0.78	0.78
Adj. Flow (vph)	871	33	138	1020	31	147
Shared Lane Traffic (%)						
Lane Group Flow (vph)	904	0	138	1020	31	147
Enter Blocked Intersection	No	No	No	No	No	No
Lane Alignment	Left	Right	Left	Left	Left	Right
Median Width(ft)	12			12	12	
Link Offset(ft)	0			0	0	
Crosswalk Width(ft)	16			16	16	
Two way Left Turn Lane						
Headway Factor	1.00	1.00	1.00	1.00	1.00	1.00
Turning Speed (mph)		9	15		15	9
Sign Control	Free			Free	Stop	

Intersection Summary

Area Type:	Other
Control Type:	Unsignalized
Intersection Capacity Utilization	56.7%
Analysis Period (min)	15
	ICU Level of Service B

Lanes, Volumes, Timings  
6: Conde Lane & Shiloh Road

General Plan 2040 Project Altern. C Conditions  
Timing Plan: Saturday Midday Peak

												
Lane Group	EBL	EBT	EBR	WBL	WBT	WBR	NBL	NBT	NBR	SBL	SBT	SBR
Lane Configurations												
Traffic Volume (vph)	43	529	1	13	590	301	1	0	9	291	0	41
Future Volume (vph)	43	529	1	13	590	301	1	0	9	291	0	41
Ideal Flow (vphpl)	1900	1900	1900	1900	1900	1900	1900	1900	1900	1900	1900	1900
Storage Length (ft)	90		0	127		0	0		0	0		40
Storage Lanes	1		0	1		0	0		0	0		1
Taper Length (ft)	70			40			25			25		
Lane Util. Factor	1.00	0.95	0.95	1.00	0.95	0.95	1.00	1.00	1.00	1.00	1.00	1.00
Ped Bike Factor					0.99							
Frt					0.949			0.880				0.850
Flt Protected	0.950			0.950				0.994			0.950	
Satd. Flow (prot)	1770	3539	0	1770	3334	0	0	1629	0	0	1770	1583
Flt Permitted	0.950			0.950				0.994			0.950	
Satd. Flow (perm)	1770	3539	0	1770	3334	0	0	1629	0	0	1770	1583
Right Turn on Red			Yes			Yes			Yes			No
Satd. Flow (RTOR)					92			102				
Link Speed (mph)		40			40			30				35
Link Distance (ft)		815			1081			418				522
Travel Time (s)		13.9			18.4			9.5				10.2
Confl. Bikes (#/hr)						2						
Peak Hour Factor	0.96	0.96	0.96	0.91	0.91	0.91	0.58	0.58	0.58	0.78	0.78	0.78
Adj. Flow (vph)	45	551	1	14	648	331	2	0	16	373	0	53
Shared Lane Traffic (%)												
Lane Group Flow (vph)	45	552	0	14	979	0	0	18	0	0	373	53
Enter Blocked Intersection	No	No	No	No	No	No	No	No	No	No	No	No
Lane Alignment	Left	Left	Right	Left	Left	Right	Left	Left	Right	Left	Left	Right
Median Width(ft)		12			12			0				0
Link Offset(ft)		0			0			0				0
Crosswalk Width(ft)		16			16			16				16
Two way Left Turn Lane												
Headway Factor	1.00	1.00	1.00	1.00	1.00	1.00	1.00	1.00	1.00	1.00	1.00	1.00
Turning Speed (mph)	15		9	15		9	15		9	15		9
Number of Detectors	1	2		1	2		1	2		1	1	1
Detector Template	Left	Thru		Left	Thru		Left	Thru		Left	Thru	Right
Leading Detector (ft)	20	100		20	100		20	100		20	30	20
Trailing Detector (ft)	0	0		0	0		0	0		0	0	0
Detector 1 Position(ft)	0	0		0	0		0	0		0	0	0
Detector 1 Size(ft)	20	6		20	6		20	6		20	30	20
Detector 1 Type	Cl+Ex	Cl+Ex		Cl+Ex	Cl+Ex		Cl+Ex	Cl+Ex		Cl+Ex	Cl+Ex	Cl+Ex
Detector 1 Channel												
Detector 1 Extend (s)	0.0	0.0		0.0	0.0		0.0	0.0		0.0	0.0	0.0
Detector 1 Queue (s)	0.0	0.0		0.0	0.0		0.0	0.0		0.0	0.0	0.0
Detector 1 Delay (s)	0.0	0.0		0.0	0.0		0.0	0.0		0.0	0.0	0.0
Detector 2 Position(ft)		94			94			94				
Detector 2 Size(ft)		6			6			6				
Detector 2 Type		Cl+Ex			Cl+Ex			Cl+Ex				
Detector 2 Channel												
Detector 2 Extend (s)		0.0			0.0			0.0				
Turn Type	Prot	NA		Prot	NA		Split	NA		Split	NA	custom

Lanes, Volumes, Timings  
6: Conde Lane & Shiloh Road

General Plan 2040 Project Altern. C Conditions  
Timing Plan: Saturday Midday Peak

Lane Group	EBL	EBT	EBR	WBL	WBT	WBR	NBL	NBT	NBR	SBL	SBT	SBR
Protected Phases	5	2		1	6		7	7		4	4	
Permitted Phases												6
Detector Phase	5	2		1	6		7	7		4	4	6
Switch Phase												
Minimum Initial (s)	8.0	8.0		8.0	8.0		10.0	10.0		11.0	11.0	8.0
Minimum Split (s)	12.5	46.5		12.5	12.5		37.5	37.5		15.5	15.5	12.5
Total Split (s)	13.0	46.5		12.5	45.0		37.5	37.5		15.5	15.5	45.0
Total Split (%)	11.6%	41.5%		11.2%	40.2%		33.5%	33.5%		13.8%	13.8%	40.2%
Maximum Green (s)	8.5	42.0		8.0	40.5		33.0	33.0		11.0	11.0	40.5
Yellow Time (s)	3.5	3.5		3.5	3.5		3.5	3.5		3.5	3.5	3.5
All-Red Time (s)	1.0	1.0		1.0	1.0		1.0	1.0		1.0	1.0	1.0
Lost Time Adjust (s)	0.0	0.0		0.0	0.0		0.0	0.0		0.0	0.0	0.0
Total Lost Time (s)	4.5	4.5		4.5	4.5		4.5	4.5		4.5	4.5	4.5
Lead/Lag	Lead	Lag		Lead	Lag							Lag
Lead-Lag Optimize?	Yes	Yes		Yes	Yes							Yes
Vehicle Extension (s)	3.0	3.0		3.0	3.0		3.0	3.0		3.0	3.0	3.0
Recall Mode	None	None		None	None		None	None		None	None	None
Walk Time (s)		7.0					7.0	7.0				
Flash Don't Walk (s)		35.0					26.0	26.0				
Pedestrian Calls (#/hr)		0					0	0				
Act Effct Green (s)	9.3	29.9		9.2	25.2		11.4	11.4		12.6	12.6	25.2
Actuated g/C Ratio	0.16	0.51		0.16	0.43		0.19	0.19		0.22	0.22	0.43
v/c Ratio	0.16	0.31		0.05	0.66		0.05	0.05		0.98	0.98	0.08
Control Delay (s/veh)	32.3	9.8		32.7	15.8		0.2	0.2		76.2	76.2	13.2
Queue Delay	0.0	0.0		0.0	0.0		0.0	0.0		0.0	0.0	0.0
Total Delay (s/veh)	32.3	9.8		32.7	15.8		0.2	0.2		76.2	76.2	13.2
LOS	C	A		C	B		A	A		E	E	B
Approach Delay (s/veh)		11.5			16.1		0.2	0.2		68.4	68.4	
Approach LOS		B			B		A	A		E	E	

**Intersection Summary**

Area Type: Other

Cycle Length: 112

Actuated Cycle Length: 58.6

Natural Cycle: 125

Control Type: Actuated-Uncoordinated

Maximum v/c Ratio: 0.98

Intersection Signal Delay (s/veh): 25.5      Intersection LOS: C

Intersection Capacity Utilization 66.0%      ICU Level of Service C





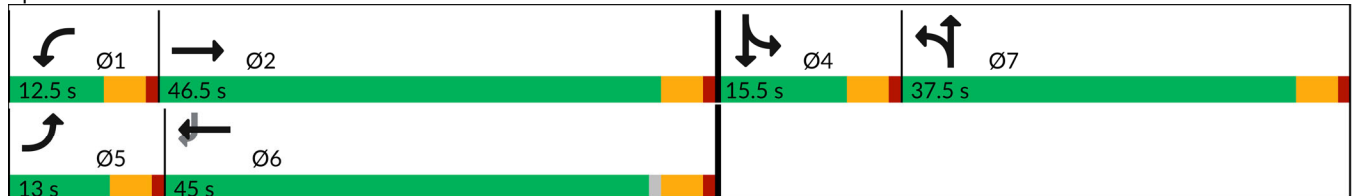











Analysis Period (min) 15

Splits and Phases: 6: Conde Lane & Shiloh Road



Lanes, Volumes, Timings  
7: Entrance 1/Gridley Drive & Shiloh Road



















General Plan 2040 Project Altern. C Conditions  
Timing Plan: Saturday Midday Peak

												
Lane Group	EBL	EBT	EBR	WBL	WBT	WBR	NBL	NBT	NBR	SBL	SBT	SBR
Lane Configurations												
Traffic Volume (vph)	30	157	118	8	135	0	133	0	9	0	0	27
Future Volume (vph)	30	157	118	8	135	0	133	0	9	0	0	27
Ideal Flow (vphpl)	1900	1900	1900	1900	1900	1900	1900	1900	1900	1900	1900	1900
Lane Util. Factor	1.00	1.00	1.00	1.00	1.00	1.00	1.00	1.00	1.00	1.00	1.00	1.00
Ped Bike Factor												
Frt		0.948						0.850			0.865	
Flt Protected		0.995			0.997		0.950					
Satd. Flow (prot)	0	1757	0	0	1857	0	1770	1583	0	0	1611	0
Flt Permitted		0.995			0.997		0.950					
Satd. Flow (perm)	0	1757	0	0	1857	0	1770	1583	0	0	1611	0
Link Speed (mph)		40			40			30			30	
Link Distance (ft)		608			2146			248			715	
Travel Time (s)		10.4			36.6			5.6			16.3	
Confl. Peds. (#/hr)	1											
Confl. Bikes (#/hr)			1			3						
Peak Hour Factor	0.93	0.93	0.93	0.88	0.88	0.88	1.00	1.00	1.00	0.56	0.56	0.56
Adj. Flow (vph)	32	169	127	9	153	0	133	0	9	0	0	48
Shared Lane Traffic (%)												
Lane Group Flow (vph)	0	328	0	0	162	0	133	9	0	0	48	0
Enter Blocked Intersection	No	No	No	No	No	No	No	No	No	No	No	No
Lane Alignment	Left	Left	Right	Left	Left	Right	Left	Left	Right	Left	Left	Right
Median Width(ft)		0			0			12			12	
Link Offset(ft)		0			0			0			0	
Crosswalk Width(ft)		16			16			16			16	
Two way Left Turn Lane												
Headway Factor	1.00	1.00	1.00	1.00	1.00	1.00	1.00	1.00	1.00	1.00	1.00	1.00
Turning Speed (mph)	15		9	15		9	15		9	15		9
Sign Control		Free			Free			Stop			Stop	
<b>Intersection Summary</b>												
Area Type:	Other											
Control Type:	Unsignalized											
Intersection Capacity Utilization	46.6%						ICU Level of Service A					
Analysis Period (min)	15											



Lanes, Volumes, Timings  
8: Old Redwood Hwy & Entrance 1

General Plan 2040 Project Altern. C Conditions  
Timing Plan: Saturday Midday Peak

												
Lane Group	EBL	EBT	EBR	WBL	WBT	WBR	NBL	NBT	NBR	SBL	SBT	SBR
Lane Configurations												
Traffic Volume (vph)	1	0	3	19	0	30	1	595	17	27	505	6
Future Volume (vph)	1	0	3	19	0	30	1	595	17	27	505	6
Ideal Flow (vphp)	1900	1900	1900	1900	1900	1900	1900	1900	1900	1900	1900	1900
Storage Length (ft)	0		0	0		0	0		0	50		0
Storage Lanes	0		0	1		0	0		0	1		0
Taper Length (ft)	25			25			25			25		
Lane Util. Factor	1.00	1.00	1.00	1.00	1.00	1.00	1.00	1.00	1.00	1.00	1.00	1.00
Ped Bike Factor												
Frt		0.902			0.850			0.996				0.998
Flt Protected		0.987		0.950						0.950		
Satd. Flow (prot)	0	1658	0	1770	1583	0	0	1855	0	1770	1859	0
Flt Permitted		0.987		0.950						0.950		
Satd. Flow (perm)	0	1658	0	1770	1583	0	0	1855	0	1770	1859	0
Link Speed (mph)		30			30			45			45	
Link Distance (ft)		98			385			520			748	
Travel Time (s)		2.2			8.8			7.9			11.3	
Confl. Peds. (#/hr)							1		4	4		1
Confl. Bikes (#/hr)									3			9
Peak Hour Factor	0.38	0.38	0.38	1.00	1.00	1.00	0.94	0.94	0.94	0.93	0.93	0.93
Adj. Flow (vph)	3	0	8	19	0	30	1	633	18	29	543	6
Shared Lane Traffic (%)												
Lane Group Flow (vph)	0	11	0	19	30	0	0	652	0	29	549	0
Enter Blocked Intersection	No	No	No	No	No	No	No	No	No	No	No	No
Lane Alignment	Left	Left	Right	Left	Left	Right	Left	Left	Right	Left	Left	Right
Median Width(ft)		12			12			12			12	
Link Offset(ft)		0			0			0			0	
Crosswalk Width(ft)		16			16			16			16	
Two way Left Turn Lane												
Headway Factor	1.00	1.00	1.00	1.00	1.00	1.00	1.00	1.00	1.00	1.00	1.00	1.00
Turning Speed (mph)	15		9	15		9	15		9	15		9
Sign Control		Stop			Stop			Free			Free	
<b>Intersection Summary</b>												
Area Type:	Other											
Control Type:	Unsignalized											
Intersection Capacity Utilization	43.2%						ICU Level of Service A					
Analysis Period (min)	15											

Lanes, Volumes, Timings  
9: Entrance 2 & Shiloh Road

General Plan 2040 Project Altern. C Conditions  
Timing Plan: Saturday Midday Peak

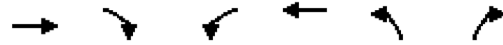

Lane Group	EBT	EBR	WBL	WBT	NBL	NBR
Lane Configurations	→			←	↔	↔
Traffic Volume (vph)	145	0	0	135	0	0
Future Volume (vph)	145	0	0	135	0	0
Ideal Flow (vphpl)	1900	1900	1900	1900	1900	1900
Lane Util. Factor	1.00	1.00	1.00	1.00	1.00	1.00
Ped Bike Factor						
Frt						
Flt Protected						
Satd. Flow (prot)	1863	0	0	1863	1863	1863
Flt Permitted						
Satd. Flow (perm)	1863	0	0	1863	1863	1863
Link Speed (mph)	40			40	30	
Link Distance (ft)	2146			134	402	
Travel Time (s)	36.6			2.3	9.1	
Confl. Peds. (#/hr)		1				
Peak Hour Factor	0.88	0.88	0.80	0.80	1.00	1.00
Adj. Flow (vph)	165	0	0	169	0	0
Shared Lane Traffic (%)						
Lane Group Flow (vph)	165	0	0	169	0	0
Enter Blocked Intersection	No	No	No	No	No	No
Lane Alignment	Left	Right	Left	Left	Left	Right
Median Width(ft)	0			0	12	
Link Offset(ft)	0			0	0	
Crosswalk Width(ft)	16			16	16	
Two way Left Turn Lane						
Headway Factor	1.00	1.00	1.00	1.00	1.00	1.00
Turning Speed (mph)		9	15		15	9
Sign Control	Free			Free	Stop	

Intersection Summary

Area Type:	Other
Control Type:	Unsignalized
Intersection Capacity Utilization	11.2%
Analysis Period (min)	15
	ICU Level of Service A

Lanes, Volumes, Timings

General Plan 2040 Project Altern. C Conditions

10: US 101 NB Off Ramp/Lakewood Drive & Old Redwood Highway Timing Plan: Saturday Midday Peak



Lane Group	EBL	EBT	EBR	WBL	WBT	WBR	NBL	NBT	NBR	SBL	SBT	SBR
Lane Configurations												
Traffic Volume (vph)	372	423	0	0	670	357	415	393	185	316	0	908
Future Volume (vph)	372	423	0	0	670	357	415	393	185	316	0	908
Ideal Flow (vphpl)	1900	1900	1900	1900	1900	1900	1900	1900	1900	1900	1900	1900
Storage Length (ft)	155		0	0		0	270		150	120		0
Storage Lanes	1		0	0		0	1		1	1		1
Taper Length (ft)	50			25			165			75		
Lane Util. Factor	0.97	1.00	1.00	1.00	0.95	0.95	0.91	0.91	0.95	0.97	1.00	1.00
Ped Bike Factor	1.00				0.99			1.00		1.00		
Fr <sub>t</sub>					0.948			0.958				0.850
Fl <sub>t</sub> Protected	0.950						0.950	0.994		0.950		
Satd. Flow (prot)	3433	1863	0	0	3336	0	1610	3217	0	3433	0	1583
Fl <sub>t</sub> Permitted	0.950						0.950	0.994		0.950		
Satd. Flow (perm)	3430	1863	0	0	3336	0	1610	3217	0	3431	0	1583
Right Turn on Red			Yes			Yes			Yes			Yes
Satd. Flow (RTOR)					114			61				249
Link Speed (mph)		35			35			30				30
Link Distance (ft)		226			617			716				478
Travel Time (s)		4.4			12.0			16.3				10.9
Confl. Peds. (#/hr)	2		1	1		2			1	1		
Confl. Bikes (#/hr)			10			3						
Peak Hour Factor	0.95	0.95	0.95	0.89	0.89	0.89	0.98	0.98	0.98	0.88	0.88	0.88
Adj. Flow (vph)	392	445	0	0	753	401	423	401	189	359	0	1032
Shared Lane Traffic (%)							20%					
Lane Group Flow (vph)	392	445	0	0	1154	0	338	675	0	359	0	1032
Enter Blocked Intersection	No	No	No	No	No	No	No	No	No	No	No	No
Lane Alignment	Left	Left	Right	Left	Left	Right	Left	Left	Right	Left	Left	Right
Median Width(ft)		24			24			24				24
Link Offset(ft)		0			0			0				0
Crosswalk Width(ft)		16			16			16				16
Two way Left Turn Lane												
Headway Factor	1.00	1.00	1.00	1.00	1.00	1.00	1.00	1.00	1.00	1.00	1.00	1.00
Turning Speed (mph)	15		9	15		9	15		9	15		9
Number of Detectors	1	2			2		1	2		1		1
Detector Template	Left	Thru			Thru		Left	Thru		Left		Right
Leading Detector (ft)	20	100			100		20	100		20		20
Trailing Detector (ft)	0	0			0		0	0		0		0
Detector 1 Position(ft)	0	0			0		0	0		0		0
Detector 1 Size(ft)	20	6			6		20	6		20		20
Detector 1 Type	Cl+Ex	Cl+Ex			Cl+Ex		Cl+Ex	Cl+Ex		Cl+Ex		Cl+Ex
Detector 1 Channel												
Detector 1 Extend (s)	0.0	0.0			0.0		0.0	0.0		0.0		0.0
Detector 1 Queue (s)	0.0	0.0			0.0		0.0	0.0		0.0		0.0
Detector 1 Delay (s)	0.0	0.0			0.0		0.0	0.0		0.0		0.0
Detector 2 Position(ft)		94			94			94				
Detector 2 Size(ft)		6			6			6				
Detector 2 Type		Cl+Ex			Cl+Ex			Cl+Ex				
Detector 2 Channel												
Detector 2 Extend (s)		0.0			0.0			0.0				

Lanes, Volumes, Timings

General Plan 2040 Project Altern. C Conditions

10: US 101 NB Off Ramp/Lakewood Drive & Old Redwood Highway Timing Plan: Saturday Midday Peak



Lane Group	EBL	EBT	EBR	WBL	WBT	WBR	NBL	NBT	NBR	SBL	SBT	SBR
Turn Type	Prot	NA			NA		Split	NA		Prot		pm+ov
Protected Phases	5	2			6		8	8		7		5
Permitted Phases												5 8
Detector Phase	5	2			6		8	8		7		5
Switch Phase												
Minimum Initial (s)	7.0	10.0			10.0		10.0	10.0		7.0		7.0
Minimum Split (s)	11.5	32.1			32.1		33.7	33.7		11.5		11.5
Total Split (s)	12.0	45.3			33.3		33.7	33.7		11.5		12.0
Total Split (%)	13.3%	50.1%			36.8%		37.2%	37.2%		12.7%		13.3%
Maximum Green (s)	7.5	40.8			28.8		29.2	29.2		7.0		7.5
Yellow Time (s)	3.5	3.5			3.5		3.5	3.5		3.5		3.5
All-Red Time (s)	1.0	1.0			1.0		1.0	1.0		1.0		1.0
Lost Time Adjust (s)	0.0	0.0			0.0		0.0	0.0		0.0		0.0
Total Lost Time (s)	4.5	4.5			4.5		4.5	4.5		4.5		4.5
Lead/Lag	Lead				Lag		Lag	Lag		Lead		Lead
Lead-Lag Optimize?	Yes				Yes		Yes	Yes		Yes		Yes
Vehicle Extension (s)	3.0	3.0			3.0		3.0	3.0		3.0		3.0
Recall Mode	None	Max			Max		None	None		None		None
Walk Time (s)		7.0			7.0		7.0	7.0				
Flash Don't Walk (s)		20.0			17.0		22.0	22.0				
Pedestrian Calls (#/hr)		0			0		0	0				
Act Effct Green (s)	7.5	41.0			28.9		24.7	24.7		7.0		36.7
Actuated g/C Ratio	0.09	0.48			0.34		0.29	0.29		0.08		0.43
v/c Ratio	1.31	0.50			0.97		0.73	0.70		1.29		1.26
Control Delay (s/veh)	195.7	19.0			46.5		37.9	28.9		188.2		149.0
Queue Delay	0.0	0.0			0.0		0.0	0.0		0.0		0.0
Total Delay (s/veh)	195.7	19.0			46.5		37.9	28.9		188.2		149.0
LOS	F	B			D		D	C		F		F
Approach Delay (s/veh)		101.8			46.5			31.9				159.1
Approach LOS		F			D			C				F

Intersection Summary

Area Type: Other  
 Cycle Length: 90.5  
 Actuated Cycle Length: 86.2  
 Natural Cycle: 110  
 Control Type: Actuated-Uncoordinated  
 Maximum v/c Ratio: 1.31  
 Intersection Signal Delay (s/veh): 89.3  
 Intersection LOS: F  
 Intersection Capacity Utilization 116.9%  
 ICU Level of Service H  
 Analysis Period (min) 15

Splits and Phases: 10: US 101 NB Off Ramp/Lakewood Drive & Old Redwood Highway

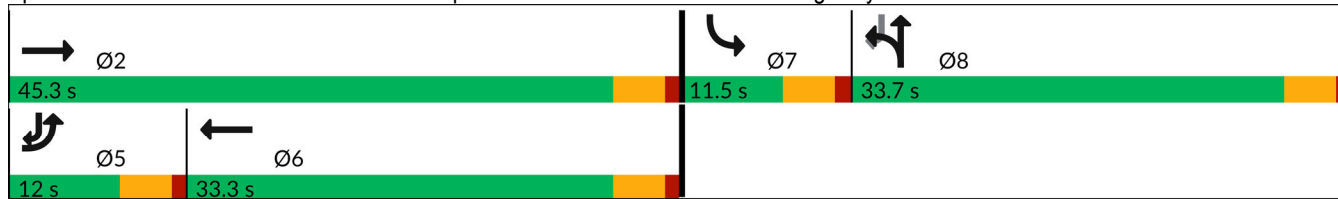

Lanes, Volumes, Timings  
 11: Old Redwood Highway & US 101 NB On Ramp

General Plan 2040 Project Altern. C Conditions  
 Timing Plan: Saturday Midday Peak

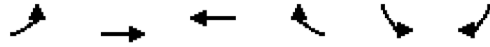

Lane Group	EBL	EBT	WBT	WBR	SBL	SBR
Lane Configurations						
Traffic Volume (vph)	112	801	1698	279	0	0
Future Volume (vph)	112	801	1698	279	0	0
Ideal Flow (vphp)	1900	1900	1900	1900	1900	1900
Storage Length (ft)	245			0	0	0
Storage Lanes	1			0	0	0
Taper Length (ft)	50				25	
Lane Util. Factor	1.00	0.95	0.95	0.95	1.00	1.00
Ped Bike Factor						
Frt			0.979			
Flt Protected	0.950					
Satd. Flow (prot)	1770	3539	3465	0	0	0
Flt Permitted	0.950					
Satd. Flow (perm)	1770	3539	3465	0	0	0
Link Speed (mph)		35	35		30	
Link Distance (ft)		531	226		299	
Travel Time (s)		10.3	4.4		6.8	
Confl. Peds. (#/hr)	8			8		
Confl. Bikes (#/hr)				4		
Peak Hour Factor	0.96	0.96	0.92	0.92	0.25	0.25
Adj. Flow (vph)	117	834	1846	303	0	0
Shared Lane Traffic (%)						
Lane Group Flow (vph)	117	834	2149	0	0	0
Enter Blocked Intersection	No	No	No	No	No	No
Lane Alignment	Left	Left	Left	Right	Left	Right
Median Width(ft)		12	12		0	
Link Offset(ft)		0	0		0	
Crosswalk Width(ft)		16	16		16	
Two way Left Turn Lane						
Headway Factor	1.00	1.00	1.00	1.00	1.00	1.00
Turning Speed (mph)	15			9	15	9
Sign Control		Free	Free		Free	

Intersection Summary

Area Type:	Other
Control Type:	Unsignalized
Intersection Capacity Utilization	89.5%
Analysis Period (min)	15
	ICU Level of Service E

Lanes, Volumes, Timings

General Plan 2040 Project Altern. C Conditions

12: US 101 SB On Ramp/US 101 SB Off Ramp & Old Redwood Highway Timing Plan: Saturday Midday Peak



Lane Group	EBL	EBT	EBR	WBL	WBT	WBR	NBL	NBT	NBR	SBL	SBT	SBR
Lane Configurations		↑↑	↗	↖	↑↑					↖	↕	
Traffic Volume (vph)	0	713	543	632	1060	0	0	0	0	213	1	112
Future Volume (vph)	0	713	543	632	1060	0	0	0	0	213	1	112
Ideal Flow (vphpl)	1900	1900	1900	1900	1900	1900	1900	1900	1900	1900	1900	1900
Storage Length (ft)	0		0	250		0	0		0	420		0
Storage Lanes	0		1	0		0	0		0	1		0
Taper Length (ft)	25			165			25			75		
Lane Util. Factor	1.00	0.95	1.00	1.00	0.95	1.00	1.00	1.00	1.00	0.95	0.95	1.00
Ped Bike Factor			0.98	1.00								
Frt			0.850								0.892	
Flt Protected				0.950						0.950	0.987	
Satd. Flow (prot)	0	3539	1583	1770	3539	0	0	0	0	1681	1558	0
Flt Permitted				0.950						0.950	0.987	
Satd. Flow (perm)	0	3539	1553	1769	3539	0	0	0	0	1681	1558	0
Right Turn on Red			Yes			Yes			Yes			Yes
Satd. Flow (RTOR)			409								141	
Link Speed (mph)		35			35			30			30	
Link Distance (ft)		423			531			621			831	
Travel Time (s)		8.2			10.3			14.1			18.9	
Confl. Peds. (#/hr)	11		2	2		11						
Confl. Bikes (#/hr)			10			2						
Peak Hour Factor	0.97	0.97	0.97	0.96	0.96	0.96	0.25	0.25	0.25	0.72	0.72	0.72
Adj. Flow (vph)	0	735	560	658	1104	0	0	0	0	296	1	156
Shared Lane Traffic (%)										20%		
Lane Group Flow (vph)	0	735	560	658	1104	0	0	0	0	237	216	0
Enter Blocked Intersection	No	No	No	No	No	No	No	No	No	No	No	No
Lane Alignment	Left	Left	Right	Left	Left	Right	Left	Left	Right	Left	Left	Right
Median Width(ft)		24			24			12			12	
Link Offset(ft)		0			0			0			0	
Crosswalk Width(ft)		16			16			16			16	
Two way Left Turn Lane												
Headway Factor	1.00	1.00	1.00	1.00	1.00	1.00	1.00	1.00	1.00	1.00	1.00	1.00
Turning Speed (mph)	15		9	15		9	15		9	15		9
Number of Detectors		2	1	1	2					1	2	
Detector Template		Thru	Right	Left	Thru					Left	Thru	
Leading Detector (ft)		100	20	20	100					20	100	
Trailing Detector (ft)		0	0	0	0					0	0	
Detector 1 Position(ft)		0	0	0	0					0	0	
Detector 1 Size(ft)		6	20	20	6					20	6	
Detector 1 Type		Cl+Ex	Cl+Ex	Cl+Ex	Cl+Ex					Cl+Ex	Cl+Ex	
Detector 1 Channel												
Detector 1 Extend (s)		0.0	0.0	0.0	0.0					0.0	0.0	
Detector 1 Queue (s)		0.0	0.0	0.0	0.0					0.0	0.0	
Detector 1 Delay (s)		0.0	0.0	0.0	0.0					0.0	0.0	
Detector 2 Position(ft)		94			94							94
Detector 2 Size(ft)		6			6							6
Detector 2 Type		Cl+Ex			Cl+Ex							Cl+Ex
Detector 2 Channel												
Detector 2 Extend (s)		0.0			0.0							0.0

Lanes, Volumes, Timings

General Plan 2040 Project Altern. C Conditions

12: US 101 SB On Ramp/US 101 SB Off Ramp & Old Redwood Highway Timing Plan: Saturday Midday Peak



Lane Group	EBL	EBT	EBR	WBL	WBT	WBR	NBL	NBT	NBR	SBL	SBT	SBR
Turn Type		NA	Perm	Prot	NA					Perm	NA	
Protected Phases		6		5	2						8	
Permitted Phases			6							8		
Detector Phase		6	6	5	2					8	8	
Switch Phase												
Minimum Initial (s)		10.0	10.0	7.0	10.0					10.0	10.0	
Minimum Split (s)		32.1	32.1	11.5	38.1					14.7	14.7	
Total Split (s)		32.3	32.3	23.0	55.3					14.7	14.7	
Total Split (%)		46.1%	46.1%	32.9%	79.0%					21.0%	21.0%	
Maximum Green (s)		27.8	27.8	18.5	50.8					10.2	10.2	
Yellow Time (s)		3.5	3.5	3.5	3.5					3.5	3.5	
All-Red Time (s)		1.0	1.0	1.0	1.0					1.0	1.0	
Lost Time Adjust (s)		0.0	0.0	0.0	0.0					0.0	0.0	
Total Lost Time (s)		4.5	4.5	4.5	4.5					4.5	4.5	
Lead/Lag		Lag	Lag	Lead								
Lead-Lag Optimize?		Yes	Yes	Yes								
Vehicle Extension (s)		3.0	3.0	3.0	3.0					3.0	3.0	
Recall Mode		Max	Max	None	Max					None	None	
Walk Time (s)		7.0	7.0		7.0							
Flash Don't Walk (s)		20.0	20.0		25.0							
Pedestrian Calls (#/hr)		0	0		0							
Act Effct Green (s)		27.8	27.8	18.5	50.8					10.2	10.2	
Actuated g/C Ratio		0.40	0.40	0.26	0.73					0.15	0.15	
v/c Ratio		0.52	0.65	1.41	0.43					0.97	0.62	
Control Delay (s/veh)		17.7	8.7	222.1	4.4					84.8	19.8	
Queue Delay		0.0	0.0	0.0	0.0					0.0	0.0	
Total Delay (s/veh)		17.7	8.7	222.1	4.4					84.8	19.8	
LOS		B	A	F	A					F	B	
Approach Delay (s/veh)		13.8			85.7						53.8	
Approach LOS		B			F						D	

Intersection Summary

Area Type: Other  
 Cycle Length: 70  
 Actuated Cycle Length: 70  
 Natural Cycle: 90  
 Control Type: Actuated-Uncoordinated  
 Maximum v/c Ratio: 1.41  
 Intersection Signal Delay (s/veh): 55.1  
 Intersection LOS: E  
 Intersection Capacity Utilization 89.5%  
 ICU Level of Service E  
 Analysis Period (min) 15

Splits and Phases: 12: US 101 SB On Ramp/US 101 SB Off Ramp & Old Redwood Highway

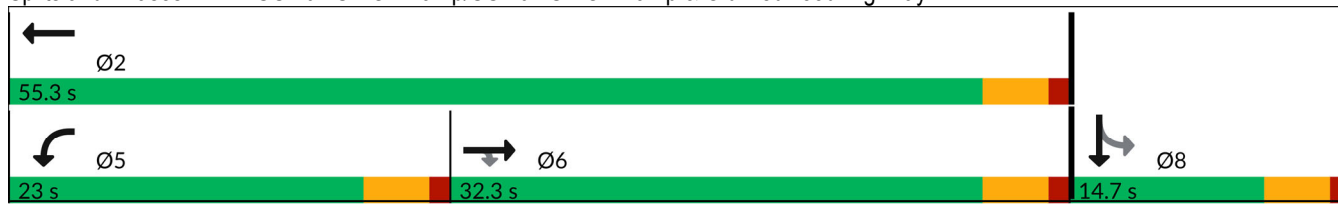

Appendix N – Napa County Winery Trip Generation Worksheet





A Tradition of Stewardship  
A Commitment to Service

# WINERY TRIP GENERATION WORKSHEET

Planning, Building & Environmental Services

1195 Third Street, Suite 210

Napa, CA 94559-3082

(707) 253-4417

## PROJECT DESCRIPTION

<b>Winery Name:</b> _____	<b>Date Prepared:</b> _____
---------------------------	-----------------------------

Existing Entitled Winery		Harvest	Non-Harvest
Number of Full Time Employees*	Weekday	_____	_____
	Weekend	_____	_____
Number of Part Time Employees*	Weekday	_____	_____
	Weekend	_____	_____
Maximum Daily Visitation	Weekday	_____	_____
	Weekend	_____	_____
Annual Gallons of Production		_____	_____
Annual Tons of Grape Haul		_____	N/A
Number of Visitors at the Largest Event that occurs two or more times per month, on average	Weekday	_____	_____
	Weekend	_____	_____

Proposed Winery		Harvest	Non-Harvest
Number of Full Time Employees*	Weekday	_____	_____
	Weekend	_____	_____
Number of Part Time Employees*	Weekday	_____	_____
	Weekend	_____	_____
Maximum Daily Visitation	Weekday	_____	_____
	Weekend	_____	_____
Annual Gallons of Production		_____	_____
Annual Tons of Grape Haul		_____	N/A
Number of Visitors at the Largest Event that occurs two or more times per month, on average	Weekday	_____	_____
	Weekend	_____	_____

\*Number of full time and part time employees should represent the max number of employees that will be working on any given day (including all vendors and contractors employed for the largest event that occurs two or more times per month on average).

# TRIP GENERATION

Existing Winery				Harvest	Non-Harvest
<u>Maximum Daily Weekday Traffic (Friday)</u>					
	<u>Harvest</u>	<u>Non-Harvest</u>			
FT Employees			3.05 one way trips/employee	FT Employee Daily Trips	
PT Employees			1.9 one way trips/employee	PT Employee Daily Trips	
Max Visitors			2.6 visitors/vehicle for 2 one way trips	Max Visitor Daily Trips	
Max Event			2.6 visitors/vehicle for 2 one way trips	Max Event Daily Trips	
Gallons of Production			0.000018 truck trips	Production Daily Trips	
Tons of Grape Haul#			0.013889 truck trips	Grape Haul Daily Trips	
			<b>Total Weekday Daily Trips</b>		
			<b>Total Weekday Peak Hour Trips*</b>		
<u>Maximum Daily Weekend Traffic (Saturday)</u>					
	<u>Harvest</u>	<u>Non-Harvest</u>			
FT Employees			3.05 one way trips/employee	FT Employee Daily Trips	
PT Employees			1.9 one way trips/employee	PT Employee Daily Trips	
Max Visitors			2.8 visitors/vehicle for 2 one way trips	Max Visitor Daily Trips	
Max Event			2.8 visitors/vehicle for 2 one way trips	Max Event Daily Trips	
Gallons of Production			0.000018 truck trips	Production Daily Trips	
Tons of Grape Haul#			0.013889 truck trips	Grape Haul Daily Trips	
			<b>Total Weekend Daily Trips</b>		
			<b>Total Weekend Peak Hour Trips*</b>		
<u>Maximum Annual Traffic</u>					
			<b>Total Annual Trips**</b>		

Proposed Winery				Harvest	Non-Harvest
<u>Maximum Daily Weekday Traffic (Friday)</u>					
	<u>Harvest</u>	<u>Non-Harvest</u>			
FT Employees			3.05 one way trips/employee	FT Employee Daily Trips	
PT Employees			1.9 one way trips/employee	PT Employee Daily Trips	
Max Visitors			2.6 visitors/vehicle for 2 one way trips	Max Visitor Daily Trips	
Max Event			2.6 visitors/vehicle for 2 one way trips	Max Event Daily Trips	
Gallons of Production			0.000018 truck trips	Production Daily Trips	
Tons of Grape Haul#			0.013889 truck trips	Grape Haul Daily Trips	
			<b>Total Weekday Daily Trips</b>		
			<b>Total Weekday Peak Hour Trips*</b>		
<u>Maximum Daily Weekend Traffic (Saturday)</u>					
	<u>Harvest</u>	<u>Non-Harvest</u>			
FT Employees			3.05 one way trips/employee	FT Employee Daily Trips	
PT Employees			1.9 one way trips/employee	PT Employee Daily Trips	
Max Visitors			2.8 visitors/vehicle for 2 one way trips	Max Visitor Daily Trips	
Max Event			2.8 visitors/vehicle for 2 one way trips	Max Event Daily Trips	
Gallons of Production			0.000018 truck trips	Production Daily Trips	
Tons of Grape Haul#			0.013889 truck trips	Grape Haul Daily Trips	
			<b>Total Weekend Daily Trips</b>		
			<b>Total Weekend Peak Hour Trips*</b>		
<u>Maximum Annual Traffic</u>					
			<b>Total Annual Trips**</b>		

Net New Trips		Harvest	Non-Harvest
<u>Maximum Weekday Traffic (Friday)</u>			
If total net new daily trips is greater than 40, a TIS is required		<b>Net New Weekday Daily Trips</b>	
		<b>Net New Weekday Peak Hour Trips*</b>	
<u>Maximum Weekend Traffic (Saturday)</u>			
If total net new daily trips is greater than 40, a TIS is required		<b>Net New Weekend Daily Trips</b>	
		<b>Net New Weekend Peak Hour Trips*</b>	
<u>Maximum Annual Traffic</u>			
		<b>Net New Annual Trips**</b>	

#Trips associated with Grape Haul represent harvest season only.

\*Weekday peak hour trips are calculated as 38% of daily trips associated with visitors and production plus one trip per employee. Weekend peak hour trips are calculated as 57% of daily trips associated with visitors and production plus one trip per employee.

\*\*Annual trips represent a conservative calculation that assumes 11 weeks of harvest, all weekdays are Fridays, all weekends are Saturdays, and assumes that the largest event that occurs two or more times per month on average occurs every day.

Appendix O – Vehicle Miles Travelled Results

**SCTA Model Travel Demand Model VMT Outputs for Alternative A**

<b>TAZ</b>	<b>Total Employment</b>	<b>ALLHB VMT - Attraction<sup>1</sup></b>	<b>VMT/Job</b>
<b>#88 – No Project</b>	0	0	0
<b>#88 – With Project</b>	537	5477.89	10.20
<b>Sonoma County Threshold</b>			10.53

**SCTA Model Travel Demand Model VMT Outputs for Alternative B**

<b>TAZ</b>	<b>Total Employment</b>	<b>ALLHB VMT – Attraction<sup>1</sup></b>	<b>VMT/Job</b>
<b>#88 – No Project</b>	0	0	0
<b>#88 – With Project</b>	295	3025.44	10.26
<b>Sonoma County Threshold</b>			10.53

**SCTA Model Travel Demand Model VMT Outputs for Alternative C**

<b>TAZ</b>	<b>Total Employment</b>	<b>ALLHB VMT – Attraction<sup>1</sup></b>	<b>VMT/Job</b>
<b>#88 – No Project</b>	0	0	0
<b>#88 – With Project</b>	295	2470.25	10.25
<b>Sonoma County Threshold</b>			10.53

---

<sup>1</sup> Total Home-based VMT (Attraction)